

**THE PARAMEDIAN RETICULAR
NUCLEUS: A SITE OF INHIBITORY INTERACTION BETWEEN
PROJECTIONS FROM FASTIGIAL NUCLEUS AND CAROTID
SINUS NERVE ACTING ON BLOOD PRESSURE**

BY MITSUHIKO MIURA AND DONALD J. REIS

*From the Department of Neurology, Cornell University
Medical College, New York, New York 10021*

(Received 20 January 1971)

SUMMARY

1. The interaction between the pressor response to electrical stimulation of the fastigial nucleus (FN), the fastigial pressor response (FPR), and the depressor response to electrical stimulation of the carotid sinus nerve (CSN) was examined in paralysed anaesthetized cats.

2. Blood pressure responses evoked by electrical stimulation of the FN and the CSN were mutually inhibitory and summed algebraically.

3. The FPR was augmented after denervation of buffer nerves. Lesions of the FN did not alter the depressor response to stimulation of the CSN.

4. Bilateral electrolytic lesions of the paramedian reticular nucleus abolished both the FPR and the CSN depressor response without altering base line pressure.

5. With micro-electrode recording neurones were discovered within the paramedian reticular nucleus which responded to electrical stimulation of the FN or the CSN. These neurones were polysynaptically excited by stimulation of either the FN or the CSN but rarely from both, and could be further subdivided into cells responding with either a single spike or a burst discharge.

6. The interaction between the FN and the CSN projections to the paramedian reticular nucleus was examined by conditioning-test studies. Eleven per cent of FN- and CSN-units were inhibited by conditioning stimulation of the heteronymous input. The interaction was exclusively inhibitory and observed only in units with latencies > 4 msec and having burst responses. The latency for inhibition was > 20 msec, peaked around 100 msec and lasted up to 300 msec.

7. We conclude that the FRP is buffered by baroreceptors and that there is a mutually inhibitory interaction between projections from the

FN and the CSN acting on sympathetic vasomotor neurones. The paramedian reticular nucleus appears to be an important site for the interaction.

8. The findings support the view that interneurones mediating pressor and depressor responses are intermixed within the medial reticular formation of the medulla.

INTRODUCTION

Electrical stimulation restricted to the rostral ventral medial portion of the fastigial nucleus (FN) of cat can evoke a powerful elevation of the systemic blood pressure (Miura, Kawamura & Reis, 1969; Miura & Reis, 1969*a*, 1970; Achari & Downman, 1969, 1970). We have called this response the fastigial pressor response (FPR). The FPR is relayed by the fastigiobulbar tract to the paramedian reticular nucleus (Miura & Reis, 1969*a*, 1970), a subnucleus of the medullary reticular formation lying at the level of the obex (Brodal, 1957). This nucleus appears to relay the blood pressure response to spinal preganglionic sympathetic vasomotor neurones (Achari & Downman, 1970). Since the paramedian reticular nucleus also receives mono- and poly-synaptic projections (Miura & Reis, 1968, 1969*b*; Homma, Miura & Reis, 1970), primarily baroreceptor in function (M. Miura & D. J. Reis, unpublished data) from the carotid sinus nerve (CSN), it seems likely that this nucleus may be an important site for the integration of cerebellar and baroreceptor reflexes acting on the blood pressure (Moruzzi, 1940; Reis & Cuenod, 1965; Hoffer, Ratcheson & Snider, 1966). This view is further substantiated by the fact that the only other site of termination of baroreceptor fibres, the middle third of the nucleus of the solitary tract (Humphrey, 1967; Miura & Reis, 1968, 1969*b*; Seller & Illert, 1969; Biscoe & Sampson, 1970*a, b*) does not receive a projection from the FN (Thomas, Kaufman, Sprague & Chambers, 1956).

In the present study we have sought to establish the nature of the interaction on the blood pressure between the FPR and the carotid sinus baroreceptor reflexes, to ascertain whether such interaction takes place in the paramedian reticular nucleus, and by the use of micro-electrode methods to determine at the neuronal level the nature of the interaction. It will be demonstrated that the FPR and the carotid sinus baroreceptor reflexes share a mutually inhibitory interaction on the systemic blood pressure and that the paramedian reticular nucleus serves as at least one site for this interaction. A preliminary communication of some of these data has been presented elsewhere (Miura *et al.* 1969).

METHODS

A Methods

Adult cats were anaesthetized with alpha chloralose (35–55 mg/kg *i.v.*) or decerebrated at the midcollicular level under ether anaesthesia. In most experiments the animals were paralysed with gallamine triethiodide (5 mg/kg *i.v.*) and then artificially ventilated. This procedure eliminated body movements which interfered with micro-electrode recording. A polyethylene catheter was inserted in the femoral artery and the trachea was cannulated. The arterial blood pressure recorded from the femoral catheter through a pressure transducer (Statham, P 230b), the heart rate computed from the blood pressure pulse by a cardi tachometer (Beckman, Type 9857) and end-expired CO₂ maintained at 2–3 %, recorded by an infra-red gas analyser (Beckman, LB-1) were displayed on channels of a polygraph (Beckman, Dynograph recorder, Type 504 A). The rectal temperature was maintained at 37° C by a thermostatically regulated infra-red lamp. The animal was then placed in a stereotaxic frame with the head flexed to 45°. The left CSN was approached from behind through an incision descending caudally and laterally from the level of the auditory bulla for about 5 cm. The sternocleidomastoid and digastric muscles overlying the sinus region were then transected and reflected, a large overlying lymph node was removed and the hypoglossal nerve transected. The CSN could then be identified and freed by gentle dissection from the underlying tissue for subsequent placement on an electrode. The nerve was then crushed distal to the electrode. In some experiments all four 'buffer nerves' (both carotid sinus and aortic nerves) were identified through the mid line ventral neck incision made at the time the tracheal cannula was inserted. A silk suture was loosely placed around each nerve and brought out through the ventral neck incision for subsequent denervation by briskly tugging the ligature. The carotid sinus was stimulated 'naturally' in some experiments by tugging on a ligature placed around the common carotid artery proximal to the sinus.

The FPR was elicited by electrical stimulation of the ventromedial quadrant of the rostral FN (Miura & Reis, 1970) through a monopolar Teflon coated steel wire electrode (diameter 0.006 in.) bared at the tip for 0.3 mm and carried in a no. 28 stainless-steel hypodermic tubing. The floor of the fourth ventricle was then exposed by removing the caudal vermis of the cerebellum and was covered with 4 % (w/v) agar saline solution to reduce pulsatile movement of the brain stem and also to prevent evaporative cooling of the surface of the brain. The electrode was inserted directly through the cerebellar cortex which was exposed by an occipital craniotomy and lowered to a site from which a maximal pressor response was elicited. The anodal electrode was a copper clip attached to a scalp muscle. The CSN was electrically stimulated by a bipolar platinum wire electrode with an interelectrode distance of 2 mm.

Electrical stimuli were square-wave pulses of 0.1 msec duration delivered to the animal from a pulse generator (Devices, Digitimer) through an isolation unit (Devices, MK IV). The stimulus current was continuously monitored and measured by passing it across a 10 Ω resistor, was amplified by a preamplifier (Tektronix 122) and displayed on an oscilloscope (Tektronix 360).

Lesions were produced by passing a current of 5 mA for 30 sec from a constant d.c. source through electrodes similar to those used for stimulation but with tips exposed for 1 mm. Lesions were usually placed when the animals were paralysed by gallamine triethiodide (5 mg/kg *i.v.*) and artificially ventilated with end-expired CO₂, maintained at 2–3 %.

Recording electrodes were glass micropipettes filled with 2 M-NaCl and fast green dye for marking (Thomas & Wilson, 1965) and mounted in a hydraulic micro-drive

(Kopf). The tips were 1–4 μ in diameter. Evoked unit potentials were amplified through an electrometer preamplifier (Bioelectric, PF 2) and an operational amplifier (Philbrick Nexus, P 85AU) and simultaneously displayed on an oscilloscope (Tektronix 565) and fed into a channel of a tape recorder (Ampex SP-300) for subsequent analysis.

B *Methods of unit analysis*

The region of the medulla oblongata explored with micro-electrodes lay within the confines of an area extending 2 mm rostral to the obex, between 0.3 and 1.3 mm lateral to the mid line, and between 1.5 and 5 mm from the ependymal surface of the fourth ventricle. The paramedian reticular nucleus lies within this region (Homma, Miura & Reis, 1970). To confirm that unit recording was confined to this region several units in each experiment were marked iontophoretically with fast green dye (Thomas & Wilson, 1965) and subsequently identified histologically. The electrode was advanced in 10 μ steps. At each electrode position, evoked unit potentials were sought by alternating stimulation of the FN and the CSN with single or multiple (two or three) shocks delivered at 500 c/s at an intensity 3–5 times the threshold of the appropriate blood pressure responses. To exclude the possibility that unit potentials evoked by FN stimulation (FN-units) were excited by spread of the stimulus current to regions outside of the fastigial pressor area, when a FN-unit was identified, the stimulating electrode was advanced or withdrawn out of the fastigial pressor area to see if the unit activity stopped. If it did, it was classified as a FN-unit and the stimulating electrode was then repositioned at the active pressor site. Evoked unit activity was established as originating in cell bodies and not in axons by accepted criteria (Salmoiraghi & Burns, 1960; Terzuolo & Araki, 1961).

When a unit was identified as being evoked by stimulation of the FN or the CSN, a conditioning-test series was carried out to determine if there was any interaction between the two inputs. Single or multiple (two or three) trains of 500 c/s were used for both conditioning and test stimulation. The stimulus intensities were selected to be 3–5 times the threshold of blood pressure responses for the conditioning stimulation and 3–5 times the threshold of evoked unit activity for the test stimulation.

If the evoked response consisted of a single spike, the criteria of interaction was whether the conditioning stimulation changed the firing probability or number of positive responses for a series of ten trials. When the test response was a burst, the number of spikes from ten trials was averaged.

Spike activity was fed either on-line from the amplification stage or off-line from a taped record into an electronic counter (Hewlett Packard, Type 52231) and printer. Shock artifacts and small background spikes were cancelled by use of a FET analogue gate (Siliconix, 2N-3970). The analogue gate system was designed by Mr Fumio Kawamura (Heiwa Electronic Corporation, Osaka, Japan) and is schematically presented in Fig. 1.

C *Histological confirmation*

At the completion of each experiment the animal was perfused with 10% (v/v) formaldehyde in saline solution and the brain was fixed, frozen and sectioned every 75 μ . The extent of lesions and the location of dye spots deposited near units of interest were identified before and after staining with the Nissl method for cells or the Weil method for myelin.

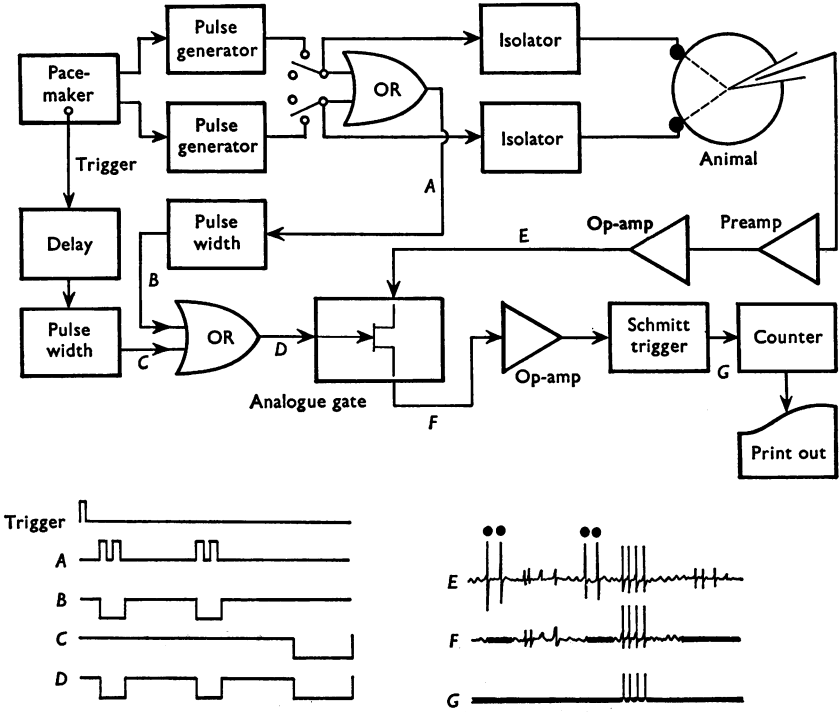

Fig. 1. Circuit diagram of stimulation and recording system (upper portion) and simulated recordings at different points in the network (lower portion). Trigger pulse from a pacemaker (Devices, Digitimer) evokes the first and the second double shock stimuli repetitively driven (A) from a pulse generator (Devices). Pulses relayed through a stimulus isolation unit are directed to the animal to stimulate the carotid sinus nerve or the fastigial nucleus. Evoked activity of brain stem neurones is shown (E) as a quartet of spikes responding to the second but not the first of a pair of double shock stimuli. The stimulus pulses are also led by an electronic switch (OR) to a pulse generator (Tektronix, Type 161) which converts the double pulse trains to a single pulse of the same duration (B). The trigger pulse is also delivered to a delay circuit (Tektronix, Type 161) and its duration variably adjusted through a pulse generator (Tektronix, Type 161). The combined signals from the stimulator and the delay circuit (D) are led through an analogue gate which has also received the amplified signal from the brain (E). Input D effectively cancels out the shock (stimulus) artifact and background noises (F). After amplification by an operational amplifier the signal is led through a Schmitt trigger (Tektronix, Type 161) for rectification (G). The 'artifact-free' signal can then be fed into an electronic counter for on-line or off-line analysis.

RESULTS

*A Interaction between the blood pressure responses elicited by electrical stimulation of the FN and the CSN**(i) Phasic interaction*

When a pressor response evoked by electrical stimulation of the FN is paired with a depressor response of approximately equal magnitude by electrical stimulation of the CSN, the antagonistic effects on the blood pressure are cancelled (Fig. 2). Conversely, cancellation of the FPR can

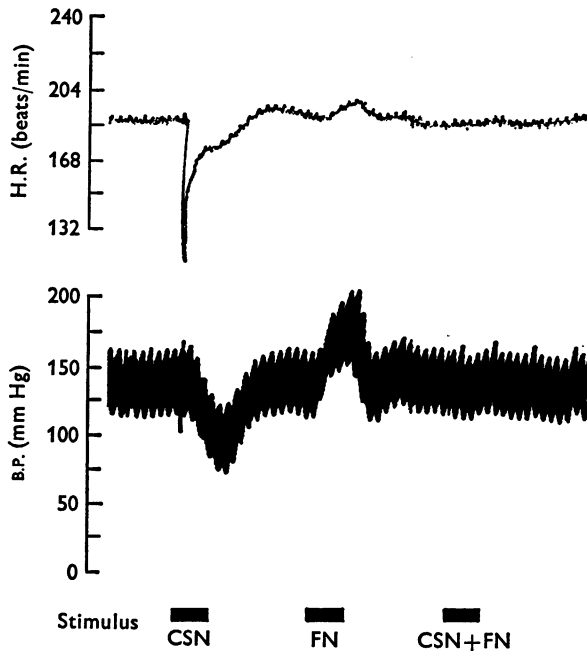

Fig. 2. Effect of electrical stimulation of the fastigial nucleus (FN) on blood pressure and heart rate responses to electrical stimulation of the carotid sinus nerve (CSN) in the anaesthetized paralysed cat. Upper trace, heart rate (H.R.) in beats per minute. Middle trace, arterial blood pressure (B.P.) in mm Hg. The FN and the CSN stimuli were 12 sec pulse trains (50 c/s and 0.1 msec pulse duration). The intensity for the FN stimulus was 0.1 mA (2 times the threshold for a pressor response) and for the CSN 0.4 mA (8 times the threshold for a depressor response). Note also the interaction on the heart rate.

also be produced by graded natural stimulation of the carotid sinus. These observations suggest (a) that there is an interaction between the projections from the FN and the CSN which act upon blood pressure, (b) that the interaction is mutually inhibitory, and (c) that the responses sum algebraically.

Further evidence for the algebraic relationship between these two opposing systems can be demonstrated by examining the effects on the blood pressure of stimulating the CSN at a constant intensity while varying the intensity of the stimulation of the FN. A typical experiment is shown in Fig. 3. It is seen that the CSN stimulus reduces the FPR by a fixed amount over a wide range of evoked changes in blood pressure. In a similar manner stimulation of the FN with a constant intensity reduces by a constant amount the amplitude of the depressor responses evoked electrically from the CSN by different stimulus intensities.

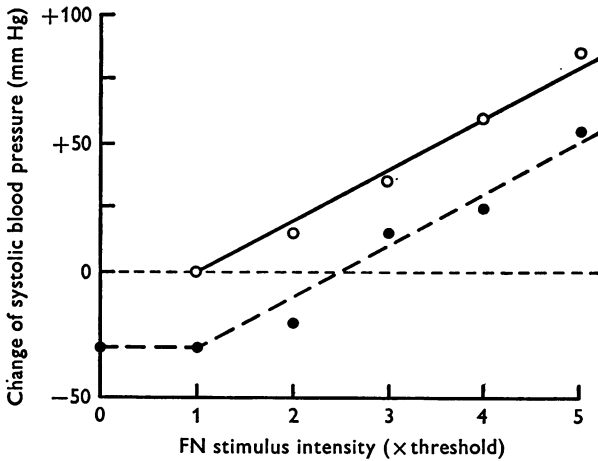

Fig. 3. Effect of increasing the intensity of the FN stimulus on the depressor responses to electrical stimulation of the CSN at constant intensity. Open circles represent control fastigial pressor responses; filled circles blood pressure changes evoked by paired stimulation of the FN and CSN. Solid circle on ordinate represents the control carotid sinus depressor response. Both FN and CSN stimulation consisted of a 12 sec train of pulses 50 c/s, of 0.1 msec duration. The threshold for the fastigial pressor response was 0.05 mA. The CSN was stimulated at 0.4 mA (6 times the threshold).

(ii) Tonic interaction

The previous experiments indicate that the CSN can act to inhibit the FPR *phasically*. That there is also *tonic* inhibition of the FRP by baroreceptors in the carotid sinus and aortic arch can be demonstrated by sequentially denervating the four buffer nerves (i.e. both carotid sinus and aortic nerves) while eliciting the FPR with a stimulus of constant intensity. As seen in Fig. 4, despite the constant stimulus intensity the FPR is augmented after cutting each buffer nerve. Similar observations have recently been reported by Achari & Downman (1970). After all buffer nerves are sectioned the pressor response is quite altered. Not

only is it larger, but it also differs from the control responses often by having a delayed recovery from the pressor phase and a marked depressor rebound (Fig. 4).

A quantitative analysis of the effect of buffer nerve denervation on the FPR is shown in Fig. 5 in which a series of stimulus intensity/response curves are plotted after serially transecting the buffer nerves. The buffer nerve denervation not only increases the magnitude of the responses but also steepens the slope of the stimulus/response curve.

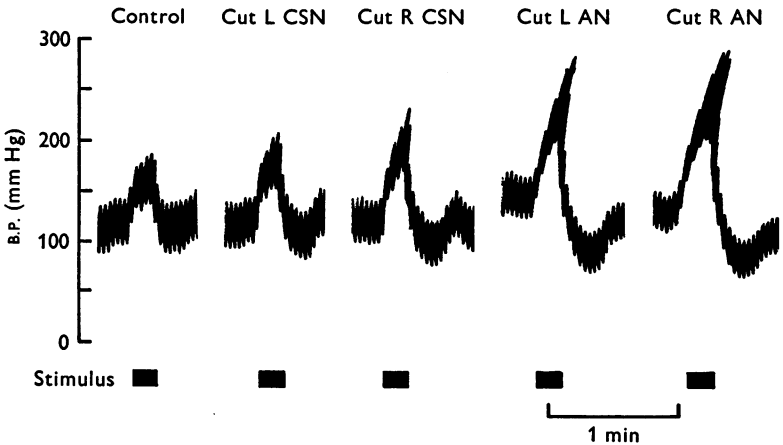

Fig. 4. Effect of sequential denervation of left (L) and right (R) carotid sinus (CSN) and aortic nerves (AN) on blood pressure (B.P.) response to electrical stimulation of the fastigial nucleus. Fastigial stimulation was constant consisting of a 12 sec train of pulses at 50 c/s, 0.1 msec pulse duration at 0.05 mA (3 times the threshold). Note progressive increase in the blood pressure response and rebound depressor response.

After sectioning the CSN bilaterally, further denervation of the aortic nerves does not produce much more change in the response particularly at higher stimulus intensities.

In contrast to the tonic inhibition exerted by baroreceptors on the FPR, bilateral destruction of the fastigial pressor region by electrolytic lesions or by aspiration does not alter the magnitude of the carotid depressor responses. Thus the FN does not appear to exert any tonic control over the carotid baroreceptor reflex, at least as elicited by electrical stimulation of the CSN.

B *Effects of lesions of the paramedian reticular nucleus on blood pressure responses evoked from the FN and the CSN*

We have previously demonstrated that bilateral lesions of the paramedian reticular nucleus abolished the FPR (Miura & Reis, 1969a).

In ten consecutive experiments, similar lesions were placed electrolytically in this nucleus. In all instances both the FPR and the depressor response to CSN stimulation were abolished. A typical experiment is seen in Fig. 6. Since the FN in cat does not project to the nucleus of the solitary tract (Thomas *et al.* 1956), the only other site of termination of the CSN afferent fibres (Miura & Reis, 1969*b*), the result suggests that

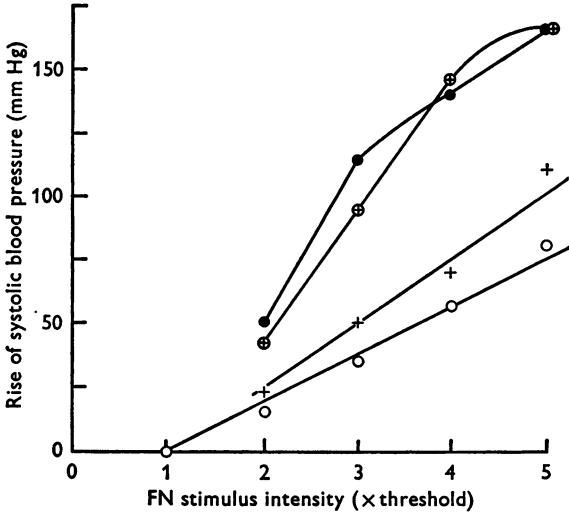

Fig. 5. Stimulus/response characteristics of the blood pressure response to electrical stimulation of the fastigial nucleus with graded stimuli (expressed as multiples of the threshold) following sequential denervation of both carotid sinus (CSN) and aortic (AN) nerves. Open circles represent control fastigial pressor responses; crosses are responses after denervation of left CSN (ipsilateral); crosses in circles are responses after denervation of right CSN (contralateral) and filled circles responses after bilateral denervation of aortic nerves.

interaction between the FPR and the carotid baroreceptor reflex resides in the paramedian reticular nucleus. No consistent changes in the base line blood pressure resulted from the lesions.

C *Micro-electrode studies of interaction between projections from the FN and the CSN within the paramedian reticular nucleus*

In order to obtain more definitive evidence that the interaction between the FPR and the carotid baroreceptor reflex takes place in the paramedian reticular nucleus, this nucleus was systematically explored with micro-electrodes in thirty-two cats. Units responding to electrical stimulation of the FN or the CSN were identified and their interaction defined by examination of the effects of conditioning stimulation on test responses. Of many hundreds of neurones encountered 170 were isolated

successfully in which activity was evoked by either CSN and/or FN stimulation and in which conditioning-test stimulus trial could be run. Spontaneously active units whose discharge pattern was modulated by stimulation of the CSN or the FN were not studied.

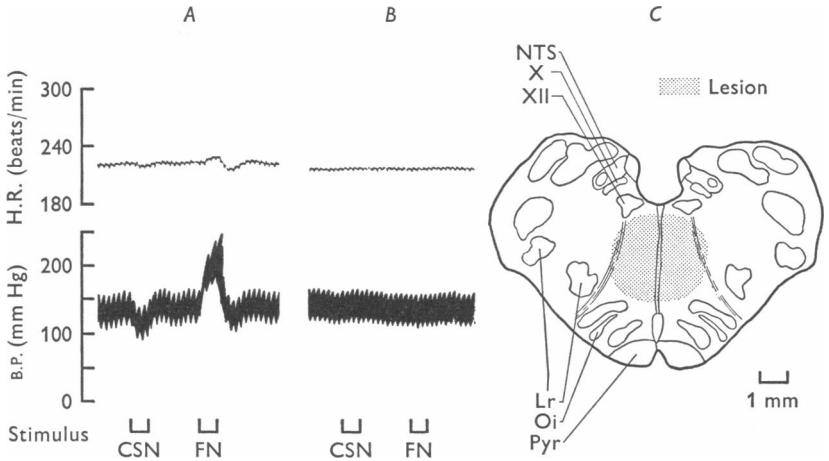

Fig. 6. Abolition of both the depressor response to stimulation of the carotid sinus nerve (CSN) and the fastigial pressor response by bilateral destruction of the paramedian reticular nucleus. *A*, control responses showing depressor response to electrical stimulation of the CSN and pressor response to electrical stimulation of the fastigial nucleus. *B*, response 30 min following electrolytic lesions placed in the paramedian reticular formation. *C*, schematic representation of extent of the lesions in this experiment outlined by shaded area. Abbreviations: NTS, nucleus of the solitary tract; X, dorsal motor nucleus of the vagus; XII, nucleus of the hypoglossal nerve; Lr, lateral reticular nucleus; Oi, inferior olivary nucleus; Pyr, pyramidal tract.

(i) *Interaction between FN and CSN stimulation on their evoked multi-unit activity*

In a preliminary study multi-unit potentials evoked by both FN and CSN stimulation were studied. As shown in Fig. 7, evoked response to CSN stimulation (Fig. 7*A*) could be abolished by a preceding stimulation of the FN (Fig. 7*B*) and conversely FN responses (Fig. 7*C*) could be depressed by a preceding CSN stimulation (Fig. 7*D*). This inhibitory interaction lasted about 150 msec. Facilitatory interactions were never seen in massed potentials.

(ii) *Classification of evoked unit responses*

An analysis of the distribution of the population of units excited by electrical stimulation of the FN or the CSN and their mutual interactions

is represented in the histogram in Fig. 8. The majority of evoked units ($n = 115$) were excited only by FN stimulation (FN units). Of these, 11 units (10%) were inhibited by preceding stimulation of the CSN. A smaller number of units ($n = 44$) were excited exclusively by CSN stimulation (CSN units). Seven units (16%) of these were inhibited by preceding stimulation of the FN. Eleven units were identified as being excited by both FN and CSN stimulation (mixed units). These were mutually inhibitory. No facilitatory interactions were ever found.

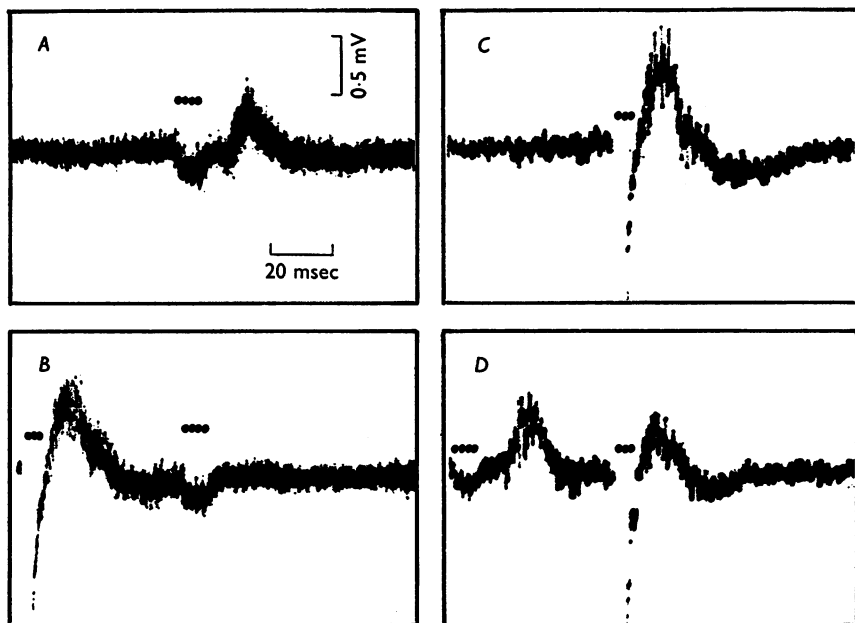

Fig. 7. Mutual inhibitory interaction between inputs from the ipsilateral carotid sinus nerve (CSN) and the fastigial nucleus (FN) in the paramedian reticular nucleus. *A*, control (test) evoked response to electrical stimulation of the CSN (four shocks, 0.1 msec pulse duration, 500 c/s, 0.4 mA or 5 times the threshold). *B*, complete inhibition of the test CSN response by a conditioning shock to the FN (three shocks, 0.1 msec pulse duration, 500 c/s, 0.2 mA or 3 times the threshold). *C*, control (test) evoked response to electrical stimulation of the FN. *D*, partial inhibition of the test FN response by conditioning shock to the CSN. The conditioning-test interval is 55 msec.

(iii) Nature of the evoked unitary responses

Two types of evoked unit activity were observed: (a) single spike responses (Fig. 9*A*); (b) burst responses (Fig. 9*B*). The distinct identity of these two types of responses could be demonstrated by the effect of stimulus intensity on the response. With increasing intensity of the stimulus

over a fivefold range, the latency of the single shock response is shortened but no more spike discharges were seen (Fig. 9A). Burst responses, on the other hand, showed an irregular recruitment of spikes with an increase in stimulus intensity. Furthermore, with a constant stimulus intensity the number of spikes/burst and the duration of the burst varied. At 3–5 times the threshold the bursts usually consisted of 4–5 spikes with a duration of 10–20 msec.

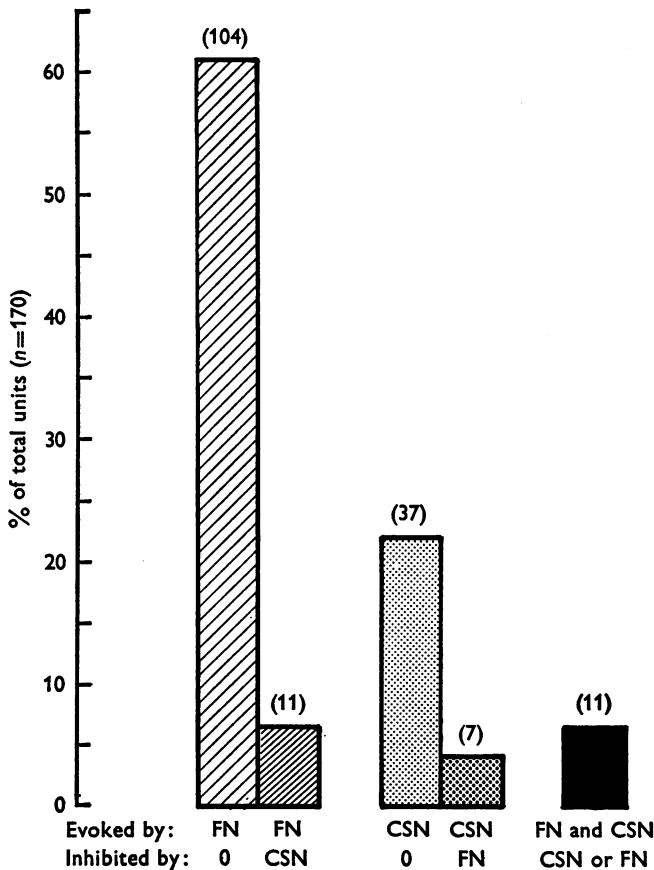

Fig. 8. Histogram showing % distribution of units in the paramedian reticular nucleus evoked by electrical stimulation of the fastigial nucleus and/or the carotid sinus nerve and response to conditioning stimuli by the heteronymous inputs. Numbers in parentheses at top of each bar represent *n*.

(iv) *Characteristics of FN- and CSN-units in the paramedian reticular nucleus*

One hundred and fifteen FN units and 44 CSN units in the paramedian reticular nucleus were studied. The distribution of these units by type of response (single spike or burst) and latency are shown in Fig. 10*A* and *B*. Only FN- and CSN units of the burst type and with longer latencies (> 4 msec) were inhibited by conditioning stimuli delivered to the

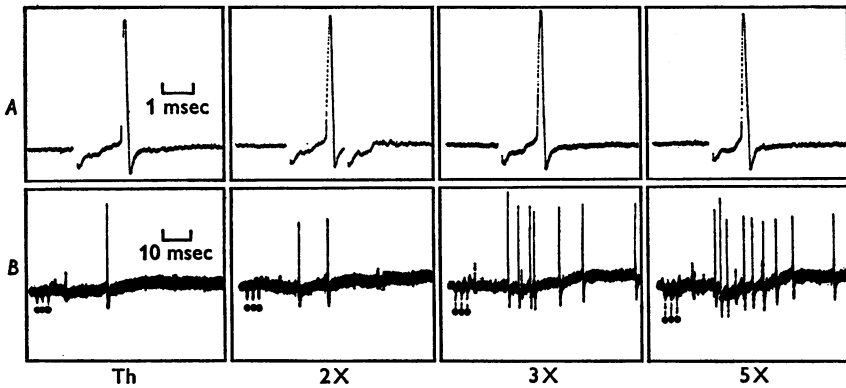

Fig. 9. Typical responses in the paramedian reticular nucleus to electrical stimulation of the fastigial nucleus. The stimulus intensity is indicated along the base line as multiples of the threshold. Row *A*: spike response. Note that latency shortens from 1.6 msec (the threshold) to 1.1 msec (5 times the threshold) without changing to a burst response. Note that at 2 \times the threshold the second shock, delivered after the first shock, failed to evoke the response. Row *B*: a typical burst response showing a spike at the threshold which expands to a prolonged burst with increasing stimulus intensity. These burst responses were evoked by three shocks delivered at 500 c/s.

opposing input (thick shaded column in Fig. 10). In general, the onset of inhibition was evident in 25–30 msec, maximal inhibition was reached at 80–120 msec, and full recovery did not occur for 250–300 msec. Rarely the whole response was abolished, but more commonly a few spikes usually remained. A typical conditioning-test study of this inhibition is shown in Fig. 11.

(v) *Characteristics of mixed units*

Eleven mixed units were studied. The majority of these showed burst responses. In most units the time course for recovery to a conditioning stimulus extended over 150 msec. Several units, however, showed a brief inhibition lasting only 5–10 msec after conditioning excitation. In these

units it is probable that the test response was inhibited by refractoriness due to the conditioning response and cannot be considered similar to the long-lasting type of active inhibition seen in most other units.

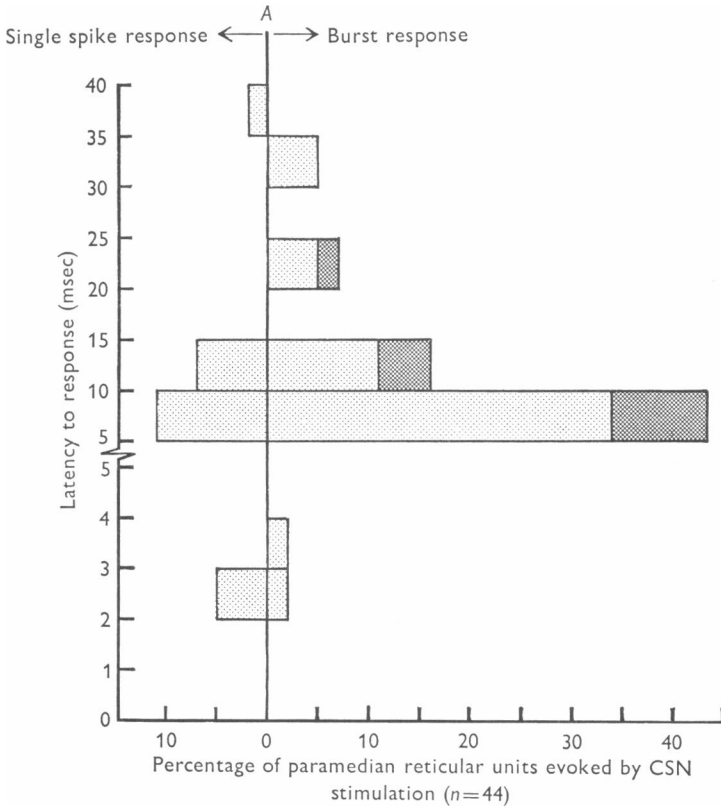

Fig. 10A. For legend see opposite page.

DISCUSSION

The present study demonstrates that the elevation of the systemic blood pressure evoked by electrical stimulation of the FN, the FPR, like most other pressor responses, is reflexly inhibited by systemic arterial baroreceptors. Conversely, a fall of blood pressure elicited by stimulation of the baroreceptor afferents in the CSN can be reduced by concurrent stimulation of the FN. These opposing blood pressure responses, therefore, interact with mutual inhibition. Within limits the interaction summates algebraically. However, the fact that even with all buffer nerves intact electrical stimulation of the FN can produce a sustained elevation of blood pressure indicates that the fastigial projection to the spinal preganglionic

sympathetic neurones can override the inhibitory feedback from baroreceptors.

Despite the simple quantitative relationship between these two neural inputs acting upon the blood pressure the peripheral mechanisms by which they act could conceivably be different. Achari & Downman (1969, 1970)

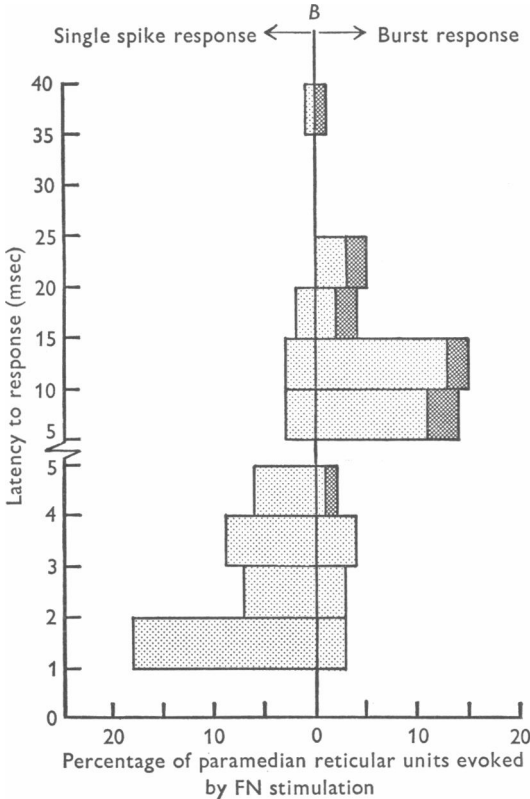

Fig. 10. Histogram showing % distribution of units evoked by electrical stimulation of the carotid sinus nerve (A) or of the fastigial nucleus (B). The units are classified into those responding with a single spike or with a burst and also subdivided by the latency to response. The shaded areas represent % of population within any given latency inhibited by conditioning stimulation of the heteronymous input. Note that inhibitory interaction between the CSN and the FN occurs only in burst responses of longer latency.

have shown that the blood pressure response is the consequence of sympathetic activation. With plethysmography they observed that the volume of paws, skinned leg, kidney and small intestine decreased. By use of the fractional dilution method for measurement of nutrient blood flow (Sapirstein, 1958) we have observed the principle reduction of blood flow

occurs in the skeletal muscle (M. Miura, F. Wooten & D. J. Reis, unpublished observations) suggesting that arterioles in muscle may be the principle site of vascular resistance. Baroreceptor activation on the other hand inhibits sympathetic vasoconstrictor activity in most vascular beds (Lindgren & Uvnäs, 1954, Löfving, 1961). However, since the effects of baroreceptor stimulation are greatest on vascular beds having the highest

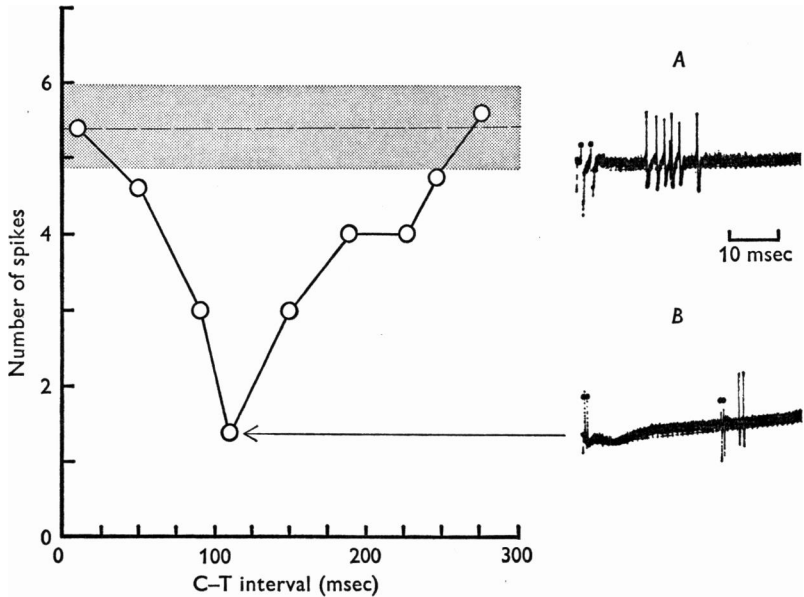

Fig. 11. A typical recovery cycle of a burst response in the paramedian reticular nucleus. The response was evoked by stimulation of the fastigial nucleus. As shown in tracing *A* in upper right-hand corner, the latency of the response is 13 msec. Conditioning stimuli to the carotid sinus nerve preceded test stimuli at varying intervals up to 300 msec. Note that the conditioning stimuli produce a progressive reduction of the number of spikes per burst between 50 and 250 msec. Tracing *B* at lower right-hand corner shows an inhibited burst recorded at a conditioning-test (C-T) interval of 110 msec. The shaded area of the diagram is the confidence limits of the control response.

sympathetic tone and the FPR appears to engage primarily arteries in skeletal muscles it is likely that the site of peripheral interaction between baroreceptors and the FPR is in that tissue.

It would seem likely that the paramedian reticular nucleus in the medulla is an important site of interaction between the FPR and the depressor response to electric stimulation of myelinated fibres in the CSN. Bilateral lesions of this nucleus, a subdivision of the medial reticular formation (Brodal & Torvik, 1954; Brodal, 1957; Brodal & Gogstad, 1957) abolishes both responses. That such lesions do not alter the base line blood

pressure indicates that the paramedian reticular nucleus is not the site of the 'vasomotor' neurones of the brain stem whose integrity is necessary for the maintenance of normal levels of blood pressure (Alexander, 1946; Chai & Wang, 1962; Chai, Share & Wang, 1963).

There are several reasons for concluding that, at least in part, the paramedian reticular nucleus serves to integrate and relay responses from the cerebellum and the carotid sinus and is not merely a conduit through which the fibres pass on their way to spinal autonomic neurones. First, there is anatomical and electrophysiological evidence that primary afferent fibres of the CSN and projections from the FN do not terminate caudal to the medulla (Thomas *et al.* 1956; Kerr, 1962; Cottle, 1964; Crill & Reis, 1968). Secondly, anatomical and electrophysiological data indicate termination of both FN and CSN fibres in this nucleus (Crill & Reis, 1968; Miura & Reis, 1968, 1969*a, b*, 1970; Homma *et al.* 1970; Ito, Udo, Mano & Kawai, 1970). Thirdly, the nucleus is the only one receiving monosynaptic inputs from both the CSN and the FN. However, the possibility that some of this interaction occurs at the level of the spinal preganglionic sympathetic neurones cannot be excluded.

Micro-electrode studies of neurones in the paramedian reticular nucleus are entirely consistent with the view that the nucleus is a site of interaction between the fastigial and the carotid sinus projections acting on the blood pressure. Admixed within the nucleus are neurones excited by electrical stimulation of both the CSN and the FN. In general, these neurones are excited polysynaptically, but from only one of the two afferent sources. The FN- and CSN neurones each exhibit a wide range of latencies to firing and each population can be subdivided on the basis of firing characteristics into the neurones responding only with a single spike and those responding with a burst of activity (burst neurones) to brief stimuli. Neurones excited by both the CSN and the FN are extremely rare. They are of interest, however, in suggesting that inputs from sources with opposing effects on blood pressure can converge upon a few common cells in the reticular formation. It is possible, however, that some fibres of the CSN arising from chemoreceptors and mediating a pressor response may project on to FN neurones which might therefore serve as common pressor' neurones in the brain stem.

The demonstration of an interaction, exclusively inhibitory, between FN- and CSN neurones in the paramedian reticular nucleus is consistent with the observation of a mutually inhibitory interaction between projections from the FN and the CSN upon the blood pressure. The neurones which are inhibited, however, consisted of a minority of each population and responded to either CSN or FN stimulation with a burst discharge. In general, they were neurones with longer latencies for firing. The latency

for inhibition was relatively long, being greater than 20 msec, peaking at 100 msec, and persisting for up to 300 msec. The latency and long course of the inhibition raises questions both as to its site of action and to its mechanism. It is possible that the inhibition results from activation of long-loop polysynaptic relays into other brain stem areas which then relay back into the paramedian reticular nucleus, as discussed elsewhere (Miura & Reis, 1969*b*). Another is that local networks of interneurons support the prolonged inhibition by either post- or presynaptic mechanisms. Characterization of these evoked responses by intracellular techniques will be necessary to decide between these alternatives.

This study also sheds new light on the problem of the organization of the cardiovascular control mechanisms in the brain stem. The paramedian reticular nucleus lies well within the so-called depressor areas of the medulla (Alexander, 1946; Brodal, 1957) and hence it is not surprising that it was discovered to serve to relay depressor responses from the carotid sinus (Miura & Reis, 1969*b*). More difficult to explain, however, was the finding that this nucleus also relayed the powerful pressor response from the FN (Miura & Reis, 1969*a*, 1970). However, detailed examination of the results of experiments by others using electrical stimulation in the brain stem indicates that stimulation within the depressor area does not always result in a fall of blood pressure and slowing of the heart rate. Rather, the punctate representation of pressor and depressor and cardio-accelerator and decelerator responses appear admixed in this area (Wang & Ranson, 1939; Monnier, 1939; Bach, 1952) including that portion of the paramedian reticular nucleus called the parahypoglossal nucleus (Calaresu & Henry, 1970). The findings of neurones in the paramedian reticular nucleus excited either by a pressor stimulus from the FN or a depressor one from the CSN is consistent with the view that the paramedian reticular nucleus is functionally heterogeneous. These two neuronal populations, moreover, indicate that the FPR cannot be explained as the result of inhibition of tonically active CSN-neurones in the paramedian reticular nucleus and the interpretation further supported by the finding that the FPR is augmented rather than diminished by interruption of buffer nerves.

Our findings suggest the engagement of separate neuronal populations by stimuli mediating pressor and depressor responses within a nucleus of evident importance in cardiovascular regulation. Our findings support a view proposed elsewhere (Reis & Cuénod, 1965) that the bulbar neurones mediating the baroreceptor reflexes are distinct from those 'vasomotor' neurones necessary for the maintenance of blood pressure, that the neurones mediating reflex depressor and pressor responses are themselves separate, receive different afferent inputs, and interact in a complex way in the reflex regulation of the blood pressure.

REFERENCES

- ACHARI, N. K. & DOWNMAN, C. B. B. (1969). Autonomic responses evoked by stimulation of fastigial nuclei in the anaesthetized cat. *J. Physiol.* **204**, 130P.
- ACHARI, N. K. & DOWNMAN, C. B. B. (1970). Autonomic effector responses to stimulation of nucleus fastigius. *J. Physiol.* **210**, 637-650.
- ALEXANDER, R. S. (1946). Tonic and reflex functions of medullary sympathetic cardiovascular centers. *J. Neurophysiol.* **9**, 205-217.
- BACH, L. M. N. (1952). Relationships between bulbar respiratory, vasomotor and somatic facilitatory and inhibitory areas. *Am. J. Physiol.* **171**, 417-435.
- BISCOE, T. J. & SAMPSON, S. R. (1970a). Field potentials evoked in the brain stem of the cat by stimulation of the carotid sinus, glossopharyngeal, aortic and superior laryngeal nerves. *J. Physiol.* **209**, 341-358.
- BISCOE, T. J. & SAMPSON, S. R. (1970b). Responses of cells in the brain stem of the cat to stimulation of the sinus, glossopharyngeal, aortic and superior laryngeal nerves. *J. Physiol.* **209**, 359-373.
- BRODAL, A. (1957). In *The Reticular Formation of the Brain Stem*, p. 87. Springfield, Illinois: Thomas.
- BRODAL, A. & GOGSTAD, A. C. (1957). Afferent connections of the paramedian reticular nucleus of the medulla oblongata in the cat. *Acta anat.* **30**, 133-151.
- BRODAL, A. & TORVIK, A. (1954). Cerebellar projection of paramedian reticular nucleus of medulla oblongata in cat. *J. Neurophysiol.* **17**, 484-495.
- CALABRESU, F. R. & HENRY, J. L. (1970). The mechanism of the cardio-acceleration elicited by electrical stimulation of the parahypoglossal area in the cat. *J. Physiol.* **210**, 107-120.
- CHAI, C. Y., SHARE, N. N. & WANG, S. C. (1963). Central control of sympathetic cardiac augmentation in the lower brain stem of the cat. *Am. J. Physiol.* **205**, 749-753.
- CHAI, C. Y. & WANG, S. C. (1962). Localization of central cardiovascular control mechanism in lower brain stem of cat. *Am. J. Physiol.* **202**, 25-30.
- COTTE, M. A. (1964). Degeneration studies of the primary afferents of IXth and Xth cranial nerves in cat. *J. comp. Neurol.* **122**, 329-345.
- CRILL, W. E. & REIS, D. J. (1968). Distribution of carotid sinus and depressor nerves in cat brain stem. *Am. J. Physiol.* **214**, 269-276.
- HOFFER, B., RATCHESON, R. & SNIDER, R. S. (1966). The effect of stimulation of the cerebellum on the circulatory system. *Fedn Proc.* **25**, 2888.
- HOMMA, S., MIURA, M. & REIS, D. J. (1970). Intracellular recording from paramedian neurones monosynaptically excited by stimulation of the carotid sinus nerve. *Brain Res.* **18**, 185-188.
- HUMPHREY, D. R. (1967). Neuronal activity in the medulla oblongata of cat evoked by stimulation of the carotid sinus nerve. In *Baroreceptors and Hypertension*, pp. 131-167, ed. KEZDI, P. Oxford: Pergamon Press.
- ITO, M., UDO, M., MANO, N. & KAWAI, N. (1970). Synaptic action of the fastigio-bulbar impulses upon neurones in the medullary reticular formation and vestibular nuclei. *Expl Brain Res.* **11**, 29-47.
- KERR, F. W. L. (1962). Facial, vagal and glossopharyngeal nerves in the cat. *Archs Neurol. Psychiat.* **6**, 264-281.
- LINDGREN, P. & UVNÄS, B. (1954). Postulated vasodilator center in the medulla oblongata. *Am. J. Physiol.* **176**, 68-76.
- LÖFVING, B. (1961). Cardiovascular adjustments induced from the rostral cingulate gyrus. *Acta physiol. scand. suppl.* **53**, 184, 1-82.
- MIURA, M., KAWAMURA, F. & REIS, D. J. (1969). A blood pressure response elicited from cerebellum and its efferent pathway in brain stem. *Fedn Proc.* **28**, 714.

- MIURA, M. & REIS, D. J. (1968). Electrophysiological evidence that carotid sinus nerve fibers terminate in the bulbar reticular formation. *Brain Res.* **9**, 394-397.
- MIURA, M. & REIS, D. J. (1969*a*). Cerebellum: a pressor response elicited from the fastigial nucleus and its efferent pathway in brainstem. *Brain Res.* **13**, 595-599.
- MIURA, M. & REIS, D. J. (1969*b*). Termination and secondary projections of carotid sinus nerve in the cat brain stem. *Am. J. Physiol.* **217**, 142-153.
- MIURA, M. & REIS, D. J. (1970). A blood pressure response from fastigial nucleus and its relay pathway in brainstem. *Am. J. Physiol.* **219**, 1330-1336.
- MONNIER, M. (1939). Les centres végétatifs bulbaires (effets de l'excitation faradique du bulbe sur la respiration, la tension artérielle, le pouls, la vessie et la pupille chez le Chat). *Archs int. Physiol.* **49**, 455-463.
- MORUZZI, G. (1940). Paleocerebellar inhibition of vasomotor and respiratory carotid sinus reflexes. *J. Neurophysiol.* **3**, 20-32.
- REIS, D. J. & CUÉNOD, M. (1965). Central neural regulation of carotid baroreceptor reflexes in the cat. *Am. J. Physiol.* **209**, 1267-1279.
- SALMOIRAGHI, G. C. & BURNS, B. D. (1960). Localization and patterns of discharge of respiratory neurones in brain stem of cat. *J. Neurophysiol.* **23**, 2-13.
- SAPIRSTEIN, A. L. (1958). Regional blood flow by fractional distribution of indicators. *Am. J. Physiol.* **193**, 161-168.
- SELLER, H. & ILLERT, M. (1969). The localization of the first synapse in the carotid sinus baroreceptor reflex pathway and its alteration of the afferent input. *Pflügers Arch. ges. Physiol.* **306**, 1-19.
- TERZUOLO, C. A. & ARAKI, T. (1961). An analysis of intra- versus extracellular potential changes associated with activity of single spinal motoneurons. *Ann. N.Y. Acad. Sci.* **94**, 547-558.
- THOMAS, D. M., KAUFMAN, R. P., SPRAGUE, J. M. & CHAMBERS, W. W. (1956). Experimental studies of the vermal cerebellar projections in the brain stem of the cat. *J. Anat.* **90**, 371-385.
- THOMAS, R. C. & WILSON, V. J. (1965). Precise localization of Renshaw cells with a new marking technique. *Nature, Lond.* **206**, 211-213.
- WANG, S. C. & RANSON, S. W. (1939). Autonomic responses to electrical stimulation of the lower brain stem. *J. comp. Neurol.* **71**, 437-455.