

## FREE-OPERANT AVOIDANCE IN THE PIGEON USING A TREADLE RESPONSE<sup>1</sup>

RICHARD F. SMITH AND FREDERICK R. KELLER

UNIVERSITY OF UTAH

A free-operant avoidance schedule was used to establish and maintain foot-treadle responding by two Homing, one White King, and two Carneaux pigeons. In the absence of responding, the interval between shocks equaled 10 sec. Each time a treadle response occurred the shock was postponed for 32 sec. Pigeons appear to learn the treadle response more quickly and use it to avoid shock more successfully than do rats bar pressing on similar schedules. The treadle response becomes highly stereotyped and interresponse time distributions obtained from terminal behavior appear very similar to data obtained from rats. It is concluded that the difficulty in training pigeons to avoid electric shock is not in establishing avoidance behavior but in attempting to evaluate such behavior with the key-peck response.

Several years ago, the senior author attempted to train pigeons to avoid unsignaled shocks by key pecking. While some avoidance pecking was shaped, the response rapidly dropped out and was replaced by wing flapping and jumping against the panel containing the keys. While generally ineffective, these responses did occasionally result in key operations, and the wing-flapping and jumping behaviors were maintained. Recently, the difficulty of training escape and avoidance in pigeons has been brought to our attention in the literature (Dinsmoor, 1968). Hoffman and Fleshler (1959) attempted to train pigeons to terminate shock by pecking a key. After repeated failure to condition key pecking in the escape situation, the investigators re-defined the escape response and made termination of shock contingent on head lifting. Using the head-lifting response, they were able to condition escape behavior easily in their pigeons. Hoffman and Fleshler also reported some success at obtaining discriminated avoidance behavior in one bird, although some 3500 tone-shock pairings were required before the bird learned to avoid 80% of the scheduled shocks. Rachlin and Hineline (1967) reported considerable difficulty in training pigeons to peck keys to escape a pulsing shock. They stated

that "the difficulty seems to be due, at least partly, to variations in the pigeons' sensitivity to shock" (Rachlin and Hineline, 1967, p. 955). They suggested that the shock intensity given individual birds must be held within a narrow band in order to be effective in maintaining escape behavior. Using a special conditioning technique, these authors demonstrated that once established, pecking can be maintained under fixed-ratio and fixed-interval escape schedules (Hineline and Rachlin, 1969). Macphail (1968), who also noted the difficulty in training pigeons to key peck on escape and avoidance schedules, reported successful conditioning in four birds on a discriminated avoidance task when the response was to move from one compartment to another in a one-way shuttle box. Similarly, Bedford and Anger (1968) reported successful discriminated avoidance when the response was defined as flight from one perch to another in essentially a shuttle-box situation.

These studies suggest that the problem is not in training birds to escape or avoid aversive stimuli, but rather in attempting to evaluate escape or avoidance behavior with the key-peck response. This should not surprise investigators acquainted with the natural response repertoire of pigeons. The pecking response occurs during appetitive or aggressive activity, while flying and running represent effective response systems for avoiding or escaping noxious situations. One aspect of the unconditioned response (UCR) when shock is adminis-

<sup>1</sup>The work described in this paper was supported by Grant 153-512546 from the University of Utah Research Fund. Reprints may be obtained from R. F. Smith, Department of Psychology, University of Utah, Salt Lake City, Utah 84112.

tered through the pubic arch (Azrin, 1959) is an upward tilting of the head. This response seems to be directly opposed to the response of key pecking. A treadle response, on the other hand, appears to be quite compatible with other aspects of the UCR, such as jumping and wing flapping. Such a response is, of course, analogous to bar pressing and shares with bar pressing the advantages of high rate and relatively simple topography not available in the shuttle-box situation.

The present experiment demonstrated the ease of conditioning and stable behavior obtained on a free-operant avoidance schedule when pigeons were trained to avoid shock by pressing a foot treadle.

## METHOD

### Subjects

Five experimentally naive, male pigeons were conditioned at approximately six months of age. In order to increase the generality of the findings, two Homing, one White King, and two Carneaux pigeons were used. The birds were permitted free access to food and water in their home cages throughout the experiment.

### Apparatus

The apparatus consisted of a Plexiglas box 11.5 in. high by 8 in. wide by 8.5 in. deep (29.2 by 20.3 by 21.6 cm). A "foot treadle", 2.25 in. long by 3.5 in. wide (5.7 by 8.9 cm) was mounted on the vertical mid-line of the front wall (Fig. 1). The treadle extended 2.5 in. (6.1 cm) into the chamber with its forward edge located 1.25 in. (3.2 cm) above the floor. To facilitate responding, the treadle was inclined from its forward edge at a 30° angle to the floor. A force of 25 g (0.23 N) and a displacement of 0.26 cm were required to activate a switch connected to the treadle.

A white masking noise and a 5-w houselight were presented throughout each session. Electric shock was delivered through a set of gold wire electrodes chronically implanted through the pubic arch (Azrin, 1959). Conventional electromagnetic equipment located in another room was used for scheduling and recording.

### Procedure

A free-operant avoidance procedure as described by Sidman (1953) was used. Shock and interval parameters were held constant

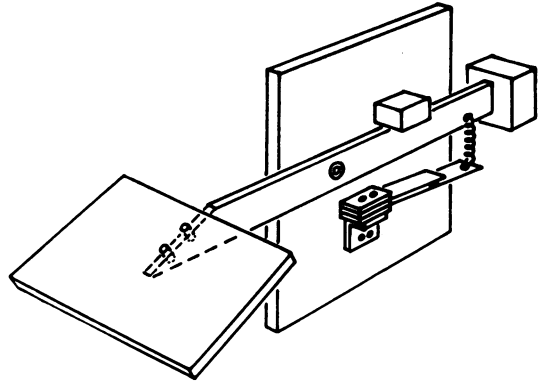

Fig. 1. Diagram of the foot treadle. See text for dimensions.

throughout the experiment. As long as the bird failed to respond, a 6.2-v ac, 250-msec shock was delivered every 10 sec (SS-10 sec). Each time the bird made a treadle response the shock was postponed for 32 sec, *i.e.*, the response-shock interval was equal to 32 sec (RS-32 sec). Holding the treadle down did not result in shock avoidance. Sessions were 90 min in duration, and the experiment was terminated for three of the birds after 20 sessions. The two slowest responders were given three additional sessions so that interresponse time distributions could be obtained.

## RESULTS AND DISCUSSION

Acquisition for all birds occurred quite rapidly. Figure 2 shows the cumulative response curves from Session 1 for the slowest and fastest birds (Birds 3 and 6, respectively). A sample of operant rate precedes the conditioning record for Bird P3. Shocks are depicted by the downward deflections of the pen. Few SS intervals occurred. Instead, the birds tended to make a rapid series of responses immediately after shock and then pause until shock was again delivered. Observation of the birds during their first session revealed high levels of relatively undifferentiated activity (wing flapping, jumping, *etc.*) after shock. This activity resulted in frequent treadle responses. During the following sessions, however, the responses became progressively differentiated and the random activity was virtually eliminated by the fourth session.

Figure 3 shows the number of shocks delivered per session to four of the five birds. Data for Bird 3 were omitted because a broken elec-

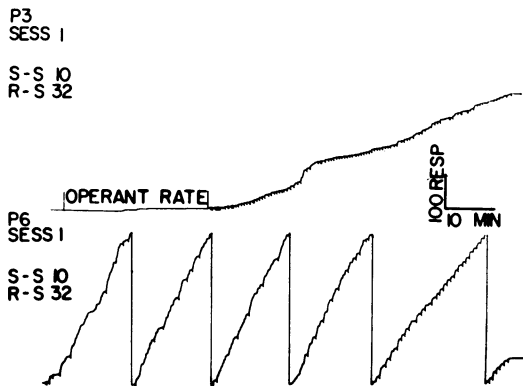

Fig. 2. Treadle responding during the first day of conditioning on an RS 32-sec, SS 10-sec free-operant avoidance schedule. The poorest avoidance responder (P3) and the most successful (P6) are shown. Downward deflections of the pen represent shocks.

treadle connection was undiscovered for several sessions. The connection was repaired before Session 15 and during that session the bird received 100 shocks. Shocks per session then dropped rapidly and only 13 shocks were delivered on the last day of testing. In general, successful avoidance behavior was conditioned in all birds within few sessions. For example, three of the pigeons (P4, P5, and P6) were avoiding better than 98% of the potential shocks (*i.e.*, SS scheduled shocks) by the ninth session. The most successful bird (P6) received no shocks during the last two days of conditioning.

Response stability during the final session is shown in Fig. 4. Again, this figure contains records from the most successful (P6) and least successful (P3) avoidance responders. The

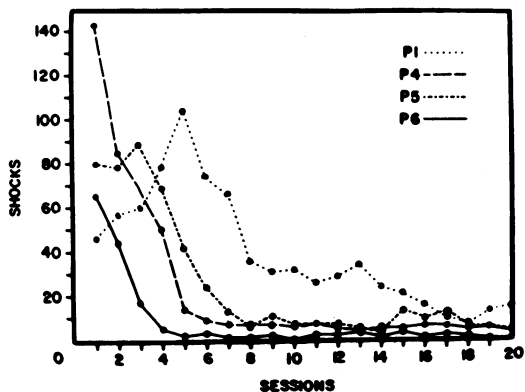

Fig. 3. Absolute number of shocks delivered per 90-min session to four of the five birds. Approximately 540 shocks would have been delivered per session in the absence of responding.

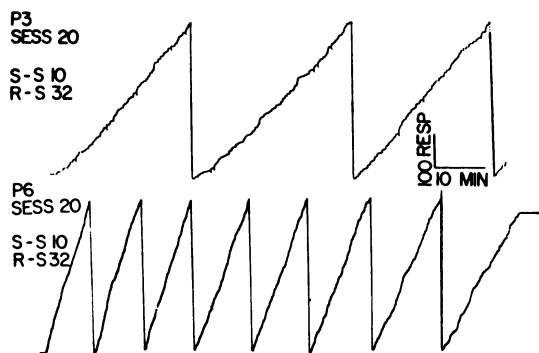

Fig. 4. Terminal treadle performance on the RS 32-sec, SS 10-sec avoidance schedule. The poorest responder (P3) and most successful responder (P6) are shown. Downward deflections of the pen represent shocks. Note that P6 received no shocks during this session.

broken electrode leads (before Session 15) probably contributed to the relatively poor avoidance behavior of P3 during Session 20. By Session 20 response topography was highly stereotyped; the birds tended to leave one foot on the treadle most of the time and simply lift and then replace the foot in order to produce the avoidance response.

In order to obtain terminal interresponse time (IRT) distributions, two birds (P1 and P3) were given three extra sessions and event records were taken during this time. Anger (1956, 1963) has suggested a measure of temporal discrimination that involves X-axis values

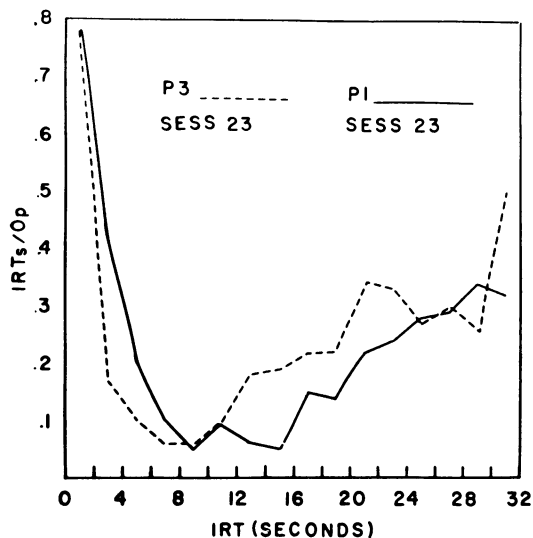

Fig. 5. The interresponse times/opportunity (IRTs/Op) distribution obtained from P1 and P3. The figure includes all IRTs made by these birds during Session 23.

determined by dividing the number of IRTs of a particular duration by the number of exposures to IRTs equal to it or greater. Anger refers to these ratios as IRTs/Ops (interresponse times per opportunity). Figure 5 shows IRTs/Op functions plotted from data obtained during Session 23 for Birds P1 and P3. These birds were chosen because they were receiving the greatest number of shocks (13 and 7, respectively, in Session 23). Had P6 data been selected, the function would be forced to unity in the last IRT bin. That is, since no shocks were delivered, the 30- to 32-sec IRTs would have to equal the opportunities to respond in the 30- to 32-sec bin.

These IRTs/Op curves suggest the presence of a temporal discrimination (as indicated by the increase in IRTs/Op from 8 to 32 sec). Further, the curves are remarkably similar to those obtained from rats [e.g., Sidman's 1954 data replotted by Anger (1963)]. The only clear difference seems to be that the pigeons produce a higher response probability in the short IRT bins. These short IRTs occur in bursts and probably reflect differences in the topography of response for pigeons on a treadle *versus* rats pressing bars.

#### REFERENCES

- Anger, D. The dependence of interresponse times upon the relative reinforcement of different interresponse times. *Journal of Experimental Psychology*, 1956, 52, 145-161.
- Anger, D. The role of temporal discriminations in the reinforcement of Sidman avoidance behavior. *Journal of the Experimental Analysis of Behavior*, 1963, 6, 477-506.
- Azrin, N. H. A technique for delivering shock to pigeons. *Journal of the Experimental Analysis of Behavior*, 1959, 2, 161-163.
- Bedford, J. A. and Anger, D. *Flight as an avoidance response in pigeons*. Paper read at the annual meeting of the Midwestern Psychological Association, Chicago, May 2-4, 1968.
- Dinsmoor, J. A. Escape from shock as a conditioning technique. In M. R. Jones (Ed.), *Miami symposium on the prediction of behavior, 1967: aversive stimulation*. Coral Gables, Florida: University of Miami Press, 1968. Pp. 33-75.
- Hineline, P. N. and Rachlin, H. Notes on fixed-ratio and fixed-interval escape responding in the pigeon. *Journal of the Experimental Analysis of Behavior*, 1969, 12, 397-401.
- Hoffman, H. S. and Fleshler, M. Aversive control with the pigeon. *Journal of the Experimental Analysis of Behavior*, 1959, 2, 213-218.
- Macphail, E. M. Avoidance responding in pigeons. *Journal of the Experimental Analysis of Behavior*, 1968, 11, 629-632.
- Rachlin, H. and Hineline, P. N. Training and maintenance of keypecking in the pigeon by negative reinforcement. *Science*, 1967, 157, 954-955.
- Sidman, M. Two temporal parameters of the maintenance of avoidance behavior by the white rat. *Journal of Comparative and Physiological Psychology*, 1953, 46, 253-261.
- Sidman, M. The temporal distribution of avoidance responses. *Journal of Comparative and Physiological Psychology*, 1954, 47, 399-402.

Received 10 July 1969.