

*CHOICE IN THE TIME-LEFT PROCEDURE AND IN  
CONCURRENT CHAINS WITH A TIME-LEFT  
TERMINAL LINK*

RAY A. PRESTON

UNIVERSITY OF ROCHESTER

In two experiments, rats chose between a standard fixed-duration food-associated stimulus and a stimulus whose duration was the time remaining to reinforcement in an elapsing comparison interval. In Experiment 1, 4 rats responded in a time-left procedure wherein a single initial-link variable-interval schedule set up two potential terminal links simultaneously. As time elapsed in the initial-link schedule, the choice was between a standard fixed-interval 30-s terminal link and a time-left terminal link whose programmed interval requirement equaled 90 s minus the elapsed time in the initial link. Rats generally responded more on the lever with the shortest programmed terminal-link duration, but the temporal parameters of the procedure were found to vary with response distributions. Contrary to previous reports, therefore, time-left data were well predicted by choice models that make no assumptions about animal timing. In Experiment 2, 8 rats responded on a concurrent-chains schedule with independent variable-interval initial links and a time-left terminal link in one of the choice schedules. On the time-left lever, the programmed terminal-link delay equaled 90 s minus the elapsed time in the time-left initial link. On the standard lever, terminal-link responses were reinforced according to a variable-interval schedule whose average value varied over four conditions. Relative time-left initial-link responses increased in the elapsing time-left initial-link schedule as the time-left terminal link became shorter relative to the standard terminal link. Scalar expectancy theory failed to predict the resultant data, but a modified version of the delay-reduction model made good predictions. An analysis of the elaboration of scalar expectancy theory for variable delays demonstrated that the model is poorly formulated for arithmetically distributed delays.

*Key words:* choice, conditioned reinforcement, delay reduction, scalar expectancy, time-left procedure, concurrent chains, lever press, rats

---

As the most prominent models of choice in concurrent chains are collapsing upon a unified molar conception (Killeen & Fantino, 1990; Luco, 1990; Preston & Fantino, 1991; Vaughan, 1985), a series of experiments with a related procedure has been challenging the prevailing view. Gibbon and Church (1981) and Gibbon, Church, Fairhurst, and Kacelnik (1988) argued that the conditioned reinforcement effects evident in concurrent chains are not necessary effects in choice procedures involving choices for food-associated stimuli. They reported data from a variant of the concurrent-

chains schedule, the *time-left* procedure, wherein choice between food-associated stimuli apparently is dependent solely on the times to food in the terminal links.

The time-left procedure is diagrammed in Figure 1. A cycle consists of a choice period (initial link), during which responses can be distributed between two levers, and an outcome period (terminal links), during which responses on one or the other lever will eventually produce food. A single variable-interval (VI) schedule operates during the initial link and simultaneously sets up potential terminal links on both levers. If, after the VI schedule elapses, the first response is on the standard lever, further standard-lever responses are reinforced according to a fixed-interval (FI) *S*-*s* schedule in the presence of the standard terminal-link stimulus; at the same time, the terminal-link opportunity on the other lever is canceled. If the first response is, instead, on the time-left lever, the time-left terminal-link stimulus is presented and further time-left responses are reinforced in the presence of the time-left terminal-link stimulus; the expected

---

I am grateful to Bertram Ploog, Victor Laties, and Randy Pittelli for their comments on various versions of the manuscript. Thanks, too, to Kristina Wehr for her help in conducting the experiments. Special thanks to Marlene Micciche, mostly for her help and support throughout the research but also for critical comments on the manuscript. This research was supported, in part, by NIDA Grants DA04925 and DA00464 and NIEHS Grant ES05433. Correspondence should be addressed to the author, Department of Environmental Medicine, School of Medicine and Dentistry, University of Rochester, Rochester, New York 14642.

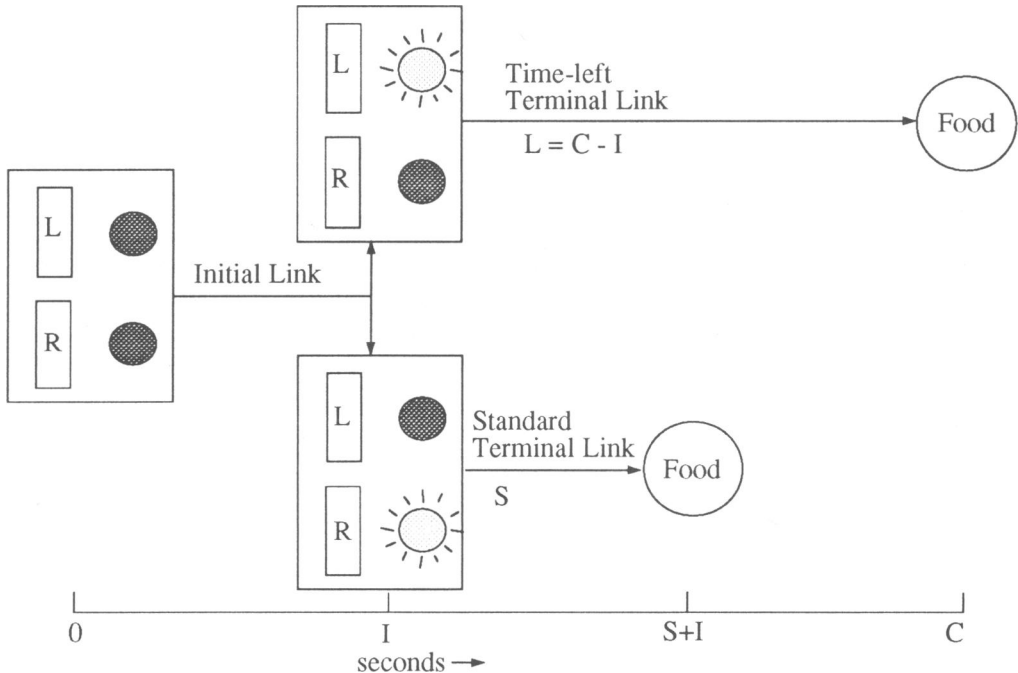

Fig. 1. Time-left procedure. A single initial-link VI schedule simultaneously sets up mutually exclusive terminal links on two levers. If the time-left terminal link is entered, the expected delay to food is  $L = C - I$  s. If the standard terminal link is entered, the expected delay to food is always  $S$  s. Entering one terminal link cancels the opportunity for the other.

duration of the time-left terminal link depends on the elapsed initial-link time at the moment the terminal link is produced. The temporal parameters of the component schedules are determined in relation to the cycle duration ( $C$ ). The standard terminal-link FI schedule requirement,  $S$ , is a fixed proportion of  $C$ , say  $C/2$  s. The programmed time-left terminal-link interval-schedule requirement ( $L$ ) varies as a function of elapsed time ( $I$ ) in the initial link and is equal to  $C - I$  s at any initial-link time,  $I$ . The initial-link VI schedule consists of six intervals evenly distributed over  $C$ , and is  $C/2$  s, on average. Early in the initial link, the programmed time-left terminal link is longer than the standard terminal link. Late in the initial link, the time-left terminal link is shorter than the standard terminal link.

Figure 2, from Gibbon et al. (1988), shows the results obtained from 1 pigeon responding in the procedure. Preference for the time-left terminal link (time-left initial-link responses over total initial-link responses) is plotted in 2.5-s bins of the elapsing initial link ( $C = 60$  s,  $S = C/2 = 30$  s). As is typical, the pigeon

responded more on the key with the shorter programmed terminal-link duration throughout the elapsing initial-link VI schedule; relative time-left responses were near zero early in elapsed initial-link time but rose as a smooth S-shaped function to near exclusive preference for the time-left terminal link late in elapsed initial-link time. Figure 2 also shows the predictions that Gibbon et al. derived from scalar expectancy theory (SET; Gibbon, 1977; Gibbon & Church, 1981)—which predicts preference on the basis of temporal discriminations only—and those of several models of choice and conditioned reinforcement (Davison, 1987; Killeen, 1982; Squires & Fantino, 1971).

In the present paper I argue that all of the predictions shown in Figure 2—excepting those of SET—were derived improperly, and that the time-left procedure is poorly designed as a preparation for studying choice and timing. The experiments reported here examined behavior in two variations of the time-left procedure. Experiment 1 was a simple replication, with rats, of the basic procedure of Gibbon et al. (1988). Experiment 2 was an investigation

of preference in a concurrent-chains schedule with a time-left terminal link in one of the component chained schedules. The procedure of Experiment 2 also differed from that of Experiment 1 in that one of the terminal links consisted of VI rather than FI schedules. Because this required the predictions of SET for choices involving variable delays, the discussion of Experiment 2 includes a review of some possible problems with the way in which SET has been elaborated for this situation.

### EXPERIMENT 1

Whether data from the time-left procedure are appropriate for discriminating between models of choice and animal timing depends on the relationships inherent in the procedure. The predictions derived by Gibbon et al. (1988) for Figure 2 were based on the assumption that the relative rates of primary reinforcement on the two levers were fully determined by the programmed temporal durations of the various schedule components. According to Gibbon et al. (1988, Footnote 3),

the initial-link duration plus terminal-link duration equals  $C$  exactly for the time-left side, and it equals  $C$  on the average when  $S = C/2$  for the standard side. Hence the overall rate of reinforcement is the same for both alternatives.

This is unlikely. There will be equal overall rates of reinforcement on the two alternatives under one condition only: if responding is entirely undifferentiated in relation to the two levers. Assume, for simplicity, that the scheduled terminal-link durations on both levers are the same on every trial. Then it is obvious that the overall relative rate of reinforcement on the time-left lever is simply the overall probability, over trials, of entering the time-left terminal link. If, in 100 trials, 50 trials ended with entry into the time-left terminal link, then the average reinforcement rate on each lever would be 50 divided by the total accumulated session time. If, instead, 80 trials were time-left trials, then the overall rate on the time-left lever would be 80 divided by the total accumulated session time, and the overall rate on the standard lever would be 20 divided by the total accumulated session time. The question then arises, what determines the probability of entering the time-left terminal link in

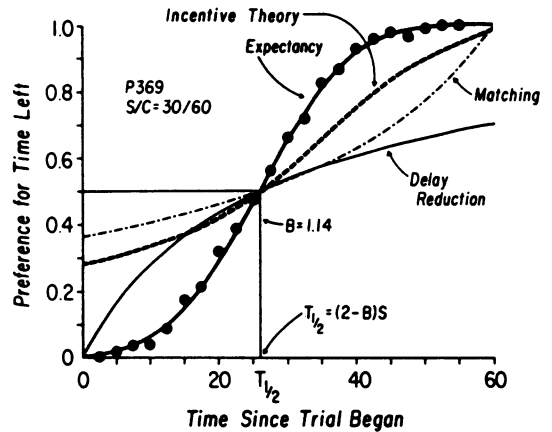

Fig. 2. Preference for the time-left alternative as a function of elapsed time in the initial link from 1 pigeon responding in the time-left procedure with  $C = 60$  s and  $S = C/2 = 30$  s. Also shown are the predictions of scalar expectancy theory (Gibbon, 1977), the delay-reduction model (Squires & Fantino, 1971), incentive theory (Killeen, 1982), and matching (e.g., Davison, 1987). The figure is from Gibbon, Church, Fairhurst, and Kacelnik (1988), © 1988 by the American Psychological Association, reproduced by permission.

a given trial? The probability of entering the time-left terminal link is exactly equal to the relative rate of time-left responses. If, for the conditions of Figure 2 ( $C = 60$  s,  $S = C/2 = 30$  s), there were a constant probability of .5 of responding on the time-left lever, the expected average time to reinforcement on each lever would be 120 s. The average time to food on each lever is twice  $C$  because only half the total food presentations occur on each lever. If, instead, there were a constant probability of .8 of responding on the time-left lever, the expected time to reinforcement on the time-left lever would be 75 s ( $C/.8$ ), and on the standard lever it would be 300 s ( $C/.2$ ). Thus, the relative rate of reinforcement on the two levers would be  $(1/75)/[(1/75) + (1/300)]$ , or .8. The procedure is ratio-schedule-like in the sense that relative rates of terminal-link entries are directly determined by, and must be equal to, relative rates of response. Relative reinforcement rates in the time-left procedure are dependent—not independent—variables (see Gibbon, 1977, for a similar discussion of differential-reinforcement-of-low-rate schedules, and Gibbon et al., with respect to ratio schedules).

The passage from Gibbon et al. (1988),

quoted above, also misdescribes the average trial durations. It is true that the time to food is  $C$  s on trials in which the time-left terminal link is entered. It is not true, however, that standard terminal-link trials will take  $C$  s on the average, except, again, when responding is undifferentiated in the elapsing initial link. Consider, again, a time-left procedure with  $C$  equal to 60 s and  $S$  equal to 30 s ( $S = C/2$ ). Assume that only standard-lever responses occur in the first 10 s of every trial and that only time-left responses occur throughout the remaining initial-link time. Then the average duration of a standard-terminal-link trial would be 35 s (the average terminal-link duration plus 5 s; 5 s is the only initial-link interval shorter than 10 s when  $C$  equals 60 s), not 60 s. The only way for standard-lever trials to average  $C$  s is for standard-lever responses to have a probability of at least .5 throughout the elapsing initial link.

The issue here is not whether obtained schedule values deviate from programmed schedule values. The argument is that previous authors have misidentified the programmed values. It is no more possible to identify the programmed relative reinforcement rates in the time-left procedure than it is to report the programmed temporal rate of primary reinforcement in a variable-ratio schedule. In the time-left procedure, there is no programmed relative reinforcement rate, or programmed relative terminal-link entry rate, or programmed standard-lever trial duration; there are indirectly programmed relations between response allocation and those schedule parameters.

No doubt these concerns have arisen because the procedure has mostly been used to address theoretical questions assumed to be independent of relative reinforcement rates. All of the traditional concurrent-chains models, however, require that the relative terminal-link entry rates or the durations of the various schedule components, or both, be treated as independent variables. Until there is a full accounting of the relationships inherent in the procedure, comparisons like those in Figure 2 will be misleading. Experiment 1, therefore, was a simple replication, with rats, of the procedure of Gibbon and Church (1981) and Gibbon et al. (1988). It was conducted primarily to document the relations between response allocation and the temporal parameters of the time-left procedure and to investigate the im-

plications of those relations for choice and timing models.

## METHOD

### *Subjects*

Four female Long-Evans hooded rats, approximately 9 months old at the start of the experiment, were maintained, through restricted postsession feeding of rat chow, at between 80% and 90% of their free-feeding weights. The rats were housed in pairs in acrylic cages lined with pine bedding and had continuous access to water. All had previously served in a student demonstration project involving continuous reinforcement and extinction; each had extensive experience with food-reinforced responding on the right lever in the same chambers to which they were assigned for the present experiment.

### *Apparatus*

Experimental sessions were conducted in four identical standard operant conditioning chambers (Coulbourn Instruments, Model E10-10TC) with aluminum front, rear, and top panels and clear acrylic side walls, enclosed in a sound-attenuating enclosure (Coulbourn Instruments, Model E10-20) with an exhaust fan in continuous operation. The experimental space was 25 cm wide, 27 cm long, and 30 cm high. The front panel contained two response levers (Coulbourn Instruments, Model E21-03) located approximately 2.5 cm above the floor and 3 cm from the left and right wall, respectively, and a recessed food well located 2 cm above the floor and centered left to right on the panel. Reinforcement consisted of the delivery of a single 45-mg Noyes pellet dispensed into the food well by a Coulbourn pellet dispenser (Model E14-12), accompanied by a 5-s illumination of a lamp located in the food well; during the 5-s reinforcement cycle, all other chamber lights were dark. A minimum force of 0.25 N was required to operate the response levers. A horizontal bank of three stimulus lamps (1 cm diameter), separated center-to-center by 1.5 cm, was located 4.5 cm above each lever. General chamber illumination was provided by a single houselight centered on the front panel and 2 cm from the ceiling. Data recording and scheduling of experimental events were controlled from a

nearby room by a PDP® 11 computer operating under SKED-11® software.

### Procedure

All rats responded on the time-left procedure (Figure 1). One programmed cycle of the procedure lasted  $C$  s, on the average, and began with the onset of a single initial-link VI schedule that set up mutually exclusive terminal links simultaneously on both levers. If the first lever press after the variable interval elapsed occurred on the standard lever, the standard terminal link was produced; lights above the standard lever were illuminated, and responses on the time-left lever had no programmed effect. If the first lever press after the variable interval elapsed occurred on the time-left lever, the time-left terminal link was produced; lights above the time-left lever were illuminated, and responses on the standard lever had no programmed effect. Responses in the standard terminal link were reinforced according to an FI 30-s schedule. In the time-left terminal link, the programmed interval requirement varied from cycle to cycle; on a given trial the interval requirement was equal to the difference between the programmed cycle duration ( $C$ ) and the obtained initial-link time ( $I$ ) in the immediately preceding temporally adjacent initial link. The initial-link VI schedule was constructed from an arithmetic distribution made up of six intervals equal to  $1/12$ ,  $3/12$ ,  $5/12$ ,  $7/12$ ,  $9/12$ , and  $11/12$  of  $C$ , and was  $C/2$  s on the average.

*Preliminary training.* Starting on the 1st day, all rats responded on the time-left procedure with a cycle duration of 60 s and a standard (left-lever) terminal link equal to one half the cycle duration ( $S = C/2 = 30$  s). After 23 sessions, only 2 rats showed evidence of control by the schedule contingencies, so two changes were made: The cycle duration was changed to 90 s, and the levers associated with the time-left and standard schedules were switched so that the right lever was made the standard lever.

*Experimental condition.* Thereafter, responding was maintained on the time-left procedure with  $C = 90$  s and  $S = C/3 = 30$  s for approximately 50 sessions for each rat, until responding appeared stable over the last 10 sessions. Trials were separated by 10-s intertrial intervals, during which all chamber lights were dark and lever presses had no pro-

grammed effect. At all other times, the chamber was illuminated by the houselight. Lever presses resulted in the operation of a feedback relay at all times other than the intertrial intervals and the 5-s reinforcement cycle. Responses and terminal-link entries were recorded in 7.5-s bins during the initial link. Sessions ended after 60 pellets were delivered or after 95 min elapsed, whichever occurred first.

## RESULTS

### Preference

Figure 3 (filled circles) shows preference for the time-left terminal link for each rat, as a function of the elapsed time, in 7.5-s bins, in the initial link. All data are averages of the final 10 sessions. Preference was calculated as the total time-left lever responses in each time bin divided by the sum of the time-left and standard lever responses in that bin. All rats responded almost exclusively on the standard lever early in the initial link (between 0 s and 25 s) and then gradually increased the proportion of initial-link time-left responses to indifference between 42 s and 56 s. In later portions of the initial link, responses occurred primarily on the time-left lever. For each rat, preference for the time-left terminal link increased as a smooth S-shaped function of elapsed time in the initial link. Indifference to the time-left and standard terminal links was estimated for each rat from the solid line fitted to the choice proportions, and is indicated by the initial-link time intersected by the solid vertical line. The numbers of responses on the two levers were equal at 47, 42, 56, and 51 s into the initial link, respectively, for Rats R31, R32, R34, and R35.

### Relative Terminal-Link Entries

The open circles in Figure 3 show relative time-left terminal-link entries as a function of elapsed time, in 15-s bins, in the initial link. Relative terminal-link entries were calculated as the number of time-left terminal links produced in each time bin divided by the total terminal links. Different bin sizes are reported because terminal-link entries were scheduled in 15-s intervals. Relative time-left terminal-link entries varied with the distribution of initial-link responses, increasing in much the same way as the response functions. For all rats, however, relative time-left terminal-link en-

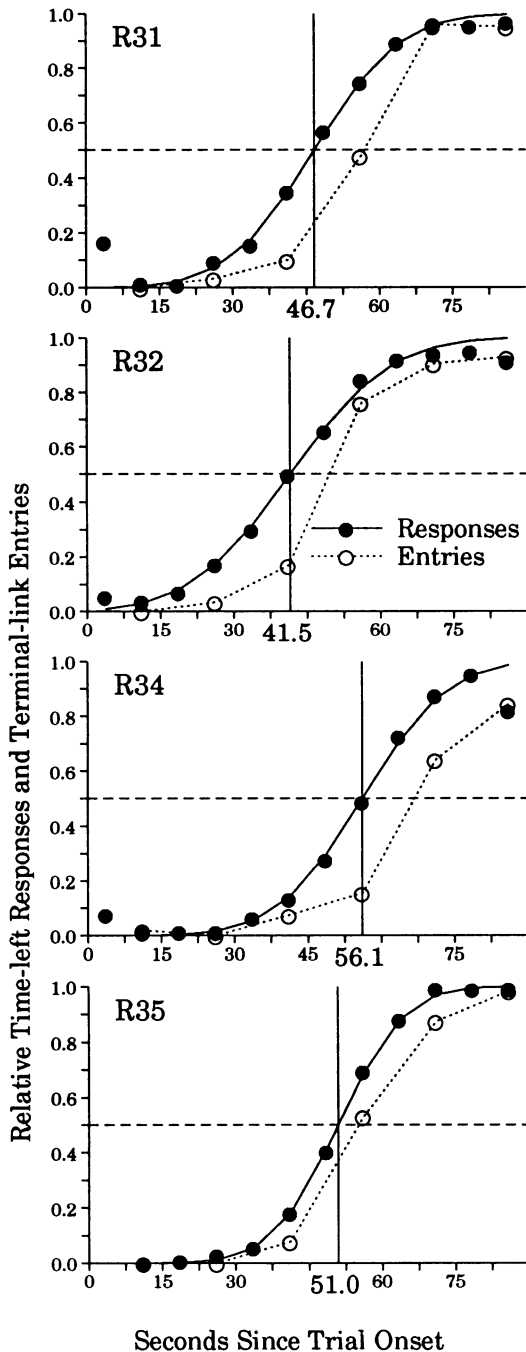

Fig. 3. Preference for the time-left terminal link (expressed as time-left initial-link responses over total initial-link responses), and relative time-left terminal-link entries, in 7.5-s bins of the elapsing initial link in the time-left procedure ( $C = 90$  s,  $S = C/3 = 30$  s; points are not plotted for choice proportions determined by fewer than 10 responses). The solid lines through the relative response data are fitted curves. Data for each rat are averages of 10 sessions.

tries were lower than relative time-left responses throughout the interval. The discrepancy between the relative response functions and the relative entry functions indicates that the local response rates on the two levers were not equal; that is, there was a bias in favor of the time-left lever for all animals. Rat R34, for instance, produced time-left local response rates (total time-left responses divided by total time spent actually responding on the time-left lever) that were approximately twice the local response rates on the standard lever. Gibbon and Church (1981) and Gibbon et al. (1988) reported a similar bias for pigeons responding in the time-left procedure. When the response data are adjusted for lever bias, the discrepancy between the relative response and relative entry curves is greatly reduced (see the sections Predicting Preference in the Time-Left Procedure and Animal Timing and the Time-Left Procedure, both below). The critical feature of the data is that relative entries ranged from approximately 0.0 to 1.0 over the elapsing initial link and increased as a function of relative responses. The actual relative entry functions differed from the nominal expected values because of the indirectly programmed relation between relative responses and relative entries in the time-left procedure. Again, relative time-left entries are directly determined by relative time-left responses in the time-left procedure.

#### Schedule Durations

Figure 4 shows, for each rat, the average initial-link and terminal-link durations, in seconds, separately, on trials in which the time-left or standard terminal link was entered. Also shown is the average overall time to food for each rat. The unfilled bars, from left to right for each measure, show the data from Rats R31, R32, R34, and R35. The hatched bars show the group mean of each measure. The solid bars show the nominal programmed durations of the various schedule components, determined with the assumption of temporally indiscriminate responding on the two levers. Both the time-left and standard initial-link schedule durations differed from nominal values, as is expected given the programmed relationship between relative time-left responses and relative time-left entries. The average initial-link duration on time-left trials (trials in which the time-left terminal link was entered)

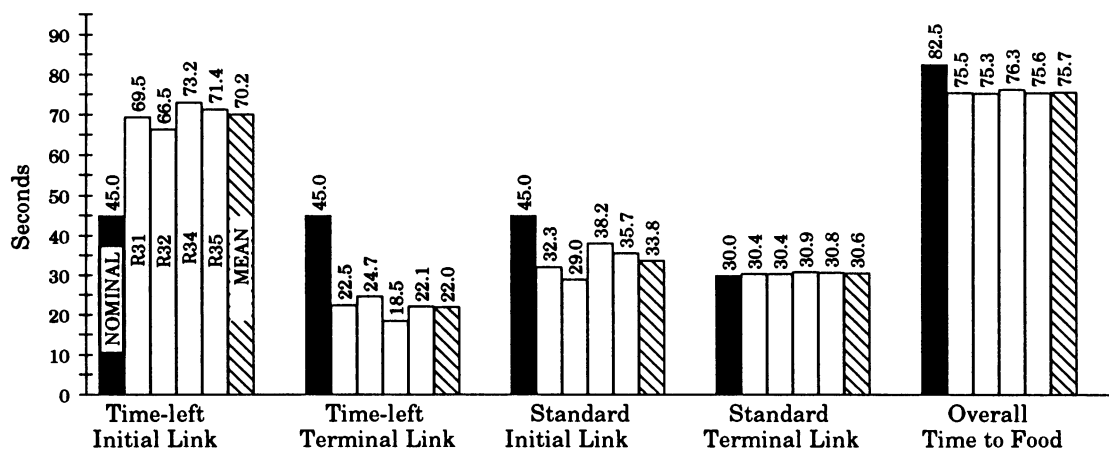

Fig. 4. Nominal programmed (solid bars) and actual (open bars) mean initial-link durations, terminal-link durations, and overall average delays to food, for 4 rats responding in the time-left procedure ( $C = 90$  s,  $S = C/3 = 30$  s). The values are plotted separately for the time-left and standard levers. The hatched bars show the group-average obtained schedule durations.

was 70.2 s, averaged over rats, or about 157% of the nominal value (45 s). The average initial-link duration on standard trials was 33.8 s, approximately 75% of the nominal value (45 s). The average time-left terminal link was approximately 22 s, and the average standard terminal-link duration was approximately as programmed (30 s). The overall delay to food was 75.7 s, averaged over rats, or about 91% of the nominal average delay (82.5 s). In summary, all rats responded so as to shorten the average time to reinforcement on the standard lever, and consequently to shorten the overall time to reinforcement in the conditioning situation.

## DISCUSSION

### *Predicting Preference in the Time-Left Procedure*

Given the discrepancies between the nominal and actual programmed schedule values in the time-left procedure, it becomes necessary to reconsider the predictions shown in Figure 2. As stated above, the predictions of the several models were based on faulty assumptions about the programmed relations that are obtained in the time-left procedure. The delay-reduction model (in the form discussed by Luco, 1990) and the matching model (e.g., Davison, 1987) both require that the relative rates of terminal-link entries be treated as independent variables in order to predict relative response rates. It has been argued here, however, that relative

response rates, relative terminal-link entry rates, and some of the average schedule delays are all dependent variables in the time-left procedure. In the interest of rectifying the impression given by Figure 2, it is necessary to examine the predictions of the models when the obtained entries and the obtained schedule durations are taken into account.

Figure 5 shows the results from Rat R34 replotted after adjusting for time-left lever bias and after regrouping the response data into bins equal in size to the entry bins. In order to factor out the time-left lever bias, the overall local response rates on the time-left and standard levers were determined, and then the total time-left responses in each bin were divided by the ratio of time-left to standard local response rates (for Rat R34, 2.09). Preference in each bin was then recalculated using the bias-adjusted time-left responses per bin. For Rat R34, this resulted in relative responses that correspond more closely to the relative entries. Also shown are the predictions of SET (Gibbon et al., 1988), the generalized matching model (e.g., Davison, 1987), and the delay-reduction model (in the form discussed by Luco, 1990), each based on the obtained schedule values. The details of the models will be discussed in Experiment 2. Only the specific parameter values that affected the predictions are presented here.

*Scalar expectancy theory.* Because the predictions of SET do not depend on the obtained relative reinforcement rates on the two levers,

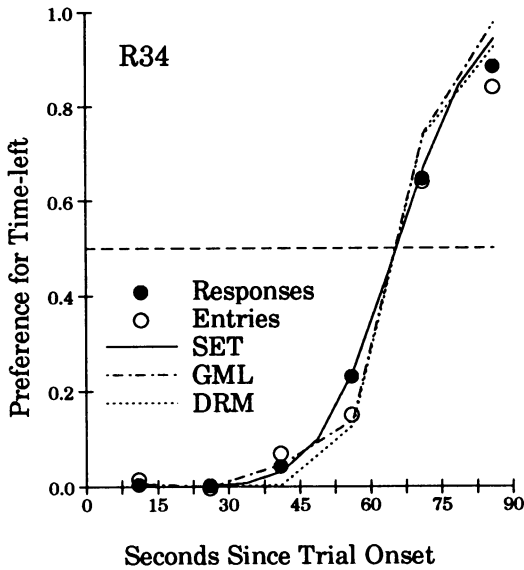

Fig. 5. Relative time-left responses and time allocation for Rat R34. Also shown are the predictions of scalar expectancy theory, the generalized matching model, and the delay-reduction model. The predictions of the several models were derived using obtained schedule parameters.

the predictions in Figure 5 differ from those derived by Gibbon et al. (1988) only in the incorporation of the obtained time-left cycle duration ( $C = 91.7$  s) and standard terminal-link duration ( $S = 30.9$  s). The predictions were also adjusted, as usual, by varying gamma, the sensitivity parameter in SET, and a bias term in the model until the fit to the data was adequate.

*Matching model.* The matching predictions differ from those derived from Gibbon et al. (1988) only in that the relative entries were incorporated into the equation. No adjustment was made for sensitivity to relative rates of entries or relative terminal-link delays, and no further adjustment was made for lever bias.

*Delay-reduction model.* The predictions of the delay-reduction model differ from those derived by Gibbon et al. (1988) in three ways. First, delay reduction requires for its predictions the overall average delay to food in the conditioning situation; the modified predictions incorporated the obtained value of this parameter. Second, the calculated relative reinforcing values of the terminal-link stimuli require the mean durations of the two terminal links; the obtained values were used. Third, the relative entry rates were incorporated into

the equation. The predictions of delay reduction would have been much the same without the first two adjustments—the primary determinant of the improved predictions is the incorporation of the relative entries. As with the matching model, the delay-reduction predictions were made with no free parameters.

The general conclusion to be drawn from Figure 5 is that all of the models fit the data reasonably well when the actual schedule values are taken into account. The fits of the matching model and delay reduction could have been further improved by incorporating free parameters for bias or sensitivity to terminal-link frequencies or values. The fit of SET could have been improved by incorporating, as is usual, free parameters for inattention, response-execution times, and timing latencies. For the matching and delay-reduction models, however, the improved fits are not really meaningful; the improvement was gained by ignoring the distinction between independent and dependent variables. It should come as no surprise that relative response rates are predicted, so to speak, by relative entry rates when the latter are caused by the former.

#### *Animal Timing and the Time-Left Procedure*

The foregoing analysis of the relations obtaining in the time-left procedure have two implications for how the data have been interpreted with respect to animal timing. The first is that estimates of timing sensitivity obtained from the procedure may reflect nontiming processes. The time-left procedure reliably produces SET sensitivity estimates (e.g., gamma approximately 0.15 for Rat R34) that indicate timing sensitivity on a par with only the most precise performances from other procedures (Gibbon & Church, 1981). In contrast, gamma was estimated by Gibbon (1977) to be around 0.7 for pigeons choosing between different terminal-link delays in the concurrent-chains procedure of Chung and Herrnstein (1967). Gibbon and Church also noted that the extreme sensitivity apparent in the initial link of the time-left procedure was not evident in the terminal-link performances. One explanation of the high sensitivity estimates for time-left performances may be the indirectly programmed relationship between relative responses in the initial link and the overall rate of reinforcement delivered by the procedure. It is possible to calculate, for different response



distributions in the time-left procedure, the expected average time to reinforcement by summing over the expected proportions of time-left and standard terminal links multiplied by their expected terminal-link durations at each point in the elapsing initial link. Figure 6 shows how the expected average time to reinforcement varies with the shape of the preference function. In the top panel are shown five possible functions, all derived from SET, for preference in a time-left procedure with  $C = 90$  s and  $S = C/3 = 30$  s. The functions differ only in the time-sensitivity index,  $\gamma$ , normally a fitted parameter in SET. The bottom panel shows the programmed average time to food as a function of  $\gamma$ . Of interest is the fact that more nearly instantaneous transitions from preference for the standard to preference for the time-left terminal link result in shorter times to food. This dependency adds to the difficulty of interpreting the data produced by the procedure. Even if the processes hypothesized by SET were acting to determine how time controls behavior in the situation, it seems likely that preference would also be influenced by the programmed dependence of overall reinforcement rates on the distribution of choice responses. Because the highest overall rate of reinforcement is produced only when preference changes abruptly around the indifference point, it is not surprising that the functions should take that shape, no matter what the mechanisms are that determine the point of indifference.

The second implication of Experiment 1 is that relative responses may not be the best choice of dependent variable when the procedure is used to investigate animal timing. The discrepancy between relative responses and relative entries (Figure 3) indicates that relative responses may be biased estimates of time discriminations. For the discrepancy to arise, subjects must respond at higher local rates on the time-left than on the standard lever. If the bias is constant in initial-link time, as was assumed for the reanalysis of the data of Rat R34 in Figure 5, then it is trivial to factor out the bias in timing estimates. The data in Figure 3, however, suggest that relative local response rates may change in an orderly way in the elapsing initial link; this seems likely, because the relative response and relative entry curves are not identical curves displaced along the time axis. The relevant data were not col-

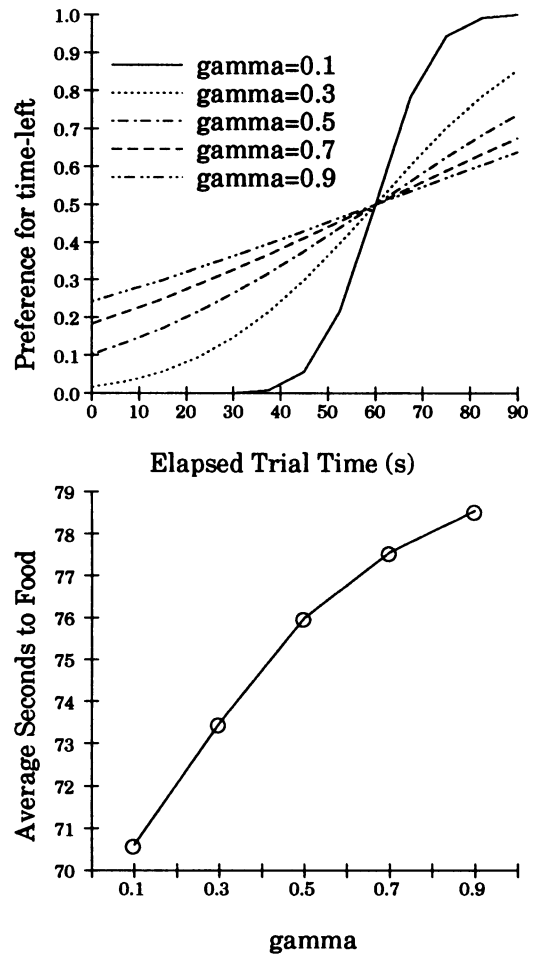

Fig. 6. (Top) Theoretical predictions of scalar expectancy theory for preference in the time-left procedure ( $C = 90$  s,  $S = C/3 = 30$  s). The different curves are for different values of  $\gamma$ , the time-sensitivity index in scalar expectancy theory. (Bottom) Expected overall delays to food in the time-left procedure ( $C = 90$  s,  $S = C/3 = 30$  s) as a function of  $\gamma$ . Lower  $\gamma$  values (greater time sensitivity) produce shorter overall expected delays.

lected here, but Preston, Laties, and Khunger<sup>1</sup> reported local response rates in a replication of Experiment 1 using one of the same rats (R31). (The replication followed seven intervening conditions of a variation of the time-left procedure with different food amounts in the two terminal links.) Figure 7 shows 10-session averages of relative responses, relative

<sup>1</sup> Preston, R. A., Laties, V. G., & Khunger, M. L. (1992, May). *Choice for reinforcers differing in amount and delay*. Paper presented in the 18th annual convention of the Association for Behavior Analysis, San Francisco.

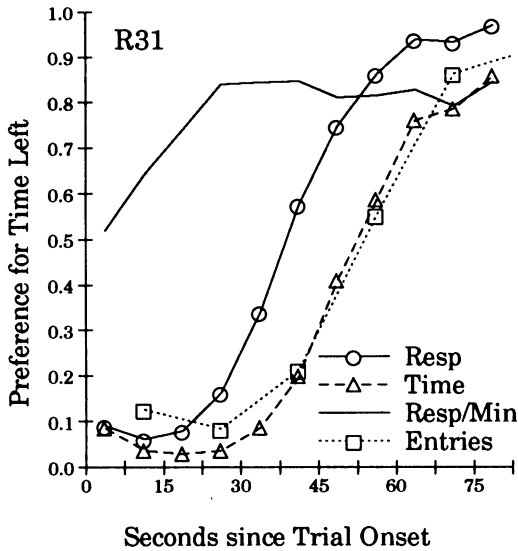

Fig. 7. Relative time-left responses, time allocation, local response rates, and terminal-link entries as a function of elapsing initial-link time from 1 rat responding under the time-left procedure ( $C = 90$  s,  $S = C/3 = 30$  s). The data are from Preston, Laties, and Khunger (see Footnote 1).

time allocation, relative local response rates, and relative terminal-link entries for Rat R31 responding in the same procedure and condition as in Experiment 1. Relative time allocation was more closely related to relative terminal-link entries than were relative responses, as is expected given the programmed contingencies. It seems, therefore, that relative time allocation, being the operative dimension of behavior in the procedure, might be a more appropriate measure of time discriminations. Response measures are further suspect inasmuch as the relative local response rates were not constant in the elapsing initial link. Relative local rates were approximately .5 early in the elapsing initial link but increased in favor of the time-left lever over the first 25 s or so. This means that a single bias parameter, fitted for the data of a given condition, cannot render the two measures equivalent, at least not over the full range of initial-link times.

### Conclusions

Although the indifference points obtained from animals responding under the time-left procedure may be relevant to some theoretical questions (see, e.g., Gibbon & Church's, 1981, comparison of linear and logarithmic timing

models), the procedure does not produce data that allow comparison of SET with the various extant choice models. Instead, the independent variables incorporated into the concurrent-chains models are dependent variables in the time-left procedure, and it becomes more or less a tautology that the choice models will predict the resultant data. That the distribution of responses must affect the overall time to food is less than ideal for the study of timing as well. No procedure that involves the response-dependent presentation of stimuli can guarantee precise control of temporal parameters, but the time-left procedure is especially worrisome because it puts the temporal parameters directly under the control of responses.

## EXPERIMENT 2

Experiment 1 showed that the time-left procedure was not an appropriate preparation for contrasting models of choice and animal timing because the obtained schedule durations are largely determined by the distribution of responses and therefore vary from the nominal schedule values. Experiment 2, therefore, presents an alternative procedure that retains the elapsing delay feature of the time-left procedure while controlling the dependent variables required by the traditional concurrent-chains choice models. Preference was examined in a concurrent-chains schedule with a time-left terminal link in one of the component chained schedules. Two independent VI 45-s initial-link schedules arranged terminal links on two levers. On the time-left lever, the terminal-link interval requirement was always 90 s ( $C$ ) minus the elapsed time-left initial-link time ( $I$ ), and was 45 s on the average. The programmed delay to food on the time-left lever was, thus, exactly 90 s from the onset of the time-left initial-link schedule. The programmed standard terminal-link interval requirement varied from trial to trial, and was  $C/d$  s on the average (a VI  $C/d$ -s schedule), with  $d$  varying over conditions. The procedure differs from the time-left procedure in that the programmed relative durations of the two terminal links depend on the time since the last time-left food presentation, but are independent of elapsing time in the standard initial link. Of interest are the relative time-left responses as a function of elapsed time in the

time-left initial-link schedule. At any time,  $I$ , in the elapsing time-left initial link, rats were faced with a choice between a standard terminal link, in which the expected delay to food was  $C/d$  s, and a time-left terminal link, in which the expected delay was  $90 - I$  s. The programmed expected terminal-link schedule requirements were equal when  $I$  equaled  $90 - S$  s.

The procedure contains three likely sources of control over relative initial-link responses. First, preference might be a function solely of the average initial-link and terminal-link schedule values (as they are in normal concurrent-chains schedules) and therefore constant in the elapsing time-left and standard initial links. Second, preference might also be affected by the changing programmed terminal-link-entry probabilities in both elapsing initial links. If so, preference for the time-left terminal link would be an increasing function of the elapsing time-left initial link, but a decreasing function of the elapsing standard initial link. Third, preference might be controlled by the changing relative terminal-link schedule values in the time-left initial link, producing increasing preference for the time-left terminal link in the elapsing time-left initial link and constant preference for the time-left terminal link in the standard initial link.

## METHOD

### *Subjects and Apparatus*

Eight female Long-Evans hooded rats, approximately 9 months old at the start of training, were maintained through restricted post-session feeding of rat chow at between 80% and 90% of their free-feeding weights. All had served as subjects in variations of the time-left procedure unrelated to the present concerns. All were maintained under the same conditions as the rats in Experiment 1. The same conditioning chambers were used as in Experiment 1.

### *Procedure*

*General procedure.* All rats' responses were reinforced according to a concurrent-chains schedule. During an initial-link (choice) period, responses on the left and right levers produced terminal-link stimuli according to concurrent and independent VI schedules. On each lever, the first response following the lapse of

the interval requirement was reinforced by the onset of the stimulus lamps above the lever (terminal-link stimulus). Responding in the presence of each terminal-link stimulus was eventually reinforced by the delivery of a food pellet. When either terminal link was produced, the other lever became inoperative and timing of the schedules on the inoperative lever was interrupted until the initial links were again present. Reinforcement consisted of the delivery of one 45-mg Noyes pellet accompanied by a 2-s illumination of the feeder light, followed by an 8-s intertrial interval during which no chamber lights were illuminated.

The programmed left-lever (time-left) schedule values were determined in the same manner as those for the time-left lever of Experiment 1. The programmed delay to food on the time-left lever (the time-left cycle duration,  $C$ ) was exactly 90 s from the onset of the time-left initial-link schedule. The initial-link VI schedule was exactly as in Experiment 1 (i.e., a VI 45-s schedule made up of six intervals equal to  $1/12$ ,  $3/12$ ,  $5/12$ ,  $7/12$ ,  $9/12$ , and  $11/12$  of  $C$ ). The programmed time-left terminal-link duration ( $L$ ) was  $C$  minus the elapsed time-left initial-link time ( $I$ ) at the moment of time-left terminal-link entry.

The programmed right-lever (standard) initial-link schedule was the same as for the time-left lever. The standard terminal-link VI requirement varied from trial to trial and was equal to  $S = C/d$  seconds on the average. The divisor,  $d$ , was varied over conditions. The standard terminal-link VI schedule was made up of the same intervals as the initial-link schedules, multiplied in each condition by  $2/d$ . When  $d = 2$ , the standard terminal-link schedule is the same as the average programmed time-left terminal-link schedule. When  $d = 3$ ,  $S = 90/3$  s, or 30 s, on the average, and is made up of six distinct intervals each equal to two thirds of the initial-link intervals. When  $d = 2$ , therefore, the average schedule values in both initial links and both terminal links are equal to 45 s. The programmed duration of the standard terminal link varies with  $d$ , but all other programmed schedule values are unaffected.

The procedure differed from the time-left procedure of Experiment 1 in that the programmed relative durations of the two terminal links depended on the time since the last time-left food presentation, but were indepen-

dent of elapsed time in the standard initial link. Of interest are the relative time-left responses as a function of elapsed time in the time-left initial-link schedule. At any time,  $I$ , in the elapsing time-left initial link, the rats were faced with a choice between a standard terminal link, in which the expected terminal-link duration was  $S = C/d$ , and a time-left terminal link, in which the expected duration was  $L = 90 - I$  s.

*Experimental conditions.* All rats responded on the modified concurrent-chains schedule ( $C = 90$  s in all conditions) with  $S = C/3 = 30$  s for 35 sessions,  $S = C/2 = 45$  s for 25 sessions, and  $S = C/6 = 15$  s for 25 sessions. This was followed by one more condition of 25 sessions. For Rats R20 through R23,  $S = C/4 = 22.5$  s were the parameters in the final condition;  $S = C/8 = 11.25$  s were the parameters for Rats R40 through R43. For all the rats in all conditions, the time-left chained schedule was programmed on the left lever and the standard chained schedule was programmed on the right lever. Sessions ended after 60 min or after 60 pellet deliveries, whichever occurred first. Lever presses resulted in the operation of a feedback relay and illumination of the houselight at all times other than 10-s reinforcement-plus-timeout cycle.

## RESULTS

The potential value of the results of Experiment 2 depends primarily on whether the distribution of initial-link responses is an orderly function of elapsed time in the time-left initial link. It must be shown, in other words, that animals prefer the time-left terminal link relatively less early in the time-left initial link (when the expected time-left terminal-link duration is long) but relatively more late in the time-left initial link (when the expected time-left terminal-link duration is short). Simply plotting the relative time-left responses as a function of elapsing time-left initial-link time, however, will not suffice, even if the data are orderly and produce the desired result. Whenever two independent concurrent VI schedules arrange reinforcement on two levers (as in the initial links of Experiment 2), the relative probabilities of reinforcement on the two levers change in the two elapsing postfood intervals. The longer the time since reinforcement on a lever, the higher is the overall probability that reinforcement is available on that lever, even

though meanwhile none or many reinforcers might have been delivered by the other schedule. In concurrent chains, then, the probability of a terminal link on one of the levers depends on the time since food on that lever but is independent of the time since food on the other lever. These relations alone might be expected to produce relative time-left initial-link responses that are increasing in the elapsing time-left initial link. The conclusion that responding was sensitive to the changing relative terminal-link durations, therefore, requires the demonstration that behavior in the time-left initial link was orderly in a way not also evident in the standard initial link. In many of the figures that follow, therefore, data are graphed separately over the two dimensions (the time since the last time-left reinforcer and the time since the last standard reinforcer). In general, preference might be influenced by (a) the temporal differentiation of the relative terminal-link schedule values in the time-left initial link, (b) the changing relative terminal-link entry probabilities in the time-left and standard initial links, (c) the average schedule values independent of the time-left feature on the time-left lever, or (d) some combination of these. Both the programmed relative terminal-link schedule requirements and the programmed relative terminal-link entry probabilities increase in favor of the time-left lever as the time-left initial link elapses. In the elapsing standard initial link, the programmed relative terminal-link schedules are constant, but the relative terminal-link entry probabilities change in favor of the standard lever.

### *Relative Responses in the Time-Left Initial Link*

Figure 8, in the left column of graphs, shows preference for the time-left terminal link as a function of elapsed time in the time-left initial link, averaged over the last 10 sessions separately for each rat and each condition. Points are not plotted for initial-link times greater than 82.5 s because there were relatively few opportunities for responding in the last time bin. Preference generally was a monotonically increasing, concave down, function of elapsed initial-link times, with an intercept near zero and an asymptote well below 1.0 as initial-link times grew large. The bottom left graph in Figure 8 shows preference for each condition separately, averaged over rats. Preference for the time-left terminal link grew more

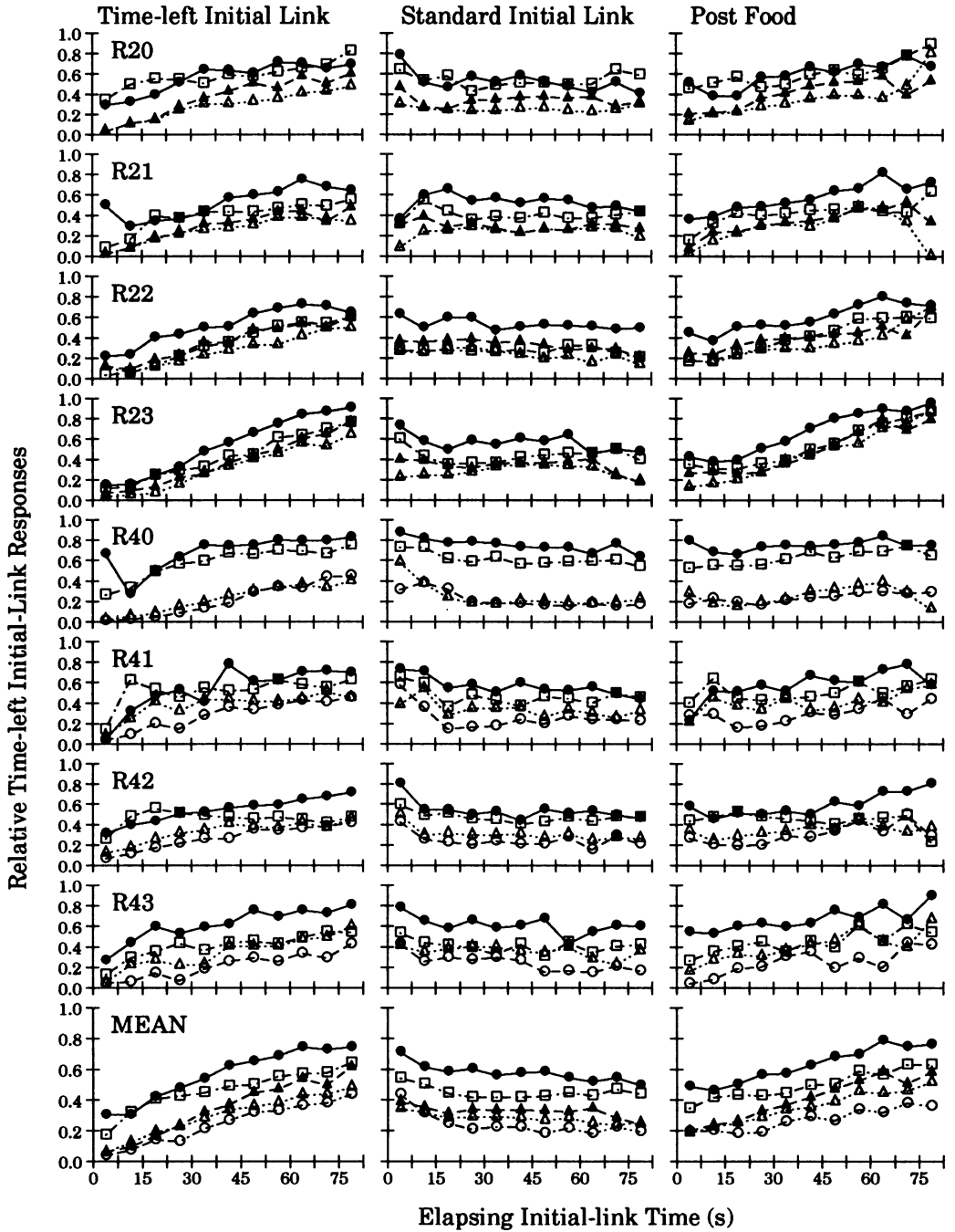

Fig. 8. Relative time-left responses as a function of time in the time-left initial link (left column of graphs), time in the standard initial link (center column of graphs), and time since food on either initial link (right column of graphs) for 8 rats responding in a concurrent-chains schedule with a time-left terminal link. The different curves for each rat are for different mean values for the standard terminal link:  $S = 45$  s (filled circles),  $S = 30$  s (squares),  $S = 22.5$  s (filled triangles),  $S = 15$  s (open triangles), and  $S = 11.25$  s (open circles).

quickly, and approached higher asymptotes, with longer standard terminal-link VI requirements. For some rats and conditions (e.g., Rats R21 and R40 in the  $S = C/2 = 45$  s condition), relative time-left responses were elevated in the first bin. This is mostly due to a latency to begin responding after food presentations, and therefore to relatively few responses entering into the choice proportions. For example, 20 total responses (over 10 sessions) entered into the first point for Rat R40 in Condition  $S = C/2 = 45$  s, but an average of 216 responses were made in each of the other 11 initial-link bins. Relative responses in the first bin or two are, in any case, questionable measures of relative terminal-link reinforcing values in concurrent chains. Killeen (1970) and Fantino and Royalty (1987) reported a negative recency effect in concurrent chains with independent VI schedules in the initial links. For 10 to 15 s after food on one key, pigeons responded at elevated rates on the other key. In the left column of Figure 8, this would show up as low relative response rates in the first bin or two.

#### *Relative Responses in the Standard Initial Link*

The center column in Figure 8 shows preference for the time-left terminal link as a function of elapsed time in the standard initial link; the group means are plotted in the bottom center graph. For most rats, preference for the time-left terminal link decreased over the first one or two bins and then was constant throughout the remaining elapsing standard initial link. After the first bin, the several curves are best described as lines with slopes equal to zero, but with intercepts that varied with the average standard terminal-link VI requirement. Relative time-left responses were higher when the standard terminal-link VI requirement was long than when the standard VI was short. The elevated preference in the early bins is similar to that reported by Killeen (1970) and Fantino and Royalty (1987). In contrast to preference in the time-left initial link, relative responses were essentially insensitive to elapsed standard initial-link time.

#### *Relative Responses in the Time Since Food*

For comparison, the right column of Figure 8 shows preference for the time-left terminal link as a function of elapsed time in either initial link (i.e., time since the last reinforcer

on either lever). The group means are shown in the bottom right graph. Because relative responses were relatively constant in the elapsing standard initial link and increased in the elapsing time-left initial link, preference is expected to be moderately increasing in the time since the last food presentation on either lever. The data might also be expected to be more variable, because response opportunities are more quickly diminished in this dimension than in the elapsing time-left or standard initial links. For a response to occur in the last bin, for example, the longest possible interval must be simultaneously in effect in both initial-link VIs and, moreover, the previous terminal-link entries on the two levers must occur within 7.5 s (in initial-link time) of one another. For most rats, preference for the time-left terminal link increased over the time since food, but to a lesser degree than in the time-left initial link.

#### *Relative Time-Left Time Allocation*

Figure 9 shows relative time-left time allocation as a function of elapsed time-left initial-link time (left column of graphs), elapsed standard initial-link time (center column of graphs), and time since food on either lever (right column of graphs). Group means are plotted in the bottom graph of each column. Relative times changed over elapsing initial-link time in essentially the same manner as relative responses, with a couple of exceptions. First, there was a more pronounced elevation of time-left time allocation in the early bins of the standard initial link than was obtained with relative response measures. This is related to the way in which time allocation is measured; a single response in the first time bin has the effect of allocating all the available time through successive bins until the next response occurs. This gives the appearance of a more gradual decrease in preference over successive bins, whereas it probably reflects a latency to begin the vigorous responding that allows more meaningful preference measurement. Also, Rats R23 and R41 produced uniformly decreasing time-allocation functions in the standard initial link in the  $S = C/2 = 45$  s condition. In general, however, the functions are much like those of the relative responses in Figure 8. Relative time allocation increased over the time-left initial link and, excepting the first couple of bins, was generally constant in the standard initial link.

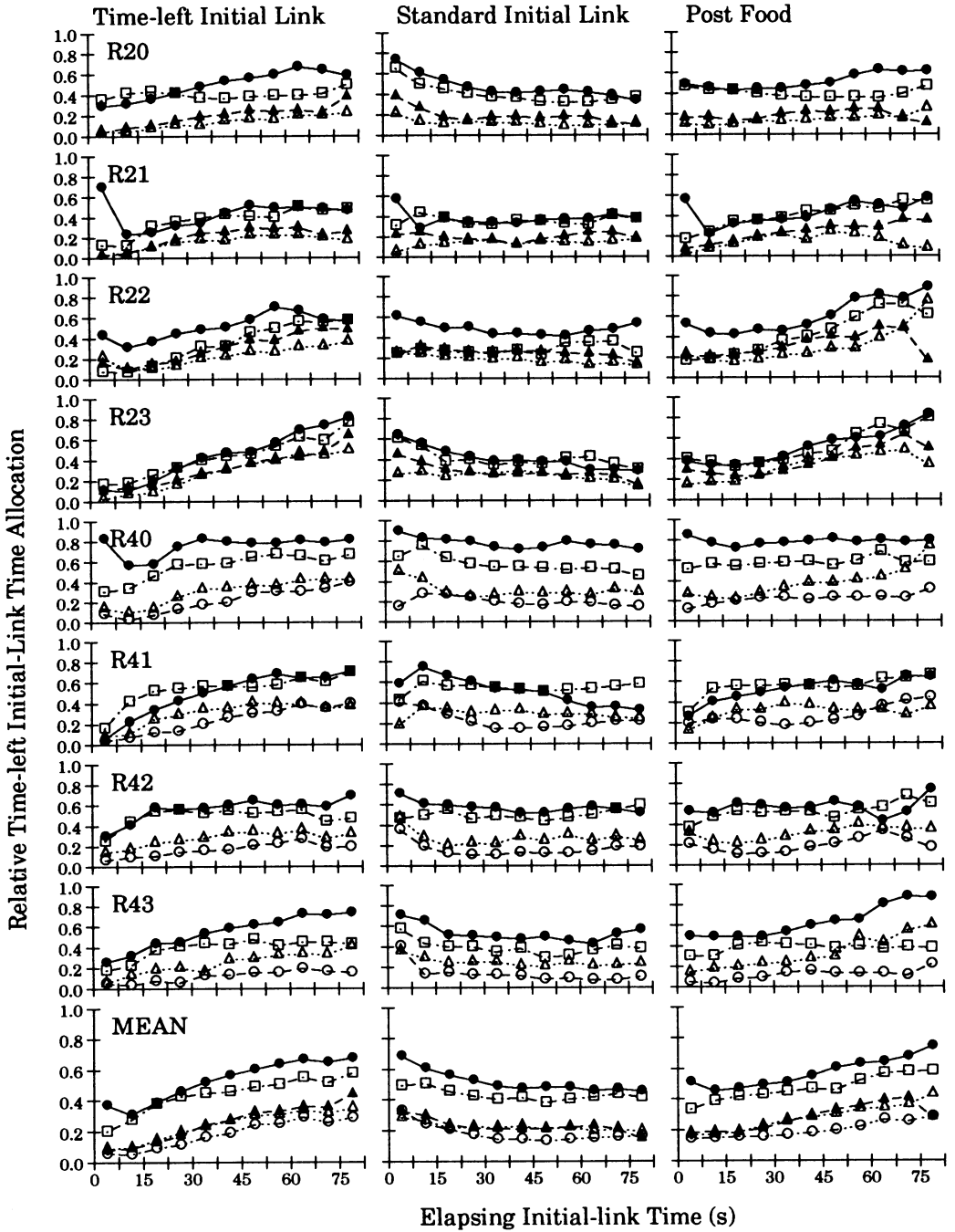

Fig. 9. Relative time-left time allocation as a function of time in the time-left initial link (left column of graphs), time in the standard initial link (center column of graphs), and time since food on either initial link (right column of graphs) for 8 rats responding in a concurrent-chains schedule with a time-left terminal link. The different curves for each rat are described in Figure 8.

### *Relative Time-Left Terminal-Link Entries*

Figure 10 shows the obtained relative time-left terminal-link entries for each rat and each condition plotted as a function of elapsed time in the time-left initial links (left column of graphs), the standard initial links (center column), and over both initial links (right column). The group means are plotted in the bottom graph of each column. Relative time-left terminal-link entries were essentially as programmed. The left and center columns of graphs show the typical relationship between reinforcement probabilities on independent and concurrent VI schedules with arithmetic VI distributions. The probability of a reinforcer on a given schedule is an increasing function of elapsed time on that schedule, whereas the probability of reinforcement on the other VI schedule is independent of the current schedule. Most rats produced orderly deviations from the programmed relative entries for the  $S = C/2 = 45$  s condition, but other deviations from the programmed values tended to be idiosyncratic for the individual rats and conditions. As is typically the case, concurrent-chains schedules ensured good control over the relevant independent variables.

### DISCUSSION

Preference for time-left terminal links, imbedded in concurrent-chains schedules, were orderly functions of elapsing time-left initial-link time. Increasingly shorter terminal-link durations were increasingly preferred in relation to unvarying average standard comparison VI requirements. Disregarding a likely negative recency effect on both levers, preference was an orderly function of elapsing time-left initial-link time but not of elapsing standard initial-link time. Over conditions, shorter standard VI schedules were more preferred throughout the interval than were longer standard schedules. The orderly results within and across conditions show that responses were controlled by the elapsing delay schedule in concurrent chains and encourage the view that preference can be efficiently investigated in the procedure of Experiment 2. How these data relate to the several choice and timing models depends on whether the models are strictly applicable, that is, whether the terms and relationships formalized in the models fully encompass the relationships inherent in the pro-

cedure. The predictions of SET and delay reduction are discussed here, but both were derived in unusual ways.

### *Scalar Expectancy Theory*

The discussion of how SET predicts the data of Experiment 2 is divided into three sections. First, the basic model is presented in the context of choice between two fixed-duration terminal links (i.e., as for the conditions of Experiment 1). Second, predictions are derived for the situation of Experiment 2, in which animals chose between a fixed-duration time-left terminal link and a VI standard terminal link. The third section covers the particulars of how the predictions for Experiment 2 were derived and some shortcomings of the way in which SET has been formulated to deal with choices involving VI terminal links.

*Choices between two fixed-duration terminal links.* According to SET, the procedure of Experiment 2 (like that of Experiment 1) should be treated as a time discrimination problem (Gibbon et al., 1988). An animal must judge, at any time in the elapsing time-left initial link, which of the two terminal links has the shorter expected duration (delay to food if the terminal link is entered). The judgments are made by way of ratio comparisons of estimates of the two durations; the estimates are based on samples from memory distributions laid down over repeated exposures to the durations of the various schedule components in the procedure. When the animal judges that the remaining time on the time-left lever (i.e., the expected time-left terminal-link duration) is less than the duration of the standard terminal link, it will respond on the time-left lever. If, at all initial-link times, both expected terminal links consist of FI schedules (as in Experiment 1) then the predictions are straightforward. The probability that an animal will respond on the time-left lever at some time,  $I$ , in the elapsing initial link depends on the relative sizes of the animal's estimates of the duration of  $S$  ( $x_S$ ) and the duration of  $L$  ( $x_L$ ). To estimate  $S$ , the animal samples its memory for  $S$  durations. To estimate  $L$ , the animal samples its memory for  $C$  durations and subtracts its estimate of the directly appreciated current elapsed time,  $I$  (i.e.,  $x_L = x_C - x_I$ ). Responses should occur on the time-left lever whenever  $x_L/x_S < 1$ , or, equivalently, whenever  $x_C - x_S < x_I$  (Equation 1). In order to make predictions, then, one need



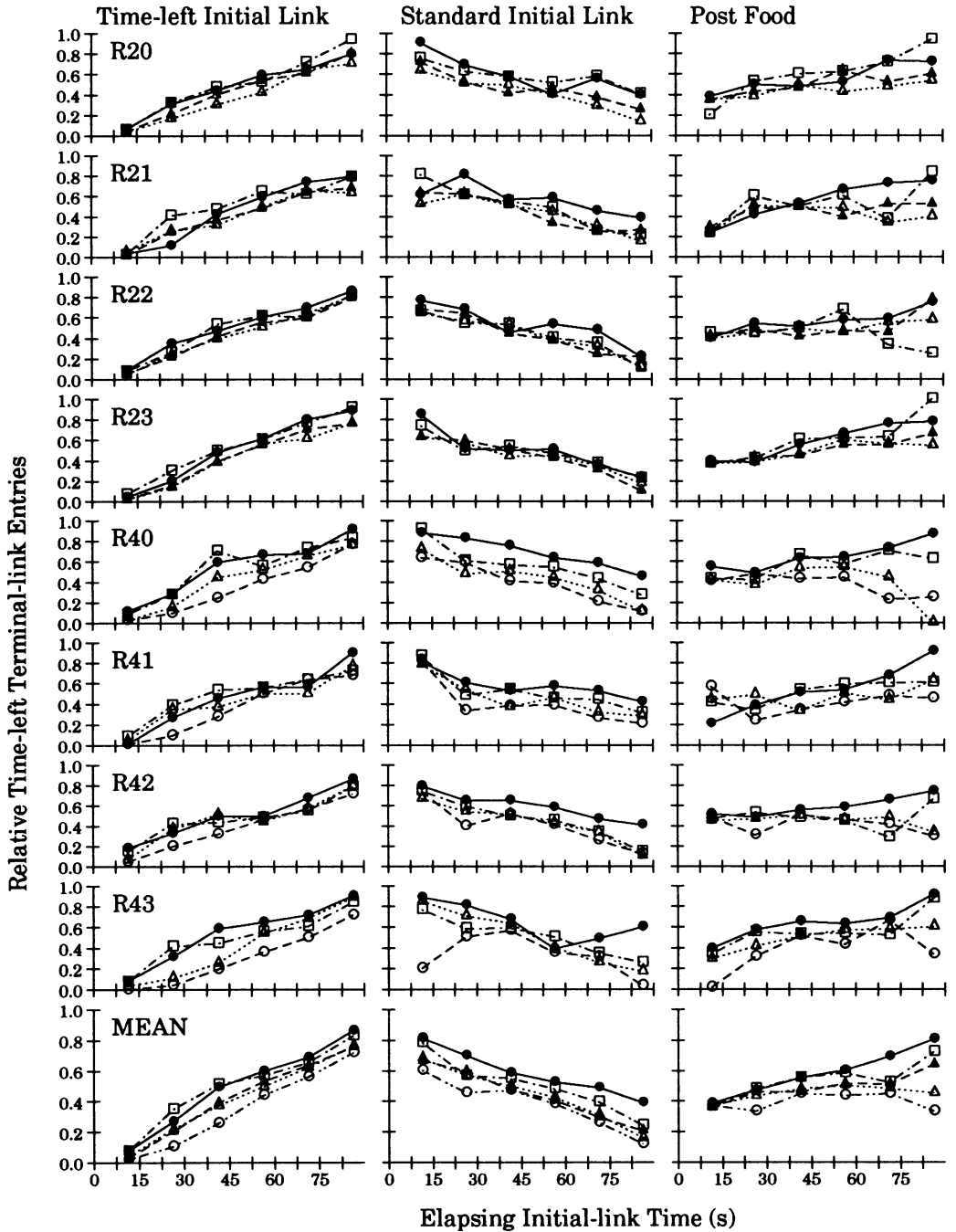

Fig. 10. Relative time-left terminal-link entries as a function of time in the time-left initial link (left column of graphs), time in the standard initial link (center column of graphs), and time since food on either initial link (right column of graphs) for 8 rats responding in a concurrent-chains schedule with a time-left terminal link. The different curves for each rat are described in Figure 8.

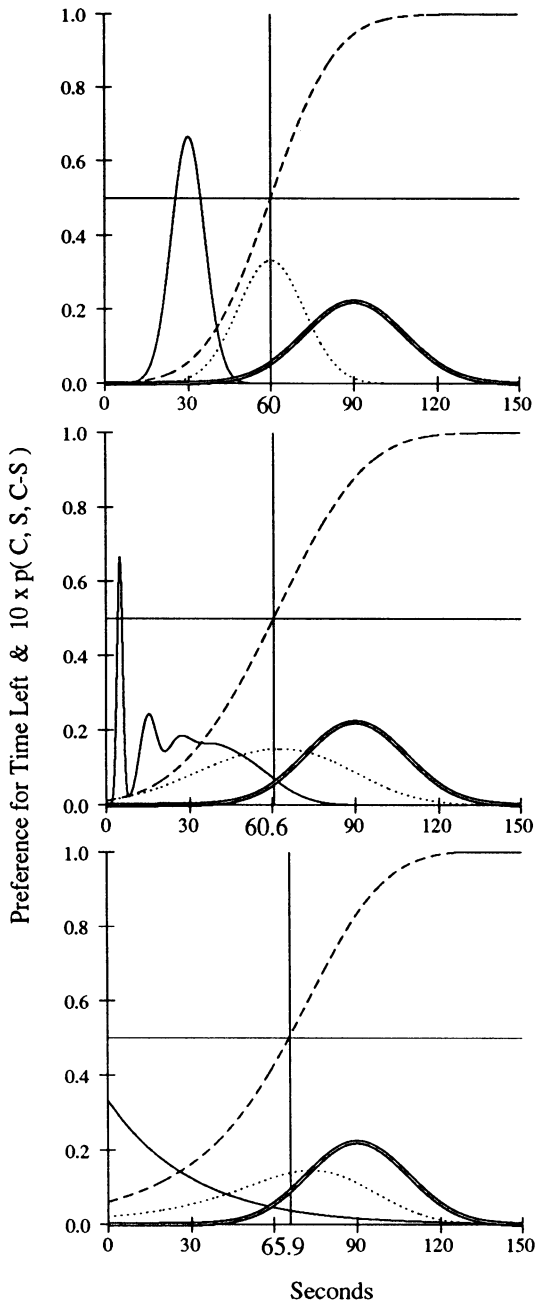

Fig. 11. Theoretical memory distributions (solid, dotted, and double lines) and predicted preference (dashed line), according to scalar expectancy theory, given a time-left procedure with two fixed delays (top graph), one fixed and one variable delay (middle graph), and when a variable delay is approximated by a negative exponential density function (bottom graph). In all cases,  $C = 90$  s,  $S = C/3 = 30$  s. See text for additional description.

only know the theoretical memory distributions for  $C$  and  $S$ , and the probability that a difference,  $x_C - x_S < x_I$ , will occur when one estimate is drawn from each distribution at any time  $I$ . The memory distributions for  $C$  and  $S$  are assumed to be normally distributed with means that are linear in real time and standard deviations that are linear in the mean remembered times (i.e., with a constant coefficient of variation,  $\gamma$ ). The  $C - S$  distribution, being a linear combination of independent random variables, has a mean equal to the difference of the means of the combining distributions and a variance equal to the sum of the variances of the combining distributions. The top panel of Figure 11 shows the theoretical memory distributions for  $S$ ,  $C$ , and their linear combination,  $C - S$ , when  $C$  equals 90 s and  $S$  is an FI schedule equal to  $C/3 = 30$  s ( $\gamma = 0.2$ ), all as a function of elapsed initial-link time. The probability of a time-left response at time  $I$  is the integral from minus infinity to  $I$  of the  $C - S$  distribution. (Gibbon & Church, 1981, Section 1 of the Appendix, provide a detailed example of finding the cumulative distribution function.) The dashed line shows the resulting probability of a time-left response as a function of elapsed initial-link time.

*Choices between fixed and variable terminal-link durations.* Consider, now, the procedure of Experiment 2, in which the standard terminal link is a VI schedule. Estimates for  $C$  are based on a sample from the gaussian distribution of memories for the fixed duration,  $C$ . Estimates for  $L$  are based on the difference between  $x_I$  and a sample from the gaussian distribution of memories for  $C$ . The duration of  $S$ , however, varies over encounters with the standard terminal link, and so the memory for  $S$  is not expected to be a gaussian distribution centered over  $S$ . In order to accommodate memory distributions for variable-duration times, Gibbon et al. (1988) made the simple assumption that the animal tries to remember each of the intervals constituting the VI distribution; the resulting overall distribution of memories for  $S$  is the simple mixture of the several constituent gaussian distributions. (If, for example, six intervals constitute the VI distribution, then each contributes one sixth of its area to the resulting probability density function.) The middle graph in Figure 11 shows the theoretical memory distributions for

$C = 90$  s,  $S = C/3 = 30$  s (the mixture of six gaussian distributions based on the intervals constituting the terminal-link VI), and  $C - S$  when gamma equals 0.2. The dashed line shows the cumulative distribution function of the  $C - S$  probability density function (or, equivalently, the probability of a time-left response) as a function of elapsing initial-link time on the time-left lever. (See the next section for a discussion of how the  $C - S$  density and distribution functions were generated.)

The top panel in Figure 12 shows the predictions of SET, derived in the same way, for all of the conditions of Experiment 2. These predictions should be compared with the data in the bottom left graph of Figure 8. The data are not well predicted by the theoretical functions. The predictions could be adjusted for bias, of course, so that the indifference times in the predictions and the data correspond exactly. More troublesome is the fact that the shapes of the theoretical functions correspond poorly to the data. The theoretical distribution functions are positively accelerated from 0 s to the indifference times; the data are negatively accelerated throughout the time-left initial link. Why SET should fail to predict preference in the procedure of Experiment 2 is unclear. One possibility is that the occasional interruptions of the time-left initial link by irrelevant presentations of the standard terminal link either make time discriminations generally more difficult in the procedure or change the way in which time is discriminated. It will be shown in the next section that different values for gamma do not improve the predictions or substantially change the qualitative shape of the predicted functions. With respect to the second point, it has been assumed so far that animals remember the time-left cycle duration as if it were not occasionally interrupted by presentations of the standard terminal link; in information-processing terms, the accumulator for the time-left cycle duration is switched off during the standard terminal link and then switched on again, without resetting, when the initial links are entered again (cf. Roberts, 1981). The predictions would not improve in any meaningful way, however, if it were assumed that the relevant time-left cycle duration included the time spent in the standard terminal link. The major difference, were that the case, would be in the theoretical memory distribution for the cycle duration. In that case,

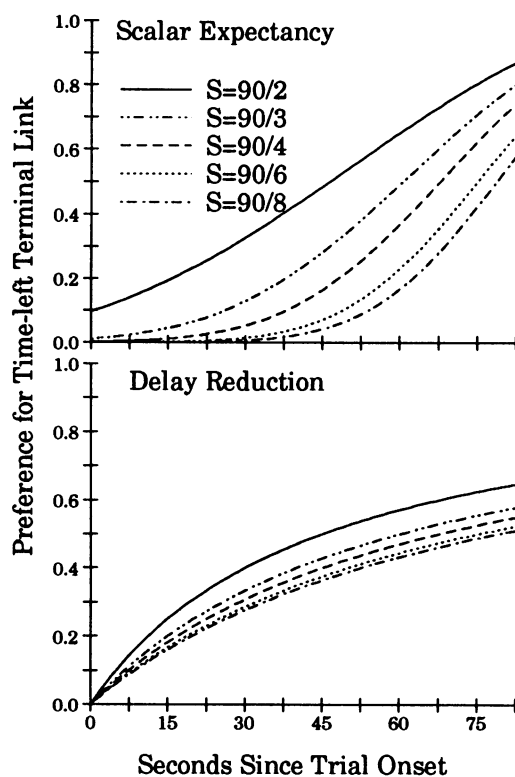

Fig. 12. Predictions of scalar expectancy theory (Gibbon et al., 1988) and delay reduction (Squires & Fantino, 1971) for concurrent chains with a time-left terminal link in one of the component chain schedules. The predictions are for the data in the bottom left graph of Figure 8.

the true cycle would be variable in duration,  $C + S$  s on the average, and made up of six constituent intervals, each equal to  $C$  plus one of the six intervals making up the standard terminal-link VI schedule. The resulting distribution functions would be shallower in slope but still positively accelerated from 0 s to the indifference point—unlike the data, which are negatively accelerated throughout the range of initial-link times.

*SET and memories for variable delays.* It is beyond the scope of this paper to consider the full theoretical structure that underlies SET as a model of choice and animal timing (see Gibbon, 1977; Gibbon & Church, 1981; Gibbon et al., 1988; for detailed accounts). The analysis of Experiment 2, however, required the predictions of SET for choice between VI schedules and FI schedules, and these require some discussion. Notice that the SET predictions in Figure 12 are at odds with the asser-

tion of Gibbon et al. that SET predicts substantial preference for VI schedules over FI schedules with the same mean durations. The function for  $S = C/3 = 30$  s, for instance, predicts that animals will be indifferent to an FI 29.4-s time-left terminal link and a VI 30-s standard terminal link (indifference at  $I = 60.6$  s). According to Gibbon et al., a VI schedule should be judged equivalent to a much shorter FI schedule, with the precise value depending on timing sensitivity. The accounts conflict because the preference functions in the present paper were not made as suggested by Gibbon et al.

According to SET, the theoretical density function of memories for variable-duration times is the simple mixture of the scalar estimates for the individual fixed times making up the variable distribution (Gibbon, 1977; Gibbon et al., 1988). Because it is very difficult to calculate the predictions of SET when the underlying memory distributions are mixtures such as these, Gibbon et al. settled on an approximate solution. They argued that variable distributions could be approximated by negative exponential density functions with the same means. The approximations were specifically intended for constant probability VI distributions, but were said to be sufficiently general for arithmetic distributions as well. I shall argue here that negative exponential approximations for variable schedules are not satisfactory. I shall argue, too, that the apparent success of SET in predicting preference for variable over fixed schedules (Experiment 2 notwithstanding) needs to be reevaluated. In the present paper, the density functions for variable distributions were generated as the simple mixtures of the VI distributions without further simplification. The probability density functions for the  $C - S$  probabilities were then derived by performing every possible subtraction, in 0.25-s resolution, of the  $C$  and  $S$  distributions and then calculating the probability of observing the resulting differences. If  $C$  and  $S$  are independent random variables with probability density functions  $f_C(c)$  and  $f_S(s)$ , and if  $D = C - S$ , then

$$f_D(d) = \int_{-\infty}^{\infty} f_C(x) \cdot f_S(x - d) dx.$$

The function  $f_D(d)$  gives the probability of observing a given difference  $x_C - x_S = d$  when

one sample each is drawn from the  $C$  and  $S$  distributions. For the analyses reported here, the probabilities were calculated at discrete 0.25-s intervals and the areas centered over each of those intervals were approximated by multiplying the probability by .25. The probability that  $x_C - x_S < x_I$  (i.e., the probability of a time-left response at any time  $I$ ; see Equation 1) is the integral of  $f_D(d)$  from negative infinity to  $I$ . Accordingly, the cumulative distribution functions were calculated by accumulating the areas of successive 0.25-s bins of the  $C - S$  density functions.

The middle and bottom graphs of Figure 11 show how the predictions derived from the method reported here compare with the less precise negative exponential approximations of Gibbon et al. (1988). The middle graph, to repeat, shows the theoretical memory distributions, and the predicted preference for the time-left lever, for the procedure of Experiment 2 when  $C = 90$  s,  $S = C/2 = 30$  s, and  $\gamma = 0.2$ . The bottom graph shows the same functions when the mixture is approximated by a negative exponential density function with an expected value of 30. Note the discrepancy between the two sets of predictions. In the middle graph, the two terminal links should be judged to be equivalent at  $I = 60.6$  s; in the bottom, indifference occurs at  $I = 65$  s. The critical feature is that, contrary to previous descriptions, true theoretical indifference between the fixed-duration time-left terminal link and the variable-duration standard terminal link occurs when their mean values are approximately equal.

Figure 13 shows the predictions of SET (preference for the time-left initial link as a function of elapsed time-left initial-link time) for the same conditions ( $C = 90$  s,  $S = C/3 = 30$  s,  $S$  variable) calculated in four different ways. The left column of graphs shows, top to bottom, the predictions when  $S$  consists of an arithmetic VI schedule, a constant probability VI schedule composed of six intervals determined according to Fleshler and Hoffman (1962), a negative exponential density function with the same mean, and Gibbon et al.'s Equation 7 for preference involving fixed and variable terminal links. The different curves in each graph are for different values of  $\gamma$ : 0.05 (solid line), 0.2 (dotted line), and 0.8 (dashed line). (For the bottom graph only, the double line is for  $\gamma = 0.4$ .) Each

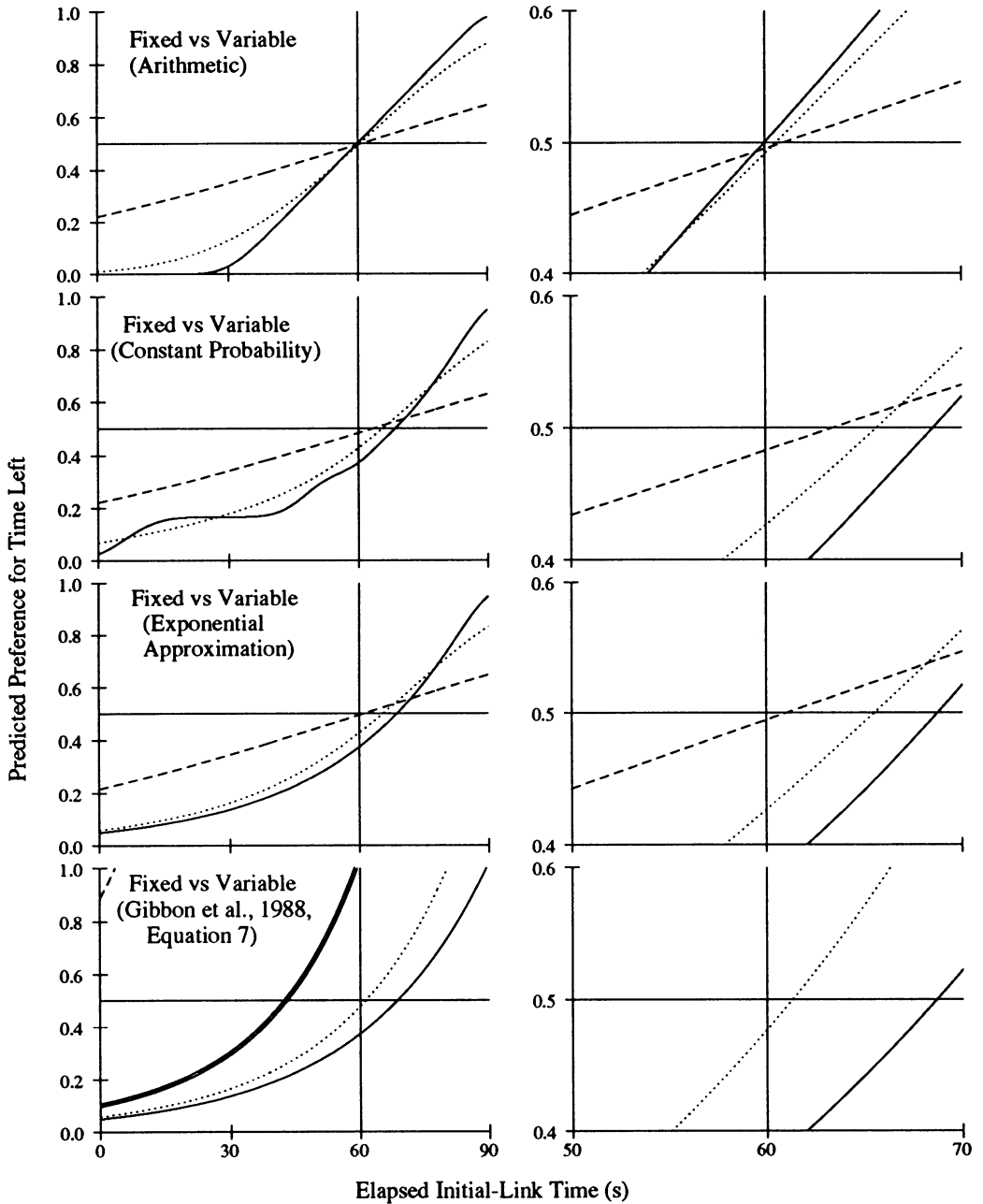

Fig. 13. Predicted preference, according to scalar expectancy theory, given a time-left procedure with  $C = 90$  s,  $S = C/3 = 30$  s, and gamma equal to 0.05 (solid line), 0.2 (dotted line), 0.8 (dashed line) or 0.4 (double line). Different rows of graphs show the predictions for different types of standard-lever VI distributions or are based on different mathematical treatments of the predictions. Graphs in the right column are expanded views of portions of the graphs in the left column.

graph in the right column shows a small portion of the graph to its left enlarged to show how gamma affects preference around the point where the schedules have equal mean delays

( $I = 60$  s). Three features of the graphs are of interest. First, the negative exponential approximation agrees well with the actual predictions of SET when the standard VI sched-

ule is a constant probability VI but not with the predictions for arithmetic VI schedules (except when timing precision is very poor). Second, predicted preference for a VI schedule over an FI schedule with the same mean delay becomes greater with greater timing sensitivity only for constant probability VIs, when VI schedules are approximated by negative exponentials, and according to Gibbon et al.'s Equation 7. On the contrary, SET predicts that arithmetic VI schedules should be judged to be increasingly similar to FI schedules with the same mean as timing sensitivity increases. The third point is trivial, in a sense, but requires discussion nevertheless. Gibbon et al.'s Equation 7, in the form suggested for predicting preference in the time-left procedure, grows increasingly inaccurate and counter to fact as  $\gamma$  grows large. Even if one assumes that the negative exponential approximations are valid, the equation is of limited use. When  $\gamma$  becomes moderately large (say, around 0.3), their Equation 7 (but not SET) predicts that animals will prefer fixed-duration time-left terminal links over variable-duration standard delays even when the variable delay has a smaller mean value. This is counter to fact and not otherwise representative of the predictions of SET utilizing negative exponential approximations of variable delays.

The conclusions are troublesome. It is true that the negative exponential approximation for variable schedules results in the prediction that VI schedules will be greatly preferred to FI schedules with the same mean. It is not true, however, that this prediction follows from the current assumptions of SET, at least not for arithmetic VI distributions. The issue, though, is not what approximation might be appropriate for arithmetic distributions. The implication is that the assumption of a simple mixture of scalar estimates of the constituent intervals of a VI distribution is not likely to be generally successful. Because there is, in fact, substantial preference for arithmetic VI schedules over FI schedules with the same mean (e.g., Davison, 1972; Killeen, 1968), SET must accommodate this fact and incorporate a conception of memories for variable distributions that successfully predicts the finding. It is not enough, even though true, that the assumption of simple mixtures was successful for constant probability VI schedules; not unless the same memory processes result in reasonable predictions for arithmetic schedules.

A final point about the way in which SET is applied to choice situations is that several different assumptions have been made about the variance associated with discriminating the elapsed time in time-left initial links. Gibbon and Church (1981) assumed that there was negligible variance associated with the discrimination of elapsed time. Gibbon et al. (1988) made different assumptions depending on whether animals were choosing between two fixed delays (Gibbon et al.'s Equations 3 and 4) or between a fixed and variable delay (Gibbon et al.'s Equation 7). The procedure reported here for calculating the predictions of SET implies the assumption of Gibbon and Church: that there is no variance associated with the discrimination of elapsed time. The predictions of the model would not improve if it were assumed that the total variance of the time discriminations increased as time elapsed in the initial link. The predicted indifference points would not be affected at all. The slopes of the functions would be shallower, though, and more so at longer initial-link times.

#### *Delay Reduction*

The various choice and conditioned reinforcement models, although explicitly developed in the context of concurrent chains, are still not unambiguously applied to this procedure; none of them has been elaborated to encompass temporal discriminations as such (although see Killeen & Fetterman, 1988). Instead, they predict choice as a function of the reinforcing value of the terminal links (variously conceived) and the frequencies of conditioned or primary reinforcement. According to the delay-reduction model (Squires & Fantino, 1971), the reinforcing value of a food-paired stimulus is determined by the degree of temporal association between the stimulus and food. The smaller the percentage of the average overall delay to food occupied by a stimulus, the greater its reinforcing strength. Therefore, the predicted preference at any time in the elapsing time-left initial link should be the relative sizes of the two delay percentages so calculated. This seem to be an inappropriate model for Experiment 2, however, because it predicts no special role for the temporal differentiation of the relative terminal-link delays in the 90-s time-left cycle duration. The bottom graph of Figure 11, therefore, shows the predictions of the delay-reduction model calculated in an unorthodox manner. The ex-

pected time-left and standard terminal-link delays at each time in the elapsing initial link were expressed as percentages of  $C$  (90 s) rather than as percentages of the overall delay to food when calculating the conditioned reinforcement values. The predictions of delay reduction, so modified, are qualitatively in good agreement with the preference functions from Experiment 2, predicting that preference will be monotonically increasing, concave down, functions of elapsing time-left initial link, with higher asymptotes for longer average standard terminal links. (In keeping with the form of delay reduction discussed by Luco, 1990, the conditioned reinforcement terms were multiplied by the expected rates of terminal-link entries, not by the primary reinforcement rates.)

### GENERAL DISCUSSION

Gibbon et al. (1988) argued that the elapsing-delay feature of the time-left procedure "encourages subjects to base choice on a direct appreciation of the upcoming delays to food" (p. 105) and thereby avoids the secondary (conditioned reinforcement) effects that occur in concurrent chains. Their conclusions were apparently based, in part, on the fact that SET made more accurate predictions of the data that resulted from the procedure than did a number of traditional models of choice and conditioned reinforcement. Experiment 1, however, showed that the data of the time-left procedure can be predicted without making any assumptions at all about animal timing. Because the procedure places the temporal parameters of the component schedules directly under the control of responses, any model that assumes that behavior is sensitive to relative rates of reinforcement must necessarily make predictions that correspond to the data produced by the procedure. The procedure of Experiment 2, designed to overcome the problems of the time-left procedure, provided little support for Gibbon et al.'s (1988) assertion that elapsing delays bring behavior uniquely under the control of the temporal delays to food. Especially difficult to reconcile with this view is the fact that the relative time-left responses in Figure 8 approached asymptotes considerably below 1.0. The predictions of SET require that preference eventually approach 1.0 (if the time axis were extended sufficiently; see Figure 11).

It is difficult to judge whether the procedure

of Experiment 2 should be considered an appropriate context for comparing the predictions of SET and other models of choice. Gibbon et al. (1988) stated explicitly that SET was not yet elaborated for the complexities of concurrent chains. It is not clear, though, exactly what features of concurrent chains lie outside the purview of SET, or in what way the time-left procedure was originally presumed to avoid the relevant complexities. The assumption underlying Experiment 2, suggested by Gibbon et al., was that the elapsing-delay feature, as such, might be the relevant distinction between the two procedures. Had SET made accurate predictions, then the question would be answered. That it did not means that no simple conclusions can be drawn. On the one hand, the data could be viewed as having demonstrated additional limits to the generality of SET as a general model of choice, or as having demonstrated that it is less successful than other models. Less interesting, but equally plausible, would be the assumption that SET was already well known to be unable to account for such data—that some other feature of concurrent chains, some feature retained in the procedure of Experiment 2, makes them unsuitable for assessing the predictions of SET.

Either way, the combined results of the two experiments weaken the claims of SET. The claims are weakened primarily because many of the conclusions drawn from studies that utilize the time-left procedure of Experiment 1 will have to be reconsidered. There are too many alternative explanations for the procedure's data if all the extant choice models, all unelaborated for time-discrimination problems, predict the data as well as SET. SET's claims are weakened, also, inasmuch as the model's account of preference for variable delays may be less successful than previously supposed. At the very least, those successes must be considered tentative until a single set of assumptions provides reasonable predictions for both arithmetic and constant probability VI distributions.

The predictions of the delay-reduction model for Experiment 2 were qualitatively in good agreement with the data, but the model's success may have been purchased at a price. Delay reduction was among the first formulations of stimulus conditioning, albeit in the context of conditioned reinforcement, that made the simple assumption that conditioning depends on

a temporal correlation between a neutral stimulus and an unconditioned stimulus (Fantino, 1969). The modified model that produced the predictions shown in Figure 12 cannot strictly be said to share that assumption. According to Fantino, the conditioned reinforcing value of a food-paired stimulus is jointly determined by the duration of the stimulus and the temporal context provided by the overall average expected time to primary reinforcement in the conditioning situation. In a sense, the average interreinforcement interval provides a standard by which stimulus durations are measured. The smaller the expected delay to food in the presence of the stimulus relative to the overall average time to reinforcement, the more potent is the stimulus as a conditioned reinforcer.

In the modified model, the time-left cycle duration,  $C$ , provides the context in which stimulus durations are evaluated. The modification departs from the usual formulation of the delay-reduction model, most importantly in abandoning the assumption that the average interreinforcement interval plays a psychologically primitive role in stimulus conditioning. In fact, is not clear whether the modification should be considered to be a special application of Fantino's (1969) model or an empirical model loosely based on delay reduction. According to Fantino, the reinforcing efficacy of a food-paired stimulus "is determined by the degree of reduction in the expected time to primary reinforcement" (p. 730) signaled by the onset of the stimulus. Considered as an extension of delay reduction, the modified model implies the additional assumption that the contextual "expected time to primary reinforcement" must be understood to mean different things in different experimental situations. Perhaps time-discrimination procedures, by explicitly programming de facto temporal contexts for stimulus durations or reinforcement probabilities, result in control by different temporal aspects of the procedure. When the programmed consequences of behavior are differentiated over a specific time interval, that interval (instead of the average interreinforcement interval) may acquire control as the temporal context for stimulus conditioning. At present, however, the modified version of the delay-reduction model is best justified by the correspondence between the data and the predictions. Only if similar modifications were

found to be necessary for related procedures would there be much point in speculating about the model's implications.

Finally, the combined results of Experiments 1 and 2 did not support the view that the elapsing-delay feature of the time-left procedure eliminates or suppresses the normal conditioned reinforcement inherent in the onsets of food-associated stimuli. It was too much, perhaps, to hope that time alone would control choice in the time-left procedure. There is much evidence from related procedures that food-associated stimuli have reinforcing effects not attributable to their roles as signals of temporal delays to primary reinforcement. For example, Williams and Dunn (1991) reported a series of conditions wherein pigeons responded on a two-alternative concurrent-chains schedule. The two initial-link schedules arranged the same shared stimulus and terminal-link schedule of food presentation. Yet another schedule conjointly arranged additional presentations of the same stimulus, but without food. The absolute frequency of the additionally scheduled terminal links was held constant across conditions, but the relative frequency assigned to one or the other initial-link key was varied. Preference for a given choice alternative varied directly with the overall frequency of stimulus presentations, even though higher frequencies were uniformly associated with longer average delays. Williams and Dunn argued that models of choice that ignore the reinforcing role of terminal-link stimuli, or that ignore the effects of the rates of terminal-link stimuli, are unlikely to have generality. The procedure of Experiment 2 did not address these issues directly, but the results suggest that something other than simple expected times to food controls choices for food-associated stimuli, or, at least, that the timing processes proposed by SET are not wholly sufficient to account for those choices.

## REFERENCES

- Chung, S., & Herrnstein, R. J. (1967). Choice and delay of reinforcement. *Journal of the Experimental Analysis of Behavior*, *10*, 67-74.
- Davison, M. C. (1972). Preference for mixed-interval versus fixed-interval schedules: Number of component intervals. *Journal of the Experimental Analysis of Behavior*, *17*, 169-176.
- Davison, M. C. (1987). The analysis of concurrent-



- chain performance. In M. L. Commons, J. E. Mazur, J. A. Nevin, & H. Rachlin (Eds.), *Quantitative analyses of behavior: Vol. 5. The effect of delay and intervening events on reinforcement value* (pp. 225-241). Hillsdale, NJ: Erlbaum.
- Fantino, E. (1969). Choice and rate of reinforcement. *Journal of the Experimental Analysis of Behavior, 12*, 723-730.
- Fantino, E., & Royalty, P. (1987). A molecular analysis of choice on concurrent chains. *Journal of the Experimental Analysis of Behavior, 48*, 145-159.
- Fleshler, M., & Hoffman, H. S. (1962). A progression for generating variable-interval schedules. *Journal of the Experimental Analysis of Behavior, 5*, 529-530.
- Gibbon, J. (1977). Scalar expectancy theory and Weber's law in animal timing. *Psychological Review, 84*, 279-325.
- Gibbon, J., & Church, R. M. (1981). Time-left: Linear versus logarithmic subjective time. *Journal of Experimental Psychology: Animal Behavior Processes, 7*, 87-108.
- Gibbon, J., Church, R. M., Fairhurst, S., & Kacelnik, A. (1988). Scalar expectancy theory and choice between delayed rewards. *Psychological Review, 95*, 102-114.
- Killeen, P. (1968). On the measurement of reinforcement frequency in the study of preference. *Journal of the Experimental Analysis of Behavior, 11*, 263-269.
- Killeen, P. (1970). Preference for fixed-interval schedules of reinforcement. *Journal of the Experimental Analysis of Behavior, 14*, 127-131.
- Killeen, P. R. (1982). Incentive theory: II. Models for choice. *Journal of the Experimental Analysis of Behavior, 38*, 217-232.
- Killeen, P. R., & Fantino, E. (1990). Unification of models for choice between delayed reinforcers. *Journal of the Experimental Analysis of Behavior, 53*, 189-200.
- Killeen, P. R., & Fetterman, J. G. (1988). A behavioral theory of timing. *Psychological Review, 95*, 274-295.
- Luco, J. E. (1990). Matching, delay-reduction, and maximizing models for choice in concurrent-chains schedules. *Journal of the Experimental Analysis of Behavior, 54*, 53-67.
- Preston, R. A., & Fantino, E. (1991). Conditioned reinforcement value and choice. *Journal of the Experimental Analysis of Behavior, 55*, 155-175.
- Roberts, S. (1981). Isolation of an internal clock. *Journal of Experimental Psychology: Animal Behavior Processes, 7*, 242-268.
- Squires, N., & Fantino, E. (1971). A model of choice in simple concurrent and concurrent-chains schedules. *Journal of the Experimental Analysis of Behavior, 15*, 27-38.
- Vaughan, W., Jr. (1985). Choice: A local analysis. *Journal of the Experimental Analysis of Behavior, 43*, 383-405.
- Williams, B. A., & Dunn, R. (1991). Preference for conditioned reinforcement. *Journal of the Experimental Analysis of Behavior, 55*, 37-46.

Received March 4, 1993

Final acceptance December 8, 1993