

THE FORCE OF CONTRACTION OF THE HUMAN CILIARY MUSCLE DURING ACCOMMODATION

By R. F. FISHER

*From the Department of Visual Science, Institute of Ophthalmology,
Judd Street, London WC1H 9QS*

(Received 16 July 1976)

SUMMARY

1. Apparatus has been designed to alter the shape of the human lens by tensile forces applied to the zonular fibres indirectly through the ciliary body. The changes in dioptric power of the lens for monochromatic sodium light were measured at the same time. Simultaneous serial photography, and direct measurement enabled one to relate a change in shape of the lens to the change in dioptric power. Subsequently, the same lens was isolated and spun around its antero-posterior polar axis and high speed photography recorded its changing profile.

2. By comparing the changes in lens profile due to zonular tension and centrifugal force respectively, the force developed in the zonule for a given change in the shape of the lens could be calculated. Changes in dioptric power associated with those of shape can thus be related directly to the force of contraction of the ciliary muscle necessary to reduce the initial tension of the zonule in the unaccommodated state.

3. The force of contraction of the ciliary muscle as measured by radial force exerted through the zonule and the change in dioptric power of the lens were not linearly related. The relationship is more exactly expressed by the equation

$$D = K_{dr}\sqrt{F_{CB}},$$

where D = amplitude of accommodation in dioptries (m^{-1}), F_{CB} = force of contraction of the ciliary muscle as measured by changes in tension of the zonule (N), K_{dr} = dioptric force coefficient and is constant for a given age ($m^{-1}N^{-\frac{1}{2}} \times 10^{2.5}$). This coefficient is 0.41 at 15 yr and 0.07 at 45 yr of age.

4. In youth for maximum accommodation (10-12 D) the force is approximately 1.0×10^{-2} N while to produce sufficient accommodation for near vision (3.5 D) the force is less than 0.05×10^{-2} N.

5. After the age of 30 yr the force of contraction of the ciliary muscle necessary to produce maximum accommodation rises steadily to about

50 yr of age and thereafter probably falls slightly. At about 50 yr of age the ciliary muscle is some 50 % more powerful than in youth.

6. Even if hypertrophy of the muscle did not occur the amplitude of accommodation would be reduced at the most by only 0.8 D of that observed at the onset of presbyopia.

INTRODUCTION

Estimates of the force of contraction of the ciliary muscle have so far been based on measurements of convergence and the action of drugs on the amplitude of accommodation of the lens. As these methods are necessarily indirect the role of the ciliary muscle during accommodation is still the subject of dispute.

The difference of opinion concerns the relationship between the contractile force of the ciliary muscle and the amount of accommodation produced by it.

Donders (1864) thought that the amount of force required to change accommodation by one dioptré was constant at all ages and presbyopia was due mainly to failure of the ciliary muscle. The opposite view was held by Helmholtz (1855) who supposed that although the power of the ciliary muscle might actually increase with age, the loss of accommodation was due to failure of the lens to change in shape and become more spherical when zonular tension was reduced.

In the past this failure of the lens was thought to be due to a loss of water from the lens substance and the onset of nuclear sclerosis. Fisher & Pettet (1973) showed that there is no loss of water in the presbyopic lens, but only a closer packing of fibres within the ageing lens nucleus which may cause a rise in its Young's modulus of elasticity.

A method of resolving these difficulties is to measure directly the change in the force of contraction of the ciliary muscle which is required to produce a given change in the dioptric power of the human lens at a given age. It is possible to do this on the cadaver eye because although the dead ciliary muscle is no longer contractile its function in life is merely to reduce existing tension. Thus, in the cadaver eye the lens assumes the accommodated state because zonular tension is reduced to zero by the loss of intraocular pressure and the collapse of the globe. In the living eye, there is evidence that zonular tension can be reduced to a low value upon maximal contraction of the ciliary muscle since Hess (1904) observed that during accommodation the lens sinks in the direction of gravity.

If therefore the cadaver lens is restored to its unaccommodated state by traction on the ring of tissue of the ciliary muscle the original tension in the zonule can also be restored. Subsequently the tension may be reduced at

will, corresponding to changes in ciliary muscle contractile force by diminishing the diameter of the ciliary ring, Pl. 1. This paper describes an apparatus to achieve this effect, and with it the following estimations were made:

(i) The amount of ciliary muscle force required to produce a given change in dioptric power of the human lens was determined and the relationship between the force of contraction of the ciliary muscle and the change in dioptric power of a given lens deduced.

(ii) Changes in the dioptric power of lenses of different ages were compared when they were subjected to the same amount of ciliary muscle contractile force.

(iii) The maximum force of contraction of the ciliary muscle at every age was deduced.

METHODS

Materials

Intact eyeballs were obtained from human cadavers not more than 8 h after death. As autolysis develops readily in the ciliary muscle, only very fresh eyes were used, and it was absolutely necessary for the zonular fibres to remain firmly attached to the ciliary muscle if a successful experiment was to be completed.

Dissection of eyeball

The method of dissecting the eyeball is shown in Text-fig. 1 and the procedure was as follows.

(i) After the eyeball had been opened with a scalpel the cornea was cut around the limbus and removed.

(ii) The exposed anterior surface of the eye was then flooded and kept moist with normal saline.

(iii) A cyclodialysis spatula was introduced into the eye at the limbus and the ciliary body gently detached from its insertion in the sclera.

(iv) After the entire ring of ciliary muscle had been separated the spatula was moved down into the space between the sclera and choroid, great care being taken to avoid damage to the inner coats of the eyeball. If perforation occurred the specimen was discarded.

(v) A radial cut made in the sclera was followed by a circumferential cut around the globe midway between the equator of the globe and the corneal limbus.

(vi) The scleral strip was then removed to expose the outer surface of the ciliary body and choroid.

Attachment of ciliary body to fixation jaws of chuck

Text-fig. 1 shows that the fixation jaws of the chuck were initially held in the correct position by a specimen holder ring. The inner surface of each jaw was rendered concave by careful machining to fit the sagittal radius of curvature of the outer surface of the ciliary body, while for any given experiment the diameter of the assembled jaws forming a ring in the holder was adjusted to fit the coronal diameter of the ciliary body.

The specimen holder ring was suspended by three fine wire helical springs (not shown) so as to avoid distortion of the choroid by pressure of the jaws. Next, the

dissected globe was placed in a cup of modelling clay (plasticine) (not shown) under the suspended jaws. The surface of the fixation jaws of the chuck were smeared with cyanoacrylate adhesive (Eastman 910), and lowered on to the moist surface of the ciliary body. Firm and uniform adhesion occurred in less than 2 min.

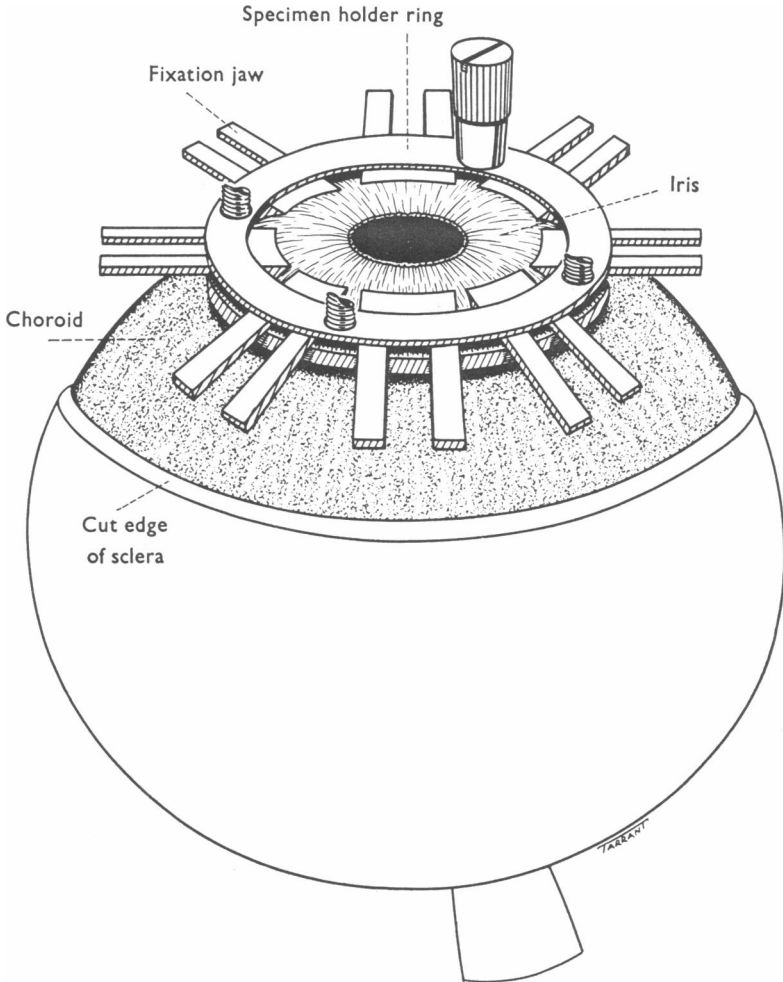

Text-fig. 1. Method of dissecting the eyeball and attachment of fixation jaws to ciliary body.

Separation of ciliary muscle from globe

After this, very slight traction was produced by raising the stand (not shown) to which the springs supporting the chuck and specimen were attached. Next, the choroid was cut round with fine microscissors at the level of its fusion with the outer edge of the ciliary body. A pair of large blunt pointed curved scissors was next introduced between the inner surface of the globe and the back of the lens. Gentle

cutting movements were then made to separate any attachments of the vitreous body from the back of the lens.

The specimen which now consisted of lens, intact zonule, iris and ciliary body could then be removed intact from the globe and placed in a flat glass dish filled with normal saline. As the jaws were firmly fixed to the specimen and clamped within the specimen holder ring no distortion of the ciliary muscle occurred and the specimen was easy to handle.

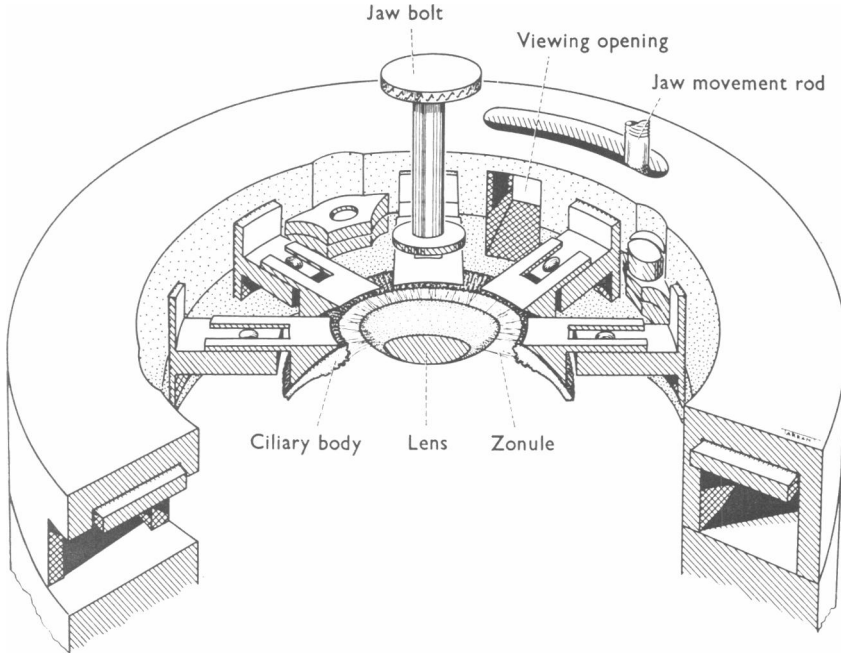

Text-fig. 2. Sectional drawing of apparatus for stressing the lens through ciliary body and zonule.

Examination of specimen and attachment to stressing apparatus

While the specimen was in the flat glass dish and covered with normal saline the iris was carefully removed by cutting it around at the periphery where it fused with the outer surface of the ciliary body. This made it possible to examine the entire surface of the lens and zonular fibres under the high power of a dissecting microscope. If any of the zonular fibres was seen to be ruptured or the lens surface appeared damaged the specimen was discarded.

The specimen supported by its holding ring was next bolted to the stressing apparatus shown in Text-fig. 2. This apparatus moved the jaws radially when the jaw movement rod was actuated.

Once the jaw bolts had been bolted into position the holding ring was removed and the specimen was ready to be examined. Note that as the ciliary body was only stressed to its unaccommodated state no radial cut was needed in the specimen between adjacent jaws to enable one to enlarge the ciliary muscle ring. Indeed, there was no impediment to radial jaw movement under these physiological conditions.

General layout of apparatus for determining dioptric power of the lens

The layout of the apparatus which was designed to measure simultaneously the change in radius of the ciliary ring, the strain produced in the lens by zonular tension, and the change in dioptric power of the lens is shown in Text-fig. 3.

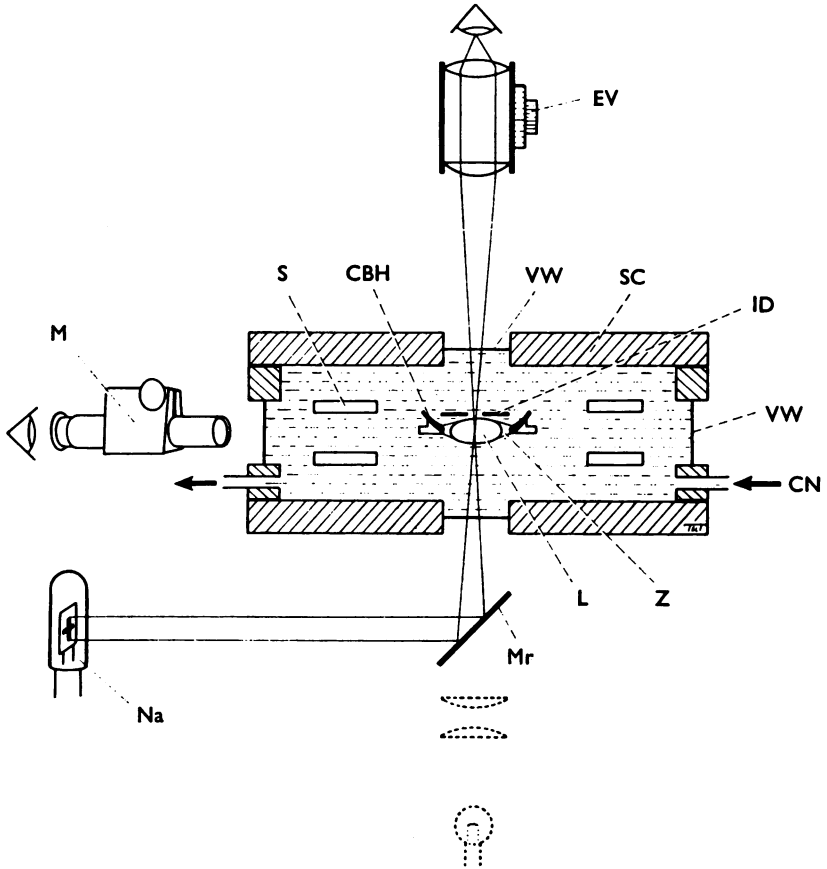

Text-fig. 3. Layout of apparatus for measuring the dioptric power and changes in shape of the lens. EV, eyepiece vernier; S, ring of stressing apparatus (see Text-fig. 2); CBH, ciliary muscle and jaw holder; VW, viewing window; SC, saline filled chamber; CN, saline circulating ports; Z, zonule; L, lens; M, microscope; Mr, movable mirror; Na, sodium lamp; ID, artificial iris diaphragm (see text for further details).

(a) *Measurement of the radius of the ciliary ring.* The measurement of changes in radial movement of the jaws of the stressing apparatus (Text-fig. 2) are made by means of a vernier (not shown) engraved on the outer surface of the stressing ring. During manufacture each of the eight jaws was checked and its radial movement individually calibrated; none showed a difference from the mean of more than 0.02 mm in 1.2 mm movement. The vernier could be read to 0.01 mm of radial movement.

(b) *Measurement of lens strain and movement.* The anterior-posterior sagittal thickness of the lens was measured by means of the microscope (Text-fig. 3) focused successively on the upper and lower poles of the lens as seen through the viewing window. The dimensions of the profile of the lens were also measured and checked photographically (see next section). The movement of this travelling microscope could be read to 0.01 mm. Very small translational movements of the entire lens also occurred as zonular tension became very low due to the combined effect of gravity and decreasing zonular tension. This effect was cancelled in measurements of lenticular thickness.

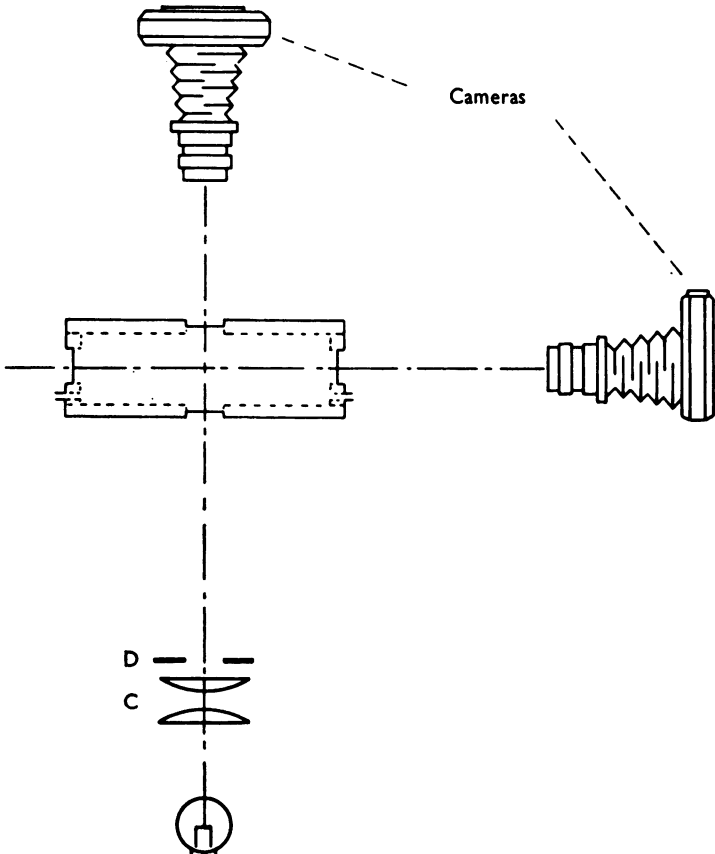

Text-fig. 4. Layout of apparatus for photographing changes of lens profile and diameter. D, diaphragm; C, Condenser.

(c) *Measurement of the dioptric power of the lens.* A sodium lamp was used for the measurement of the dioptric power of the lens.

The human lens was masked by a metal disc with a 4.0 mm diameter metal aperture at its centre to simulate an iris of fixed diameter, and the lens acted as a variable focus convex lens immersed in normal saline. The real image it produced was magnified and examined by the aid of an eyepiece as shown in Text-fig. 3. Any

changes in the focal length of the human lens necessitated a movement of the eyepiece which was measured by a vernier scale reading to 0.01 mm.

The image formed by the fresh human lens was so good that repeated estimates of the dioptric power of the system varied maximally from any one reading by only 0.2 D.

Layout of apparatus for photographing changes in the profile and diameter of the lens

Text-fig. 4 shows the layout for photographing the changes in shape of the lens. Two cameras were employed which could be used simultaneously for photographing the lens under a given zonular stress. A point source tungsten lamp was used, the intensity and field of illumination being adjusted by means of a diaphragm and convex lens.

To avoid complicated corrections due to the lens being totally immersed in saline, a template of known dimensions was placed just above it and included in the pictures. This enabled one to read the scale of the photographs.

PROCEDURE

(a) Measurement of the properties of the lens when subjected to zonular tension

The entire specimen together with the stressing ring (Text-fig. 2) was placed in the cell made from perspex with windows of optical glass (Text-fig. 3). Warm saline was then circulated through the cell by a pump (not shown) and the temperature kept at $37 \pm 1^\circ \text{C}$. A thermometer (not shown) was included in the body of the cell to ensure that temperature remained constant throughout the experiment. The lens was placed with its posterior pole uppermost so that the weight of the lens would have a restraining influence on any backward movement. It was thought that this would best mimic the action of the anterior face of the vitreous which was present *in vivo*. First, the ciliary ring was released by closing the jaws of the chuck so that minimal zonular tension caused by gravity acted on the lens. The force of gravity (5–6 dyn) was due to the weight of the lens in saline.

A clear image of the target was obtained, and the dioptric power of the system measured three times by the image being focused and refocused and the position of the eyepiece measured each time. The mean of the three measurements was taken as the dioptric power of the lens. The distance from the back of the lens to the real image was also measured with the travelling microscope. In order to measure the amplitude of accommodation it is necessary to know the change in dioptric power of the lens. This was obtained by measuring differences in the back vertex power of the human lens under differing degrees of zonular tension, allowance being made for any difference in position of the lens during the experiment.

After each measurement of dioptric power, the polar thickness of the lens and the diameter of ciliary ring was also measured. Then, the ring diameter was increased and a further set of readings taken.

Text-fig. 5 shows typical curves for the decrease in dioptric power of the lens plotted against changes in the radius of the ciliary ring. In a successful experiment a sigmoid curve was produced with no evidence of strain fatigue in the specimen. A point was reached when a further increase in ciliary ring radius made little change in the dioptric power and the lens was then assumed to be in the unaccommodated state. In older lenses after an initial change in dioptric power increased extension of the ciliary ring had little effect (Text-fig. 5). Indeed, from the shape of the curves obtained an estimate of the maximum radius of the ciliary ring varied little from lens to lens. Thereafter, the radius of the ciliary ring was successively reduced with

measurements of dioptric power and lens dimensions recorded at each interval. Finally, the initial and reduced position of the ciliary ring was reached and there was no further change in dioptric power. The dimensions of the lens were again measured and if it had not returned to its original state within the limit of experimental error (± 0.02 mm) the experiment was abandoned.

If the experiment was successful, it was repeated with the same lens but the layout was changed for photography (Text-fig. 4). Two photographs of the lens were taken for each ciliary ring radius used in the first experiment.

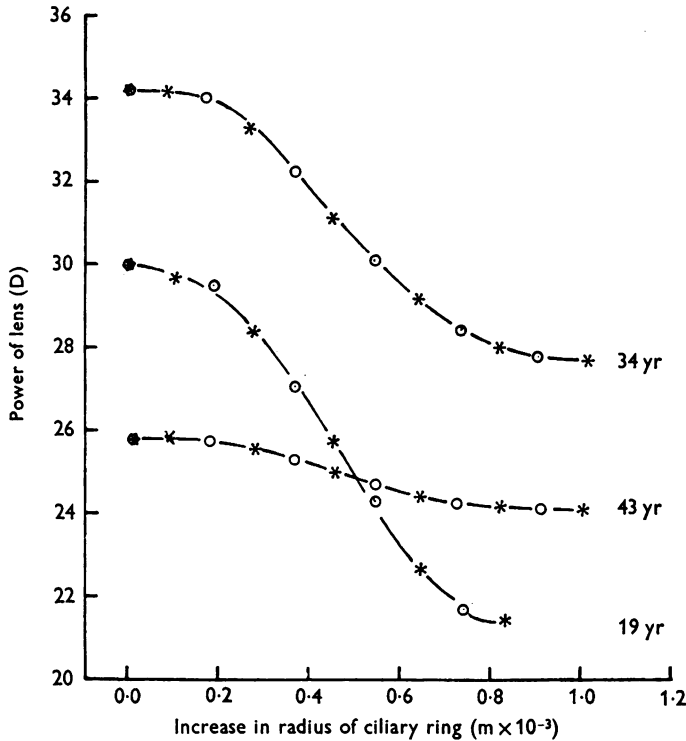

Text-fig. 5. Typical dioptric power/ciliary ring strain curves of human lenses. Note: 0.0 radius of ciliary ring corresponds to the unaccommodated state of the lens. *, increase in radius; O, decrease in radius.

(b) Measurements of the shape of the spinning lens

After measurements had been completed on the intact lens, zonule, and ciliary body, the zonular fibres were carefully cut after the specimen which remained immersed in normal saline had been removed from the cell (Text-fig. 3). This was done with the aid of microscissors under a dissecting microscope. The isolated lens, following a further immersion in saline at 37° C, was then spun around its antero-posterior polar axis in air at varying speeds (Fisher, 1971). The relationship between equal deformations of the lens produced by zonular tension or centrifugal force was used to relate the speed of rotation to a change in dioptric power as follows.

(i) An initial graph (Text-fig. 6A) was drawn showing dioptric power plotted

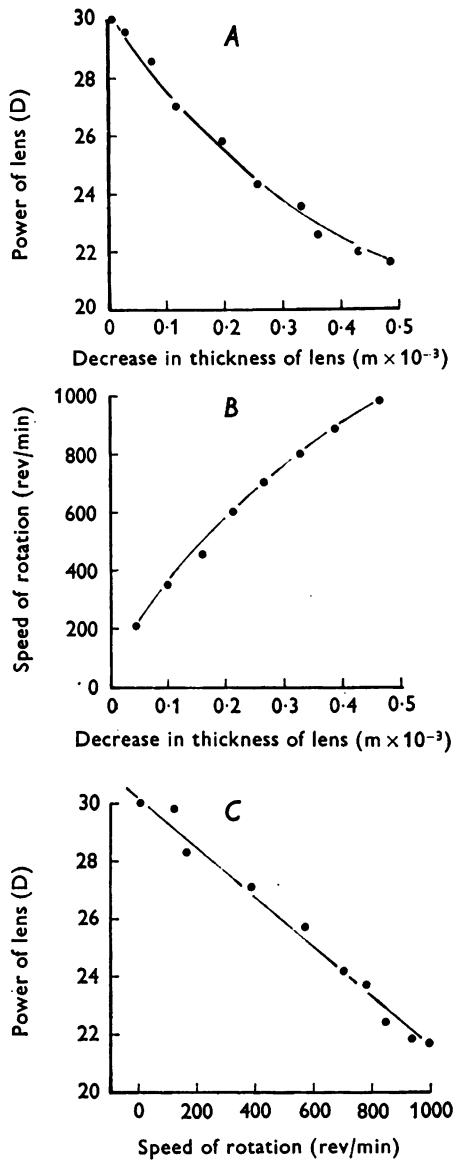

Text-fig. 6. Graphs showing the characteristics of a human lens (aged 19 yr) necessary to calculate the force of contraction of the ciliary muscle. *Note:* (i) graph *A* is prepared from measurements made in the apparatus shown in Text-fig. 3; (ii) graph *B* is prepared from measurements made in the apparatus used for measuring spinning strains (Fisher 1971, Fig. 3); (iii) graph *C* is derived from graphs *A* and *B* using the decrease in thickness of the lens as the transfer variable.

against the decrease in polar thickness of the lens when flattened by zonular tension produced by the apparatus shown in Text-fig. 3.

(ii) After the lens had been isolated it was spun around its antero-posterior polar axis, its change in thickness measured by a microscope and its dimensions recorded by flash photography. A second graph (Text-fig. 6*B*) was then prepared showing speed of rotation plotted against the decrease in polar thickness of the lens.

(iii) A speed of rotation was read off from graph *B* which corresponded to a change of thickness of graph *A*. A third graph (Text-fig. 6*C*) was then constructed showing the dioptric power of the lens against its speed of rotation.

In addition to the above experiments by simultaneous measurement the change in dioptric power of the lens while in the cell was also related to a change in radius of the ciliary ring (see Text-fig. 5).

Calculation of the force of contraction exerted by the entire ciliary body

As it has been shown previously that a change in the thickness of the lens due to spinning forces is similar to that occurring during accommodation *in vivo* (Fisher, 1971, p. 158), this variable was used to relate changes in dioptric power with spinning forces. It has also been shown that by cutting the lens capsule of the excised lens it becomes flatter, and the pressure at the equator of the intact juvenile lens is about 45 Nm⁻² greater than at its poles (Fisher, 1973, Fig. 1). The pressure at the poles of the excised lens has recently been found to be about 20–25 Nm⁻² (unpublished) so that the pressure within the capsule at the equator of the unaccommodated lens is of the order of 65–70 Nm⁻². There is evidence that this is reduced to a low value when the zonule is tense and the lens unaccommodated, because *in vivo*, tent-like elevations of the capsule are produced at the insertion of the zonule. These data suggest therefore that the change in equatorial pressure of the lens during maximal accommodation is some 65–70 Nm⁻² (Δf_{ca}).

From Text-fig. 6*C* a spinning speed of about 975 rev/min. is required to reduce the thickness of the lens to the unaccommodated state. This means that the pressure produced by spinning forces on the equatorial capsule (Appendix eqn. (1.2) $\rho = 1.03 \times 10^3$ kg m⁻³, $a_a = 4.3 \times 10^{-3}$ m) amounts to 66 Nm⁻² (Δf_{csm}).

Thus a relaxation of the zonule increases the equatorial pressure on the capsule of the lens by an amount similar to the increase of pressure produced by radial stresses induced by centrifugal forces. Therefore, when either pressure change produces a similar change in the thickness of the lens they are considered to be equal. Accordingly, total ciliary force is calculated from Appendix eqns. (2)–(5)

$$F_{CB} = \frac{2}{3}\pi a_a^2(a_u t_u \Omega_u^2 - a_a t_a \Omega_a^2)\rho,$$

where $\Omega_a \rightarrow \Omega_u$ is such $st_a = st_u$.

F_{CB} = radial force exerted by the entire ciliary body (N).

a_a = equatorial radius of accommodated lens (m)

a_u = equatorial radius of unaccommodated lens (m)

a_s = equatorial radius of spinning lens (m)

t_u = polar thickness of unaccommodated lens (m)

t_a = polar thickness of accommodated lens (m)

st_a = change in thickness of lens under zonular tension (m)

st_s = change in thickness of lens when spinning (m)

ρ = density of lens substance (kg m⁻³)

Ω_a = equivalent speed of rotation of lens when eye is accommodated (rad sec

Ω_u = equivalent speeds of rotation of lens when eye is unaccommodated (rad sec⁻¹).

RESULTS

Dioptric power/strain curve

A typical curve relating increase in radius of the ciliary ring and the decrease in the dioptric power of the lens is shown in Text-fig. 5. The lower portion of the curve shows the point at which the lens is in the unaccommodated state with maximum zonular tension and when any further increase in ciliary radius has little effect on the dioptric power (last open circle to last star point). Before this, however, each small change in the ciliary ring radius (0.1 mm) changed the power of the lens by about 1.5 D (19 yr old lens). At the upper portion of the curve when zonular tension is low a change of 0.1 mm in the radius of the ciliary ring corresponds to only 0.2 D change in power of this lens.

Since the force of contraction of the ciliary muscle counters radial zonular tension the opposite relationship holds for this contractile force which is highest at the upper part of the curve when the lens is in the accommodated state. Thus a low force of contraction corresponds to the unaccommodated part of the curve where changes in dioptric power of the lens for a given reduction in the radius of the ciliary ring are greatest. It will be seen that the decrease in radius of the ciliary ring allows the lens, as evidenced by its dioptric power, to return completely to its original state (open circles). Furthermore, there is no evidence of hysteresis in the preparation when it has completed a cycle of stress and strain. This gives one confidence that damage to the ciliary body, zonule and lenticular complex has not occurred, and the preparation accurately represents stress/strain occurring *in vivo*.

Accommodation/age curve

In Text-fig. 7 the maximum change in power of the lens is plotted against age. As shown from Text-fig. 5 the maximum amplitude of accommodation is obtained by stressing the lens to the point where little change in accommodation occurs with further increases in stress. These data indicate that the maximum amplitude of accommodation is reduced on average to zero by the age of 57 yr.

Accommodation/force curve

From Text-fig. 6C it will be seen that the dioptric power of the lens is linearly related to the speed of rotation. However, as the speed of rotation is proportional to the square root of the centrifugal force (Appendix eqns. (2)–(3)) this means that for this lens a change in lens power is proportional to the square root of the force.

To investigate this relationship further the combined plots of dioptric

power against force of several lenses were taken together. Text-fig. 8 shows these plots both on linear (Text-fig. 8A) and logarithmic scales (Text-fig. 8B). For five lenses aged between 16 and 24 yr, ciliary force

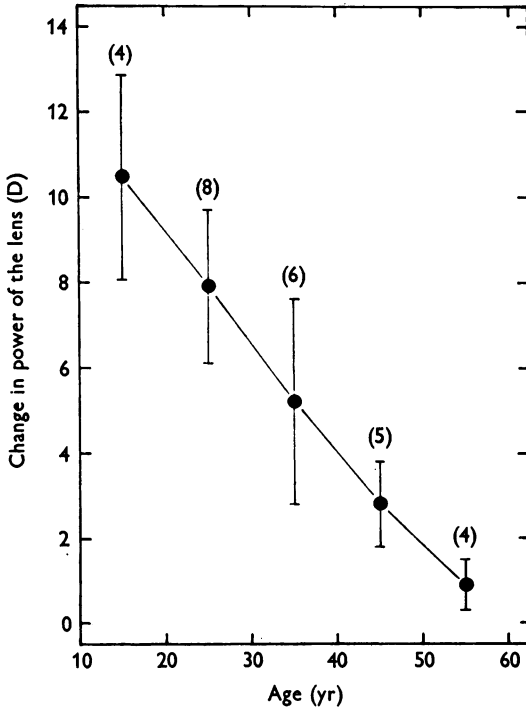

Text-fig. 7. Changes in the maximum power of the lens with age obtained by the apparatus shown in Text-fig 3 ($n = 27$). (), number of values; \bar{D} , mean value and standard deviation per decade; Maximum power of the lens may be calculated from $D = a + bA$ where $D =$ change in amplitude of accommodation in dioptries (m^{-1}), A , age (yr). Constants. $a = 14.3$, (D), $b = -0.25$ (D/yr). Significance of changes with age in maximum amplitude of accommodation, $r = -0.874$, $P < 0.001$. Variance ratio 80.9 in excess of 0.1% critical point. The polynomial values are only appropriate between the ages of 15 and 60 yr.

(F_{CB}) and amplitude of accommodation (D) are related by the equation

$$D = a(F_{CB})^b$$

where $a = 0.158$, and $b = 0.570$. Similar results were obtained from the pooled values of three lenses aged between 40 and 45 yr where $a = 0.133$ and $b = 0.422$. Thus for the younger group of lenses the power coefficient is slightly greater than the square root function whereas in the older group

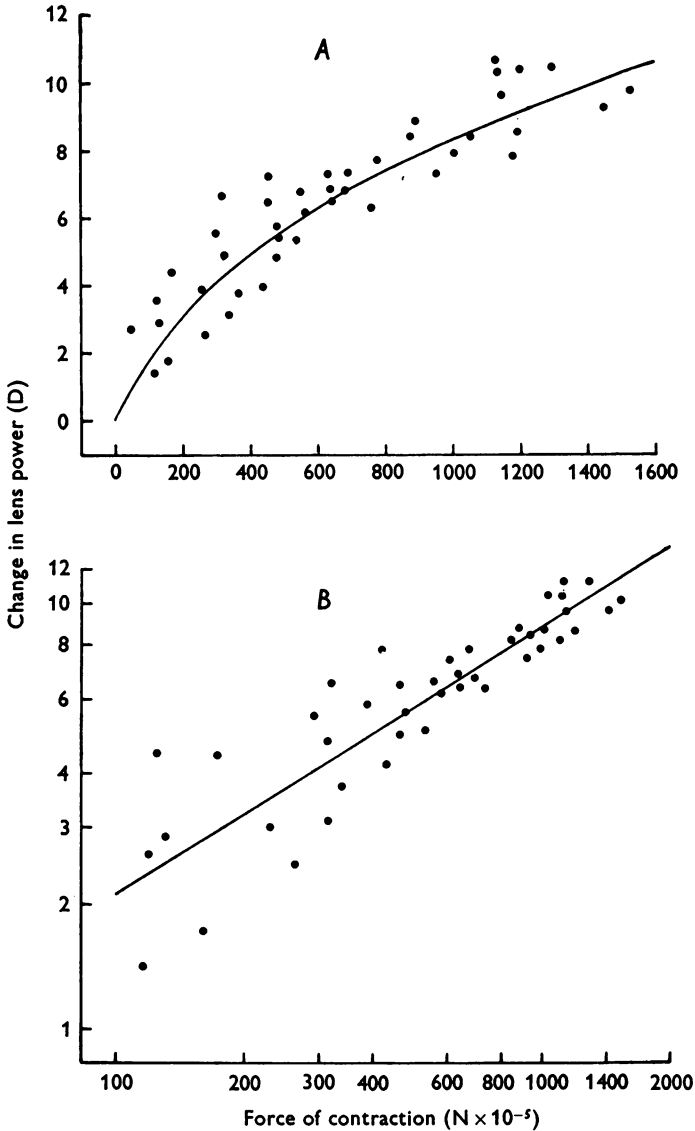

Text-fig. 8. Graph showing changes in dioptric power of the lens plotted against force of contraction of the ciliary muscle. *Note:* (i) graph *A* shows linear plots of the pooled results ($n = 43$) from five lenses (mean aged 22 yr) with a fitted curve derived from the equation $D = 0.158F_{CB}^{0.57}$. Where D = change in power of lenses (D) (m^{-1}), and F_{CB} = force of contraction of the ciliary muscle ($N \times 10^{-5}$). (ii) graph *B* shows logarithmic plots of the same data fitted to the equation $D = a + bF_{CB}$. Constants: $a = -0.80$, $b = 0.57$. Significance of change in dioptric power with force $r = 0.775$, $P < 0.001$. Variance ratio 63.1 in excess of 0.1% critical point.

it is slightly less. The effect of these variations in coefficient is shown in Text-fig. 9. It will be seen that the use of a 'square root law' relating force to change in lens power produces a small overestimate of about one dioptre in the ability of the ciliary muscle to change the power of the lens during maximal accommodation. It would seem therefore that a simple square root function when combined with an appropriate coefficient (Text-fig. 11) can adequately describe the relationship between changes in ciliary muscle force and the consequent change in dioptric power of the lens.

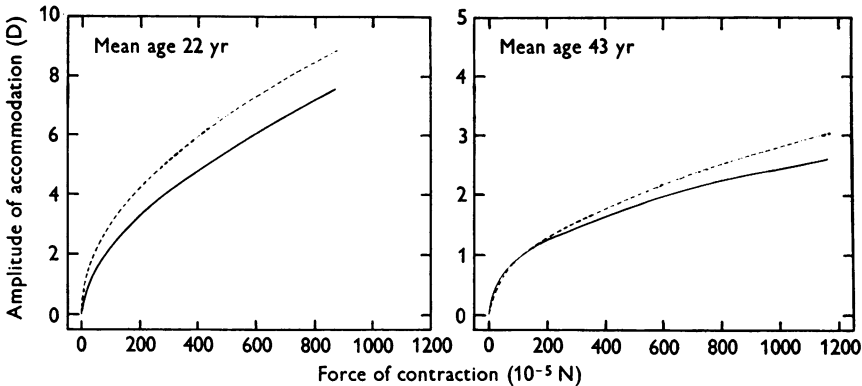

Text-fig. 9. Change in lens power plotted against force of contraction of the ciliary muscle. — results calculated from pooled values. Mean age 22 yr (five lenses), $D = 0.158 (F_{CB})^{0.570}$; mean age 43 yr (three lenses), $D = 0.133 (F_{CB})^{0.422}$. ---- results calculated from $D = K_{df}\sqrt{F_{CB}}$, where $K_{df} = 0.299$ and 0.089 at 22 and 43 yr respectively, Text-fig 1. $F_{CB} = 876$ and 1174×10^{-5} N at 22 and 43 yr respectively, Text-fig 10.

Maximum force of accommodation/age

In Text-fig. 10 the force of accommodation corresponding to the maximum dioptric change in the lens, in the range for complete reversibility of change in lens shape, is plotted against age. It is seen that after 30 yr of age the force of accommodation steadily rises to a maximum and then may decrease to its juvenile value by 60 yr of age. This would agree with the findings of Swegmark (1969). He recorded changes in the electrical resistance of the ciliary muscle during accommodation and showed that the activity of the muscle as revealed by changes in impedance remained unimpaired at least until the age of 60 yr.

Dioptric force coefficient/age curve.

The dioptric force coefficient is determined by the amplitude of accommodation which is obtained at a given age for a given force of contraction

of the ciliary muscle, and is shown plotted against age in Text-fig. 11. When the square root of the force is multiplied by the dioptric force coefficient the amplitude of accommodation at a given age is obtained. The coefficient declines rapidly with age, and it indicates that despite constant or even increasing force of contraction of the ciliary muscle, the lens becomes increasingly more difficult to deform as age advances.

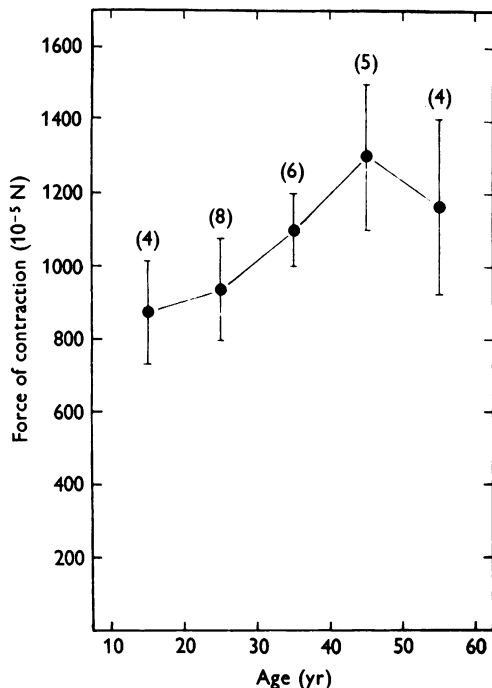

Text-fig. 10. Maximum force of contraction of the entire ciliary muscle plotted against age ($n = 27$). (), number of values. \bar{F} , mean value and standard deviation per decade. Maximum force of contraction may be calculated from $F_{CB} = a + bA + cA^2 + dA^3$, where F_{CB} = force of contraction of the ciliary muscle ($N \times 10^{-5}$) A = age (yr). Constants: $a = 1,690$, $b = -96.5$, $c = 3.50$, $d = -0.0346$. Significance of changes in force of contraction with age, $r = 0.527$, $P < 0.01$. Variance ratio 7.44 just at the 0.1% critical point. The polynomial values are only appropriate between the ages of 15 and 60 yr.

This force coefficient gives a good prediction of the amplitude of accommodation when compared with values from pooled results (Text-fig. 9). An appropriate dioptric force coefficient (K_{dr}) for the average age of the two groups of pooled results (22 and 43 yr) when used to calculate the amplitude of accommodation on the basis that

$$D = K_{dr}\sqrt{F_{CB}}$$

(where D = amplitude of accommodation (m^{-1}), F_{CB} = force of contraction of the ciliary muscle ($N \times 10^{-5}$)) is only at the most some 10 % greater than any of the values obtained from the pooled results. Of course the reason for the difficulty in deforming the lens as age advances is unexplained. However, it may be due to weakening of the lens capsule (Fisher, 1969) and an increase in the Young's Modulus of elasticity of the lens substance (Fisher, 1973).

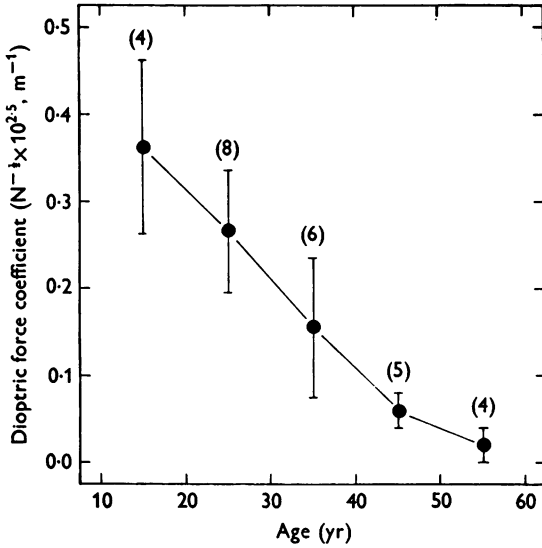

Text-fig. 11. Dioptric force coefficient plotted against age ($n = 27$). (), number of values. $\bar{\Phi}$, mean value and standard deviation per decade. Dioptric force coefficient (K_{df}) may be calculated from $K_{df} = D/\sqrt{F_{CB}}$, where, D = amplitudes of accommodation in dioptries (m^{-1}), F_{CB} = force of contraction of ciliary muscle ($N \times 10^{-5}$), A = age (yr). $K_{df} = a_k + b_k A + c_k A^2$. Constants: $a_k = 0.675$, $b_k = 0.020$, $c_k = 0.000147$. Significance of changes in dioptric coefficient with age, $r = -0.878$, $P < 0.001$. Variance ratio 47.8 in excess of the 0.1 % critical point. The polynomial values are only appropriate between the ages of 15 and 60 yr.

DISCUSSION

When the crystalline lens is stressed through its zonule by an increase in the radius of the ciliary ring (Text-fig. 3) it flattens and its dioptric power decreases (Pl. 1). When associated with maximal tension in the zonule and consistent with a completely reversible deformation of the lens (Text-fig. 5), this change in power follows closely the change in the maximal amplitude of accommodation which is observed in the living eye (Text-fig. 12). However, the changes observed are some 1.25 D less at every age than the average of values obtained *in vivo* by many observers.

It must be remembered that the *in vivo* values were obtained by measuring the point at which blurring of an object is first noticed by the observer. From the experiments of Hamasaki, Org & Marg (1956) and Miles (1953) it would appear that this method of measurement gives a higher value than the true amplitude of accommodation.

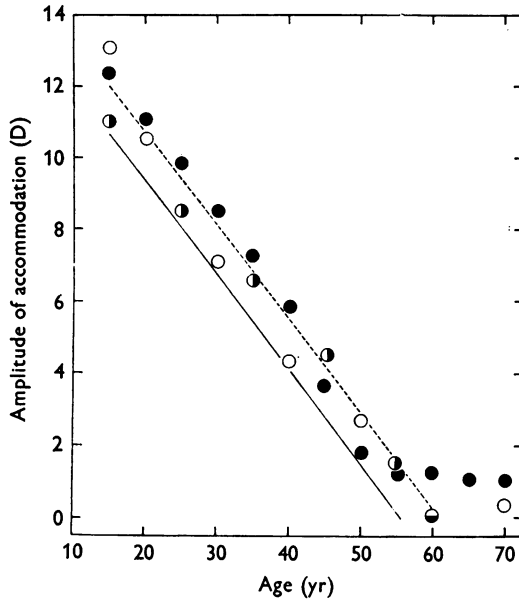

Text-fig. 12. Presbyopic changes in maximum amplitude of accommodation (a comparison of *in vivo* and *in vitro* data). ●, Duane (1922); ●, Brückner (1959) (mean per decade); ●, Hamasaki *et al.* (1956); ○, Donders (1864). The average linear regression of *in vivo* results is shown by the dashed line; mean linear regression of *in vitro* results (redrawn from Text-fig. 6) by the continuing line.

They have measured the amplitude of accommodation both by retinoscopy and the 'blur' technique and found the former some 1.0–1.5 D less than that obtained by the 'blur' technique. It would seem therefore that as a similar difference exists between the amplitude of accommodation as measured by the 'blur' technique and by the apparatus, the latter is capable of measuring the true change in focal power of the lens.

Therefore, any calculations based on the dioptric force coefficient found by the present apparatus must take into account this discrepancy when topics such as blurring of print are being considered.

The relation between amplitude of accommodation and the force of contraction of the ciliary muscle

The maximum force exerted radially through the zonule by the entire ciliary muscle to reduce zonular tension to zero is of the order of about 1000 dyn and the force used for near vision is very small – some 50 dyn, and just about 5% of that which can be exerted (Text-fig. 13). The great

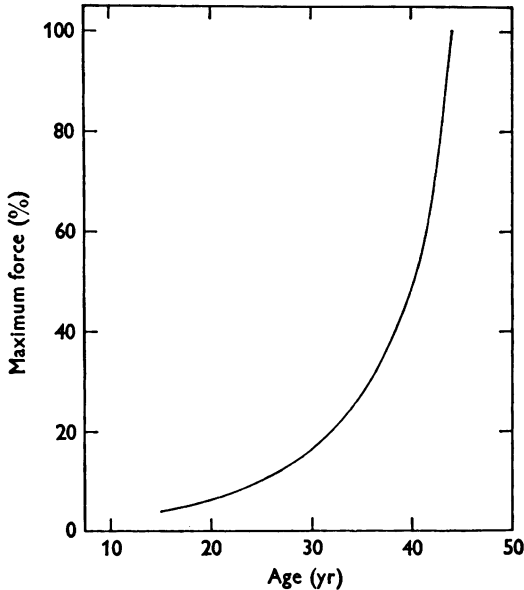

Text-fig. 13. Percentage of maximum force available in the ciliary muscle which is required for near vision. *Note:* (i) amplitude of accommodation, for near vision assumed to be 3.5 D by the 'blur' technique. (ii) % maximum force (P) calculated from $P = [2.25/K_{dr}]^2 \times 100/F_{CB}$, where K_{dr} = dioptric force coefficient from ($N^{-\frac{1}{2}} \times 10^{25} m^{-1}$) (Text-fig. 11), and F_{CB} = maximum force of contraction of the ciliary muscle ($N \times 10^{-5}$) (Text-fig. 10).

difference in youth between maximal and normal accommodative force is due to the non-linear relationship between force and the amplitude of accommodation. This is contrary to most people's assumption of a proportionate relationship and indeed if there were linearity some 250 dyn of force would be required for near vision.

Evidence for the increase of ciliary muscle power as age advances

Although it is clear that the contractile force of the ciliary muscle and the change of shape of the lens are closely inter-related the evidence for increased or decreased contraction of the ciliary muscle is difficult to obtain. Thus, presbyopia has been attributed to: (i) decreased contractile

power of the ciliary muscle in the presence of a lens the physical properties of which have changed little with age (Duane, 1931); (ii) increased ciliary muscle power because the ageing lens has become more difficult to deform (Helmholtz, 1855); and (iii) an increase in the equatorial diameter of the lens and volume of the ciliary body with a reduction in circumlental space (Weale, 1962).

Table 1. The effect of constant or increasing force of ciliary muscle contraction on the amplitude of accommodation as age advances.

Age (yr)	Amplitude of accommodation (Dioptres)		
	Constant force	Increasing force	Difference
20	9.7	9.7	0.0
30	6.0	6.5	0.5
40	3.1	3.9	0.8
50	0.6	1.2	0.6

(a) Amplitude of accommodation for constant force calculated from $D = K_{dr} \sqrt{848}$, K_{dr} = dioptric coefficient obtained from Fig. 11.

(b) Amplitude of accommodation for increased force obtained from Fig. 10.

Fisher (1973) showed that if we allow that ciliary muscle activity is always able to move the capsulo-zonular attachments relative to the lens substance by the same distance throughout life, then senile changes in the crystalline lens are sufficient to abolish accommodation by the age of 61 yr. This still leaves the possibility that compensatory and increased ciliary muscle contractions may also occur although there is little possibility of decreasing muscle power with age. The present experiments suggest that the force of contraction rises steadily to reach a maximum around age 50 yr when the force has increased by about one half compared to that of youth (Text-fig. 10).

Previous estimates of ciliary muscle power have often depended on the measurement of the amplitude of accommodation in association with convergence. Apart from the fact that changes in the amplitude of convergence do not depend necessarily entirely on an associated accommodation stimulus, it has now been found that the force of contraction is approximately related to the square of the amplitude of accommodation, so maximal changes in force may produce little change in the dioptric power of the lens as age advances. This is shown in Table 1 where despite increasing ciliary muscle power the maximum difference in accommodation when compared with the theoretical situation of constant ciliary muscle activity throughout life is only about 0.8 D.

It is now clear why it is so difficult to deduce the amount of ciliary muscle force from the amplitude of accommodation in the ageing lens, since the difference may be smaller than the depth of focus of the eye.

The force of contraction of the ciliary muscle necessary for near vision

Donders (1864) found that glasses were often required when the total accommodation became less than two thirds of that required for reading. In reading about 3.5 D of accommodation are required. This means that by the 'blur' technique the amplitude of accommodation should be 5.25 D. As our present experiments show values some 1.25 D less than the 'blur' technique, 4.0 D of accommodation must be provided by contraction of the ciliary muscle. From Fig. 7 this is just available at 40.5 yr of age. By 44 yr of age however the 2.25 D of accommodation provided by the ciliary muscle just make reading possible. Since however a maximal contraction of the ciliary muscle is necessary (Text-fig. 13) it cannot be sustained for long.

Thus, the present experiments predict that in the early forties glasses become at first necessary for comfort and finally obligatory for reading.

Just before the onset of presbyopia the force of contraction of the ciliary muscle begins to increase rapidly and this is manifested by marked hypertrophy of the muscle at this time (Stieve, 1949). However, this hypertrophy has little influence on presbyopia because the increase in force does not produce a proportionate increase in the amplitude of accommodation, and the lens is becoming ever more resistant to deformation.

I would like to thank Miss A. Miller for technical assistance, the computer programming by Mr Brian Augier, the expert manufacture of the cell and lens stressing equipment by Mr G. R. Mould, the drawing of Figs. 1, 2, 3, 4 and 14 by Mr T. R. Tarrant, and the Medical Research Council for an equipment grant.

APPENDIX

1. *The equatorial pressure of the spinning lens (Text-fig. 14A)*

a_a = equatorial radius of the accommodated lens (m),

a_u = equatorial radius of the unaccommodated lens (m),

a_s = equatorial radius of the spinning lens (m),

t_u = polar thickness of unaccommodated lens (m),

t_a = polar thickness of accommodated lens (m),

st_s = change in polar thickness of lens (t_s) when spinning (m),

st_a = change in polar thickness of lens (t_a) when subjected to zonular tension (m),

w = angular speed of rotation of the lens (rad sec⁻¹),

f_s = horizontal pressure at capsular surface at a point P (Nm⁻²),

Δf_{esm} = mean increase of horizontal equatorial pressure exerted by lens substance on lens capsule due to spinning of the lens (Nm⁻²),

Δf_{eu} = reduction of mean equatorial pressure due to lens being subjected to zonular tension and reducing in dioptric power (Nm⁻²),

ρ = density of lens substance (kg m⁻³).

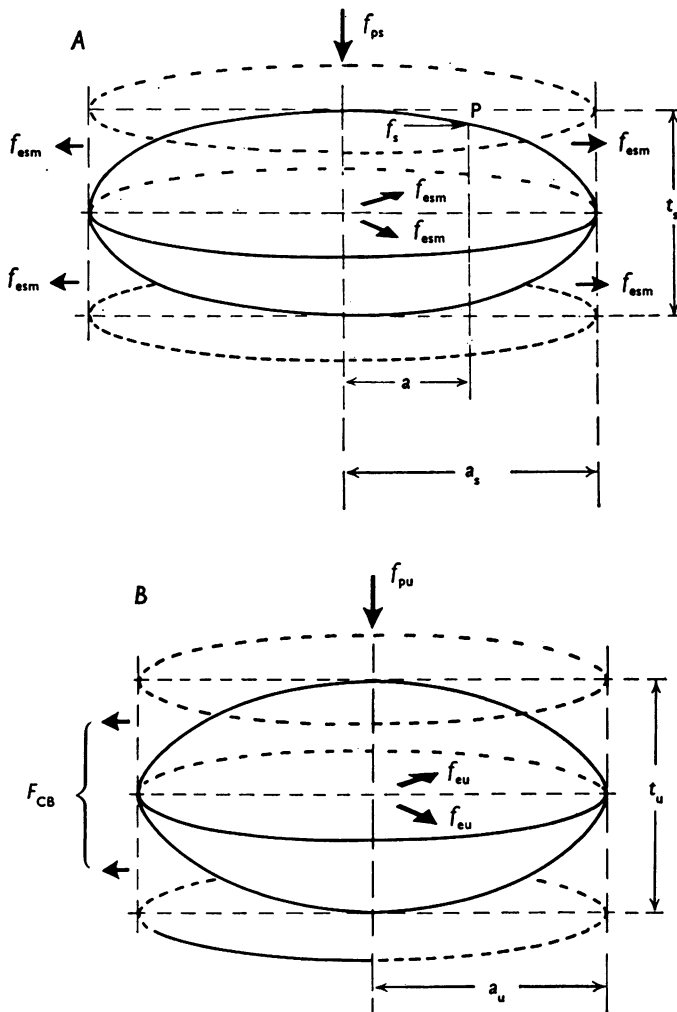

Text-fig 14. Diagrams of relationship between changes in lens profile when under zonular tension or spinning forces. *A*, lens under centrifugal forces. *B*, lens under zonular tension and unaccommodated.

Now the lens capsule has a Young's Modulus of elasticity of the order of $4 \times 10^6 \text{ Nm}^{-2}$ (Fisher, 1969), whereas the lens substance has an elasticity modulus of about $2 \times 10^3 \text{ Nm}^{-2}$ (Fisher, 1971). Because the lens substance has an elasticity modulus about 2000 times less than the lens capsule, the lens when spinning may be considered for the purpose of capsular pressure calculation as enclosed in a rigid capsule filled with a viscous fluid. Under these circumstances the horizontal pressure acting on the lens

capsule due to spinning may be considered as the same as that developed in a fluid due to a 'forced vortex'.

At any point P in a 'forced vortex' of radius a we have

$$f_s = \frac{1}{2}w^2a^2\rho. \quad (1.1)$$

Allowing that the lens is an ellipsoid of revolution the mean radius is two thirds its equatorial radius. Thus

$$\Delta f_{esm} = \frac{1}{3}w^2a_s^2\rho. \quad (1.2)$$

Let Ω be speed of rotation when $st_s = st_a$. Then if it be assumed that the changes in pressure at the poles of the spinning or accommodating lens are similar, we have $st_s = st_a$

and

$$\Delta f_{ea} = \frac{1}{3}a_s^2\rho\Omega^2. \quad (1.3)$$

Note that previously the lens was treated as a simple elastic body (Fisher, 1973, eqn. (1.3)). Under these circumstances the numerical coefficient in the eqn. (1.3) was 7/24 compared with the 1/3 at present. Thus it will be seen that the mean stress in an isometric elastic lens or the mean pressure deduced from the present approach to the problem differs only by about 4%.

2. Total radial force exerted by the ciliary muscle (Text-fig. 14B)

Z_u = radial force in zonule when eye is unaccommodated (N),

Z_a = radial force in zonule when eye is accommodated (N),

F_{CB} = equivalent radial force in ciliary muscle when eye accommodated (N),

Ω_u = equivalent speed of rotation of lens when eye is unaccommodated (rad/sec),

Ω_a = equivalent speed of rotation of lens when eye is accommodated (rad/sec).

Let us assume that the horizontal component of pressure on the capsule acts over surface of the cylinder shown dotted. Thus

$$Z_u = 2a_u t_u f_{eu}. \quad (2.1)$$

Now

$$F_{CB} = Z_u - Z_a. \quad (2.2)$$

And from Appendix eqns. (1.3) and (2.1),

$$Z_u = \frac{2}{3}na_u t_u a_s^2 \rho \Omega_u^2. \quad (2.3)$$

Also

$$Z_a = \frac{2}{3}\pi a_a t_a a_s^2 \rho \Omega_a^2. \quad (2.4)$$

Thus from Appendix eqns. (2.2), (2.3) and (2.4),

$$F_{CB} = \frac{2}{3}\pi a_s^2 (a_u t_u \Omega_u^2 - a_a t_a \Omega_a^2) \rho. \quad (2.5)$$

If zonule fully released in unaccommodated eye $Z_u = 0$ and,

$$F_{CB} = -\frac{2}{3}\pi a_s^2 a_a t_a \Omega_a^2 \rho. \quad (2.6)$$

REFERENCES

- BRÜCKNER, R. (1959). Über Methodon longitudinaler Alternforschung am Auge. *Ophthalmologica, Basel* **138**, 59-75.
- DONDERS, F. C. (1864). *On the Anomalies of Accommodation and Refraction of the Eye*. London: New Sydenham Soc.
- DUANE, A. (1922). Studies in monocular and binocular; accommodation with their clinical applications. *Am. J. Ophthal.* **5**, 865-877.
- DUANE, A. (1931). Accommodation. *Archs Ophthal., N.Y.* **5**, 1-14.
- FISHER, R. F. (1969). Elastic constants of lens capsule *J. Physiol.* **201**, 1-19.
- FISHER, R. F. (1971). The elastic contents of the human lens. *J. Physiol.* **212**, 147-180.
- FISHER, R. F. (1973). Presbyopia and the changes with age in the human crystalline lens. *J. Physiol.* **228**, 765-779.
- FISHER, R. F. & PETTET, B. E. (1973). Presbyopia and the water content of the Human Crystalline lens. *J. Physiol.* **234**, 443-447.
- HAMASAKI, D. & ORG, J. & MARG, E. (1956). The amplitude of accommodation in presbyopia. *Am. J. Optom.* **33**, 3-14.
- HELMHOLTZ, H. (1855). Über die Akkommodation des Auges *Albrecht v Graefes Arch. Ophthal.* **1**, 1-74.
- HESS, C. (1904). Beobachtungen über den Akkommodationsuorgang *Klin. Mbl. Augenheilk.* **42**, 309-315.
- MILES, P. W. (1953). Depths of focus and amplitude of accommodation through trifocal glasses. *Archs. Ophthal. N.Y.*, **49**, 271-279.
- STIEVE, R. (1949). Über den Bau des Menschlichen Ciliarmuskels, sein Veraonderungen Während des lebens und seine Bedeutung für die Akkommodation. *Anat. Anz.* **97**, 69-79.
- SWEGMARK, G. (1969). Studies with impedance cyclography on human ocular accommodation at different ages. *Acta ophthal.* **47**, 1-21.
- WEALE, R. A. (1962). Presbyopia. *Br. J. Ophthal.* **46**, 660-668.

EXPLANATION OF PLATE 1

Photographs of the profiles of a human lens (aged 19) with anterior pole uppermost. (a) Lens in stressing apparatus (Text-fig. 2 and 4) under very low zonular tension (accommodated). (b) Excised stationary lens. (c) Lens in stressing apparatus (Text-figs. 2 and 4) under maximum zonular tension (unaccommodated). (d) Excised lens spinning at speed (975 rev/min) to produce an amount of flattening similar to (c). Note: equator shown in every case by a thick white line while a thin white line passes through anterior pole of lenses a and b. Note: decrease in anterior polar thickness of spinning unaccommodated lens.

