

**EFFECTS OF INTRAVENTRICULAR AND INTRA-  
HYPOTHALAMIC INJECTION OF NORADRENALINE  
AND 5-HT ON BODY TEMPERATURE IN  
CONSCIOUS RABBITS**

BY K. E. COOPER, W. I. CRANSTON AND A. J. HONOUR

*From the M.R.C. Body Temperature Research Unit, Department of  
the Regius Professor of Medicine, Radcliffe Infirmary, Oxford*

*(Received 24 May 1965)*

There is ample evidence that a most important part of the regulation of body temperature depends on temperature receptors situated within the brain. These receptors and their associated regulating mechanism are usually presumed to lie within the hypothalamus, and there is much evidence to support this view (Hardy, 1961). Their histological structure and the means whereby they respond to temperature fluctuations are not known. During fever, endogenous pyrogen (Atkins, 1960), acting at the site of the central regulating mechanism, causes the body temperature to rise, and the mechanism of this action also remains obscure.

It has long been known (Amin, Crawford & Gaddum, 1954; Vogt, 1954; Carlsson, Falck, Hillarp & Torp, 1962; Bertler, 1961) that the hypothalamus contains high concentrations of 5-hydroxytryptamine (5-HT) and noradrenaline. It has been suggested (Brodie & Shore, 1957; von Euler, 1961) that these amines might be concerned with temperature regulation. Feldberg & Myers (1963, 1964, 1965) found that 5-HT injected into the anterior hypothalamus or the lateral ventricle of the cat caused the animal's temperature to rise, and noradrenaline injected into these sites caused it to fall. On the basis of these observations they have proposed that body temperature regulation might depend on the relative amounts of these two substances liberated in the hypothalamus; and thus fever might result if there was an excess of 5-HT in this region. This paper reports the effects of intracranial 5-HT, noradrenaline and pyrogens on body temperature in the rabbit.

**METHODS**

*Materials.* 1-noradrenaline 1:1000 (Laevophed, Bayer), and solid 5-HT were dissolved in sterile saline at the desired concentration. The solid 5-HT was not known to be pyrogen-free. Since bacterial pyrogens do not diffuse through cellophane dialysis membranes, a stock solution of 5-HT was put into a sterile cellophane dialysis sac and dialysed against an equal

volume of pyrogen-free 0.9% sodium chloride solution. The dialysate was a pyrogen-free solution of 5-HT containing 2000  $\mu\text{g}/\text{ml}$ ., and this concentration was checked by bio-assay. Histamine acid phosphate (British Drug Houses) supplied in ampoules 1  $\mu\text{g}/\text{ml}$ ., eserine and solid acetylcholine, dissolved in sterile, pyrogen-free saline, were also used. Two types of pyrogen were used. Bacterial pyrogen—a purified lipopolysaccharide obtained from *S. abortus equi* (Pyrexal, Wander)—and leucocyte pyrogen. The leucocyte pyrogen was made by incubating peritoneal exudate white cells (Fessler, Cooper, Cranston & Vollum, 1961) in pyrogen-free normal saline for 3 hr. White cells ( $4.49 \times 10^9$ ) were incubated in 46 ml. saline after which the cells were spun off, and the supernatant fluid containing the leucocyte pyrogen was stored in sealed ampoules. All glass-ware and equipment used in preparing materials to be injected into the brain was heated to 170° C for 4 hr before use.

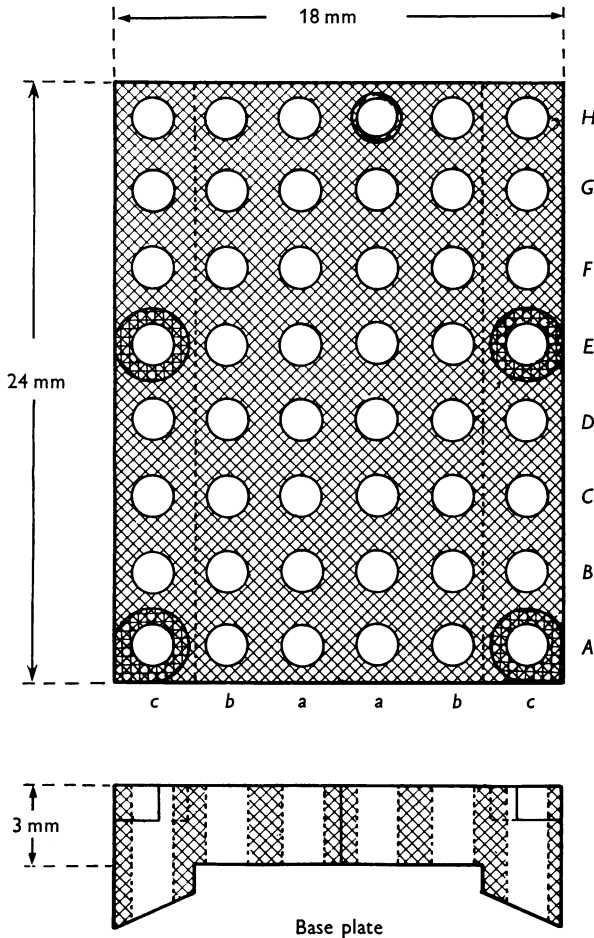

Fig. 1. Plan (upper) and sectional (lower) views of the base plate attached to the rabbit's skull. Holes on co-ordinates *Ac* and *Ec* on both sides used for skull fixation. Tapped hole *Ha* used for attachment of cannula carrier. Bregma midway between *a-a* and *A-B*.

*Insertion of cannulae into the brain*

*The attachment to the skull.* The technique was derived from the Monnier & Gangloff (1961) modification of Hess's (1932) technique. Under pentobarbitone (Nembutal, Abbott Ltd) and local cinchocaine (Xylocaine 2%, Astra-Hewlett Ltd) anaesthesia, a rectangular stainless-steel plate (the base plate) (Fig. 1) was screwed on to the skull. The base plate was drilled with holes on a rectangular lattice, each hole being at the corner of a 3 mm square (Fig. 1). The base plate was placed in a fixed relation to the intersection of the coronal and sagittal sutures and fixed to the skull using short stainless-steel self-tapping screws. Holes were

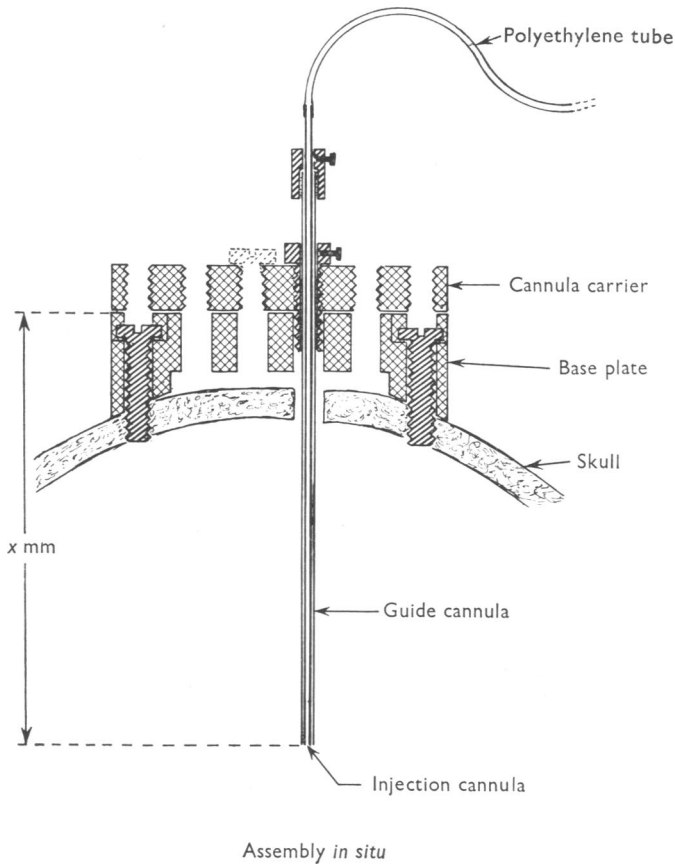

Fig. 2. Whole injection assembly attached to skull, in section.

bored through the skull beneath such holes in the base plate as were likely to be used. The whole operated area was sprayed with a mixture of antibiotics (Polybactrin, Calmic Ltd.) and the skin closed round the edges of the base plate. An Araldite (Ciba, A.R.L.) plate lubricated with sterile liquid paraffin was screwed to the top of the base plate to prevent upward growth of skin over the latter. At least one week elapsed before the animal was used for an experiment.

*Cannulae and their insertion.* A second rectangular steel plate, 2.4 cm  $\times$  1.8 cm, was drilled with a lattice of holes identical with those in the base plate. A 22 s.w.g. length of stainless-steel tubing (Accles & Pollock Standard Hypodermic Tubing) was mounted in a threaded

collet in this plate, in the appropriate hole. This guide cannula protruded below the plate by a distance  $x$  cm depending on the desired injection site. The 'guide' cannula containing a stylette of exactly the same length was thus inserted through the appropriate hole previously drilled in the skull, and the rectangular plate carrying it was screwed to the base plate (Fig. 2).

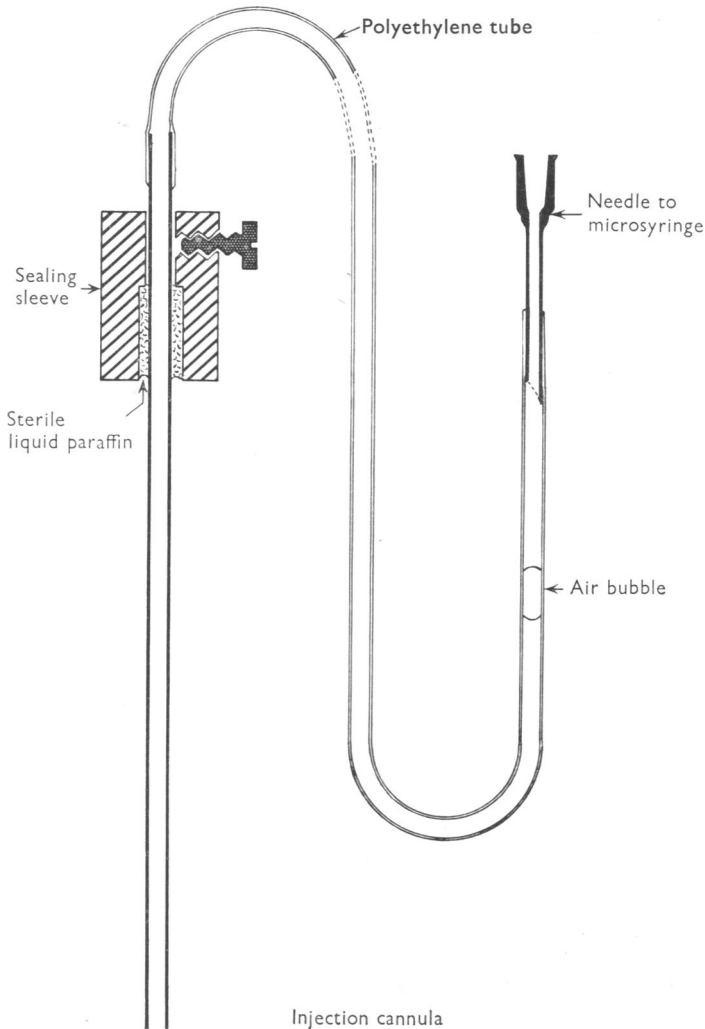

Fig. 3. Injection cannula showing oil seal.

A second cannula (26 s.w.g.) made as shown in Fig. 3, mounted in the end of a length of 1.45 mm *o.d.*, 0.75 mm *i.d.* polyethylene tubing, was inserted in place of the stylette just before an injection was given. A seal of sterile oil prevented leak-back. The guide cannula and its carrying plate were sterilized by dry heat (170° C for 3 hr). The injection cannula and its tubing were sterilized by boiling for ½ hr in a 1% solution of sodium carbonate. After boiling, they were flushed with pyrogen-free saline and then with the fluid to be injected. A small

air bubble in the polyethylene tube enabled the passage of fluid down the cannula to be confirmed (Harris, personal communication). Injections were made either with a micrometer syringe (Aglá, Burroughs Wellcome Ltd), or a Hamilton microsyringe graduated in microlitres, into the polyethylene tube. The syringes were sterilized by dry heat (170° C for at least 3 hr). The cannulae were inserted and the injections were made in conscious rabbits without any sign of distress to the animals.

*Confirmation of sites of injection*

*Lateral ventricle.* When a guide cannula had been inserted into the brain so as to enter the lateral ventricle, a snugly fitting needle attached to a 1 ml. tuberculin syringe containing saline was inserted into it. A small lump of Plasticine was attached to the syringe plunger, and the animal held so that the syringe was vertical. If the plunger ran steadily into the barrel and no leak occurred from the cannula, the correct positioning of the latter was assumed (Feldberg, personal communication), and the experiment proceeded. At the end of the experiment the animal was anaesthetized with pentobarbitone and 0.1 ml. ethyl iodophenylundecylate (Myodil, Glaxo) was injected down the guide cannula. An X-ray photograph of the skull was taken which showed the ventricles and the location of the cannula.

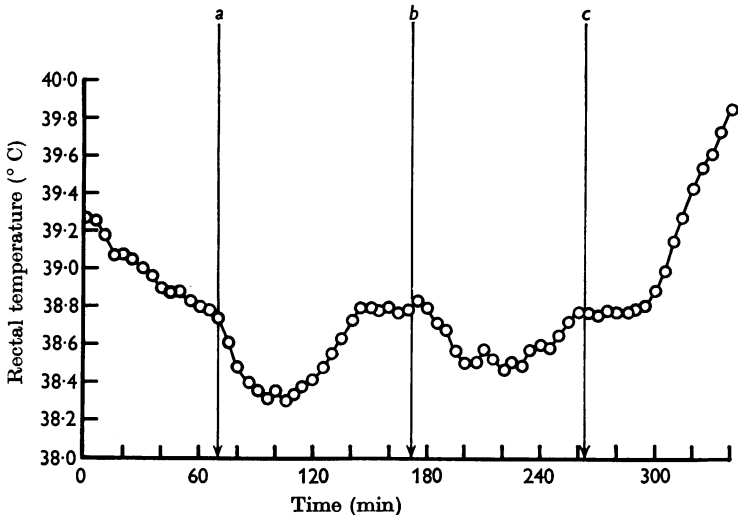

Fig. 4. Effect of intraventricular 5-HT 200  $\mu$ g in 0.10 ml. at arrows *a* and *b* and pyrexal 0.05  $\mu$ g in 0.10 ml. at arrow *c* on rectal temperature.

*Hypothalamus.* At the end of each experiment the animal was killed with pentobarbitone and the site of the injection was determined by cutting serial sections of the brain. In some experiments a small quantity of sterile, pyrogen-free, fine particulate carbon was mixed with the substance to be injected, enabling clearer identification of the site of injection to be made. The volume of brain through which the substances had diffused could not be determined with any accuracy.

*Temperature measurement.* Rectal and ear temperatures were measured with copper-constantan thermojunctions with an accuracy of at least  $\pm 0.05^\circ$  C. The ear thermocouple was attached with adhesive plaster to a shaved area of the ear mid-way between the central ear artery and the marginal vein. In some rabbits the sympathetic nerve supply to one ear was cut by the method of Feldberg (1926), in which the stellate and superior cervical ganglia are removed. Subsequently intravenous bacterial pyrogen caused vasoconstriction in the normally innervated ear but not in the sympathectomized ear.

## RESULTS

*5-HT into the lateral cerebral ventricle.* Pyrogen-free 5-HT was injected into the lateral cerebral ventricle on six occasions in three experiments on three rabbits. Doses of 200  $\mu\text{g}$  dissolved in 0.10 ml. 0.9% sodium chloride solution were used. The rectal temperature fell by between 0.3°C and 0.7°C on four occasions and did not alter following two such injections. At the end of each experiment, pyrexal 0.05  $\mu\text{g}$  in 0.1 ml. normal saline was injected into the ventricle down the same cannula. In every experiment it caused fever. An example of an experiment in which 5-HT caused the body temperature to drop is shown in Fig. 4.

*Noradrenaline into the lateral cerebral ventricle.* Two injections of 10  $\mu\text{g}$  noradrenaline (in 0.1 ml. normal saline) into the lateral ventricle caused fever, and two were without effect on the body temperature. In one experiment in which the noradrenaline injection did not cause the body temperature to change a further dose of 20  $\mu\text{g}$  was also without effect. On the two occasions when noradrenaline injections produced no rise in temperature, pyrexal 0.025–0.050  $\mu\text{g}$  injected into the same site caused fever. In one experiment noradrenaline caused a transient rise in rectal

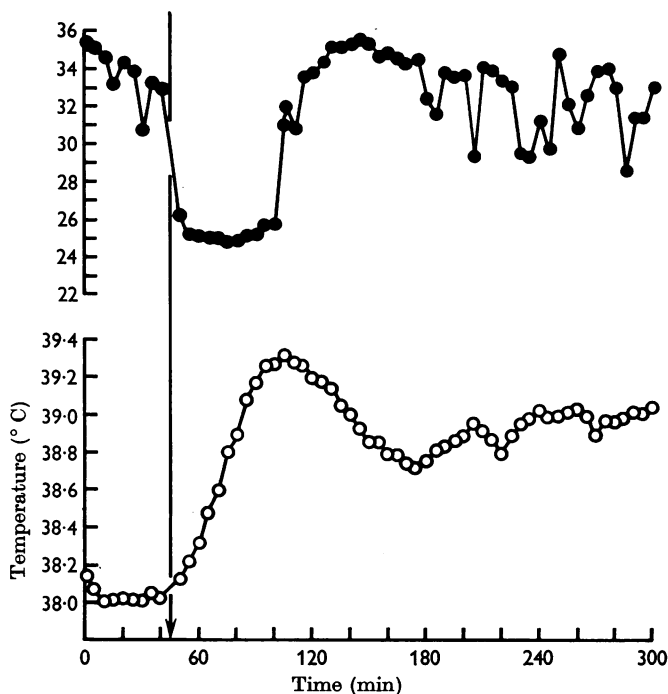

Fig. 5. Effect of intraventricular noradrenaline (10  $\mu\text{g}$ , at arrow) on rectal (open circles) and ear (filled circle) temperatures.

temperature. A subsequent injection of pyrexal caused a sustained rise in the rabbit's rectal temperature. While the temperature was thus elevated a further dose of  $10\ \mu\text{g}$  noradrenaline into the lateral ventricle again caused a further rise in temperature. When noradrenaline caused fever, the temperature rise varied from  $0.7\text{--}1.3^\circ\text{C}$ . An example of a noradrenaline-induced fever is shown in Fig. 5 in which the fall in ear temperature during the rise in body temperature can also be seen.

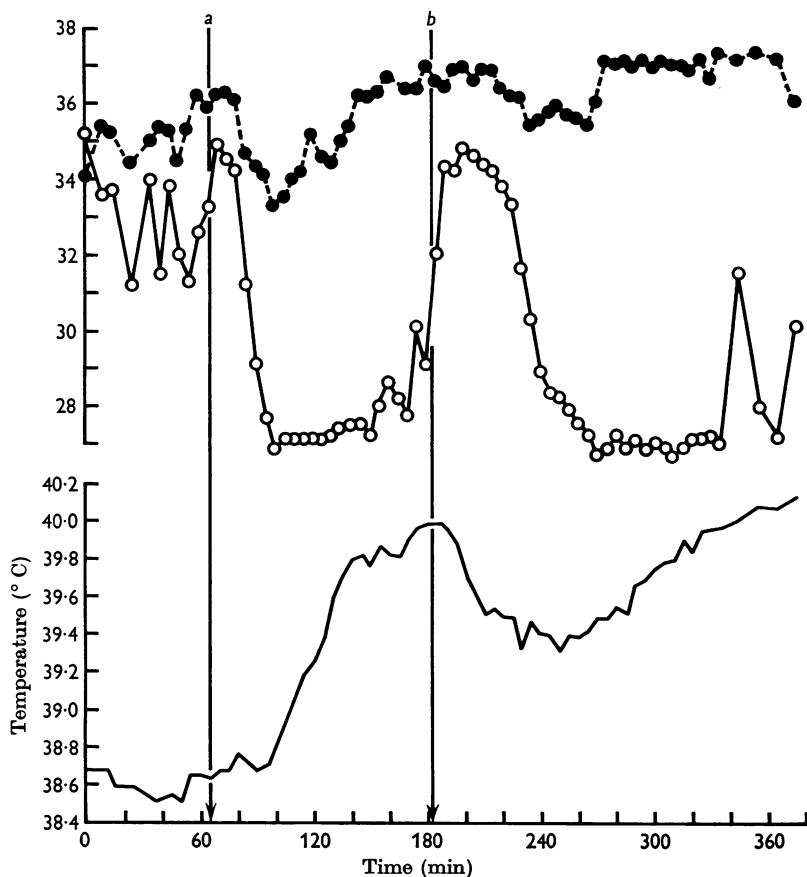

Fig. 6. Effect of 5-HT ( $45\ \mu\text{g}$  at *b*) into the anterior hypothalamus on rectal and ear temperatures during a noradrenaline induced fever. Noradrenaline,  $10\ \mu\text{g}$  given at *a*. Rectal temperature, continuous line; normal ear, open circles; sympathectomized ear, filled circles on interrupted line.

*5-HT into the anterior hypothalamus.* Two injections of  $20\ \mu\text{g}$  5-HT and one of  $2\ \mu\text{g}$  5-HT were given in  $10\ \mu\text{l}$ . saline into the anterior hypothalamus in different rabbits. They were all without effect on the rectal temperatures; subsequent injections of  $20\ \mu\text{l}$ . of endogenous pyrogen

down the same cannula into the same site caused fever on each occasion. On one occasion, 40  $\mu\text{g}$  5-HT was given into the hypothalamus during a fever caused by endogenous pyrogen previously given into that same site. There followed a rapid rise in temperature of the normally innervated ear and fall in rectal temperature. A similar result followed when 5-HT was given during a noradrenaline-induced fever (Fig. 6).

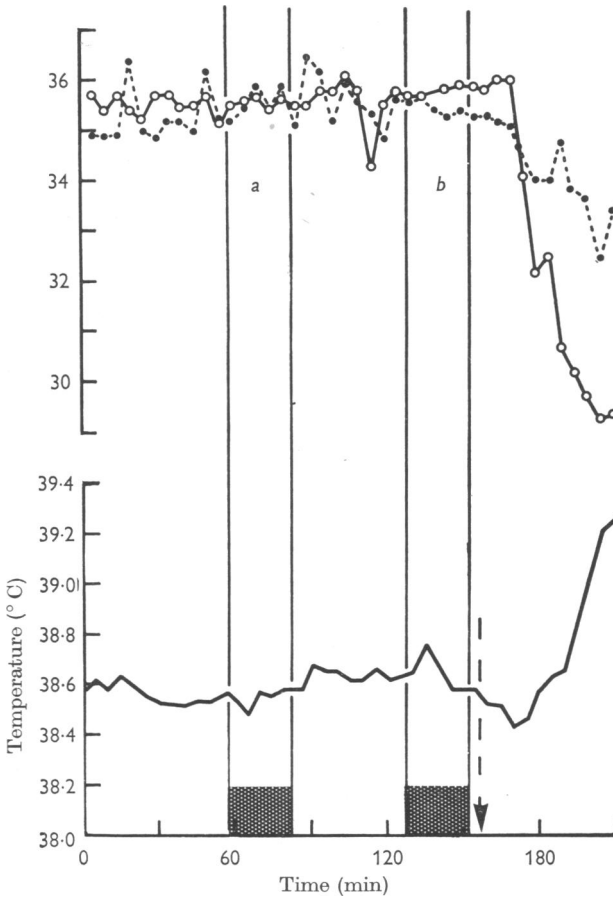

Fig. 7. Rectal ear and temperatures during hypothalamic infusion of acetylcholine (total 0.88  $\mu\text{g}$ , a) and histamine (total 12  $\mu\text{g}$ , b) and an injection of endogenous pyrogen, 20  $\mu\text{l}$ . at arrow. Rectal temperature, continuous line, normal ear, open circles; sympathectomized ear, filled circles on interrupted line.

*Noradrenaline into the anterior hypothalamus.* 10  $\mu\text{g}$  of L-noradrenaline in 10  $\mu\text{l}$ . were injected into the anterior hypothalamus on eight occasions in six rabbits. Four of these injections were followed by marked febrile responses, in one there was a doubtful fever with a rise of temperature of



just less than  $0.4^{\circ}\text{C}$  and on three occasions the animals' temperature did not alter. Two infections were given into one rabbit, one of  $2\ \mu\text{g}$  and the other of  $5\ \mu\text{g}$  of noradrenaline. Neither caused fever.

*Histamine, acetylcholine, eserine, potassium chloride, c.s.f. and plasma into the anterior hypothalamus.* Acetylcholine  $0.88\ \mu\text{g}$  infused into the hypothalamus in  $8\ \mu\text{l}$ . saline over 24 min and  $12\ \mu\text{g}$  histamine in  $12\ \mu\text{l}$ . over 24 min were without significant effect on a rabbit's rectal temperature, whereas a subsequent injection of endogenous pyrogen into the same site caused fever (Fig. 7). In another experiment,  $5.2\ \mu\text{g}$  eserine was infused into the hypothalamus in  $8\ \mu\text{l}$ . saline over 31 min and subsequently

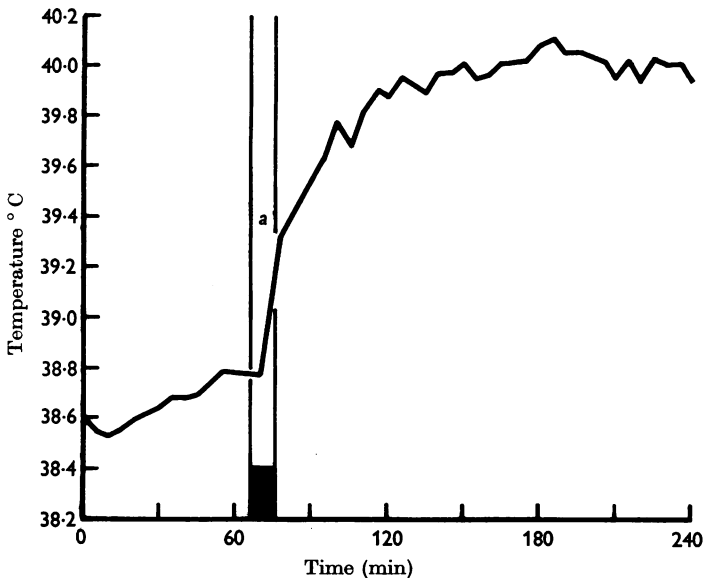

Fig. 8. Effect of an intrahypothalamic infusion of  $\text{KCl } 10.6\ \mu\text{-equiv K}^+$  given at *a* on rectal temperature.

$5.2\ \mu\text{g}$  eserine +  $13\ \mu\text{g}$  acetylcholine were infused in  $21\ \mu\text{l}$ . saline over 42 min, and neither infusion caused a significant alteration in rectal temperature. Again, a subsequent injection of endogenous pyrogen into the same site down the same cannula caused fever. One infusion of  $10.6\ \mu\text{-equiv}$  potassium chloride (given in  $4\ \mu\text{l}$ . over 10 min) into the hypothalamus caused an immediate fever, the rectal temperature rising to a maximum of  $1.3^{\circ}\text{C}$  above the control level, and the animal became restless (Fig. 8). Normal saline, plasma and rabbit c.s.f. ( $2\text{--}10\ \mu\text{l}$ .) have all been injected into the hypothalamus without effect on the body temperature.

*Evidence that the fever induced by noradrenaline was due to a central action.* Noradrenaline given into the lateral ventricle or hypothalamus

caused fever accompanied by vasoconstriction in the normal ear, but not in the sympathectomized ear (Fig. 6).

In one experiment, an intravenous infusion of 15  $\mu\text{g}/\text{min}$  of noradrenaline over 18 min did not alter the animal's rectal temperature. In another experiment, an intravenous infusion of phentolamine (0.8 mg over 10 min) did not alter the rectal temperature changes induced by noradrenaline given into the hypothalamus.

#### DISCUSSION

Three facts emerged from this study. First, that leucocyte pyrogen injected into the hypothalamus and bacterial pyrogen injected into the lateral ventricle of the rabbit both caused fever. Secondly, that noradrenaline given either into the lateral cerebral ventricle or the anterior hypothalamus sometimes caused a rise in body temperature and at other times was without effect. Thirdly that 5-HT usually caused a fall in body temperature when injected into the lateral ventricle, was without effect in the hypothalamus at normal body temperature, but during fever caused a fall in rectal temperature; and that if no response to these substances occurred, leucocyte pyrogen injected into the same sites down the same cannula invariably caused fever. The positive results obtained are in the opposite direction from those found by Feldberg & Myers (1963, 1965) in the cat. J. Bligh (personal communication) has observed the effects of these substances injected into the lateral cerebral ventricle of the sheep in which noradrenaline caused a rise and 5-HT a fall in body temperature. This seems to be a genuine species difference. Other species differences such as cholinergic innervation of human sweat glands and adrenergic innervation of horse sweat glands are well known.

That the pyrogenic effect of noradrenaline produced in the rabbit was due to a central action rather than to the peripheral action of the drug absorbed into the blood stream is clear from three lines of evidence:

(1) The changes in ear temperature accompanying the onset of fever did not occur in the sympathectomized ear.

(2) Large doses of noradrenaline (15  $\mu\text{g}/\text{min}$ ) intravenously did not cause fever and,

(3) The febrile response was not reversed by intravenous infusion of phentolamine (0.8 mg in 10 min).

Failures to induce changes in body temperature by giving noradrenaline or 5-HT into the brain were always followed by febrile responses to endogenous pyrogen given into the same site. This at first sight might seem to indicate that the amines had been infused into a site in which they were capable of influencing the neurones affecting body temperature. The relative differences in diffusion distances, tissue fixation and local

destruction between the amines and leucocyte pyrogen are not known; but they could make the exact site of the injection of the amines most critical. Our previous experiments (Cooper & Cranston, unpublished) suggest that the site at which an injection of endogenous pyrogen causes fever is sharply localized in the anterior hypothalamus and near the wall of the 3rd ventricle.

The doses of amines infused were large, and at times greater than the likely content of the whole hypothalamus. The responses might be regarded either as non-physiological high dosage effects, or alternatively the amounts infused might be necessary in order to activate a sufficiently large number of dispersed specialized receptor sites.

There are three hypotheses which could be suggested on the observed facts. First, that noradrenaline and 5-HT are transmitter substances used in some synapses in the thermoregulatory system. The argument that these substances are naturally present in the hypothalamus in large amounts, and that responses to them cause opposite effects on body temperature, is inadequate to substantiate such a theory. There is, however, morphological evidence which strongly suggests that noradrenaline may play a transmitter role in the rabbit (Carlsson *et al.* 1962). The noradrenaline within fine fibres or nerve terminals is spread mainly through the pre-optic region, the supra-optic nuclei and the paraventricular nuclei, the walls of the third ventricle, and scattered elsewhere in the anterior hypothalamus. Its distribution ranges then through regions subserving several functions. If the amines are the thermoregulatory synaptic transmitters this would be an extremely important addition to our knowledge. The second hypothesis would suggest that thermosensitive elements are neurosecretory, some secreting 5-HT and others noradrenaline, and that the interstitial proportions of these amines determine the activity of efferent neurones in the thermoregulatory system. There is no objective evidence to support this concept. The third hypothesis would suggest that the injected amines can act on the efferent neurones of the thermoregulatory system that produce opposite responses in body temperature, but are not necessarily concerned in the normal regulating system. That potassium, which presumably depolarizes all the cells and fibres that it reaches, does induce fever, suggests that this can happen, but then we are still left without an explanation of the significance of the high noradrenaline and 5-HT content of the hypothalamus. Acetylcholine and histamine, which are also present in the hypothalamus, do not appear to evoke thermoregulatory responses when injected into this region.

Pyrogens, given in large doses intravenously, are known to increase the diffusion of protein-bound dyes into the brain substance. It is possible that they might cause fever by allowing substances from cerebrospinal

fluid or plasma, which are normally excluded from the hypothalamus, to enter it. This is unlikely to be true because c.s.f. and plasma are without effect on temperature when injected into the anterior hypothalamus, though the single injection of plasma might not deliver a quantity of such a substance in an amount comparable with that delivered by a continuous flow of blood through an abnormally permeable region.

#### SUMMARY

1. Noradrenaline, when injected into the lateral ventricles or the anterior hypothalamus of the conscious rabbit, either caused a rise in body temperature or had no effect.

2. 5-HT, when similarly injected, either caused a fall in body temperature or had no effect. When the injection was into the anterior hypothalamus, it was effective only if fever had been previously induced by injection of pyrogen or noradrenaline at the same site.

3. Whenever intracranial noradrenaline or 5-HT failed to alter body temperature, an injection of either bacterial or leucocyte pyrogen into the same site caused fever.

4. These responses of the rabbit are opposite to those found by Feldberg and Myers in the cat.

5. Intrahypothalamic injection of potassium chloride caused a rise in body temperature. Histamine, acetylcholine, eserine, c.s.f. and plasma had no effect.

The authors would like to thank Sir George Pickering for his continued advice and encouragement, Miss Ann Jarvis and Miss Vivienne Darby for their technical assistance, and Mr B. A. Stone who constructed the stereotaxic equipment. Dr H. Blaschko very kindly assayed our 5-HT stock.

#### REFERENCES

- AMIN, A. N., CRAWFORD, T. B. B. & GADDUM, J. H. (1954). The distribution of substance P and 5-hydroxytryptamine in the central nervous system of the dog. *J. Physiol.* **126**, 596-618.
- ATKINS, E. (1960). Pathogenesis of fever. *Physiol. Rev.* **40**, 580-646.
- BERTLER, Å. (1961). Occurrence and localization of catechol amines in the human brain. *Acta physiol. scand.* **51**, 97-107.
- BRODIE, B. B. & SHORE, P. A. (1957). A concept for a role of serotonin and norepinephrine as chemical mediators in the brain. *Ann. N.Y. Acad. Sci.* **66**, 631-642.
- CARLSSON, A., FALCK, B., HILLARP, N. & TORP, A. (1962). Histochemical localization at the cellular level of hypothalamic noradrenaline. *Acta physiol. scand.* **54**, 385-386.
- EULER, C. VON (1961). Physiology and pharmacology of temperature regulation. *Pharmaz. Rev.* **13**, 361-398.
- FELDBERG, W. (1926). The peripheral innervation of the vessels of the external ear of the rabbit. *J. Physiol.* **61**, 518-529.
- FELDBERG, W. & MYERS, R. D. (1963). A new concept of temperature regulation by amines in the hypothalamus. *Nature, Lond.*, **200**, 1325.
- FELDBERG, W. & MYERS, R. D. (1964). Effects on temperature of amines injected into the cerebral ventricles. A new concept of temperature regulation. *J. Physiol.* **173**, 226-236.

- FELDBERG, W. & MYERS, R. D. (1965). Changes in temperature produced by micro-injections of amines into the anterior hypothalamus of the cat. *J. Physiol.* **177**, 239-245.
- FESSLER, J. H., COOPER, K. E., CRANSTON, W. I. & VOLLUM, R. L. (1961). Observations on the production of pyrogenic substances by rabbit and human leucocytes. *J. exp. Med.* **113**, 1127-1140.
- HARDY, J. (1961). Physiology of temperature regulation. *Physiol. Rev.* **41**, 521-606.
- HESS, W. R. (1932). *Die Methodik der lokalisierten Reizung und Ausschaltung subkortikalem Hirnabschnitte*. Leipzig: Georg Thieme Verlag.
- MONNIER, M. & GANGLOFF, H. (1961). *Atlas for Stereotaxic Brain Research on the Conscious Rabbit*. London: Elsevier.
- VOGT, M. (1954). The concentration of sympathin in different parts of the central nervous system under normal conditions and after the administration of drugs. *J. Physiol.* **123**, 451-481.