

Glycerol as a Correlate of Impaired Glucose Tolerance: Dissection of a Complex System by Use of a Simple Genetic Trait

Daniel Gaudet,^{1,2} Steve Arsenault,¹ Louis Pérusse,³ Marie-Claude Vohl,^{1,2} Julie St.-Pierre,^{1,2} Jean Bergeron,² Jean-Pierre Després,² Ken Dewar,⁴ Mark J. Daly,⁴ Tom Hudson,^{4,5} and John D. Rioux⁴

¹Lipid Research Group, Chicoutimi Hospital, Chicoutimi, and ²Lipid Research Center and ³Physical Activity Sciences Laboratory, Laval University, Quebec; ⁴Whitehead Institute/MIT, Center for Genome Research, Cambridge; and ⁵Montreal General Hospital Research Institute, McGill University, Montreal

Glycerol kinase (GK) represents the primary entry of glycerol into glucose and triglyceride metabolism. Impaired glucose tolerance (IGT) and hypertriglyceridemia are associated with an increased risk of diabetes mellitus and cardiovascular disease. The relationship between glycerol and the risk of IGT, however, is poorly understood. We therefore undertook the study of fasting plasma glycerol levels in a cohort of 1,056 unrelated men and women of French-Canadian descent. Family screening in the initial cohort identified 18 men from five families with severe hyperglycerolemia (values above 2.0 mmol/liter) and demonstrated an X-linked pattern of inheritance. Linkage analysis of the data from 12 microsatellite markers surrounding the Xp21.3 GK gene resulted in a peak LOD score of 3.46, centered around marker DXS8039. In addition, since all of the families originated in a population with a proven founder effect—the Saguenay Lac-St.-Jean region of Quebec—a common disease haplotype was sought. Indeed, a six-marker haplotype extending over a region of 5.5 cM was observed in all families. Resequencing of the GK gene in family members led to the discovery of a N288D missense mutation in exon 10, which resulted in the substitution of a highly conserved asparagine residue by a negatively charged aspartic acid. Although patients with the N288D mutation suffered from severe hyperglycerolemia, they were apparently otherwise healthy. The phenotypic analysis of the family members, however, showed that glycerol levels correlated with impaired glucose metabolism and body-fat distribution. We subsequently noted a substantial variation in glycerolemia in subjects of the initial cohort with normal plasma glycerol levels and demonstrated that this variance showed significant family resemblance. These results suggest a potentially important genetic connection between fasting glycerolemia and glucose homeostasis, not only in this X-linked deficiency but, potentially, in individuals within the “normal” range of plasma glycerol concentrations.

Introduction

Glycerol is an important intermediate of glucose and lipid metabolism by virtue of its ability to support glycogenesis in various systems, as well as serving as a precursor for the synthesis of triglycerides (TG) and other glycerolipids (Rognstad et al. 1974; Baba et al. 1995; McCabe 1995). Oral administration of glycerol has been demonstrated to result in increased serum glucose levels, gluconeogenesis, or both (Catron and Lewis 1929; Sommer et al. 1993), similar to the changes observed in var-

ious pathological situations such as type 2 diabetes mellitus (DM) (MIM 125853). It has also been shown that obese subjects have increased levels of plasma glycerol and increased glycerol turnover when compared with lean individuals (Chakrabarty et al. 1984; Jansson et al. 1992). These observations indicate the potential importance of glycerol homeostasis in healthy individuals, as well as in patients with abnormalities in glucose or lipid metabolism who are at higher risk of DM or coronary artery disease.

The glycerol kinase (GK) enzyme is a primary candidate for the control of glycerol levels, since it constitutes glycerol's entry into metabolic pathways. Genetic abnormalities involving the GK gene, which is located on chromosome Xp21.3 (Davies et al. 1988; Guo et al. 1993; Walker et al. 1993), have been classified as either complex or isolated deficiencies. The complex GK deficiency (GKD) is a contiguous-gene syndrome involving the GK locus, as well as the Duchenne muscular dystrophy (MIM 310200) gene locus, the adrenal hypoplasia congenita (MIM 300200) gene locus (McCabe

Received November 30, 1999; accepted for publication February 9, 2000; electronically published March 27, 2000.

Addresses for correspondence and reprints: Dr. Daniel Gaudet, Lipid Research Group, Lipid Clinic, Chicoutimi Hospital, 305 St.-Vallier Street, Chicoutimi, Quebec G7H 5H6, Canada. E-mail: dgaudet@saglac.qc.ca. Dr. John D. Rioux, Whitehead Institute/MIT Center for Genome Research, One Kendall Square, Building 300, Cambridge, MA 02139-1561. E-mail: rioux@genome.wi.mit.edu

© 2000 by The American Society of Human Genetics. All rights reserved. 0002-9297/2000/6605-0011\$02.00

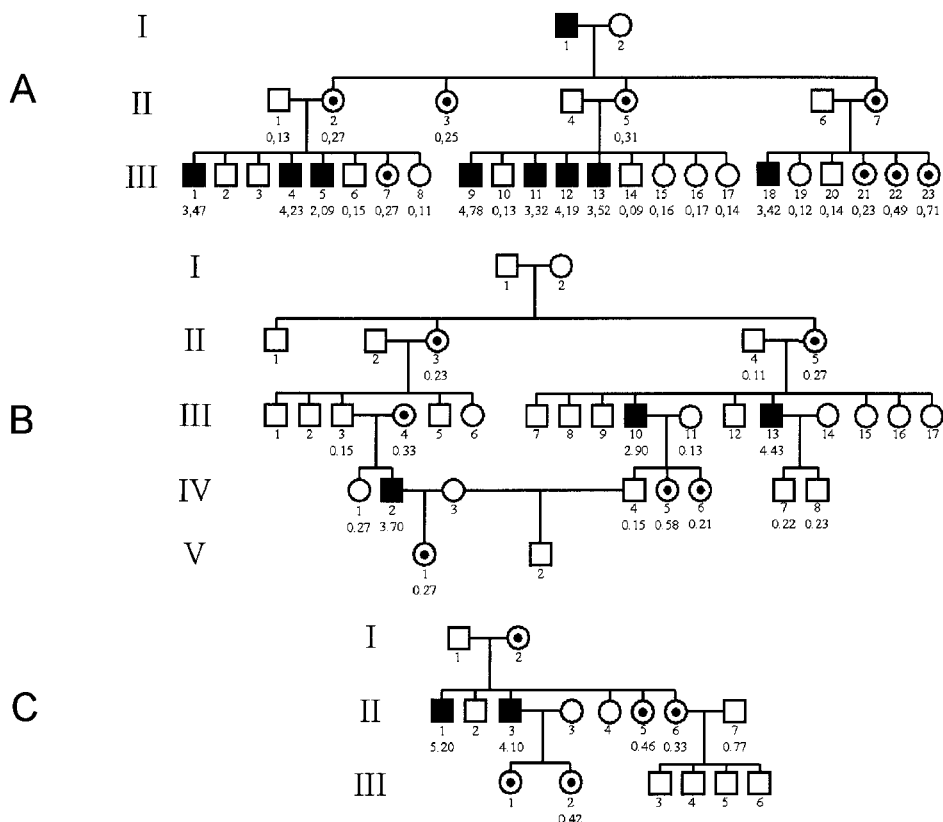

Figure 1 Pedigree drawings of three of the families whose members have severe hyperglycerolemia. Women (*dotted circles*) and men (*blackened squares*) with elevated plasma glycerol levels are indicated. The number under each symbol is the individual's identification number, and the numbers below those are the plasma glycerol levels (mmol/liter), where available.

1995), or both. In contrast, isolated GKD, which includes juvenile and adult forms, results from either point mutations or small rearrangements within the GK gene (McCabe 1995). The adult form is characterized by a phenotype of hyperglycerolemia (MIM 307030), often detected as a pseudohypertriglyceridemia, since the enzymatic measurement of TG is generally inferred from that of glycerol generated as a product of a lipolysis reaction. Apart from pseudohypertriglyceridemia, however, the clinical expression of the adult form of isolated GKD is not well documented, mainly because of the small number of clinically and genetically heterogeneous families described in previous reports (Rose and Haines 1978; Blomquist et al. 1996; Walker et al. 1996; Romero et al. 1997; Sjarif et al. 1998). None of these studies was designed to examine—or had the power to examine—the broader metabolic implications of raised plasma glycerol levels in the fasting state. In the present study, we report the findings of our clinical and molecular genetic examinations of the largest group of individuals with familial hyperglycerolemia ever reported. These individuals were identified from a cohort of 1,056 unrelated French Canadians. We provide evidence that

fasting glycerolemia is a significant predictor of impaired glucose tolerance (IGT) in these families whose members have hyperglycerolemia, and we propose a potentially important genetic connection between glycerol and glucose homeostasis, even in what is considered as the normal range of plasma glycerol concentration.

Subjects and Methods

Subjects

From a large sample of 1,056 individuals of French-Canadian descent aged ≥ 18 years screened for plasma glycerol concentration, 5 men presented with plasma glycerol values >2.0 mmol/liter. Screening of their families identified a total of 18 men demonstrating extremely elevated plasma glycerol levels (range 2.9–6.2 mmol/liter). In addition, 14 obligate female carriers were found to be dysglycerolemic, presenting intermediate plasma glycerol levels of 0.21–0.82 mmol/liter, whereas all other family members showed plasma glycerol concentrations <0.2 mmol/liter. On the basis of the pedigree data shown in figure 1, it was clear that the severe hyperglycerolemia

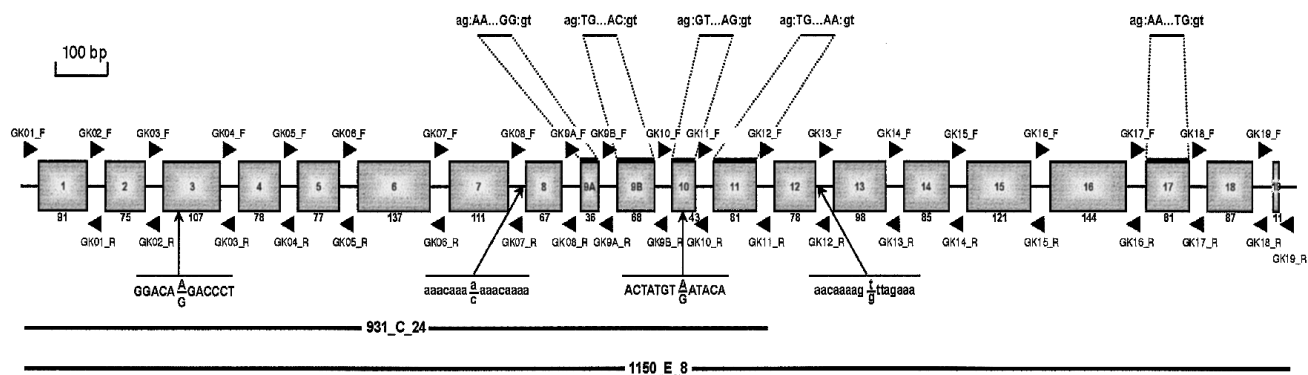

Figure 2 The exonic structure of the Xp GK gene and location of sequence polymorphisms and N288D mutation. Boxes show each exon and its length in base pairs (intron length not drawn to scale). Primers used to amplify each exon are shown over and under the exonic structure (*arrowheads*). The updated exon-intron boundaries of exons 9, 10, 11, and 17 are shown in the upper part of the diagram, with uppercase letters indicating exons and lowercase letters indicating introns. The two PAC clones used for the genomic structure determination are illustrated by the two lines at the bottom of the figure. All details regarding primer sequences and annealing temperatures are available on the Chicoutimi Hospital Lipid Research Group and Whitehead Institute/MIT Center for Genome Research GK Web sites.

phenotype segregated as a simple X-linked trait. All participants in the present study gave written informed consent. This project received the approval of the Chicoutimi Hospital Ethics Committee.

Linkage to the Xp21.3 Locus

Genomic DNA was obtained from peripheral blood lymphocytes for the genotyping of 13 affected men, 5 obligate female carriers, and 23 relatives from the families of the probands with severe hyperglycerolemia. A total of 12 microsatellite markers in the region of the GK gene were genotyped in these five families. The markers were as follows, in order: DXS989, DXS8039, DXS1214, DXS1036, DXS1067, DXS1219, DXS997, DXS8090, DXS8025, DXS8113, DXS8042, and DXS8012. Genotypes for these markers were obtained by PCR with fluorescently labeled primers. Each locus was amplified separately, and the individual PCR products were then multiplexed into panels by pooling on the basis of allele size range and fluorescent label. Aliquots of the multiplexed samples were mixed with either Tamra-labeled GENESCAN 500 and GENESCAN 2500 (PE Applied BioSystems) or rhodamine-labeled MapMarkers (Bioventures) prior to electrophoresis on ABI 377 sequencers (PE Applied BioSystems). The genotyping gels were analyzed in an automated system developed at the Whitehead Institute/MIT Center for Genome Research, as described elsewhere (Rioux et al. 1998).

Genomic Structure of the GK Gene

Genomic sequences were sought for the intronic regions surrounding exons 9, 10, 11, and 17. P1 artificial chromosome (PAC) clone RPCI-5.931_C_24 containing exons 9, 10, and 11 was identified by use of primer pairs

GK08 and GK12. PAC clone RPCI-5.1150_E_8 containing exon 17 was identified by use of primers GK17F and GK17R. Direct sequencing of introns 9 and 10 from clone RPCI-5.931_C_24 by means of specific exonic primers (GK9F, GK10F, and GK10R) was carried out with the Big Dye terminator cycle sequencing kit (PE Applied BioSystems) under the following conditions: denaturation at 95°C for 5 min, then 95°C for 30 s, 50°C for 20 s, and 60°C for 4 min, for 100 cycles.

To obtain the genomic sequence for intron 17, a single colony of clone RPCI-5.1150_E_8 was diluted in 100 μ l of water and was used as template for PCR amplification. An amplicon covering exon 17 through exon 18 was obtained with primers GK17_F and GK18_R (fig. 2) with Platinum *Taq* High Fidelity (Life Technologies). The PCR product was purified by the solid-phase reversible immobilization method (Hawkins et al. 1994) and then sequenced with the DYEnamic Energy Transfer primer kit (Amersham Pharmacia Biotech).

All sequencing reactions were run on ABI377 automated sequencers (PE Applied BioSystems); the gel files were processed by the BASS and Trout software (available on the Whitehead Institute/MIT Center for Genome Research FTP site) and then were assembled and analyzed with the use of the Staden (GAP4) software package (Staden 1996). All details regarding primer sequences and annealing temperatures are available on the Chicoutimi Hospital Lipid Research Group and Whitehead Institute/MIT Center for Genome Research GK Web sites.

GK Mutation Screening

The screening for mutations in the GK gene was first performed by resequencing this gene in nine affected individuals, four obligate carriers, and three unaffected

relatives from the five families described above. Intronic primers used were previously published (Sargent et al. 1994) or designed from the sequence determined in the present study with the use of the Primer 3.0 software, which is available on the Whitehead Institute/MIT Center for Genome Research server. Sequencing reactions with the DYEnamic Energy Transfer primer kit were performed and analyzed as described above. Regions in which sequence polymorphisms were discovered were resequenced in 9 other affected individuals, 10 obligate carriers, unaffected relatives from the GK families, and 50 independent individuals from the initial cohort as population controls.

Plasma Glycerol and Other Biological Measurements

Blood samples were drawn while the individual was at rest after a 12-h overnight fast. The blood was drawn from an antecubital vein into tubes containing EDTA. Specimens were centrifuged within 1 h, and the separated plasma was frozen (-80°C) until analysis. TG and free fatty acid (FFA) levels were measured by enzymatic assays (McNamara and Schaefer 1987). Plasma glycerol concentrations were measured with an analyzer Technicon RA-500 (Bayer Corporation), and enzymatic reagents were obtained from Randox (Randox Laboratories). Glycerol measurements were calibrated with reference standards purchased from Sigma. Intra- and interassay coefficients of variation were 1.3% and 2.5%, respectively, for levels of 0.1 mmol/liter and were 0.9% and 1.7% for levels of 1.0 mmol/liter. Waist and hip circumferences (Lohman et al. 1988), body weight, height, and body-mass index were recorded. Percentage of body fat was estimated by bioelectrical impedance (Baumgartner et al. 1990). Family history of DM was defined as the presence of a confirmed diagnosis in a first-degree relative. An oral glucose-tolerance test (OGTT) was performed in the original cohort of 1,056 individuals and in the families of the five GK carrier probands; we used a 75-g glucose load (Richterich and Dauwalder 1997), and plasma glucose concentration was enzymatically measured (Richterich and Dauwalder 1971). IGT and DM were defined according to the World Health Organization (WHO Study Group on Diabetes 1987). Fasting insulinemia was measured by radioimmunoassay with polyethylene glycol separation (Desbuquois and Aurbach 1971).

Statistical Analysis

Multipoint parametric linkage analysis was performed by the GENEHUNTER software package (Kruglyak et al. 1996). Marker order and genetic distances used in the analysis were based on an integration of the published genetic map (CEPH-Genethon Database) and radiation-hybrid mapping information obtained by the Genebridge 4 hybrid panel (Gyapay et al. 1996). On the

basis of the number of cases observed in the population, GK disease-allele frequency was estimated at .001, whereas the values for male penetrance of .999 and female penetrance of .900 and .999 (heterozygotes and homozygotes, respectively) were estimated from the family data. Group differences for plasma glycerol concentrations and other continuous variables were examined by the Student's unpaired two-tailed *t*-test. Linear regression models were used to assess the relationship between the dependent variables (2-h glucose following a 75-g oral absorption or correlates of body-fat accumulation) and fasting glycerolemia. The distribution of plasma TG and insulin levels was normalized by \log_{10} transformation. Analyses were performed by the SPSS package (release 6.1, SPSS).

After having excluded families of subjects bearing the N288D mutation, calculation of familial resemblance of plasma glycerol concentrations in the fasting state was performed for a total of 652 individuals that arose from the nuclear families of 174 randomly selected patients of the initial cohort representing all deciles of fasting glycerol values. Before analyses, glycerol data were adjusted for age by use of sex-specific regressions, and the residuals from these regressions were standardized to a mean of 0 and a standard deviation of 1. The standardized residuals were used to assess the degree of familial resemblance by computing the intraclass correlation (*r*) as previously described (Bogardus et al. 1986; Pérusse et al. 1997). This correlation was calculated by computing the ratio of the between-family variance over the sum of the within- and between-family variances estimated with a random effect model of analysis of variance (Bogardus et al. 1986).

Results

Linkage to Xp21.3 of the Severe Hyperglycerolemia Phenotype

We genotyped 12 microsatellite markers, covering ~25 cM in the region of Xp21.3, among the five pedigrees that described affected individuals. Multipoint parametric linkage analysis of the genotype data resulted in a peak LOD score of 3.46 centered at marker DXS8039, the closest marker to the GK gene. As all families originated from a population with a proven founder effect (Gradie et al. 1998), a common disease haplotype was sought. Indeed, a six-marker haplotype consisting of markers DXS8039, DXS1214, DXS1036, DXS1067, DXS1219, and DXS997 (alleles 151, 210, 145, 222, 230, and 107, respectively) was observed in all families. This haplotype extended over a region of 5.5 cM.

Genomic Structure of the GK Gene

Since the GK gene is located near the linkage peak, clearly indicating its likely involvement in this pheno-

type, we set out to obtain intronic sequences surrounding exons 9, 10, 11, and 17 to design primers to complete the set of previously reported oligonucleotides for mutation screening (Sargent et al. 1994). This sequencing led to the discovery (fig. 2) of a small intron within what had previously been described as exon 9 (Sargent et al. 1994). Specifically, we found an insert of 394 bp located after the 36th nucleotide of exon 9, suggesting that the originally described exon actually consists of two exons of 36 and 68 bases in length, respectively, that we have named 9A and 9B. This correction of the published genomic structure is supported by a recent report (Sjarif et al. 1998). In addition, when the sequence obtained for intron 10 was aligned with the published cDNA sequence, it was discovered that the splice junctions had been incorrectly defined, so that the last 12 bases of exon 10 were in fact encoded by exon 11. Furthermore, when the entire intron was sequenced, rather than being >8 kb in length, as originally believed, it was found to be 456 bp.

Identification of a Missense Mutation in Exon 10 within Families with Severe Hyperglycerolemia

All 20 GK exons and their corresponding intron-exon boundaries were screened for mutations. Four nucleotide positions were found to have sequence differences between the affected men and their unrelated control individuals, and, at these same positions, the obligate female carriers were heterozygous. Specifically, two of these sites were discovered within the introns and two within the exons (fig. 2). Neither of the intronic nucleotide changes is expected to lead to a functional difference. On the basis of the predicted amino acid sequence for this gene, the nucleotide change in exon 3 is silent, whereas the base change in exon 10 results in a missense mutation. Specifically, this latter change results in a transition of an adenine to a guanine, and this mutation (N288D) leads to the substitution of a small polar asparagine for a negatively charged aspartic acid (fig. 3). Screening of the remaining family members demonstrated that this mutation was restricted to the 18 affected men and 14 obligate female carriers and was not present in the normoglycerolemic individuals examined from the original cohort. This was not true of the other three nucleotide changes, since they were found in a sample of 50 normoglycerolemic controls at frequencies >10%. It is important to note that asparagine 288 of GK is extremely well conserved in many different species, including *Haemophilus influenzae*, *Mycoplasma pneumoniae*, *Escherichia coli*, yeast, and mouse, as well as human (fig. 3) (Pettigrew et al. 1988, 1998).

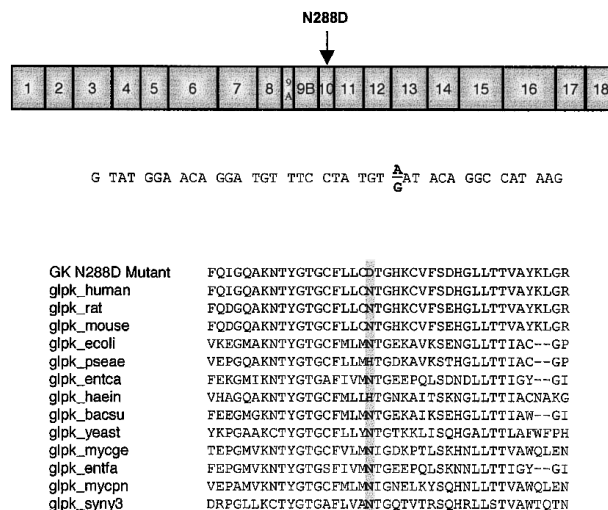

Figure 3 Alignment of the predicted amino acid sequence for the N288D mutant with the wild-type sequences from different organisms. Abbreviations: *ecoli*, *E. coli*; *pseae*, *Pseudomonas aeruginosa*; *entca*, *Enterococcus casseliflavus*; *haein*, *Haemophilus influenzae*; *bacsu*, *Bacillus subtilis*; *yeast*, *Saccharomyces cerevisiae*; *mycge*, *Mycoplasma genitalium*; *entfa*, *Enterococcus faecalis*; *mycpn*, *Mycoplasma pneumoniae*; *syny3*, *Synechocystis* PCC6803. Dashes represent gaps introduced in the sequences to maximize alignment.

Phenotypic Expression of the N288D Mutation: Association of Fasting Glycerol Concentration with IGT and Abdominal Obesity

Monitoring of plasma glycerol levels at 3–6-mo intervals in individuals with the N288D mutation demonstrated that the hyperglycerolemia was permanent, resulting in values >2.5 mmol/liter in men and >0.2 mmol/liter in women. Despite severe hyperglycerolemia, individuals with the N288D mutation were apparently healthy. In contrast to what is observed in the cases of contiguous-gene-deletion syndrome involving the GK gene, none of the hyperglycerolemic patients of the present study had evidence of muscular or adrenal involvement. Review of the medical histories did not show any previous episode of severe illness (vomiting, acidemia, stupor, or unconsciousness), as reported with the juvenile form of isolated GKD (McCabe 1995). As would be expected, the N288D carriers also showed important pseudohypertriglyceridemia when compared with unaffected relatives. Interestingly, even after correction for free glycerol, GK patients tended to remain hypertriglyceridemic (plasma TG >2.0 mmol/liter).

The 18 affected men and the 14 obligate female carriers identified were matched with unaffected relatives by age (± 5 years) and by sex; their characteristics are compared in table 1. This comparison demonstrated that the N288D mutation was associated with significantly higher body-mass index, waist circumference, and total

Table 1**Characteristics of Carriers of the N288D GK Gene Mutation and of Their Unaffected Relatives**

VARIABLE	MEN			WOMEN		
	N288D Carriers	Unaffected Relatives	<i>P</i>	N288D Carriers	Unaffected Relatives	<i>P</i>
Number	18	18		14	14	
Age (years)	46.4 ± 14.2	42.0 ± 18.8	.32	44.9 ± 13.5	43.7 ± 17.8	.87
Uncorrected triglyceride (mmol/liter) ^a	6.26 ± 1.13	2.05 ± .54	<.0001	2.84 ± 1.20	1.30 ± .65	.0002
Glycerol (mmol/liter)	3.99 ± .71	.10 ± .04	<.0001	.54 ± .14	.10 ± .02	<.0001
Corrected triglyceride (mmol/liter) ^a	2.27 ± .75	1.95 ± .53	<.0001	2.31 ± 1.22	1.19 ± .67	.03
Free fatty acid (mmol/liter)	.77 ± .22	.57 ± .25	.01	1.29 ± .35	.76 ± .17	.0004
Fasting glucose (mmol/liter)	5.2 ± .74	4.8 ± .31	.13	5.0 ± .7	4.6 ± .3	.1
2-h glucose following OGTT (mmol/liter)	7.9 ± 3.1	5.8 ± 1.6	.02	7.0 ± 6.1	5.0 ± 2.1	.04
Fasting insulin (mU/liter) ^a	13.3 ± 14.0	15.1 ± 14.8	.62	12.2 ± 13.1	9.0 ± 3.4	.6
Waist girth (cm)	97.7 ± 9.3	88.1 ± 12.3	.01	88.5 ± 3.8	79.8 ± 5.8	.03
Body mass index (kg/m ²)	27.9 ± 4.1	24.9 ± 3.9	.03	28.1 ± 5.5	23.1 ± 2.3	.001
Total body fat (%)	27.1 ± 7.2	22.9 ± 7.6	.01	46.8 ± 8.1	33.9 ± 11.3	.001

NOTE.—Values are means ± SD.

^a Geometric mean, *P* after log transformation.

body fat, increased fasting plasma FFA concentrations, and a higher mean 2-h glucose concentration following an OGTT. Furthermore, analysis of plasma glucose homeostasis, as well as anthropometric indices of abdominal obesity in men carrying a N288D mutation, showed that 12 of the 18 affected men met the criteria of either DM or IGT (fig. 4A). Among the six subjects with normal 2-h glucose levels, four men showed elevated fasting insulin values, which suggests that they were insulin resistant (data not shown). It was also observed that there were significant differences in glycerol levels among N288D bearers. As illustrated in figures 4A and 4B, these differences were shown to be important correlates of body-fat accumulation and glucose concentrations. Specifically, we observed that 68.9% of the variance in 2-h glucose values ($P < .0001$) and 45.2% of the variance in waist circumference ($P < .001$) could be explained by the variance in glycerolemia among these subjects. Compared with glycerol, variations in plasma fasting FFA or insulin concentrations explained a significantly lower proportion of the variance in 2-h glucose and in waist circumference (data not shown).

Genetic and Phenotypic Analysis of the Normoglycerolemic Population

In light of the genetic control of glycerolemia observed in the GKD families, as well as the association with IGT, analyses of the original cohort excluding the severe hyperglycerolemic individuals were also performed. Specifically, analyses of familial resemblance in the original cohort revealed that there was six times more variance in fasting plasma glycerol levels between than within families (fig. 5). If we assume that the resemblance explained by belonging to the same pedigree is entirely defined by genetic factors, the maximal heritability of

glycerolemia in the fasting state was estimated at 58% (95% confidence interval [CI] 52%–64%). In addition, as seen in the presence of the N288D GK mutation, a trend between mean glycerol concentration and the degree of glucose intolerance was observed in normoglycerolemic individuals (fig. 4C).

Discussion

It is likely that there are hundreds of different genes involved in the modulation of plasma glucose and lipid homeostasis. Among them are genes involved in the regulation of glycerol metabolism, since these pathways contribute directly or indirectly to cellular energy metabolism by providing mitochondria with substrate for oxidative phosphorylation (McCabe 1994). In this regard, GK plays a pivotal role, since it constitutes the entry of glycerol into metabolism, catalyzing the phosphorylation of glycerol by adenosine triphosphate (ATP) to yield glycerol 3-phosphate and adenosine diphosphate (McCabe 1994, 1995). Although glycerol is a well accepted indicator of lipolysis and is a gluconeogenic precursor (Rognstad et al. 1974), the relationship between glycerol and glucose homeostasis is complex and not yet completely elucidated. One way to further this knowledge is to study cases of hyperglycerolemia to establish the effect of glycerol levels in this extreme phenotype on the other metabolic pathways, and then examine whether similar effects can be found in normoglycerolemic individuals.

Following this approach, we describe here the molecular and clinical characteristics of the largest sample of individuals with familial hyperglycerolemia ever reported. Importantly, all families exhibiting this severe phenotype were identified through a systematic screen-

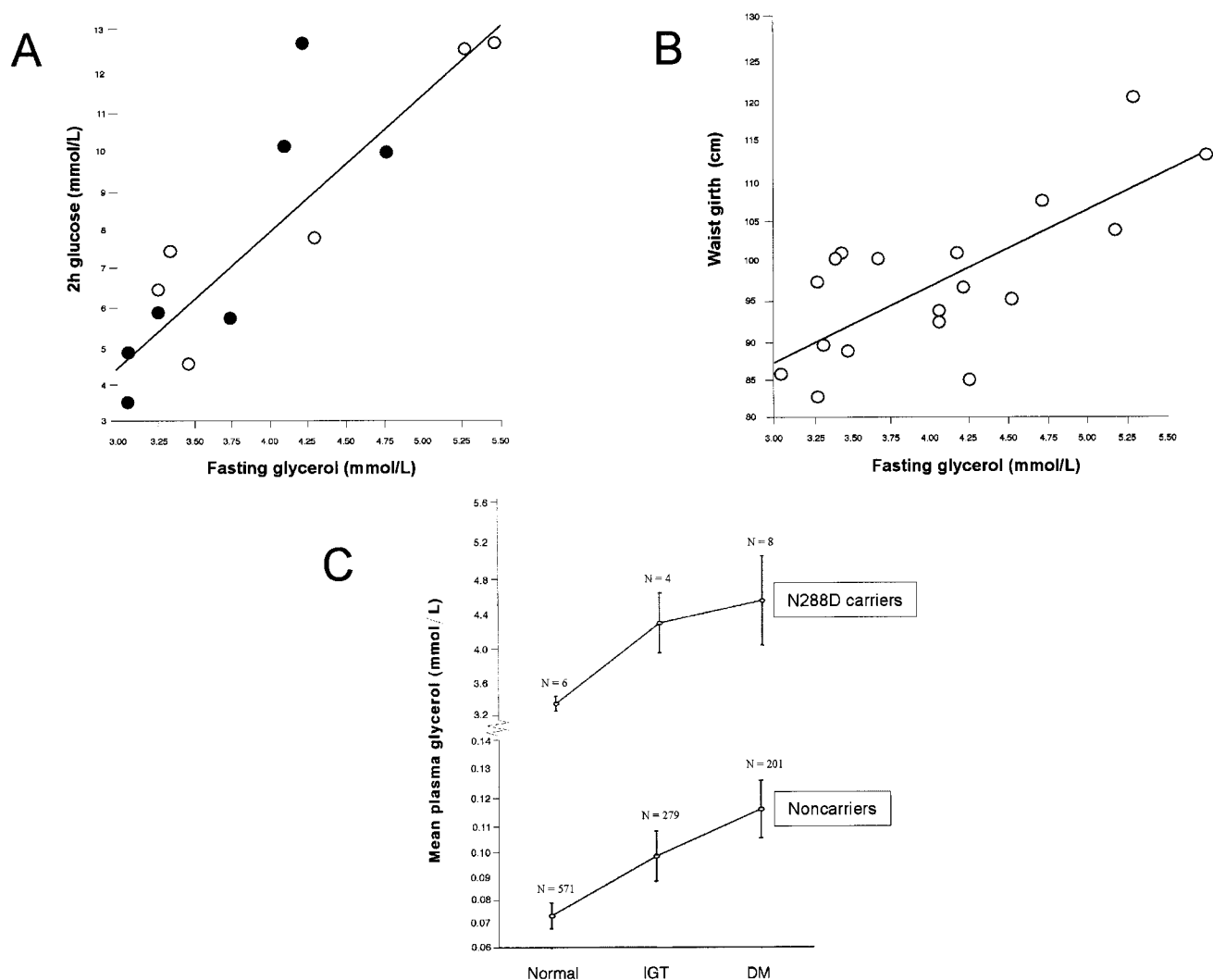

Figure 4 Association of plasma glycerol with correlates of glucose intolerance. *A, B*, Among the 18 men bearing the N288D mutation, glycerol was a significant correlate of 2-h glucose following a 75-g oral load ($r^2 = 0.689$, $P < .0001$) and waist girth ($r^2 = 0.452$, $P < .0001$). Five men with previously diagnosed DM did not undergo an OGTT. Individuals with fasting insulin concentrations above 15 mU/liter (*A*, black circles) are indicated. *C*, Mean plasma glycerol concentrations ($\pm 95\%$ CI) according to the magnitude of glucose tolerance in subjects with or without severe hyperglycerolemia due to the N288D mutation. “Normal” defines the category of subjects with normal glucose tolerance (2-h glucose < 7.8 mmol/liter following a 75-g oral glucose absorption). “IGT” identifies impaired glucose tolerance (2-h glucose 7.8–11.0 mmol/liter), whereas “DM” denotes the presence of criteria of type 2 DM (2-h glucose ≥ 11.1 mmol/liter) during the OGTT. The ratio of normal/IGT/DM in N288D individuals was significantly different from that of noncarriers ($\chi^2 = 14.3$; $P = .001$).

ing of fasting glycerol levels in a large number of individuals of French-Canadian descent. The homogeneity of this group of patients is clearly demonstrated by our observation that all affected individuals bear the same N288D mutation in the GK gene, present on a haplotype that is common to all GKD families. The study of this rare deficiency in glycerol metabolism demonstrated that although all individuals bearing the N288D mutation were hyperglycerolemic, significant interindividual variations in glycerolemia were observed, and these differences were found to explain an

important part of the variance observed in glucose tolerance and abdominal obesity—a feature not reported in previous studies on familial hyperglycerolemia.

The mechanisms by which the N288D mutation could result in hyperglycerolemia remain to be elucidated. GK, also known as ATP:glycerol 3-phosphotransferase, is a member of the sugar kinase–heat shock 70–actin superfamily of enzymes (Pettigrew et al. 1988). The defined structure for the members of this superfamily consists of a deep and narrow cleft, the enzymatic active site, that separates two large domains (Pettigrew

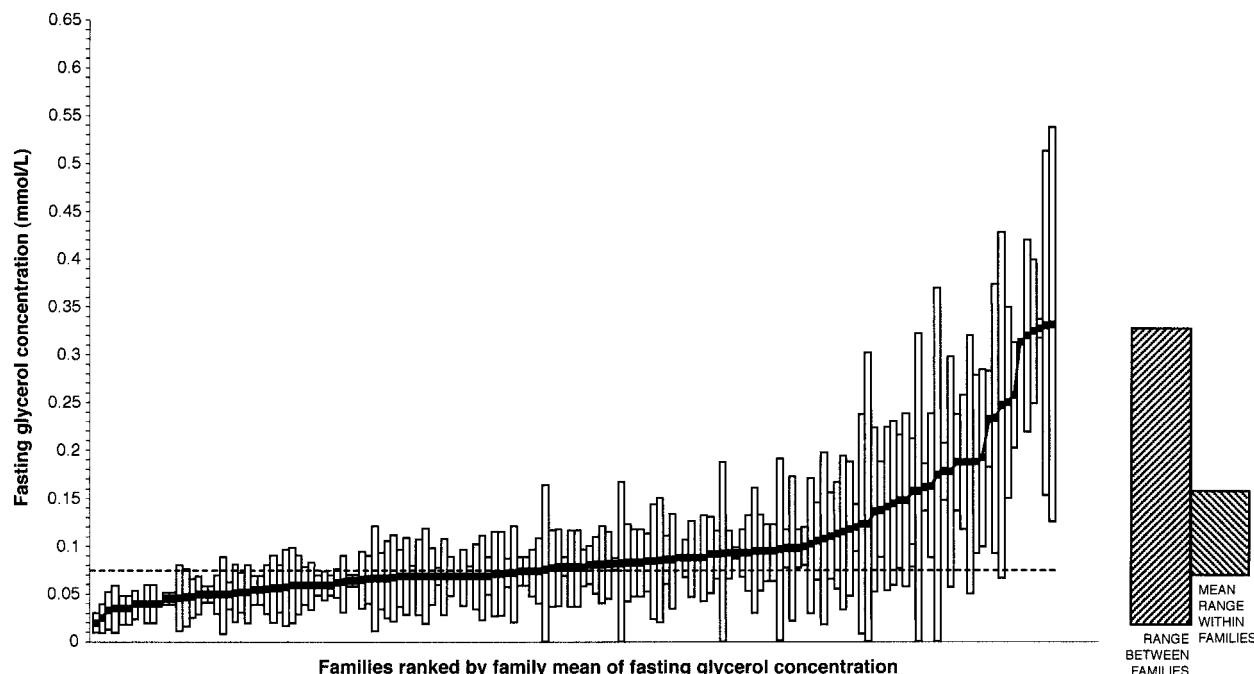

Figure 5 Familial resemblance of plasma glycerol concentrations in the fasting state. One hundred seventy-four individuals were randomly selected from the initial cohort of 1,056 individuals. Analyses were performed on these individuals and their family members after we excluded families who showed evidence of X-linked transmission of hyperglycerolemia caused by the N288D mutation in the GK gene. The families are ranked according to plasma glycerol concentration in the fasting state. The range of mean glycerolemia between and within families is shown (*hatched bars, right*). In the absence of GK gene mutation, a highly significant ($P < .0001$) F ratio of 6.3 was observed, suggesting that there is over six times more variance between families than within them for plasma glycerol levels in the fasting state. The maximal heritability of glycerolemia in the fasting state has been estimated at 58% (95% CI 52%–64%) in the absence of severe hyperglycerolemia. The dashed line denotes median and geometric mean of plasma glycerol concentration (0.075 mmol/liter) observed in the initial cohort of 1,056 individuals (the probands).

et al. 1988). These large domains are subdivided into subdomains; the two subdomains that are topologically identical to the common ATP core of hexokinase are termed IA and IIA. Asparagine 274 in the GK enzyme of *E. coli*, the residue corresponding to asparagine 288 in humans, is located in subdomain IIA (Pettigrew et al. 1988). Although this residue is not believed to be directly involved in the catalytic site, since it has no direct contact with either the glycerol or ATP molecules, it is possible that the change to a negatively charged aspartic acid in our GKD patients could alter the structure of subdomain IIA. Indeed, it is believed that enzymatic activity is coupled to a conformational change in which the two domains close around the ATP molecule (Pettigrew et al. 1998). Specifically, the change from an uncharged asparagine residue to a negatively charged aspartate could possibly impede the domain closure central to the catalytic mechanism.

Following the findings in the severe hyperglycerolemic families, examination of the large cohort of normoglycerolemic individuals suggested that fasting plasma glycerol concentrations have an important familial component in humans. This finding is potentially

important, since glycerol is usually only considered as an intermediate metabolite, its concentration being affected by multiple factors such as the degree of glycerol released by lipolysis, the rate of glycogenesis or glycogenolysis, obesity, starvation, exercise, the use of pharmaceutical preparations, and numerous pathological conditions (Frank et al. 1981; Sommer et al. 1993; McCabe 1995). Despite the variety of environmental factors affecting glycerol concentrations, we found that the heritability of fasting glycerolemia could be as high as 58% in humans. This indicates an important genetic control of glycerol levels in the normal population. Moreover, the trend observed between mean glycerol concentration, the waist girth, and the degree of glucose intolerance suggests that the genetic control of glycerol levels may potentially have a role to play in glucose and fat metabolism. Although the N288D is unlikely to play a role in the general population (it was not present in any of the normoglycerolemic individuals we tested), we would postulate that it is likely there are common genetic variants in the glycerol metabolic pathway affecting glucose and fat homeostasis.

Overall, numerous factors favor the possibility of a

causative association between glycerol and fat metabolism (Rognstad et al. 1974; Chakrabarty et al. 1984; Baba et al. 1995; McCabe 1995). Indeed, studies in lean and obese subjects showed that there was a direct correlation between plasma glycerol concentration and glycerol turnover, and that both were increased in obese subjects when compared with lean individuals (Chakrabarty et al. 1984). In another interesting study, Huq et al. (1997) have generated GK-deficient mice by gene targeting. In their study, mutant male mice appeared normal at birth and exhibited severe hyperglycerolemia with altered fat metabolism and elevated FFA concentrations. However, this model was probably closer to the human complex GKD phenotype, since GK-deficient male mice showed postnatal growth retardation, autonomous glucocorticoid synthesis, and death by 3–4 d of age, whereas heterozygous female individuals were healthy and biochemically normal.

The possibility of a causative association between glycerol and glucose metabolism is also supported by several factors, including the fact that glycerol is an important glucose precursor (Baba et al. 1995). It is likely that the mechanisms involved in the glycerol-derived gluconeogenesis increase are the result of accelerated lipolysis, as well as of altered intrahepatic handling of glycerol (Yilmaz et al. 1987). In a recent study that used a rat model, the gene encoding the bacterial form of GK has been introduced in beta cells of islets of Langerhans by use of adenovirus systems (Noel et al. 1997). The results showed that glycerol appeared to be a highly effective insulin modulator. However, it is not clear if human beta cells exhibit sufficient GK activity to allow significant metabolism of the substrate (Noel et al. 1997). In another interesting study, Yang et al. (1999) have observed that glycerol activates glucose-responsive neurons by using a regulatory mechanism similar to that of pancreatic beta cells and could therefore act indirectly as an hypothalamic glucose sensor. These data suggest that beyond glycerol-derived gluconeogenesis, glycerol is likely to play a fine regulatory role (Huq et al. 1997; Eto et al. 1999; Yang et al. 1999). In this regard, glycerolemia turned out to be a better predictor of 2-h glucose than FFAs or insulinemia in carriers of mutation N288D. Although quite convincing, the positive relation between glycerol and 2-h glucose observed in N288D carriers is made on the basis of clinical data only and the possibility of a causative association between the N288D GK variant and 2-h glucose would be better supported by direct kinetic assessment of the effect of the mutation and transfection of the amino acid substitution into tissue-culture cells. Furthermore, the notion whether the association of glycerol with IGT is independent of variations in other covariates such as insulinemia, FFAs, or anthropometric

variables remains to be verified in a larger cohort, representative of individuals with normal glycerolemia.

In conclusion, the current study of a large sample of unrelated individuals and of a homogeneous group of patients with a rare deficiency in glycerol metabolism suggests an important genetic connection between glycerol metabolism and the level of glucose tolerance. Indeed, familial resemblance of glycerol levels suggests that there likely exist common genetic factors in the general population that would explain some of the differences in plasma glycerol levels. It will thus be important to find the common allelic variants and their functional consequences in GK and the other genes involved in the glucose and lipid metabolic pathways, in order to better understand the various processes that determine the body's ability to regulate blood glucose as well as body-fat accumulation and distribution.

Acknowledgments

We would like to thank Denise Morin, Nadia Mior, Ruth St.-Gelais, Lyne Coté, Jocelyne Delisle, and Céline Bélanger from the Chicoutimi Hospital Lipid Research Group (GRID), Ugo Ogwudu and Wen Juan Ye from the Whitehead Institute (MIT), and Alain Houde from the Lipid Research Center in Quebec City for their technical assistance. We would also like to thank Drs. E. S. Lander, D. Altshuler, and J. Hirschorn for helpful discussions during the preparation of this manuscript. We received grants from Bristol-Myers Squibb Company, Afymetrix, Millennium Pharmaceuticals, Fonds de la Recherche en Santé du Québec, and Hydro-Québec. M. C. V. and T. J. H. are recipients of a fellowship and a Clinician Scientist Award, respectively, from the Medical Research Council of Canada. J. S.-P. is a recipient of a doctoral award from the Heart and Stroke Foundation of Canada and the Medical Research Council of Canada. We dedicate this work to Dr. Sital Moorjani, who passed away during the planning stages of this study.

Electronic-Database Information

Accession numbers and URLs for data in this article are as follows:

Lipimed site, <http://www.lipimed.com/gk/> (GK project; for information on the primers used and the newly described sequence)

Online Mendelian Inheritance in Man (OMIM), <http://www.ncbi.nlm.nih.gov/Omim> (for DM, type 2 [MIM 125853], hyperglycerolemia [MIM 307030], adrenal hypoplasia [MIM 300200], and muscular dystrophy [MIM 310200])

Whitehead Institute/MIT Center for Genome Research, <http://www.genome.wi.mit.edu/cgi-bin/primer/primer3.cgi> (for Primer 3.0 software)

Whitehead Institute/MIT Center for Genome Research, <http://www.genome.wi.mit.edu/ftp/distribution/software/> (for BASS/GRACE gel analysis system)

Whitehead Institute/MIT Center for Genome Research, <http://>

/www.genome.wi.mit.edu/~mjdaly (for GENEHUNTER program for linkage and TROUT program for sequence analysis)

Whitehead Institute/MIT Center for Genome Research, GK project, <http://www.genome.wi.mit.edu/humgen/projects/gk.html> (for information on the primers used and newly described sequence)

References

- Baba H, Zhang X-J, Wolfe RR (1995) Glycerol gluconeogenesis in fasting humans. *Nutrition* 11:149–153
- Baumgartner RN, Chumlea WC, Roche AF (1990) Bioelectric impedance for body composition. *Exerc Sport Sci Rev* 18:193–224
- Blomquist HK, Dahl N, Gustafsson L, Hellerud C, Holme E, Holmgren G, Matsson L, et al (1996) Glycerol kinase deficiency in two brothers with and without clinical manifestations. *Clin Genet* 50:375–379
- Bogardus C, Lillioja S, Ravussin E, Abbott W, Zawadzki JK, Young A, Knowler WC, et al (1986) Familial dependence of the resting metabolic rate. *N Engl J Med* 315:96–100
- Catron LF, Lewis HB (1929) The formation of glycogen in the liver of the young white rat after the oral administration of glycerol. *J Biol Chem* 84:553–559
- Chakrabarty K, Tauber JW, Sigel B, Bombeck CT, Jeffay H (1984) Glycerokinase activity in human adipose tissue as related to obesity. *Int J Obes* 8:609–622
- Davies KE, Patterson MN, Kenwick SJ, Bell MV, Sloan HR, Westman JA, Elsas LJ 2d, et al (1988) Fine mapping of glycerol kinase deficiency and congenital adrenal hypoplasia within Xp21 on the short arm of the human X chromosome. *Am J Med Genet* 29:557–564
- Desbuquois B, Aurbach GD (1971) Use of polyethylene glycol to separate free and antibody-bound peptide hormones in radioimmunoassays. *J Clin Endocrinol Metab* 33:732–738
- Eto K, Tsubamoto Y, Terauchi Y, Sugiyama T, Kishimoto T, Takahashi N, Yamauchi N, et al (1999) Role of NADH shuttle system in glucose-induced activation of mitochondrial metabolism and insulin secretion. *Science* 283:981–985
- Frank MSB, Nahata MC, Hilty MD (1981) Glycerol: a review of its pharmacology, pharmacokinetics, adverse reactions, and clinical use. *Pharmacotherapy* 1:147–160
- Gradie MI, Jorde LB, Bouchard G (1988) Genetic structure of the Saguenay, 1852–1911: evidence from migration and isonymy matrices. *Am J Phys Anthropol* 77:321–333
- Guo W, Worley K, Adams V, Mason J, Sylvester-Jackson D, Zhang YH, Towbin JA, et al (1993) Genomic scanning for expressed sequences in Xp21 identifies the glycerol kinase gene. *Nat Genet* 4:367–372
- Gyapay G, Schmitt K, Fizames C, Jones H, Vega-Czarny N, Spillett D, Muselet D, et al (1996) A radiation hybrid map of the human genome. *Hum Mol Genet* 5:339–346
- Hawkins TL, O'Connor-Morin T, Roy A, Santillan C (1994) DNA purification and isolation using a solid phase. *Nucleic Acids Res* 22:4543–4544
- Huq AH, Lovell RS, Ou CN, Beaudet AL, Craigen WJ (1997) X-linked glycerol kinase deficiency in the mouse leads to growth retardation, altered fat metabolism, autonomous glucocorticoid secretion and neonatal death. *Hum Mol Genet* 6:1803–1809
- Jansson PA, Larsson A, Smith U, Lonroth P (1992) Glycerol production in subcutaneous adipose tissue in lean and obese humans. *J Clin Invest* 89:1610–1617
- Kruglyak L, Daly MJ, Reeve-Daly MP, Lander ES (1996) Parametric and nonparametric linkage analysis: a unified multipoint approach. *Am J Hum Genet* 58:1347–1363
- Lohman T, Roche A, Martorel R (eds) (1988) Standardization of anthropometric measurements. In: The Airlie (VA) consensus conference. Human Kinetics, Champaign, IL
- McCabe ER (1994) Microcompartmentation of energy metabolism at the outer mitochondrial membrane: role in diabetes mellitus and other diseases. *J Bioenerg Biomembr* 26:317–325
- McCabe ERB (1995) Disorders of glycerol metabolism. In: Scriver CR, Beaudet AL, Sly WS, Valle D (eds) *The metabolic basis of inherited disease*, 7th ed. McGraw-Hill, New York, pp 1631–1652
- McNamara JR, Schaefer EJ (1987) Automated enzymatic standardized lipid analyses for plasma and lipoprotein fractions. *Clin Chim Acta* 166:1–8
- Noel RJ, Antinozzi PA, McGarry JD, Newgard CB (1997) Engineering of glycerol-stimulated insulin secretion in islet beta cells. Differential metabolic fates of glucose and glycerol provide insight into mechanisms of stimulus-secretion coupling. *J Biol Chem* 272:18621–18627
- Pérusse L, Rice T, Després JP, Rao DC, Bouchard C (1997) Cross-trait familial resemblance for body fat and blood lipids: familial correlations in the Quebec Family Study. *Arterioscler Thromb Vasc Biol* 17:3270–3277
- Pettigrew DW, Ma DP, Conrad CA, Johnson JR (1988) *Escherichia coli* glycerol kinase. Cloning and sequencing of the *glpK* gene and the primary structure of the enzyme. *J Biol Chem* 263:135–139
- Pettigrew DW, Smith GB, Thomas KP, Dodds DC (1998) Conserved active site aspartates and domain-domain interactions in regulatory properties of the sugar kinase superfamily. *Arch Biochem Biophys* 349:236–245
- Richterich R, Dauwalder H (1971) Determination of plasma glucose by hexokinase-glucose-6-phosphate dehydrogenase method. *Schweiz Med Wochenschr* 101:615–618
- Richterich R, Dauwalder H (1997) Report of the expert committee on the diagnosis and classification of diabetes mellitus. *Diabetes Care* 20:1183–1197
- Rioux JD, Stone VA, Daly MJ, Cargill M, Green T, Nguyen H, Nutman T, et al (1998) Familial eosinophilia maps to the cytokine gene cluster on human chromosomal region 5q31-q33. *Am J Hum Genet* 63:1086–1094
- Rognstad R, Clark DG, Katz J (1974) Pathways of glyceride glycerol synthesis. *Biochem J* 140:249–251
- Romero NB, Recan D, Rigal O, Leturcq F, Llense S, Barbot JC, Deburgrave N, et al (1997) A point mutation in the glycerol kinase gene associated with a deletion in the dystrophin gene in a familial X-linked muscular dystrophy: non-contiguous gene syndrome involving Becker muscular dystrophy and glycerol kinase loci. *Neuromuscul Disord* 7:499–504
- Rose CI, Haines DS (1978) Familial hyperglycerolemia. *J Clin Invest* 61:163–170

- Sargent CA, Young C, Marsh S, Ferguson-Smith MA, Affara NA (1994) The glycerol kinase gene family: structure of the Xp gene, and related intronless retroposons. *Hum Mol Genet* 3:1317–1324
- Sjarif DR, Sinke RJ, Duran M, Beemer FA, Kleijer WJ, Ploos van Amstel JK, Poll-The BT (1998) Clinical heterogeneity and novel mutations in the glycerol kinase gene in three families with isolated glycerol kinase deficiency. *J Med Genet* 35:650–656
- Sommer S, Nau R, Weiland E, Prange HW (1993) Pharmacokinetics of glycerol administered orally in healthy volunteers. *Arzneimittelforschung* 43:744–747
- Staden R (1996) The Staden sequence analysis package. *Mol Biotechnol* 5:233–241
- Walker AP, Muscatelli F, Monaco AP (1993) Isolation of the human Xp21 glycerol kinase gene by positional cloning. *Hum Mol Genet* 2:107–114
- Walker AP, Muscatelli F, Stafford AN, Chelly J, Dahl N, Blomquist HK, Delanghe J, et al (1996) Mutations and phenotype in isolated glycerol kinase deficiency. *Am J Hum Genet* 58:1205–1211
- WHO Study Group on Diabetes Mellitus (1985) Diabetes mellitus report of a WHO study group. WHO technical report series 727. World Health Organization, Geneva
- Yang XJ, Kow LM, Funabashi T, Mobbs CV (1999) Hypothalamic glucose sensor. Similarities to and differences from pancreatic beta-cell mechanisms. *Diabetes* 48:1763–1772
- Yilmaz MT, Sener A, Malaisse WJ (1987) Glycerol phosphorylation and oxidation in pancreatic islets. *Mol Cell Endocrinol* 52:251–256