

THE STAIRCASE PHENOMENON IN VENTRICULAR MUSCLE.

BY ALISON S. DALE (*Yarrow Student, Girton College*).

(*From the Physiological Laboratory, Cambridge.*)

IN a previous paper [Dale, 1930] a relation between the rhythm and the amplitude of contraction of mammalian (rabbit) ventricular muscle was described. It was found that when the natural rhythm of the perfused rabbit's heart is slowed, the amplitude of the contractions decreases. The same relation was found in the case of perfused ventricular strips. Such strips do not contract spontaneously, and it was shown that, when an artificial rhythm applied to them was halved, the amplitude of the contractions decreased, and returned to its former value when the rhythm was restored to its original rate. It is evident, therefore, that the phenomenon is a property of the ventricular muscle itself, and in the paper referred to above it was ascribed to a form of the staircase phenomenon, first described by Bowditch [1871].

It seemed desirable to make a further study of the phenomenon, and to determine, if possible, the conditions necessary for its appearance.

CONDITIONS OF PERFUSION.

Experience showed that the phenomenon was always present in a strip perfused with a buffered Ringer's solution, provided that the muscle was in good condition. In a feebly beating strip it was not always evident and might even be reversed. Feeble contractions were usually caused by a slow rate of perfusion, and consequent insufficient supply of oxygen. Slowing of the rhythm must in any case increase the amount of oxygen available for each contraction. In cases, therefore, in which the supply is inadequate at a fast rhythm, slowing of the rhythm would be expected to have a beneficial effect on the contractions, masking the decrease observed in normal preparations.

As the phenomenon had only been observed in preparations perfused with a modified Ringer's solution, it seemed possible that it might be

peculiar to the perfused muscle. Some experiments were therefore carried out in which the perfusion fluid was a mixture of blood and Ringer's solution. The Ringer's solution used was buffered with bicarbonate, and was made isotonic for the blood corpuscles by reducing the sodium chloride content. The blood (about 40 c.c.) was obtained from a rabbit by decapitation, whipped, filtered through muslin, and made up to 1000 c.c. with the bicarbonate Ringer's solution. The mixture was then filtered through cotton-wool to remove any shreds of clot which might have passed the muslin. The heart of the same rabbit was used for making the ventricular strip preparation. The perfusion and stimulation apparatus were the same as those described in the previous paper. Perfusion was started with Ringer's solution alone, which was replaced by the mixture of blood and Ringer's solution as soon as this was prepared. Immediately the blood reached the strip, there was an increase in the amplitude of the contractions. This beneficial effect of the blood did not persist however. It was found that after the first increase of amplitude, the contractions became progressively weaker, until they scarcely moved the lever. The cause of the weakening was a gradual decrease in the rate of perfusion, terminating in a nearly complete stoppage of the flow. The reason for this stoppage is not clear, but it seems to be peculiar to the strip preparation, as it is not observed in whole hearts perfused with mixtures of blood and Ringer, or whole blood, though Cushny and Gunn [1913] observed it in whole hearts perfused with mixtures of serum and Ringer. It is possible that, in the strips, the blood corpuscles may accumulate at the cut ends of the coronary capillaries, and block the outflow.

In any case, the onset of this weakening was slow enough to permit observations being made while the excursions were still of reasonable size. Halving of the rhythm then produced the usual decrease in amplitude of the contractions, and subsequent restoration of the original rhythm the return to normal.

EFFECT OF CHANGING pH OF PERFUSATE.

A series of experiments was next carried out with a view to determining whether the relation between rhythm and amplitude could be changed by variations in the composition of the perfusion fluid. Adrian's experiments [1920] on the perfused ventricle of the frog showed that, while at acid reactions a contraction is followed by a short period during which a second contraction is supernormal, this supernormal phase disappears when the perfusion fluid is made alkaline. Adrian concluded

that the presence of the supernormal phase is necessary for the production of the Bowditch staircase. Although, as was pointed out in the previous paper, there is no supernormal phase following a contraction of the rabbit's ventricle, it seemed possible that the supposed staircase effect might be influenced by changes in the reaction of the perfusion fluid.

The strip preparation was again employed. The Ringer's solution was buffered with borate and acetate (H_3BO_3 0.062 p.c., CH_3COONa 0.082 p.c., $NaCl$ 0.8 p.c., KCl 0.04 p.c., $CaCl_2$ 0.021 p.c.) and was brought to the required pH by addition of the appropriate quantity of HCl or NaOH, comparison being made with a standard buffer solution, using phenol red as indicator. Perfusion was always started with a solution at pH 7.5, and this was followed by fluids of more acid and more alkaline reactions. When changing to a solution of a different reaction, half an hour of perfusion with the new fluid was allowed before any records were taken. A record consisted of a series of contractions at the full rhythm, followed by a series at the halved rhythm, and finally a return to the full rhythm. The full rhythm was usually 60 beats per min. This is slow when compared with the natural rhythm of the rabbit's heart, but at the relatively slow rate of perfusion in the strips it is the maximum possible without production of fatigue. Two or three records were taken at each reaction. The excursions of the lever at the full and halved rhythms were then measured, and the decrease in amplitude expressed as the ratio of the excursion at the halved rhythm to that at the full rhythm. It sometimes happened that, when the rhythm was halved, the decrease in amplitude produced was not maintained, but gave place to a gradual increase. This was, no doubt, the result of inefficient perfusion (see above), the beneficial effect of slower rhythm, under these conditions, appearing after a short delay. In such cases the value for the amplitude at the halved rhythm was taken as the minimum reached before the secondary increase set in.

Table I shows a few results typical of those obtained.

It is evident from Table I that there is no significant change in the ratio H/F when a neutral perfusion fluid is replaced by an alkaline one. The small changes which occur are not always in the same direction, and in any case are no greater than the variations among the several values obtained for the same reaction. Figures from records obtained at an acid reaction are not given, as they, also, show no significant variation from normal.

These results are not in direct disagreement with those obtained by Adrian for two reasons. Firstly, the range of reactions employed

TABLE I. Results from two experiments. F is the height in mm. of the record of the contractions at the full rate, H that at the halved rate.
Values for consecutive observations in each experiment.

No. of exp.	Temp. °C.	pH	F	H	H/F
1	33	7.4	10.5	9.2	0.86
		7.4	11.6	10.2	0.88
		7.4	12.5	10.9	0.87
		8.1	9.9	9.0	0.90
		8.1	9.9	8.9	0.89
		7.6	8.2	7.2	0.88
		7.6	9.0	7.6	0.84
2	33	7.6	15.0	13.0	0.87
		7.6	13.0	11.7	0.84
		8.2	11.7	10.0	0.85
		8.2	11.8	10.2	0.86
		8.2	12.0	10.3	0.86
		8.2	12.2	10.2	0.84
		7.6	12.7	10.9	0.86
		7.6	12.7	11.1	0.87

by him was much greater. The rabbit's heart is much more sensitive to changes in composition of the perfusion fluid than that of the frog, and larger changes in reaction would have rendered the muscle so hypotonic, and the excursions of the lever so small, that accurate measurement of the curves would have been impossible. Secondly, as pointed out above, Adrian's experiments were concerned with the supernormal phase, which is not present in rabbit's heart muscle.

CHANGES IN Ca^+ AND K^+ ION CONTENT.

It seemed possible that, as the Ca^+ and K^+ ions have such a profound influence on the contraction of cardiac muscle, alteration of the concentration of these ions in the perfusion fluid might produce some change in the relation between rhythm and amplitude of contraction. Experiments were therefore carried out in which the concentrations of the ions were varied. Solutions were made up, containing normal, halved or doubled concentrations of Ca^+ or K^+ ion, and records were taken in the same way as those described above. The records were measured, and the ratio H/F calculated, but it was found that no change in the ratio was produced by the variations in concentration of the ions.

THE STAIRCASE PHENOMENON IN THE FROG'S HEART.

Most of the previous work on the staircase phenomenon in cardiac muscle has been carried out on the heart of the frog. Many of the observations have been made on the heart *in situ*, others on the perfused

organ. It seems that the staircase phenomenon is not always apparent, and it has become customary to refer to "Treppenbedingungen," *i.e.* the conditions necessary for the appearance of the staircase effect. In the experiments on the rabbit's ventricle just described, these staircase conditions seem to be the normal conditions of experiment, and abnormal ones as well, since it was found impossible to abolish the staircase by any change in the perfusion fluid which was tried. Conditions of fatigue, produced by slow perfusion, were the only ones in which the staircase disappeared.

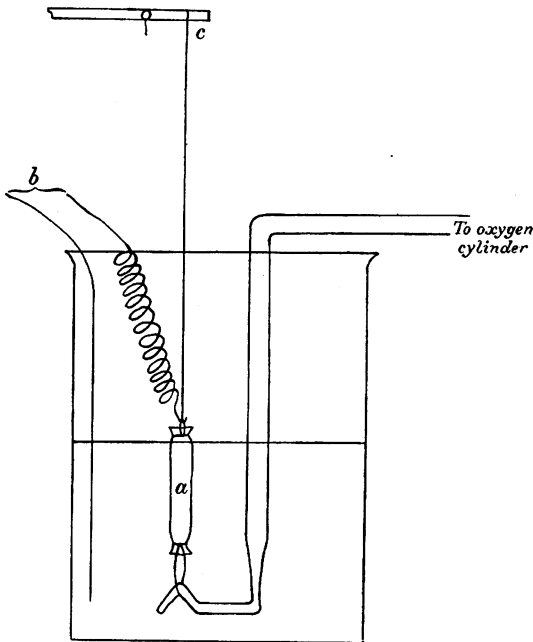

Fig. 1. Isolated strip preparation of frog's ventricle. *a* is the strip; *b*, stimulating electrodes; *c*, lever.

It seemed desirable, therefore, to make some observations on the cardiac muscle of the frog, to determine, if possible, what the nature of these staircase conditions might be. It was necessary that the preparation used should have no rhythm of its own, in order that the rate of beating might be artificially regulated. A strip preparation was therefore employed, and was obtained as follows. The frog was pithed, and the heart removed and placed in Ringer's solution, where it was allowed to beat for a few minutes to wash the blood from it. The auricles were then

cut away at the A.V. groove, and a cut was made across the ventricle, parallel to the groove, and about 2 mm. below it. A ring of ventricular muscle was thus obtained, and this, when cut open, formed the strip. A piece of silk was tied to each end of the strip, one end being secured to a fixed point, and the other end to the lever. The strip was immersed in a beaker of buffered Ringer's solution, through which oxygen was

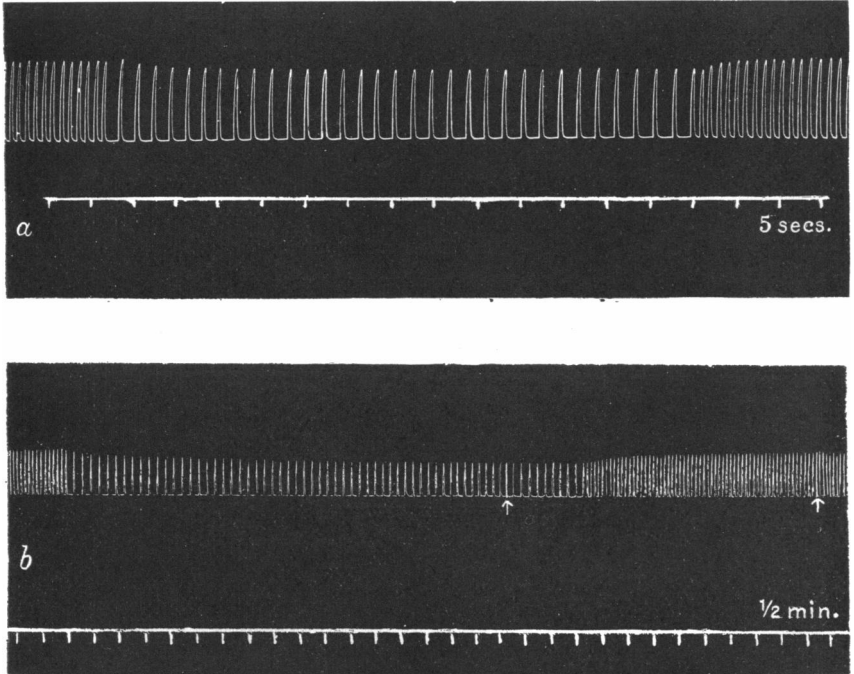

Fig. 2. *a*, record from rabbit's ventricular strip. Effect of halve-rhythm and then restoring it to normal. *b*, record from frog's ventricular strip. Rhythm halved and then restored to normal. ↑ indicate stopping of drum for 2 min.

bubbled. This served both to oxygenate and stir the solution. The solution was made up according to the formula given by Anrep and Segall [1926], this having the advantage that, by mixture of appropriate proportions of two solutions, a fluid of any desired reaction can be obtained. In the first series of experiments the reaction was adjusted to pH 7.5. Fig. 1 shows the arrangement of the apparatus.

The strip was stimulated rhythmically by means of the apparatus employed in the experiments on the rabbit's ventricle, but the motor

was geared down so that the full rhythm was 12 beats per min. This rhythm is very near the optimum for the frog's ventricle at room temperature, fatigue setting in at rates above 16 per min. The presence of the staircase was tested by observing the effect of halving the rhythm. Fig. 2*b* is a typical record, Fig. 2*a* being a record from a rabbit's ventricular strip inserted for comparison.

It is evident that the halving of the rhythm produces a decrease in the amplitude of contraction in the frog's ventricular muscle, as it does in the rabbit's, but the process differs in two respects. In the first place, the duration of the actual "staircase," whether descending or ascending, is much longer in the frog's heart than it is in the rabbit's, in respect of both time and number of beats. This is easily accounted for on the ground that all processes in the frog are slower than those in the mammal. The second difference is more important. It was a striking fact, obvious in the whole heart, and in the ventricular strip of the rabbit, that when the rhythm became slower, the first beat at the lower rate was enlarged, and was then followed by the descending staircase of beats. Again, when the rate changed from a low to a high one, the first beat at the high rate was always smaller than its predecessor, and was followed by an ascending staircase of beats. In the frog's heart these anomalous beats do not occur. On halving the rhythm, the decrease of amplitude begins immediately, and on doubling it, the increase begins with the first beat at the new rhythm. The frog's cardiac muscle therefore differs from that of the rabbit in that, as shown by Adrian, a true supernormal phase follows each contraction.

ATTEMPTS TO ABOLISH THE STAIRCASE.

Various authors have described abolition or reversal of the staircase phenomenon. Adrian, as mentioned above, found that the supernormal phase disappeared when the heart was perfused with an alkaline solution, while Bowditch [1871] and Bornstein [1906] both claim to have produced a reversal of the staircase with atropine. In view of the fact that it had been found impossible to abolish the staircase in strips of rabbit's ventricle, except by defect of oxygen, it was decided to repeat experiments with alkali and atropine on the frog ventricular strips. In neither case did the staircase disappear. When the rhythm was halved the amplitude of the beats still decreased, and increased again on return to the full rhythm, and there was also always an obvious staircase when contractions were resumed after a pause of 30 sec. or more.

In the case of atropine, a possible explanation of the discrepancy

between my results and those of Bowditch and Bornstein, lies in the fact that the concentration of atropine used by them was relatively enormous. Bowditch, using an isolated frog's ventricle filled with fluid, placed 0.6 mg. of atropine sulphate in the ventricular cavity, which, assuming the capacity of the ventricle to be 0.1 c.c., would produce a contraction of 0.6 p.c. Bornstein applied the drug to the heart *in situ* by dropping a 1 p.c. solution of atropine sulphate on its surface. In the present experiments, the addition of a few drops of a 1 p.c. solution to the fluid bathing the muscle, was found to be sufficient to produce a very definite increase in the amplitude of the contractions. The volume of the fluid in the bath was 50 c.c., so that the addition of two drops (0.1 c.c.) of a 1 p.c. solution produced a resultant concentration of atropine of 0.002 p.c. If larger quantities (0.5–1.0 c.c.) of the 1 p.c. solution of the drug were added, the muscle was rendered inexcitable, and the experiment could not be continued. Fiddes [1929] has found that atropine does not always abolish the staircase in the perfused frog's heart.

The discrepancy between the present results and those obtained by Adrian with alkaline perfusion fluid is more difficult to explain. Adrian's observations were made on the first two beats of the staircase only, and it seemed possible that, in the present series, the supernormal phase might disappear at the alkaline reaction, but the subsequent beats might show an increase, on account of a cumulative action of the contractions, such as that suggested to explain the staircase in the rabbit's ventricle. Inspection of the records, however, showed that this was not the case, the supernormal phase being quite evident even at *pH* 10.

There was the further possibility that the difference might lie in the preparation, as Adrian had used whole frog's hearts to which a Stannius ligature had been applied, after perfusion with Ringer's solution of the desired reaction. A few experiments were therefore performed, in which the whole ventricle was perfused, and its contractions recorded "isochorically" in the manner described by Anrep and Segall [1926]. The ventricle was stimulated rhythmically at a rate of 12 per min. and the staircase was studied after pauses in the stimulation of 90 sec. It was found, in confirmation of Adrian's results, that perfusion with an alkaline fluid (*pH* 9) abolished the staircase, the beats now being of equal size, or showing, at the most, a very slight gradual increase. In a further series of experiments a cannula was tied into the ventricle by a thread passing round the A.V. groove, thus rendering the ventricle quiescent, but passing underneath the aorta, so that this was left free for escape

of the perfusion fluid. The contractions were recorded by a lever attached by a thread to the ventricular apex. Three successful experiments of this type were performed, but in only one of them did perfusion with alkaline fluid produce any change. In the other two, supernormal phase and staircase remained, thus eliminating the possibility that the persistence of staircase in strips at alkaline reactions is due to cutting the ventricular muscle. Fiddes [1929] also found that perfusion with alkaline Ringer's solution does not always abolish the staircase. He further showed that, when it does, the staircase can be made to reappear by poisoning with various drugs. It seems therefore, that the H^+ ion concentration cannot be the sole determining factor in production of the supernormal phase and staircase phenomenon. Gasser and Erlanger [1930] have shown that immersion in alkaline Ringer's solution does not always abolish that phase of the action current in nerve, which is associated with the supernormal phase of excitability.

Fiddes [1929] found that staircase is abolished by halving the NaCl content of the perfusion fluid. This was tried on the strip preparation in one experiment, and it was found that though no staircase was evident when the stimulation had been interrupted for 1 min., after pauses of 4, 5 and 10 min. there was an obvious staircase. The reduction of the first beat was, however, much less than it would have been, had the perfusion fluid contained the normal concentration of NaCl. Halving the NaCl content does not abolish the staircase therefore, but decreases its intensity.

THE CAUSE OF THE STAIRCASE.

Several writers have brought forward theories to explain the appearance of the staircase phenomenon. Lee [1907] showed that asphyxia, or perfusion with fluids of acid reaction, caused an increase in the contractions of rhythmically stimulated skeletal muscles, and that the increase took the form of an ascending staircase of contractions. He concluded that the staircase was produced by an accumulation of metabolites (CO_2 , lactic acid) which favoured an increase in the amplitude of contraction. Mines [1913] put forward a similar theory to explain the occurrence of an optimal rhythm and staircase in cardiac muscle. He concluded that the pH of resting muscle is on the alkaline side of the optimal, but that at a definite interval after a contraction, the optimal interval, the diffusion through the tissue of the acid produced by the contraction will bring the reaction of the tissue to the optimal value, and a contraction elicited at this moment will be larger than the first.

This theory was dismissed by Adrian when he found that the supernormal phase is still present at acid reactions, but is abolished by alkali.

In the paper to which reference has already been made [Dale, 1930], it was suggested that the staircase phenomenon in the rabbit's ventricle was due to a cumulative action of the contractions. In this muscle it is impossible to assume the presence of an optimal interval, for when the rhythm at which a strip of ventricle is being driven is accelerated, the beat following the first short interval is diminished in amplitude, to be followed by an ascending staircase of beats. In the frog's heart, on the other hand, there is an optimal interval, the first beat after a change from a halved to a full rhythm being larger than its predecessor. If, however, the optimal interval were the only factor involved, we should expect the beats following this enlarged one to equal it in amplitude. Actually there is a staircase, suggesting that here also there is a cumulative action of the contractions. Again, when the rhythm of the strip of frog's ventricle is halved, the beat after the first long pause is smaller than its predecessor, but instead of the subsequent beats remaining at this amplitude, they show a gradual decrease in a descending staircase. This suggests that the supposed cumulative action of the beats at the full rhythm leaves some after-effect, which passes off gradually, and only when this has disappeared does the amplitude of the contractions at the halved rhythm become constant. Further, if the amplitude of the contractions at any given rhythm is determined by their cumulative action, this action must be more intense at fast rhythms than at slow, and we might expect the after-effect to vary accordingly. A series of experiments was carried out to test this point. Pauses of varying length were interposed in two series of contractions, one at 12 per min. and the other at 6 per min. and the amplitude of the first beat after each pause was taken as a measure of the intensity of the after-effect at that interval.

In order to obviate errors due to friction between the writing point and the drum, the movements of the lever were recorded by throwing its shadow on to a moving sensitive paper. The strip of frog's ventricle was prepared and set up as already described, the arrangement of the lever being slightly different, as the sensitive paper in the camera moved vertically. A small L-shaped piece of brass was pivoted at the angle, the light straw pointer was attached to the vertical arm, and the thread from the muscle to the horizontal arm. The downward movement of the latter was resisted by an elastic band. After setting up the preparation, 2 hours, during which it was rhythmically stimulated, were allowed for it to come into equilibrium with the surrounding Ringer's fluid. It was

found by experience that the amplitude of the contractions gradually increases over such a period, then reaching a constant value. A series of records was then taken, interposing pauses of various lengths in the series of stimulations. As will be seen from Fig. 3, the pauses varied from 2 to 10 min. A few beats were recorded during rhythmical stimulation,

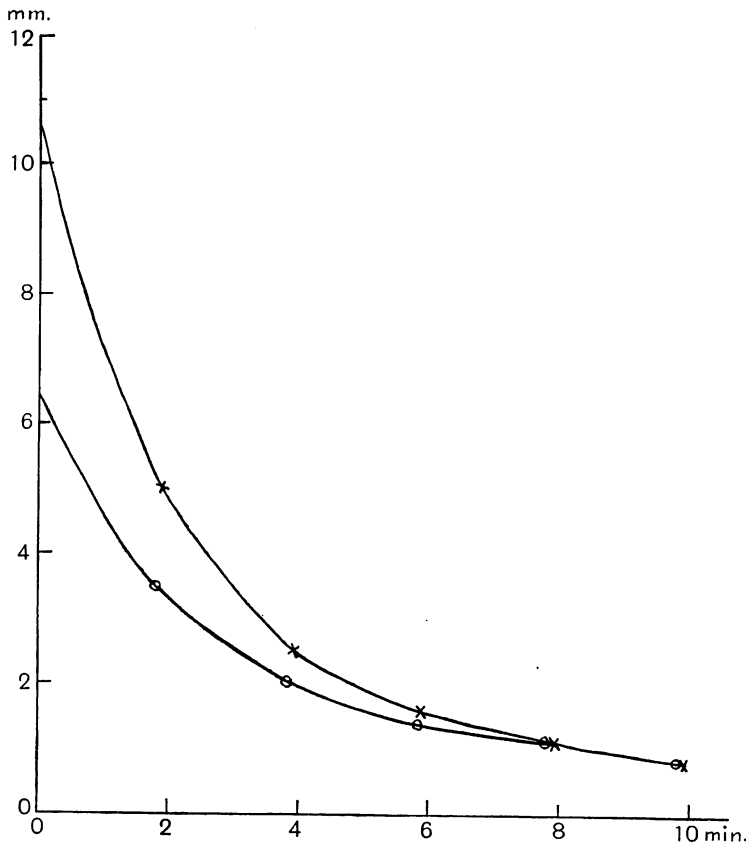

Fig. 3. For description see text.

stimulation was stopped for the desired interval, and then a record made of the first few beats on resumption of stimulation. It is very important, if consistent results are to be obtained, that sufficient time be allowed for recovery after a pause, before the next observation is made. After a pause of 10 min., as much as half an hour may be necessary before the amplitude of the contractions again reaches a constant value, and enables another test of the effect of an interruption to be made.

Fig. 3 shows the results of a typical experiment plotted graphically. The length of the pause is plotted as abscissa, and the corresponding first excursion of the lever in mm. as ordinate. The durations of the pauses plotted represent the excess over the normal interval in the rhythm of stimulation, thus enabling the excursion of the lever characteristic of rhythmic stimulation to be plotted against zero time. It is evident from the figure that the after-effect left by a series of contractions at a rate of 12 per min. is greater than that left by a series at half that rate. Further, the after-effect due to the beats at the faster rhythm disappears more rapidly at first than that produced by those at the slower rhythm, so that after an interval of 8 min. the curves meet and descend together.

In the previous paper, a tentative theory was put forward to explain the fact that, when the rhythm at which a strip of rabbit's ventricle is beating becomes slower, the beat following the first long pause is enlarged. It was suggested that this enlargement might be caused by such an after-effect as has just been described for the frog's ventricle. If this explanation holds, the size of this first beat should decrease as the length of the pause increases, and a series of experiments was therefore carried out on perfused strips of rabbit's ventricle to test this.

The perfusion apparatus was the same as that already described for rabbit's ventricular strips. It is very important for quantitative experiments, however, that conditions such as temperature should be kept constant. The strip preparation, the warming coil, and the tube connecting the two, were therefore enclosed in a box, which was heated by means of a carbon filament lamp, which maintained the temperature inside the box in the neighbourhood of 34° C. The Mariotte's bottle and oxygenating tower were outside, and the tube connecting the latter with the warming coil passed through a hole in the top of the box. The contractions were recorded by means of a Wiggers' miniature myocardiograph [Wiggers, 1916]. This was slightly modified for the present purpose, the needles which form the attachments to the heart muscle being placed further apart, in order to include a greater length of muscle between them, and so give a bigger excursion. This was accomplished by soldering a small piece of brass on to the bottom of the capsule, and mounting the fixed needle on this. The capsule was joined by thick-walled rubber tubing to a piece of lead pipe, which passed through the side of the box, and made connection with the recording capsule outside. A T-tap was placed in this connection, so that the myocardiograph could be connected, either with the recording capsule, or to the side tube of the T-tap which was open to the air. Between the taking of records the tap

was turned so that the myocardiograph was connected to the side-tube, allowing the muscle to shorten, and thus keeping it in better condition. It is important, in recording from this preparation which hangs freely from the cannula, that the myocardiograph should be held fairly rigidly. If it is free to move, the contraction of the strip twists it into such a position that the approximation of the needles is minimal, and a very small excursion is obtained on the record. An optical method of recording was used, the recording capsule carrying a small mirror which reflected the image of a bright line on to the lens of a moving paper camera. The bright line was the filament of a "Baby Ciné" lamp. The stimulating electrodes were two fine silver wires which hooked into the muscle. The

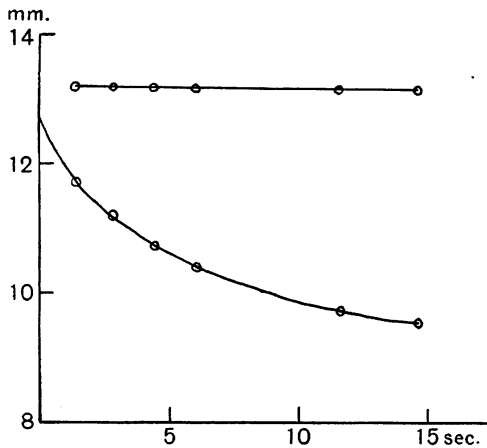

Fig. 4. For description see text.

rotary contact breaker, already described, was used, and a switch was included in the primary circuit, so that a pause could be interposed in a period of rhythmic stimulation by cutting out any desired number of beats. It was found that when the myocardiograph is attached to the strip, the optimal rhythm is much slower than when the strip is pulling on a lever, as in previous experiments. At a rhythm of 40 per min., the muscle remained in good condition, but at rhythms much faster than this fatigue set in. The pauses were relatively much shorter in duration than those employed in the experiments with the frog's ventricle. The minimum pause was that produced by cutting out one beat, while the maximum was determined by the fact that after pauses of a certain length, varying in different preparations, the first beat is abnormal, in that it is followed by a spontaneous premature contraction. In some preparations this may

appear after pauses of five beats' duration, in others not until the pause has reached a duration of fifteen beats. In the preparation from which Fig. 4 was obtained, it was possible to cut out ten beats without the appearance of a premature contraction on return to stimulation.

The excursions of the spot of light on the paper were measured and plotted against the duration of the pauses in the same way as was described for the experiments with the strips of frog's ventricle. Fig. 4 shows the results of a typical experiment. The upper straight line gives the values for the enlarged first beat, and it will be seen that the duration of the pause has no effect on the amplitude of this contraction. The amplitude is the same, whether the pause be of one or ten beats' duration. The explanation of the enlargement of the first beat put forward in the previous paper is therefore untenable. If, however, the excursion of the spot of light for the beat following the first enlarged one is measured, it is found that this decreases as the pause increases in duration, and the lower curve of Fig. 4 is obtained.

DISCUSSION.

The experiments just described strongly support the theory that the staircase in cardiac muscle is due to a cumulative action of the contractions. The results obtained give little evidence, however, as to the nature of this action. There are two possibilities: (1) as suggested by previous writers, it may be of a chemical nature, an accumulation of some metabolic product which favours muscular contraction; (2) a change in the visco-elastic properties of the muscle brought about by the contractions.

The first possibility is supported by the experiments of Joffé [1931] on the ventricle of the frog. He finds that fluid which has perfused a rhythmically stimulated, isolated ventricle, augments the contractions of a second ventricle when added to the fluid perfusing it. The activity of the fluid is greater, the larger the number of contractions performed by the first ventricle, while the fluid is in its cavity. If such a substance is the responsible factor, the production of the staircase may be explained as follows. During the ascent of the staircase the active substance diffuses away less rapidly than it is formed, so that its concentration in the muscle increases and favours an increase in the amplitude of the contractions. As the concentration increases the rate of diffusion will increase, and a point will be reached when the rate of diffusion equals the rate of formation. The concentration of the substance, and likewise the

amplitude of the contractions, will then have reached a maximum, and will remain constant. Further, if we assume that every contraction liberates an equal amount of this substance, the faster the rhythm, the greater will be the rate at which the substance accumulates. At fast rhythms therefore a high concentration must be attained before the rates of formation and diffusion are equal, and the resultant amplitude of contraction will be large. Again, in considering the curves of Fig. 3, it was pointed out that the curve obtained when the initial rate was 12 per min., fell more steeply at first, than that resulting from an initial rate of 6 per min. This is readily explained, if the initial concentration of the substance is greater at the fast rhythm. Its rate of diffusion will then be greater, and it will disappear more rapidly. In the case of the descending staircase produced by slowing the rhythm, the rate of formation of the substance by the contractions at the slower rhythm will at first be less than its rate of diffusion, the initial concentration being that characteristic of the faster rhythm. The concentration will decrease, however, and with it the rate of diffusion, so that a point will be reached when the rates of formation and diffusion are once more equal. The concentration at this new equilibrium point will be less, and the amplitude of the contractions therefore smaller.

The second possibility, mentioned above, has been suggested by Fischer [1930] to explain the phenomena of the staircase in the sartorius of the frog. He finds that the length of the period of rest preceding the staircase is a more potent factor in reducing the size of the first beat than is the amount of washing that the muscle has received during that period. He concludes that, in this case, the accumulation of metabolites is not the cause of the staircase. As it is not certain that the phenomenon is the same in skeletal as in cardiac muscle, it does not follow that this theory can be applied to the latter.

The first theory fits the experimental facts exactly, as far as the ventricular muscle of the frog is concerned. In the case of the rabbit's heart, it is more difficult to apply. With regard to the question of the supernormal phase, we may assume that, while in the frog's heart enough of the substance is produced by one beat to augment the contraction of a second, in that of the rabbit two beats are necessary before the required concentration is attained. The fact for which the theory has no explanation is the enlarged first beat following a pause. As is shown by the results given in Fig. 4, the amplitude of this beat bears no relation to the length of the pause preceding it, indicating that the substance left by the preceding series of contractions is not responsible. It seems

that some separate factor must be involved. It was thought that this might be connected with the perfusion, but stopping the flow of perfusion fluid during the pause, made no difference to the size of the first beat following it. Further experiments are necessary to determine the nature of this factor, and it is proposed to carry them out on isolated strips of rabbit's auricle. This should be an easier preparation to handle than the ventricle, as it does not require perfusion. That the enlarged beat occurs in the auricle is obvious from the tracings taken from the whole heart, and published in the previous paper (Figs. 2*a* and 3*a*).

SUMMARY.

1. The staircase phenomenon in the perfused ventricular strip of the rabbit is unaffected by changes in concentration of H⁺, Ca⁺, or K⁺ ions in the perfusion fluid.
2. The staircase phenomenon is present in the ventricular strip of the frog. In this preparation it is unaffected by changes in the H⁺ ion concentration of the surrounding fluid, and is not abolished by atropine.
3. The staircase phenomenon in the ventricles of the frog and rabbit is due to the accumulation of some substance liberated during contraction.

In conclusion, I wish to express my thanks to Prof. Barcroft for permission to carry out this work in the laboratory at Cambridge, and to Prof. Adrian and Dr A. N. Drury for their advice and criticism.

REFERENCES.

- Adrian, E. D. (1920). *J. Physiol.* **54**, 1.
 Anrep, G. V. and Segall, H. N. (1926). *Heart*, **13**, 61.
 Bornstein, A. (1906). *Arch. f. Anat. u. Physiol.* Physiol. Suppl. 343.
 Bowditch, H. P. (1871). *Ludwigs Arbeiten*, **139**.
 Cushny, A. R. and Gunn, J. A. (1913). *J. Pharmacol.* **5**, 1.
 Dale, A. S. (1930). *J. Physiol.* **70**, 455.
 Fiddes, J. (1929). *Quart. J. Exp. Physiol.* **19**, 243.
 Fischer, E. (1930). *Pfluegers Arch.* **225**, 532.
 Gasser, H. S. and Erlanger, J. (1930). *Amer. J. Physiol.* **94**, 247.
 Joffé, E. (1931). *Arch. int. de Physiol.* **34**, 305.
 Lee, F. S. (1907). *Amer. J. Physiol.* **18**, 267.
 Mines, G. R. (1913). *J. Physiol.* **46**, 1.
 Wiggers, C. J. (1916). *Amer. J. Physiol.* **40**, 218.