

THE EFFECT OF IONS ON THE PHOTORESPONSES OF PIGEON CONES

BY G. B. ARDEN AND W. ERNST

*From the Department of Neurophysiology, Institute of Ophthalmology,
Judd Street, London, W.C.1*

(Received 6 April 1970)

SUMMARY

1. Pigeon cone receptor potentials have been identified in a preparation of isolated, incubated retina.

2. There is an approximately linear relationship between response amplitude and sodium concentration of the bathing medium.

3. A decrease of chloride ions produces results equivalent to a decrease of sodium ions. The response amplitude is a power function of the product of the sodium and chloride concentrations. For most experiments, the exponent is *ca.* 1.

4. After treatment of the retina with ouabain, responses vanish, but can be temporarily restored, in normal, or inverted polarity, by appropriate changes in sodium or chloride concentration.

5. Ammonium and potassium ions can substitute quantitatively for sodium ions. Lithium ions initially carry response currents, but later block all responses. Bromide, nitrate and thiocyanate can substitute for chloride ions.

6. The response wave form, and the amplitude/light intensity relationship are independent of ions.

7. Models of the photoreceptor are discussed. It is concluded that the membrane potential of the cone in light is chiefly determined by the distribution of anions across the membrane, and in darkness there is an increase in outer limb cation permeability.

INTRODUCTION

Studies by Brown and his co-workers (Brown, Watanabe & Murakami, 1965) have shown that light causes changes in the current flowing round the distal portions of the receptors. They have called these changes the late receptor potential. In previous work (Arden & Ernst, 1969*b, c*) we have demonstrated that a sodium concentration gradient across the cone

membrane in either direction is a sufficient condition for the production of a cone potential. Thus, following treatment of the pigeon retina with ouabain, the cone potentials gradually disappear, presumably because ouabain interferes with the mechanism maintaining the gradient. When the gradient is restored in the normal direction by increasing the sodium in the medium bathing the cones, the potentials recover in the normal polarity. Likewise, when the gradient is established in the opposite direction, by decreasing the sodium, the potentials reappear, but in an inverted polarity.

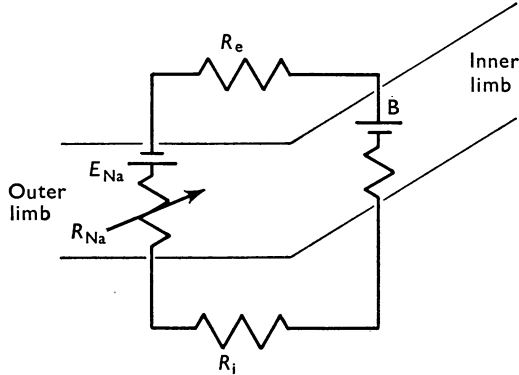

Fig. 1. Electrical equivalent circuit of part of the cone. The variable sodium conductance of the outer limb membrane is shown as a battery in series with a resistor. The battery B in the inner limb contributes to the membrane potential recorded by an intracellular micro-electrode. Extracellular electrodes record variations in the current flowing down R_e as the receptor potential.

Our findings, combined with those of other workers, lead to the electrical equivalent circuit of the cone shown in Fig. 1. The polarity of the sodium concentration cell must be as shown, since a reduction in the concentration of extracellular sodium decreases the amplitude of the receptor potential, and our ouabain experiments show that the cone currents flow in the direction of the sodium concentration gradient. Intracellular records from cones (Toyoda, Nosaki & Tomita, 1969; Baylor & Fuortes, 1970) indicate that some portion of the cone membrane actively hyperpolarizes on illumination, while Brown *et al.* (1965) have shown that the late receptor potential originates at the same site as the early receptor potential, viz. the outer limb.

In the circuit of Fig. 1, the battery in the inner limb is unspecified. The series resistance, R_{Na} , increases on illumination to produce the required changes in membrane voltage and extracellular current flow. Hence the membrane permeability to sodium ions must be higher in darkness than in light. This will lead to the production of a 'dark current' down R_e , which

is reduced by light. This model predicts the type of current flow actually observed in rat rod preparations (Penn & Hagins, 1969), though the outer limb battery in these rods is not the same as in cones (Arden & Ernst, 1969*b, c*).

This paper extends our earlier investigations with the aim of determining whether the simple model of Fig. 1 can adequately describe the effects of various ions on the extracellularly recorded cone potential.

METHODS

Preparation of retinae

Pigeons were dark adapted for at least 2 hr and decapitated in a darkroom illuminated by red safelights. The eyes were removed and hemisected. The eyecup was illuminated momentarily with white light from a hand torch and the position of the pinkish dorsal quadrant identified. This portion was cut away from the remainder of the eyecup and placed in a Petri dish containing a standard solution (see Table 1). The retina was then teased away from the underlying pigment epithelium. It was often difficult to obtain complete separation of the pigment epithelium. The retina was placed on the grid of the incubation chamber and again inspected with white light. Since the dorsal quadrant was larger than the grid, it was usually possible to place the retina so that no visible pigment or colourless portion of the retina lay over the grid. The chamber section was then removed from the Petri dish, the chamber assembled, placed in the optical system, and the perfusion begun. The entire procedure took about 10–14 min.

Chamber

The perfusion chamber (Fig. 2) consisted of two thin circular Perspex plates with the retina sandwiched in between. 5 mm holes were bored in the plates, and the gaps were covered by Orlon net on the rear surfaces which acted as a grid supporting the retina. The net was flexible and did not compress the retina. The Perspex plates had a thickness of about 0.2 mm at their centres: the rims were much thicker and were fitted with locating pins, so they could be apposed without rotation. They could be firmly screwed together by a peripheral screw-ring. One of the plates was made of black opaque Perspex and this was placed nearest the light source, so that only the retina between the grid was illuminated. The back surface of the black plate had a slight central depression to accommodate the edges of the retina outside the grid. There was no fluid leak between the two plates when they were screwed together. The rims of the plates were machined to take two Perspex caps. These contained electrode wires, and two 'O' serum needles. The caps were a tight fit on the plates and, when lightly greased, fitted without a fluid leak. The chamber was mounted vertically on an optical bench. Fluid entered on both sides of the retina at the lowest point in the chamber, and left at the highest point. The total volume of the chamber was about 1.5 ml. The flow rate was 20 ml./min. Total replacement of fluid could be achieved in 15 sec, and this is the period in which the composition of the medium bathing the outer limbs was uncertain. When the interelectrode resistance was continuously measured (with a retina in place) changing the solution resulted in slower drifts of impedance (0.5–1 min) which are probably due to the slow replacement of extracellular fluid at deeper points in the retina.

Electrical recording

The recording electrodes were chlorided silver wires. The voltage across the chamber was measured with a parametric pre-amplifier (Medelec Ltd.), connected to a

Tektronix 502A oscilloscope. A band width of 0–100 Hz was used. Total noise was approximately $3 \mu\text{V}$, and long term drift was typically $10 \mu\text{V}/\text{min}$. However, when changes were made to solutions lacking chloride ions, large transient DC voltage drifts were observed. In many experiments, therefore, a band width of 10–100 Hz was introduced. This distorted the responses and made them appear biphasic; this was acceptable since only relative response amplitudes were to be measured and pronounced changes did not occur in the rate of rise and decay of the responses. In such

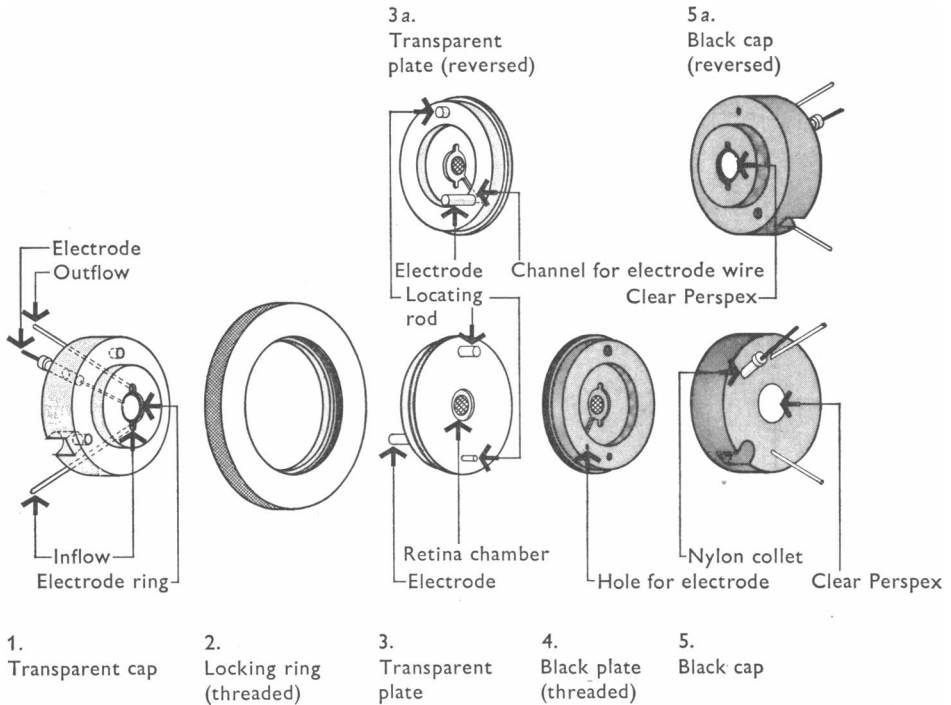

Fig. 2. Exploded view of incubation chamber.

experiments, the oscilloscope output was taken to a penwriter, running at 0.25 mm/sec and each response appeared as a vertical line. The band width of the pens was greater than 40 Hz. These recordings were routinely supplemented by photographic records from the oscilloscope face (band width 0.5–100 Hz). In order to convert the voltages recorded into estimates of current flow, the conductivity of the solutions employed was measured on a bridge, either using a standard cell, or using the chamber (with the retina in place) as a conductivity cell. Both methods gave similar relative conductivities for the solutions employed, indicating that the retinal resistance was either very low, or that it was shunted by leakage pathways. It was observed that the responses recorded were somewhat larger if the pigment epithelium was present: this is known, in other animals, to have a considerably higher resistance than the retina (Brindley, 1956).

Stimulation

A regulated DC driven xenon arc lamp was used as a light source. An even patch of light covering the grid of the chamber was obtained from a conventional optical

system. A pen motor shutter was used to give 15 msec light pulses (rise and fall time 0.5 msec). Colour filters (Schott, Depal interference and Wratten spectrum) and neutral filters (Kodak) were inserted in the beam when required. The relative spectral energies passed by the colour filters were determined with a thermopile. Measurements were also made of the densities of the neutral filters for light of different wave-lengths.

Media

Incubating media were made up from stock solutions of Analar grade reagents (or equivalent) on the day of the experiment. All solutions had a pH of 7.5 (± 0.1) and a calculated osmolarity of approximately 0.34 osmole if complete dissociation of all salts was assumed. Direct measurements by a vapour pressure method showed that a medium with 125 mM sodium chloride as its main ingredient had an osmolarity 11% less than calculated, while a medium with 131 mM Tris-chloride had an osmolarity 16% less than calculated. Sodium and potassium contents of the media were frequently checked by flame photometry.

In earlier work (Arden & Ernst, 1969*a*) we showed that to isolate the receptor potential from a rat retina, it was necessary to remove any calcium present. Although, even in the presence of calcium, *b*-waves were not observed from the isolated pigeon retina, all the media used in the experiments of this study have been variants of those devised for the rat retina and most of them have contained 0.32 mM-EDTA for the purposes of chelating any traces of calcium. Details are given in Table 1. The standard medium was so called, because it was the one commonly used for dissection and to determine whether the preparation was satisfactory. Reconstituted human plasma (3 ml.) was usually added to 100 ml. of medium. In some experiments, however, the effects of media containing fewer ingredients were investigated and from these plasma was omitted.

The media were kept in a water-bath. Most media were bubbled with 95% O₂ and 5% CO₂. The water-bath temperature was 31° C ($\pm 0.1^\circ$ C) and the temperature in the chamber was 30° C. Multiway taps permitted a variety of experimental media to be introduced into the chamber. The flow rate was controlled by a pressure head and a pump was used to return the effluent to the reservoirs which contained *ca.* 100 ml.

Responses

Microscopic examination of the pink dorsal quadrant of the pigeon retina showed that almost all the receptors in this region possess the coloured oil droplets characteristic of pigeon cones. The responses to light produced by the receptors resemble other cone potentials in their duration and also in the level of illumination at which they appear and the level at which they saturate (Brown *et al.* 1965; Baylor & Fuortes, 1970; see also Fig. 19). The relative spectral sensitivity of the pigeon cone responses was determined by conventional methods and is shown in Fig. 3; it is clearly that of a photopic mechanism.

Responses of approximately 0.5 mV were recorded with intense stimuli (log intensity (in ft.-lamberts) = 2). Usually the light was attenuated. If the preparation was satisfactory, brief pulses of light caused voltage changes between the electrodes, which peaked in about 100–150 msec and which declined to zero in 400–500 msec. During the course of an experiment the responses dwindled in amplitude. The deterioration of the condition of the retina was gradual, and in prolonged experiments repeated sets of measurements were made in random sequence, so that alteration of the response properties did not affect the results. In successful experiments about fifty changes of medium could be accomplished. After this, the response amplitude became small and the duration increased. This could be easily seen on the pen recorder and the experiment was then stopped.

TABLE I. Chemicals used for incubating retinæ

Standard	NaCl (mM)	Na ₂ SO ₄ (mM)	KCl or KHCO ₃ (mM) ^(a)	LiCl (mM)	Tris- chlo- ride (mM) ^(b)	Choline bro- mide (mM)	Tris- sul- phate (mM)	Sucrose (mM)	Tris- phos- phate (mM) ^(c)	MgSO ₄ (mM)	Citric acid (mM)	Glucose (mM)	EDTA (Na salt) (mM)	Plasma (ml./ 100 ml) ^(d)
A ^(e)	62	0	2.5	0	68	0	0	0	71	1	1	10	0.32	3
B ^(e)	125	0	2.5	0	0	0	0	0	65	1	1	10	0.32	3
C ^(e)	0	0	2.5	0	131	0	0	0	65	1	1	10	0.32	3
D ^(e)	0	62.5	2.5	0	0	0	0	62.5	65	1	1	10	0.32	3
E	0	0	127.5	0	0	0	0	0	65	1	1	10	0.32	3
F ^(f)	0	0	0	0	0	150	0	0	15	1	1	10	0.32	0
G	100	0	0	0	0	0	0	0	187	0	0	0	0.32	3
H ^(g)	0	0	0	0	71	0	0	0	0	0	0	0	0.32	0
I	0	0	0	0	171	0	0	0	0	0	0	0	0	0
J	0	0	0	0	0	0	160	0	15	1	1	10	0.32	0
	0	0	0	60	105	0	0	0	0	0	0	0	0	0

(a) Most media contained 2.5 mM KHCO₃. Additional K⁺ made up with KCl.

(b) Buffered to pH 7.5 with Tris-base.

(c) Tris-base buffered to pH 7.5 with H₃PO₄.

(d) Plasma contributed an extra 5-7 mM-NaCl to any medium to which it was added.

(e) These media were mixed in varying proportions to alter anion and cation concentration.

(f) Potassium and ammonium media made by substitution of appropriate cation.

(g) In some experiments EDTA added to this medium.

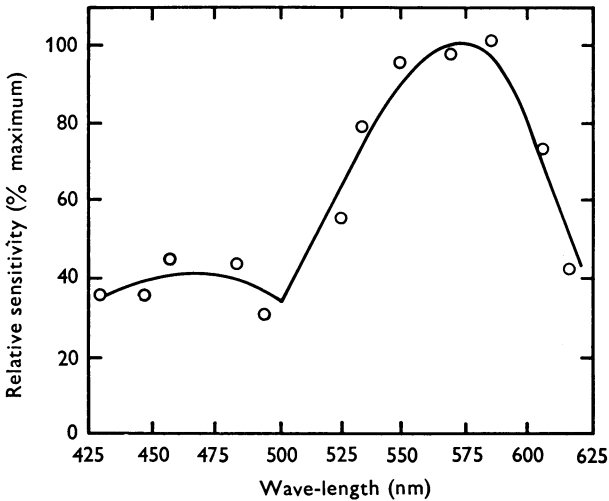

Fig. 3. Relative spectral sensitivity of the pigeon cone potential.

RESULTS

The dependence of response amplitude on sodium concentration

Fig. 4 illustrates the type of qualitative evidence that leads us to conclude that a sodium concentration cell is involved in the production of pigeon cone photoresponses. The record comes from an experiment in which the retina was initially maintained in a standard medium (see Table 1 for details). The first change was made to a Tris-chloride medium (see caption to Fig. 4) and the responses immediately decreased in amplitude. Restoration of the standard medium brought the responses back to their former size. Replacement of the standard medium by a Tris-phosphate one resulted in the immediate appearance of responses of inverted polarity. In the standard medium again the cones produced large responses, though not as large as those seen before the Tris-phosphate exposure. An increase in the sodium concentration of the medium (medium A, Table 1) caused a considerable increase in the size of the responses, but this was not maintained and within several minutes the responses were smaller than they had been with the standard medium. A change now to the Tris-chloride medium, in contrast to its previous effect, led to large responses of inverted polarity. After a time these declined to zero and were succeeded by tiny responses of normal polarity. At the end of the experiment a change was made to the standard medium.

The concentration cell hypothesis requires two additional assumptions to account for these observations, viz. that chloride ions play a role in the production of the responses and that the concentration of intracellular

sodium may change during the course of the experiment. The first explains the difference in effect between the Tris-chloride and -phosphate media. The second explains the difference in effect between the two changes to the Tris-chloride medium. It seems probable that following an increase in the concentration of extracellular sodium, the concentration also rose inside the cones, thereby causing a gradual reduction of the concentration gradient across the cone membranes and hence the observed decline in

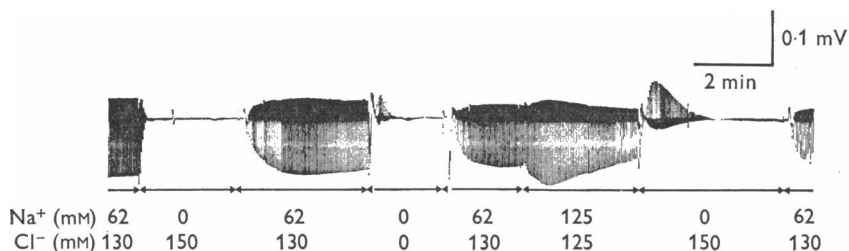

Fig. 4. Dependence of amplitude of cone response on sodium and chloride ion concentration of the bathing medium. Part of a continuous record. Throughout the experiment the retina was stimulated once in 3 sec by a 15 msec flash. The response appears as vertical line. The bandpass of the system (10–100 Hz) partially differentiates the responses, and produces the slower overswing (dark). It is thus easy to see when the response polarity inverts. Disturbances to the base line are caused by switching taps to admit or recirculate different media, and by effects of the media on the electrodes. The Tris-chloride medium contained 75 mM Tris-chloride, 187 mM Tris-phosphate and 0.32 mM-EDTA. The Tris-phosphate contained 332 mM Tris-phosphate and 0.32 mM-EDTA. Traces retouched.

response amplitude. The second change to the Tris-chloride medium thus occurred after the accumulation of a considerable amount of sodium in the cones, so that on this occasion, in contrast to the previous one, there was a large sodium gradient in the direction opposite to normal, and large inverted responses were seen. Presumably these died away as sodium leaked out. The significance of the later reappearance of responses of normal polarity will be discussed below.

The quantitative relation between the amplitude of the response and the sodium concentration of the bathing medium was investigated in two different types of experiments. In one, the retina was maintained in a medium containing 116 mM sodium chloride and the sodium was replaced by calculated equiosmotic amounts of choline or Tris; in the second, the standard medium contained 69 mM sodium which was both decreased and increased over the range 1–126 mM with Tris as the non-permeant substitute for sodium (mixtures of media A and B, Table 1). Estimates were made of the response amplitude before and immediately after the standard had been replaced by a different medium. The amplitude after the change was

expressed as a percentage of the amplitude before, allowing for the change in conductivity of the medium. Fig. 5 shows relative response amplitude plotted as a function of sodium concentration. Both ordinate and abscissa scales are linear. It can be seen that for both experiments a straight line may be fitted to the results with the exception of those obtained at the lowest sodium concentrations. By contrast, if the same results are graphed on a linear-log plot, a straight line can only be fitted over a limited range.

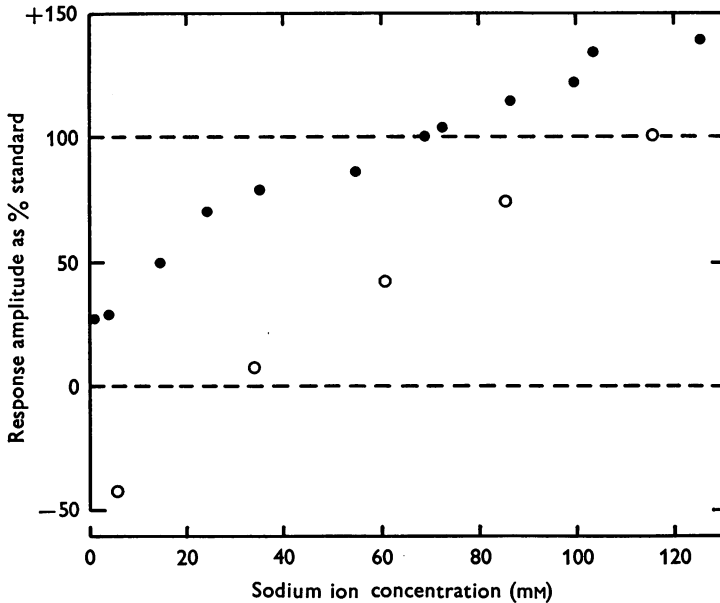

Fig. 5. The dependence of cone response on sodium concentration in the bathing medium. Open circles: retina maintained in medium containing 116 mM sodium. Filled circles: retina maintained in medium containing 69 mM sodium. In this experiment sodium-free plasma (obtained by dialysis) was added to the media. For further description see text.

This indicates that the extracellular currents recorded in these experiments are not simply proportional to a membrane voltage given by the Nernst equation for a sodium concentration cell.

It might be argued that the experiments of Fig. 5 were performed under circumstances where there are other sources of light sensitive voltage producing the extracellular currents. In our earlier work (Arden & Ernst, 1969*b, c*) we showed that by treating the retina with 10^{-4} M ouabain we could abolish the cone responses, yet restore them again by changing the sodium concentration of the bathing medium and nothing else. The fact that the recovery followed immediately on the sodium changes argued that it was these alone which were responsible for the effect. Experiments on

the sodium effect were therefore done on retinae maintained in a medium containing 7 mM sodium (medium B, Table 1) and treated with 10^{-4} M ouabain to abolish the responses. Following ouabain treatment, exposures to high levels of sodium lead to changes in the responses wholly consistent with the idea that the sodium in the bathing medium immediately begins to equilibrate with the intracellular fluid of the cones. For this reason exposures were kept brief and the initial rate of increase in response amplitude after the medium change was used as a measure of the response in a given medium.

Since each exposure produced a decline in the responses, the responses in a control medium containing 50 mM sodium were determined before and after the exposure of the retina to an experimental medium and the experimental responses were expressed as a percentage of the mean of the 'before' and 'after' control responses. In these experiments it was not possible to repeat observations twice for every sodium concentration; so two separate experiments were performed under similar conditions. The results are shown in Fig. 6 on a log-log plot. They can be fitted to a straight line with a slope of 1.3 which means that the relation found for the results of Fig. 5 does not apply to retinae treated with ouabain. However, the experiments of Fig. 6, like those of Fig. 5, provide little support for a linear-log relation between the cone response and sodium concentration.

The role of chloride ions

The experiment of Fig. 4 leads to the assumption that chloride as well as sodium ions are involved in the production of the photoresponse. Further evidence for this view comes from the fact that in media such as H of Table 1, which consists entirely of Tris-chloride (and from which even EDTA is excluded) the retina is capable of producing small responses of normal polarity for periods longer than 20 min. For example, such responses can be seen in Fig. 15. A change to a medium such as I of Table 1 in which Tris-sulphate is used in place of Tris-chloride, always results in the production of transient inverted responses which die away within 3 min, as shown in Fig. 4, or in no response at all. A change from medium I back to a Tris-chloride medium results in the recovery of small responses of normal polarity.

Experiments on retinae treated with ouabain reinforce the view that chloride ions play a role in the production of the receptor potential. The responses at the beginning of the record shown in Fig. 7 were obtained from a retina which had been kept for some time in a medium similar to A containing 128 mM sodium chloride and 10^{-4} M ouabain. Small potentials of normal polarity were still present indicating that the interior of the cones had almost, but not completely, equilibrated with the bathing medium.

When the chloride in the medium was reduced, a chloride ion gradient was re-established across the cone membrane—though in a direction opposite to the normal one—and responses of inverted polarity appeared. A similar pattern of behaviour can be obtained from a retina treated with ouabain, when the sodium in the medium is reduced, as is illustrated in the second part of the record of Fig. 7.

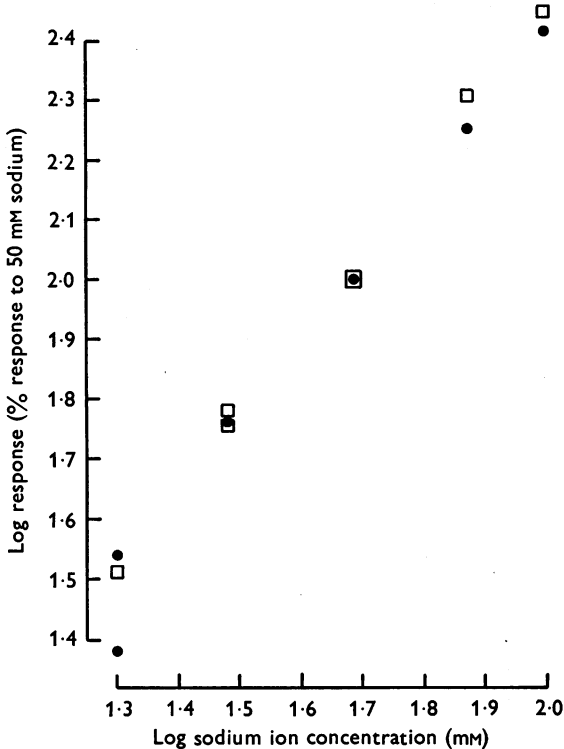

Fig. 6. Sodium dependence of cone response following ouabain treatment. Two experiments on different retinæ, indicated by circles and squares. Retinæ, maintained in a medium containing 7 mM sodium and 10^{-4} M ouabain gave no responses till exposed (for brief periods) to media containing higher concentrations of sodium. The first exposure to a standard medium (see Table 1) produced responses of amplitude equal to those recorded in a standard medium immediately before ouabain treatment. The quantity measured on the ordinate is the initial rate of increase of peak response amplitude. Note that the slope of the line joining the experimental points, on this log-log scale, is greater than 1. For further description see text.

Fig. 8 shows that the similarity of cone behaviour with respect to sodium and chloride ions is not only qualitative, but also quantitative. The retina was maintained in a medium containing 125 mM sodium chloride (medium A, Table 1) and solution changes were made either to media

with *less sodium* (medium B) and the same amount of chloride, or to media containing the same amount of sodium and *less chloride* (medium C). Tris was substituted for the sodium and sulphate for the chloride. Response

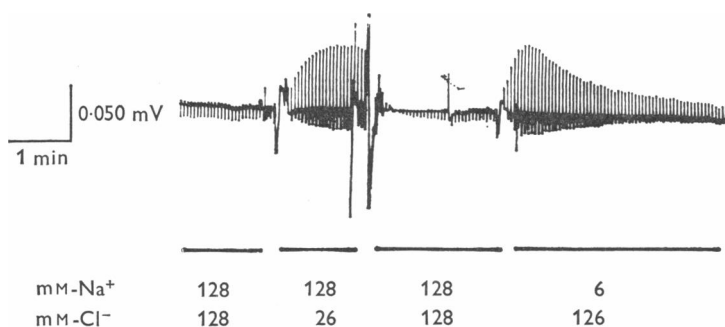

Fig. 7. Effect of removal of chloride or sodium ions from medium bathing a retina treated with ouabain. For further description see text.

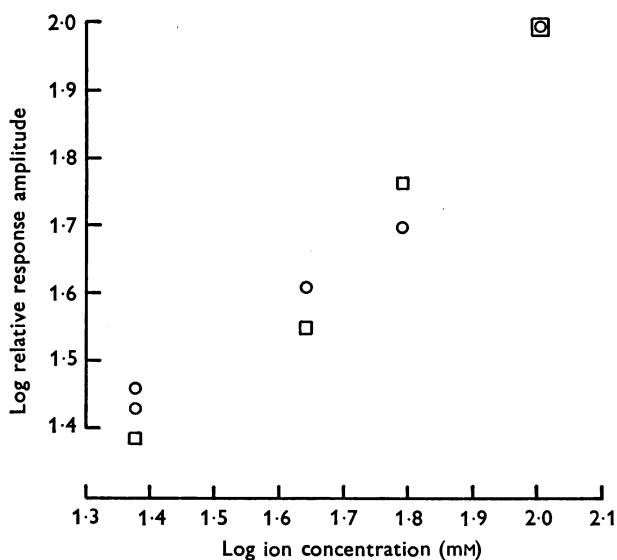

Fig. 8. Effect of reduction of sodium or chloride ion concentration. Retina maintained in a medium containing 125 mM sodium chloride. Experimental points obtained by exposing retina for brief periods to a medium in which either some of the chloride was replaced by sulphate (squares), or some of the sodium replaced by Tris (circles). For further description, see text.

amplitudes were determined in the manner described for the experiment of Fig. 5. The graph shows that equivalent reductions in either external sodium or chloride reduce the relative response amplitude to the same

extent. Note that the results are plotted on a log-log basis and can be reasonably fitted to a line of unity slope. This once again suggests that the relation between the amplitude of the receptor potential and the permeant ion concentration in the bathing medium is linear (cf. Fig. 5).

The interaction between sodium and chloride ions was investigated by comparing the dependence of the receptor potential on sodium concentration at two chloride levels. The retina was maintained in a medium similar

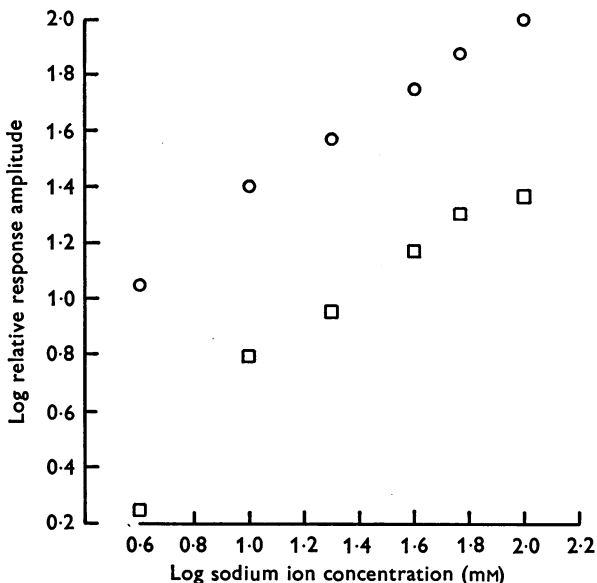

Fig. 9. Effects of reduction of sodium ion concentration with chloride concentration either 140 mM (circles) or 2 mM (squares). All points obtained from one retina: two results averaged for each point. Retina maintained in medium containing 104 mM sodium chloride. Amplitudes expressed as percentage of response for this medium.

to A of Table 1 and exposed to the test media in random order. The sodium concentration of the bathing fluid was reduced by the substitution of Tris in the test media; the chloride by the substitution of sulphate. The relative response amplitudes, obtained in a manner described for the experiment of Fig. 5, are plotted in Fig. 9 as a function of sodium concentration on a log-log basis. The relationships between response amplitude and sodium concentration at the two chloride levels are similar to each other. Thus to a first approximation sodium and chloride have a multiplicative effect on response amplitude. This also follows from Fig. 8. Note the slopes of the lines in Fig. 9 are approximately 0.6. In other types of experiment, slopes of 1 were usually found. We have no explanation for this variability, but low slopes in this type of experiment were encountered several times.

Comparison of cone behaviour to sodium, potassium and ammonium ions

Fig. 10 shows that sodium is not the only cation which can support the receptor potential. The record illustrates the effect of replacing a standard medium by solutions consisting only of Tris-sulphate mixed with sodium or potassium or ammonium sulphates, so that any responses following the changes must be attributed to the cation. In each case, after the change from the standard medium, the responses continued as large or larger than before. Note, however, that exposure to ammonium sulphate reduced the potentials that could be obtained from the retina when it was exposed once more to the standard medium.

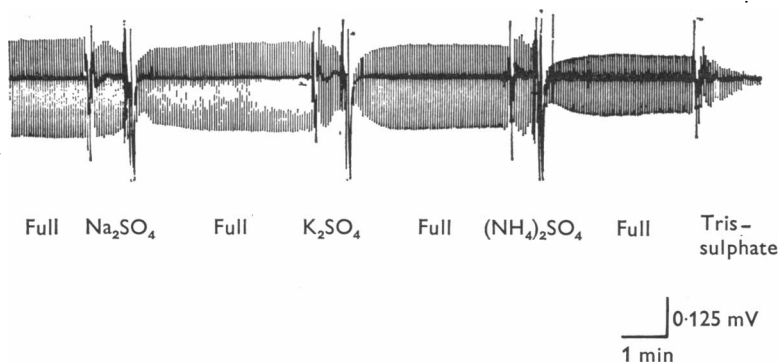

Fig. 10. Experimental record showing responses from a retina exposed to sodium, potassium and ammonium sulphates. The full medium contains approximately 60 mM sodium and chloride ions. The experimental solutions contain 100 mM of the permeant cation plus Tris and sulphate to make up the osmolarity. Traces retouched.

The similarity in behaviour of the cones to sodium, potassium, and ammonium ions was investigated quantitatively in two experiments the results of which are summarized by Table 2. In both experiments the retinae were maintained in standard media. In one experiment the retina was briefly exposed to media containing equivalent amounts of the different cations and the same amount of other ingredients. The other experiment was identical except that media with fewer ingredients were used and some of these included mixtures of the cations. For each medium the response amplitude was calculated as a percentage of the response from the retina in the standard medium. As can be seen from the Table, the values for the media are equal to one another within the limits of experimental error. Such results, particularly those obtained from the cation mixtures, imply that the cones do not distinguish between sodium, potassium and ammonium ions, at least in the short term. The amplitude of the responses would appear to depend on the total cation concentration.

TABLE 2. Response of retinae exposed to different cations

Solution Standard	NaCl (mM)	KCl (mM)	NH ₄ Cl (mM)	Total permeant cation (mM)		Tris-Cl (mM)	Other substances (mM)	Relative response amplitude	No. of observations	S.D.
				27.5	105					
		2.5	—		Retina I		79	100	—	—
I	80	—	—	80	90	—	—	115	5	13
II	20	60	—	80	90	—	—	117	5	6
III	20	—	60	80	90	—	—	119	5	3
					Retina II					
IV	125	2.5	—	127.5	—	—	79	147	2	—
V	—	127.5	—	127.5	—	—	79	131	2	—
VI	—	2.5	125	127.5	—	—	79	144	2	—
VII	62.5	65	—	127.5	—	—	79	144	3	—
VIII	62.5	2.5	62.5	127.5	—	—	79	156	2	—
IX	—	65	62.5	127.5	—	—	79	155	2	—
X	50	40	37.5	127.5	—	—	79	183	2	—

To investigate this point further, response amplitude was studied as a function of both sodium and potassium concentration. The retina was maintained in a medium containing 28 mM sodium and 2.5 mM potassium and was briefly exposed to media with either more sodium and the same amount of potassium, or the same amount of sodium and more potassium (mixtures of media A, B, and D). The test media were presented in random order. Relative response amplitudes were determined in the manner

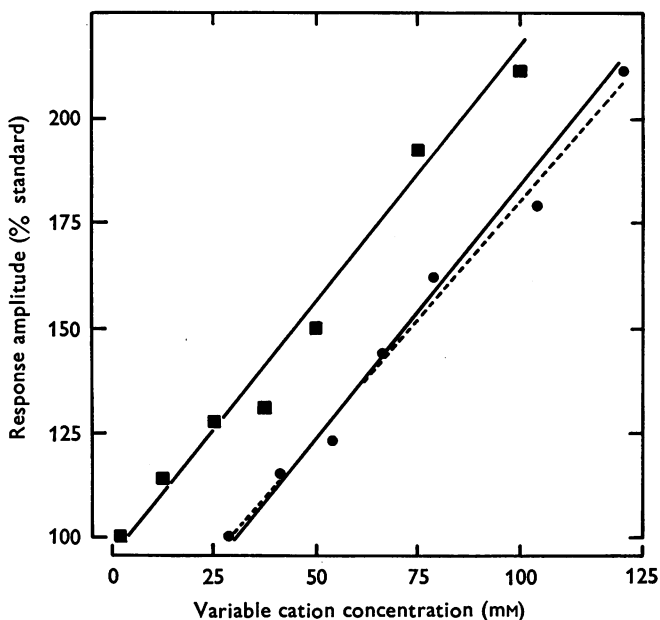

Fig. 11. Response amplitudes in media containing varying concentrations of potassium (squares) or sodium (circles). The retina was maintained in a medium containing 2.5 mM potassium and 28 mM sodium. This response amplitude was taken as 100%. The ordinate shows the increases in response produced by substituting potassium or sodium chloride for some of the Tris-chloride. The heavy line through the squares is a calculated regression line. The dotted line is the regression line calculated for the circles. For further description, see text.

previously described. The results are plotted in Fig. 11 on a linear-linear basis. Each point is the mean of two determinations. Note that the relationship between relative response amplitude and ion concentration is very similar for the two ions and that for sodium is very like the one described for Fig. 5. If the effects of the two ions were additive, the amplitude of the responses would depend upon the total cation concentration and the potassium points could all be shifted to the right of the graph by a distance corresponding to the constant sodium concentration in the potassium

media. Regression lines have been calculated for the sodium and potassium data: the continuous line drawn through the circles is the potassium line shifted by a distance corresponding to a sodium concentration of 28 mM. It is evident that this line very nearly coincides with the dotted sodium line.

Figs. 10 and 11 and Table 2 show that both qualitatively and quantitatively sodium, potassium and ammonium on their own and in mixtures behave very similarly in supporting the cone potential. The similarity

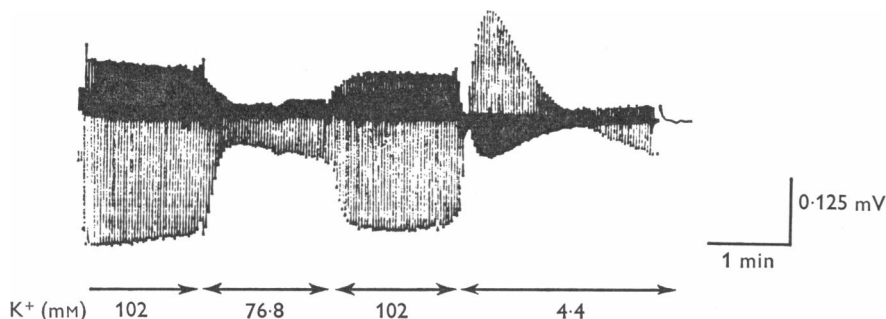

Fig. 12. Responses of retina maintained in a potassium chloride medium. Note reduction of potassium concentrations causes reduction or inversion of responses. For further description, see text.

suggests that all three ions are in lower concentration within the cone than would be in equilibrium with the outside for the potential across the membrane, a conclusion hardly surprising in the case of sodium and ammonium but rather unusual in the case of potassium. It might be argued that our experimental procedures deplete the potassium inside the cone and indeed the strict quantitative similarity between sodium and potassium is found only when the retina is maintained in media containing relatively low amounts of sodium. Thus, for instance, if the retina is maintained in a medium containing 125 mM sodium and this is all replaced by potassium, there is an immediate decrease in the response amplitude which only partially recovers its former size with time in the potassium medium. Yet even in such a medium, which favours the accumulation of potassium within the cone, at a qualitative level, the cones continue to behave as if the external ion were sodium, as can be seen from the record shown in Fig. 12. So, unless *ad hoc* hypotheses are advanced, the conclusion is unavoidable that either the potassium concentration in the cone is much lower than in most neurones, or that the membrane of the cone does not distinguish between sodium and potassium.

Cone potentials from retinæ in lithium media

Sillman, Ito & Tomita (1969) have reported that lithium cannot substitute for sodium in the production of the receptor potentials of frog receptors. Fig. 13 shows that this clearly is not true for pigeon cones. The retina was maintained in a medium consisting only of Tris-chloride (medium H) and briefly exposed in turn to a sodium chloride/Tris-chloride solution, then a lithium chloride/Tris-chloride one (medium J), and finally to the first

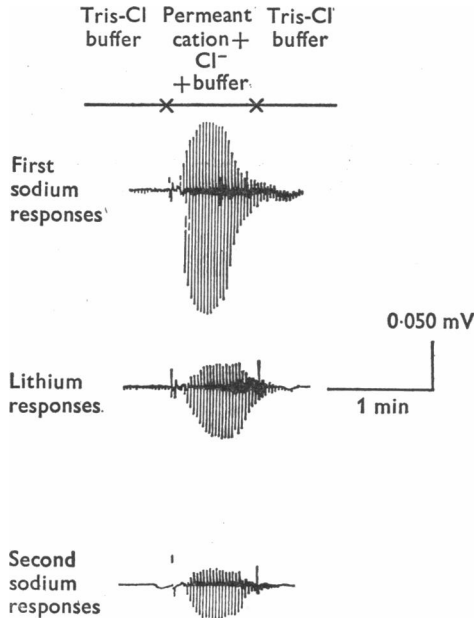

Fig. 13. Sections of experimental record showing responses to lithium ions (60 mM), compared with responses to sodium ions (60 mM). The retina was maintained in a Tris-chloride medium. The exposures to the permeant cations were separated by more than 5 min. For further explanation, see text.

solution again. The response amplitude declines with each exposure to a permeant cation; so the lithium responses were intermediate in size between the first and second sodium ones. However, in other experiments it has been observed that prolonged exposure of the retina to media containing lithium causes the responses to decline to a very small size. Replacement of the lithium by impermeant ions such as Tris never produces responses of inverted polarity, even when the retina has been treated with ouabain. In this respect lithium has quite different effects from sodium, potassium and ammonium. Replacement of the lithium by sodium does not lead to the

immediate restoration of large potentials but to a slow recovery of the response amplitude. These observations indicate that lithium, whilst transiently capable of supporting cone potentials, eventually blocks the responses.

Cone potentials in media containing anions other than chloride

Responses can continue in the presence of a variety of anions other than chloride, just as they can in the presence of cations other than sodium. This is illustrated in the record of Fig. 14. The retina was maintained in a medium containing 104 mM sodium chloride and was briefly exposed to media containing 100 mM sodium bromide or sodium nitrate or sodium

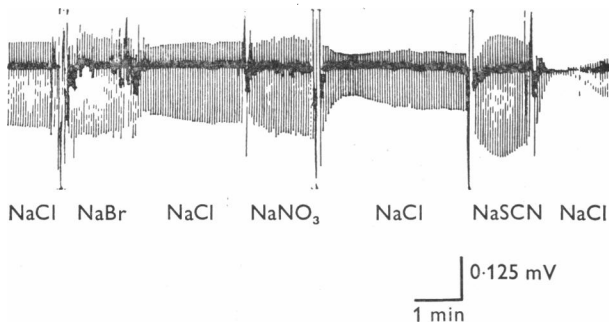

Fig. 14. Record showing responses to foreign anions. All media contained 104 mM sodium, 100 mM anion, 4 mM chloride, plus Tris-sulphate buffers. For further description, see text.

thiocyanate. The conductivities of the media with the foreign anions were up to 10% lower than that of the sodium chloride one, which explains some of the apparent increase in size of the responses. However, if that is taken into account, it is clear that the retina continued to give responses as large, or in the case of the thiocyanate medium larger than, before.

Analogous experiments have been performed in solutions from which a permeant cation was missing. Fig. 15 illustrates some of the results. In record 1, the retina had been kept for 29 min in a medium (H) containing Tris-chloride and EDTA (analysis of the medium after the experiment showed that the sodium concentration was 0.15 mM). Small responses were still present. When the medium was changed to one containing Tris-sulphate and EDTA (I) (analysis showed that the sodium content was also 0.15 mM), there was a disturbance to the trace, owing to the change in electrode potential. Following this, the responses were absent. The noise was higher, because of the lower conductivity of Tris-sulphate. In record 2, from another experiment, a retina was maintained in Tris-sulphate (medium I) until all responses vanished. Then the retina was exposed to

choline bromide (medium E) and responses reappeared. In such experiments, the electrodes became noisy, apparently as a result of the effect of the bromide ion on them. Experiments were also performed with choline iodide, but in these, electrode noise was so great that responses could only be discerned on the oscilloscope screen. When the medium was changed from choline bromide to Tris-sulphate, small inverted responses appeared but soon died away.

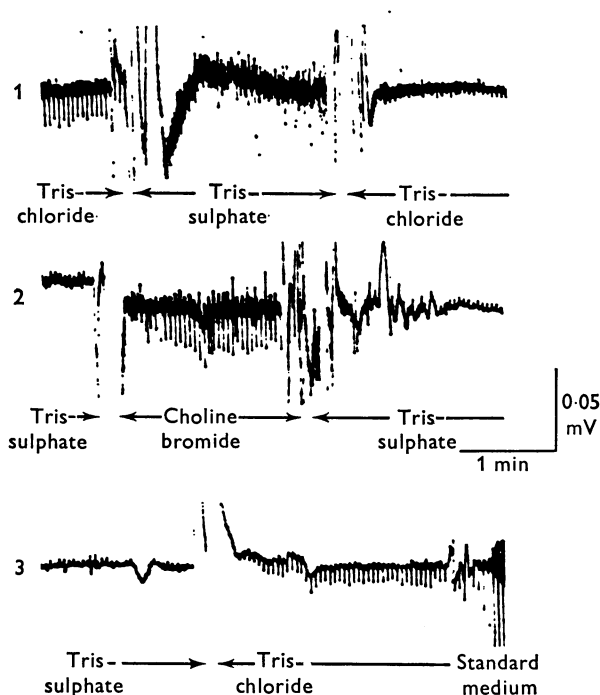

Fig. 15. Responses of retinae in media deficient in cations. Three records: (1) retina maintained in Tris-chloride for 29 min. Note responses return slowly after treatment with Tris-sulphate; (2) shows bromide is a substitute for chloride; (3) continuation of (2). Responses return in Tris-chloride when $[\text{Na}^+]_{\text{out}} < 10^{-5}$ M. Note the large disturbances caused by medium changes. Electrode noise also increases in sulphate and bromide solutions.

The retina was then exposed to a pure Tris-chloride solution (H), in which the sodium concentration was less than 0.01 mM. Responses appeared promptly although they were smaller than in medium E. This is probably due to the lack of EDTA in the medium. In other experiments (not illustrated) media similar to H were made in which the very small sodium concentration was produced by adding either sodium chloride or EDTA. Retinae in the latter medium produced responses 50% larger than

in the former. The retinae were finally exposed to the standard medium. The record shows the responses returning. When fully recovered, they were 10–15 times larger than those in solutions E or H.

Wave form changes and intensity–amplitude relationships for different media

Fig. 16 shows that, although the wave form of cone responses gradually becomes more prolonged during the course of an experiment, there are no specific changes of wave form associated with a change to a given medium.

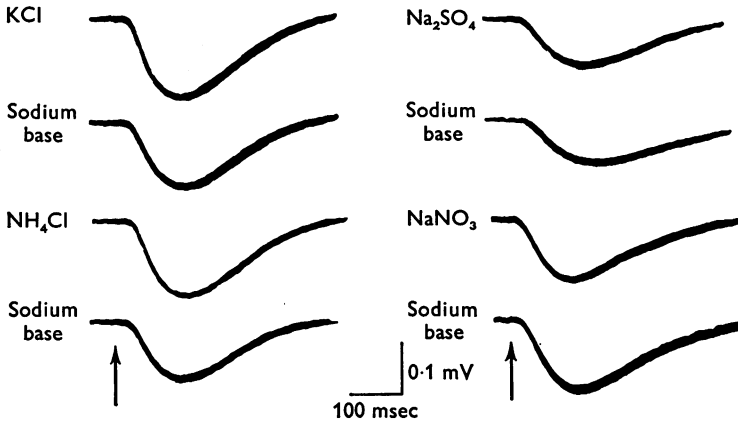

Fig. 16. Wave forms of responses in media of differing composition. The 'KCl,' 'NH₄Cl' and 'Na₂SO₄' responses were obtained during the course of one experiment. In between exposures to these media (approximately 120 mM plus Tris buffers to maintain osmolarity) the retina was returned to the standard medium. Note that the responses gradually become more prolonged and smaller as the experiment continues: this affects responses in the standard medium and in the unusual media to the same degree.

Crucial to the interpretation of the present study is the assumption that changes in response amplitude following changes in media result from alterations in the voltages of the ionic batteries in the cone membrane. Thus in most experiments responses to a single light intensity have been considered sufficient to characterize the effects of different media. To confirm this point four sets of successive amplitude/intensity measurements were made at two levels of sodium concentration. The flashes were more prolonged than usual (50 msec as opposed to 15 msec) so that higher effective stimulus intensities were available. The assumption of changes in membrane potential requires that when the measurements are plotted on logarithmic scales, the curves can all be brought into coincidence by vertical shifts. Fig. 17 shows an attempt to do this for the four sets of measurements. Coincidence is good over approximately 1.4 log units at the lower intensities. Note that the usual stimulus intensity used

in our experiments corresponds to an abscissa value of $\bar{2}\cdot1$ which lies in this range. At higher intensities the curves differ in shape owing to a disappearance with time of saturation and this disappearance can be seen in responses obtained at both levels of sodium concentration. The loss of the flat bottom characteristic of saturated responses is illustrated in Fig. 18.

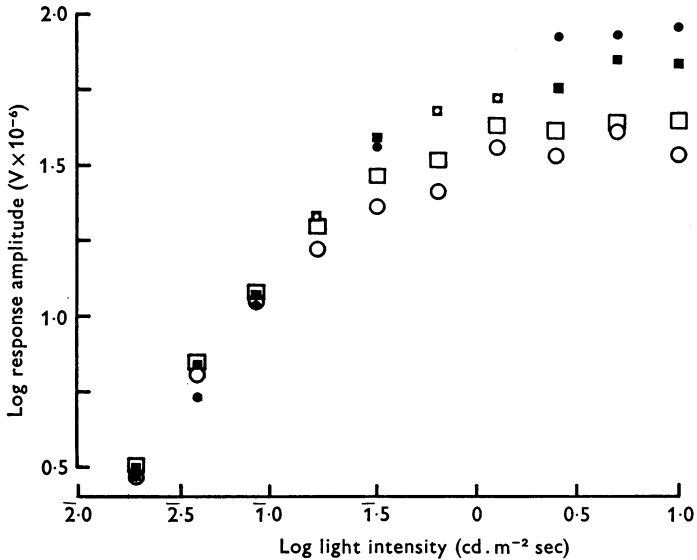

Fig. 17. Amplitude/light intensity measurements at 85 mM sodium (squares) and 4 mM sodium (circles). Two pairs of curves are shown: the second experiment (filled symbols) was performed approximately 3/4 hr after the first. The points have been displaced vertically so that the best fit is obtained for the lower light levels. The ordinate scale is given for the filled circles. For open circles, add 0.33. For open squares, add 0.94. For filled squares, add 0.63. Further description in text.

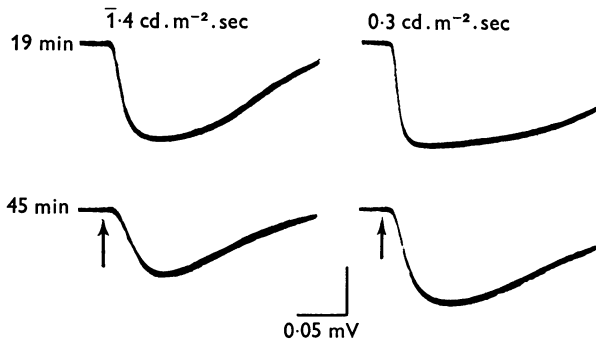

Fig. 18. Wave forms of responses for two saturating light intensities. Retina maintained in a standard medium. Note alteration of wave form with time.

The effect of EDTA

Most of the experiments reported here involved the use of EDTA in the media (see Table 1). Occasional experiments done without EDTA suggest that this ingredient has an important effect on the nature of the results either directly, or indirectly by chelating calcium ions. For example, in the absence of EDTA it was difficult to obtain responses of inverted polarity in circumstances where they are usually seen. Furthermore, after ouabain treatment the cones only produced large responses to changes in sodium concentration and not to changes in potassium, ammonium, or lithium concentrations.

DISCUSSION

In the present study, although we have measured light-induced changes in the current flowing outside the receptors, we can deduce some of the electrical properties of the membranes of the outer and inner limbs, if we combine our results with those of Toyoda *et al.* (1969) and Baylor & Fuortes (1970) who have measured the voltage across the cone inner limb membrane.

Linearity of system and quantitative results

The results of our experiments, and those of other workers, are consistent with the idea that there is only one light-sensitive voltage source which is in the outer limb. If the longitudinal intracellular resistance of the cone or the outer or inner limb membrane resistances (see Fig. 1) were affected by ions, or were voltage dependent, our measurements of extracellular current would not be linearly related to changes in the outer limb battery. However, the same response-amplitude/concentration function was obtained for sodium, potassium and chloride ions, in spite of the fact that changes in the concentrations of these ions probably affected the outer and inner limb membrane potentials in different ways. Further, Baylor & Fuortes (1970) have found that when the membrane voltage is disturbed by injecting current into the cone the membrane resistance does not vary. These authors have also described a membrane voltage/light intensity relationship which is the same as our response-amplitude/light intensity function. This is shown in Fig. 19. A common interpretation of the results shown in Fig. 19 is that light operates on a series of parallel conductances which are all connected to a single fixed conductance. The saturation level of the system is determined by the value of the fixed conductance. In our experiments (Fig. 17) the light intensity at which saturation becomes apparent may change with time, but is independent of the permeant ion concentration of the medium. This means either that the resistances of the circuit

are independent of changes in ion concentration of the extracellular medium, or they all change in the same proportion. It therefore seems reasonable to relate our measurements of current to changes in membrane potential. Empirically we find, for a variety of conditions, including the presence of ouabain in the medium, that response amplitude, R , is given by

$$R = k[\text{Na}_0^+]^n \cdot [\text{Cl}_0^-]^n, \quad (1)$$

where k is a constant dependent upon the composition of the standard medium; and n is a constant for a given experiment, and usually has a

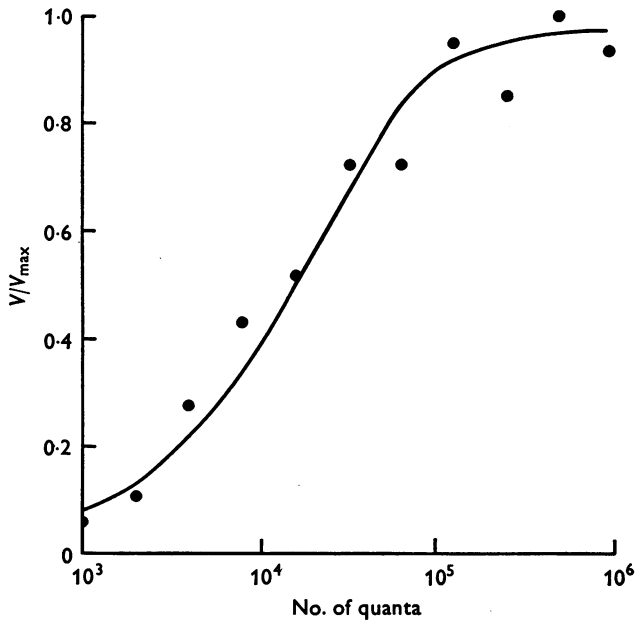

Fig. 19. Amplitude/intensity functions of cones. The points are the open squares of Fig. 3, replotted as a fraction of maximum response amplitude. The line shows changes in inner limb membrane potential in turtle cones (Baylor & Fuortes, 1970). The abscissa, log quanta incident per flash per cone, is common to both sets of data.

value close to unity. This relationship is quite different from that which would be expected if the voltages in the circuit we propose (Figs. 1 and 2) were given by Nernst or constant field equations (Goldman, 1943). Various explanations may be given for the discrepancy: for example, the internal composition of the cone may change as rapidly as we can affect the concentration of ions in the boundary layers outside the membrane. It is of course possible that the cone membrane is more complex than the simple model membranes for which electrochemical theory has been worked

out (Plonsey, 1969). Nonetheless, we have found it convenient to use such theory in a qualitative interpretation of our results.

Cation and anion batteries

The present study demonstrates that the circuit shown in Fig. 1 must be modified. The fact that the behaviour of potassium and ammonium ions is analogous to that of sodium implies that the specific sodium battery must be replaced by a general cation battery. If the voltage of this battery (E_{cat}) were of the form

$$E_{\text{cat}} = \frac{RT}{F} \ln \frac{\sum P_i C_i'}{\sum P_i C_i''} \quad (2)$$

where R , T and F have their usual significance; P_i is the permeability of the membrane to the i th cation; and C_i' and C_i'' are the concentrations of the i th cation in the extracellular and intracellular media respectively; then the results of Figs. 10 and 11, and Table 2 require that the membrane should have the same permeability to potassium and ammonium ions as it does to sodium. In this respect the effects of potassium ions are unlike those observed in most excitable tissues, for here they can be lumped with those of sodium in a single battery. This role for potassium is strikingly different from that proposed for rods by Sillman *et al.* (1969).

The role of chloride cannot be accounted for by postulating that the outer limb battery of Fig. 1 is a general ion battery, the voltage of which is given by an equation of the Goldman (1943) form. In such an equation the concentration of anions in the extracellular medium would enter the denominator of eqn. (2), i.e. a decrease in the concentration of extracellular chloride should increase the response amplitude, which is the opposite of what is observed. In fact, the analogous behaviour of the receptors to sodium and chloride ions, although these are oppositely charged (see Figs. 7 and 8) and the multiplicative form of the function relating response-amplitude to the concentrations of these ions (Fig. 9 and eqn. (1)) strongly suggests that if sodium has its predominant effect on membrane potential in darkness, then chloride has its predominant effect in light.

It is possible that the inner limb battery, B in Fig. 1, is in fact the chloride battery. How this scheme might work will be discussed later. Our results indicate that, since foreign ions such as bromide, nitrate, or thiocyanate can be substituted for chloride, a general anion battery should be envisaged, similar to the general cation battery already proposed. For simplicity, however, only sodium and chloride ions will be considered in the discussion below.

Cone membrane potentials

It is known that the cone membrane resistance increases in light, and the membrane hyperpolarizes (Toyoda *et al.* 1969; Baylor & Fuortes, 1970). In terms of our modified Fig. 1 this means that the membrane potential moves in the range between the sodium and chloride equilibrium potentials. If the micro-electrode measurements refer to the outer limb itself, it can be assumed that in light, the conductance of the outer limb membrane

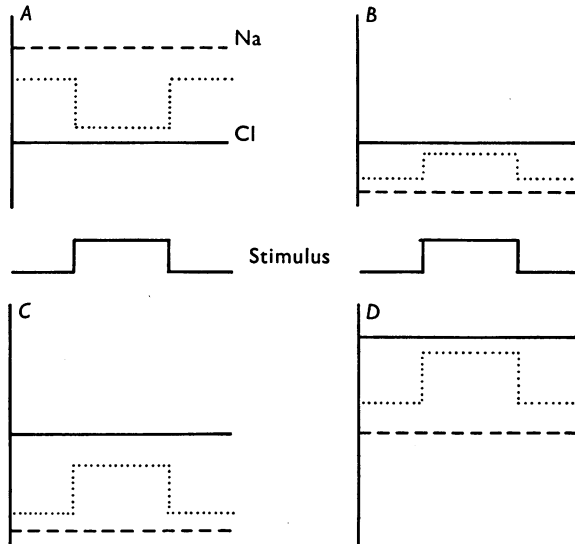

Fig. 20. Suggested changes in outer limb membrane potential. The dashed and continuous lines represent the sodium and chloride equilibrium potentials. The dotted lines show how the cone membrane potential alters in light (stimulus). The ordinate is in arbitrary units, but the range of the voltages shown in *A*, *B*, *C*, *D*, is the same. Conditions: *A*, response in normal medium; *B*, response in low sodium medium; *C*, *D*, retina treated with ouabain, equilibrated in standard medium: *C*, immediately after reduction of sodium, *D*, immediately after reduction of chloride.

decreases, and the membrane potential approaches that of the inner limb. Such a scheme is outlined in Fig. 20. The membrane potentials are shown for various ionic conditions. No numerical values have been inserted (in view of the reservations we made about our quantitative results), but the ordinate scales of *A*, *B*, *C*, and *D* all indicate the same range of membrane potential. In *A*, the membrane voltage changes are shown for a standard medium. *B* represents the conditions when inverted responses are seen with media containing little sodium: E_{Na} is now more negative (inside with respect to outside) than E_{Cl} . After treatment with ouabain

(*C*, *D*) the sodium and chloride potentials both change and approximate to each other, and responses disappear. If sodium in the medium is now removed (*C*), or chloride (*D*), similar inverted responses appear, though the membrane potentials are very different in the two cases.

In media containing 3–4 mM sodium, the inverted responses (Fig. 21 *B*) are soon replaced by those of normal polarity. We may suppose that under these conditions, sodium leaves the cone, together with chloride. E_{Na} will become less negative, and E_{Cl} more negative, till the two levels of potential cross and stand in the same relation as in Fig. 21 *A*. However, the response will be smaller, and the range of potential over which the membrane operates will be more negative than that for the standard medium.

Equilibrium potentials and permeability changes

Baylor & Fuortes (1970) found the membrane potentials of the inner limbs of turtle cones to be approx. -30 mV in darkness, and -45 mV in light. If these figures apply also to pigeon cones, then E_{Cl} must be equal to or more negative than -45 mV. When current (j , Fig. 21 *A*) was injected into the cone, the responses to light reduced in amplitude and vanished when the membrane voltage, V_m , was zero. Further depolarization caused the responses to invert. Baylor & Fuortes (1970) explained their results with the model of Fig. 21 *A* but they are equally compatible with the model we are proposing (Fig. 21 *B*). By applying Kirchoff's laws and Ohm's law to the circuit of Fig. 21 *B*, we derive the following equation

$$g_{\text{Na}}(E_{\text{Na}} + V_m) = g_{\text{Cl}}(E_{\text{Cl}} - V_m) + j. \quad (3)$$

Most of our results can be explained on the basis that g_{Na} alone alters in light. Equation (3) predicts that light responses would disappear when $V_m = E_{\text{Na}}$, which in Baylor & Fuortes' experiments occurs at zero membrane potential. Thus the cation concentration of the cone would equal that of the medium outside, and the membrane potential, both in light and in darkness, would be produced by a very considerable deficit in internal permeant anions. In this situation *A* and *B* of Fig. 21 would become identical. It seems very unlikely that such conditions can occur in our experiments, where sodium and chloride may accumulate in the cones. Apart from species differences, one explanation seems plausible, viz. that the internal composition of the cones can be changed considerably by injected current. If the internal volume of a cone is represented by a cylinder 5μ in diameter and 50μ long (and this is almost certainly an over-estimate) then the volume will be ca. 10^{-12} l. The current injected (2×10^{-9} A) to reduce the membrane voltage to zero will introduce about 2×10^{-14} mole of

cation per second, and so could rapidly change the composition of the intracellular fluid.

Equation (3) shows that if both cation and anion permeabilities altered with illumination, the responses would not disappear at any membrane voltage. For this reason we postulate that light only causes a decrease in cation permeability. However, this hypothesis encounters difficulties when results such as those of Fig. 15 are considered. In these experiments the sodium concentration of the extracellular medium is 10^{-5} M or less. To obtain a response of normal polarity under these conditions, it must be

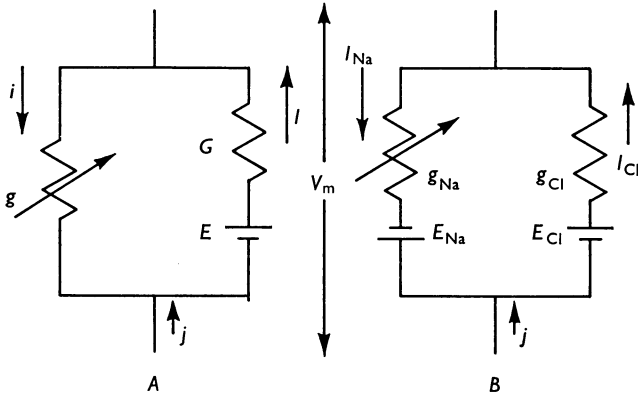

Fig. 21. *A.* Baylor & Fuortes' (1970) model of the cone. *B.* The modifications suggested by the result of this paper. The circuit elements occur in the membrane, the voltage of which is V_m . A micro-electrode injects current (j) into the cone. For further description, see text.

assumed that the internal concentration of cations is very low. Therefore the concentration of intracellular anions must also be low and E_{Cl} very negative. Hence removal of chloride ions from the medium should result in the appearance of large inverted responses. Fig. 15 shows that if inverted responses do appear, they are very small. This is not due to damage to the receptors which subsequently produce large responses in normal media. The lack of responses in Tris-sulphate also enables us to eliminate one possible interpretation of the results, namely, that in media deficient in sodium, the membrane potential in darkness is held not near E_{Na} but at another cation equilibrium potential (possibly E_{Tris}) which is slightly less negative than E_{Cl} , and that light causes a decrease in the membrane permeability to this cation.

Alternatively, it is possible that in media from which permeant cations are excluded, the cone membrane potential in darkness is slightly less negative than E_{Cl} , and a very small active increase in anion permeability in light causes the outer limb to hyperpolarize (Arden & Ernst, 1970).

This work was supported by grants from the Medical Research Council. It was partly carried out while W.E. held a M.R.C. Research Fellowship.

REFERENCES

- ARDEN, G. B. & ERNST, W. (1969*a*). Effect on the electroretinogram of change in the ionic composition of the fluid bathing the isolated avian and mammalian retina. *J. Physiol.* **201**, 58*P*.
- ARDEN, G. B. & ERNST, W. (1969*b*). Mechanism of current production found in pigeon cones but not in pigeon or rat rods. *Nature, Lond.* **223**, 528–531.
- ARDEN, G. B. & ERNST, W. (1969*c*). Different current generators in rods and cones. *J. Physiol.* **204**, 35–36*P*.
- ARDEN, G. B. & ERNST, W. (1970). Anion and cation currents in pigeon cones. *J. Physiol.* **209**, 41–42*P*.
- BAYLOR, B. A. & FUORTES, M. G. F. (1970). Electrical responses of single cones in the retina of the turtle. *J. Physiol.* **207**, 77–92.
- BRINDLEY, G. S. (1956). The passive electrical properties of the frog's retina, choroid and sclera for radial fields and currents. *J. Physiol.* **134**, 339–352.
- BROWN, K. T., WATANABE, K., MURAKAMI, M. (1965). Early and late receptor potentials of Monkey Cones and Rods. *Cold Spring Harb. Symp. quant. Biol.* **30**, 457–482.
- GOLDMAN, D. E. (1943). Potential, impedance and rectification in membranes. *J. gen. Physiol.* **27**, 37–60.
- PENN, R. D. & HAGINS, W. A. (1969). Signal transmission along retinal rods and the origin of the electroretinographic a-wave. *Nature, Lond.* **223**, 201–205.
- PLONSEY, R. (1969). *Bioelectric Phenomena*. N.Y.: McGraw-Hill.
- SILLMAN, A. J., ITO, H. & TOMITA, T. (1969). Studies on the mass receptor potential of the isolated frog retina. II. On the basis of the ionic mechanism. *Vision Res.* **10**, 1443–1451.
- TOYODA, J., NOSAKI, H., & TOMITA, T. (1969). Light induced resistance changes in single photoreceptors of *Necturus* and *Gekko*. *Vision Res.* **9**, 453–463.