

PROCEEDINGS OF THE PHYSIOLOGICAL SOCIETY

CAMBRIDGE MEETING

15 July 1966

DEMONSTRATIONS

A simplified automatic device for the performance of antidiuretic assays

BY R. E. J. DYBALL, G. J. LANE and R. G. MORRIS. *Department of Pharmacology, Medical School, University of Bristol*

Several methods for the automatic recording of the rate of urine flow while maintaining an experimental animal at a uniform water load have been devised (Boura & Dicker, 1953; de Wied, 1960; Fang, Liu & Wang, 1962). Since the apparatus used by all these workers was complicated, it

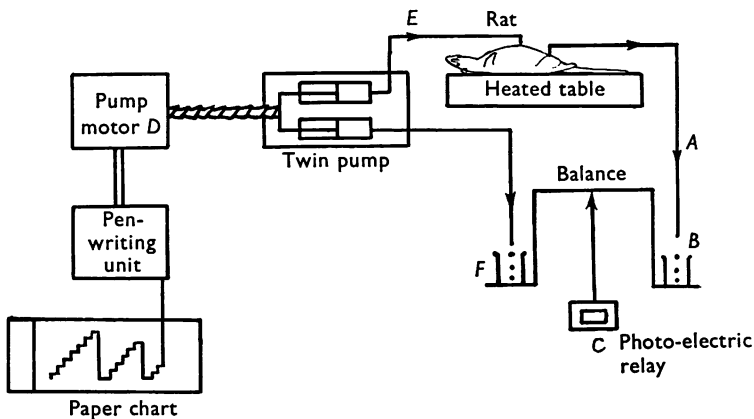

Fig. 1. Diagram of apparatus for the performance of antidiuretic assays.
For explanation see text.

was decided to devise a simpler, more compact unit. Previously either the volume of urine produced or its conductivity (Albers & Brightman, 1959) was used to make a continuous assessment of urine flow rate. Our apparatus (Fig. 1) records the weight of urine produced in unit time which is related directly both to the volume and specific gravity.

Urine is led from the rat's bladder by a cannula (A) to a beaker (B) on one pan of a balance. As a drop falls, the balance arm swings away from its

resting position and a vane shutter attached to the pointer interrupts a light beam. This activates a photo-electric relay (*C*) which switches on the electric motor (*D*) driving a pump with twin outlets. One of these (*E*) leads into the rat's stomach and the other to another beaker (*F*) on the second pan of the balance. The pump delivers fluid until the beaker (*F*) on the second pan is slightly heavier than that on the first. The balance arm then swings back and the photo-electric relay switches off the pump. Thus the rat is maintained at an almost constant water load. The balance used responds to one drop of urine (about 0.02 ml.).

The flow rate is recorded from the pump. There is a notched wheel on the drive shaft from the motor and, as the shaft revolves, a pawl engaging with the notches leads, by a series of levers, to a stepwise deflexion of a pen writing on a paper chart, each step corresponding to approximately 0.02 ml. At the end of each $2\frac{1}{2}$ min period the pen is returned to the base line so that the record gives a measure of urine flow rate in unit time. The pen-writing unit is incorporated in the apparatus.

REFERENCES

- ALBERS, R. W. & BRIGHTMAN, M. W. (1959). *J. Neurochem.* **3**, 269–276.
BOURA, A. & DICKER, S. E. (1953). *J. Physiol.* **122**, 144–148.
FANG, H. S., LIU, H. M. & WANG, S. S. (1962). *Am. J. Physiol.* **202**, 212–216.
WIED, D. DE (1960). *Acta physiol. pharmac. néerl.* **9**, 69–81.

Acetylcholine release from the brain of the conscious rabbit

BY B. COLLIER* and J. F. MITCHELL. *University Department of Pharmacology, Cambridge*

Experiments on anaesthetized animals have shown that, in the presence of an anticholinesterase, acetylcholine (ACh) is released from the cerebral cortex at a rate which is affected by the depth of anaesthesia. Stimulation of sensory pathways or specific thalamic nuclei increases the output of ACh and there is evidence that the ascending reticulo-cortical (arousal) pathway and the thalamo-cortical pathway, responsible for augmenting and after-discharge responses, are associated with cholinergic fibres ending in the cortex (Mitchell, 1963; Collier & Mitchell, 1966).

Although this, together with other evidence, may suggest a central transmitter role for ACh concerned with arousal mechanisms, the release of ACh from the cortex of conscious, free-moving animals has not been previously investigated.

In the present experiments rabbits were anaesthetized with thiopentone

* M.R.C. Junior Research Fellow. Present address: Department of Physiology, McGill University, Canada.

sodium and a perfusion system implanted through the skull so that a small volume of cortical tissue was perfused continuously. The rabbits were allowed to recover from the anaesthetic and the perfusate collected for 8–10 hr from the conscious, free-moving animals. The implanted perfusion tubes were filled with Ringer–Locke solution containing eserine (400 $\mu\text{g}/\text{ml.}$) and atropine (0.4 $\mu\text{g}/\text{ml.}$) and attached by flexible tubes to an infusion pump and a collecting vessel. Perfusion was started before the animals had recovered from the anaesthetic and the perfusate was removed and assayed for ACh when 0.5 ml. had collected (approximately every 15 min). The first samples were obtained as the animals recovered from the anaesthetic and contained 10–30 ng ACh/collection period, but when the animals were fully recovered and began to explore, the ACh output rose to 70–120 ng/collection period. This high rate of release was maintained while the animals were active, sometimes for as long as 3 hr. During periods when the animals were inactive the ACh release fell to 20–50 ng and if the animals were persuaded to play during one of these periods the release of ACh rose until the animals again rested.

Pentobarbitone (Nembutal) (30 mg/kg, i.v.) produced an immediate fall in ACh release (to 8–15 ng/collection period) and after death (Nembutal, 65 mg/kg, i.v.), the ACh output fell to undetectable levels (< 1.0 ng).

These experiments suggest that the cortical release of ACh is not confined to anaesthetized animals and that it is affected by changes in levels of consciousness and activity.

This work was supported by grants from the Royal Society and the Medical Research Council.

REFERENCES

- COLLIER, B. & MITCHELL, J. F. (1966). *J. Physiol.* **184**, 239–254.
MITCHELL, J. F. (1963). *J. Physiol.* **165**, 98–116.

A constant pressure variable flow blood perfusion system

By R. D. LOWE. *Department of Medicine, St Thomas's Hospital Medical School, London, S.E. 1*

This servo-system provides a versatile method of perfusing at a constant pressure, isolated organs or part of the intact animal, using simple adaptations of commercially available equipment. A 'Servomex' MC47 Speed Controller and Motor drives a 'Sigmamotor' T6S pump through a 5 to 1 worm reduction gear. The output pressure of the pump is registered by a pressure transducer ('Devises' or 'Statham'); the signal is amplified by a DC differential amplifier ('Fenlow' Type 103/S), and fed back to the motor controller to regulate the speed of the motor, replacing the negative velocity feed-back of the generator on the motor shaft. The dimensions

of the tubing in the pump are selected so that the desired flow rates are obtained at a motor speed of about 2000 rev/min.

The open loop gain of the system is over 200 to 1, the frequency response is 0.6 to 0.15 c/s and the range of flow from 0 to 8 l. per minute at pressures of up to 750 mm Hg. The highest frequency response is obtained with low flow rates (10–100 ml./min) and with the output pressure recorded close to the pump.

The three main problems in developing the system were: (1) The output of the pump is pulsatile, and the feed-back signal had to be damped (time constant 200–800 msec) to smooth these oscillations. (2) With pressure feed-back only, the servo system was unstable and developed oscillations. To stabilize the system the generator voltage was utilized to provide viscous damping by negative velocity feed back through a capacitor. (3) The common negative line of the Motor Controller is not earthed and the output of the D.C. amplifier could not be connected directly to it but had to be chopped, passed through a transformer and rectified before reaching the Motor Controller.

The characteristics of the perfusion system allow its use in biological experiments where its low frequency response is not an important drawback. For auto-perfusion of innervated organs when the circulatory reflexes are intact the system only operates satisfactorily when the area of perfusion does not represent a large fraction of the total peripheral resistance of the animal; if this condition is not fulfilled variations of pump output cause inverse variations in arterial pressure and large oscillations of both occur by the following mechanism: a spontaneous rise of systemic arterial pressure activates cardiovascular reflexes which lower the peripheral resistance of the perfused organ; the pump therefore increases its output, which lowers the arterial pressure; the response time of cardiovascular reflexes summates with that of the servo-system so that the change of pump speed lags the change of arterial pressure by several seconds, and oscillations are perpetuated at intervals of twice the lag-time.

The perfusion system has proved satisfactory for constant pressure auto-perfusion of innervated dogs kidneys, of the femoral artery *in situ*, and of the carotid sinuses.

Thanks are due to R. C. Steel of Servomex Controls Ltd. and to Peter Styles, for advice and help; to Mr Zabikowski for assistance in construction, and to the Medical Research Council for the costs of the apparatus.

A direct method of measuring the rate of entry of sperm into sea urchin eggs

By P. F. BAKER and R. PRESLEY. *The Physiological Laboratory and Anatomy School, Cambridge*

The successful measurement of fertilization rate requires a method for separating sperm from eggs after a given time, together with some means of assessing the extent of fertilization and polyspermy. Functional separation of sperm from eggs has been reported following immersion in hypotonic sea water (Rothschild & Swann, 1951) or in sea water containing lauryl sulphate (Hagström & Hagström, 1954). In our hands, 30% sea water has proved satisfactory and has been used throughout the present experiments; but results obtained with this one technique must remain suspect until they have been confirmed using a second method of sperm inactivation. This is particularly important as it is not known at which point in its interaction with an egg a sperm becomes immune to hypotonic solutions.

In the past, the extent of fertilization has been assessed at first cleavage. It has been assumed that eggs which fail to divide are unfertilized; division into two reflects monospermy and division into three or more cells results from polyspermy. In the present experiments the eggs of the sea urchins *Echinus esculentus* and *Psammechinus miliaris* were fertilized for a set time under controlled conditions and left to develop in sea water for 10–15 min at 16° C. A sample of these eggs was fixed in acetic-alcohol (1:1) for 24 hr and stained in acetic-orcein (0.5% in 50% acetic acid) for 24–48 hr. After staining, the developing male pronuclei were very conspicuous and could be counted by phase and light microscopy. Because some pronuclei might be unstained or indistinguishable from surface sperm, this count gives the minimum number of sperm in any given egg. In practice, the errors in making a sperm count were probably rather small because, where comparison was possible (for instance, at low sperm densities), the results of a sperm count agreed well with those obtained at first cleavage. At high sperm densities (10^8 /ml.) the agreement was often poorer because polyspermic eggs containing three or more sperm frequently failed to divide.

Some of the main results obtained by this method are summarized below:

(1) Fertilization with high sperm densities (10^7 to 10^8 sperm/ml.) produced many polyspermic eggs; but after the first sperm had interacted with the egg the rate of subsequent sperm uptake was much reduced. These results confirm those of Rothschild & Swann (1952).

(2) Pretreatment with nicotine (0.005–1% in sea water) increased the number of sperm entering an egg greatly: up to 100 sperm were counted

in some eggs (Fig. 1a). This uptake was complete within 20 sec. Even when applied after fertilization, nicotine still increased the uptake of sperm provided it was added before elevation of the fertilization membrane (Fig. 1b). The effects of nicotine pretreatment were reversed by prolonged washing in sea water.

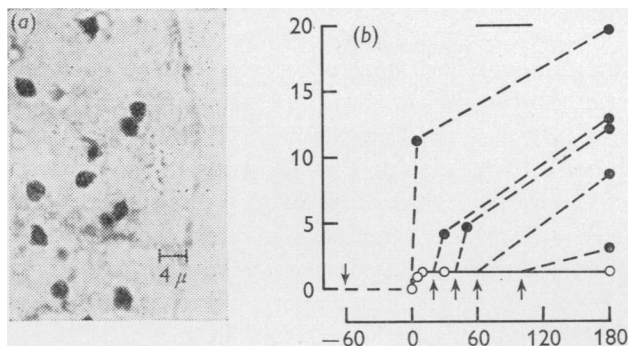

Fig. 1. The effect of nicotine on the uptake of sperm by the eggs of *E. esculentus*. Figure 1a is an optical section of part of an egg pretreated for 10 min in sea water containing 0.1% nicotine and fertilized for 5 sec with a sperm density of 10^8 /ml. Figure 1b shows the effects of nicotine treatment both before and after fertilization. Ordinate: average number of sperm/egg (20–30 eggs counted for each point); abscissa: time (sec). Fertilization was at zero time and employed 10^8 sperm/ml. The arrows mark the times at which nicotine was added to give a final concentration of 0.1%. Temp 17° C. O, control eggs; ●, eggs treated with nicotine. Fertilization membrane elevation was completed in most eggs during the period shown by the solid line.

(3) Okazaki (1956) reported that fertilization membrane elevation can be inhibited reversibly by metabolic poisons. This observation has been confirmed for the eggs of *E. esculentus* where the onset of inhibition following addition of 2 mM-CN (pH 8) or 0.2 mM-DNP (pH 7) parallels closely a fall in energy-rich phosphate compounds within the eggs.

In a number of experiments, CN-poisoned eggs were fertilized, the sperm killed and the eggs transferred to CN-free sea water to develop. In no case did development occur. Sperm counts on these eggs often showed a mixed population: some eggs contained male pronuclei while others showed no evidence of sperm penetration. All these eggs still had many cortical granules. Some batches of eggs showed no evidence at all of sperm penetration. This did not result from an effect on the sperm because control eggs were fertilized normally in CN-sea water. The failure of sperm uptake into fully poisoned eggs was unaffected by nicotine.

Our thanks are due to the Director and staff of the Laboratory of the Marine Biological Association, Plymouth for much assistance and to the Lalor Foundation for a grant to R.P.

REFERENCES

- HAGSTRÖM, B. E. & HAGSTRÖM, B. (1954). *Expl Cell Res.* **6**, 479.
OKAZAKI, R. (1956). *Expl Cell Res.* **10**, 476.
ROTHSCHILD, LORD & SWANN, M. M. (1951). *J. exp. Biol.* **28**, 403.
ROTHSCHILD, LORD & SWANN, M. M. (1952). *J. exp. Biol.* **29**, 469.

A small heated respiratory valve

By E. N. HEY. *M.R.C. Research Group on Respiration and Energy Metabolism in the New-born, The London Hospital Medical College, London, E. 1*

The new-born baby is an obligate nose breather with a resting tidal volume of only 10–20 ml. This poses special problems in the design of a satisfactory low-resistance low-dead-space respiratory valve. It is because of this that the trunk plethysmograph has been so widely used for respiratory studies. Golinko & Rudolph (1961) were the first to provide a partial solution. By using two 4 mm nylon balls as inspiratory and expiratory gravity valves and a Y-shaped connexion for the nares they were able to construct a valve of plastic tubing and glass with a dead-space of only 0.8 ml. This valve has since been used by a number of paediatric research workers. Nelson, Prod'hom, Cherry, Lipsitz & Smith (1962) ingeniously increased the valve's versatility by attaching a miniature Rahn–Otis end-tidal sampler to it, while Bruck & Paa (1965) amongst others have modified the dimensions, replaced the nylon balls with rubber flap valves and achieved a decrease in the resistance to air flow.

Condensation of water is, however, a serious problem, particularly when ball valves are used: air-flow resistance increases and valve function becomes very unreliable. This has largely prevented the valve's use in animal experiments or for more than a few minutes at a time. The fault has been overcome in the present design by surrounding the valve with a small glass warm-water jacket 2 cm in diameter and 5 cm high through which the two glass nasal tubes pass (Fig. 1). Condensation is completely prevented by keeping the water jacket at 40° C. Assembly from the glass components, two rubber bungs and transparent Vinyl tubing remains simple. The water-jacket still allows valve movements to be clearly watched and also helps to keep the component parts firmly aligned. The dead space is 0.7 ml. Performance can be further improved by lightly grinding the glass seatings for the two accurately machined balls (tolerance ± 0.001 in.); no back-leak can then be detected with a sensitive pneumotachograph during normal use and never exceeds 0.4% of the total flow rate during steady-flow tests. A leak-free connexion into the nose is achieved with short-tapered interchangeable glass or plastic adaptors. Testing for external leaks is best accomplished by using a miniature Benedict–Roth rebreathing circuit and occasionally placing a test weight

on the spirometer. The resistance to air flow of the component parts of the illustrated valve made with $\frac{5}{32}$ in. (4 mm) nylon balls is shown in Fig. 2*a*, and the total resistance of the assembled valve to air flow both at a constant flow rate and during normal breathing is shown in Fig. 2*b*. The opening pressure of the ball valves is 0.3 cm H₂O. Substitution of a rubber

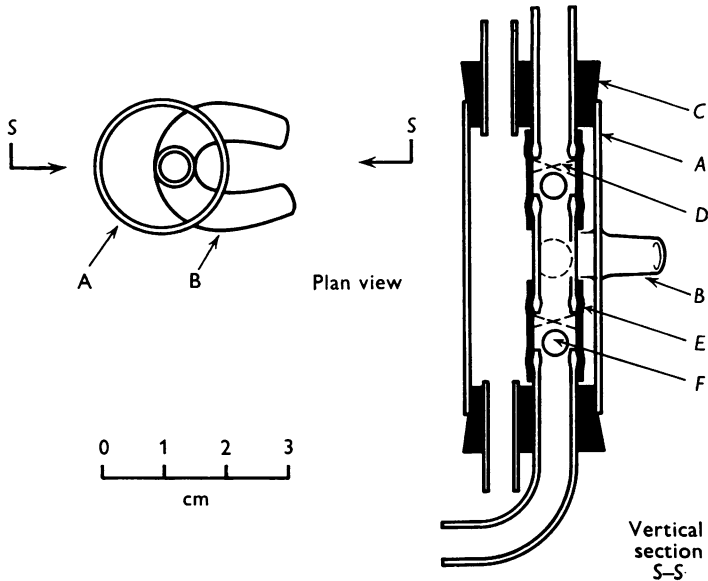

Fig. 1. Scale drawing of the water-jacketed nasal valve. *A*, water jacket; *B*, twin glass nasal tubes (interchangeable end adaptors not shown); *C*, rubber bung; *D*, nylon cross threads; *E*, transparent Vinyl tubing; *F*, $\frac{5}{32}$ in. nylon ball.

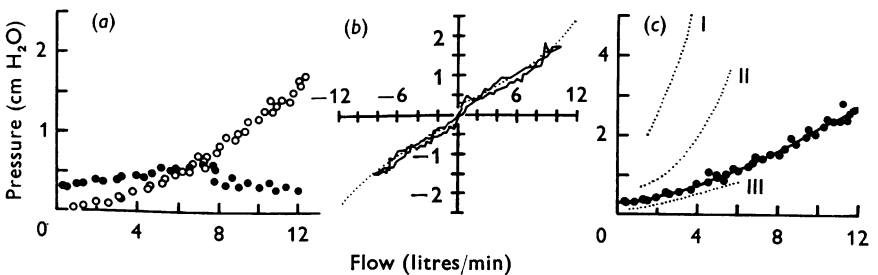

Fig. 2. (*a*) Resistance of the components of the valve in Fig. 1 to steady expiratory air flow: assembled tubing without ball valve, \circ ; additional resistance due to the ball valve (showing the fall that occurs when the ball rises clear of the seating) \bullet .

(*b*) Total inspiratory and expiratory resistance of the same valve to steady air flow, . . . , and to normal breathing in a 1-year-old child, —.

(*c*) Total expiratory resistance of the same valve with 40 cm of 7 mm I.D. tubing and an expiratory gas collecting bag (\bullet), and the comparable flow-resistance curves published by Golinko & Rudolph (I), Nelson *et al.* (II) and Silverman *et al.* (III).

flap valve not dependent on gravity slightly decreases flow resistance, but greatly increases the risk that significant back leak will occur; the use of $\frac{3}{16}$ in. (4.7 mm) ball valves and wider bore tubing decreases resistance more, while only increasing dead space 0.2 ml. The critical factor determining resistance is not the valve mechanism but the shape and internal diameter of the tubing and nosepiece. The improved resistance characteristics of the present illustrated valve are comparable with those achieved by Silverman, Sinclair & Buck (1966) with small flap-valved nose masks individually made and fitted to follow the contour of each baby's face (Fig. 2c).

REFERENCES

- BRUCK, E. & PAA, D. (1965). *J. Pediat.* **66**, 365–371.
 GOLINKO, R. J. & RUDOLPH, A. M. (1961). *Pediatrics, Springfield* **27**, 645–647.
 NELSON, N. M., PROD'HOM, L. S., CHERRY, R. B., LIPSITZ, P. J. & SMITH, C. A. (1962). *Pediatrics, Springfield* **30**, 963–974.
 SILVERMAN, W. A., SINCLAIR, J. C. & BUCK, J. B. (1966). *J. Pediat.* **68**, 468–470.

Voltage clamp experiments in skeletal muscle fibres

By R. H. ADRIAN, W. K. CHANDLER and A. L. HODGKIN. *Physiological Laboratory, University of Cambridge*

Figure 1 illustrates the principle of the method. Three micro-electrodes were inserted close to the pelvic end of a fibre in the frog's sartorius muscle. The current through electrode 3 was controlled by feed-back to

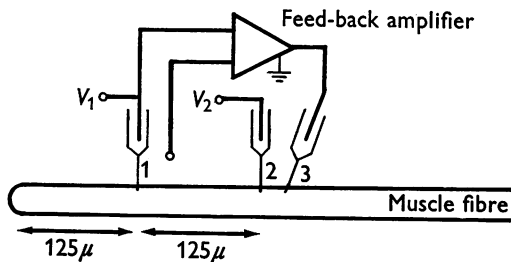

Fig. 1. Arrangement of micro-electrodes (cf. Adrian & Freygang, 1962); electrode 3 was screened; the voltage gain of the feed-back amplifier was 2000–10,000 and the electrode resistance were between 5 and 10 M Ω .

give a voltage step at electrode 1. The membrane current per unit length, i_m , was obtained from the voltage difference between electrodes 2 and 1 by the approximation $i_m \doteq 2(V_2 - V_1)/3l^2r_i$, where r_i is the internal resistance per unit length and l is the distance of electrode 1 from the end of the fibre (electrode 2 is at $2l$). For a linear cable the error in the approximation is less than 5% if $l/\lambda < 2$.

The method was used to study delayed currents in muscles treated with tetrodotoxin, to eliminate sodium currents, and hypertonic solutions, to eliminate or reduce contraction. Records *A-E* in Fig. 2 show that the outward current developed with an initial S-shaped delay; record *F*, on a slower time scale, shows that the delayed current was inactivated with a time constant of *ca.* 2 sec at 2° C (cf. Nakajima, Iwasaki & Obata, 1962).

The equilibrium potential for the delayed current varied with potassium concentration in the same way as that of an electrode with a K:Na selectivity of about 30. With 2.5 mM-K in the external solution this equilibrium potential was less negative than the resting potential and was approximately equal to the potential at the beginning of the after-potential.

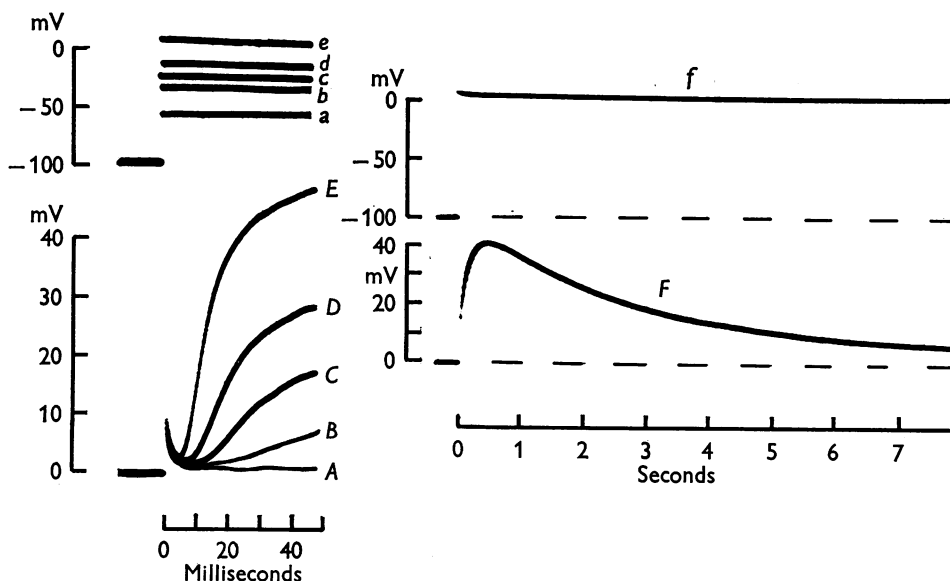

Fig. 2. *a-f*, membrane potentials (V_1) and *A-F*, membrane currents (V_2-V_1) in frog sartorius fibres at 2° C in Ringer + 350 mM-sucrose + 10^{-6} g/ml. tetrodotoxin; fibre diameters, 50 μ (*A-E*) and 55 μ (*F*); peak current density in *F* \doteq 1 mA/cm²; *A* and *B* were scaled from records at higher gain.

REFERENCES

- ADRIAN, R. H. & FREYGANG, W. H. (1962). *J. Physiol.* **163**, 104-114.
 NAKAJIMA, S., IWASAKI, S. & OBATA, K. (1962). *J. gen. Physiol.* **46**, 97-115.

The cephalic organ of the nemertine worm, *Linens ruber*

By E. N. WILLMER. *Physiological Laboratory, Cambridge*

The simultaneous demonstration of catecholamines and cholinesterases with the electron microscope

By P. R. LEWIS and C. C. D. SHUTE. *Department of Anatomy, University of Cambridge*

Glutaraldehyde fixation makes the noradrenaline containing granules of the adrenal medulla intensely osmiophilic; the adrenaline containing granules are also preserved but show only faint staining with osmium tetroxide. This differential staining is still retained even after tissues have been subjected to the thiocholine technique for cholinesterase previously demonstrated to the Society (Lewis & Shute, 1964). We have therefore used our technique, only slightly modified, to study the rat adrenal medulla.

True cholinesterase activity was demonstrated with acetylthiocholine as substrate in the presence of 10^{-4} M ethopropazine as an inhibitor of pseudocholinesterase. The scattered groups of ganglion cells were intensely stained. Staining in these cells was largely confined to the rough endoplasmic reticulum (Fig. 1*a*) and had a distribution strongly reminiscent of that seen in known cholinergic cells in the central nervous system (Lewis & Shute, 1966). Occasional myelinated fibres were seen, always with the whole of the axonal membrane intensely stained. There were scattered groups of unmyelinated axons containing neurotubules and contained within Schwann cells; again the axonal membranes were intensely stained. There were many heavily stained axonal processes, packed with microvesicles and without Schwann cells, directly apposed to chromaffin cells; occasionally there was some evidence of a subsynaptic apparatus (Fig. 1*b*). There was no clear indication of any difference of form or frequency in these endings on the two types of chromaffin cell. Only occasionally was there any staining for true cholinesterase within the chromaffin cells, and then it was usually restricted to small areas of the nuclear envelope—a distribution similar to that seen in other cholinceptive, non-cholinergic cells (Shute & Lewis, 1966).

To study the distribution of pseudocholinesterase, butyrylthiocholine was used as substrate without any inhibitor. No intensely stained ganglion cells were seen. The myelinated axons were virtually unstained. There was some staining associated with the groups of unmyelinated fibres, but it was usually in the mesaxons—as if the enzyme were on the membrane of the investing Schwann cell rather than on that of the neurones. The axonal processes apposed to the chromaffin cells were unstained and a subsynaptic apparatus could often be clearly seen. Most of the chromaffin cells showed moderate staining of the nuclear envelope together with scattered areas of staining in the rough endoplasmic reticulum—a few adrenaline-containing cells exhibited strong staining throughout the

nuclear envelope and the reticulum. Many of the endothelial cells also showed some staining.

Thus, apart from the endothelial and Schwann cells, pseudocholinesterase is confined to the chromaffin cells and is virtually absent from the presynaptic elements within the adrenal medulla. True cholinesterase, on the other hand, is associated with all the identifiable elements of the preganglionic sympathetic innervation—and also with the scattered

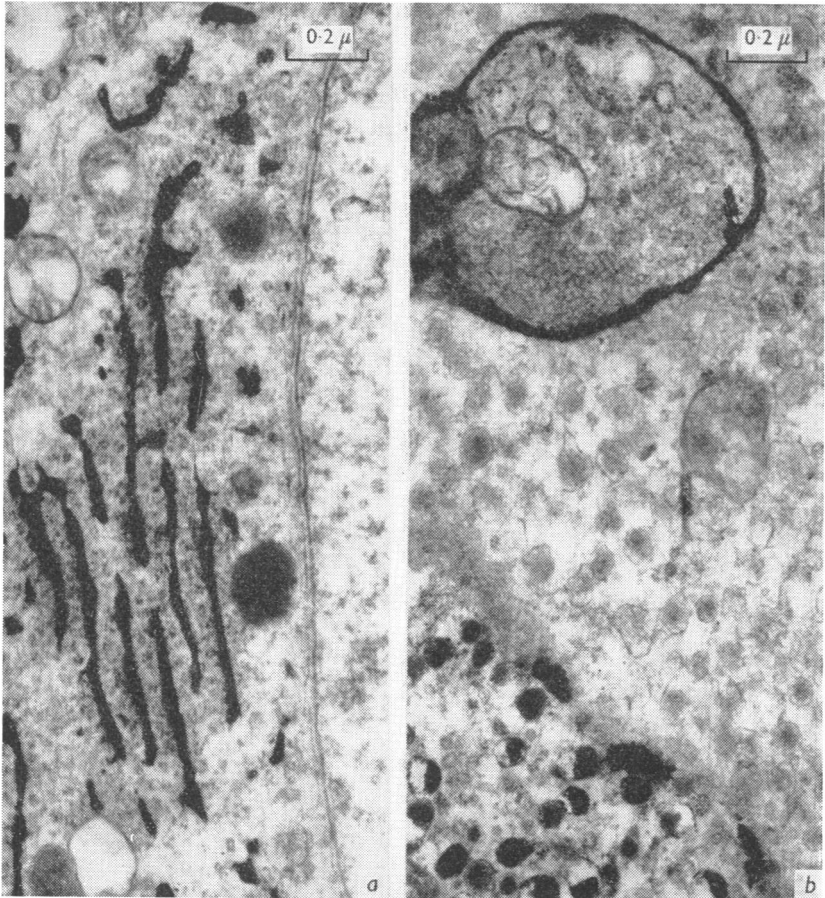

Fig. 1. Electron micrographs of rat adrenal medulla stained to show the distribution of true cholinesterase; sections counterstained with lead citrate—photographed at an initial magnification of 8000. (a) From a ganglion cell showing the intense staining of the rough endoplasmic reticulum (nuclear membrane on right-hand side of photograph). (b) A synaptic process, packed with microvesicles and with its membrane intensely stained by the enzyme technique, projecting into an adrenaline-containing cell (an adjacent noradrenaline-containing cell at the bottom left can be identified by its strongly osmiophilic granules).

ganglion cells which are almost certainly cholinergic but whose function is uncertain. The junctional region between axon and chromaffin cell is similar in morphology and enzyme distribution to cholinergic synapses that have been seen in the central nervous system.

REFERENCES

- LEWIS, P. R. & SHUTE, C. C. D. (1964). *J. Physiol.* **175**, 5P.
LEWIS, P. R. & SHUTE, C. C. D. (1966). *J. Cell Sci.* (In the Press.)
SHUTE, C. C. D. & LEWIS, P. R. (1966). *Z. Zellforsch.* **69**, 334.

Measurement of ^{24}Na and ^{42}K with a liquid-scintillation counting system without added scintillator

By P. J. GARRAHAN and I. M. GLYNN. *Physiological Laboratory, University of Cambridge*

Few laboratories can afford both a liquid-scintillation counting system and a well-type scintillator fitted with automatic sample changing equipment. Isotopes like ^{24}Na and ^{42}K , which are usually counted with a well-type counter, can be counted with higher efficiency using a liquid scintillator but the method has a number of disadvantages:

- (i) The addition of liquid scintillator is troublesome and expensive.
- (ii) Even with dioxane-naphthalene solvents it is not possible to count more than about 3 ml. of aqueous solution.
- (iii) Because of the short half-life it is necessary to calculate the time at which each sample was counted.
- (iv) The samples must be clear and more or less colourless to avoid quenching.

The first two disadvantages may be avoided by omitting the liquid scintillator. With ^{24}Na the relatively hard radiation (γ : 1.37 and 2.75 MeV; β : 1.39 MeV) appears to excite the glass of the vial or the quartz face of the photomultiplier tubes, or gives rise to Čerenkov radiation, sufficiently to be counted with an efficiency of about 26% (assuming 100% efficiency when liquid scintillator is present). This is less than the efficiency obtained with a conventional NaI crystal counter (about 40%), but the background is lower and the maximum volume of fluid that can be counted is greater. ^{42}K (γ : weak 0.32 MeV and 18% 1.52 MeV. β : 18% 2.0 MeV and 82% 3.6 MeV) without liquid scintillator is counted with an efficiency of about 62% (assuming 100% efficiency when liquid scintillator is present), compared with an efficiency of about 22% with a NaI crystal. The high efficiency obtained with ^{42}K is probably accounted for by Čerenkov radiation produced by the very hard β particles (see Belcher, 1953).

With a Nuclear Chicago '720' System, calculation of clock time can be avoided by a simple modification designed by Mr R. A. Baker of Conti-

mental Distributors Ltd., London. The third channel of the 'Auto Subtract' unit is used to provide pulses at 100/sec and these pulses are counted continuously on Scaler C and printed out in the usual way. Two switches restore Scaler C and the third channel of the 'Auto Subtract' unit to their normal operation when clock time is no longer required.

With any counter fitted with automatic sample changing, it is necessary to consider possible interference by samples waiting to be counted or samples that have already been counted. A vial of ^{42}K giving 10^6 dis/min placed in the most dangerous position, adjacent to the vial being counted, did not cause a significant increase in background. A vial of ^{24}Na giving 10^6 dis/min increased the background by less than 100 counts/min. With very little care it is therefore easy to avoid interference between samples.

If much of the scintillation comes from the glass wall of the vial, variation between vials could affect the counting rate. Standard vials designed for use with scintillation counting systems seem to vary in weight by not more than about 7% and within this range no effect on counting rate was observed.

We thank the Medical Research Council for a grant for the counter, and the Consejo Nacional de Investigaciones Científicas y Técnicas, Argentina, for a personal grant to one of us (P. J. G.).

REFERENCE

BELCHER, E. H. (1953). *Proc. R. Soc. A* **216**, 90-102.

Vascular supply to the absorptive surfaces of the ruminant stomach

By S. E. CHEETHAM and D. H. STEVEN. *Department of Anatomy and Sub-department of Veterinary Anatomy, University of Cambridge*

Three compartments of the ruminant stomach, rumen, reticulum and omasum, are lined by a keratinized non-glandular stratified epithelium, while the fourth, the abomasum, is comparable to the glandular stomach of other mammals. Volatile fatty acids produced by microbial fermentation are absorbed in large quantities through the keratinized epithelium of the first three compartments. The system of blood vessels underlying this epithelium is the subject of the present demonstration.

Welsh Mountain ewes were used for this study; they were anaesthetized with pentobarbitone sodium and given heparin (1000 i.u./kg). Arterial and venous injections of Chromopaque (Damancy & Co.) or neoprene latex (Revertex Ltd.) were given through cannulae in the coeliac artery and left ruminal vein. Both the Chromopaque and latex were diluted with equal parts of water, and the latter was coloured by an appropriate dye (Monolite fast red, 2RVS; Monastral fast blue, BVS: I.C.I.).

The most conspicuous feature of the blood supply to the wall of the

rumen is a complex system of anastomosing vessels which lies in the sub-epithelial connective tissue (Fig. 1). This subepithelial plexus is similar in appearance and position to the submucous plexus of the gut, and from it arterial and venous branches pass to the papillae and areas between them to form a dense capillary network lying in close apposition to the basal layer of the epithelium. From the main body of this network slender capillary loops, which are clearly visible in thick sections of injected

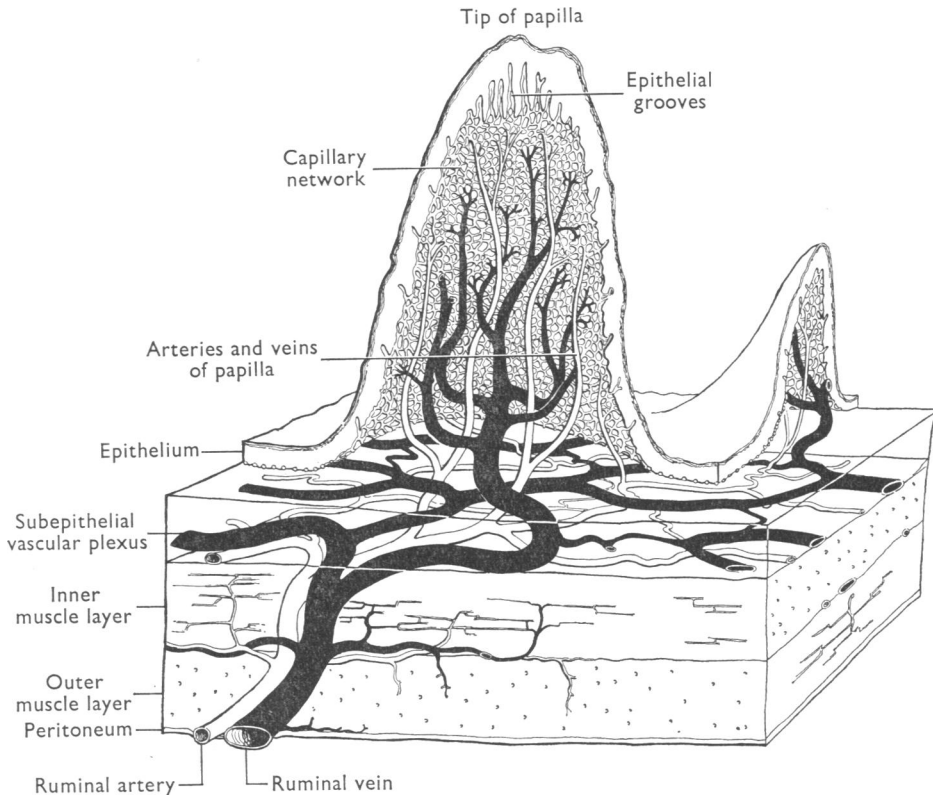

Fig. 1. Semi-diagrammatic drawing of the blood supply to the wall of the rumen (posterior dorsal blind sac).

material, enter and leave indentations of the basal layer (Fig. 2). It can be shown by microdissection and reconstruction of serial sections that these indentations, previously described as papillary bodies or processes (Dobson, Brown, Dobson & Phillipson, 1956; Fiebiger & Trautmann, 1957) form a system of interconnecting grooves in the deep surface of the epithelium. In the larger papillae the grooves may reduce the effective thickness of the epithelium by at least half, and expand the area of the vascular inner surface to almost twice that of the lumen side.

In the reticulum and omasum the pattern of epithelial vascularization is similar to that of the rumen. Sections of injected material from both these compartments show a well-developed subepithelial plexus and a dense capillary net, but the grooves in the basal layer of epithelium, which also contain capillary loops, are smaller and less conspicuous than those of the rumen.

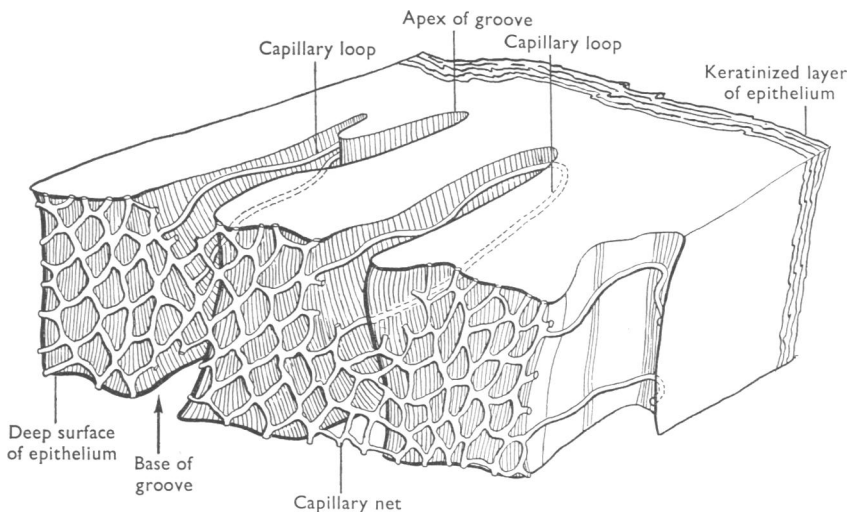

Fig. 2. Diagram to show the relationship between the capillary net and the deep surface of the rumen epithelium, based on papillae of the anterior dorsal sac.

REFERENCES

- DOBSON, M. J., BROWN, W. C. B., DOBSON, A. & PHILLIPSON, A. T. (1956). *Q. Jl exp. Physiol.* **41**, 247-253.
- FIEBIGER, J. & TRAUTMANN, A. (1957). *Fundamentals of the Histology of Domestic Animals*. Revised English edition. New York: Cornell University Press, Ithaca.

Properties of the motor cortex shown by stimulating it by means of implanted radio receivers

By G. S. BRINDLEY. *Physiological Laboratory, Cambridge*

Automatic syringes for repeated delivery of small volumes of fluid

By I. M. GLYNN and W. SMITH. *Physiological Laboratory, Cambridge*

A technique for making extremely small resistors

By G. S. BRINDLEY. *Physiological Laboratory, University of Cambridge*

It is useful in the construction of circuits for implantation into animals to have resistors smaller than any that are commercially available. These

can be made from a mixture of Simplex Rapid Acrylic (Dental Fillings Ltd., London, N. 16) and finely powdered charcoal. A convenient method of construction is illustrated in Fig. 1.

Rapid Acrylic powder is first mixed with charcoal in carefully weighed proportions. The dry mixture can be kept for many weeks. The wires are then bent to shape and fixed in the correct relation to one another. Rapid Acrylic liquid is added to the mixed powder to make a thin paste; the exact amount of liquid matters little. A drop of the freshly mixed paste is applied to the wires with a needle, preferably under a dissecting microscope. It sets completely in about 2 hr.

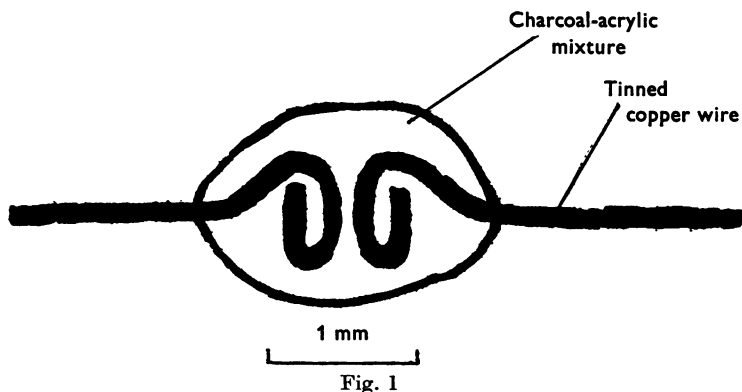

Fig. 1

The resistor shown in Fig. 1 has a resistance of about 1000 Ω if made with 3 parts by weight of Rapid Acrylic powder to 1 of charcoal, 10,000 Ω if made with 5 to 1, 100,000 Ω if made with 7 to 1. It obeys Ohm's law for power dissipations up to about 10 mW. Between 10 and 60 mW its resistance is reversibly lowered, and above about 60 mW irreversibly altered. It can be sterilized by boiling.

The recording of changes in the modulation pattern of high-frequency noise level from electrodes in the visual pathway during sleep

By A. R. GARDNER-MEDWIN. *Physiological Laboratory, Cambridge*

The spatial patterns seen when the retina is stimulated simultaneously with steady light and alternating electric current (Lohmann figures)

By G. S. BRINDLEY and J. G. WOLFF. *Physiological Laboratory, University of Cambridge*

The demonstration showed the effects on these patterns (Lohmann, 1940) of varying the brightness and colour of the light and the strength,

frequency and wave-form of the current. It also illustrates their relative constancy from one subject to another, which contrasts with the great variability of the patterns seen when, in the absence of electric currents, flickering light falls uniformly on the whole retina (Purkinje, 1823; Smythies, 1959).

REFERENCES

- LOHMANN, H. (1940). *Z. Sinnesphysiol.* **69**, 27.
 PURKINJE, J. (1823). *Beobachtungen und Versuche zur Physiologie der Sinne*, vol. 1. Prague: Calve.
 SMYTHIES, J. R. (1959). *Br. J. Physiol.* **50**, 106 and 305.

The action of muscarinic drugs on rubidium efflux from smooth muscle

By A. S. V. BURGEN and L. SPERO. *Department of Pharmacology, Cambridge*

The chorio-allantoic circulation in the chick embryo

By R. M. CLARKE. *Physiological Laboratory, Cambridge*

The pattern of villi in the duodenum of the chicken

R. M. CLARKE. *Physiological Laboratory, Cambridge*

Baker's dozen: thirteen physiological experiments from one electrophysiological unit

By P. E. K. DONALDSON. *Physiological Laboratory, Cambridge*

Changes in the intestinal epithelium of the new-born animal during the absorption of intact protein

By R. N. HARDY. *Physiological Laboratory, Cambridge*

The heat production of mammalian non-myelinated (C) nerve fibres

By J. V. HOWARTH, R. D. KEYNES and J. M. RITCHIE. *A.R.C. Institute of Animal Physiology, Babraham, Cambridge*

The thermal changes that accompany electrical activity in nerve fibres, though extremely small, are worth studying because they may give some insight into the processes that control the ionic fluxes that generate the action potential. Essentially, the equipment used in the present experiments incorporates a sensitive galvanometer (Kipp Stylo Model A 82

with half-strength magnet) with a photo-electric feed-back amplifier similar to that described in detail by Hill (1948), and a thermopile (Fig. 1A) with two elements T_1 and T_2 . Each element has an electrical resistance of 35 ohms and consists of a series of 100 palladium-gold/iron thermocouples whose 'hot' junctions lie on the mid line (under the nerves, Fig. 1A) and whose 'cold' junctions lie buried in a large mass of aluminium and epoxy resin at the sides of the pile. The speed of response of the system is such that a sudden warming of the preparation (by passing a brief high frequency current between its ends) causes a deflexion that reaches 50 and 90% of its maximum value in about 80 and 140 msec respectively, and declines from its maximum with a time constant of about 7 sec. Four electrodes (e_2, e_5, e_7 and e_{10}), joined in parallel, serve as stimulating cathodes, and another three (e_1, e_6 and e_{11}) as stimulating anodes. The remaining electrodes (e_3, e_4, e_8 , and e_9) are connected to earth to reduce spread of stimulating current over the face of the pile. The whole assembly is encased in an airtight, rigid chamber to prevent ambient pressure changes from causing adiabatic temperature changes in the region of the thermopile.

This equipment is being used to study the heat production of the C fibres of the rabbit vagus nerve, which are particularly suitable for thermal studies because of their small size. Four such nerves (about 80 mm long) are desheathed and mounted along the mid line on one face of the thermopile and another four in the corresponding position on the reverse face (Fig. 1A). A single impulse triggered by a stimulus 0.5 msec in duration produces an output from the thermopile that is not much larger than the random electrical noise (about 25×10^{-9} V); twenty or more single responses are therefore averaged electronically by a Mnemotron CAT computer. As in crab nerve (Abbot, Hill & Howarth, 1958), there is an evolution of about 5–10 $\mu\text{cal/g}$. shock, followed by a re-absorption of most of it; analysis suggests that these two phases correspond respectively with the depolarization and repolarization phases of the action potential (Howarth, Keynes & Ritchie, 1965). The initial positive and negative heats are succeeded by a prolonged phase of evolution of heat, the recovery heat.

The present thermopile is not ideal for studying recovery heat, because the relatively short time constant for diffusion of heat away from the nerve towards the sides of the pile means that a rather large integrating factor has to be applied to the experimental records to get absolute values for the heat. Nevertheless, it has been shown (thirteen experiments on six different sets of nerves) that a brief period of stimulation at a rate of 2.5 shocks/sec produced a recovery heat of 52.3 ± 6.7 (s.e.) $\mu\text{cal/g}$ shock, which was complete within 4.5 ± 0.5 min. Nine experiments carried

out between 5 and 25° C gave a Q_{10} of 2.07 ± 0.42 . The recovery heat was always much reduced, and often abolished, by ouabain ($140 \mu\text{M}$), and also when the sodium of Locke's solution was completely replaced by lithium (Fig. 1B). On the other hand, it was slightly *increased* (by about 14%) in potassium-free solutions (Fig. 1B).

This work was partly supported by a grant NBO 1927 from the U.S.P.H.S.

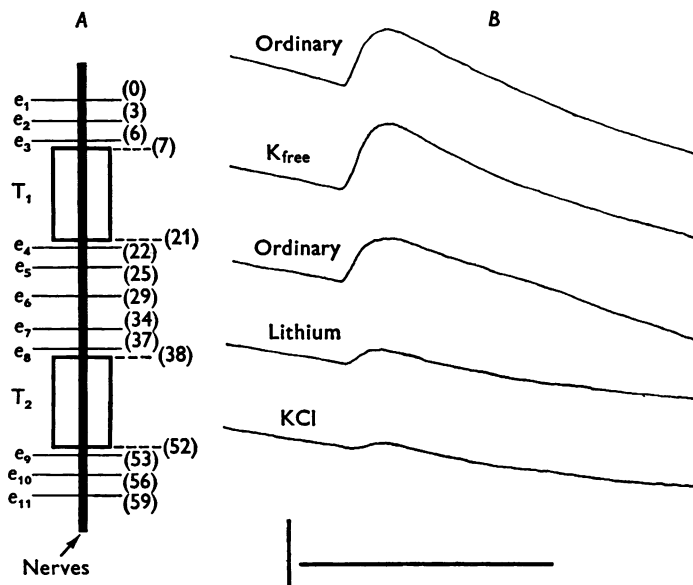

Fig. 1. A, Diagram of thermopile. The numbers in parentheses indicate the distance in mm from e_1 . B, Recovery heat in rabbit desheathed vagus nerve at 20.8° C after 20 shocks at 2.5/sec in ordinary, in K-free, and in lithium, Locke's solution. A record showing complete recovery when the lithium was replaced again by sodium has been omitted. The bottom record, taken after the preparation had been soaked in isotonic KCl, shows the heating effect of the stimulus. The vertical bar represents a temperature change of $20 \mu^\circ\text{C}$ and the horizontal bar 100 sec.

REFERENCES

- ABBOTT, B. C., HILL, A. V. & HOWARTH, J. V. (1958). *Proc. R. Soc. B*, **148**, 149-187.
 HILL, A. V. (1948). *J. scient. Inst.* **25**, 225-229.
 HOWARTH, J. V., KEYNES, R. D. & RITCHIE, J. M. (1965). *J. Physiol.* **181**, 40-42P.

Metabolism of labelled progesterone by goat mammary tissue *in vivo* and *in vitro*

By R. B. HEAP and J. L. LINZELL. *Institute of Animal Physiology, Babraham, Cambridge*

Steroids secreted by the pig adrenal *in vivo*

By R. B. HEAP, MARGARETHE HOLZBAUER-SHARMAN and HELEN NEWPORT. *Institute of Animal Physiology, Babraham, Cambridge*

The effect of eliminating fluctuations of gas tensions in arterial blood on carotid chemoreceptor activity and respiration

By M. J. PURVES. *Department of Experimental Medicine, University of Cambridge, and Institute of Animal Physiology, Babraham*

Fluctuations of oxygen tension in arterial blood (P_{a, O_2}) which have the same period as respiration have been demonstrated in the anaesthetized cat (Purves, 1964). The question arises as to whether these fluctuations merely follow corresponding changes in alveolar gas tensions within each respiratory cycle or whether they are made use of in the regulation of respiration.

A method which has been devised to answer this question, in part, has been to insert a rigid polyethylene mixing chamber of 7 ml. dead space into each carotid artery of the lightly anaesthetized cat. The vertebral arteries were clamped. Blood could then be made to flow directly through the carotid loops or diverted with the same flow rate and mean oxygen tension through the mixing chambers. Carotid chemoreceptor activity was measured in single or few fibre preparations in one of the sinus nerves during artificial positive pressure ventilation. Changes in tidal volume and respiratory frequency were monitored when the animals were breathing spontaneously.

Chemoreceptor activity was measured in seven cats with the rate and depth of ventilation set so that fluctuations of P_{a, O_2} varied between ± 0.75 and ± 4.2 mm Hg. When these fluctuations were eliminated in the mixing chambers, chemoreceptor activity lost its fluctuating rhythm (Biscoe & Purves, 1965) and, invariably, the mean frequency of discharge fell by 4–17% of control. The amount by which mean chemoreceptor frequency fell was directly related to the amplitude of the fluctuations in the control period.

Changes in spontaneous breathing were more variable. On eighteen out of the thirty-seven occasions in which the normal flow path was diverted to the mixing chamber tidal volume fell by between 5 and 14% of control. There was no change in respiratory frequency. On twelve occasions, respiration became irregular both in rate and volume, and on seven occasions true periodic respiration with a period of 25–35 sec developed. All these changes were reversed when normal carotid flow was re-established.

REFERENCES

- BISCOE, T. J. & PURVES, M. J. (1965). *J. Physiol.* **177**, 72–73 P.
PURVES, M. J. (1964). *J. Physiol.* **176**, 7–8 P.

The measurement of content of oxygen, carbon dioxide, nitrous oxide and carbon monoxide in gas mixtures and in blood using gas chromatography

By M. J. PURVES. *Institute of Animal Physiology, Babraham, Cambridge*

Penetration of a monomolecular film of phosphatides by hyperbaric inert gases

By A. D. BANGHAM, P. BENNETT and D. PAPAHDJOPOULOS. *Institute of Animal Physiology, Babraham, Cambridge*

Collection of lymph from unanaesthetized sheep under physiological conditions

By J. G. HALL. *Institute of Animal Physiology, Babraham, Cambridge*

The engulfment and metabolism of bacteria by the rumen ciliate *Entodinium caudatum*

By G. S. COLEMAN. *Institute of Animal Physiology, Babraham, Cambridge*

Quantitative studies on nitrogen metabolism in the rumen

By J. L. MANGAN. *Institute of Animal Physiology, Babraham, Cambridge*

The yield of synaptosomes from cerebral cortical tissue: comparisons with histological estimates of the number of nerve endings in whole tissue

By F. CLEMENTI and V. P. WHITTAKER. *Institute of Animal Physiology, Babraham, Cambridge*

The osmotically sensitive volume of synaptosome preparations

By R. M. MARCHBANKS. *Institute of Animal Physiology, Babraham, Cambridge*

An electron microscopic study of the interaction of macroglobulin (IgM) antibodies with bacterial flagella and of the binding of complement

By A. FEINSTEIN and E. A. MUNN. *Institute of Animal Physiology, Babraham, Cambridge*

The complexes formed by *Salmonella paratyphi* flagella with bovine and human anti-flagella IgM (and the interaction of the latter with guinea-pig

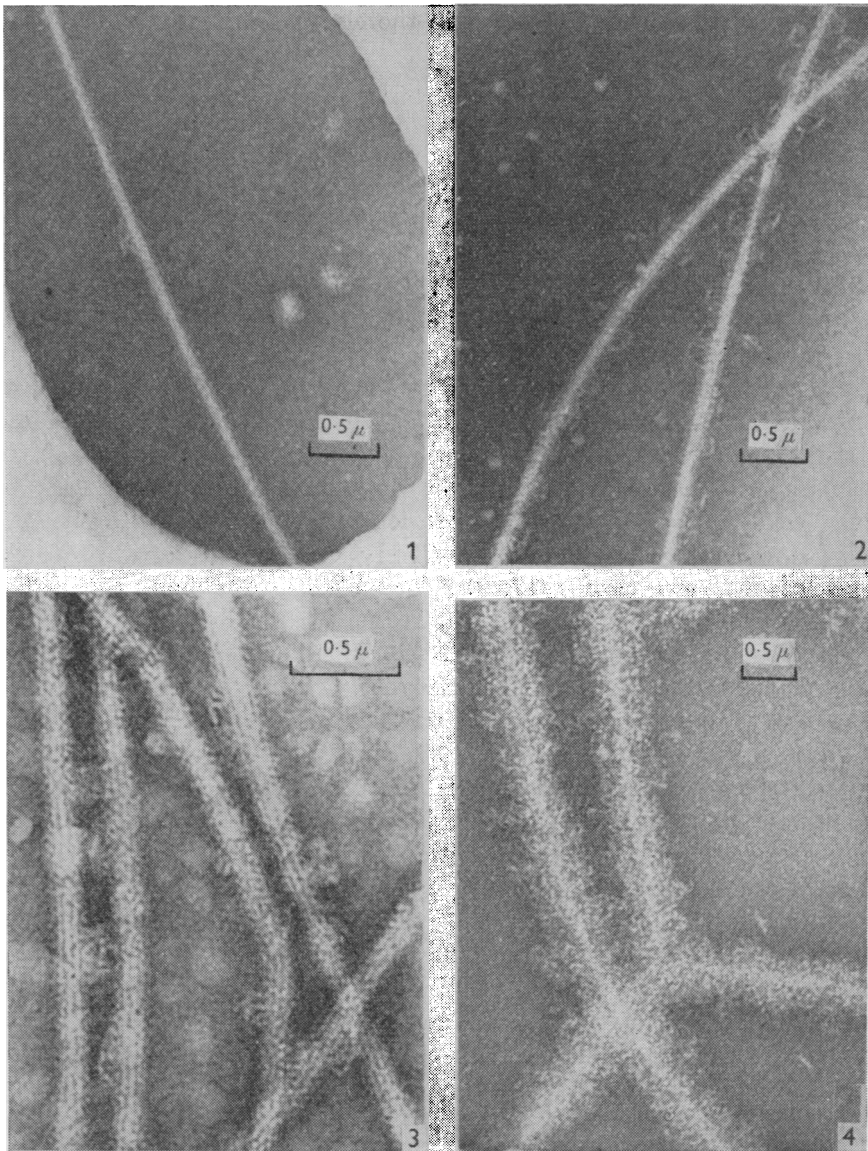

Fig. 1. Electron micrograph of part of a flagellum from a preparation agglutinated in the lowest effective concentration of bovine antibody. Negatively stained with sodium phosphotungstate pH 7.

Fig. 2. Flagella from a preparation agglutinated in an antibody concentration $8\times$ the end-point concentration of bovine antibody. Negatively stained with sodium phosphotungstate pH 7.

Fig. 3. Flagella from a preparation agglutinated in an antibody concentration $8\times$ the end-point concentration of bovine antibody. Negatively stained with uranyl acetate pH 4.2.

Fig. 4. Flagella from a preparation agglutinated in $4-8\times$ end-point concentration of human antibody and then incubated with guinea-pig serum. Negatively stained with sodium phosphotungstate pH 7.

complement) have been examined in the electron microscope by means of the negative-staining technique.

Bovine antiserum to isolated flagella and human antiserum to whole organisms were fractionated by gel filtration on Sephadex G-200, and agglutinating activity was present only in the IgM fraction. Complement activity in the antisera was destroyed by heating at 56° C for 30 min. Suspensions of formalin-killed bacteria (Burroughs Wellcome) were agglutinated in a series of dilutions of antibody and then washed twice with chilled saline and finally with distilled water. To study the binding of complement components some of the agglutinated suspensions obtained with human antiserum were subsequently incubated with dilutions of guinea-pig serum and then rewashed as above.

Fig. 1 shows the appearance of flagella in a preparation agglutinated in the lowest effective concentration of bovine antibody (end-point). In such preparations antibody molecules not linking flagella are rarely or never seen. When the bacterial suspension is agglutinated in higher antibody concentrations non-linking antibody molecules along the flagella are clearly visible in profile (Fig. 2). The molecules are highly penetrated by negative stain (in contrast to the free macroglobulin) and are seen as staple-like structures formed of rods 20–25 Å in diameter, with a maximum dimension of 140 Å which is considerably less than the observed maximum dimension of free IgM molecules. Antibodies cross-linking parallel flagella are also seen to be formed of rods 25 Å in diameter, but the molecules are more extended than in the 'staple' form (Fig. 3). Similar results to the above were obtained using human IgM to agglutinate the flagella. When these complexes were incubated with guinea-pig serum there was a remarkable alteration in appearance (Fig. 4). Bound complement appeared at first as patches along the flagella. Where more complement was bound the patches fused into a continuous sheath. Identical results were obtained using agglutinated preparations of isolated flagella. Preparations which had not been agglutinated with antibody, and agglutinated flagella which were incubated with guinea-pig serum previously heated to inactivate the complement, did not give this appearance.

The electron micrographs show that IgM undergoes a shape change on forming a complex with the antigen and we suggest that this is important for the subsequent activation of complement.

The adsorption of calcium on unimolecular films of phospholipids

By R. M. C. DAWSON and H. HAUSER. *Institute of Animal Physiology, Babraham, Cambridge*

The rates of disappearance of L-lactate dehydrogenase isoenzyme activities from plasma

By J. W. BOYD. *Biochemistry Department Institute of Animal Physiology, Babraham, Cambridge*

Five isoenzymes of L-lactate dehydrogenase (L-lactate:NAD oxidoreductase, EC 1.1.1.27) can be separated by electrophoresis. These isoenzymes are tetramers composed of different proportions of two monomers. Cahn, Kaplan, Levine & Zwilling (1962) called the monomers H and M,

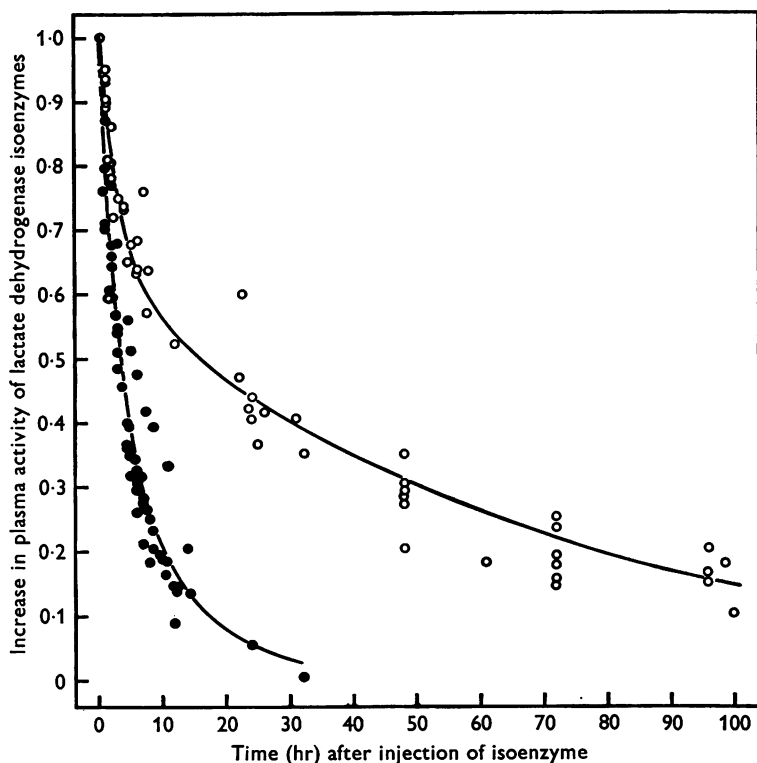

Fig. 1. Intravenous injection of purified sheep lactate dehydrogenase isoenzymes into lambs. O, Isoenzyme H_4 and ●, isoenzyme M_4 as fractions of the increased activities shortly after injection. Double exponential curves fitted to pooled data from six experiments with each isoenzyme.

and the tetramers H_4 , H_3M_1 , H_2M_2 , H_1M_3 and M_4 . Although M-type isoenzymes predominate in skeletal muscle, Boyd (1964) found that the increases in plasma activities of these isoenzymes were unexpectedly small in lambs with muscular dystrophy induced by vitamin E deficiency.

Further experiments have shown that vitamin E therapy produces prompt clinical recovery and the elevated plasma isoenzyme activities

return to normal presumably because abnormal enzyme leakage from muscle is stopped.

However, the activities of the different isoenzymes fall exponentially at different rates. The half-lives of isoenzymes H_4 , H_3M_1 , H_2M_2 , H_1M_4 and M_4 were 48, 31, 20, 13 and 7 hr respectively. Moreover, following i.v. injection into normal animals, the plasma disappearance rate of purified isoenzyme M_4 was much faster than that of isoenzyme H_4 (Fig. 1). The disappearance of isoenzyme M_4 activity occurred in two phases with half-lives of 2.0 and 8.0 hr. The comparable values for isoenzyme H_4 were 2.4 and 48.0 hr. Thus the relatively low plasma activities of the M-type isoenzymes in muscular dystrophy are at least partly due to their more rapid plasma disappearance rates.

REFERENCES

- BOYD, J. W. (1964). *Res. Vet. Sci.* 5, 419.
CAHN, R. D., KAPLAN, N. O., LEVINE, L. & ZWILLING, E. (1962). *Science, N.Y.* 136, 962.

The assembly of tropocollagen macromolecules to form native collagen fibrils

By R. W. COX, R. A. GRANT and R. W. HORNE. *Institute of Animal Physiology, Babraham, Cambridge*

Cross-linking of collagen with glutaraldehyde increases the total light area as visualized with negative staining techniques and high resolution electron microscopy. With native collagen of 640 Å period the A band is increased from its normal width of approximately 280 Å to a width of approximately 340 Å and a further prominent white band occurs in the B band. From experiments such as these and from using a number of different cross-linking agents it has been suggested that the white bands seen in negatively stained preparations are an expression of lateral intermolecular bonding.

Negative staining methods have also suggested a division of the tropocollagen macromolecule (approximately 2800 Å long) into five main bonding zones (each approximately 280 Å long) and four intervening, main non-bonding zones (each approximately 360 Å long). It is postulated that native collagen fibrils with a 640 Å periodicity are formed from such macromolecules by a repeated process, which allows any main bonding zone on one macromolecule an initial random choice in laterally bonding with any main bonding zone on another macromolecule. The lateral intermolecular bonding is believed to occur by virtue of structural complementarity. This type of assembly abolishes the need for long, linear protofibrils of the type envisaged by Hodge, Petruska & Bailey (1965) in their 'quarter-stagger' method of packing.

It also follows from the present assembly that the ratio of the number of macromolecules occurring in the B band of a native fibril to the number of macromolecules in the A band is 4:5 or 0.80. Experimental testing of this prediction, using microdensitometer counts across the A and B bands, gives a mean value for the ratio of 0.73 and a standard deviation of 0.10.

Further evidence for the division of the tropocollagen macromolecule into five main bonding zones and four main non-bonding zones is provided by experiments with the fibrous long spacing form of collagen (FLS) which has a periodicity of approximately 2300 Å. When FLS is cross-linked with glutaraldehyde a native type of periodicity appears. This is interpreted as meaning that in FLS the macromolecules, which are in antiparallel array, are laterally linked by the terminal, main bonding zones only and that the ability of the three intermediate, main bonding zones to bond laterally is suppressed by the glycoprotein used in preparing the FLS. Glutaraldehyde, however, can establish cross-links between these zones in spite of the glycoprotein and so a native type of periodicity appears.

REFERENCE

HODGE, A. J., PETRUSKA, J. A. & BAILEY, A. J. (1965). In *Structure and Function of Connective and Skeletal Tissue*, p. 31. London: Butterworth.

The turnover of 3,4-dihydroxyphenylethylamine (dopamine) in the brain

By D. F. SHARMAN. *Institute of Animal Physiology, Babraham, Cambridge*

4-Hydroxy-3-methoxyphenylacetic acid (homovanillic acid), an acid metabolite of dopamine, is present in the mammalian brain (Sharman, 1963; Andén, Roos & Werdinius, 1963). Laverty & Sharman (1965) considered that an increase in the turnover of dopamine could have taken place when the concentration of this acid metabolite was increased. However, the possibility of a restriction of the outflow of the acid from the brain must be taken into account.

Spector, Sjoerdsma & Udenfriend (1965) have suggested that the rate of fall of the concentration of dopamine in a tissue after blockade of the synthetic pathway of this amine might be used to determine the rate of turnover. By combining such a blockade with observations on the effects of drugs on the concentration of homovanillic acid in the striatum of the mouse, it has been possible to distinguish different mechanisms by which the concentration of homovanillic acid in the tissue can be increased.

REFERENCES

- ANDÉN, N.-E., ROOS, B.-E. & WERDINIUS, B. (1963). *Life Sci. Oxford*, No. 7, pp. 448-458.
LAVERTY, R. & SHARMAN, D. F. (1965). *Br. J. Pharmac. Chemother.* **24**, 759-772.
SHARMAN, D. F. (1963). *Br. J. Pharmac. Chemother.* **20**, 204-213.
SPECTOR, S., SJOERDSMA, A. & UDENFRIEND, S. (1965). *J. Pharmac. exp. Ther.* **147**, 86-95.

Wheel running in mice as a measure of voluntary activity

By ELIZABETH SHILLITO. *Institute of Animal Physiology, Babraham, Cambridge*

The effect of drugs on monoamines and their metabolites in the brain of birds and mammals

By A. V. JUORIO. *Agricultural Research Council Institute of Animal Physiology, Babraham, Cambridge*

The administration of reserpine and prenylamine decreases the brain concentration of 5-hydroxytryptamine and all catecholamines in mammals and birds. The extent to which these effects occur are similar in pigeons, rabbits and cats, but in rats they are less conspicuous. In mammals the concentration of homovanillic acid, the main metabolite of dopamine, increases in the brain after administration of reserpine. After prenylamine, however, in spite of a substantial loss of dopamine, the concentration of homovanillic acid does not change. In the pigeon, these drugs do not produce any significant change in the concentration of homovanillic acid in the brain. This suggests that the metabolism of dopamine may follow different pathways, or that the rate of outflow of homovanillic acid is not the same in the brain of different animal species, or that any of these processes may be modified by drugs in a different way. In contrast, after the administration of prenylamine or reserpine the brain concentration of 5-hydroxyindolyl acetic acid is increased in all animal species so far examined.

β -Tetrahydronaphthylamine, a drug which produces central sympathetic stimulation, decreases the concentration of noradrenaline in the hypothalamus of mammals (Vogt, 1954), whereas the concentration of dopamine is not lowered and in mice may even be increased (Sharman, 1966). The concentration of homovanillic acid is increased in the brain of cats or mice but not in that of dogs. The concentration of 5-hydroxyindolyl acetic acid remains unchanged in cats and dogs (Lavery & Sharman, 1965) and is decreased in mice (Sharman, 1966). β -Tetrahydronaphthylamine decreases the concentration of noradrenaline, dopamine, homovanillic acid, 5-hydroxytryptamine and 5-hydroxyindolyl acetic acid in the pigeon. This general decrease of monoamines and metabolites suggests

TABLE 1. The effect of some drugs on the concentration of some brain monoamines and their metabolites in the pigeon, rat and rabbit. Mean tissue content, $\mu\text{g/g} \pm$ standard error of the mean, number of experiments are in parentheses; *i.m.*, *intramuscular*; *s.c.*, *subcutaneous*; *i.p.*, *intraperitoneal*

Reference	Drug	Dose (mg/kg)	Time (hr) and mode of injection	Noradrenaline hypothalamus	'Striatum'			Cerebral hemispheres or whole brain	
					Dopamine	Homovanillic acid	5-hydroxy-tryptamine	5-hydroxyindolyl acetic acid	
<i>Pigeon</i>									
	Controls	—	—	1.26 \pm 0.05 (21)	3.55 \pm 0.12 (39)	0.84 \pm 0.07 (25)	0.84 \pm 0.02 (26)	0.26 \pm 0.01 (25)	
	Reserpine	1	4, i.m.	0.56 \pm 0.15 (5)*	0.10 \pm 0.02 (8)*	0.60 \pm 0.13 (3)	0.31 \pm 0.06 (3)*	0.34 \pm 0.07 (3)*	
	Prenylamine	50	4, i.m.	0.73 \pm 0.15 (3)*	0.29 \pm 0.04 (4)*	0.49 \pm 0.07 (4)	0.38 \pm 0.06 (4)*	0.36 \pm 0.08 (4)*	
	β -tetra (<i>a</i>)	50	2, i.m.	0.95 \pm 0.07 (5)†	1.50 \pm 0.16 (14)*	0.40 \pm 0.07 (8)†	0.51 \pm 0.06 (6)*	0.09 \pm 0.02 (6)*	
		50	4, i.m.	0.79 \pm 0.09 (6)*	2.27 \pm 0.34 (7)*	0.22 \pm 0.06 (4)*	0.85 \pm 0.11 (3)	0.09 \pm 0.02 (6)*	
	M99 (<i>b</i>)	0.1	4, i.m.	1.24 \pm 0.15 (3)	—	—	0.77 \pm 0.02 (6)	0.23 \pm 0.03 (3)	
		0.4	1, i.m.	—	3.55 \pm 0.11 (6)	—	0.87 \pm 0.06 (3)	0.38 \pm 0.03 (3)†	
		0.8	4, i.m.	0.80 \pm 0.12 (5)*	—	—	0.77 \pm 0.11 (3)	0.26 \pm 0.03 (3)	
<i>Rat</i>									
1	Controls	—	—	—	—	—	0.40 \pm 0.02 (12)	0.45 \pm 0.02 (11)	
	Reserpine	1.25	4, i.p.	—	—	—	0.19 \pm 0.01 (10)*	0.84 \pm 0.09 (8)*	
2	Controls	—	—	—	3.0 \pm 0.3 (8)	0.20 \pm 0.05 (4)	—	—	
	Reserpine	2	4, s.c.	—	0.9 (1)	0.56 \pm 0.03 (4)†	—	—	
		5	4, i.p.	—	0.6 \pm 0.6 (2)	—	—	—	
3	Controls	—	—	3.61 \pm 0.18 (20)	1.16 \pm 0.06 (30)	—	0.58 \pm 0.03 (22)	0.42 \pm 0.02 (22)	
	Prenylamine	50	4, s.c.	2.75 \pm 0.32 (6)†	0.52 \pm 0.02 (7)*	—	—	—	
		100	3, s.c.	—	—	—	—	—	
	Controls	—	—	—	3.08 \pm 0.23 (5)	0.18 \pm 0.03 (4)	0.48 \pm 0.04 (8)	0.49 \pm 0.03 (7)†	
	β -tetra	30	2, s.c.	—	3.67 \pm 0.12 (4)	0.25 \pm 0.02 (4)	—	—	
<i>Rabbit</i>									
3	Controls	—	—	—	9.8; 10.8 (2)	5.2 \pm 0.4 (7)	—	—	
	Reserpine	2	4, s.c.	—	< 0.5 (4)	9.1 \pm 0.4 (4)*	—	—	
	Prenylamine	100	4, s.c.	—	1.4; 1.2 (2)	5.9 \pm 0.3 (5)	—	—	

(*a*) β -tetrahydronaphthylamine hydrochloride, (*b*) 6,14-endoetheno-7-(2-hydroxy-2-pentyl)-tetrahydro-oripavine hydrochloride.
 * $P < 0.001$; † $P < 0.01$; ‡ $P < 0.05$; § whole brain stem.
 1. Robinson, D. & Sharman, D. F. (1966, personal communication).
 2. Juorio, A. V., Sharman, D. F. & Trajkov, T. (1966).
 3. Juorio, A. V. & Vogt, M. (1965).

that in pigeons, β -tetrahydronaphthylamine might block an early step in the synthesis of all monoamines.

As morphine does in mammals, M 99 (6,14-endoetheno-7-(2-hydroxy-2-pentyl)-tetrahydrooripavine hydrochloride), a compound with morphine-like activity, reduces the concentration of noradrenaline in the hypothalamus of the pigeon, while dopamine and 5-hydroxytryptamine concentrations are not modified. M 99 increases the concentration of homovanillic acid in mice (Sharman, 1966) and that of 5-hydroxyindolyl acetic acid in the pigeon.

The author acknowledges with thanks support by the Wellcome Trust.

REFERENCES

- JUORIO, A. V., SHARMAN, D. F. & TRAJKOV, T. (1966). *Br. J. Pharmac. Chemother.* **26**, 385-392.
- JUORIO, A. V. & VOGT, M. (1965). *Br. J. Pharmac. Chemother.* **24**, 566-573.
- LAVERTY, R. & SHARMAN, D. F. (1965). *Br. J. Pharmac. Chemother.* **24**, 759-772.
- SHARMAN, D. F. (1966). *Br. J. Pharmac. Chemother.* (In the Press.)
- VOGT, M. (1954). *J. Physiol.* **123**, 451-481.

Effects of cooling the hypothalamus in the pig

By B. A. BALDWIN and D. L. INGRAM. *Institute of Animal Physiology, Babraham Hall, Babraham, Cambridge*

Pigs, placed in a cold environment, readily learned to press a panel switch mounted at the end of their cage, in order to obtain a short burst of infra-red heat. The infra-red heat was provided by 12 \times 250 W I.R. lamps suspended above the pig's cage and each burst of heat lasted 3 sec, the duration being controlled by a timing device. The pigs operated the panel switch with their snouts and each press on the panel (termed a response) made while the heaters were off resulted in a burst of heat (termed a reinforcement). Responses made while the heaters were on did not result in an extra reinforcement being delivered, nor did keeping the panel switch pressed down prolong the 3 sec heating period. All responses and reinforcements were recorded on counters. It has been shown that the rate at which pigs responded for infra-red heat declined markedly above 25° C ambient temperature.

The effect of cooling the hypothalamus on this operant behaviour has been investigated. A thermode, consisting of two stainless steel tubes ending in a small copper tank, was implanted aseptically under general anaesthesia into the pre-optic region of the brain with the tank lying in the mid line between the optic chiasma and the anterior commissure. The thermode was attached to the skull by means of dental cement and stainless steel screws. A thermistor was attached to the side of the copper

tank and the whole assembly coated with 'Araldite' to reduce tissue toxicity. Animals were ready to be tested about 10 days after the surgery. To cool the hypothalamus, cold alcohol was passed through the thermode by applying suction and the temperature registered by the thermistor reduced to 10° C. Under these conditions, it has been demonstrated that the temperature of the brain 5 mm. from the thermode was reduced 2-3° C.

Because tubes had to be attached to the thermode it was necessary to restrain the pig by means of a harness which could be attached to a strong metal stand. This stand allowed the pig to reach forward and operate the panel switch either from a standing or a sitting position. In this situation the infra-red lamps were suspended about 18 in. above the pig's back.

Cooling the hypothalamus for a 30 min. period always increased the response rate at low ambient temperatures, but at ambient temperatures of 30 or 35° C there was usually no effect. Cooling other regions of the brain by means of thermodes implanted outside the hypothalamic region had no effect on response rate.

This technique of cooling the hypothalamus has also been used to investigate the effect of lowering hypothalamic temperature on panting in a warm environment. Pigs, exposed to an ambient temperature of 40° C, experience a rise in body temperature and their respiratory rate rises to over 200/min. Cooling the hypothalamus, under these conditions, reduced respiratory frequency to about 20/min. When the hypothalamus was cooled continuously from the moment the pigs were placed in a hot environment, the onset of panting was prevented. Immediately the cooling ceased, however, the respiratory rate rapidly rose to over 200/min.

The thermodes were inserted using a stereotaxic instrument developed in this laboratory. In the absence of a stereotaxic brain atlas for the pig, the placements were made in relation to bony landmarks revealed by X-rays.

Factors influencing thermoregulation in mice

By B. A. BALDWIN. *Institute of Animal Physiology, Babraham, Cambridge*

A mouse placed in a cold environment will learn to depress a small lever in order to obtain a short burst of heat provided by an infra-red lamp suspended above the animal. Both normally haired mice and a special strain of hairless mice have been trained to make the above operant responses. Similar methods have previously been used to investigate behavioural thermoregulation in rats (Weiss & Laties, 1961). In the work being demonstrated the hairless strain of mice have been used.

During the experiments the mice are given trials lasting 1 hr each day

and the number of lever presses (termed a response) and bursts of heat received (termed a reinforcement) are recorded on counters. Only responses made during the period in which the infra-red lamp was off resulted in the lamp being switched on, responses made while the infra-red lamp was on did not result in any extra duration of heating, and holding the lever down continuously did not prolong the heating period unless the experimenter wished to reinforce this type of response. The effect of various factors on behavioural thermoregulation are outlined below.

(a) *Effect of intensity of infra-red radiation.* The ambient temperature was kept constant at $0^{\circ}\text{C} \pm 1.5^{\circ}\text{C}$ and the duration of each burst of heat maintained at 3 sec. A group of six hairless mice, previously trained to respond for heat, were exposed for a series of 1 hr trials at three different intensities of heating provided by infra-red bulbs of 150, 250 and 300 W. The different bulbs were presented each day in random order and each mouse received five trials at each wattage. It was demonstrated that the response rates of the mice and hence the number of reinforcements received were highest with the 150 W bulb and lowest with the 300 W bulb. The results obtained with the 250 W bulb were intermediate.

(b) *Effect of ambient temperature.* With the heating intensity kept constant using a 300 W bulb and the duration of each burst of heat maintained at 3 sec, a group of six mice were exposed for 1 hr trials at ambient temperatures of -10 , 0 , $+10$ and $+20^{\circ}\text{C}$ presented in random order. Each mouse received one trial each day and was exposed twice to each temperature. The rate of responding declined with the rise in ambient temperature.

(c) *Effect of duration of each burst of heat.* With the ambient temperature maintained at $0^{\circ}\text{C} \pm 1.5^{\circ}\text{C}$ and the heating intensity constant from a 300 W bulb, the duration of each burst of infra-red heat was varied between 1 and 7 sec. Each trial at each duration lasted 1 hr and the different durations were presented in different trials in random order. Each mouse was given two trials at each duration. The results show that the rate at which the mice responded declined with increasing duration of each burst.

(d) A group of six mice were trained to respond with the apparatus arranged so that the infra-red lamp remained on for so long as the mouse held the lever depressed. The time for which the mice held the lever down was recorded. At a constant temperature of $0^{\circ}\text{C} \pm 1.5^{\circ}\text{C}$ the intensity of heat received was varied during 1 hr trials by using bulbs of 150, 250 or 300 W. The different wattages were presented in random order and each mouse was exposed for five trials at each wattage. The results show that the mice turned the heat on for the longest period with the 150 W bulb and for the shortest period with the 300 W bulb. The 250 W bulb was turned on for an intermediate time.

(e) A group of hairless mice which had been trained to respond for infra-red heat had the infra-red bulb replaced by a red electric light bulb. To prevent any heat reaching the mice a sheet of Perspex was interposed between the bulb and the mouse. After a few trials lasting $\frac{1}{2}$ hr each, the rate of responding had markedly declined.

The results demonstrate that behavioural thermoregulation in mice is influenced by intensity of heating, ambient temperature and the duration of each burst of radiant heat. It has also been demonstrated that the mice were responding for the heat and not the illumination provided by the infra-red bulbs.

REFERENCE

WEISS, B. & LATIES, V. G. (1961). Behavioural thermoregulation. *Science, N.Y.* **133**, 1338-1344.

Heat loss from young pigs, individually and in groups, at ambient temperatures of 9, 20 and 30° C

By C. W. HOLMES and L. E. MOUNT. *Institute of Animal Physiology, Babraham, Cambridge*

Two direct calorimeters have been used in this work. The larger calorimeter is built in the form of a pig pen within a controlled temperature chamber, and has been used to measure continuously heat losses from groups of pigs living in it for long periods of time (Holmes, Legge, Mount & Start, 1964). Non-evaporative heat loss is measured as the rise in temperature of cooled water due to its passage through a heat exchanger mounted within the calorimeter. Air temperature within the calorimeter is kept at the same constant level as that in the controlled temperature chamber by adjusting the rate of heat removal in the heat exchanger. This is achieved by a resistance thermometer, which monitors the calorimeter air temperature and regulates through a silicon-controlled rectifier the power input to an immersion heater in the water line, and so controls automatically the temperature of the water arriving at the heat exchanger.

A smaller calorimeter has also been built within a controlled temperature chamber, and it has been used for short-term (3-4 hr) observations with individual pigs. Non-evaporative heat loss is measured by a thermopile as the mean temperature gradient across the calorimeter walls.

The evaporative heat transfer from both calorimeters is measured as the increment of water vapour in the ventilating air passing through the calorimeter; the quantity of water vapour determined in this way is converted to evaporative heat by multiplying it by the appropriate value for the total heat of evaporation, in this case 0.61 kcal/g water vapour. The

increment of water vapour in the ventilating air is estimated from the difference between the water vapour pressures of the ingoing and outgoing air, determined from wet- and dry-bulb temperatures of both air streams, and the ventilation rate.

The calorimeters have been tested by dissipating measured quantities of non-evaporative and evaporative heat within them and determining these quantities from the calorimetric measurements. The mean coefficient of variation for the measurement of total heat loss by both calorimeters was 2.3 %.

Heat losses from groups of six pigs of approximately 20 kg body weight and groups of three pigs of approximately 60 kg body weight have been measured at 9, 20 and 30° C ambient temperatures. Heat loss has been measured from similar pigs individually at the same three ambient temperatures.

In two experiments with groups of pigs at 20° C, in which the food allowance was increased in proportion to body weight, heat loss was found to be proportional to (body weight)^{1.0} over the weight range 17–35 kg; the corresponding exponent of body weight over the weight range 20–54 kg was 0.9. In five experiments in which pigs weighing approximately 60 kg received only twice as much food as pigs weighing approximately 20 kg, the mean value for the exponent was 0.7 over the weight range 17–64 kg.

TABLE 1. Heat loss, kcal/kg hr, for resting pigs

Body weight (kg)	Ambient temperature (° C)		
	9	20	30
Groups			
20	2.91	2.64	2.58
60	2.14	1.95	1.95
Individuals			
20	3.77	2.71	2.46
60	2.27	1.91	1.73

TABLE 2. Evaporative heat loss as percentage of total heat loss (figures in brackets: mean respiratory rate per min)

Body weight (kg)	Ambient temperature (° C)		
	9	20	30
20	8.5 (19)	13.2 (16)	30.5 (65)
60	7.8 (13)	12.9 (13)	25.2 (40)

The groups of pigs were fed twice daily at 9.30 a.m. and 5.30 p.m.; the records of heat loss were analysed in periods of 6 hr, the 24 hr day starting at 3 a.m. The heat loss exhibited a marked 24-hr rhythm in all experiments, the maximum rate occurring during 3 p.m. to 9 p.m. and the minimum rate during 3 a.m. to 9 a.m. At 20° C the mean amplitude of the

cycle was 22% of the mean rate; this tended to be larger at the lower ambient temperature.

In each experiment the pig or group of pigs was first exposed to 20° C and then either 9 or 30° C; in this way the animals served as their own controls. The mean effect of ambient temperature on heat loss from resting pigs is shown in Table 1. These results show the modification of heat loss at the low ambient temperature due to the grouping together of pigs.

The technique adopted for the measurement of heat loss from individual pigs allowed the total heat loss to be partitioned into its non-evaporative and evaporative components; these results are given in Table 2.

REFERENCE

HOLMES, C. W., LEGGE, A. J., MOUNT, L. E. & START, I. B. (1964). *J. Physiol.* **175**, 30-31P.

The use of a thermal gradient layer in the measurement of heat loss from new-born pigs to the floor

By A. J. LEGGE and L. E. MOUNT. *Institute of Animal Physiology, Babraham, Cambridge*

A copper-constantan gradient layer was made by winding a flattened spiral of 20 turns of constantan ribbon, 3 mm wide and 0.1 mm thick, on to strips of 'Tufnol', each 38 × 2 cm, and 0.4 mm thick. The strip was then half-immersed on edge in acidified copper sulphate solution, and the immersed part of the constantan copper-plated. This produced copper-constantan junctions on both sides of the strip, so that one complete turn of the constantan spiral constituted a thermocouple. Seventeen such strips were mounted side by side and connected in series electrically, ensuring that for all the strips the thermo-electric e.m.f.'s in response to heat-flow would be in the same sense. The strips were then embedded in 'Welvic' paste (Imperial Chemical Industries, Ltd.) to make a mat 40 × 37 × 0.4 cm thick. The method of calibration and the operation of the mat will be demonstrated.

In the experiments with pigs, the animal was placed on the mat, which was resting either on concrete (2.5 cm thick), wood (1.27 cm thick) or expanded polystyrene (2.5 cm thick). The ambient temperature range was 18-30° C.

The animal's posture had a marked effect on heat loss to the floor; the high heat loss associated with a relaxed posture decreased considerably as the animal moved to a more tense posture in which it was supported on its limbs. When the ambient temperature changed from 30 to 20° C, heat loss to each type of floor nearly doubled. The heat loss to concrete at 30° C was rather greater than to wood at 20° C; substitution of wood for concrete

was equivalent to raising the floor temperature by 12° C. A 2.5 cm thickness of wood shavings on concrete was equivalent to a rise of 9° C on a floor of bare concrete; 2.5 cm of straw corresponded to a 15° C rise, and 2.5 cm of woodwool to 19° C. On bare concrete, about 15% of the newborn pig's total heat loss is by way of the floor; on wood it is 6%, and on expanded polystyrene, 2%.

The results of this investigation are being published in full elsewhere (Mount, 1966).

REFERENCE

MOUNT, L. E. (1966). *Res. vet. Sci.* (In the Press.)

Studies on potassium excretion in the sheep

By J. K. DEWHURST and F. A. HARRISON. *Institute of Animal Physiology, Babraham, Cambridge*

Clun Forest ewes aged 1½–2 years, body weights between 40 and 50 kg, were surgically prepared with permanent rumen fistulae and were acclimatized to a dry diet of 1000 g chaffed hay and 200 g crushed oats given as one feed between 8.45 and 9.15 a.m. daily. Water was allowed *ad libitum* and there was free access to a mineral salt lick except when the animals were under experiment. For experimental observations the sheep were placed in metabolism cages which allowed the separate collection of urine and faeces. The animals received the same ration but from a well-mixed bulk supply sufficient to last for the period of observation. After 3–5 days in the metabolism cage to allow the sheep to become accustomed to the experimental routine, observations were made on the normal urinary and faecal excretion of Na, K and Cl and the responses to intraruminal administration of either 1 l. of glass-distilled water (control) or 1 l. of (a) 250 mM-KCl, or (b) 250 mM-K acetate, or (c) 125 mM-NaCl, or (d) 125 mM-Na acetate. Daily food and water consumption were recorded as well as urine and faeces output.

Urine was either collected in the separator of the metabolism cage for periods of 6, 12 or 24 hr or by continuous drainage from the urinary bladder by an indwelling Foley catheter, when hourly collections were made. Catheterization was performed under epidural procaine anaesthesia in the afternoon of the day before experiment. The urethral meatus was visualized with the aid of a modified Cusco vaginal speculum and a head-lamp. Random samples of faeces were obtained from 24 hr collections in the polythene receiver of the metabolism cage, after weighing the total output.

The daily food supplied 400 to 600 m-moles K and 50–60 m-moles Na. Approximately 87–94% of the total K recovered in urine and faeces was

excreted in the urine, whereas 80–98% of the total Na recovered was found in the faeces. Goodall & Kay (1965) found faecal potassium concentrations increased significantly when 458 m-moles K was given daily as a mixture of salts. In our experiments when a single dose of 250 m-moles K was given *per fistulam*, 80% of the increased K load was excreted in urine in the following 24 hr with no significant alteration in faecal K excretion.

Collection of urine at 6 hr intervals showed that after feeding the urinary K excretion increased in the periods 6–12 and 12–18 hr. The administration of 250 m-moles K as chloride or acetate caused an earlier rise in the urinary K excretion. Hourly collections of urine by bladder catheter confirmed the delay observed in the excretion of dietary potassium. K excretion and urine volume were low in the 2–3 hr after feeding. Stacy & Brook (1964) have described an antidiuresis in the sheep following feeding, however, when viewed in the context of 24 hr excretion patterns we found the major effect to be a diuresis before feeding. Thus the mean urine volume in the 48 hr preceding five control experiments was 0.76 ml./min; in the hour before feeding 2.38 ml./min; and in the first full hour after feeding 0.71 ml./min. When KCl or K acetate was given the delay in K excretion though reduced was not abolished, 1–2 hr elapsing before any marked rise in K excretion appeared.

Anderson & Pickering (1962) noted a rise in Na excretion in response to intravenous K infusion in the cow. A similar effect has been reported in response to intravenous K infusion in the dog (Berliner, Kennedy & Orloff, 1951) and to oral K in man (Liddle, Bennett & Forsham, 1953). In our experiments increased K excretion induced by K administration *per fistulam* was also accompanied by Na excretion. In those experiments where Na loads were given only 25% of the sodium was excreted in the following 24 hr.

REFERENCES

- ANDERSON, R. S. & PICKERING, E. C. (1962). *J. Physiol.* **164**, 180–188.
BERLINER, R. W., KENNEDY, T. J. & ORLOFF, J. (1951). *Am. J. Med.* **11**, 274–282.
GOODALL, E. D. & KAY, R. N. B. (1965). *J. Physiol.* **176**, 18–19P.
LIDDLE, G. W., BENNETT, L. L. & FORSHAM, P. H. (1953). *J. clin. Invest.* **32**, 1197–1207.
STACY, B. D. & BROOK, A. H. (1964). *Aust. J. agric. Res.* **15**, 289–298.

Infusion and blood sampling techniques for use in minimally restrained goats

By J. L. LINZELL. *Institute of Animal Physiology, Babraham, Cambridge*

Jugular vein blood is easily obtained in ruminants but is unsuitable for some metabolic work because of the loss of components (e.g. water, Blackwood & Stirling, 1932, and fatty acids, Hartmann & Lascelles, 1965)

to the head. Repeated sampling of arterial blood requires the construction of a carotid loop, but for many purposes pulmonary artery (P.A.) or right ventricle (R.V.) blood is equally suitable and these sites can be reached via a catheter passed down a jugular vein (Chauveau & Marey, 1861).

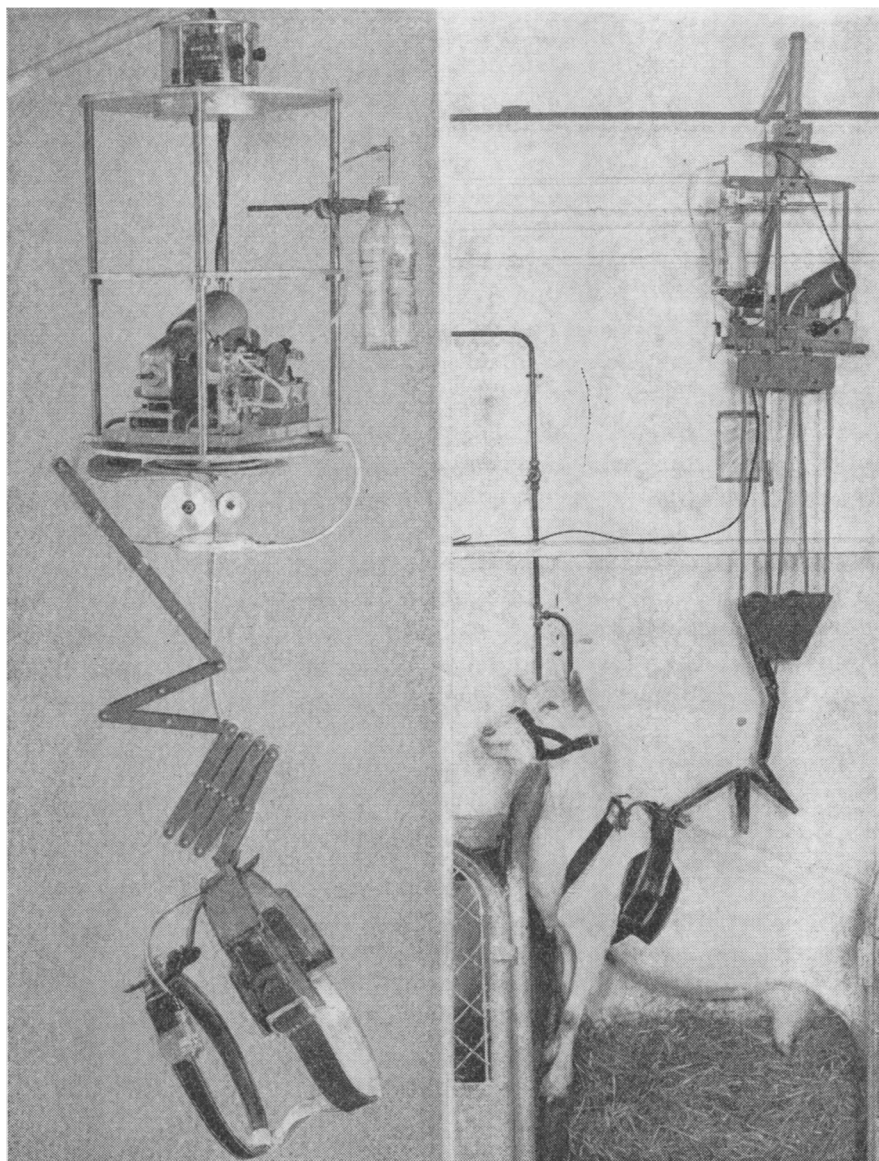

Fig. 1

In goats weighing 22–92 kg a catheter 2 mm outside diameter (Portland Plastics, non-toxic P.V.C. Shore hardness scale 90), was inserted into a jugular vein 16–24 cm from the point of the sternum of the standing animal. The P.A. was reached after introducing 35–55 cm of catheter, 81–33 cm beyond the point of sternum. The variation was largely due to the fact that the soft plastic seldom took the most direct route and the pressure was monitored to identify the position of the tip. The R.V. was recognized by large pressure fluctuations and the P.A. by the steady rise of blood in the open catheter to a height of 17–35 cm. In thirteen goats the position of the catheter was checked *in situ*. In nine it was passed under anaesthesia (animal lying on its side or back), and in seven was found in the P.A.; in two the catheter had looped round in the R.V. and in one had come out into the caudal vena cava. In four animals, catheterized conscious and standing, the catheter tip was in the P.A.

In forty-five experiments on thirteen conscious animals the cannulae have been left in the R.V. or P.A. for up to 12 hr without ill effect. However, in two anaesthetized animals fibrin formed on the catheter and one died from pulmonary embolism after 3 hr. Catheters examined *in situ* after days or weeks in the jugular vein were usually embedded in thrombus, although still patent, and no ill effect has been seen from withdrawing them. However, when a mammary vein was recatheterized after 5 days a thrombus was dislodged and the goat died.

The apparatus of Jewell (1957) has been adapted to carry out prolonged infusions and repeated blood sampling in animals free to move at will in their own pens. Infusion and sampling catheters are attached to Luer-Lok taps on the loose collar of a leather harness worn by the animal. Pumps and other apparatus are placed on a swivelling platform, with rotary electrical contacts, suspended over the pen and plastic tubing and recording wires pass down through a flexible metal tube to the harness. Slack in the metal tube is taken up when the animal moves, either by a system of weighted pulleys, or on a spring loaded drum. Unrestrained goats can, with teeth, feet and body, break, move, and remove unprotected taps and catheters, not fixed to the skin, and require loose clothing outside the harness to defeat their ingenuity.

I am most grateful to Mr I. R. Fleet for technical assistance and help, with the Institutes workshop, in the design of the apparatus.

REFERENCES

- BLACKWOOD, J. H. & STIRLING, J. D. (1932). *Biochem. J.* **26**, 357–361.
CHAUVEAU, J. P. A. & MAREY, E. J. (1861). *C.r. held. Séanc. Acad. Sci., Paris* **53**, 622–625.
HARTMANN, P. E. & LASCELLES, A. K. (1965). *Aust. J. ex. biol. Sci. med.* **18**, 114–123.
JEWELL, P. A. (1957). *J. Physiol.* **135**, 21–22P.

A histochemical study of the innervation of the mammary glands

By CATHERINE O. HEBB and J. L. LINZELL *A.R.C. Institute of Animal Physiology, Babraham, Cambridge*

It is well recognized that sympathetic adrenergic fibres of skin nerves supply the smooth muscle of the teat as well as some of the mammary blood vessels (Linzell, 1959*a*). Some workers have suggested that, in addition, the mammary glands have a parasympathetic cholinergic innervation. The evidence for this is that some parasympathomimetic agents, including acetylcholine, can cause ejection of milk and that, in ruminants, the udder receives part of its nerve supply from the sacral outflow. However, Linzell (1959*b*) found that parasympathetic fibres leave the sacral nerves within the pelvis, and that sympathetic fibres run in them to the udder, and could find no evidence for a cholinergic autonomic innervation in goats and sheep. Bunch & Ballantyne (1966) using cholinesterase histochemistry in rabbits could only detect acetylcholinesterase positive structures near the sebaceous glands of the teat.

We have now investigated the rabbit mammary gland by the method of Koelle for cholinesterases and by that of Falck & Owman for catecholamines as modified by Hebb, Mann & Perkins (1966), to permit the examination of adjacent sections by the two methods.

Noradrenaline (CA) containing fibres were found in the smooth muscle of the teat and arteries, the teat being richly innervated. No fibres containing CA were found in any part of the glandular (i.e. alveolar) tissue. In a denervated gland the teat muscle was found to be relaxed, the teat ducts widely dilated and no CA fibres were found.

Acetylcholinesterase (AChE) was found in a few sections just beneath the epidermis. No nerves containing AChE appeared to penetrate the substance of the gland or innervate its smooth muscle. Butyrylcholinesterase (BuChE)-containing nerve fibres were found abundantly amongst the smooth muscle and dermis in the teat and some were found in interlobar connective tissue often near ducts. There were no BuChE-containing fibres within the lobules. Their distribution suggests that they are sensory and it may be that they stain so distinctly because of BuChE associated with their myelin.

Our preliminary findings therefore support physiological evidence that mammary tissue proper receives only adrenergic motor fibres and a few sensory nerves near large ducts.

We are grateful to Mr S. P. Mann for careful technical assistance.

REFERENCES

- BUNCH, G. A. & BALLANTYNE, B. (1966). *J. Anat.* **100**, 441.
HEBB, C. O., MANN, S. P. & PERKINS, H. D. (1966). *J. Physiol.* **184**, 12-13P.
LINZELL, J. L. (1959a). *Physiol. Rev.* **39**, 534-576.
LINZELL, J. L. (1959b). *Q. Jl exp. Physiol.* **44**, 160-176.

A diagonal technique for the detection of phosphoserine-peptides

By CELIA DE MILSTEIN. *Institute of Animal Physiology, Babraham, Cambridge*

Factors influencing secretion from the salt glands of the domestic duck

By R. W. ASH, J. W. PEARCE* and ANN SILVER. *Institute of Animal Physiology, Babraham, Cambridge*

Schmidt-Nielsen (1960) considered that secretion from the salt gland of marine birds is due to stimulation of osmoreceptors in the central nervous system which activate cholinergic secretomotor fibres to the gland. The present experiments concern the relation between secretion and changes in plasma osmotic pressure, the effects of denervation of the gland and histochemical evidence for a cholinergic innervation.

Oral administration of hypertonic NaCl solution stimulated a continuous secretion in conscious Aylesbury ducks after 5-28 min, by which time plasma osmotic pressure and sodium concentration had increased by 2.4-8.7%. Secretion was reduced or abolished by the oral administration of water, and the inhibition coincided with a rapid and appreciable reduction in plasma osmotic pressure and Na⁺ concentration. Comparable or larger increases in total osmotic pressure produced by orally administered hypertonic KCl solution or by intravenous injection of urea or dextrose failed to stimulate a maintained secretion. A superimposed Na⁺ load evoked a typical secretory response indicating that high plasma concentrations of urea, dextrose or K⁺ were not inhibiting secretion. The mechanism is not, however, specifically stimulated by Na⁺, since an intravenous injection of hypertonic sucrose initiated secretion within 2 min; this is the characteristic latency of the response to an intravenous injection of 10-15 ml. of 10% NaCl, the standard stimulus used in the subsequent experiments.

The 'secretory nerve' to the gland emerges from the sphenopalatine ganglion and enters the orbit to become associated with the ophthalmic division of the trigeminal nerve. Electrical stimulation of the 'secretory nerve' in ducks anaesthetized with ether, although inconsistently effective,

* Fellow of the Canadian Heart Foundation.

produced a secretion similar in volume and sodium content to that evoked physiologically, and both types of response could be temporarily abolished with atropine. In each of four ducks, one salt gland was removed and the other gland was denervated by undercutting with preservation of the blood supply, or by section of nerves in the orbit. The latter procedure involved removal of the junction of the secretory nerve with the ophthalmic branch of the trigeminal at which point there is a prominent cell collection. These procedures resulted either in the abolition or substantial reduction of the secretory response to subsequent intravenous injections of NaCl solution. Denervated glands could be induced to secrete by subcutaneous administration of carbamyl choline in doses of 5–50 μg ; the volume and sodium content of this secretion was usually augmented by a concurrent NaCl load.

Salt glands have been stained for cholinesterases by the methods of Coupland & Holmes (1957) and Lewis (1961). The substrates used were acetylthiocholine iodide and butyrylthiocholine iodide (L. Light & Co. Ltd.) and the inhibitors were DFP (kindly given by Dr B. C. Saunders), ethopropazine hydrochloride (May & Baker, Ltd.), BW 284C51 and BW 62C47 (Wellcome Research Laboratories). Both acetylcholinesterase (AChE) and butyrylcholinesterase were present in the gland but AChE predominated. There was no obvious difference in the activity or distribution of the enzymes in glands from non-secreting and secreting ducks (cf. Fourman, 1966). Most, if not all the AChE activity appeared to be associated with nerves and the choline acetylase activity (kindly estimated by Dr Catherine Hebb) in a sample of a gland was 400 μg ACh/g fresh tissue/hr, a value consistent with a cholinergic innervation. The stained fibres could be traced into the gland from the ganglionic region of the 'secretory nerve'; they appeared to be continuous with the AChE-containing network in the centre of each lobule. The stained elements ran between the columns of secreting cells and also along the walls of the ducts. At the periphery of the lobules the staining was often associated with a series of looped structures, the distribution of which was very similar to but not identical with the pattern of blood vessels demonstrated by injected carmine-gelatine. Complete denervation of the gland led to total or almost total loss of cholinesterase staining. In the one partially denervated gland analysed the choline acetylase activity was reduced to 33 μg ACh/g fresh tissue/hr. The stained nerve fibres appeared to arise from cells located in the ganglion and along the course of the 'secretory nerve'.

Our results support the concept of a cholinergic secretomotor mechanism and imply that any hormonal factors (Phillips, Holmes & Butler, 1961) which may exist in the presence of a salt load cannot produce secretion unless the nerve supply is intact.

REFERENCES

- COUPLAND, R. E. & HOLMES, R. L. (1957). *Q. Jl microsc. Sci.* **98**, 327-330.
FOURMAN, J. (1966). *J. Anat.* **100**. (In the Press.)
LEWIS, P. R. (1961). *Bibliothca anat.* **2**, 11-20.
PHILLIPS, J. G., HOLMES, W. N. & BUTLER, D. G. (1961). *Endocrinology* **69**, 958-969.
SCHMIDT-NIELSEN, K. (1960). *Circulation* **21**, 955-967.

The *in vitro* transfer of bovine immune lactoglobulin across small intestines of new-born pigs

By A. E. PIERCE and M. W. SMITH. *Institute of Animal Physiology, Babraham, Cambridge*

The new-born pig acquires a passive immunity by the intestinal absorption of ingested immune globulin which is present in the sow's colostrum. During the first few hours *post partum* the pig small intestine will absorb other macromolecules (Lecce, Matrone & Morgan, 1961; Hardy, 1965) and the process of transfer is therefore spoken of as being non-selective. The present work describes a technique whereby the whole process of protein transfer can be examined *in vitro* using everted sacs of new-born pig small intestine.

In preliminary experiments, the entry of protein into mucosal cells was effected *in vivo* and only the exit was studied *in vitro*. In these cases bovine colostrum, dialysed previously against bicarbonate saline (Krebs & Henseleit, 1932), was fed (2.1 ml./100 g body weight; 4.5% (w/v) bovine immune lactoglobulin) and the small intestine removed 90 min later. Ten everted sacs were prepared along the total length of the small intestine and these were incubated in bicarbonate saline at 37° C for a total period of 2 hr, during which time the mucosal solutions were equilibrated with 95% O₂ + 5% CO₂. Bovine immune lactoglobulin, estimated in serosal fluids by the method of Gell (1957), was found in all but the last two sacs with maximal transfer in sacs 5 and 6 (800 µg/g intestine/hr incubation).

In further experiments, the small intestine of new-born pigs, taken immediately after birth, was everted and incubated directly in dialysed bovine colostrum. Again the amount of protein transferred by the middle segments of small intestine exceeded that measured at either end. Maximal transfer was across segment 6 (45 µg/g intestine/hr incubation). This was about 16 times less than that found after colostrum had been fed to the pig. Human serum albumin present in bovine colostrum in equal concentration with bovine immune lactoglobulin (5.4% (w/v) of each protein) reduced by six-fold the transfer of bovine immune lactoglobulin across segment 7 of the small intestine. Albumin was itself transferred to the serosal fluid under these conditions with maximal transfer across segment 6. Given an equal opportunity, on the basis of weight, of transferring albumin or

globulin, segment 6 transferred 9 times more albumin than globulin (i.e. over 20 molecules of albumin for each molecule of globulin). This effect of albumin on the absorption of globulin was not observed *in vivo* (Pierce & Smith, 1966).

The transfer of immune lactoglobulin was next measured in the presence of different L-amino acids. Segments 6 and 7 only were everted and incubated in dialysed bovine colostrum as before, but one set of sacs was incubated in colostrum containing an added amino acid in a concentration of 10 mM. L-Leucine and L-methionine, but not L-alanine, significantly inhibited the transfer of bovine immune lactoglobulin. L-leucine also inhibited the transfer of both fluid and glucose. The D-isomers of these amino acids had no effect on the transfer of protein.

The ability of human serum albumin and some, but not all, L-amino acids to inhibit the rate of transport of bovine immune lactoglobulin across pig small intestine implies a degree of specificity in the protein-transferring mechanism which had not been previously suspected.

REFERENCES

- GELL, P. G. H. (1957). *J. clin. Path.* **10**, 67-71.
HARDY, R. N. (1965). *J. Physiol.* **176**, 19-20P.
KREBS, H. A. & HENSELEIT, J. (1932). *Hoppe-Seyler's Z. physiol. Chem.* **210**, 33-66.
LECCE, J. G., MATRONE, H. & MORGAN, D. O. (1961). *J. Nutr.* **73**, 158-166.
PIERCE, A. E. & SMITH, M. W. (1966). Submitted for publication.

Ovarian autotransplantation with vascular anastomoses, and its application to the study of reproductive physiology in the ewe

By J. R. GODING. *Institute of Animal Physiology, Babraham, Cambridge*

Investigation of ovarian function by the sampling of ovarian venous effluent has hitherto been limited to needling or short-term cannulation procedures. No method is available for infusing into the ovarian artery in the intact animal.

By making autotransplants with vascular anastomosis, it is possible to obtain access to both arterial and venous aspects of the adrenal circulation (McDonald, Goding & Wright, 1958) and this preparation has yielded useful information about adrenal function (Blair-West, Coghlan, Denton, Goding, Wintour & Wright, 1963). This demonstration presented the successful application of similar techniques to the ovary, the developmental work being carried out while working at the Worcester Foundation for Experimental Biology, Shrewsbury, Mass.

The operation is carried out in two stages. First, a combined carotid artery-jugular vein skin loop is made (Goding & Wright, 1964), and some

weeks later the ovary is transplanted. The arterial anastomosis is performed by the patch method of Carrel & Guthrie (1906). A plaque of aorta which includes the origin of the ovarian artery is inlaid into the carotid artery. The venous connexion is made by end-to-side anastomosis of the middle uterine vein into the jugular vein.

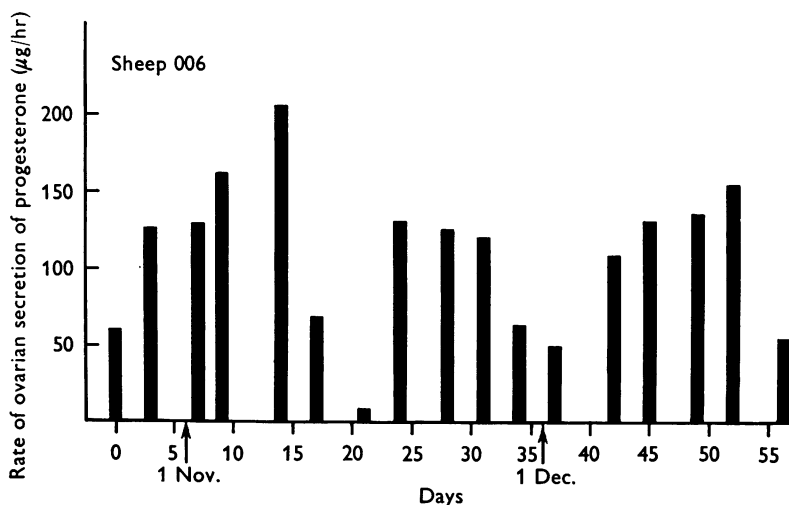

Fig. 1. Periodic variation in ovarian secretion rate of progesterone in a ewe with an ovarian transplant.

The functioning of such transplants has been studied by angiography, histology and by analysis of the venous effluent. One transplanted ovary, removed after 33 days, showed numerous follicles in various stages of development and a well marked corpus luteum. In another animal, ovarian vein blood was collected twice weekly for 8 weeks. Figure 1 shows cyclical changes in progesterone secretion; the period was about 20 days. This experiment illustrates one sort of information that may be obtained during long term studies on such a preparation.

REFERENCES

- BLAIR-WEST, J. R., COGHLAN, J. P., DENTON, D. A., GODING, J. R., WINTOUR, M. & WRIGHT, R. D. (1963). *Recent Progr. Hormone Res.* **19**, 311-383.
 CARRELL, A. & GUTHRIE, C. C. (1906). *J. Am. med. Ass.* **47**, 1648.
 GODING, J. R. & WRIGHT, R. D. (1964). *Aust. J. exp. Biol. med. Sci.* **42**, 443-448.
 McDONALD, I. R., GODING, J. R. & WRIGHT, R. D. (1958). *Aust. J. exp. Biol. med. Sci.* **36**, 83-96.

Transplantation of the ovary

By J. R. GODING. *Institute of Animal Physiology, Babraham, Cambridge*

The control of the secretory activity of the corpus luteum

By J. S. PERRY and R. B. HEAP. *Institute of Animal Physiology, Babraham, Cambridge*

COMMUNICATIONS

Ventilatory capacity in normal Bhutanese

By J. E. COTES and M. P. WARD. *Thames Group of Hospitals, London and Pneumoconiosis Research Unit of the Medical Research Council, near Cardiff*

This study extends knowledge of ethnic variation in ventilatory capacity to Bhutanese living in an isolated valley at 12,000 ft. Sixty-nine subjects were studied, of whom one was deaf and dumb and one had portal cirrhosis. Of the remainder five were smokers; none gave a history of chest illness.

The forced expiratory volume ($FEV_{1.0}$) and forced vital capacity (FVC) were measured by M.P.W. using a dry spirometer (Collins, McDermott & McDermott, 1964) and standardized technique, at an average temperature of 12° C (Table 1).

The data for men are described by the following significant linear regressions on age and height:

$$FEV_{1.0} \quad 1 \text{ BTPS} = 3.7 \text{ ht} - 0.022 \text{ age} - 1.66 \quad \text{s.D. } 0.60$$

$$FVC \quad 1 \text{ BTPS} = 5.8 \text{ ht} - 0.020 \text{ age} - 4.05 \quad \text{s.D. } 0.72$$

$$\frac{FEV}{FVC} \times 100 \% = 82.6 - 0.218 \text{ age} \quad \text{s.D. } 7.92$$

For women the regression coefficients on age but not height are significant, whereas neither are significant for the children.

TABLE 1. Mean values for forced expiratory volume ($FEV_{1.0}$) and forced vital capacity (FVC) of normal Bhutanese (B) compared with subjects of Western European descent (E) of the same age and size distribution (Cotes, 1965)

		Adult males	Adult females	Adolescents
Number		38	13	16
Age (yr)	Mean	38.8	35.7	15.4
	Range	20-69	22-61	11-19
Height (m)	Mean	1.68	1.63	1.50
	Range	1.43-1.79	1.59-1.69	1.28-1.77
$FEV_{1.0}$, 1 (BTPS)	(B)	3.63	3.08	2.53
	(E)	3.45	2.66†	2.56
FVC, 1 (BTPS)	(B)	4.92	3.86	3.15
	(E)	4.29†	3.17†	2.82‡
$\frac{FEV}{FVC} \times 100$ (%)	(B)	74.1	80.2	80.4
	(E)	77.2‡	82.8	86.6

Symbols indicate significant differences † $P < 0.01$, ‡ $P < 0.05$.