

Stability of the human dystrophin transcript in muscle

Christine N. Tennyson^{1,2}, Qinwei Shi² and Ronald G. Worton^{1,2,*}

¹Molecular and Medical Genetics Department, University of Toronto and ²Genetics Department and Research Institute, Hospital for Sick Children, 555 University Avenue, Toronto, Ontario M5G 1X8, Canada

Received February 29, 1996; Revised and Accepted June 21, 1996

ABSTRACT

The human dystrophin gene has 79 exons spanning >2300 kb making it the largest known gene. In previous studies we showed that ~16 h are required to transcribe the gene in myogenic cultures [Tennyson, C.N., Klamut, H.J. and Worton, R.G. (1995) *Nature Genet.* 9, 184–190]. To estimate the half-life of the dystrophin mRNA, the decay of the transcript was monitored by quantitative RT-PCR in cultured human fetal myotubes following exposure to actinomycin D. Results from this analysis indicated that the half-life of the dystrophin mRNA is 15.6 ± 2.8 h in these cultures. Transcript accumulation profiles were predicted using a mathematical model which incorporated the measured half-life. The modeled accumulation profiles were consistent with observed profiles supporting the half-life measured using actinomycin D. The kinetic model was then used to predict the relative amount of nascent and mature dystrophin transcript at steady state. Measurements by quantitative RT-PCR indicated that in adult skeletal muscle tissue the concentration of mature dystrophin mRNA is 5–10 molecules per nucleus, demonstrating, as expected, that it is a low abundance transcript. Furthermore the ratio of nascent to mature dystrophin transcript indicated that dystrophin synthesis may not be at steady state in the adult skeletal muscle we tested. Alternatively, the kinetics of transcript production in skeletal muscle tissue may be different from those observed in cultured fetal myogenic cells.

INTRODUCTION

The human dystrophin gene is uniquely characterized by its immense size with 79 exons spanning a physical distance of >2300 kb (2–4). In our previous report, the time required for transcription of the gene was determined by monitoring transcript accumulation at the 5'- and 3'-ends following induction of expression in myogenic cultures (1). These studies showed that RNA polymerase takes ~12 h to traverse from exon 3 to exon 69, and this predicted a transcription time of 16 h for the entire gene.

Analysis of dystrophin transcript accumulation showed differences in the profiles of transcript accumulation for the 5'- and 3'-ends of the gene, with a lower rate of accumulation at the

3'-end (1). The accumulation profile of a transcript is dictated by the rate of synthesis and the rate of decay of the transcript. The rate of decay of different mRNAs varies considerably as exemplified by the half-lives of the granulocyte-monocyte colony stimulating factor (GM-CSF) and the B-globin mRNAs which are 30 min and >17 h, respectively (5,6). Although much work has been carried out to determine sequence elements that influence the stability of a specific mRNA and success has come with the identification of destabilizing elements (7), it is not possible to predict the stability of an mRNA from its sequence (8).

To better understand the events dictating dystrophin transcript accumulation the half-life of the mRNA was measured in cultured myogenic cells. The cells were treated with actinomycin D, an inhibitor of transcription, and the subsequent decay of the transcript was monitored by quantitative RT-PCR. This approach indicated that the half-life is 15.6 ± 2.8 h. Using the measured half-life the profile of early transcript accumulation was modeled for the dystrophin gene and then compared to the accumulation curve observed in our previous study (1). The observed and predicted accumulation profiles were similar, supporting the half-life measured using actinomycin D.

The amount of dystrophin mRNA in human muscle tissue was then measured by quantitative RT-PCR and shown, as expected, to be very low. It was possible to predict the half-life of the mRNA from the ratio of total (nascent plus mature) to mature dystrophin mRNA at steady state. We measured this ratio in adult skeletal muscle tissue and obtained a value nearly twice that predicted. Therefore in the adult skeletal muscle tissue we studied either dystrophin synthesis was not at steady state or the kinetics of transcript production in the adult tissue differs from the kinetics observed in fetal myogenic cultures.

MATERIALS AND METHODS

Human myogenic cell culture and muscle tissue

Clonal populations of myogenic cells prepared from muscle of a 10 week human fetus were used for experiments designed to measure the half-life of the dystrophin transcript. The procedures to prepare clonal human myoblast cultures have been described (9). A myogenic clone was expanded at low density in cloning medium [F12 medium (Gibco-BRL) containing 20% fetal bovine serum and one Bullet Kit (Clonetics) which includes 0.5 ml human epidermal growth factor (10 µg/ml), 5.0 ml insulin (100 mg/ml), 0.5 ml GA-1000 (gentamycin at 50 mg/ml and

* To whom correspondence should be addressed at: Genetics Department, Hospital for Sick Children, 555 University Avenue, Toronto, Ontario M5G 1X8, Canada

amphotericin at 50 µg/ml), 5.0 ml Fetuin (50 mg/ml), 0.5 ml dexamethasone (0.39 mg/ml) and 5.0 ml bovine serum albumin (50 mg/ml)]. The cells were then plated at high density in cloning medium, allowed to recover for 24 h, and then transferred to fusion medium [α -minimal essential medium (Gibco-BRL) containing 16 mM glucose, 2% fetal bovine serum, and 100 U/ml penicillin and 0.1 mg/ml streptomycin] to induce differentiation into multinucleated myotubes.

Fresh adult human muscle tissue was obtained from a deceased individual that was undergoing retrieval of organs for donation.

Preparation of total RNA

Total RNA was isolated from myogenic cultures as described (1). Total RNA was isolated from human muscle tissue using the procedure described for myogenic cultures or the protocol of Chomczynski and Sacchi (10). The RNA concentration was determined from OD (260 nm).

Construction of control templates for *in vitro* transcription

The construction of templates 1-2-46 from cDNA1-2 and 9-14-46 from cDNA9-14 has been described (1) and a schematic illustration of each construct is shown in Figure 1. The plasmid 1-2-46 contains dystrophin exons 1–11 and a 46 bp insertion in exon 3. The plasmid 9-14-46 contains dystrophin exons 68–75 and a 46 bp insertion in exon 69. The plasmid 59-70-118 shown in Figure 1 contains dystrophin cDNA sequences 9080–10 398 which includes a portion of exon 59, all of exons 60–69, and a portion of exon 70. It was constructed from the plasmid Dp71-118 which is a Bluescript vector (Stratagene) containing dystrophin exons 63–70 following the Dp71 first exon and a 118 bp insertion in exon 65. To make 59-70-118, the plasmid Dp71-118 was digested with *Sac*I to remove Dp71 exon 1 and downstream dystrophin cDNA sequences to position 9480 in exon 63. The remaining linear plasmid which contained dystrophin sequences 9480–10 398 was treated with T₄ DNA polymerase to create blunt ends for later cloning. A 0.4 kb *Bam*HI–*Sac*I insert containing dystrophin cDNA sequences 9080–9480 was isolated from the plasmid p9-14 (ATCC 57677) and treated with T₄ DNA polymerase to create blunt ends. The 0.4 kb DNA fragment was then ligated into the above plasmid and a clone containing the insert in the correct orientation (5'-end of cDNA near T7 promoter) was identified and used for cRNA production by *in vitro* transcription. The internal 4 bp of the *Sac*I site were removed by the treatment with T₄ DNA polymerase.

Preparation of cRNA from control template

Plasmids were isolated from bacteria by alkaline lysis and purified using equilibrium centrifugation in CsCl (11). Purified plasmid was linearized and control RNA (cRNA) was generated by *in vitro* transcription from a T7 promoter using the T7 MEGAscript kit (Ambion) as described (1). The concentration of cRNA was determined from OD (260 nm).

Quantitative RT-PCR

As a first step cDNA was made by reverse transcription of samples containing a known amount of cRNA and total muscle cell RNA. This was followed by PCR of a dilution series of these samples using a radiolabeled primer. The detailed conditions used for reverse

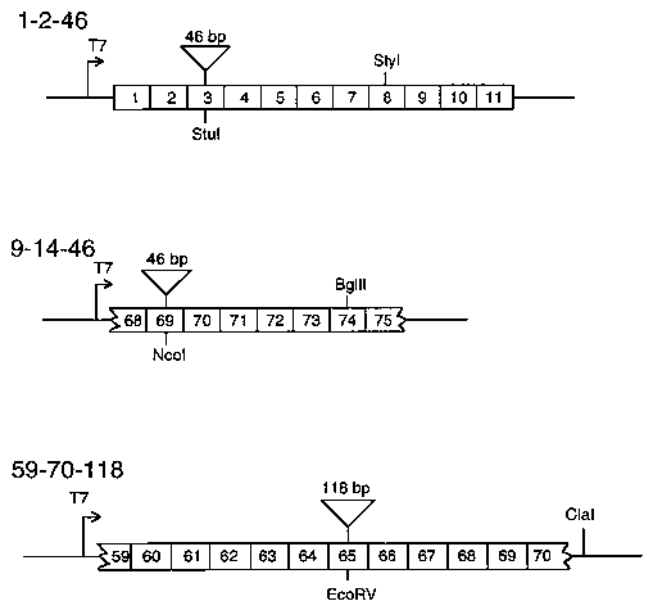

Figure 1. Schematic diagram of control templates 1-2-46, 9-14-46 and 59-70-118 used for *in vitro* transcription. Portions of the dystrophin cDNA have been positioned downstream of a T7 promoter. The dystrophin exons are represented as boxes and the exon number is shown inside the box. A small insertion of 46 or 118 bp has been added within the dystrophin sequences so the control RNA produced by *in vitro* transcription will differ slightly in size from the endogenous dystrophin transcript. The location of the insert and downstream restriction sites used to linearize the plasmid prior to *in vitro* transcription are indicated for each construct.

transcription and PCR have been described (12). The RT-PCR products were separated by non-denaturing polyacrylamide gel electrophoresis. The gels were dried and autoradiograms obtained. A Phosphorimager or a scanning laser densitometer and Imagequant software (Molecular Dynamics) were used to quantitate the amount of control and endogenous RT-PCR products.

RESULTS

Measurement of dystrophin mRNA half-life using actinomycin D

A classic approach for measuring the half-life of a transcript is to treat cells with actinomycin D, an inhibitor of transcription, and to monitor the subsequent decay of the transcript. The half-life of the dystrophin mRNA was measured in cultured myogenic cells in which dystrophin synthesis is developmentally regulated showing an increase during differentiation (13). Human fetal mononucleated myoblasts were plated in growth medium and 24 h later transferred to fusion medium to induce expression of the dystrophin gene with differentiation into multinucleated myotubes. The cultures were left in fusion medium for ~40 h and then exposed to 5 µg/ml actinomycin D. Control experiments established that this concentration of drug effectively inhibited >98% of transcription and had no visible effect on cell appearance over the time of the experiment. Total RNA was isolated from the myogenic cultures at different times following the addition of actinomycin D. Since dystrophin mRNA is relatively low in abundance, quantitative RT-PCR was used to monitor the decay of the transcript following exposure to the drug (Fig. 2).

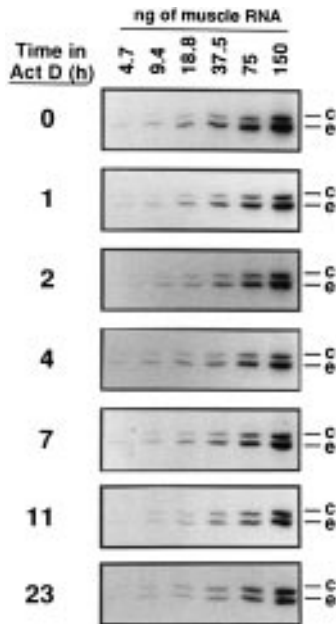

Figure 2. Monitoring the decay of dystrophin mRNA by quantitative RT-PCR. Total RNA was isolated from differentiated muscle cultures 0, 1, 2, 4, 7, 11 and 23 h following addition of actinomycin D. For each sample 1.5 μ g total RNA was combined with 3×10^5 molecules of cRNA synthesized from the control plasmid 59-70-118. The RNA was reverse transcribed using the reverse primer 70R (GGGATGCTTCGCAAATACC) and a serial dilution of the cDNA was amplified for 25 cycles using primer 70R and the forward primer 62F (ATCTCGCCAAACAAGTGCC). A total of 1×10^6 c.p.m. of end-labeled primer was included in each amplification reaction. The amplification products were separated on a 5% non-denaturing polyacrylamide gel and an autoradiograph of the gel is shown. The larger amplification product is generated from the control RNA (c) and the smaller product is generated from the endogenous dystrophin RNA (e).

Dystrophin RNA levels were quantitated by combining a known amount of total myogenic cell RNA with a known amount of a control RNA (cRNA) which served as an internal standard and co-amplifying by RT-PCR. The cRNA was identical to the endogenous dystrophin mRNA with the exception of a small insertion which allowed separation of the control and endogenous RT-PCR products by polyacrylamide gel electrophoresis. This cRNA was prepared *in vitro* by transcription from a T7 promoter in plasmid 59-70-118 which contains exons 59-70 of the dystrophin gene and has a 118 bp insertion in exon 65 (Fig. 1). Cellular RNA and control RNA were reverse transcribed using the primer 70R located in exon 70 and subsequently amplified using the same reverse primer and the forward primer 62F located in exon 62. Primers in these exons were chosen as they detect mRNA encoding full length dystrophin but not the mRNA encoding the small dystrophin isoform Dp71 which is transcribed from a promoter in intron 62 (14). This isoform is expressed at low but constant levels in differentiating myogenic cultures (Tennyson, C. and Worton, R. in preparation) but not in adult muscle tissue (14). Primers close to the 3'-end of the gene were chosen to ensure that a majority of the transcripts detected by the assay will be mature.

RNA samples isolated 0, 1, 2, 4, 7, 11 and 23 h following addition of actinomycin D were analyzed by RT-PCR to monitor

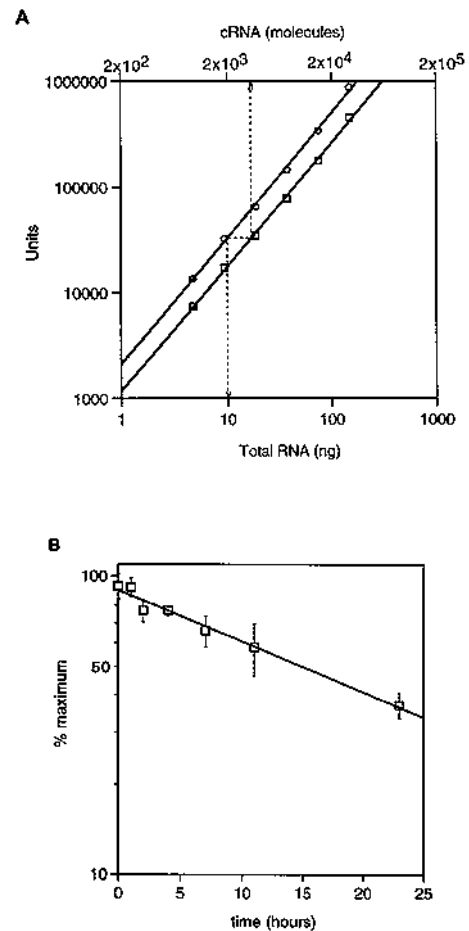

Figure 3. (A) For each sample quantitated by RT-PCR the amount of cRNA (molecules) and total muscle RNA (ng) were plotted against the amount of amplification product for the control (\square) and endogenous (\circ) RNA in units as measured by the phosphorimager. The linear increase shows the reaction is in the exponential range of amplification. The dashed line indicates ~ 3780 molecules of dystrophin transcript per 10 ng of total RNA in this sample prepared from a culture of fused myogenic cells that have been exposed to actinomycin D for 2 h (shown in Fig. 2). (B) The decay of the dystrophin mRNA was monitored for three different myogenic clones and each sample was analyzed in duplicate. The average percent maximum is plotted against the time in actinomycin D. The best fit line was determined by regression analysis. The error bars represent the standard deviation.

the decay of dystrophin mRNA (Fig. 2). In Figure 2 the larger product reflects the amount of control RNA (c) added to the sample (200 molecules cRNA/ng total cellular RNA) while the smaller product reflects the amount of endogenous dystrophin RNA (e) in the sample. The amount of endogenous dystrophin transcript decreases with time in actinomycin D as reflected in the decreasing intensity of the endogenous product with respect to the control. The amount of RT-PCR product was quantitated using the phosphorimager and this information was used to calculate the molecules of dystrophin RNA per ng of total cellular RNA for each sample (Fig. 3A). Three myogenic clones were analyzed in duplicate and the average is plotted against the time in actinomycin D (Fig. 3B). Based on these measurements the average half-life of the dystrophin transcript is 15.6 ± 2.8 h (where the calculated error is the standard deviation of three independent measurements).

Amount of dystrophin transcript in skeletal muscle tissue

The RT-PCR assay we developed for quantitation of the dystrophin transcript can be used to measure the absolute amount of transcript in skeletal muscle tissue. Previous studies by others have only determined relative transcript levels (15,16). Measurements made at the 3'-end of the transcript will determine the approximate amount of mature dystrophin mRNA while measurements made at the 5'-end of the RNA will determine the amount of total dystrophin transcript (nascent plus mature). The ratio of total to mature transcript in a cell is determined by the time required for transcription, the half-life of the mRNA, and whether the system is at steady state (see Appendix for detailed explanation). Using the time required for transcription, which we measured in our previous study (1), and a half-life of 15.6 ± 2.8 h in equation 1 (see Appendix) the ratio was predicted to be 1.5 (with a range of 1.4 to 1.6 using the standard deviation) at steady state. To gain some insight into the kinetics of dystrophin transcript production in skeletal muscle tissue we measured the abundance of both dystrophin mRNA and total (nascent plus mature) transcript in skeletal muscle tissue by quantitative RT-PCR.

To make these measurements, total RNA was isolated from four different tissue fragments obtained from the quadriceps muscle of an adult human. Dystrophin transcript levels were quantitated by RT-PCR using a primer pair near the 5'-end of the transcript in exon 3 (3F and 3R) which amplified both nascent and mature transcript and a second pair near the 3'-end of the transcript in exon 69 (69F and 69R) which amplified primarily mature transcript (Fig. 4A). Using a primer pair within one exon allows detection of all transcripts containing that exon regardless of whether splicing has occurred. It was demonstrated previously that splicing takes place cotranscriptionally (1), therefore a similar result would be predicted when using primers in adjacent exons detecting only spliced message.

As before, transcript levels were determined by combining a known amount of a control RNA with a known amount of total muscle RNA and co-amplifying by RT-PCR. The control product derived by *in vitro* transcription from plasmids 1-2-46 (exon 3) and 9-14-46 (exon 69) provided a standard against which the amount of endogenous dystrophin product was compared. The amount of endogenous RNA measured when using a primer pair in exon 3 is greater than the amount measured when using a primer pair in exon 69 (Fig. 4A). The ratio of control to endogenous products was quantitated using a scanning laser densitometer and graphical analysis allowed quantitation of dystrophin transcript levels (Fig. 4B and C). Table 1 summarizes the results of the analysis for exon 3 and 69 for each of the four muscle fragments. There is some variation in the absolute amount of dystrophin transcript per ng of total muscle RNA for each muscle fragment and this is likely because muscle tissue contains not only muscle fibers but also connective tissue and fat. On average there is 781 molecules of dystrophin mRNA per ng of total muscle RNA. The average measured ratio of exon 3-containing transcripts (nascent plus mature) to exon 69-containing transcripts (primarily mature) is 2.9 ± 0.9 . The ratio is somewhat variable although three of the four measured values are similar (2.1, 2.4 and 2.8) and perhaps a better estimate is 2.4 ± 0.4 . This ratio is somewhat greater than the value of 1.5 (with a calculated range of 1.4 to 1.6 using the standard deviation) predicted by the steady state model using a half-life of 15.6 ± 2.8 h and indicates an excess of nascent transcripts relative to mature.

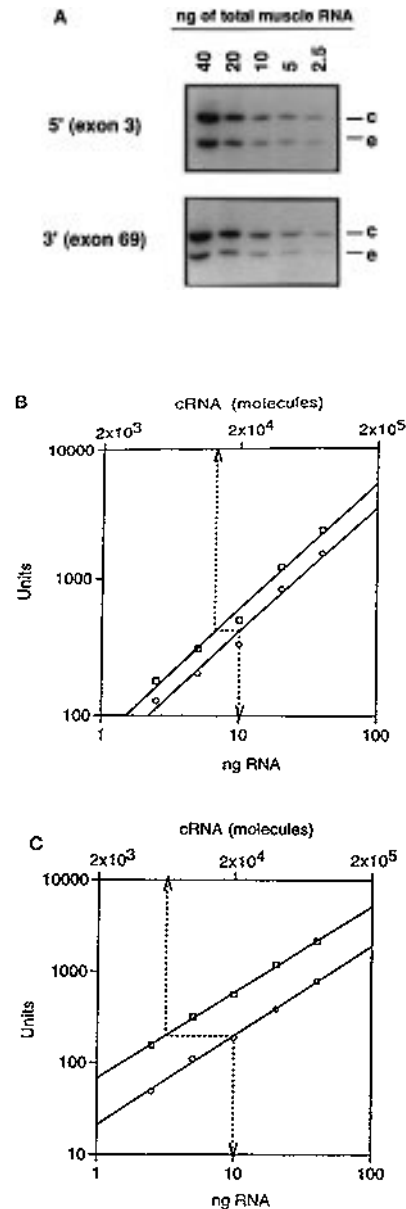

Figure 4. Determination of the amount of dystrophin transcript in adult human skeletal muscle tissue. (A) Total RNA was isolated from adult human skeletal muscle and 500 ng combined with 1×10^6 molecules of each of two cRNAs synthesized from the plasmids 1-2-46 and 9-14-46. cDNA was made by reverse transcription using primers 3R in exon 3 (CAGTTTTGCGCCTGTCAGGC) and 69R (GGAGTGCAATATTCACCAT) in exon 69. Serial dilutions of the cDNA were amplified for 23 cycles using a primer pair near the 5'-end of the transcript in exon 3 (3F; TTGCGAAGCAGCAACATATTGAG and 3R) and a primer pair near the 3'-end of the transcript in exon 69 (69F; TACAGGAGTC-TAAAGCACTT and 69R). Included in each reaction was 1×10^6 c.p.m. of end-labeled primer. The control (c) and endogenous (e) dystrophin amplification products were separated on a 12% non-denaturing polyacrylamide gel and an autoradiograph of the gel is shown. This shows the result obtained for sample 2 in Table 1. (B) The amount of cRNA and total muscle RNA were plotted against the amount of amplification product (units) for the control (\square) and endogenous (\circ) RNAs. In this example, the dashed line indicates approximately 1315 molecules of dystrophin transcript per ng of total muscle RNA when measuring near the 5'-end of the transcript (exon 3). (C) Similar analysis indicates ~629 molecules of dystrophin transcript per ng of total muscle RNA when measuring near the 3'-end of the transcript (exon 69). This shows the result obtained for sample 2 in Table 1.

Table 1. Amount of dystrophin transcript in skeletal muscle tissue

Sample	Nascent + mature 5' (exon 3) molecules/ng	Mature 3' (exon 69) molecules/ng	exon 3/exon 69 ratio
1	4866	1170	4.2
2	1315	629	2.1
3	1319	546	2.4
4	2141	778	2.8
Average	2410	781	2.9 ± 0.9

DISCUSSION

Stability of dystrophin mRNA

As cultured myoblasts differentiate to form multinucleated myotubes dystrophin gene expression is upregulated (13). Following an increase in transcription initiation, ~16 h are required for polymerase to traverse the entire dystrophin transcription unit in muscle (1). By monitoring the decay of the transcript in cultured human myotubes treated with actinomycin D we have shown that the half-life of this transcript is 15.6 ± 2.8 h.

In muscle the 14 kb dystrophin mRNA encodes a structural protein associated with the muscle sarcolemma (17–19). Studies on the decay of myosin heavy chain and actin mRNAs (which also encode structural proteins in muscle) have shown them to be relatively stable, with half-lives of ~15 and 55 h, respectively (20). In contrast, the *c-myc* mRNA, which appears to be involved in the cellular response to mitogens, has a very short half-life of 15 to 30 min in myogenic cells (21). Therefore, the dystrophin mRNA appears to be a fairly stable transcript and has a half-life similar to the half-lives observed for mRNAs encoding other structural proteins in muscle.

During the course of our kinetic studies we developed a novel approach for estimating the dystrophin mRNA half-life in muscle tissue *in vivo*. The ratio of total (nascent plus mature) to mature dystrophin transcript is determined by the time required for transcription and the half-life of the mRNA when the system is at steady state (see detailed explanation in Appendix). Since we know the transcription time from measurements we made previously in cultured myogenic cells (1) we reasoned that the ratio of total to mature transcript could be used to estimate the dystrophin mRNA half-life in muscle tissue, assuming the tissue is at steady state. We obtained muscle from a human adult, measured the ratio of total to mature dystrophin transcript, and found the average ratio to be 2.9 ± 0.9 (Table 1) with the majority of values centered around 2.4. The expected ratio assuming a half-life of 15.6 ± 2.8 h was 1.5 (ranging from 1.4 to 1.6). Using the ratio of 2.9 ± 0.9 in equation 1 of the Appendix the half-life of the dystrophin mRNA is predicted to be 3.4 h with a minimum of 2 h and a maximum of 7 h (using the standard deviation) and is therefore less than the half-life obtained using myogenic cultures treated with actinomycin D.

Since we obtained different values for the half-life in our two systems and because actinomycin D can sometimes lead to inaccurate estimates of mRNA half-lives due to selective transcript stabilization we used a third approach to assess the half-life. An independent evaluation of the half-life in culture in the absence of actinomycin D can be obtained by comparing the

transcript accumulation curve we observed in our previous studies (1) with the accumulation profile predicted using a kinetic model that incorporates the measured half-life. In our previous report we monitored transcript accumulation at the 5'- and 3'-ends of the dystrophin gene following induction of expression in myogenic cultures. We observed an increase in transcript first near the 5'-end of the gene (exon 3) and then ~12 h later near the 3'-end of the gene (exon 69) (Fig. 5). This delay is explained by the time required for polymerase to traverse the 1770 kb between exons 3 and 69 (1). The shape of a transcript accumulation profile is determined by the rate of transcript synthesis (K_s) and the decay or half-life ($t_{1/2}$) of the mRNA. Using the kinetic model described in the legend to Figure 5 the transcript accumulation profile was predicted using half-lives of 15.6 and 3.4 h and these curves were then compared with the observed accumulation profile (Fig. 5). The modeled curve obtained using a half-life of 15.6 h is most consistent with the observed profile suggesting that the measured half-life obtained using cultures treated with actinomycin D is valid and is not due to selective stabilization of the transcript by actinomycin D. Therefore we have shown the half-life in culture to be 15.6 h using actinomycin D and obtained consistent results in the absence of actinomycin D by modeling the profile of transcript induction in these cultures. The similarity of the observed and predicted curves also suggests that other factors such as premature termination of transcription complexes are unlikely to contribute significantly to dystrophin transcript accumulation in cultured myogenic cells.

There are several possible reasons why an apparent excess of nascent transcript relative to mature (as indicated by the higher than expected ratio) was detected in adult muscle tissue. One possibility is that the dystrophin mRNA may turnover more rapidly in the adult tissue than in cultured fetal muscle. Alternatively, dystrophin gene expression may not be at steady state in human adult skeletal muscle tissue as would be the case if the muscle tested had been undergoing growth or regeneration. Finally, other explanations include significant levels of premature termination in adult skeletal muscle that do not occur in cultured fetal muscle, or the existence of another transcript in adult muscle tissue that includes exon 3 but not exon 69. Experiments to identify local alternative splicing indicate that neither of these exons are alternatively spliced in muscle tissue (22,23).

In summary our studies using actinomycin D have shown that the dystrophin transcript, which requires 16 h to be transcribed, has a half-life of 15.6 ± 2.8 h in myogenic cultures. This half-life is consistent with the nature of the transcript accumulation profile observed for the dystrophin gene under induction conditions in fetal myogenic cultures.

Dystrophin transcript levels in adult skeletal muscle tissue

Quantitative RT-PCR measurements of dystrophin transcript levels in human skeletal muscle tissue indicate that on average there are 781 molecules of mature dystrophin transcript per ng of total RNA (Table 1). Assuming a yield of 1 ng of RNA per 100 muscle nuclei [as obtained for cultured human myogenic cells and consistent with RNA yields obtained given 5×10^7 nuclei/g of wet muscle tissue (24,25)], this indicates 7.8 ± 2.7 molecules of dystrophin mRNA per nucleus in adult skeletal muscle. This result is consistent with other studies indicating the dystrophin transcript is expressed at low levels relative to other muscle transcripts (15) and is comparable with the level of transcript

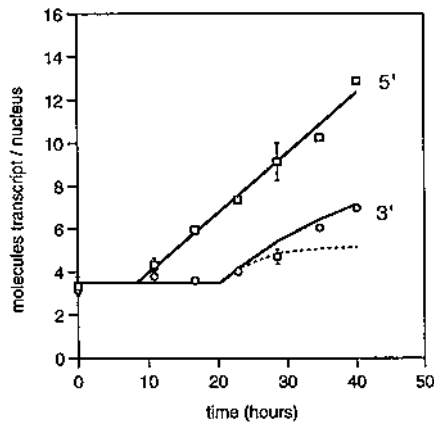

Figure 5. Observed and predicted transcript accumulation profiles for the dystrophin gene. Observed transcript accumulation profiles from our previous study (1) are shown for the 5' (exon 3) (□) and 3' (exon 69) (○) ends of the dystrophin gene following induction of expression in myogenic cultures. An increase in transcript is observed first at the 5'-end of the gene and then ~12 h later at the 3'-end. This delay reflects the time required for polymerase to traverse the 1770 kb between exons 3 and 69. The profile of transcript accumulation is dictated by the rates of synthesis and decay. The mathematical model most commonly used to predict accumulation profiles is represented by the equation $dM/dt = K_s - K_1 [M]$ (20,27) where $[M]$ is the concentration of mRNA (molecules/cell), K_s is the rate of synthesis (molecules/cell/h), and K_1 is the decay constant (h^{-1}). We used the solution to this equation $\{[M]_t = K_s/K_1 (1 - e^{-K_1 t})\}$ to determine the concentration of mRNA at a given time (t) where K_1 is related to the half-life ($t_{1/2}$) by the equation $K_1 = \ln 2/t_{1/2}$. During the early stages of induction the accumulation curve obtained for the 5'-end is dictated by the rate of synthesis of dystrophin transcript since during the first 12 h all of the transcript is nascent and therefore decay will have no impact. Therefore the 5' slope = $K_s = 0.26$ molecules/nucleus/h. Transcripts containing exon 69 begin to accumulate at 20.4 h and in this model we assumed a 90 min delay before mRNA decay begins to effect accumulation. This time is required for completion of exon 69-containing transcripts, processing of the transcript (1) and transport to the cytoplasm (26), events which must occur before the mRNA is exposed to the processes of decay. The predicted accumulation profiles for the 3'-end of the gene are shown assuming a half-life of 15.6 h (solid line) and 3.4 h (dashed line).

expressed in myogenic cultures (1). As a comparison the highly abundant muscle transcript encoding the myosin heavy chain is present at 25 000–50 000 copies per nucleus (20).

ACKNOWLEDGEMENTS

We thank C. L. Duff for preparation of the human myogenic clones. This research was supported by grants from the Medical Research Council of Canada and the Canadian Genetic Diseases Network. C. N. Tennyson was the recipient of a postgraduate scholarship from the Natural Sciences and Engineering Research Council of Canada.

REFERENCES

- Tennyson, C.N., Klamut, H.J. and Worton, R.G. (1995) *Nature Genet.*, **9**, 184–190.
- Roberts, R.G., Coffey, A.J., Bobrow, M. and Bentley, D.R. (1993) *Genomics*, **16**, 536–538.
- Coffey, A.J., Roberts, R.G., Green, E.R., Cole, C.G., Butler, R., Anand, R., Gianelli, F. and Bentley, D.R. (1992) *Genomics*, **12**, 474–484.
- Monaco, A., Walker, A.P., Millwood, I., Larin, Z. and Lehrach, H. (1992) *Genomics*, **12**, 465–473.
- Shaw, G. and Kamen, R. (1986) *Cell*, **46**, 659–667.
- Volloch, V. and Housman, D. (1981) *Cell*, **23**, 509–514.

- Wilson, T. and Treisman, R. (1988) *Nature*, **336**, 396–399.
- Sachs, A.B. (1993) *Cell*, **74**, 413–421.
- Klamut, H.J., Zubrzycka-Gaarn, E.E., Bulman, D.E., Malholtra, S.B., Bodrug, S.E., Worton, R.G. and Ray, P.N. (1989), **45**, 681–702.
- Chomczynski, P. and Sacchi, N. (1987) *Anal. Biochem.*, **162**, 156–159.
- Sambrook, J., Fritsch, E.F. and Maniatis, T. (1989) *Molecular Cloning: A Laboratory Manual*. 2nd Ed., Cold Spring Harbor Laboratory, Cold Spring Harbor, NY.
- Wang, A.M., Doyle, M.V. and Mark, D.F. (1989) *Proc. Natl. Acad. Sci. USA*, **86**, 9717–9721.
- Nudel, U., Robzyk, K. and Yaffe, D. (1988) *Nature*, **331**, 635–638.
- Lederfein, D., Yaffe, D. and Nudel, U. (1993) *Hum. Mol. Genet.*, **2**, 1883–1888.
- Chelly, J., Kaplan, J., Maire, P., Gautron, S. and Kahn, A. (1988) *Nature*, **333**, 858–860.
- Chelly, J., Montarras, D., Pinset, C., Berwald-Netter, Y., Kaplan, J.C. and Kahn, A. (1990) *Eur. J. Biochem.*, **187**, 691–698.
- Campbell, K.P. and Kahl, S.D. (1989) *Nature*, **338**, 259–262.
- Koenig, M., Monaco, A.P. and Kunkel, L.M. (1988) *Cell*, **53**, 219–228.
- Zubrzycka-Gaarn, E.E., Bulman, D.E., Karpati, G., Burghes, A.H.M., Belfall, B., Klamut, H.J., Talbot, J., Hodges, R.S., Ray, P.N. and Worton, R.G. (1988) *Nature*, **333**, 466–469.
- Medford, R.M., Nguyen, H.T. and Nadal-Ginard, B. (1983) *J. Biol. Chem.*, **258**, 11063–11073.
- Wisdom, R. and Lee, W. (1990) *J. Biol. Chem.*, **265**, 19015–19021.
- Bies, R.D. (1992) *Nucleic Acids Res.*, **20**, 1725–1731.
- Feener, C.A., Koenig, M. and Kunkel, L.M. (1989) *Nature*, **338**, 509–511.
- Gibson, M.C. and Schultz, E. (1983) *Muscle and Nerve*, **6**, 574–580.
- Hahn, C. and Covault, J. (1990) *Anal. Biochem.*, **190**, 193–197.
- Nevins, J.R. and Darnell, J.E. (1978) *Cell*, **15**, 1477–1493.
- Hargrove, J.L. and Schmidt, F.H. (1989) *FASEB*, **3**, 2360–2370.

APPENDIX

Ratio of total to mature dystrophin transcript at steady state

At steady state, the ratio of total (nascent plus mature) transcript to mature can be predicted using the following equation;

$$\frac{5'}{3'} = \frac{\text{nascent} + \text{mature}}{\text{mature}} = \frac{R_i T_t + R_m t_{1t}}{R_m T_{1t}}$$

where R_i is the rate of transcription initiation, R_m is the rate of formation of mature transcript, T_t is the transcription time, and T_{1t} is the mean lifetime of the mature transcript. If $R_i = R_m$, that is the rate of initiation and the rate of formation of mature transcript are the same (i.e. no premature termination of transcription complexes) then the equation can be simplified.

$$\frac{5'}{3'} = \frac{\text{nascent} + \text{mature}}{\text{mature}} = \frac{T_t + T_{1t}}{t_{1t}}$$

This equation simply reflects that transcripts monitored at the 5'-end will on average survive the time required for transcription plus the mean lifetime of the mature transcript while transcripts monitored at the 3'-end will survive the mean lifetime.

In the case of the dystrophin gene, we have shown previously that it takes ~12 h to transcribe from exon 3 to exon 69 (1). We estimate that an additional 1–2 h (we use 90 min in the calculation) are required to complete transcription, and to process and transport the mRNA to the cytoplasm (1,26). The mean lifetime (T_{1t}) is related to the half-life ($t_{1/2}$) by the equation $T_{1t} = t_{1/2}/0.693$ (27). Thus, the ratio of total to mature dystrophin transcript may be written as shown below.

$$\frac{5'(\text{exon}3)}{3'(\text{exon}69)} = \frac{(12 \text{ h}) + (90 \text{ min} + t_{1/2}/0.693)}{(90 \text{ min} + t_{1/2}/0.693)}$$