

# Synthesis of full-length oligonucleotides: cleavage of apurinic molecules on a novel support

Marek Kwiatkowski\*, Mats Nilsson and Ulf Landegren

The Beijer Laboratory, Department of Medical Genetics, Uppsala University, S-751 23 Uppsala, Sweden

Received September 5, 1996; Revised and Accepted October 14, 1996

## ABSTRACT

The synthesis of oligodeoxynucleotides is marred by several problems that contribute to the formation of defective molecules. This in turn seriously limits the usefulness of such reagents in DNA diagnostics, molecular cloning, DNA structural analysis and in antisense therapy. In particular, depurination reactions during the cyclical steps of synthesis lead to strand scission during cleavage of the completed molecules from the support. Here we present a remedy to this problem: a novel disiloxy linkage that connects oligonucleotides to the support withstands reaction conditions that allow the removal of the 5' parts of any depurinated molecules. This ensures that all molecules that preserve the 5' protecting group when cleaved from the support will have both correct 3'- and 5'-ends. We demonstrate the application of the support for synthesis of padlock probe molecules.

## INTRODUCTION

In the course of a project to detect specific nucleotide sequences using padlock probes (1), that is linear oligonucleotides that can be specifically ligated into circles that remain bound to their target sequence, we were confronted with the difficulty of synthesizing full-length oligodeoxynucleotides. The ligation-based test is sensitive to the presence of shorter oligonucleotide fragments that compete for target sequences but cannot be ligated. The problem of oligonucleotide purity is, however, a general one as exemplified by the requirement for high quality products in molecular cloning (2,3), diagnostic applications, in physicochemical and structural DNA studies (4), and in antisense therapy (5).

The production of defective oligonucleotides has two prominent causes: (i) depurination reactions that take place during the synthetic cycles are followed by strand scission during deprotection; and (ii) premature termination of synthesis, followed by capping, results in 5' truncated molecules. Preparative gel electrophoresis provides the best resolution for purification of oligonucleotides. The method is laborious, however, often leading to considerable loss of material, and it is poorly suited for automation and scale-up. By contrast, chromatographic separation offers a potential for efficient automated purification. The limited resolving power of chromatographic systems has been addressed by using

affinity tags. The commonly used trityl-on oligonucleotide separation on reversed-phase columns offers the possibility to isolate fragments with intact 5'-ends. However, the 5' part of depurinated and cleaved molecules notoriously contaminate oligonucleotides purified by this method.

A mild basic system has been proposed for partial deprotection and cleavage of apurinic sites with the oligonucleotides still bound to the solid support. In this manner the 5'-ends of depurinated molecules can be discarded before the oligonucleotides are released from the support, followed by isolation of molecules with intact 5'-ends (6). In practise, this strategy was accompanied by a substantial loss of products, due to inadvertent release of oligonucleotides from the support during cleavage of depurinated sites. It is desirable to have a linkage function far more stable than the standard ester under the conditions required to cleave abasic sites. Such functions have been described but they have either proven too stable (7,8), or they yield 3'-phosphorylated oligonucleotides (9,10).

Holmberg has proposed the use of a siloxy group as a linker in oligonucleotide synthesis (11), as this linkage is inert during the synthetic cycles and resists conditions that cleave apurinic sites. This linker is finally cleaved with tetrabutylammonium fluoride (TBAF) to obtain, after reversed-phase isolation of dimethoxytrityl-(DMTr-) containing material, an oligonucleotide with both 3'- and 5'-ends intact. Synthesis of this support was laborious and inconvenient. Moreover, the nucleoside loadings on the support were consistently low.

Here we have applied a commercially available 1,3-dichloro-1,1,3,3-tetra-isopropyl disiloxane to improve the above methodology by introducing a disiloxy group as a stable linker function. We demonstrate that synthesis on these supports yields oligonucleotides of dramatically increased purity, and with intact 5'- and 3'-ends.

## MATERIALS AND METHODS

### Reagents

All commercial chemicals were of synthesis quality and they were used without further purification. 1,3-Dichloro-1,1,3,3-tetra-isopropyl disiloxane was synthesized according to Markiewicz (12), 2-cyanoethyl-*N,N*-diisopropylamino phosphochloridite according to Sinha *et al.* (13), and the phosphorylating reagent containing TrS moiety, 3-triphenylmethylmercaptoethoxy 2-

\*To whom correspondence should be addressed. Tel: +46 18 508 760; Fax: +46 18 526 849; Email: marek.kwiatkowski@medgen.uu.se

cianoethoxy *N,N*-diisopropylaminophosphine according to Connolly (14). Controlled-pore glass (CPG; 1000 Å; CPG Inc., Fairfield) was aminopropylsilylated according to Pon *et al.* (15).

Dry pyridine was obtained from Merck, triethylamine was dried over solid KOH, followed by distillation, discarding the first and last 10% of the distillate.

### Analytic and preparative methods

Proton nuclear magnetic resonance (NMR) spectra were recorded on a Joel JNM-FX200 spectrometer at 200 MHz using TMS as an internal standard. Phosphorus NMR spectra were recorded in a Varian Unity 500 operating at 202 MHz relative to 70% phosphoric acid as an external standard.

Thin-layer chromatography (TLC) was run on glass silica gel plates (Kieselgel 60 F<sub>254</sub>, Merck) using the following solvent systems: system A, methanol in chloroform (1:19 v/v); system B, methanol in chloroform (1:9 v/v); system C, n-hexane:CH<sub>2</sub>Cl<sub>2</sub>:triethylamine (45:45:10 v/v).

Preparative silica gel flash chromatography was performed using Kieselgel 60 (Merck, art 9385).

Oligonucleotide syntheses were performed either on an ABI 394 DNA Synthesizer or a Gene Assembler Plus (Pharmacia) instrument. Analytical liquid chromatography of oligonucleotides was performed on a Hitachi-Merck La Chrom HPLC system, equipped with a LiChrospher RP 18 (5 μm) column and using a linear gradient of solvent A:acetonitrile 5% v/v in 0.1 M triethylammonium acetate, pH 7.0, and solvent B:acetonitrile 40% v/v in 0.1 M triethylammonium acetate, pH 7.0. Preparative separations were made on an FPLC system (Pharmacia) using a reversed-phase Pep RPC 10/10 column and the above solvent gradient.

Oligonucleotides to be analyzed by electrophoresis were 5' labelled with <sup>32</sup>P, using polynucleotide kinase in a 50 μl reaction volume of 50 mM KAc, 10 mM MgAc<sub>2</sub>, 10 mM Tris-HAc (pH 7.5), 10 μCi [<sup>γ</sup>-<sup>32</sup>P]ATP (3000 Ci/mmol) and 20 U polynucleotide kinase (Amersham) at 37°C for 30 min. The labelling reaction was stopped by desalting on a Sephadex G-50 spin column, followed by incubation at 65°C for 5 min. All oligonucleotides analyzed by electrophoresis in this study were synthesized with a 5' phosphate to ensure that cleaved apurinic oligonucleotides, having 5'-phosphate groups, would label with the same efficiency as the full-length molecules through a phosphate exchange reaction. After separation on a denaturing 6% polyacrylamide gel the radioactivity was recorded by autoradiography (Amersham Hyperfilm) or scanned on a PhosphorImager instrument (Molecular Dynamics) for quantitative measurement of band intensities.

### Synthesis of nucleosides with 3' cleavable linkers

5'-*O*-(4,4'-dimethoxy)trityl thymidylyl 3'-*O*-(1,1,3,3-tetraisopropyl-disiloxyl-3)-(1-*O*-3,6,9-trioxa)undecan-11-ol (6) (*B*=*T*). 5'-DMTr-thymidine (1) (1.30 g, 2.3 mmol) and imidazol (0.32 g, 4.8 mmol) were dried by coevaporation with dry pyridine and dissolved in 20 ml dry pyridine. 1,3-Dichloro-1,1,3,3-tetraisopropyl disiloxane (2) (0.75 g, 2.4 mmol) was added and the mixture was stirred at 20°C for 3 h to achieve complete consumption of the starting material. Tetraethylene glycol (3.9 g, 23 mmol) was added to the formed compound (3) and the mixture was stirred for 6 h. Pure compound (6) was isolated as an oil (1.62 g, 72%), *R*<sub>f</sub> = 0.52 (system A), following standard bicarbonate work-up, extraction with CH<sub>2</sub>Cl<sub>2</sub>, evaporation of the organic phase and

flash column chromatography. <sup>1</sup>H-NMR (CDCl<sub>3</sub>): 0.85–1.05 (m, 28 H), 1.43 (s, 3 H), 2.25–2.42 (m, 2 H), 2.85 (s, broad, 1 H), 3.27–3.52 (dd, 2 H), 3.54–3.76 (m, 12 H), 3.79 (s, 3 H), 3.80–3.85 (m, 2 H), 4.09 (m, 1 H), 4.68 (m, 1 H), 6.40 (t, 1 H), 6.83 (d, 4 H), 7.23–7.40 (m, 9 H), 7.63 (d, 1 H), 9.19 (s, broad, 1 H).

The next three nucleoside derivatives were obtained in a similar manner.

*N*<sup>4</sup>-Benzoyl-5'-*O*-(4,4'-dimethoxy)trityl 2'-deoxycytidylyl 3'-*O*-(1,1,3,3-tetraisopropyl-disiloxyl-3)-(1-*O*-3,6,9-trioxa)undecan-11-ol (6) (*B*=*C*<sup>Bz</sup>). Oil, yield 69%, *R*<sub>f</sub> = 0.55 (system A), <sup>1</sup>H-NMR (CDCl<sub>3</sub>): 0.82–1.17 (m, 28 H), 2.12–2.75 (m, 2 H), 3.28–3.55 (dd, 2 H), 3.58–3.76 (m, 14 H), 3.82 (s, 3 H), 3.83–3.92 (m, 2 H), 4.17 (m, 1 H), 4.66 (m, 1 H), 6.30 (t, 1 H), 6.85 (d, 4 H), 7.16–7.43 (m, 10 H), 7.50 (d, 2 H), 7.59 (d, 1 H), 7.91 (d, 2 H), 8.30 (d, 1 H).

*N*<sup>6</sup>-Benzoyl-5'-*O*-(4,4'-dimethoxy)trityl 2'-deoxyadenylyl 3'-*O*-(1,1,3,3-tetraisopropyl-disiloxyl-3)-(1-*O*-3,6,9-trioxa)undecan-11-ol (6) (*B*=*A*<sup>Bz</sup>). Oil, yield 78%, *R*<sub>f</sub> = 0.61 (system A), <sup>1</sup>H-NMR (CDCl<sub>3</sub>): 0.83–1.26 (m, 28 H), 2.45–3.05 (m, 2 H), 3.20–3.45 (dd, 2 H), 3.50–3.75 (m, 14 H), 3.77 (s, 3 H), 3.81–3.90 (m, 2 H), 4.28 (m, 1 H), 4.82 (m, 1 H), 6.52 (t, 1 H), 6.79 (d, 4 H), 7.14–7.60 (m, 14 H), 8.12 (s, 1 H), 8.72 (s, 1 H), 9.86 (s, broad, 1 H).

*N*<sup>2</sup>-Benzoyl-5'-*O*-(4,4'-dimethoxy)trityl 2'-deoxyguanylyl 3'-*O*-(1,1,3,3-tetraisopropyl-disiloxyl-3)-(1-*O*-3,6,9-trioxa)undecan-11-ol (6) (*B*=*G*<sup>Bz</sup>). Oil, yield 64%, *R*<sub>f</sub> = 0.47 (system A), <sup>1</sup>H-NMR (CDCl<sub>3</sub>): 0.80–1.10 (m, 28 H), 2.39–2.95 (m, 2 H), 3.12–3.45 (dd, 2 H), 3.53–3.93 (m, 12 H), 3.65 (s, 3 H), 3.70 (s, 3 H), 4.17 (m, 1 H), 4.75 (m, 1 H), 6.24 (dd, 1 H), 6.75 (d, 4 H), 7.12–7.52 (m, 14 H), 7.83 (s, 1 H), 8.81 (s, broad, 1 H).

### Conversion of the nucleosides to phosphoramidites

5'-*O*-(4,4'-Dimethoxy)trityl thymidylyl 3'-*O*-(1,1,3,3-tetraisopropyl-disiloxyl-3)-(1-*O*-3,6,9-trioxa)undecan-11-ol-(2-cyanoethoxy)-(N,N-diisopropylamino)phosphine (7) (*B*=*T*). The thymidine derivative (6) (1.50 g, 1.53 mmol) was dried by coevaporation with toluene (20 ml) and dissolved in anhydrous CH<sub>2</sub>Cl<sub>2</sub> (15 ml). To this magnetically stirred solution dry triethylamine (0.85 ml, 6.0 mmol) was added, followed by 2-cyanoethyl-*N,N*-diisopropylaminophosphochloridate (710 mg, 3.0 mmol). After 15 min stirring at 20°C, TLC (system C) showed consumption of all starting material and formation of a single product. The reaction mixture was quickly partitioned between saturated aqueous sodium bicarbonate and CH<sub>2</sub>Cl<sub>2</sub>, and extracted with CH<sub>2</sub>Cl<sub>2</sub> (2 × 50 ml). The residue obtained after evaporation of the organic phase was dried by coevaporation with toluene and purified on a short silica gel column, prepared and eluted with CH<sub>2</sub>Cl<sub>2</sub>:triethylamine 9:1 v/v. Fractions containing the desired product were combined, evaporated *in vacuo*, coevaporated with dry triethylamine, and dried in high vacuum to yield 1.57 g (87%) of an oil: *R*<sub>f</sub> = 0.78 (system C); <sup>31</sup>P-NMR (CDCl<sub>3</sub> + 2 drops of triethylamine) 148.61 p.p.m.

The remaining amidites were prepared in a similar way.

*N*<sup>4</sup>-Benzoyl-5'-*O*-(4,4'-dimethoxy)trityl 2'-deoxycytidylyl 3'-*O*-(1,1,3,3-tetraisopropyl-disiloxyl-3)-(1-*O*-3,6,9-trioxa)undecan-11-ol-(2-cyanoethoxy)-(N,N-diisopropylamino)phosphine (7) (*B*=*C*<sup>Bz</sup>). Yield (93%) of an oil: *R*<sub>f</sub> = 0.75 (system C); <sup>31</sup>P-NMR (CDCl<sub>3</sub> + 2 drops of triethylamine) 148.59 p.p.m.

*N*<sup>6</sup>-Benzoyl-5'-*O*-(4,4'-dimethoxy)trityl 2'-deoxyadenylyl 3'-*O*-(1,1,3,3-tetraisopropyl-disiloxyl-3)-(1-*O*-3,6,9-trioxa)undecan-

*11-oxy*)-(2-cyanoethoxy)-(N,N-diisopropylamino)phosphine (7) ( $B=A^{Bz}$ ). Yield (73%) of an oil:  $R_f = 0.82$  (system C);  $^{31}\text{P-NMR}$  ( $\text{CDCl}_3 + 2$  drops of triethylamine) 148.54 p.p.m.

*N*<sup>2</sup>-Benzoyl-5'-*O*-(4,4'-dimethoxy)trityl 2'-deoxyguanylyl 3'-*O*-(1,1,3,3-tetraisopropyl-disiloxy-3)-(1-*O*-3,6,9-trioxaundecan-11-oxy)-(2-cyanoethoxy)-(N,N-diisopropylamino)phosphine (7) ( $B=G^{Bz}$ ). Yield (80%) of an oil:  $R_f = 0.68$  (system C);  $^{31}\text{P-NMR}$  ( $\text{CDCl}_3 + 2$  drops of triethylamine) 148.56 p.p.m.

### Synthesis of reagents for derivatization of CPG supports

*Ethyl-6-(3-hydroxypropionamido)hexanoate* (10). 6-Amino-hexanoic acid (8) (13.1 g, 0.1 mol) was magnetically stirred with ethanol (99.5%, 250 ml) at 20°C. Thionyl chloride (3 ml, 41 mmol) was carefully added and the mixture was stirred for 16 h. The residue obtained after evaporation of all volatile matters was coevaporated with toluene (2 × 50 ml) to remove all traces of free HCl, and dissolved in dry ethanol (30 ml). Triethylamine (28 ml, 0.2 mol) and  $\gamma$ -butyrolacton (17 ml, 0.2 mol) were added and the mixture was refluxed for 16 h. The cooled solution was evaporated, then coevaporated with toluene, and the residual oil was flash chromatographed to yield pure hydroxyester (10) (17.5 g, 71%). This ninhydrin-negative material with  $R_f = 0.39$  (system B) was visualized after spraying with a dilute solution of permanganate.  $^1\text{H-NMR}$  ( $\text{CDCl}_3$ ): 1.24 (t, 3 H), 1.35–1.99 (m, 8 H), 2.13–2.44 (m, 4 H), 3.07–3.29 (q, 2 H), 3.58 (t, 2 H), 4.10 (q, 2 H), 6.49 (t, broad, 1 H).

*Triethylammonium 6-(3-*O*-dimethoxytritylpropionamido)hexanoate* (12). The hydroxyester (10) (1.8 g, 7.3 mmol) was coevaporated with dry pyridine (20 ml) and dissolved in pyridine (20 ml). Dimethoxytrityl chloride (2.5 g, 7.3 mmol) was added and the mixture was stirred magnetically until TLC analysis demonstrated that the starting material had disappeared (4 h). Ester (11) ( $R_f = 0.76$  in system B) was hydrolyzed upon addition of methanol (10 ml), triethylamine (2 ml), and sodium hydroxide solution (2 M, 21 ml, 42 mmol) to form the salt of (12) with  $R_f = 0.16$  in the same TLC system. After standard work-up and flash column chromatography the pure triethylammonium salt of (12) was isolated in the form of a yellowish solid (0.94 g, 84%).  $^1\text{H-NMR}$  ( $\text{CDCl}_3$ ): 1.21 (t, 9 H), 1.22–1.43 (m, 4 H), 1.60 (m, 2 H), 1.91 (m, 2 H), 2.22–2.33 (m, 4 H), 3.01 (q, 6 H), 3.05–3.18 (m, 4 H), 3.78 (s, 6 H), 5.68 (t, 1 H), 6.82 (d, 4 H), 7.16–7.45 (m, 9 H).

### Construction of a hydroxyalkyl-derivatized CPG support (14)

Compound (12) (0.62 g, 1.0 mmol) was dried by coevaporation with dry acetonitrile and dissolved in dry tetrahydrofuran (9 ml) and diisopropylethylamine (0.5 ml). To this stirred solution isobutyl chloroformate (165  $\mu\text{l}$ , 1.0 mmol) was added and the mixture was stirred for 1 h at 20°C. Different volumes of this solution, containing anhydride (13), were withdrawn and added to the aminopropyl-CPG (500 mg), previously coevaporated with toluene and suspended in the mixture of dry tetrahydrofuran (3 ml) and diisopropylethylamine (0.1 ml). Derivatization of supports proceeded for 30 min with occasional shaking. The residual amino functions were capped by addition of acetic anhydride (1 ml) and 4-(dimethylamino)pyridine (50 mg) in pyridine (5 ml). After 2 h incubation, supports were washed on a filter with pyridine, methanol and diethyl ether. The substitution

level was analyzed based on DMTr-cation release as described by Gait *et al.* (16). CPG (14) derivatized to the extent of 28  $\mu\text{mol/g}$  was selected for further experiments. This support could be used for direct derivatization with phosphoramidite (7), carrying the cleavable disiloxy moiety.

Recently, attention has been directed at the appearance of slightly shorter products, so called  $n - 1$  and  $n - 2$  fragments, during oligonucleotide synthesis (17,18). Since most of the so-called  $n - 1$  products have been reported to occur during the first five cycles of synthesis, we introduced the cleavable function only after the incorporation of 10 residues of thymidilic acid on the supports. Several DNA synthesis columns were loaded with support (14) (~10 mg each), and they were subjected to 10 coupling cycles with a thymidine amidite, followed by coupling of one of the nucleoside amidites (7). Supports (16) prepared in this manner were used in most oligonucleotide syntheses. However, by direct comparison between oligonucleotides synthesized on supports with and without the ten thymidilic acid linker, no difference in the appearance of  $n - 1$  sequences was observed (data not shown).

### Solid-phase synthesis of oligonucleotides

The CPG support (16) described above was used for oligonucleotide synthesis. All couplings were performed using amidites protected by benzoyl (dA, dC) and isobutyryl (dG) groups at the exocyclic amine functions, under conditions recommended by the manufacturer for 0.2  $\mu\text{mol}$  scale synthesis. The final trityl groups were left on the synthesized oligonucleotides (17) to aid in subsequent separations.

### Deprotection and purification of oligonucleotides

A syringe filled with a mixture of triethylamine:ethanol, 1:1 v/v, was connected to the column. Treatment of the support with base proceeded for 3 h at 20°C, with the occasional addition of a new aliquot of the solvent to the column. The column was washed with ethanol (2 ml) and water (2 × 2 ml), dried with acetonitrile (3 × 2 ml), and after opening the cassette the solid support was transferred to a Sarstedt screw-lock tube. TBAF 0.5 M in dry THF (200  $\mu\text{l}$ ) was added and the mixture was incubated for 4 h at 20°C. Alternatively, the disiloxy linker could be cleaved using 200  $\mu\text{l}$  0.5 M TBAF in dry DMF at 65°C for 30 min. To this mixture concentrated aq.  $\text{NH}_3$  (2 ml) was added and the mixture was placed in a 65°C oven for 12 h. After partial concentration the oligonucleotides were desalted on a NAP 10 Sephadex column and analyzed by HPLC on an RP 18 column. Preparative runs were done on an FPLC system using a reversed-phase Pep RPC column. Rather than fractionating the hydrophobic trityl-containing product, the whole peak was collected to simulate bulk separation on disposable RP cartridges. After evaporation, DMTr groups were finally removed using 80% aq. acetic acid for 20 min at 20°C, with subsequent evaporation of the acid. Oligonucleotides phosphorylated at their 5' position by the Tr-S phosphorylating reagent were finally deprotected according to a published procedure (14).

### Circularization of oligonucleotides

A 91mer oligonucleotide (M13C91; 5'-pGCCTGCAGGTC-GACTCTAGA(T)<sub>50</sub>CGGCCAGTGCCAAGCTTGCA-3') was synthesized to use as a padlock probe, that is to circularize in the



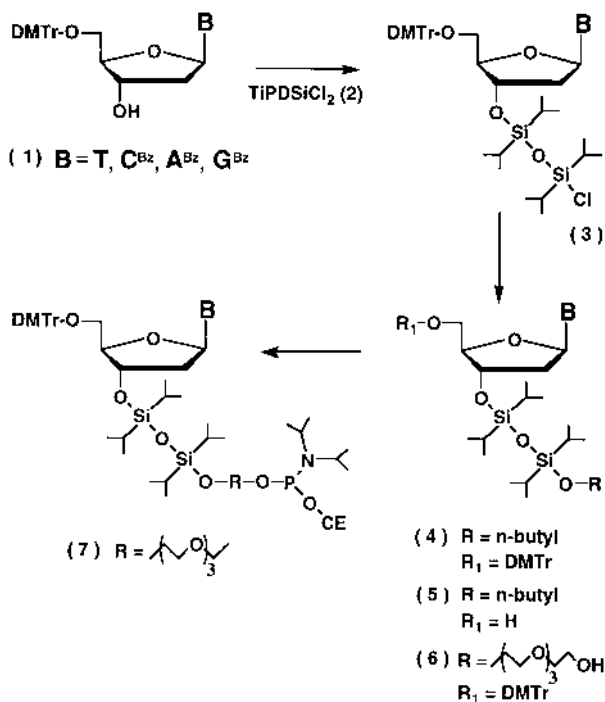

Scheme 1. Synthesis of monomeric building blocks.

presence of a DNA ligase and an oligonucleotide template, complementary to its two ends (M1350comp; 5'-TTTTTCTA-GAGTCGACCTGCAGGCATGCAAGCTTGGCACTGGCCGT-TTTT-3'). The ligation reaction was performed using 0.3 pmol of 5'-labelled probe and 5.5 pmol of template in a volume of 10  $\mu\text{l}$  20 mM Tris-HCl (pH 8.3), 25 mM KCl, 10 mM MgCl<sub>2</sub>, 1 mM NAD, 0.01% Triton X-100, and 10 U *Tth* DNA ligase (kindly provided by Dr Francis Barany). The samples were subjected to one, two or three cycles of 94°C for 15 s and 55°C for 10 min. The reactions were cooled on ice and stopped by adding 10  $\mu\text{l}$  loading buffer containing 50% formamide and 10 mM EDTA, followed by incubation at 65°C for 10 min. The reactions were analyzed on a denaturing polyacrylamide gel.

## RESULTS

### Synthesis of reagents

The readily available homobifunctional reagent 1,3-dichloro-1,1,3,3-tetraisopropyl disiloxane (2) has found broad applications for the selective protection of ribonucleoside hydroxyl groups. In this work, we have applied nucleosides (3), derivatized at their 3' position with this reagent to provide a base-stable linker function between a nucleoside and a solid support. The linker-containing phosphoramidite (7) was synthesized in a three-step reaction (Scheme 1). Silylation of appropriately protected nucleosides (1) was performed using only a slight excess of the reagent (2), in order to avoid the requirement to isolate intermediate (3). All reactions proceeded cleanly, despite the theoretical possibility of formation of a symmetrical disiloxy-3',3'-bis nucleoside as a side-product. The addition of an excess of an 13 atoms-long chain diol (tetraethyleneglycol) resulted in the formation of an asymmetrical disiloxy-derivative (6), used subsequently for the synthesis of phosphoramidite (7).

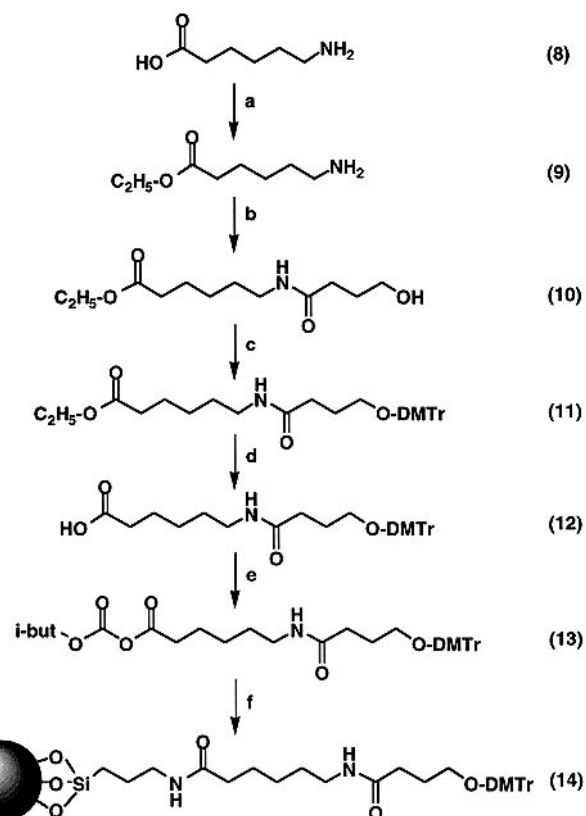
Scheme 2. Functionalization of CPG support. (a) thionyl chloride, ethanol, (b)  $\gamma$ -butyrolactone, (c) DMTrCl, (d) OH<sup>-</sup>, (e) isobutyl chloroformate, *N,N*-diisopropylethylamine, (f) aminopropylated CPG.

### Solid supports

Our strategy required a support functionalized with hydroxyl groups that are linked to the support through non-hydrolyzable bonds. Derivatization of CPG proceeded according to Scheme 2. Since no silanizing reagent for direct introduction of hydroxyalkyl functions was readily available, the CPG was activated starting by conventional aminopropylsilylation. Prior to further derivatization, the amino CPG support was treated with trichloroacetic acid in CH<sub>2</sub>Cl<sub>2</sub> according to Pon *et al.* (15) to avoid coupling yields in excess of 100%, otherwise frequently observed early in oligonucleotide synthesis. Compound (12) was prepared in high yield starting from the inexpensive 6-aminohexanoic acid and  $\gamma$ -butyrolactone. It was conveniently converted to the mixed anhydride (13) in a reaction with isobutyl chloroformate, and immediately used for coupling to CPG. By adding different amounts of (13) to solid supports, loadings ranging from 15 to 60  $\mu\text{mol/g}$  were obtained and a support (14) with 28  $\mu\text{mol/g}$  was selected for further experiments. The derivatized support was exhaustively capped with acetic anhydride and silanized with trimethylsilyl chloride (TMSCl).

### Stability of the disiloxy linker

In order to investigate the stability of the disiloxy bond under conditions of chemical oligonucleotide synthesis, the model compound (5) was synthesized in a one-pot reaction between

5'-protected thymidine and a slight excess of the reagent (2) (Scheme 1). The intermediate (3) formed in this reaction was further reacted with the next hydroxyl block, *n*-butyl alcohol, to give compound (4). After removal of the DMTr group, (5) was formed in 86% overall yield. This model compound was found to be quite stable to acids, giving less than 5% of decomposition products with 1% trichloroacetic acid in CH<sub>2</sub>Cl<sub>2</sub> during 36 h at room temperature. Treatment with 3% dichloroacetic acid in dichloroethane for 36 h gave a similar result. The subsequent stability studies revealed full compatibility of the nucleoside 3'-disiloxyl linkage with all reagents used in oligonucleotide synthesis. In particular, the new linkage proved stable to the alkaline conditions used in oligonucleotide deprotection. Due to the limited solubility of (5) in conc. aq. ammonia, these studies were performed in a 1:1 mixture of dioxan:conc. aq. ammonia. No degradation products were detected after treatment at room temperature for 24 h, and only 1–2% of thymidine was found after 6 h when the incubation was done at 65°C.

Silica-particles have limited stability under alkaline conditions. It was therefore necessary to find conditions to cleave apurinic sites without concomitant destruction of CPG. In analogy with a previously described experiment (6), a CPG-bound oligonucleotide (17, 5' T<sub>20</sub>AT<sub>15</sub>) was synthesized and depurinated, and the cleavage of the oligonucleotide at the apurinic site was studied using the following reaction conditions: (i) 1 M lysine, pH 10.0 at 60°C (6); (ii) conc. aq. ammonia:ethanol 1:3 v/v at 20°C; (iii) methanolic half-sat. ammonia at 20°C; (iv) triethylamine:ethanol 1:1 v/v at 20°C; (v) diisopropylamine:ethanol 1:1 v/v at 20°C; and (vi) piperidine:ethanol 1:1 v/v at 20°C. Among the investigated procedures, triethylamine:ethanol proved superior in cleaving depurinated sites without destroying the support. We conclude that a 3 h treatment at 20°C with this reagent suffices to cleave any depurinated sites with <10% loss of intact oligonucleotides.

### Synthesis of a purine-rich oligonucleotide

In order to examine the ability of the new procedure to eliminate depurinated sequences, an 81mer 5' p(AG)<sub>40</sub>T sequence was synthesized using either standard CPG or the novel CPG-based support (16), where a disiloxyl function was incorporated after the initial addition of 10 T residues. The synthesized oligonucleotides were deprotected manually (Fig. 1).

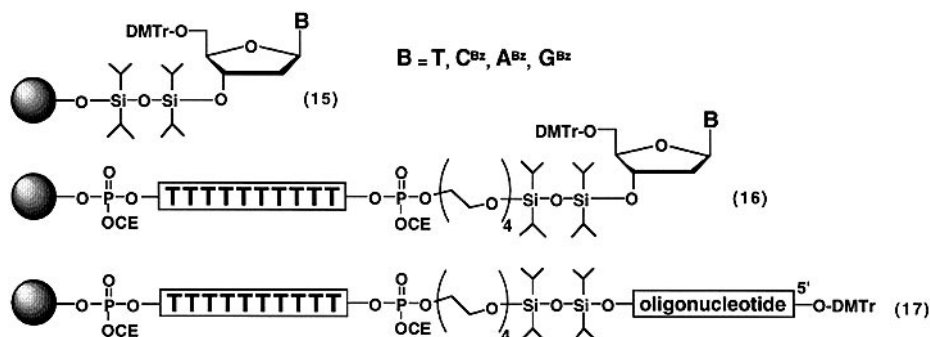

**Figure 1.** Supports for oligonucleotide synthesis: the structure at the top (15) illustrates functionalization suitable for polystyrene particles. The next two structures represent functionalization suitable for CPG particles, before (16) and after (17) oligonucleotide synthesis.

Partially deprotected, 5' TrS-substituted oligonucleotides were analyzed and isolated by HPLC. Products from both supports were detritylated, 5' <sup>32</sup>P-labelled, and separated by electrophoresis in a denaturing polyacrylamide gel. The results, presented in Figure 2 clearly show the superiority of the new method over the traditional one. This superiority was already evident by comparing the HPLC tracings (Fig. 2A). The considerably broader peak obtained in standard synthesis reflects the presence of many shorter and therefore more hydrophobic tritylated fragments. By contrast, the products synthesized according to the present method are practically free of 5'- and 3'-truncated sequences (Fig. 2B–D).

### Padlock probes

Padlock probes are linear oligonucleotides, the two ends of which can hybridize in juxtaposition on a target sequence and be joined through enzymatic ligation. This highly specific reaction circularizes the probes, linking them to target sequences. In this manner the probes provide sensitive and specific detection of localized target sequences (1). Typically padlock probes are ~90mer oligonucleotides. Any molecules lacking nucleotides at either end will occupy target sequences but without being able to contribute to the signal, as they cannot be ligated and are lost during washes, thus decreasing the signal. The template-dependent circularization of probe molecules thus serves as a sensitive measure for the integrity of both oligonucleotide ends.

We performed ligation reactions with a 91mer padlock probe and an excess of template oligonucleotides under conditions where all circularizable molecules should form circles. The results of the ligations were analyzed on a denaturing polyacrylamide gel (Fig. 3) and clearly show that all full-length oligonucleotides are ligatable as are most of the so-called *n* – 1 products, as expected if the missing nucleotides are distributed throughout the sequence. When overexposed, the autoradiogram also shows the presence of many still shorter products that can be ligated and thus must have intact 5'- and 3'-ends. These molecules therefore probably lack several contiguous internal nucleotides.

The gel reveals one class of products with an apparent size of *n* + 1 that will not ligate. These molecules also fail to act as primers for extension by terminaldeoxynucleotide transferase (data not shown). We therefore believe that they represent full-length products with a rest of the disiloxyl group at the 3'-end. These molecules are estimated to make up 3% of the purified

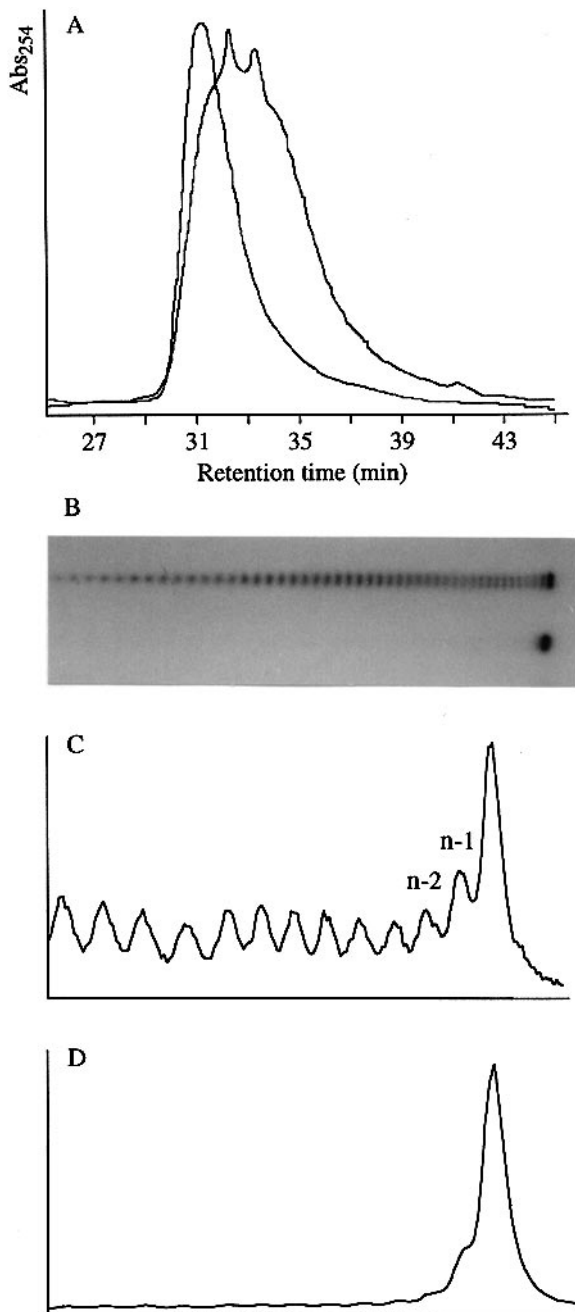

**Figure 2.** Synthesis of a purine rich 5' p(AG)<sub>40</sub>T oligonucleotide. (A) Reverse phase HPLC chromatogram showing the trityl-containing material. The products from a standard support appear as a much broader peak with a large proportion appearing later compared with the sharp and symmetrical peak from the novel support. (B) An autoradiogram showing material from a standard support at the top and from the novel support below. Products collected from the peaks in A were deprotected, 5' labelled and separated on a denaturing polyacrylamide gel. (C) Phosphorimager densitometry scan of the gel-separated material from the standard support, and (D) from the novel support.

padlock probes. While we never observed more than traces of such products in syntheses of shorter oligonucleotides, a gradual increase in frequency was observed with increasing length of the oligonucleotides.

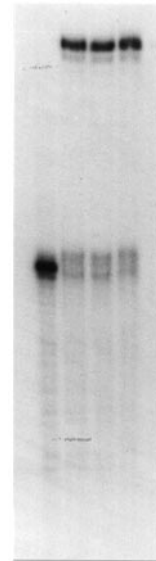

**Figure 3.** Circularization of a 91mer padlock probe. The oligonucleotides were <sup>32</sup>P-labelled at the 5'-end, and ligated using an excess of a complementary oligonucleotide as template. The reactions were performed using a thermostable ligase in several cycles of denaturation and ligation. Lane 1, no ligase; lanes 2, 3 and 4: 1, 2 and 3 cycles of ligation, respectively. All full length oligonucleotides were circularized during the first cycle of ligation.

We have successfully applied two padlock probes synthesized according to the present procedure in a fluorescent *in situ* hybridization study of centromeric sequences on human chromosomes 13 and 21, distinguished on the basis of a single nucleotide position (manuscript in preparation).

## DISCUSSION

We have demonstrated a support and method for the synthesis of oligonucleotides of superior quality. The procedure ensures that both ends of the isolated material are correct. It is particularly useful for the synthesis of long oligonucleotides, as these are susceptible to increased depurination and purification by HPLC or gel electrophoresis is difficult. We have applied the support for the synthesis of purine-rich oligonucleotides and padlock probes. The method was also found suitable for synthesis of oligonucleotides with strong intra- and intermolecular interactions. HPLC separation of such molecules under non-denaturing conditions often reveals several peaks, regardless of their purity (19). Since purification in our procedure is independent of the chromatographic profile, we could successfully isolate a pure 5' p(GGC)<sub>14</sub> oligonucleotide in good yield (data not shown).

The 3'-ends of oligonucleotides synthesized on supports constructed as described here are defined by the cleavable function. Therefore, syntheses initiated from illegitimate start sites on the support (20) can still contribute to the production of correct oligomers.

Large-scale synthesis of oligonucleotides often requires prolonged detritylation time and thereby increased risk of depurination. Chromatographic fractionation as a means to purify large amounts of oligonucleotides is expensive and unreliable. This support should therefore be useful in applications such as the synthesis of antisense oligonucleotides.

In the present version this method is slightly more laborious and time consuming than standard synthesis, although both the triethylamine wash and TBAF cleavage can be performed automatically on existing DNA synthesizers. We have also used crosslinked polystyrene particles (10  $\mu\text{m}$  diameter), derivatized with hydroxylalkyl functions (Mono R; a kind gift from Björn Ekström, Pharmacia, Uppsala) as supports for synthesis (15). These particles were not optimized for oligonucleotide synthesis, and resulted in coupling yields lower than usual. However, this non-silica based matrix displayed important advantages compared with CPG. Unlike CPG, the support was resistant to conc. aqueous ammonia, allowing this standard reagent to be used for fast cleavage of apurinic sites, in place of triethylamine as in the procedure described herein, and further, the polystyrene support does not compete with the disiloxy linker for fluoride ions during deprotection. Moreover, after ammonia treatment, deprotected oligonucleotides could be incubated with an exonuclease while still on the support, as an alternative to chromatographic isolation of trityl-containing oligonucleotides. This step should remove both cleaved depurinated molecules and ones capped after their synthesis has been prematurely terminated, while intact molecules, retaining the trityl groups, are spared from exonucleolytic digestion (21).

Oligonucleotides synthesized according to the method presented here still include some shorter products. In the oligonucleotide circularization experiment considerably shorter molecules were observed that could still be ligated. These molecules, lacking several internal nucleotides, could arise as a consequence of insufficient stability of the cap that is added to molecules that have failed to incorporate a nucleotide. In this manner synthesis might resume several cycles after a cap was added (22). By using a reactive phosphorylating reagent in the capping step instead of acetic anhydride, the amount of deleted fragments has been reduced (22,23). The overall quality of oligonucleotide synthesis could be further improved through a detritylation procedure that results in a lower ratio of depurination (24). We currently apply these measures in conjunction with the present support to find an optimal oligonucleotide synthesis procedure.

## ACKNOWLEDGEMENTS

We thank Dr Francis Barany for providing the *Tth* ligase. Johan

Banér and Fredrik Österberg provided excellent technical assistance. This work was supported by grants from the Beijer Foundation, the Swedish Research Council for Engineering Sciences and from Swedish Cancer Society.

## REFERENCES

- 1 Nilsson,M., Malmgren,H., Samiotaki,M., Kwiatkowski,M., Chowdhary, B.P. and Landegren,U. (1994) *Science*, **265**, 2085–2088.
- 2 McClain,W.H., Foss,K., Mittelstadt,K.L. and Schneider,J. (1986) *Nucleic Acids Res.*, **14**, 6770.
- 3 Nassal,M. (1988) *Gene*, **66**, 279–294.
- 4 Agback,P., Maltseva,T.V., Yamakage,S.I., Nilson,F.P., Foldesi,A. and Chattopadhyaya,J. (1994) *Nucleic Acids Res.*, **22**, 1404–1412.
- 5 Gelfi,C., Perego,M., Morelli,S., Nicolin,A. and Righetti,P.G. (1996) *Antisense Nucleic Acid Drug Dev.*, **6**, 47–53.
- 6 Horn,T. and Urdea,M.S. (1988) *Nucleic Acids Res.*, **16**, 11559–11571.
- 7 Sproat,B.S. and Brown,D.M. (1985) *Nucleic Acids Res.*, **13**, 2979–2987.
- 8 Venkatesan,H. and Greenberg,M.M. (1996) *J. Org. Chem.*, **61**, 525–529.
- 9 Efimov,V.A., Kalinkina,A.L. and Chakhmakhcheva,O.G. (1995) *Russ. J. Biorg. Chem.*, **21**, 527–531.
- 10 Kumar,P., Bose,N.K. and Gupta,K.C. (1991) *Tetrahedron Lett.*, **32**, 967–970.
- 11 Holmberg,L. (1992) *PCT WO 92/09615*.
- 12 Markiewicz,W.T. (1979) *J. Chem. Res.*, (M), 0181–0197.
- 13 Sinha,N.D., Biernat,J. and Köster,H. (1983) *Tetrahedron Lett.*, **24**, 5843–5846.
- 14 Connolly,B.A. (1987) *Tetrahedron Lett.*, **28**, 463–466.
- 15 Pon,R.T. (1993) In Agrawal,S. (ed.), *Methods in Molecular Biology. Protocols for Oligonucleotides and Analogs*. Humana Press Inc., Totowa, NJ, pp. 465–496.
- 16 Atkinson,T. and Smith,M. In Gait,M.J. (ed.) (1984) *Oligonucleotide Synthesis: A Practical Approach*. IRL Press, Oxford, pp. 35–80.
- 17 Temsamani,J., Kubert,M. and Agrawal,S. (1995) *Nucleic Acids Res.*, **23**, 1841–1844.
- 18 Fearon,K.L., Stults,J.T., Bergot,B.J., Christensen,L.M. and Raible,A.M. (1995) *Nucleic Acids Res.*, **23**, 2754–2761.
- 19 Arghavani,M.B. and Romano,L.J. (1995) *Anal. Biochem.*, **231**, 201–209.
- 20 Iyer,R.P., Yu,D., Jiang,Z. and Agrawal,S. (1995) *Nucleosides Nucleotides*, **14**, 1349–1357.
- 21 Horn,T. and Urdea,M.S. (1985) *Nucleic Acids Res. Sym. Ser.*, **16**, 153–156.
- 22 Yu,D., Tang,J., Iyer,R.P. and Agrawal,S. (1994) *Tetrahedron Lett.*, **35**, 8565–8568.
- 23 Andrus,A., Efcavitch,J.W., McBride,L.J. and Giusti,B. (1988) *Tetrahedron Lett.*, **29**, 861–864.
- 24 Mitchell,M.J., Hirschowitz,W., Rastinejad,F. and Lu,P. (1990) *Nucleic Acids Res.*, **18**, 5321.