

Induction of immunological memory in the skin. Role of local T cell retention

R. J. SCHEPER, MARY VON BLOMBERG, G. H. BOERRIGTER, D. BRUYNZEEL,
ANS VAN DINTHER & ANNEMIEKE VOS *Department of Pathology, Free University
Hospital, Amsterdam, The Netherlands*

(Accepted for publication 13 August 1982)

SUMMARY

Using an experimental contact sensitivity model in guinea-pigs, evidence is presented that hapten (DNCB or oxazolone) specific T lymphocytes may persist for several months in previous sites of inflammation. Immunological memory, revealed by accelerated contact skin reactions upon retesting with the hapten, was limited to the original contact skin reaction sites. This 'local skin memory' to DNCB or oxazolone could be induced in both specific and non-specific skin inflammatory reactions, provided the animals had been sensitized to the hapten not longer than 2 weeks before. In animals which had been sensitized more than 1 month earlier, local skin memory could be induced if the animals received a booster application of hapten shortly (0–2 days) before primary skin testing. From these results we conclude that recently activated T cells may enter inflammatory sites non-specifically, producing specific local immunological memory. This memory may last several months. Accumulation of hapten specific T cells at inflammatory sites may be important in retest reactivity, in flare-up reactivity and in chronic inflammation.

INTRODUCTION

Skin lesions that have healed may exhibit an enhanced response to inflammatory stimuli for a long period of time. An example of this phenomenon is the accelerated delayed hypersensitivity reaction observed in retest reactions, as described by Arnason & Waksman (1963).

Several mechanisms have been proposed to explain a local increase in immunological reactivity. Bleumink & Jansen (1972), Polak, Turk & Frey (1973), Leber, Milgrom & Cohen (1973), Nakawaga *et al.* (1978) suggested that local retention of T cells was important. On the other hand, when studying local flare-up reactions in chromium allergy, Polak, Frey & Turk (1970) obtained evidence for local antibody production. B cell retention (Baine & Thorbecke, 1982) or antigen retention (van Beusekom *et al.*, 1981) may also contribute to local immunological memory.

In the present study an experimental model of contact sensitivity in guinea-pigs was used to identify conditions of T cell retention producing local skin memory in retest reactions. As the arrival of antigen specific T cells at inflammatory sites is now known to depend on the state of activation of the cells (Asherson & Allwood, 1972; Rose, Parrott & Bruce, 1978; Hall, Hopkins & Reynolds, 1980; Jungi, 1980; van Dinther Janssen, van Maarsseveen, de Groot & Scheper, unpublished results) the ability of recently sensitized, or re-immunized animals to develop local skin memory at inflammatory sites, was compared to the response of animals that had been sensitized long before.

The results of the present study are consistent with the view that shortly after primary contact

Correspondence: R. J. Scheper, Department of Pathology, Free University Hospital, De Boelelaan 1117, 1081 HV Amsterdam, The Netherlands.

sensitization, or re-exposure, hapten specific T lymphocytes are most capable of migrating into skin test sites, irrespective of the agents used for the challenge. The persistence of hapten specific lymphocytes at skin test sites can mediate a long lasting local hyper-reactivity to a subsequent challenge with the hapten.

MATERIALS AND METHODS

Animals. Outbred albino female guinea-pigs (TNO, Holland), weighing 200–300 g, were used in most experiments. Cell transfer studies were performed with strain 13 inbred guinea-pigs which were kindly provided by Dr H.A. Brouwer (Department of Experimentale Geneeskunde, Free University, Amsterdam).

Sensitization. Groups of guinea-pigs were sensitized by epicutaneous application of 0.15 ml of a 4% (w/v) solution of DNCB (2,4-dinitrochlorobenzene) in 96% ethanol on both ears. In most experiments the animals were simultaneously sensitized to oxazolone (4-ethoxymethylene-2-phenyl oxazolone) by epicutaneous application of 0.15 ml of a 5% (w/v) solution of oxazolone in ethanol on both ears, 1 hr before the application of DNCB. In one experiment guinea-pigs were sensitized by four intradermal injections of a total of 0.5 mg DNFB and 0.5 ml oxazolone homogenized in 0.5 ml Freund's complete adjuvant (FCA) containing mycobacterial strain H₃₇RA (DIFCO Labs, Detroit, Michigan, USA) into the footpads.

T cell transfer. Lymphoid cell suspensions were prepared from groups of at least five DNCB sensitized strain 13 guinea-pigs by teasing the pooled draining auricular, cervical and tracheal lymph nodes in RPMI 1640, filtered through gauze, washed and resuspended in RPMI 1640 containing 10% heat-inactivated FCS at a concentration of 5×10^7 cells/ml. One passage through nylon wool columns was used to obtain enriched T cell suspensions that contained between 1 and 5% Ig positive cells by immunofluorescence, and less than 0.8% esterase positive cells. Viability was always higher than 85% as determined by eosin exclusion.

Lymphocyte rich peritoneal exudate cell (PEC) suspensions were obtained from DNFB/FCA pre-immunized strain 13 guinea-pigs that received several (three times weekly for at least 4 weeks) i.p. injections of PPD (10 μ g in 1 ml saline). These peritoneal cells were collected 48 hr after the last injection. Contaminating macrophages were removed by filtration on nylon wool. Resulting peritoneal exudate lymphocyte suspensions (PEL) contained less than 4% B cells (van den Berg *et al.*, 1980).

T cell recipients received 2×10^8 viable lymph node T cells or 5×10^7 PEL in 1 ml of RPMI by intravenous injection into an ear vein, 1–2 hr after primary skin testing.

Skin testing. Primary skin tests were performed only on the right flank by the epicutaneous application of 50 μ l of 0.3% DNCB, 5% oxazolone or 1% croton oil (Sigma, St Louis, Missouri, USA) in ethanol.

All guinea-pigs received secondary skin tests at both the previous, marked reaction sites ('retest' reactions) and at opposite sites (control reactions).

Skin tests were evaluated after 7, 24 and 48 hr by grading the intensity of erythema on a numerical scale of 0–3 as described earlier (von Blomberg, Boerrigter & Scheper, 1978; Scheper *et al.*, 1977).

RESULTS

Time course of retest reactions

Guinea-pigs were sensitized by epicutaneous application of DNCB on the ears and skin tested (50 μ l, 0.3%) 2 weeks later on the right flank (Fig. 1). Skin test reactions were maximum at 24 hr (mean erythema \pm s.d.: 1.2 ± 0.3 ; $n = 6$), and became negative within the next 48 hr. Fourteen days after the primary skin test, secondary skin reactions were elicited (20 μ l, 0.3%) both on the left flank (control reaction) and on the former skin reaction sites (retest reaction).

As can be seen in Fig. 1, retest reactivity was characterized by an accelerated onset of the contact

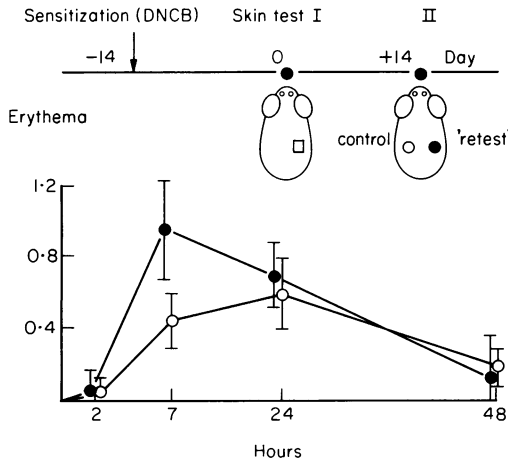

Fig. 1. Time courses of retest (●—●) and control (○—○) contact skin reactions to DNCB. For technical details see experimental scheme and Materials and Methods section. Each value represents the mean \pm s.d. calculated from six guinea-pigs.

skin reaction at 7 hr. Readings made at 24 and 48 hr do not show significant differences between retest and control reactions. For that reason, further results will be presented as differences between control and retest skin reactions at 7 hr after the secondary skin tests.

Local skin memory can be mediated by T cells

T cell transfer experiments were performed in order to verify that retest reactivity can be mediated by the local persistence of antigen specific T cells that have accumulated during an earlier inflammation. T cell suspensions purified on nylon wool were obtained from inbred strain 13 guinea-pigs that had been painted with DNCB 5 days earlier. The cell suspensions were transferred intravenously into syngeneic recipients. The recipients were skin tested on the right flank with DNCB and a non-specific irritant, croton oil. Two weeks later local DNCB specific memory was assessed by a second challenge at the same sites.

Specific skin reaction sites (Fig. 2, group 1), and non-specific reaction sites (Fig. 2, group 4) attracted sufficient numbers of transferred hapten specific T cells to exhibit a retest reaction response. Similar results were obtained with guinea-pigs that had received sensitized peritoneal exudate T lymphocytes instead of lymph node derived T cells (data not shown). Animals that had not received sensitized T cells did not show accelerated reactivity to DNCB at former DNCB skin test sites or croton oil skin test sites (Fig. 2, groups 2 and 5). Furthermore, the induction of positive retest reactivity was not attributable to non-specific increase in local skin reactivity, as no effect could be demonstrated in a secondary croton oil skin test (Fig. 2, group 3).

Duration of local skin memory

Guinea-pigs were sensitized to both DNCB and oxazolone in FCA, and skin tested 3 weeks later on the right flank with both chemicals (Fig. 3). Subgroups of five guinea-pigs were retested 2, 5 or 12 weeks after the primary skin tests. All retest reactions were performed with DNCB, to compare local DNCB reactivity at former DNCB reaction sites with reactions at virgin sites as well as former oxazolone reaction sites.

Non-specific and specific retest reactivity persists for at least 5 weeks (Fig. 3). DNCB retest reactivity could be detected at former DNCB test sites as long as 12 weeks after primary skin testing, whereas after that period no acceleration of the DNCB reaction at former oxazolone test sites was observed.

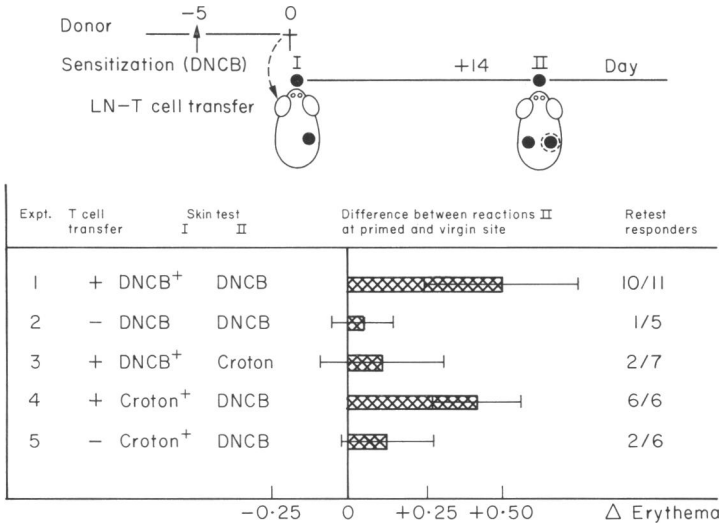

Fig. 2. Seven hour differences \pm s.d. in erythema between retest and control reactions to DNCB or croton oil in guinea-pigs which received, or did not receive, 2×10^8 viable DNCB sensitized lymph node T cells. Positive primary skin test reactions (indicated with +) were induced either by DNCB (mean erythema \pm s.d.; 1.1 ± 0.4 , 24 hr, $n = 18$) or croton oil (mean erythema \pm s.d.; 1.3 ± 0.2 , 24 hr, $n = 12$). For technical details see experimental scheme and Materials and Methods section. For each experimental group the number of animals showing a stronger retest reaction than control reaction, and the total number of animals in that group, is given in the right column ('retest responders').

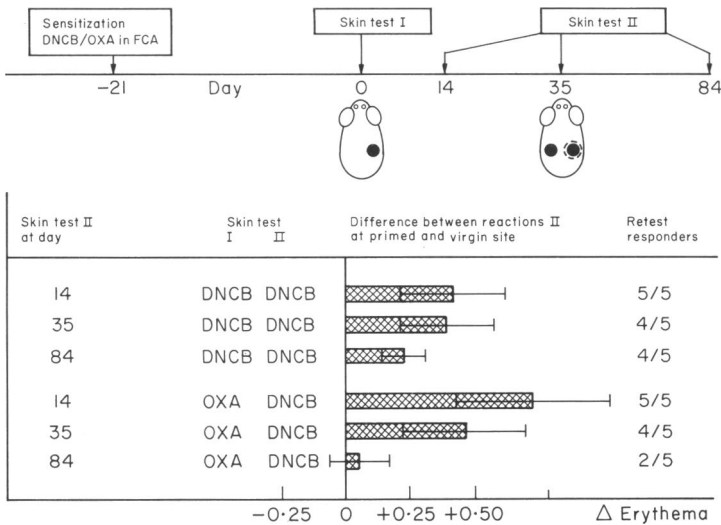

Fig. 3. Seven hour differences \pm s.d. in erythema between retest and control reactions to DNCB in guinea-pigs challenged 14, 35 or 84 days after primary skin testing with DNCB or oxazolone. For technical details see experimental scheme and Materials and Methods section. For each experimental group the fraction of animals showing a stronger retest reaction than control reaction is given in the right column.

Effect of time interval between sensitization and primary skin testing on the generation of local skin memory

The dependence of local immunological memory on the state of T cell activation was studied. For these experiments, animals were sensitized epicutaneously, as immunization with FCA induces long lasting T cell activation. Following the epicutaneous application of DNCB and oxazolone, lymph node blast cell numbers return to background values within 2–3 weeks (Scheper & Oort, 1974).

Four groups, each containing six guinea-pigs, were painted with both DNCB and oxazolone. Two groups were skin tested after 2 weeks with either DNCB or oxazolone on two sites on the right flank only.

The other groups were tested similarly after 6 weeks. No differences in intensity of erythema between reactions after 2 weeks or 6 weeks could be observed (DNCB: 1.4 ± 0.4 ; OXA: 0.9 ± 0.3 , $n=24$). Two weeks after these primary skin tests all groups were retested with both agents at the same sites on the right flank and at new sites on the left flank.

No significant local skin memory was observed in animals that had been sensitized long (6 weeks) before the primary skin tests. In contrast, local skin memory occurred in animals sensitized 2 weeks before (Fig. 4).

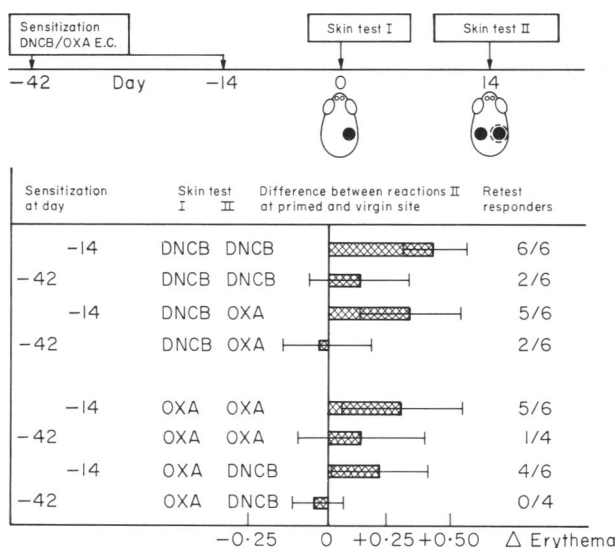

Fig. 4. Seven hour differences \pm s.d. in erythema between retest and control reaction to DNCB or oxazolone in guinea-pigs which had received primary skin tests with either DNCB or oxazolone 2 or 6 weeks after sensitization. For technical details see experimental scheme and Materials and Methods section. For each experimental group the fraction of animals showing a stronger retest reaction than control reaction is given in the right column.

Effect of reimmunization on the generation of local immunological memory in a non-specific skin test site

It was investigated whether the lack of induction of local skin memory in immunologically 'resting' guinea-pigs, could be reversed by an antigenic booster. Groups of guinea-pigs that had been sensitized by contact to both DNCB and oxazolone 6 weeks earlier, received a second dose of DNCB (50 μ l, 1%) on both ears at 5, 2 or 0 days before a challenge with oxazolone. A control group received the booster dose of DNCB 5 days after the oxazolone challenge. No differences in intensity of erythema to the oxazolone challenge were observed in these groups (0.9 ± 0.3 , $n=35$). Four weeks later, all guinea-pigs were retested with DNCB on the former oxazolone site and on virgin sites.

Shortly (0–2 days) after restimulation with DNCB, local skin memory to this hapten was induced in oxazolone skin test sites (Fig. 5). This phenomenon appears to be transitory, as an

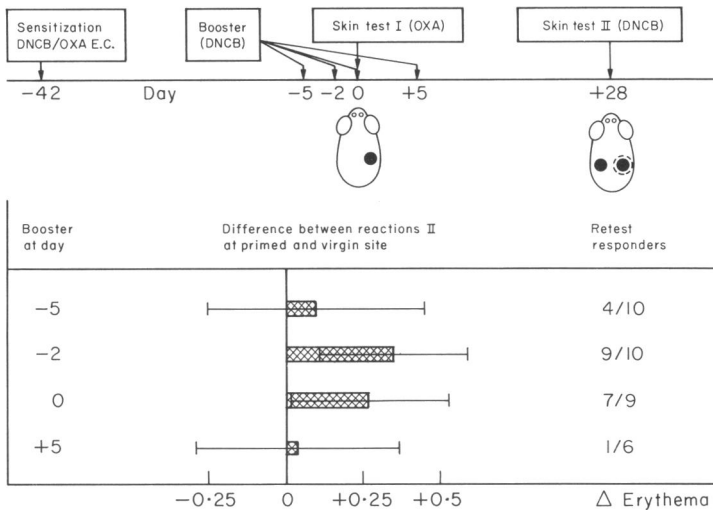

Fig. 5. Seven hour differences \pm s.d. in erythema between retest and control reaction to DNCB in guinea-pigs which had been skin tested with oxazolone 6 weeks after sensitization. All guinea-pigs received a booster dose of DNCB on the ears -5, -2, 0 or +5 days before or after the oxazolone skin test. For technical details see experimental scheme and Materials and Methods section. For each experimental group the fraction of animals showing a stronger retest reaction than control reaction is given in the right column.

exposure to DNCB 5 days before the oxazolone skin test did not induce local skin memory to DNCB.

DISCUSSION

These experiments show that hapten specific T lymphocytes may persist for several weeks at former inflammatory sites, and may cause a local hypersensitivity detectable by a subsequent challenge with the hapten. This phenomenon can be formally demonstrated by T cell transfers of retest reactivity.

Although antigen persistence may play an important role in local hyperreactivity in chronic inflammatory reactions (van Beusekom *et al.*, 1981), the data presented here, show that antigen persistence is not a necessary condition for the induction of local immunological memory in the skin (Fig. 2, group 4). It also appears that neither B cells nor their products are required for the development of local immunological memory in the skin, as it is highly unlikely that, following the passive transfer of purified DNCB sensitized T cells into non-sensitized recipients, skin testing with croton oil could locally activate DNCB specific B cells. On the other hand, it has been suggested that the local persistence of antibodies or antibody producing cells is responsible for 'flare-up' reactions in the skin (Polak *et al.*, 1970), and increased local immune reactivity in lymph nodes (Baine & Thorbecke, 1982). As antibody producing cells are known to be important in the histopathology of chronic inflammatory reactions, studies to clarify the role of local antibody-mediated memory in skin inflammations have been initiated.

Local immunological memory in this study was manifested by accelerated and more intense local contact hypersensitivity. In an earlier report accelerated local lymphokine release was shown to parallel such retest reactivity. The lymphokine release was maximum at 7 hr after the challenge (van Maarsseveen, Bomhof & Scheper, 1981). An acceleration of the onset of the skin reaction appears to be the major functional consequence of local T cell memory, as retest reactions at later times (24 hr and more) generally do not differ from reactions at virgin sites. The biological advantage for host resistance of an accelerated response at sites that are frequently exposed to infectious agents is obvious (Poulin *et al.*, 1980; Jungi, 1980).

From the present study it appears that recently activated T cells may enter inflammatory sites non-specifically. This conclusion is in agreement with earlier work in many species showing that T cell blasts and their recent progeny are highly efficient in migration into inflammatory reaction sites (in mice: Asherson & Allwood, 1972; Rose *et al.*, 1978; in rats: Jungi, 1980; in guinea-pigs: van Dinther-Janssen *et al.*, unpublished observations). The present retest experiments demonstrate that non-specific accumulation of hapten specific T cells at inflammatory sites may have functional implications. With the model described here we have also been able to detect T cell retention in both specific and non-specific skin inflammatory sites by eliciting flare-up reactions by intravenous introduction of the allergen (Scheper, unpublished results). In chronic illnesses this mechanism may explain the disease promoting effect of any allergen regularly present in the food or administered parenterally.

The failure to induce local skin memory in immunologically 'resting' animals could result from a redistribution of most antigen specific T cells that depletes these T cells from the recirculating pool (Jungi, 1980). A second exposure to the hapten may stimulate a transient increase in such T cells that accumulate non-specifically at sites of inflammation. Specific tests for these cells reveal their presence. Hashim, Yee & Ramey (1980) have reported that specifically activated T cells can be detected in the circulation from 0.5 to 24 hr following a second injection of antigen into guinea-pigs that had been sensitized 6 weeks earlier. That observation is in agreement with our finding that increased hapten specific accumulation of T cells into skin test reactions may occur even when reimmunization and primary skin tests are performed on the same day.

The results of this study are in agreement with the old observation that most T cells at a specific site are non-specific cells, i.e. specific for antigens different from the eliciting antigen (Turk & Oort, 1963; McCluskey, Benacerraf & McCluskey, 1963). However, small differences between results obtained by retesting with the same or a different hapten as used for primary skin testing (Figs 3 & 4) suggest that selective entry and/or retention may play a role in contact sensitivity. Furthermore, specificity in retest reactivity has been observed by others (Leber *et al.*, 1973; Nakagawa *et al.*, 1978), whereas some degree of antigen specific T cell selection at inflammatory sites could be detected in several studies (Emeson, 1978; Hopkins, McConnell & Lachman, 1981).

In conclusion, our results support the view that increased local skin reactivity to an antigen may be caused by the local persistence of antigen specific T lymphocytes. Those cells may accumulate as a consequence of non-antigen specific stimuli. Their accumulation is optimum if the non-specific inflammation is elicited shortly after primary specific immunization or boosting. T cell retention may be relevant in a number of clinical manifestations of local hyper-reactivity, e.g. in the skin (Mitchell, 1975; Dahlbäck & Möller, 1981) and in rheumatic lesions (Glynn, 1968; van Beusekom *et al.*, 1981).

We thank Mr J. de Groot for excellent technical assistance. We also thank Drs H.A. Drexhage, B. Noble, L. Polak and M. Scheper-Smit for their critical review of the manuscript, and Mrs Y.C. Abraham-Dolman and Mr W.R. Dolman for secretarial assistance in preparation of the manuscript.

REFERENCES

- ARNASON, B.G. & WAKSMAN, B.H. (1963) The retest reaction in delayed sensitivity. *Lab. Invest.* **12**, 737.
- ASHERSON, G.L. & ALLWOOD, G.G. (1972) Inflammatory lymphoid cells. Cells in immunized lymph nodes that move to sites of inflammation. *Immunology*, **22**, 493.
- BAINE, Y. & THORBECKE, G.J. (1982) Induction and persistence of local B cell memory in mice. *J. Immunol.* **120**, 639.
- BERG, W.B. VAN DEN, MAARSVEEN, A.C.M. TH. VAN, MULLINK, H. & SCHEPER, R.J. (1980) Accumulation of T cells and local anti-PPD antibody production in lymphokine-mediated chronic peritonal inflammation in the guinea pig. *J. Pathol.* **132**, 23.
- BEUSEKOM, H.J. VAN, PUTTE, L.B.A. VAN DE, BERG, W.B. VAN DEN, BROEK, W.J.M. VAN DEN & BUIJS, W.C.A.M. (1981) Antigen handling in antigen-induced joint inflammation: kinetics of a second intra-articularly injected dose of antigen in an already established antigen-induced joint inflammation. *Immunology*, **44**, 153.
- BLEUMINK, E. & JANSEN, L.H. (1972) Studies on flare and rash phenomena in guinea pigs. *Arch. Derm. Forsch.* **212**, 285.
- BLOMBERG, M. VON, BOERRIGTER, G.H. & SCHEPER,

- R.J. (1978) Interference of simultaneous skin tests in delayed hypersensitivity. *Immunology*, **35**, 361.
- DAHLBÄCK, K. & MÖLLER, H. (1981) Flare-up of contact dermatitis to picryl chloride in the mouse. *Acta Dermat.* **61**, 342.
- EMESON, E.E. (1978) Migratory behaviour of lymphocytes with specific reactivity to alloantigens. II. Selective recruitment to lymphoid cell allografts and their draining lymph nodes. *J. exp. Med.* **147**, 13.
- GLYNN, L.E. (1968) The chronicity of inflammation and its significance in rheumatoid arthritis. *Ann. rheum. Dis.* **27**, 105.
- HALL, J.G., HOPKINS, J. & REYNOLDS, J. (1980) Studies of efferent lymph cells from nodes stimulated with oxazolone. *Immunology*, **39**, 141.
- HASHIM, G.A., YEE, N. & RAMEY, W.G. (1980) The kinetics of T lymphocyte subpopulations in guinea-pigs sensitized with allogeneic transplantation antigens. *Clin. exp. Immunol.* **41**, 533.
- HOPKINS, J., MCCONNELL, I. & LACHMANN, P.J. (1981) Specific selection of antigen-reactive lymphocytes into antigenically stimulated lymph nodes in sheep. *J. exp. Med.* **153**, 706.
- JUNGI, T.W. (1980) Nonrecirculating memory T-lymphocytes in cellular resistance to infection. *Cell. Immunol.* **55**, 499.
- LEBER, P.D., MILGROM, M. & COHEN, S. (1973) Eosinophils in delayed hypersensitivity skin reaction sites. *Immunol. Commun.* **2**, 615.
- MAARSSEVEEN, A.C.M.TH. VAN, BOMHOF, G. & SCHEPER, R.J. (1982) Demonstration of accelerated and increased migration inhibition factor release *in vivo* in a PPD retest reaction. *Int. Arch. Allergy appl. Immunol.* **67**, 1.
- MCCCLUSKEY, R.T., BENACERRAF, B. & MCCCLUSKEY, J.W. (1963) Studies on the specificity of the cellular infiltrate in delayed hypersensitivity reactions. *J. Immunol.* **90**, 466.
- MITCHELL, J.C. (1975) The angry-back syndrome: eczema creates eczema. *Cont. Dermat.* **1**, 193.
- NAKAGAWA, S., FUKUSHIRO, S., GOTOH, M., KOHDA, M., NAMBA, M. & TANIOKU, K. (1978) Studies on the retest reaction in contact sensitivity to DNCB. *Dermatologica*, **157**, 13.
- POLAK, L., FREY, J.R. & TURK, J.L. (1970) Studies on the effect of systemic administration of sensitizers in guinea-pigs with contact sensitivity to inorganic metal compounds. V. Studies on the mechanism of the flare-up reaction. *Clin. exp. Immunol.* **7**, 739.
- POLAK, L., TURK, J.L. & FREY, J.R. (1973) Studies on contact hypersensitivity to chromium compounds. In *Progress in Allergy* (ed. by P. Kallós, B.H. Waksman & A. de Weck) S. Karger, Basel, vol. 17, 145.
- POULAIN, D., TRONCHIN, G., VERNES, A., DELABRE, M. & BIGUET, J. (1980) Experimental study of resistance to infection by trichophyton mentagrophytes: demonstration of memory skin cells. *J. Invest. Derm.* **74**, 205.
- ROSE, M.L., PARROTT, D.M.V. & BRUCE, R.G. (1978) The accumulation of immunoblasts in extravascular tissues including mammary gland, peritoneal cavity, gut and skin. *Immunology*, **35**, 415.
- SCHEPER, R.J., NOBLE, B., PARKER, D. & TURK, J.L. (1977) The value of an assessment of erythema and increase in thickness of the skin reaction for a full appreciation of the nature of delayed hypersensitivity in the guinea pig. *Int. Arch. Allergy appl. Immunol.* **54**, 58.
- SCHEPER, R.J. & OORT, J. (1973) Rosette-forming cells and the immunological response after DNCB, DNP-carrier and oxazolone sensitization. *Immunology*, **26**, 269.
- TURK, J.L. & OORT, J. (1963) A histological study of the early stages of the development of the tuberculin reaction after passive transfer of cells labelled with ³H-thymidine. *Immunology*, **6**, 140.