

Metabolism of Transpired Ethanol by Eastern Cottonwood (*Populus deltoides* Bartr.)¹

Robert C. MacDonald*² and Thomas W. Kimmerer

University of Kentucky, Department of Forestry and Graduate Program in Plant Physiology, Biochemistry, and Molecular Biology, 205 T.P. Cooper Building, Lexington, Kentucky 40546-0073

Ethanol has previously been shown to be present in the xylem sap of flooded and nonflooded trees. Because of the constitutive presence of alcohol dehydrogenase in the mature leaves of woody plants, we hypothesized that the leaves and shoots of trees had the ability to metabolize ethanol supplied by the transpiration stream. 1-[¹⁴C]Ethanol was supplied to excised leaves and shoots of eastern cottonwood (*Populus deltoides* Bartr.) in short- and long-term experiments. More than 99% of the radiolabel was incorporated into plant tissue in short-term experiments, with more than 95% of the label remaining in plant tissue after 24 h. In all experiments, less than 5% of the label was transpired as ethanol and less than 1% was emitted as CO₂. In excised leaf experiments, less than 0.5% of the radiolabel escaped from the leaf. Fifty percent of the label was incorporated into the petioles of excised leaves; 56% was incorporated into the stems of excised shoots. Very little label reached the leaf mesophyll cells of excised shoots, as revealed by autoradiography. Radiolabel appeared primarily in the water- and chloroform-soluble fractions in short-term experiments, whereas in long-term experiments, label was also incorporated into protein. These results demonstrate that the leaves and stems of trees appear to have substantial ability to scavenge ethanol from the transpiration stream, allowing efficient recovery of ethanol produced elsewhere by hypoxic tissues. When labeled ethanol was supplied to excised petioles in a 5-min pulse, 41% of the label was incorporated into organic acids. Some label was also incorporated into amino acids, protein, and the chloroform-soluble fraction, with very little appearing in neutral sugars, starch, or the insoluble pellet. Labeled organic acids were separated by high performance liquid chromatography and were composed of acetate, isocitrate, α -ketoglutarate, and succinate. There was no apparent incorporation of label into phosphorylated compounds. We conclude that, in higher plants, ethanol is metabolized to acetaldehyde and then to acetate by alcohol and aldehyde dehydrogenases, and then into general metabolism.

Although it is usually assumed that trees differ from other plants only in form, size, and longevity, there are also biochemical features that are unique to trees. One such feature is the high constitutive activity of ADH in tree leaves. From a survey of the leaves from many plant species, we found high apparent ADH activity in woody plants (both gymno-

sperms and angiosperms) and little or no activity in most herbs, forbs, and lower plants (Kimmerer and MacDonald, 1987). The leaves of eastern cottonwood (*Populus deltoides* Bartr.) constitutively express ADH activity, and this activity varies little with changes in external oxygen availability (Kimmerer, 1987). In contrast, ADH is not inducible in leaves of soybean or maize seedlings, and leaves of these plants produce little or no ethanol upon exposure to hypoxia (Freeling and Bennett, 1985; Kimmerer, 1987; Kimmerer and MacDonald, 1987).

For several years, we have been seeking an explanation for this difference. We know that tree leaves produce ethanol in response to a number of stresses (Kimmerer and Kozlowski, 1982; Kimmerer and MacDonald, 1987). In particular, tree leaves produce ethanol in response to exposure to acidic gasses such as sulfur dioxide and nitrogen oxides, apparently as the result of cytoplasmic acidification (Kimmerer and Kozlowski, 1982; MacDonald et al., 1989a). However, because high levels of acidic pollution are a relatively recent phenomenon, it is doubtful that this is the reason for constitutive activities of ADH in tree leaves.

Very high ADH activity also occurs in the vascular cambium of trees, and tree stems contain varying amounts of ethanol (Kimmerer and Stringer, 1988; MacDonald and Kimmerer, 1991). Ethanol concentrations in the transpiration stream of flooded and nonflooded trees were approximately 1 mM and 50 μ M, respectively (MacDonald and Kimmerer, 1991). Fermentation occurs in the roots and possibly stems of trees (Eklund, 1990; Harry and Kimmerer, 1991), and therefore, we have proposed that one function of ADH in leaves may be to consume ethanol carried from the stem or root system in the transpiration stream (MacDonald et al., 1989b; MacDonald and Kimmerer, 1990, 1991). Consequently, constitutive expression of ADH in leaves may serve to minimize escape of ethanol from the tree, thus allowing recovery of the carbon and energy invested in ethanol.

The pathway for ethanol metabolism is well known in animals. Ethanol is typically converted to acetaldehyde, then to acetate as a result of the actions of ADH and AldDH (Williamson and Tischler, 1979). Although it has been suggested that the same pathway is operational in higher plants, the evidence for this conclusion is circumstantial and comes from experiments with immature tissues (Cossins, 1978).

Abbreviations: ADH, alcohol dehydrogenase (EC 1.1.1.1); AldDH, aldehyde dehydrogenase (EC 1.2.1.3); LPI, leaf plastochron index; TCA, tricarboxylic acid cycle.

¹ Research supported by U.S. Department of Agriculture Competitive Grant No. 88-33520-4075. Publication No. 90-8-186 of the University of Kentucky Agricultural Experiment Station.

² Present address: USDA, NRICGP, Ag Box 2241, Washington, DC 20250-2241.

* Corresponding author; fax 1-202-401-6488.

Radiolabel from [^{14}C]ethanol has been found in acetaldehyde, TCA cycle intermediates, amino acids, and lipids in these tissues (Cossins and Turner, 1963; Cossins, 1978). Similar labeling patterns are found when tissues are supplied with [^{14}C]acetaldehyde or [^{14}C]acetate (Cossins, 1978). However, incorporation of radiolabel into acetate from ethanol has not been demonstrated in higher plants.

Our aim was to determine whether the leaves and upper stems of eastern cottonwood had the ability to metabolize ethanol present in the transpiration stream, and, if so, to determine the biochemical pathways and the tissues involved. These objectives were met by using excised leaves and shoots in radiolabeling studies, by chemical fractionation of labeled compounds, and by autoradiography.

MATERIALS AND METHODS

Incorporation of [^{14}C]Ethanol in Excised Leaves

The LPI developed by Larson and Isebrands (1971) was used. This system uses the phyllotaxy of greenhouse-grown eastern cottonwood (*Populus deltoides* Bartr.) in characterizing leaf development, designating the first unfolding leaf of 2 cm in length as LPI 0 with LPI 6 indicating the first fully expanded leaf and the first leaf to become a net source of carbon to the plant (Larson and Isebrands, 1971; Larson and Dickson, 1973).

Leaves of LPI 6 were excised from three greenhouse-grown eastern cottonwood seedlings and the end of each petiole was quickly submerged in filtered, deionized water. The petiole of each leaf was inserted through a rubber septum and recut under water. The septum was then inserted into a 0.7-mL glass tube, which was attached to a system supplying 300 μM [^{12}C]- or [^{14}C]ethanol (8.1 $\mu\text{Ci}/\text{mL}$) to the cut end of the petiole as illustrated in Figure 1. The system consisted of separate reservoirs for the [^{12}C]- and [^{14}C]ethanol connected by syringe valves. During the transfer between

ethanol solutions, the system was flushed with the appropriate solution by opening the waste valve for a short period of time. This method allowed efficient transfer between pulse and chase of the label and provided accurate measurement of the amount of each solution transpired. The excised leaf was then placed in a 19 \times 17 \times 1.5 cm Tedlar-lined (DuPont Co.) plexiglass cuvette, through which air flow was maintained at 270 mL/min. The air from the cuvette was passed through a cold finger to reduce moisture, a 40-mL glass tube filled with ToxTrap (ToxTrap Inc., Smyrna, DE) to remove transpired ethanol, and then bubbled through 10 mL of ethanolamine to remove CO_2 . The experiment was carried out in a glove box under a 1000-W low-pressure sodium vapor lamp; PPFd at the leaf was approximately 350 $\mu\text{mol m}^{-2} \text{s}^{-1}$. [^{12}C]Ethanol was supplied to the leaf for at least 1 h to achieve steady-state conditions, followed by a 1-h pulse of [^{14}C]ethanol, and then a 1-h chase. At the end of the experiment, the leaf was plunged into liquid N_2 and lyophilized to prevent further metabolism and to eliminate any unmetabolized [^{14}C]ethanol. The leaf was then sectioned into petiole, midrib, and major veins, and remaining lamina and dry weight were measured on each section. Ethanol was eluted from the ToxTrap with 10 mL of water. Radioactivity was determined in this eluate, the ethanolamine, and the condensate from the cold finger by liquid scintillation spectrometry.

For further analysis, leaves were homogenized in a Ten Broeck tissue grinder with 2 mL of ice-cold 12:5:3 (v/v/v) methanol:chloroform:water and partitioned into a water-soluble, a chloroform-soluble, and an insoluble fraction (Dickson, 1979). The chloroform-soluble fraction was dried in a rotary evaporator at 30°C and redissolved in scintillation cocktail. The insoluble pellet was combusted in a Packard Biological Oxidizer and the resulting CO_2 was trapped in CarboSorb (Packard Instrument Co.). Radioactivity in all fractions was determined by liquid scintillation spectrometry.

Incorporation of [^{14}C]Ethanol into Excised Shoots

Shoots were excised below node 6 from greenhouse-grown eastern cottonwood seedlings and attached to a supply of 300 μM [^{12}C]- or [^{14}C]ethanol (8.1 $\mu\text{Ci}/\text{mL}$) in the manner described above for excised leaves. These shoots were approximately 5 mm in diameter at the base and had no periderm formation. The shoots were supplied with [^{12}C]ethanol for at least 1 h prior to the start of a 1-h pulse of [^{14}C]ethanol. Radiolabeling was followed by a 0.5- or 24-h chase. Three replicate shoots were labeled simultaneously in a glove box, through which air flow was maintained at 450 mL/min. During the 24-h chase experiment, ethanol vapor and CO_2 were removed from the air exiting the glove box in the manner described above for the leaf cuvettes and counted. Lighting conditions were as described above for excised leaves, except that in the 24-h chase experiment, the shoots were given an 18-h photoperiod.

At the conclusion of the experiments, leaves 2 to 6 were removed and the stems were divided at nodes 2 and 5 into lower and upper stem, and a developing tip (including leaves 0 and 1). Leaves 4 and 6 were divided into lamina and petiole portions. Leaves 3 and 5 were discarded. All samples were

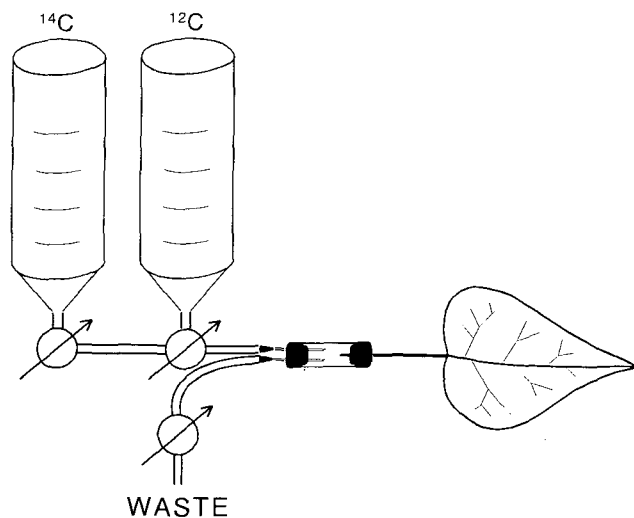

Figure 1. Apparatus used to supply [^{12}C]- or [^{14}C]ethanol in the transpiration stream to excised leaves and shoots of eastern cottonwood. Details are presented in "Materials and Methods."

immediately freeze-clamped, weighed frozen, and stored at -70°C . Fresh weight/dry weight ratios were determined on separate shoots. All samples were homogenized using a Ten Broeck tissue grinder with 5 mL of ice-cold 12:5:3 (v/v/v) methanol:chloroform:water and were separated into water- and chloroform-soluble fractions (Dickson, 1979). The chloroform-soluble fractions were dried at room temperature under a stream of nitrogen, and then redissolved in scintillation cocktail. The insoluble pellets were then treated with 36 units of protease (Sigma) in 2 mL of 50 mM Tris (pH 7.4) to solubilize the protein (Dickson, 1979). After centrifugation (1500g, 10 min), the pellets were then treated with 400 units of amyloglucosidase (Sigma) in 2 mL of 10 mM citrate (pH 5.5) to solubilize the starch (Dickson, 1979; Huber and Israel, 1982). The remaining insoluble pellet was combusted as described above, and radioactivity in all fractions was determined by liquid scintillation spectrometry. For determination of the distribution of the incorporated label among portions of the shoot, the amount of radioactivity incorporated into leaves 3 and 5 were estimated from the means of the adjacent leaves.

A subsample of the aqueous fractions from the 0.5-h chase experiment was assayed for unmetabolized [^{14}C]ethanol by HPLC using a Phenomenex Rezex Organic Acids column (300 \times 7.8 mm, 0 micron) with a 0.1-N H_3PO_4 mobile phase at a flow rate of 0.6 mL/min. The presence of radioactivity was determined by assaying 0.25-min fractions from the column using liquid scintillation spectrometry. The retention time of ethanol was determined by injection of a [^{14}C]ethanol standard.

Autoradiography

Shoots were excised from greenhouse-grown eastern cottonwood below leaf node 6 and attached to a supply of 300 μM [^{12}C]- or [^{14}C]ethanol as described above. The shoots were supplied with [^{12}C]ethanol for at least 1 h prior to the start of a 1-h pulse of [^{14}C]ethanol, which was followed by a 0.5-h chase. At the end of the chase, the shoots (with leaves 3 and 5 removed) were placed in a press, brought to -70°C , and lyophilized. Autoradiograms were made using Kodak X-Omat film and an exposure time of 10 d.

The Pathway of Ethanol Metabolism

P. deltoides leaves (LPI 6) were excised and attached to a [^{14}C]ethanol (1.5 mM, 62.5 $\mu\text{Ci}/\text{mL}$) supply system as described above. The leaves were labeled for 5 min, at which point the petioles were freeze-clamped and separated from the rest of the leaf. PPFD during the experiment was 350 $\mu\text{mol m}^{-2} \text{ s}^{-1}$. The petioles were ground in 3 mL of ice-cold 12:5:3 (v/v/v) methanol:chloroform:water and partitioned as above into water- and chloroform-soluble fractions, protein and starch fractions, and a remaining pellet. Each aqueous fraction was passed through anion-exchange resins (Bio-Rad AG3-X4A, 100–200 mesh), and then cation-exchange resins (Bio-Rad AG50W-X8, 100–200 mesh), which were eluted with 1 N HNO_3 and N NH_4OH in 80% ethanol, respectively. The void from the cation-exchange columns were dried at 30°C in a vacuum oven and rinsed several times with [^{12}C]ethanol to remove any unmetabolized [^{14}C]ethanol.

A subsample of the anion-exchange eluate for each sample was loaded onto cation-exchange resins and eluted as described above to separate out the acidic amino acids. Organic acids were separated by HPLC using a Phenomenex Rezex Organic Acids column (300 \times 7.8 mm, 0 micron) with a 0.1 N H_3PO_4 mobile phase at a flow rate of 0.6 mL/min. Radioactivity peaks were determined by assaying 0.25-min fractions from the column using liquid scintillation spectrometry. Identities of the radioactive peaks were determined by co-elution with standards and confirmed by HPLC using a 0.01 N H_2SO_4 mobile phase at a flow rate of 0.5 mL/min, after removal of interfering phosphorylated compounds by bringing the samples to pH 5.5 and treating them with 20 units/mL of acid phosphatase (Sigma) (Reckman et al., 1990). Changing the mobile phase not only results in changes in retention time, but also in the order of elution of the peaks.

RESULTS

Incorporation of [^{14}C]Ethanol into Excised Leaves and Shoots

When [^{14}C]ethanol was supplied in the transpiration stream to excised leaves, more than 99% of the radioactivity recovered was found to be incorporated into leaf tissue (Table I). The majority of the label was incorporated into vascular tissue; only 19% of the label reached the lamina. Virtually none of the label was emitted as CO_2 by the leaves during the course of the experiment. Transpiration rates of the leaves were approximately 0.5 mL/h. In a preliminary experiment, we supplied [^{14}C]ethanol in 11 mM ethanol to excised leaves; 75% of this label was incorporated into leaf tissue.

When [^{14}C]ethanol was supplied in the transpiration stream to excised shoots, greater than 95% of the radiolabel recovered remained incorporated in plant tissue after both 0.5 and 24 h of chase. Less than 0.2% of the label was emitted as CO_2 during the course of either experiment. Transpiration rates of the shoots were approximately 1 mL/h. Again, virtually all of the label was incorporated into vascular tissue (Fig. 2). No unmetabolized [^{14}C]ethanol was found in subsamples of the aqueous fractions from the 0.5-h chase experiment, as determined by HPLC. Fifty-six percent of the label was incorporated into the stem (Fig. 2A). Most of the label that did reach the laminae of the individual leaves was incorporated into the minor veins (Fig. 2B). A small amount

Table I. Incorporation of [^{14}C]ethanol into excised leaves

Three hundred micromolar [^{12}C]ethanol was supplied in the transpiration stream for at least 1 h, followed by a 1-h pulse of [^{14}C]ethanol and a 1-h chase. Data are mean \pm SE of three replicates.

Sample	Percent of Recovered ^{14}C
Petiole	50.4 \pm 3.1
Midrib	23.0 \pm 3.1
Major veins	7.4 \pm 1.0
Lamina	18.5 \pm 3.2
Emitted CO_2	0.03 \pm 0.01
Transpired ethanol	0.4 \pm 0.2

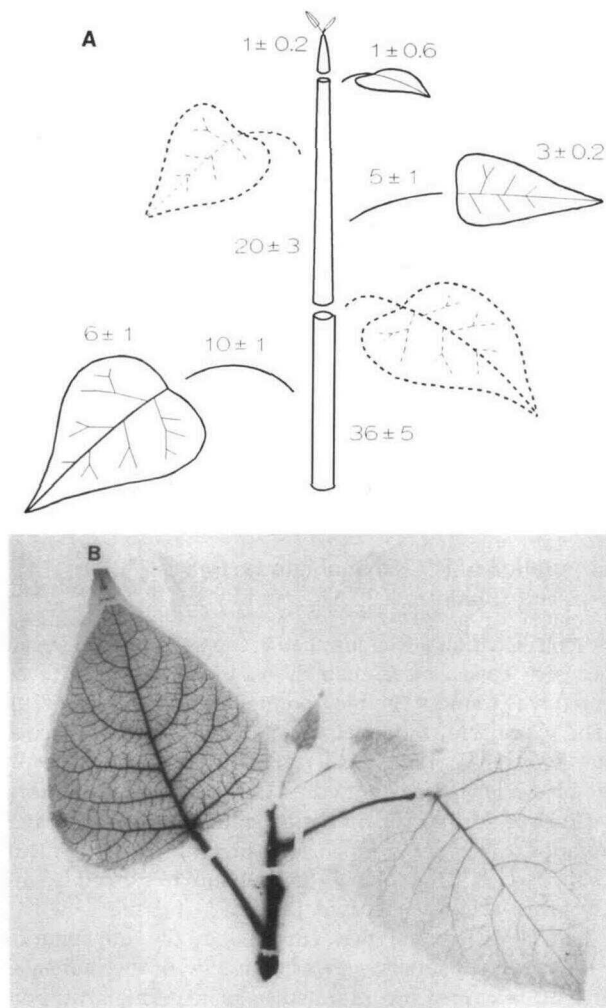

Figure 2. Incorporation of [^{14}C]ethanol into shoots of eastern cottonwood after a 1-h pulse and a 0.5-h chase. Leaves are LPI 0 to 6, top to bottom. A, Mean and SE of percent of total incorporated ^{14}C for three replicate shoots. B, An autoradiogram of a shoot, excluding leaves 3 and 5. Exposure was 10 d.

of label was incorporated into the mesophyll of leaves 2 and younger (Fig. 2B). Leaves 2 to 6 as a whole accounted for approximately 40% of the label incorporated by the shoot (Table II). There was no difference in the pattern of incorporation between the 0.5-1 and 24-h chase experiments, except for the presence of slightly more label in leaf 2 and

Table II. Incorporation of [^{14}C]ethanol into excised shoots

Foliage is the sum of LPI 2–6, including petioles. Calculations are described in "Materials and Methods." Three hundred micromolar [^{14}C]ethanol was supplied in the transpiration stream for at least 1 h, followed by a 1-h chase of [^{14}C]ethanol and a 0.5-h chase. Data are mean \pm SE of three replicates.

Sample	Percent of Incorporated ^{14}C
Stem	56.2 \pm 3.8
Foliage	43.0 \pm 3.8
Tip	0.8 \pm 0.2

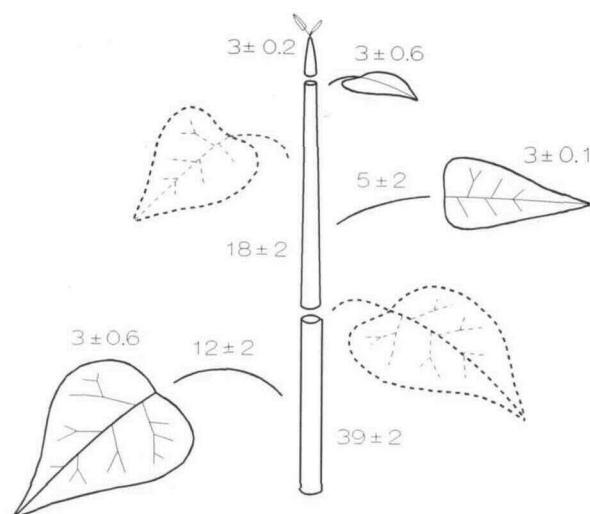

Figure 3. Incorporation of [^{14}C]ethanol into shoots of eastern cottonwood after a 1-h pulse and a 24-h chase. Leaves are LPI 0 to 6, top to bottom.

the developing tip, and slightly less label in the laminae of the older leaves following 24 h of chase (Fig. 3).

The majority of the label in the shoot experiment was incorporated into the water- and chloroform-soluble fractions (Fig. 4). Some label also appeared as protein, but very little as starch or remaining cellular debris. There were some differences in partitioning among the metabolic pools between the 0.5-1 and the 24-h chase experiments (Fig. 4). Following the 0.5-h chase, most of the label was fairly evenly divided between the water- and chloroform-soluble fractions, except in the growing tip, which had little label in the chloroform-soluble fraction (Fig. 4A). However, after 24 h, most of the label in the laminae of the older leaves was in the aqueous phase, whereas most of the label in the vascular tissues was in the chloroform-soluble phase (Fig. 4B). In addition, after 24 h, a large proportion of the label in leaf 2 and the growing tip was in protein.

Metabolism of Ethanol

The majority of the radioactivity incorporated into petioles after a 5-min pulse of [$1\text{-}^{14}\text{C}$]ethanol appeared in the water-soluble fraction (Fig. 5A). Small amounts of label also appeared in the chloroform-soluble fraction and protein, with very little in starch or the pellet. When the aqueous phase was further partitioned, 41% of the total ^{14}C incorporated was found as organic acids, with the remainder as amino acids and neutral sugars (Fig. 5B). The labeled organic acids were separated by HPLC into acetate, isocitrate, α -ketoglutarate, and succinate (Figs. 5B and 6). There was no apparent incorporation of label into phosphorylated compounds, which elute from the HPLC column between 8 and 10 min (Fig. 6).

DISCUSSION

Acetaldehyde and ethanol have previously been found in the transpiration stream of trees (Kimmerer and Stringer,

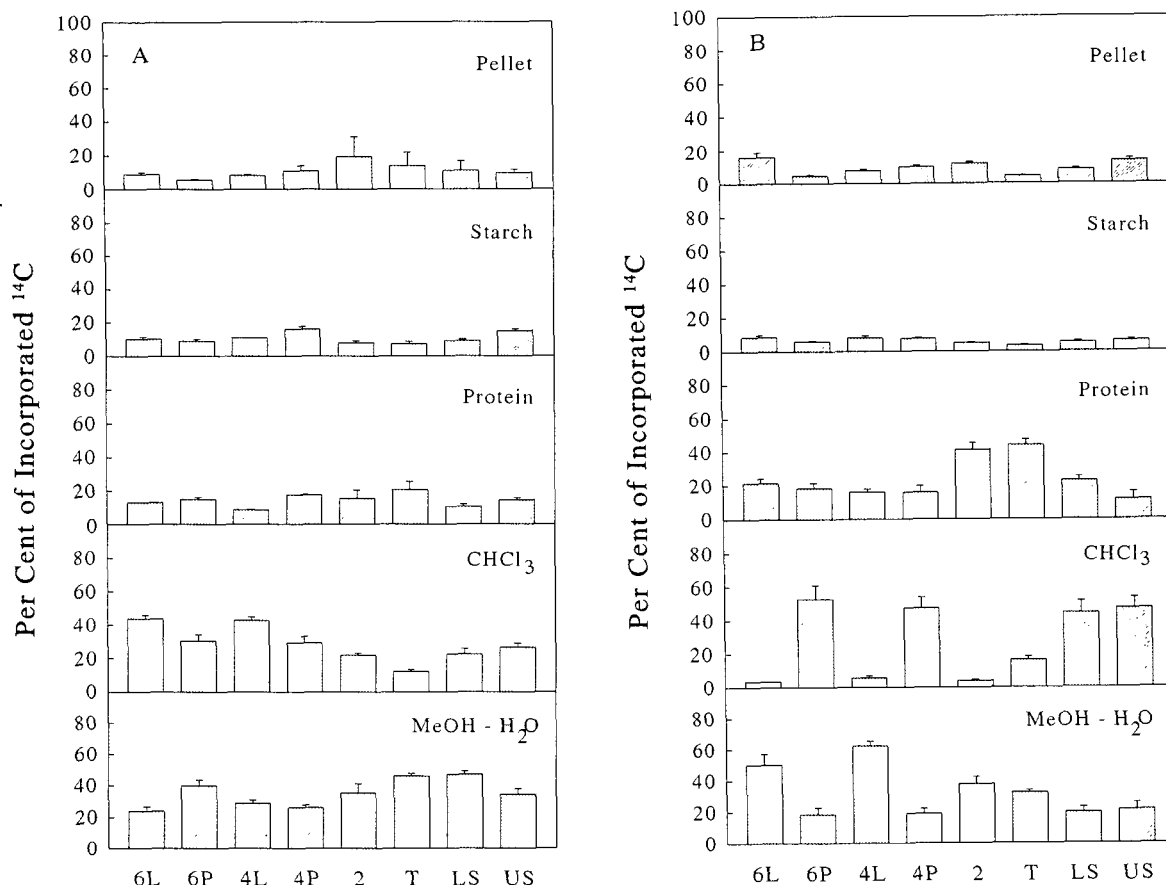

Figure 4. Incorporation of $[1-^{14}\text{C}]$ ethanol into biochemical fractions after a 1-h pulse and a 0.5-h (A) and a 24-h (B) chase. Error bars indicate the SE of three replicate shoots for each experiment. Samples are LPI 4 and 6 lamina (4L and 6L) and petiole (4P and 6P), LPI 2, growing tip (T), and lower and upper stem (LS and US).

1988; Crawford and Finegan, 1989; MacDonald and Kimmerer, 1991). In this paper, we have presented evidence that virtually all of the ethanol supplied in the transpiration stream to excised leaves and shoots of eastern cottonwood was incorporated into plant tissue. Very little $[^{14}\text{C}]$ ethanol was transpired and none was found unmetabolized in tissues after 0.5 h of chase. The leaves and stems of trees appear to have substantial ability to scavenge ethanol from the transpiration stream, allowing efficient recovery of ethanol produced elsewhere by hypoxic tissues. This result differs from that obtained with 14-d-old sunflower (*Helianthus annuus*), in which some of the ethanol in the xylem sap was metabolized by the shoot, but some was also transpired (Jayasekera et al., 1990). Unfortunately, the methods used in the sunflower paper do not allow absolute determination of the proportion of ethanol transpired. That at least some of the ethanol in the xylem sap of sunflower was transpired is probably the result of the difference in shoot ADH activities between the plant species.

Most of the labeled ethanol was recovered in the vascular tissues, with very little reaching the mesophyll cells of the leaves. Incorporation of label in the vascular tissues might have occurred by diffusion of ethanol from the xylem vessels to the associated parenchyma cells, where the ethanol could

have been metabolized. The apparent lack of label in the leaf mesophyll cells is not evidence for a low ability of the mesophyll to metabolize ethanol, but instead, probably reflects the mesophyll's position as last in line to receive compounds present in the transpiration stream. Radiolabel was apparent at the vein endings in the autoradiogram, yet very little label escaped from the leaf. Therefore, the mesophyll may have been responsible for metabolism of some of the ethanol supplied in the transpiration stream.

The pathway for ethanol metabolism in animals involves the conversion of ethanol to acetaldehyde by ADH, followed by conversion of acetaldehyde to acetate by AldDH (Williamson and Tischler, 1979). The same pathway has been proposed for metabolism of ethanol by immature tissues in higher plants, but the evidence for this hypothesis has been circumstantial (Cossins, 1978). The acetate produced from ethanol metabolism can then be used to synthesize acetyl-CoA by acetate-CoA ligase (EC 6.2.1.1), and then enter general metabolism including the TCA cycle and lipid synthesis. Label entering the TCA cycle can be directed through amino acids into protein or respired as CO_2 . Because of the location of the label on the C-1 position of ethanol and the randomization that would occur in the TCA cycle as fumarate, the label could enter gluconeogenesis as phosphoenol-

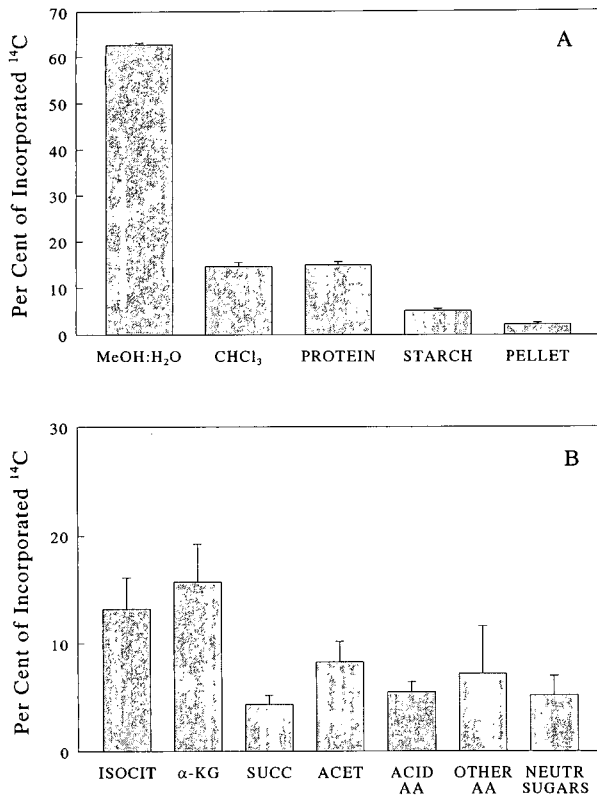

Figure 5. Incorporation of [$1\text{-}^{14}\text{C}$]ethanol into biochemical fractions of the petiole of leaf 6 after a 5-min pulse (A). The water-soluble fraction was further partitioned by ion-exchange chromatography and HPLC (B). Compounds in B are isocitrate and α -ketoglutarate, succinate, acetate, acidic amino acids, basic and neutral amino acids, and neutral sugars. Error bars are the SE of three replicate petioles.

pyruvate or be lost as CO_2 by the action of phosphoenolpyruvate carboxykinase (EC 4.1.1.38).

When petioles were supplied with labeled ethanol for 5 min, we did find radiolabeled acetate. Most of the rest of the label was in other compounds in the aqueous fraction such as TCA cycle intermediates and amino acids. In the long-term experiments, we found radiolabel primarily in the water- and chloroform-soluble fractions, and in protein, in proportions depending on their location in the shoot. We have previously found ADH activities in the leaves and shoots of eastern cottonwood (Kimmerer, 1987; Kimmerer and Stringer, 1988). Both cytosolic and mitochondrial AldDH activities have been found in higher plants (Oppenheim and Castelfranco, 1967; Asker and Davies, 1985). These results, particularly the substantial presence of label in acetate, lead us to conclude that ethanol metabolism in the upper portions of trees follows the proposed pathway to acetate, with the exact form of label in the long term depending on the metabolism of the particular tissue in question.

Some of the radiolabel in the C-1 position of ethanol should be lost as CO_2 when oxaloacetate is shunted to gluconeogenesis or it should be respired the second time around the TCA cycle during the conversion of isocitrate to

α -ketoglutarate. However, in these experiments, virtually none of the radiolabel from [$1\text{-}^{14}\text{C}$]ethanol was emitted as CO_2 . This result was also obtained when ethanol metabolism was studied in pea cotyledons, where it was proposed that radiolabel either was being diluted into large storage pools of organic acids or was being directed primarily into the synthesis of glutamate (Cameron and Cossins, 1967). It is unlikely that the first hypothesis was the case for the studies presented here, because very little $^{14}\text{CO}_2$ was emitted even after 24 h of chase. This period of time should be long enough to allow for some turnover of the organic acid storage pool. The second hypothesis is more tenable, particularly because most of the label incorporated in the short-term experiment was found in early TCA cycle intermediates that are precursors to glutamate and also in amino acids. Over time, a fair amount of the label was incorporated into protein. However, it would be surprising if less than 1% found its way through the TCA cycle to be respired. An alternative explanation exists in light of recent findings that CO_2 dissolved in the transpiration stream is efficiently fixed in the vascular tissues of excised leaves (Stringer and Kimmerer, 1990). It is possible that some of the radiolabel from metabolized ethanol was respired, but then refixed by photosynthesis before it could escape from the shoot. No label was found in phosphorylated compounds in the 5-min experiment, but label was found in neutral sugars and starch. Label in these compounds could only result from CO_2 fixation or from gluconeogenesis.

It is apparent that not only the leaves, but the smaller stems of trees have substantial ability to prevent the escape of ethanol from the transpiration stream into the atmosphere. The incorporation of ethanol by these tissues mimics the metabolism of lactate in animals. In vigorously exercising mammals, lactate produced in hypoxic muscles enters the bloodstream. During rest, when oxygen is plentiful, the lactate in the blood is converted back to Glc in the liver by gluconeogenesis. This Glc can then be respired aerobically (Lehninger, 1982). Therefore, despite the inherent ineffi-

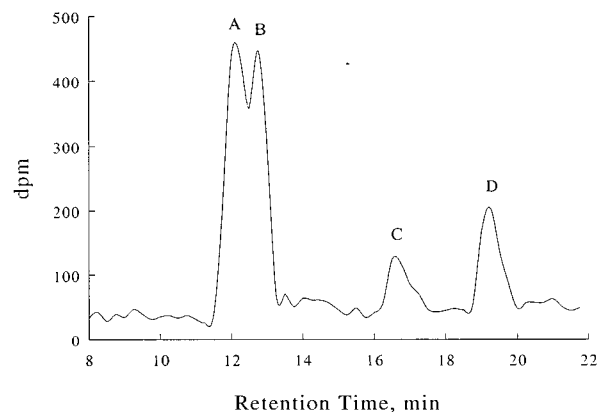

Figure 6. A typical chromatogram of the anion-exchange eluate as separated by HPLC using a Phenomenex Rezex Organic Acids column and a mobile phase of 0.1 N H_3PO_4 at 0.6 mL/min. Petioles were labeled with [$1\text{-}^{14}\text{C}$]ethanol for 5 min. Peaks are isocitrate (A), α -ketoglutarate (B), succinate (C), and acetate (D).

ciency of lactate fermentation as compared with aerobic respiration, mammals are able to maintain maximal respiratory efficiency on a whole-organism basis as a result of their ability to recycle lactate. Similarly, it is now apparent that the aerobic portions of trees remobilize ethanol produced in hypoxic parts of the plant, allowing full respiratory efficiency to be maintained on a whole-plant basis, as well as preventing the loss of carbon to transpired ethanol.

ACKNOWLEDGMENTS

The authors would like to express their appreciation to Meg Buxton, Frank Ueltschi, Rose Harmon, and John Scott for their technical assistance, and to Dr. Leslie Weston for the use of her biological oxidizer. We also thank Jeffrey W. Stringer and Dr. George Wagner for their assistance and useful discussions.

Received August 24, 1992; accepted November 18, 1992.

Copyright Clearance Center: 0032-0889/93/102/0173/07.

LITERATURE CITED

- Asker H, Davies DD (1985) Mitochondrial aldehyde dehydrogenase from higher plants. *Phytochemistry* **24**: 689–693
- Cameron DS, Cossins EA (1967) Studies of intermediary metabolism in germinating pea cotyledons. *Biochem J* **105**: 323–331
- Cossins EA (1978) Ethanol metabolism in plants. In DD Hook, RMM Crawford, eds, *Plant Life in Anaerobic Environments*. Ann Arbor Science Publishers, Ann Arbor, MI, pp 169–202
- Cossins EA, Turner ER (1963) The metabolism of ethanol in germinating pea seedlings. *J Exp Bot* **14**: 290–298
- Crawford RMM, Finegan DM (1989) Removal of ethanol from lodgepole pine roots. *Tree Physiol* **5**: 53–61
- Dickson RE (1979) Analytical procedures for the sequential extraction of ¹⁴C-labeled constituents from leaves, bark and wood of cottonwood plants. *Physiol Plant* **45**: 480–488
- Edlund L (1990) Endogenous levels of oxygen, carbon dioxide and ethylene in stems of Norway spruce trees during one growing season. *Trees* **4**: 150–154
- Freeling M, Bennett DC (1985) Maize Adh1. *Annu Rev Genet* **19**: 297–323
- Harry DE, Kimmerer TW (1991) Molecular genetics and physiology of alcohol dehydrogenase in woody plants. *For Ecol Manage* **43**: 251–272
- Huber SC, Israel DW (1982) Biochemical basis for partitioning of photosynthetically fixed carbon between starch and sucrose in soybean, *Glycine max* Merr., leaves. *Plant Physiol* **69**: 691–696
- Jayasekera GAU, Reid DM, Yeung EC (1990) Fates of ethanol produced during flooding of sunflower roots. *Can J Bot* **68**: 2408–2414
- Kimmerer TW (1987) Alcohol dehydrogenase and pyruvate decarboxylase activity in leaves and roots of eastern cottonwood (*Populus deltoides* Bartr.) and soybean (*Glycine max* L.). *Plant Physiol* **84**: 1210–1213
- Kimmerer TW, MacDonald RC (1987) Acetaldehyde and ethanol biosynthesis in leaves of plants. *Plant Physiol* **84**: 1204–1209
- Kimmerer TW, Stringer MA (1988) Alcohol dehydrogenase and ethanol in the stems of trees. *Plant Physiol* **87**: 693–697
- Larson PR, Dickson RE (1973) Distribution of imported ¹⁴C in developing leaves of eastern cottonwood according to phyllotaxy. *Planta* **111**: 95–112
- Larson PR, Isebrands JG (1971) The plastochron index as applied to developmental studies of cottonwood. *Can J For Res* **1**: 1–11
- Lehninger AL (1982) *Principles of Biochemistry*. Worth Publishers, New York
- MacDonald RC, Kimmerer TW (1990) Remetabolism of transpired ethanol by *Populus deltoides* (abstract No. 658). *Plant Physiol* **93**: S-112
- MacDonald RC, Kimmerer TW (1991) Ethanol in the stems of trees. *Physiol Plant* **82**: 582–588
- MacDonald RC, Kimmerer TW, Razzaghi M (1989a) Aerobic ethanol production by leaves: evidence for air pollution stress in trees of the Ohio River Valley, USA. *Environ Pollut* **62**: 337–351
- MacDonald RC, Kimmerer TW, Stringer JW (1989b) Remetabolism of transpired ethanol by leaves. IUFRO-ECOPHYS International Workshop: Dynamics of Ecophysiological Processes in Tree Crowns and Forest Canopies
- Oppenheim A, Castelfranco PA (1967) An acetaldehyde dehydrogenase from germinating seeds. *Plant Physiol* **42**: 125–132
- Reckman U, Sheibe R, Raschke K (1990) Rubisco activity in guard cells compared with the solute requirement for stomatal opening. *Plant Physiol* **92**: 246–253
- Stringer JW, Kimmerer TW (1990) Transport and use of CO₂ in the xylem sap of *Populus deltoides* (abstract No. 741). *Plant Physiol* **93**: S-126
- Williamson JR, Tischler M (1979) Ethanol metabolism in perfused liver and isolated hepatocytes with associated methodologies. In E Majchrowicz, EP Noble, eds, *Biochemistry and Pharmacology of Ethanol*, Vol 1. Plenum Press, New York, pp 167–189