

## Linkage Analysis of Families with Fragile-X Mental Retardation, Using a Novel RFLP Marker (DXS 304)

N. Dahl,\* P. Goonewardena,\* H. Malmgren,\* K.-H. Gustavson,† G. Holmgren,‡  
E. Seemanova,§ G. Annerén,† A. Flood,|| and U. Pettersson\*

\*Department of Medical Genetics, Biomedical Center, University of Uppsala, and †Department of Clinical Genetics, University Hospital, Uppsala; ‡Department of Clinical Genetics, University Hospital, Umeå, Sweden; §Department of Medical Genetics, Charles University, Prague; and ||Department of Pediatrics, County Hospital, Hagfors, Sweden

### Summary

A new polymorphic DNA marker U6.2, defining the locus DXS304, was recently isolated and mapped to the Xq27 region of the X chromosome. In the previous communication we describe a linkage study encompassing 16 fragile-X families and using U6.2 and five previously described polymorphic markers at Xq26-q28. One recombination event was observed between DXS304 and the fragile-X locus in 36 informative meioses. Combined with information from other reports, our results suggest the following order of the examined loci on Xq: cen-F9-DXS105-DXS98-FRAXA-DXS304-(DXS52-F8-DXS15). The locus DXS304 is closely linked to FRAXA, giving a peak lod score of 5.86 at a corresponding recombination fraction of .00. On the basis of the present results, it is apparent that U6.2 is a useful probe for carrier and prenatal diagnosis in fragile-X families.

### Introduction

The fragile-X [fra(X)] syndrome is a common X-linked form of mental retardation, and estimates put the frequency at approximately 1/1,000–1/2,000 males (Gustavson et al. 1986; Turner et al. 1986; Webb et al. 1986). Males with the fra(X) syndrome exhibit a wide range of intellectual handicaps, ranging from learning disabilities to profound retardation, with the majority of patients showing moderate to severe retardation (Prouty et al. 1988). A characteristic facial appearance includes a high forehead, prognathism, and protruding ears. Macroorchidism is detected in approximately 80% of the males and is most consistently found during and after puberty. The majority of carrier females are normal, although some suffer from mild mental retardation and/or learning disabilities (Prouty et al. 1988; Thibodeau et al. 1988). The severity of the disease in females appears to be related to the fraction of lympho-

cytes expressing the fragile site on the X chromosome. Diagnosis of carriers, based on the presence of a fragile site at Xq27, is unreliable, since only about 50% of mentally unimpaired, obligate carrier females are found to be positive on cytogenetic testing (Sherman et al. 1984, 1985). Furthermore, only 40% of the sons of obligate carriers are affected in fra(X) families, implying that the penetrance of fra(X) is 80% in males (Sherman et al. 1984, 1985).

There is thus a need for a diagnostic test based on closely linked DNA markers, as a complement to cytogenetic methods, to improve carrier detection and prenatal diagnosis and also for studies aimed at the isolation of the gene that causes the disease. In the present paper we describe linkage data derived from 16 families and utilizing both a new polymorphic marker U6.2 (Dahl et al., in press-a, in press-b) and five previously described flanking markers (table 1). Our results indicate that the marker U6.2, identifying the locus DXS304, is more closely linked to FRAXA than is any other hitherto described probe.

### Material and Methods

Sixteen families with several members showing the

Received March 3, 1989; revision received April 13, 1989.

Address for correspondence and reprints: Ulf Pettersson, M.D., Department of Medical Genetics, Biomedical Center, Box 589, S-751 23 Uppsala, Sweden.

© 1989 by The American Society of Human Genetics. All rights reserved. 0002-9297/89/4502-0013\$02.00

**Table 1**

**Number of Informative Meioses and Number of Recombinations Scored at Various Loci**

Linkage Group	No. of Informative Families	No. of Informative Meioses	No. of Recombinations
FRAXA-F9 . . . . .	9	32	7
FRAXA-DXS105 . . .	5	20	2
FRAXA-DXS304 . . .	11	36	1
FRAXA-F8 . . . . .	6	26	4
FRAXA-DXS52 . . . .	14	60	9
FRAXA-DXS15 . . . .	8	25	3

fragile site on their X chromosomes have been studied. Males were considered to be negative if no more than 1/100 cells showed the abnormality; for females 2/100 cells was used as the limit. Lod scores were computed using the LIPED computer program (Ott 1974, version 1987). A penetrance correction for lod score calculation was used with a penetrance factor of .55 for females and .80 for males. Total genomic DNA was extracted from human leukocytes, digested to completion, fractionated by gel electrophoresis on 0.9% agarose gels, and blotted onto nylon membranes (Pall Biodyne, Bio-Support Division, New York) by Southern transfer (Southern 1975). After being labeled by random priming (Multiprime, Amersham), the probes were hybridized to the filters, and autoradiograms were prepared. The following eight probes were used to detect RFLPs: F9, from the coagulation factor IX locus (Camerino et al. 1983) which detects a *TaqI* RFLP; cX38.1, from the locus DXS102 which detects a *TaqI* RFLP (Arveiler et al. 1988); 4D-8, from locus DXS98 which detects an *MspI* RFLP (Boggs and Nussbaum 1984); cX55.7, from locus DXS105 which detects a *TaqI* RFLP (Veene-ma et al. 1987); F8, from the coagulation factor VIII locus (Gitschier et al. 1985) which detects a *BclI* RFLP; St14, from locus DXS52 (Oberlé et al. 1986) which detects a highly polymorphic *TaqI* RFLP; and DX13, from locus DXS15 (Davies et al. 1985) which detects a *BglIII* RFLP. The probe 4D-8 from the locus DXS98 was found to be informative in only one carrier female investigated (fig. 2), and the probe cX38.1 from the locus DXS102 was only used in a single family to define the haplotypes (fig. 1). No lod score calculations were made that included these two markers, owing to a low number of informative meioses. The marker U6.2 from the locus DXS304 detects six different polymorphisms using any one of the enzymes *BclI*, *BglII*, *MspI*, *PstI*, and

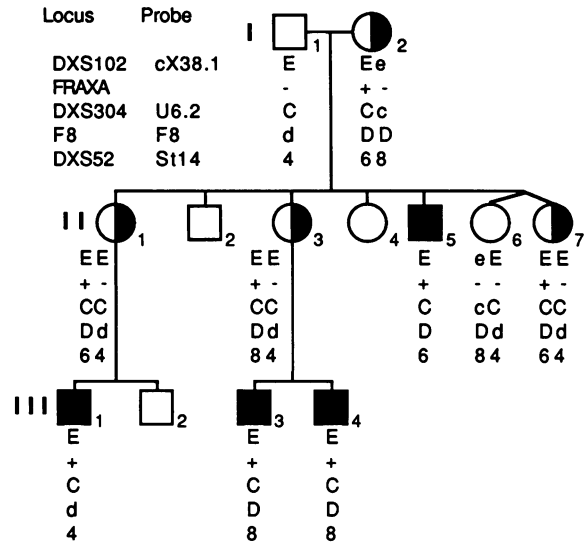

**Figure 1** Part of a family exhibiting recombination events between FRAXA, on one hand, and DXS52 and F8, on the other. II:3 inherited FRAXA and DXS304 alleles from one of the X chromosomes of I:2 and inherited the DXS52 allele from the other X chromosome. In III:1 recombination has occurred between FRAXA, on one hand, and F8 and DXS52, on the other. It is not clear on which side of DXS304 recombination took place, since II:1 is uninformative for U6.2. Filled symbols denote fragile X-positive and mentally retarded individuals; half-filled symbols denote fragile X-positive, mentally normal individuals.

*TaqI* (Dahl et al., in press-b). Only the *TaqI* polymorphism was used, as the different RFLPs are in complete linkage disequilibrium.

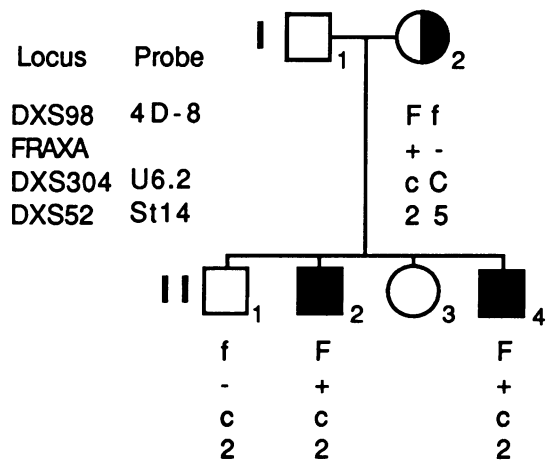

**Figure 2** Kindred segregating for the fragile-X syndrome. In individual II:1, a recombination event is likely to have occurred between DXS304 and FRAXA. DXS98, proximal to FRAXA, and FRAXA cosegregate, whereas DXS304 and DXS52 have recombined with the disease locus. For explanation of symbols, see legend to fig. 1.

**Results**

The marker U6.2 was isolated and characterized as described elsewhere (Dahl et al., in press-a). It was calculated that approximately 30% within a Swedish female population were heterozygous for the U6.2 marker.

The 16 families in the present study belong to 2–4-generation pedigrees. The number of families informative for each locus was as follows: 9 for F9, 5 for DXS105, 11 for DXS304, 6 for F8, 14 for DXS52, and 8 for DXS15. Table 1 shows the total number of informative meioses and the total number of recombination events scored. Only offspring of obligate carriers were scored for the presence or absence of a recombination event. A two-point linkage study, including all possible pairs of loci, was performed using the LIPED program (Ott 1974, version 1987), and the results are presented in table 2. The relative order of the loci F9, DXS105, DXS52 and DXS15 has been defined in earlier studies (Arveiler et al. 1988; Brown et al. 1988). For F8, also used in the present study, contradictory reports have appeared, suggesting a location either prox-

imal to DXS52 (Tantravahi et al. 1986; Bhattacharaya et al. 1987; Patterson et al. 1988b) or distal to DXS52 (Mulligan et al. 1987). Between the locus DXS304 and the fragile-X locus one recombination event was observed among 36 informative meioses, and a peak lod score ( $Z_{max}$ ) of 5.86 was calculated (peak recombination fraction [ $\theta_{max}$ ] = 0.00). A confidence interval (95% confidence limit) of .00–.08 was estimated at a lod score 1.0 below the peak value (Conneally et al. 1985). Recombination events were also observed between FRAXA and all other markers used for lod score calculations in the present study. The F9 locus has been reported to lie proximal to the fragile site with a significant linkage heterogeneity (Brown et al. 1988). Of the set of families analyzed in the present study, some showed an apparent lack of recombination between FRAXA and F9, whereas in others a variable frequency of recombination events was recorded. A total of seven recombination events was scored in five families (table 2). Three of these were observed in a single family, supporting the notion that linkage heterogeneity exists between FRAXA and F9. In one of the families two recom-

**Table 2**  
**Recombination Fraction ( $\theta$ ) Values and Lod Scores ( $Z$ ) for Two-Point Crosses from 16 Fragile X Families, with Cumulative Lod Scores for Each Linkage Group**

LINKAGE GROUP	$\theta$							$\hat{Z}$	$\hat{\theta}$
	.00	.001	.05	.10	.20	.30	.40		
FRAXA-F9	-4.13	-2.92	-.03	.32	.40	.25	.09	.57	.15
FRAXA-DXS105	2.47	2.46	2.21	1.93	1.34	.76	.28	2.47	.00
FRAXA-DXS304	5.86	5.85	5.27	4.65	3.38	2.08	.86	5.86	.00
FRAXA-F8	.11	.31	1.35	1.45	1.23	.81	.36	1.45	.10
FRAXA-DXS52	-1.44	-.27	-2.69	3.11	2.90	2.04	.95	3.16	.13
FRAXA-DXS15	-5.24	-2.42	.77	1.22	1.27	.93	.48	1.33	.15
F9-DXS105	3.56	3.52	3.42	3.16	2.49	1.67	.76	3.56	.00
F9-DXS304	$-\infty$	-2.01	-.38	-.16	-.01	.03	.02	.03	.33
F9-F8	$-\infty$	-5.62	-.77	-.14	.20	.15	.01	.21	.23
F9-DXS52	$-\infty$	-16.87	-4.05	-1.80	-.36	.03	.02	.05	.34
F9-DXS15	$-\infty$	-4.50	-1.18	-.67	-.25	-.09	-.02	.00	.50
DXS105DXS304	-4.31	-2.59	-.79	-.46	-.21	-.11	-.06	.00	.50
DXS105-F8	$-\infty$	-3.31	-.12	.25	.35	.18	.00	.36	.17
DXS105-DXS52	$-\infty$	-16.43	-4.47	-2.46	-.80	-.24	-.05	.00	.50
DXS105-DXS15	.58	.57	.51	.45	.32	.20	.09	.58	.00
DXS304-F8	.00	.00	.00	.00	.00	.00	.00	.00	.50
DXS304-DXS52	$-\infty$	-3.14	1.49	1.92	1.83	1.20	.63	1.97	.14
DXS304-DXS15	$-\infty$	-2.40	.75	1.09	1.12	.84	.43	1.16	.15
F8-DXS52	$-\infty$	7.56	8.45	7.89	6.30	3.78	2.13	8.57	.03
F8-DXS15	4.71	4.70	4.38	4.00	3.14	2.14	1.04	4.70	.00
DXS52-DXS15	$-\infty$	3.15	5.80	5.60	4.52	3.10	1.54	5.80	.06

NOTE.— A confidence interval (95% confidence limit) of .00–.08 was calculated for the linkage group FRAXA-DXS304 at a lod score 1.0 lower than the peak value (Conneally et al. 1985).

bination events were observed between FRAXA, on one hand, and F9 and DXS105, on the other, as described elsewhere (Dahl et al., in press). In this family DXS304 cosegregated with FRAXA. Since F9 and DXS105 are known to be located proximal to FRAXA (Veenema et al. 1987; Arveiler et al. 1988), this result suggests that DXS304 is located distal to these two markers. Two-point linkage analysis for the loci F9-DXS304 gave a  $Z_{\max}$  of 0.03 at  $\theta_{\max} = .33$ , indicating a considerable genetic distance between the two loci in our material. For the linkage DXS304-DXS105 a  $Z_{\max} = 0.5$  was found for  $\theta_{\max} = 0.00$ . The estimated distance between DXS304 and DXS105 is, obviously, unreliable, owing to a small number of meioses, informative at both these loci. The locus DXS52, tightly linked to the F8 locus (Antonarakis et al. 1987), recombined with DXS304 in four of our families. Four recombinations were scored in 20 meioses, informative for DXS52 and DXS304, and a  $Z_{\max}$  of 1.97 was calculated at  $\theta_{\max} = 0.14$  for linkage between these two markers. In one family, represented in figure 1, two recombination events have occurred between DXS52 and FRAXA (II:3 and III:1), and one of these events (that in III:1) also involves F8. DXS304 cosegregates with FRAXA in II:3, suggesting a location proximal to DXS52. In another family three recombination events were observed between DXS52 and FRAXA. The disease locus and DXS304 did cosegregate also in these cases. These results suggest the order Xqcen-(FRAXA, DXS304)-DXS52. Since the genetic distance between DXS52 and FRAXA has been estimated to be 12.7 cM (Brown et al. 1988) and since DXS304 maps proximal to DXS52 at a genetic distance of 14 cM, our results suggest that DXS304 is located close to the FRAXA locus.

One recombination event was observed between DXS304 and FRAXA (II:1 in fig. 2). DXS98, located proximal to FRAXA, cosegregated with the disease gene in this family, whereas both DXS304 and DXS52 recombine with FRAXA. These observations suggest that DXS304 is located distal to FRAXA.

In three families recombination events were seen between F8 and FRAXA, and a  $Z_{\max}$  of 1.45 was calculated at  $\theta_{\max} = 0.10$  (table 2).

F8, which Antonarakis et al. (1987) located at a genetic distance of 3–5 cM from DXS52 and which our material located at a distance of 3 cM ( $Z_{\max} = 8.57$ ), was not informative together with DXS304 in any of the families studied; and the relative positions of F8 and DXS304 could therefore not be ascertained. However, since the distance between DXS304 and DXS52 was estimated to be 14 cM, DXS304 is likely

to be proximal to F8, regardless of the relative positions of F8 and DXS52, as it is more closely linked to FRAXA ( $Z_{\max} = 5.86$  at  $\theta_{\max} = 0.00$ ) than is F8 ( $Z_{\max} = 1.45$  at  $\theta_{\max} = 0.10$ ).

Three recombination events were recorded between FRAXA and the locus DXS15, located distal to DXS52. The recombinations scored between DXS15 and FRAXA also involved recombinations between DXS52 and FRAXA, which was expected, since DXS15 and DXS52 are located less than 65 kb from each other (Patterson et al. 1988b). A  $Z_{\max}$  of 1.16 was calculated at  $\theta_{\max} = 0.15$  for linkage between the loci DXS15 and DXS304. The marker 4D-8, defining the locus DXS98, was informative in only one carrier female, and no lod score was calculated (fig. 2). Similarly, no lod score was calculated for cX38.1 (DXS102), used only in one family to define the haplotype (fig. 1).

Combined with results from other studies our results suggest the order F9-DXS105-DXS98-FRAXA-DXS304-(F8-DXS15-DXS52).

## Discussion

The fra(X) syndrome differs from classic X-linked recessive disorders in several ways. Some males who inherit the mutation lack clinical manifestations and are cytogenetically normal. Furthermore, clinical signs in females are considerably more frequent than they are in typical X-linked recessive disorders (Sherman et al. 1984, 1985). RFLP-based methods, using polymorphic DNA markers that are closely linked to the FRAXA locus, have provided new means to diagnose the mutation in fra(X) families. All the markers shown in tables 1 and 2, with the exception of DXS304, have been used previously in several family studies of the fra(X) syndrome (Oberlé et al. 1986, 1987; Veenema et al. 1987; Arveiler et al. 1988; Brown et al. 1987, 1988; Mulley et al. 1988; Patterson et al. 1988a; Thibodeau et al. 1988). The data summarized in table 1 show that recombinations frequently occur between the FRAXA locus and the other previously used markers F9 (7/32), F8 (4/26), DXS52 (9/60), and DXS 15 (3/25). For DXS304 a single recombination event was observed among 36 informative meioses.

The distances between the FRAXA locus and the other five markers were also estimated, using two-point analysis. The estimates obtained (table 1) were in good agreement with those reported in other studies for the markers F9, F8, St14, and DX13 (Oberlé et al. 1987; Arveiler et al. 1988; Brown et al. 1988; Thibodeau et al. 1988), although the lod scores were comparatively

low in some cases (table 2). DXS105 and FRAXA ( $\theta_{\max} = 0.00$ ) showed a linkage slightly tighter than expected, although the lod score was modest, presumably owing to a small number of informative carriers; only two recombinations were observed among 20 informative meioses.

By combining our results with those from other reports, we propose the following order for markers at Xq26-q28: Xcen-F9-DXS105-DXS98-FRAXA-DXS304-(F8, DXS15, DXS52). Further investigations are needed to obtain a more precise estimate for the genetic distance between DXS304 and FRAXA, as well as to confirm their relative positions.

The probe U6.2 should thus be useful for carrier and prenatal diagnosis in fra(X) families. Owing to its tight linkage to the FRAXA locus, it might also be used as a starting point in attempts to isolate the fra(X) gene.

## Acknowledgments

We thank Elsy Johnsen for technical assistance and Dr. H. E. B. Larson for statistical calculations. We thank the following investigators who agreed to share X chromosome markers: J. L. Mandel, P. L. Pearson, G. Brownlee, K. E. Davies, and L. M. Lawn. Financial assistance for this project was provided by grants from Sävstaholms Society, the Swedish Medical Research Council, the Bank of Sweden Tercentenary Foundation, the Marcus Borgström Foundation, and Pharmacia.

## References

- Antonarakis SE, Youssoufian H, Kazazian HH Jr (1987) Molecular genetics of hemophilia A in man (Factor VIII deficiency). *Mol Biol Med* 4:81-94
- Arveiler B, Oberlé I, Vincent A, Hofker MH, Pearson PL, Mandel JL (1988) Genetic mapping of the Xq27-q28 region: new RFLP markers useful for diagnostic applications in fragile-X and hemophilia-B families. *Am J Hum Genet* 42:380-389
- Bhattacharaya SS, Ludlam CA, Clayton JF, Strain L, Watson H (1987) Haemophilia A, F8C, DXS215 and DXS52; establishment of order and evidence for a familial predisposition to crossover. *Cytogenet Cell Genet* 46:580
- Boggs BA, Nussbaum RL (1984) Two anonymous X-specific human sequences detecting restriction fragment length polymorphisms in region Xq26-qter. *Somatic Cell Mol Genet* 10:607-613
- Brown WT, Wu Y, Gross AC, Chan CB, Dobkins CS, Jenkins EC (1987) RFLP for linkage of fragile X syndrome. *Lancet* 1:280
- Brown WT, Gross A, Chan C, Jenkins EC, Mandel JL, Oberlé J, Arveiler B, et al (1988) Multilocus analysis of the fragile X syndrome. *Hum Genet* 78:201-205
- Camerino G, Mattei MG, Mattei JF, Jaye M, Mandel JL (1983) Close linkage of the fragile X linked mental retardation syndrome to haemophilia B and transmission through a normal male. *Nature* 306:701-707
- Conneally PM, Edwards JH, Kidd KK, Lalouel JM, Morton NE, Ott J, White R (1985) Report of the Committee on Methods of Linkage Analysis and Reporting. *Cytogenet Cell Genet* 40:356-359
- Dahl N, Hammarström-Heeroma K, Goonewardena P, Wadelius C, Gustavson KH, Holmgren G, van Ommen GJB, et al. Isolation of a DNA probe of potential use for diagnosis of the fragile-X syndrome. *Hum Genet* (in press-a)
- Dahl N, Hammarström-Heeroma K, van Ommen GB, Pettersson U. A polymorphic locus at Xq27-28 detected by the probe U6.2 (DXS304). *Nucleic Acids Res* (in press-b)
- Davies K, Mattei MG, Mattei JF, Veenema H, McGlade S, Harper K, Tommerup N, et al. (1985) Linkage studies of X-linked mental retardation: high frequency of recombination in the telomeric region of the human X chromosome. *Hum Genet* 70:249-255
- Gitschier J, Drayna D, Tuddenham EGD, White R, Lawn RM (1985) Genetic mapping and diagnosis of hemophilia A achieved through a Bell polymorphism in the factor VIII gene. *Nature* 314:738-740
- Gustavson KH, Blomquist-K:son H, Holmgren G (1986) Prevalence of the fragile X syndrome in mentally retarded boys in a Swedish county. *Am J Med Genet* 23:581-588
- Mulley J, Turner G, Bain S, Sutherland GR (1988) Linkage between the fragile-X and F9, DXS52 (St14), DXS98 (4D-8) and DXS105 (cX55-7). *Am J Med Genet* 30:567-580
- Mulligan LM, Grover HJ, Blancette VS, Giles AR, Lilliecrap DP, Phillips MA, Holden JJA, et al. (1987) Recombination between the factor VIII gene and the DXS52 locus gives the most probable genetic order as centromere-fra(X)-DXS15-DXS52-F8c-telomere. *Am J Med Genet* 26:751-760
- Oberlé I, Camerino G, Wrogemann K, Arveiler B, Hanauer A, Raimondi E, Mandel JL (1987) Multipoint genetic mapping of the Xq26-q28 region in families with fragile X mental retardation and in normal families reveals tight linkage of markers in q26-q27. *Hum Genet* 77:60-65
- Oberlé I, Heilig R, Moisan JP, Cloepfer C, Mattei MG, Mattei JF, Boué J, et al (1986) Genetic analysis of the fragile-X mental retardation syndrome with two flanking polymorphic markers. *Proc Natl Acad Sci USA* 83:1016-1020
- Ott J (1974) Estimation of the recombination fraction in human pedigrees: efficient computation of the likelihood for human linkage studies. *Am J Hum Genet* 26:588-597
- Patterson M, Bell M, Kress W, Davies KE, Froster-Iskenius U (1988a) Linkage studies in a large fragile X family. *Am J Hum Genet* 43:684-688
- Patterson M, Schwartz C, Bell M, Sauer S, Hofker M, Trask B, van den Engh G, et al (1988b) Physical mapping studies

- on the human X chromosome in the region Xq27-Xqter. *Genomics* 1:297-306
- Prouty LA, Rogers RC, Stevenson RE, Dean JH, Palmer KK, Simensen RJ, Coston GN, et al (1988) Fragile X syndrome: growth, development, and intellectual function. *Am J Med Genet* 30:123-142
- Sherman SL, Jacobs PA, Morton NE, Froster-Iskenius U, Howard-Peebles PN, Nielsen KB, Partington MW, et al. (1985) Further segregation analysis of the fragile x syndrome with special reference to transmitting males. *Hum Genet* 69:289-299
- Sherman SL, Morton NE, Jacobs PA, Turner G (1984) The marker (X) syndrome: a cytogenetic and genetic analysis. *Ann Hum Genet* 48:21-37
- Southern EM (1975) Detection of specific sequences among DNA fragments separated by gel electrophoresis. *J Mol Biol* 98:503-517
- Tantravahi U, Murty VVVS, Jhanvar SC, Toole JJ, Woozney JM, Chaganti RSK, Latt S (1986) Physical mapping of the factor VIII gene proximal to two polymorphic DNA probes in human chromosome band Xq28: implications for factor VIII gene segregation analysis. *Cytogenet Cell Genet* 42:75-79
- Thibodeau SN, Dorkins HR, Faulk KR, Berry R, Smith ACM, Hagerman R, King A, et al (1988) Linkage analysis using multiple DNA polymorphic markers in normal families and in families with fragile X syndrome. *Hum Genet* 79:219-227
- Turner G, Robinson GH, Laing S, Purvis-Smith S (1986) Preventive screening for the fragile X syndrome. *N Engl J Med* 315:607-609
- Veenema H, Carpenter NJ, Bakker E, Hofker MH, Millington-Ward A, Pearson PL (1987) The fragile X syndrome in a large family. III. Investigations on linkage of flanking DNA markers with the fragile site Xq27. *J Med Genet* 24:413-421
- Webb TP, Bunday SE, Thake AI, Todd J (1986) Population incidence and population and segregation ratios in Martin-Bell syndrome. *Am J Hum Genet* 23:573-580