

## **Multifactorial Inheritance with Cultural Transmission and Assortative Mating**

### **II. A General Model of Combined Polygenic and Cultural Inheritance**

C. ROBERT CLONINGER,<sup>1</sup> JOHN RICE, AND THEODORE REICH

#### SUMMARY

A general linear model of combined polygenic-cultural inheritance is described. The model allows for phenotypic assortative mating, common environment, maternal and paternal effects, and genic-cultural correlation. General formulae for phenotypic correlation between family members in extended pedigrees are given for both primary and secondary assortative mating.

A FORTRAN program BETA, available upon request, is used to provide maximum likelihood estimates of the parameters from reported correlations. American data about IQ and Burks' culture index are analyzed. Both cultural and genetic components of phenotypic variance are observed to make significant and substantial contributions to familial resemblance in IQ. The correlation between the environments of DZ twins is found to equal that of singleton sibs, not that of MZ twins. Burks' culture index is found to be an imperfect measure of midparent IQ rather than an index of home environment as previously assumed.

Conditions under which the parameters of the model may be uniquely and precisely estimated are discussed. Interpretation of variance components in the presence of assortative mating and genic-cultural covariance is reviewed. A conservative, but robust, approach to the use of environmental indices is described.

---

Received April 26, 1978; revised November 3, 1978.

This research was supported in part by U.S. Public Health Service grants AA-00209, AA-03539, MH-14677, and MH-25430, and Research Scientist Development Award MH-00048 to Dr. Cloninger.

<sup>1</sup> All authors: Department of Psychiatry, Washington University School of Medicine, and the Jewish Hospital of St. Louis, 216 South Kingshighway, St. Louis, Missouri 63110.

## INTRODUCTION

Surprisingly, the combined effects of both polygenic and cultural inheritance have not been systematically described for pedigrees extending over several generations. This is unfortunate because simpler models appear inadequate to account for available knowledge about the familial transmission of complex developmental phenomena like height, intelligence, or behavioral traits. Unitary models, as previously described [1], are particularly useful when data are available about only a few classes of relatives reared in intact families, but they can only approximate familial resemblance when parents transmit genetic and cultural influences to different degrees. Recognition of the fundamental importance of more general multifactorial models was demonstrated early in the pioneering work of Sewall Wright [2] on intelligence in 1931. There has been a recent resurgence of interest in cultural inheritance [3, 4, 5, 6, 7], and this has been reviewed in part elsewhere by Li [8] and by Morton and Rao [9].

In this paper we use path analysis to develop a linear model of familial resemblance in extended pedigrees which distinguishes between the influences of polygenes, sociocultural factors transmitted from parent to offspring, and other environmental influences. The major variables (causes and effects, symbolized by capital English letters) and path coefficients (symbolized by lower case letters) are summarized and described in tables 1 and 2 respectively. Genetic and non-genetic factors are assumed to be additive. Correlations between factors are considered systematically including assortative mating, genic-cultural correlation, and correlated home environments. Departures from linearity (dominance, epistasis, and gene-environment interaction) are neglected. The emphasis of the model is on the resolution and quantification of both genetic and cultural factors simultaneously. In particular, we wish to explore the conditions, if any, under which the parameters of the model are uniquely and precisely determined in intact families. The definitions of the cultural and environmental variables were chosen to facilitate the description of extended pedigrees, and to clarify the varying and vague formulations of relevant non-genetic influences employed in prior work.

The fundamental distinction made here among non-genetic factors is whether or not sociocultural and environmental factors are transmitted between generations (i.e., from parent-of-rearing to child-of-rearing). Transmission of sociocultural factors (symbol-

TABLE 1  
MAJOR VARIABLES OF THE GENERAL MODEL

Variables	Observable Index	Description
<i>P</i> .....	$I_P$	Phenotype
<i>A</i> .....	None	Additive polygenic factors
<i>S</i> .....	None	Segregation from mid-parent genotype
<i>B</i> .....	$I_B$	Sociocultural factors transmitted between generations
<i>F</i> .....	None	Within family variation of transmissible sociocultural values
<i>E</i> .....	$I_E$	Environmental experiences relevant to developing the phenotype but not transmitted between generations

TABLE 2  
PATH COEFFICIENTS AND CORRELATION COEFFICIENTS OF THE GENERAL MODEL

Symbols	Description
$h$ or $\sigma_A/\sigma_P$ .....	Extent to which additive genetic factors influence phenotype
$b$ or $\sigma_B/\sigma_P$ .....	Extent to which transmissible sociocultural factors influence phenotype
$e^*$ or $\sigma_E/\sigma_P$ .....	Extent to which non-transmissible environment influences phenotype
$w^\dagger$ .....	Correlation between genetic and cultural values within individuals
$c$ .....	Correlation between non-transmissible environments of sibs or other contemporaneous family members living together
$m$ .....	Correlation between the phenotypes of mates
$\beta$ .....	Extent to which children inherit cultural values of parents
$t^*$ .....	Extent to which all transmissible factors influence phenotype
$i$ .....	Extent to which non-transmissible environment is graded or observed
$p$ .....	Extent to which true phenotype is observed
$s^*$ .....	Extent of segregation from mid-parent genotype
$f^*$ .....	Extent of variation from mid-parent cultural values

\* May be derived from other parameters.

† May be primary correlation or, if due to assortative mating, derived.

ized by  $B$ ) from one generation to the next (cultural inheritance) may be learned or acquired when parents teach their offspring certain customs and preferences about diet, environment, social climate, and other activities which distinguish different families [4]. Cultural inheritance may have *indirect* effects on a wide variety of traits which are affected by milieu, diet, or other cultural-ecological influences; or it may have *direct* effects on other phenotypes via social learning or modeling, especially behavioral, psychiatric, or "developmental" traits. In principle, an index of sociocultural influences ( $I_B$ ) can be developed, but for direct cultural inheritance, such attempts may be difficult if not impossible, because the processes of teaching and learning are so complex that they cannot be assessed independently. Other problems of environmental indices and alternative approaches to the estimation of effects will be discussed later in this paper.

Other environmental factors which are relevant (i.e., which influence the development of the trait) are denoted here as non-transmissible environment ( $E$ ). By definition, the parent's  $E$  does not influence the child's  $E$ , but the environmental values of relatives *within* a given generation (e.g., sibs) may be correlated. The correlation between the environmental values (denoted as  $c$ ) refers to environmental influences which are not transmitted *between* generations, but which are shared by family members reared together or contemporaneously. Such correlated environmental experiences include all the relevant characteristics of the home, neighborhood, schools, and other aspects of the ecology which are peculiar to a particular family at a particular time and locale. This definition is similar to that of "common environment" as described by Morton [10] and Li [11], except that in previous work the distinction between those non-genetic factors which are inherited and those non-genetic factors due to temporal or geographic coincidence has been blurred. Failure to make this fundamental difference explicit has little consequence when attention is restricted to nuclear families, but in extended pedigrees it is crucial that the distinction be consistently maintained, as is done here.

Treatment of gene-environment correlation and assortative mating in the presence of combined polygenic and cultural inheritance has received limited attention in the past. Fisher's [12] work deals only with polygenic inheritance. Morton and Rao [9], Rao et al. [6], and Li [8] have described the effects of secondary assortative mating due to social homogamy (i.e., the tendency to marry within a social class). Sewall Wright [2, 13] has described some effects of primary assortative mating in the presence of cultural inheritance. In this paper, we introduce a primary correlation between the phenotypes of mates ( $m$ ) which may be positive (i.e., direct homogamy in which like individuals preferentially mate) or negative (unlike individuals preferentially mate). In estimating the correlation between mates, secular trends and non-familial socioeconomic influences should be considered, as Cavalli-Sforza and Bodmer have noted [14]. Such direct homogamy appears important for many behavioral traits and personality measures [15, 16]. Accordingly, description of the effects of direct homogamy in combined genetic-cultural models of familial resemblance is overdue.

In this paper we assume that all individuals have been reared in intact nuclear families by both biological parents in order to simplify the description of the properties of the model. The important effects of family structure and separation experiences will be considered in detail elsewhere [17].

#### *Assumptions and General Properties of the Model*

The following nine points define the General Multifactorial Model and are consistent with prior formulations of unitary multifactorial models [1].

1. Genetic factors ( $A$ ) are multiple and strictly additive, each having a small effect relative to the total genetic variance ( $V_A$ ). Accordingly,  $A$  is taken to be a normal variate, and departures from linearity (e.g., dominance and epistasis) are neglected.

2. Heritable cultural factors ( $B$ ) are also multiple and additive, each having a small effect relative to the total cultural variance ( $V_B$ ). Therefore,  $B$  is also a normal variate, and departures from linearity are neglected.

3. The joint distribution of the immediate causes of the phenotype  $P$  (viz.,  $A$ ,  $B$ , and  $E$ ) is assumed to be trivariate normal. It follows from this that  $P$  is also normally distributed [18]. Then phenotype may be partitioned according to the standardized regression equation,

$$P = \frac{\sigma_A}{\sigma_P} A + \frac{\sigma_B}{\sigma_P} B + \frac{\sigma_E}{\sigma_P} E = hA + bB + eE, \quad (1)$$

where the symbols are defined as stated in tables 1 and 2. Then the phenotypic variance ( $V_P$ ) is given by the expressions

$$\begin{aligned} V_P &= h^2 + b^2 + e^2 + 2whb = 1 & (2) \\ &= t^2 + e^2, & (2.1) \end{aligned}$$

where the total transmissible variance ( $t^2$ ) equals  $(h^2 + b^2 + 2whb)$ ,  $\text{cov}(A, B)$  within individuals =  $whb$ , and  $\text{cov}(A, E) = \text{cov}(B, E) = 0$  by definition.

4. The transmission probability or path coefficient from parents' genic value  $A$  to child's genic value  $A$  is taken as  $1/2$  from biological considerations about the mechanism of diploid autosomal inheritance.

5. The path coefficient from parent's cultural value  $B$  to child's cultural value  $B$  is denoted by  $\beta$ . The requirement that the cultural variance ( $\sigma_B^2$ ) be finite places constraints on the magnitude of  $\beta$ , as previously shown [1]. Accordingly, we assume here that

$$|\beta| \leq 1/\sqrt{2(1+m)} \quad \text{if } m \geq 0, \text{ or } |\beta| \leq 1/\sqrt{2} \text{ if } m \leq 0. \quad (3)$$

If  $\beta_M \neq \beta_F$ , then the corresponding constraint obtained from equation (7, below) is

$$\beta_M^2 + \beta_F^2 + 2m\beta_M\beta_F \leq 1 \quad \text{if } m \geq 0, \text{ or } \beta_M^2 + \beta_F^2 \leq 1 \text{ if } m \leq 0. \quad (3.1)$$

It should be noted that sociocultural factors may lead to parents-of-rearing and children-of-rearing being alike ( $\beta$  positive) or unlike ( $\beta$  negative).

6. Assortative mating, if present, is assumed to be based directly on phenotypic preference. It is further assumed that assortative mating is recurrent and of constant magnitude as measured by the correlation between phenotypes ( $m$ ). This assumption is not restrictive since the approach to equilibrium under assortative mating is rapid, as previously shown [1].

7. Assortative mating is assumed to affect only the variance of transmissible factors. As previously shown [1], it follows that the genic variance due to segregation ( $S$ ) from midparent genic value is

$$s^2V_S = \frac{1}{2}V_{Ao}, \quad (4)$$

where the subscript  $o$  here (and in equations 5–7) denotes the random mating value; and the cultural variance due to fluctuation ( $F$ ) from midparent cultural value is

$$f^2V_F = (1 - \beta_M^2 - \beta_F^2)V_{Bo} \quad (5)$$

where  $\beta_M = \beta$  for mothers, and  $\beta_F = \beta$  for fathers. From similar considerations [1], it follows that at equilibrium under assortative mating:

$$V_A = \frac{V_{Ao}}{1 - r_{AA}} \quad (6)$$

and

$$V_B = \frac{V_{Bo}(1 - \beta_M^2 - \beta_F^2)}{1 - (\beta_M^2 + \beta_F^2 + 2\beta_M\beta_F r_{BB})} \quad (7)$$

where  $r_{AA}$  and  $r_{BB}$  are the correlation between genic values of mates and cultural values of mates, respectively. However, because of the presence of genic-cultural correlation ( $w$ ), the values of  $r_{AA}$  and  $r_{BB}$  are not  $mh^2$  and  $mb^2$  as in the unitary models. The values of  $r_{AA}$  and  $r_{BB}$  will be derived later in equations (15) and (16).

8. We allow for a correlation ( $w$ ) between the genic and cultural values of an individual. Even if the correlation is 0 under random mating, when  $\beta$  is positive, assortative mating leads to a positive correlation, and disassortative mating leads to a negative correlation (and vice versa when  $\beta$  is negative). It should be recalled from path analysis [11, 19, 20] that with correlated causes the coefficients for reversed paths are unequal. Thus in figure 1,

$$\gamma = r_{AP} = h + wb, \quad (8)$$

$$\phi = r_{BP} = b + wh, \quad (9)$$

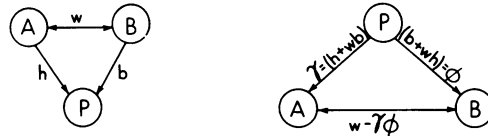

FIG. 1.—Two mutually consistent path diagrams of the relationship between the phenotype ( $P$ ), genic value ( $A$ ), and cultural value ( $B$ ) of the same individual.

and  $w = r_{AB}$  so that the two diagrams are consistent with one another. This inequality of the reversed path coefficients in the presence of genic-cultural correlation requires careful attention in subsequent derivations.

9. It is assumed that each individual is reared in an intact nuclear family, that is, by both biological parents. This assumption may often be unrealistic and is removed in further elaboration of the model [17].

*Parent-Offspring Resemblance*

The path diagram depicting the relationship between parents and offspring is shown in figure 2. Unobserved variables are represented in circles, and observed indices, in squares, following the convention of Rao et al. [6]. Primary paths are represented by solid lines, and redundant paths (i.e., those implied by other paths) are represented by dashed lines, following Li's convention [19]. From figure 2 the correlation between parent's and child's true phenotypes ( $\rho_{io}$ ) is

$$\rho_{io} = \frac{1}{2}(1 + m)h\gamma + (\beta_i + m\beta_j)b\phi \tag{10}$$

$$= \frac{1}{2}(1 + m)(h^2 + whb) + (\beta_i + m\beta_j)(b^2 + whb) \quad , \tag{10.1}$$

where the subscripts  $i$  and  $j$  denote the sex of the parent such that  $i \neq j = M$  (for mother) or  $F$  (for father).

Letting  $\Gamma = h^2 + whb$  , (11)

and  $\Phi = b^2 + whb$  , (12)

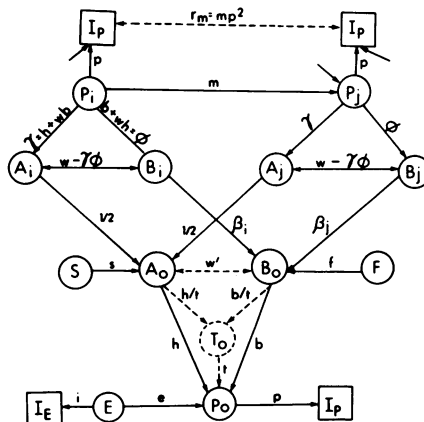

FIG. 2.—Path diagram depicting the causes of phenotypic resemblance between parents ( $P_i$  and  $P_j$ ) and their offspring ( $P_o$ ) in intact nuclear families.

then

$$\rho_{io} = \frac{1}{2}(1 + m)\Gamma + (\beta_i + m\beta_j)\Phi . \quad (10.2)$$

When  $\beta_M = \beta_F = \beta$ ,  $\rho_{MO} = \rho_{FO}$ , and the expression for parent-offspring correlation ( $\rho_{po}$ ) reduces to

$$\rho_{po} = (1 + m) (\frac{1}{2}\Gamma + \beta\Phi) . \quad (10.3)$$

In the special case where  $\beta = 1/2$ ,

$$\rho_{po} = \frac{1}{2}(1 + m) (\Gamma + \Phi) = \frac{1}{2}(1 + m)t^2 , \quad (10.4)$$

since  $\Gamma + \Phi = h^2 + b^2 + 2whb = t^2$ . This confirms the expected identity of the unitary *pseudopolygenic* model [1] and the combined model under the condition that  $\beta = 1/2$ .

Since the true phenotypes are not measured without error, the correlation between the phenotypic indices ( $I_p$ ) of parent-offspring pairs ( $r_{po}$ ) is given by

$$r_{po} = p^2\rho_{po} , \quad (12.1)$$

and the correlation ( $m$ ) between mates in terms of the correlation  $r_m$  between the phenotypic indices of mates is

$$m = r_m/p^2 . \quad (14)$$

#### *Marital and Genic-Cultural Correlations*

From figure 2 the correlations induced between the causes of phenotypes of mates may also be deduced. Thus, the correlation between the genic values of mates ( $r_{AA}$ ) is

$$r_{AA} = m\gamma^2 = m(h + wb)^2 . \quad (15)$$

The correlation between the cultural values of mates ( $r_{BB}$ ) is

$$r_{BB} = m\phi^2 = m(b + wh)^2 , \quad (16)$$

and the correlation between the genic values of an individual with the cultural value of his mate ( $r_{AB}$ ) is

$$r_{AB} = m\gamma\phi = m(h + wb)(b + wh) . \quad (17)$$

Similarly, the correlation between genic and cultural values of an individual may be deduced from figure 2 where  $w$  is due to recurrent assortative mating. Thus,

$$w' = \frac{1}{2}(\beta_M + \beta_F)(w + r_{AB}) . \quad (18)$$

If genic-cultural correlations are due solely to assortative mating, and children are reared in intact homes, the correlation  $w$  between the genic and cultural values of an individual is the same as the correlation between the genic value of any individual with the cultural value of his full sib. This is expected because the genic and the cultural values of any individual are determined discretely of one another (except in circumstances where there are primary causes of genic-cultural correlation, such as in

Lamarckian models), and, given the genic and cultural values of their parents, the pairing of the genic and cultural values of their offspring are independent. This is analogous to Mendel's Law of Independent Segregation.

At equilibrium

$$w' = w, \text{ so } w = \lambda r_{AB} = \lambda m \gamma \phi$$

where

$$\lambda = (\beta_M + \beta_F) / (2 - \beta_M - \beta_F). \tag{18.1}$$

It may be noted that whenever

$$(\beta_M + \beta_F) = 1, \text{ then } \lambda = 1 \text{ and } w = r_{AB}. \tag{18.2}$$

Also  $w$  may be greater or less than  $r_{AB}$  depending on the magnitude of  $\lambda$ . Since  $\gamma\phi$  is positive in equation (18.1), the sign of  $w$  is given by  $\lambda m$ . In general, the value of  $w$  due to recurrent assortative mating may be obtained from equations (17) and (18.1). The value of  $w$  is given by solving the quadratic equation

$$w^2 + w \left[ \frac{\lambda m (h^2 + b^2) - 1}{\lambda m h b} \right] + 1 = 0, \tag{19}$$

and taking the root with absolute value less than unity, and the same sign as the product of  $\lambda$  and the correlation between mates.

*Sibling and Twin Resemblance*

The path diagram depicting the relationship between full sibs is shown in figure 3. The correlation between the true phenotypes of full sibs ( $\rho_{oo}$ ) is

$$\rho_{oo} = \{ \frac{1}{2} h^2 (1 + r_{AA}) + (\beta_M^2 + \beta_F^2 + 2\beta_M\beta_F r_{BB}) b^2 + (\beta_M + \beta_F) (w + r_{AB}) h b + c_s e^2 \}, \tag{20}$$

where  $c_s$  is the correlation between the environments of sibs.

If  $w$  is due solely to assortative mating,  $(w + r_{AB}) = 2w / (\beta_M + \beta_F)$  and

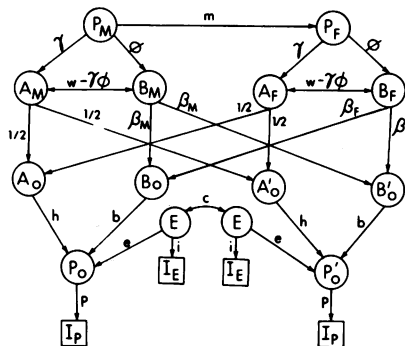

FIG. 3.—Path diagram depicting the causes of phenotypic resemblance between full sibs ( $P_o$  and  $P_o$ ) in intact nuclear families (residuals omitted).



$$\rho_{oo} = \{ \frac{1}{2}h^2(1 + r_{AA}) + (\beta_M^2 + \beta_F^2 + 2\beta_M\beta_F r_{BB})b^2 + 2whb + c_s e^2 \} . \quad (20.1)$$

If  $\beta_M = \beta_F = 1/2$ ,

$$\rho_{oo} = \{ \frac{1}{2}h^2(1 + r_{AA}) + \frac{1}{2}b^2(1 + r_{BB}) + (w + r_{AB})hb + c_s e^2 \} = \frac{1}{2}(1 + m^2)t^2 + c_s e^2 . \quad (20.2)$$

The expressions for twins are similar to that for full sibs except that the correlation between the relevant environments of singleton sibs ( $c_s$ ) and of twins ( $c_{dz}$  and  $c_{mz}$ ) may differ, and MZ twins are genetically identical. In other words,

$$\rho_{DZ} = \{ \frac{1}{2}h^2(1 + r_{AA}) + (\beta_M^2 + \beta_F^2 + 2\beta_M\beta_F r_{BB})b^2 + 2whb + c_{mz} e^2 \} , \quad (21)$$

and

$$\rho_{MZ} = \{ h^2 + (\beta_M^2 + \beta_F^2 + 2\beta_M\beta_F r_{BB})b^2 + 2whb + c_{dz} e^2 \} , \quad (22)$$

where  $w = \frac{1}{2}(\beta_M + \beta_F)(w + r_{AB})$  .

These relationships are most informative when  $c_s = c_{dz} = c_{mz}$ . Because twins are born at the same time, it is often assumed that  $c_s \neq c_{dz} = c_{mz}$ . However, these assumptions must be empirically tested.

*Remote Vertical Relatives*

The path diagram depicting the relationship between grandparent and grandchild is shown in figure 4. Let  $K_2$  denote the sum of all the paths from  $A_k$  to  $P_o$ :

$$K_2 = \frac{1}{2}(1 + mh\gamma)h + (hm\phi\beta_i)b$$

or

$$K_2 = \frac{1}{2}(1 + m\Gamma)h + \beta_i m(hb + wh^2)b . \quad (23)$$

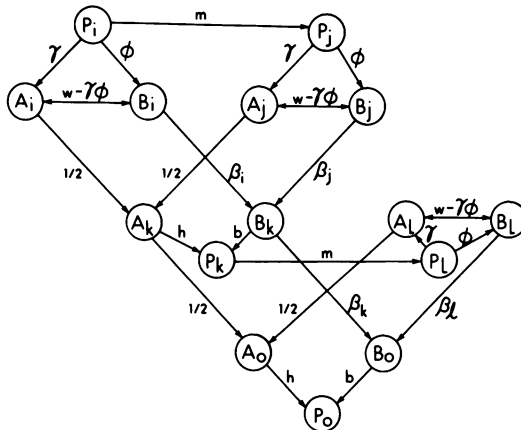

FIG. 4.—Path diagram depicting the causes of phenotypic resemblance among grandparents ( $P_i$  and  $P_j$ ), parents ( $P_k$  and  $P_l$ ), and grandchild ( $P_o$ ).

Also let  $\Lambda_2$  denote the sum of all the paths from  $B_k$  to  $P_o$ :

$$\Lambda_2 = (\beta_k + \beta_l \phi m b) b + (\frac{1}{2} b m \gamma) h ,$$

or

$$\Lambda_2 = (\beta_k + \beta_l \Phi m) b + \frac{1}{2} m (h b + w b^2) h . \quad (24)$$

Then the correlation between one grandparent ( $P_i$ ) and grandchildren ( $P_o$ ) is

$$\rho_{io} = \frac{1}{2} (1 + m) \gamma K_2 + (\beta_i + \beta_j m) \phi \Lambda_2 , \quad (25)$$

where  $i \neq j = M$  or  $F$  and  $k \neq l = M$  or  $F$  .

This may be expanded to give

$$\begin{aligned} \rho_{io} = & \{ \frac{1}{4} (1 + m) (h^2 + w h b) [1 + m (h^2 + w h b)] \\ & + (\beta_i + \beta_j m) (b^2 + w h b) [\beta_k + \beta_l m (b^2 + w h b)] \\ & + \frac{1}{2} \beta_l m (1 + m) (h b + w b^2) (h b + w h^2) \\ & + \frac{1}{2} (\beta_i + m \beta_j) m (h b + w b^2) (h b + w h^2) \} . \end{aligned} \quad (25.1)$$

Recalling that  $\Gamma \Phi = (h^2 + w h b) (b^2 + w h b) = (h b + w h^2) (h b + w b^2)$ , the expression may be symbolized by

$$\begin{aligned} \rho_{io} = & \{ \frac{1}{4} (1 + m) \Gamma (1 + m \Gamma) + (\beta_i + m \beta_j) \Phi (\beta_k + m \beta_l \Phi) \\ & + \frac{1}{2} m \Gamma \Phi [\beta_l (1 + m) + \beta_i + m \beta_j] \} . \end{aligned} \quad (25.2)$$

If  $\beta_M = \beta_F$ , these awkward expressions for the expected correlation between the true phenotypes of grandparent and grandchild ( $\rho_{GO}$ ) reduce to

$$\rho_{GO} = (1 + m) \{ \frac{1}{4} \Gamma (1 + m \Gamma) + \beta^2 \Phi (1 + m \Phi) + \beta m \Gamma \Phi \} , \quad (25.3)$$

and if  $\beta = 1/2$ ,

$$\rho_{GO} = \frac{1}{4} (1 + m) (1 + m t^2) t^2 . \quad (25.4)$$

In general the correlation between vertical relatives (i.e., an ancestor and descendant) separated by  $n$  generations is

$$\rho_{Vn} = \frac{1}{2} (1 + m) \gamma K_n + (\beta_i + m \beta_j) \phi \Lambda_n , \quad (26)$$

where  $n = 1$  for parent/offspring, 2 for grandparent, etc., and  $K_1 = h$  and  $\Lambda_1 = b$ .

For  $n > 1$ ,

$$K_n = \frac{1}{2} (1 + m \Gamma) K_{n-1} + \beta_l m (h b + w h^2) \Lambda_{n-1} , \text{ and} \quad (27)$$

$$\Lambda_n = (\beta_k + m \beta_l \Phi) \Lambda_{n-1} + \frac{1}{2} m (h b + w b^2) K_{n-1} \quad (28)$$

taking care to specify the appropriate sex for  $B_k$  and  $B_l$  in each generation. In equation (26) it should be noted that the sign of the cultural contribution may be negative when  $\beta$  is negative and  $n$  is odd, but is positive in other cases. A negative sign will lead to oscillation in the rate of decline of kinship correlations with increasing generation number. When  $\beta = 1/2$ , these expressions reduce to

$$\rho_{Vn} = (\frac{1}{2})^n (1 + m) (1 + m t^2)^{n-1} t^2 . \quad (26.1)$$

Remote Collateral Relatives

The path diagram depicting the relationship between an individual and his sib's child (i.e., uncle/nephew, aunt/nephew, etc.) is shown in figure 5. If  $\beta_M = \beta_F$ , the correlation ( $\rho_{C2}$ ) depends on the sex of the sib (viz., on  $\beta_k$ ). Thus, the correlation is

$$\rho_{oq} = \rho_{C2} = \{ \frac{1}{2}(1 + r_{AA})hK_2 + (\beta_M^2 + \beta_F^2 + 2\beta_M\beta_F r_{BB})\Lambda_2 b + \frac{1}{2}(\beta_M + \beta_F)(w + r_{AB})[h\Lambda_2 + bK_2] + c_s e^2 m M_2 \} \quad (29)$$

where  $M_2$ , the sum of all the paths from  $P_l$  to  $P_o$ , equals  $(\frac{1}{2}\gamma h + \beta_1 \phi b)$ . (30)

When  $\beta_M = \beta_F = 1/2$ , this reduces to  $\rho_{oq} = \frac{1}{4}(1 + mt^2)t^2$ . Similarly, it can be shown that the correlation between first cousins ( $\rho_{C11}$ ) is

$$\rho_{C11} = \{ \frac{1}{2}(1 + r_{AA})K_2^2 + (\beta_M^2 + \beta_F^2 + 2\beta_M\beta_F r_{BB})\Lambda_2^2 + (\beta_M + \beta_F)(w + r_{AB})[\Lambda_2 K_2] + c_s e^2 m^2 M_2^2 \} . \quad (31)$$

In general, the correlation between an individual and a descendant of his sib is

$$\rho_{Cn} = \frac{1}{2}(1 + r_{AA})hK_n + (\beta_M^2 + \beta_F^2 + 2\beta_M\beta_F r_{BB})b\Lambda_n + w(h\Lambda_n + bK_n) + c_s e^2 m M_n , \quad (32)$$

where  $M_n = [\frac{1}{2}\gamma K_{n-1} + \beta_l \phi \Lambda_{n-1}]$  and  $w = \frac{1}{2}(\beta_M + \beta_F)(w + r_{AB})$ , and  $n$  is an integer denoting the degree of genetic relationship ignoring inbreeding. The correlation between the  $i$ th descendant of one sib and the  $i$ th' descendant of the other sib is

$$\rho_{Cii'} = \{ \frac{1}{2}(1 + r_{AA})K_j K_{j'} + (\beta_M^2 + \beta_F^2 + 2\beta_M\beta_F r_{BB})\Lambda_j \Lambda_{j'} + \frac{1}{2}(\beta_M + \beta_F)(w + r_{AB})(K_j \Lambda_{j'} + K_{j'} \Lambda_j) + c_s e^2 m^2 M_j M_{j'} \} , \quad (33)$$

where  $j = i + 1$  and  $j' = i' + 1$ . When  $\beta = 1/2$ , these expressions reduce to

$$\rho_{Cn} = (\frac{1}{2})^n (1 + mt^2)^n t^2 + (\frac{1}{2})^{n-1} c_s e^2 (mt^2) (1 + mt^2)^{n-2} \quad (32.1)$$

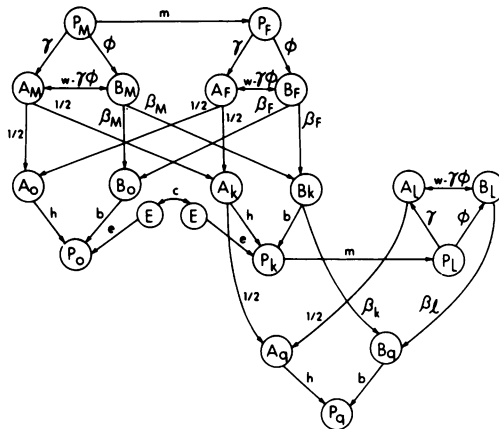

FIG. 5.—Path diagram depicting the causes of phenotypic resemblance between uncle/aunt ( $P_o$ ) and nephew/niece ( $P_q$ ).

and

$$\rho_{Civ} = (\frac{1}{2})^n(1 + mt^2)^nt^2 + (\frac{1}{2})^{n-1}c_s e^2(m^2t^4) (1 + mt^2)^{n-3} . \quad (33.1)$$

Where  $n$ , the degree of genetic relationship as defined above, is given by

$$n = i + i' + 1 = j + j' - 1.$$

#### APPLICATIONS

##### *IQ*

American kinship correlations about IQ test scores have recently been collected by Rao and Morton [21] based largely on the summary by Jencks [22]. Detailed itemization of the individual studies with commentary has been given elsewhere by Goldberger [23], and we follow his enumeration of the correlations despite some trivial discrepancies from the original reports. The data set, summarized in table 3, includes kinships omitting information on environmental indices and distinguishing DZ twins and singleton full sibs.

A FORTRAN program BETA, available upon request, was used to provide maximum likelihood estimates of seven primary parameters:  $m$ ,  $\beta$ ,  $h$ ,  $b$ ,  $c_s$ ,  $c_{dz}$ ,  $c_{mz}$ . Expressions for the expected correlations are summarized for convenience in table 3. General expressions for the four kinships involving separation experiences are derived elsewhere [17], and those used here were obtained assuming random placement and nuclear family structure. From the reported mean correlations and the expected relationships specified by the model, maximum likelihood estimates were obtained using Kaplan and Elston's MAXLIK as previously described for our program TAU [1].

Fitting the seven parameters model to the nine observed mean correlations, a good fit was obtained ( $\chi^2_2 = 3.73$ ,  $.10 < P < .25$ ). Tests of hypotheses involving linear constraints on the seven parameter set were carried out using a likelihood ratio test to determine the most parsimonious parameter set describing the observations acceptably. The hypotheses that  $c_s = 0$  and that  $c_{dz} = c_{mz}$  were rejected ( $\chi^2_1 = 4.77$ ,  $P < 0.05$ ;  $\chi^2_1 = 12.34$ ,  $P < 0.01$  respectively). The hypothesis that  $c_s = c_{dz}$  was acceptable ( $\chi^2_1 = 0.62$ ;  $.25 < P < .50$ ), and this one constraint described the most parsimonious model acceptable.

At the point of best fit ( $\chi^2_3 = 4.35$ ), the parameters of the most parsimonious model are  $m = .490$ ,  $\beta = .444$ ,  $h = .571$ ,  $b = .521$ ,  $c_s = c_{dz} = .351$ , and  $c_{mz} = 1.000$ . The derived genic-cultural correlation  $w$  is  $.156$ . The components of phenotypic variance are  $h^2 = 32.6\%$ ,  $b^2 = 27.2\%$ ,  $2whb = 9.3\%$ , and  $e^2 = 30.9\%$ . The total transmissible variance  $t^2 = 69.1\%$ . The hypothesis that additive genetic variance is negligible was found to be unacceptable ( $\chi^2_1 = 82.37$ ); 95% confidence limits are  $23\% \leq h^2 \leq 41\%$ . The hypothesis that cultural transmission is negligible was also unacceptable ( $\chi^2_1 = 68.38$ ), and confidence limits are  $8\% \leq b^2 \leq 32\%$ . The hypothesis that sibling environments are uncorrelated was unacceptable ( $c_s = c_{dz} = 0$ ,  $\chi^2_1 = 5.22$ ).

The observed correlations and those expected at the point of best fit are compared in table 3. It can be seen that all the observed and expected values are in close agreement except for MZ twins reared apart. This correlation is underpredicted (.68 vs. .36), but is based on only 19 pairs, so its sampling variance is large. Also, the observed

TABLE 3  
SUMMARY OF MEAN CORRELATION ON IQ TESTS:  
COMPARISON OF OBSERVED DATA WITH EXPECTED CORRELATIONS FOR 9 KINSHIPS

Kinship	Observed (No.)	Expected*	Correlation
MZ together	.855 (385)	.855	$= [h^2 + 2\beta^2(1 + r_{BB})b^2 + 2whb + c_{mz}e^2]$
MZ apart	.679 (19)	.360	$= h^2(1 - 2whb)^{-1}$
DZ together	.562 (206)	.525	$= [\frac{1}{2}h^2(1 + r_{AA}) + 2\beta^2(1 + r_{BB})b^2 + 2whb + c_{dz}e^2]$
Full sibs together	.520 (1951)	.525	$= [\frac{1}{2}h^2(1 + r_{AA}) + 2\beta^2(1 + r_{BB})b^2 + 2whb + c_s e^2]$
Unrelated sibs together	.289 (198)	.259	$= [2\beta^2(1 + r_{BB})b^2 + c_s e^2] (1 - 2whb)^{-1}$
adopted-adopted	.259 (94)	.295	$= [2\beta^2(1 + r_{BB})b^2 + \beta(w + r_{AB})hb + c_s e^2] (1 - 2whb)^{-1}$
Natural parent-child	.484 (1250)	.488	$= (1 + m) [\frac{1}{2}(h^2 + whb) + \beta(b^2 + whb)]$
Foster parent-child	.228 (1181)	.221	$= (1 + m)\beta(b^2 + whb) (1 - 2whb)^{-1}$
Spouses	.491 (887)	.490	$= m$

NOTE.—American data as compiled by Rao and Morton (1978), and summarized by Goldberger (1977).  
\* At point of best-fit  $\chi^2_3 = 4.35$  (.10 <  $P$  < .25) with most parsimonious acceptable model (6 parameters:  $m, \beta, h, b, c_s, c_{mz}$  bounded at unity).

value may be falsely high since several cases involved late, partial, or intrafamilial placement [17].

We conclude that all the components of phenotypic variance ( $h^2$ ,  $b^2$ ,  $2whb$ , and  $e^2$ ) make significant and substantial contributions to the resemblance between relatives in IQ test scores. Extreme hereditarian or environmentalist hypotheses appear unreasonable on the basis of available American data. The model presented here is both logically consistent and overdetermined, but serious question about the comparability of data collected by different investigators using different IQ tests at different times and locales must remain until further data are obtained. Available parameter estimates ( $59\% \leq 1-h^2 \leq 77\%$ ) suggest that social and environmental manipulations could greatly influence mean phenotypic values, even without introducing social or educational programs involving currently novel or rare experiences.

#### *Burks' Culture Index*

The development and validation of environmental indices is a valuable goal, and ideally we would like to have distinct indices of transmissible environmental effects ( $B$ ), and of effects specific to particular children ( $E$ ). Alternatively, it would be valuable to have a single index determined in part by the child's  $E$ , and in part by either the child's  $B$  or the two parents'  $B$ s, perhaps with some measurement error. Due to genic-cultural correlation, such indices would not be uncorrelated with familial genic values, but they would not be directly determined by either genic or phenotypic values. Because it is impossible to know a priori what the properties of a particular index are, we omitted all data about environmental indices in estimating the parameters of the model. Later when we examined Burks' culture index data, problems arose in the course of model fitting which demonstrate clearly that the culture index is little more than an imperfect measure of midparent IQ and certainly not an index of home environment, as implied in the model.

Rao and Morton [5, 6] have advocated the extensive use of environmental indices in evaluating multifactorial models similar to those described here. In order to reduce the indeterminacy of their model for IQ, they [5] have used observations reported by Burks as measures of the home environment [24]. Burks reported two types of indices: (1) an index of home environment based on regression of variables on child's IQ; and (2) a culture index, consisting of the total score on five 5-point items describing the parents' speech, education, interests, home library, and artistic taste. Morton and Rao use only the culture index in their analyses, presumably because regression on child's IQ would necessarily confound correlates of both cultural and genetic effects. Elsewhere they use parental socioeconomic status as a measure of home environment [21]. Here we restrict ourselves to consideration of Burks' culture index to illustrate the dangers involved in assuming arbitrarily that any more-or-less plausible index is a measure of relevant home environment.

Burks reported three correlations involving her culture index: (1) the IQ of a child reared in an intact home with the child's culture index ( $r_1 = .44, N = 101$ ); (2) the IQ of an adopted child with the child's culture index ( $r_2 = .25, N = 186$ ); and (3) the IQ of one parent with the child's index ( $r_3 = .69, N = 205$ ). We initially attempted to fit these observations to models assuming that the culture index ( $I_C$ ) was determined by

non-genetic factors only. Specifically, we considered the possibilities that  $I_c$  was directly determined in part by the child's  $B$  or by the parents'  $B$ , plus some uncorrelated measurement error. Difficulties arose in these attempts because either the observed correlations were underpredicted, or the magnitude of the paths exceeded their possible bounds. Because the assumption that the culture index was determined by non-genetic factors only did not fit the observations, we examined the alternative model depicted in figure 6.

In figure 6, the culture index ( $I_c$ ) is determined by the phenotypes of the parents (paths denoted by  $j$ ), by the child's specific environment (path  $k$ ), and by uncorrelated residual factors such as random measurement error (path  $l$ ). Thus the expected values for the correlation between the index  $I_c$  and the child's  $P$  ( $r_1$ ), between the index and an adoptee's  $P$  ( $r_2$ ), and between the index and a parent's  $P$  ( $r_3$ ) are, respectively,

$$\begin{aligned} r_1 &= j(\Gamma + 2\beta\Phi)(1 + m) + ke \quad , \\ r_2 &= j(2\beta\Phi)(1 + m) + ke \quad , \text{ and} \\ r_3 &= j(1 + m) \quad . \end{aligned}$$

The expression for full determination of  $I_c$  is given by

$$1 = l^2 + 2j^2(1 + m) + k^2.$$

Thus, fixing the parameters for the determination of IQ at the point of best fit derived from the family data previously described (see table 3), these four equations are functions of three additional unknown parameters, specifically  $j$ ,  $k$ , and  $l$ . Following this procedure, the model fit the observed data well ( $\chi^2_1 = .278$ ). The maximum likelihood estimates at the point of best fit were  $j = .461$ ,  $k = .039$ , and  $l = .603$ .

The hypothesis that the contribution of child's environment is negligible ( $k = 0$ ) is acceptable and the parsimonious model fits very well ( $\chi^2_2 = .44$ ). The expected correlations for  $r_1$ ,  $r_2$ , and  $r_3$  are .45, .21, and .69 respectively. Thus, Burks' culture index is essentially determined by the parents' IQs (specifically  $2j^2(1 + m) = .64$ ) and random variation ( $l^2 = .36$ ), so it is really an imperfect index of midparent IQ and not

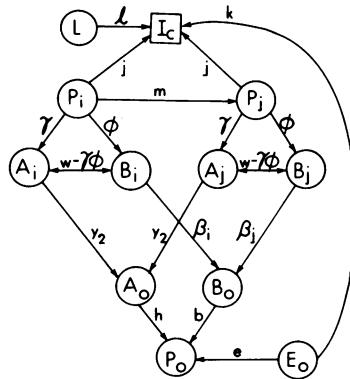

FIG. 6—Path diagram depicting the sources of determination of Burks' Culture Index ( $I_c$ ).

an index on those non-genetic factors which influence the development of IQ in children. If  $I_c$  were assumed to be a measure of home environment, the resulting estimates would be spurious and would tend to inflate heritability.

This result illustrates the difficulties involved in deriving indices of non-genetic influences and demonstrates a prudent procedure for analyzing family and index data. Rao and Morton [5, 6] suggest that data from environmental indices be used in initial estimates of the causes of phenotypic resemblance, but we conclude that data about phenotypic resemblance and about environmental indices should be evaluated separately so that tests of properties of the index and of the goodness-of-fit of the phenotypic model are not confounded. This conservative procedure requires more information but appears to be more robust.

#### DISCUSSION

##### *Implications for Estimation Procedures*

The general linear model described here provides the framework needed to consider the conditions required to distinguish genetic and cultural causes of familial resemblance. The model describes the causes of familial resemblance in terms of five to 11 free parameters. These include  $h$ ,  $b$ ,  $m$ ,  $\beta$  (or  $\beta_M$  and  $\beta_F$ ),  $c$  (or  $c_s$ ,  $d_{dz}$ ,  $d_{mz}$ ),  $p$ , and optionally  $w$  and  $i$ . Of these,  $p$  and  $i$  are paths to the indices of phenotype and graded environment; techniques for the estimation of these coefficients from reliability studies have been considered in detail elsewhere [25]. We recommend that these parameters be estimated independently of the family study, so they will not be considered in detail here. The correlation between the genic and cultural values of an individual,  $w$ , may be partly determined by unspecified causes or may be fully secondary to assortative mating. In the latter case,  $w$  may be derived from the parameters  $h$ ,  $b$ , and  $\beta$  (see equation 19). The effects of other parameters listed in table 2 ( $e$ ,  $f$ ,  $s$ ) may be derived from functions of  $h$ ,  $b$ , and  $m$ . Still at least five parameters of the model are independent, so we must ask what the critical conditions are for obtaining unique estimates of the parameters of such a multivariate model.

Degrees of freedom to estimate parameters uniquely are increased only by expressions in which the parameters are functionally independent. Accordingly, in order to estimate  $n$  parameters with  $k$  degrees of freedom to test the fit of the model,  $n + k$  independent classes of relatives must be observed. In addition, at least one of the following conditions must be satisfied: (1)  $\beta$  must differ from 1/2 in intact families; (2) observations are available about children who are not reared in intact nuclear families (e.g., separation data about adoptees or children in broken or extended families); or (3) observations based on unbiased indices of transmissible cultural factors ( $I_B$ ) are available. These conditions will each be considered now.

In intact families when  $\beta = 1/2$ , all expressions reduce to functions of  $t^2$  as shown in equations (26.1, 32.1, and 33.1). That is, an infinite set of values for  $h$ ,  $b$ , and  $w$  can be found which satisfy the expression  $t^2 = h^2 + b^2 + 2whb$ . Accordingly, unless  $\beta$  differs significantly from 1/2, estimates of  $h$  and  $b$ , and their derivatives are not possible from observations on only the phenotypes of individuals reared in intact homes.

In contrast, if  $\beta \neq 1/2$  and given an adequate number of observed classes of relatives



reared in intact homes, it is mathematically possible to obtain unique estimates of both  $h$  and  $b$  (and other parameters) because the parameters are functionally independent. However, in the absence of separation data, the independence of  $h$  and  $b$  is weak. The sampling variances of the parameter estimates are so large that impractical sample sizes would be required even assuming additivity. In the application to IQ presented here, the confidence intervals for the parameters are not small, even with separation data included. Accordingly, the unitary model previously described [1] involves little loss of information, if observations are restricted to phenotypes in intact families. In other words, observations on multiple classes of relatives (including MZ and DZ twins) from intact homes are not an adequate basis for precisely distinguishing genetic and cultural inheritance in samples of practical size. Accordingly, data about separation experiences are nearly essential for a precise evaluation of cultural transmission. Analysis of data on separation experiments will be discussed in detail elsewhere [17].

Indices of home environment offer the promise of increasing the precision of estimates of cultural inheritance and reducing the number of classes of relatives needed to specify the values of the parameters. However, as discussed in relation to our analysis of Burks' culture index, the use of such indices has serious pitfalls unless sufficient information is available to test the fit of that model without assuming the index is an unbiased estimate of non-genetic factors. Nevertheless, evaluating indices is probably the most fruitful aspect of the analysis of multifactorial traits in terms of defining hypotheses which are potentially testable and socially or therapeutically beneficial, and so merits further study as noted elsewhere [26].

#### *Interpretation in the Presence of Genic-Cultural Correlation*

A further comment on the interpretation of  $h$  and  $b$  in the presence of assortative mating or other causes of genic-cultural correlation is important. It has been claimed that  $h$  cannot be determined in the presence of gene-environment correlation [27, 28, 29] or in the absence of data on separation experiments [4]. Both claims are true if  $\beta = 1/2$ , and both are false if  $\beta \neq 1/2$  (within the statistical limitations noted). However, interpretation of  $h^2$  and  $b^2$  still appears ambiguous in the presence of genic-cultural correlation or assortative mating. Specifically, the reversed path coefficients ( $P$  on  $A$ , and  $P$  on  $B$ ) do not equal  $h$  and  $b$  as previously noted, and  $h^2$  and  $b^2$  are each complex functions of (1) the genic variance under random mating ( $V_{Ao}$ ), (2) the cultural variance under random mating ( $V_{Bo}$ ), (3) the genic-cultural correlation ( $w$ ), and (4) the correlation between mates ( $m$ ), as shown in equations (4, 5, 15, and 16):

$$h^2 = V_{Ao}/[1 - m(h + wb)^2] \text{ and } b^2 = V_{Bo} (1 - \beta_M^2 - \beta_F^2)/(1 - [\beta_M^2 + \beta_F^2 + 2\beta_M\beta_F m(b + wh)^2]).$$

Such complex relationships may account for the confusion and misunderstanding about whether genetic and cultural heritability are estimable and meaningful concepts in the presence of assortative mating or other causes of genic-cultural correlation. Nevertheless, this does not increase the number of parameters, so whenever there is sufficient information to estimate  $h$  and  $b$ , there is also sufficient information to estimate the parameters expected under random mating and in the absence of genic-cultural correlation (i.e.,  $V_{Ao}$  and  $V_{Bo}$ ).

*Alternative Models of Assortative Mating*

One comment about the correlation between the phenotypes of mates ( $m$ ) may be helpful. Direct phenotypic preference is represented here as a single-headed arrow or path coefficient, rather than as a double-headed arrow or ambiguous correlation. This treatment is consistent with Fisher's formulation of direct phenotypic assortment [12]. This should not be misinterpreted as implying "one-sided selection" in which only one individual determines the choice of mating pairs, as Wilson [30] does by confusing selective mating with pure assortative mating [31]. The correlation between mates remains the same whether one or both members of the pair determine mate selection, and the reversed path coefficients are equal for direct phenotypic assortment. Thus, the direction of the path implies only a particular frame of reference about the pedigree.

It should be emphasized that assortative mating may be due to a primary correlation between the phenotypes of mates, as described in detail earlier, or secondary to primary correlations between the immediate causes of the phenotype (i.e.,  $A$ ,  $B$ , and  $E$ ). We have emphasized primary assortative mating because in our opinion, such assortment is relatively more important for most developmental phenotypes such as height, intelligence, and personality traits. In addition, the effects of a variety of forms of secondary phenotypic assortment may be described by simple modifications of our treatment of primary phenotypic assortment, as we will now show.

The consequence of a primary path coefficient between the genic values ( $A$ ) of mates has been described by Fisher [12] as his third model, though the derivation is stated in different terms. Analogous results may be obtained to describe the effects of a primary correlation between the cultural values ( $B$ ) of mates. It is not obvious how such primary correlations might arise in pure form, except as one consequence of primary phenotypic assortment for another genetically or culturally correlated phenotype. However, a primary correlation between the non-genetic values ( $B$  and  $E$ ) of mates is perhaps not only plausible but also frequent, since this could arise due to the well-known tendency of individuals to marry neighbors, schoolmates, and individuals of approximately the same age. Furthermore, such effects of social stratification influence the resemblance between cognate relatives only to the extent that the primary correlations involve environmental factors that are transmissible between generations ( $B$ ). In other words, a primary correlation between the non-transmissible environments of mates ( $r_{EE}^*$ ) influences the correlation between the phenotypes of mates ( $\Delta r_{pp} = r_{EE}^*e^2$ ) but not the correlation between vertical or collateral relatives. Therefore, the effects of social stratification reduces to the model of a primary path between the transmissible cultural values of ( $r_{BB}^*$ ). Additional sources of marital resemblance ( $r_{AB}^*$ ,  $r_{BE}^*$ , and  $r_{AE}^*$ ) and simultaneous combinations of primary and secondary assortative mating are considered in detail elsewhere [26, 32].

The three causes of secondary homogamy may be subsumed into a general model of secondary phenotypic assortment in which there are three primary correlations between the immediate causes of the phenotypes of mates. In this general case,  $r_{AA}^*$ ,  $r_{BB}^*$ , and  $r_{EE}^*$  are functionally independent primary paths between the genic values, cultural values, and other environmental values of mates, respectively. Then the correlation between the phenotypes of mates ( $r_{pp}$ ) under secondary phenotypic assortment is

$$r_{pp} = r_{AA} * h^2 + r_{BB} * b^2 + r_{EE} * e^2 . \tag{34}$$

The path diagram depicting the causes of resemblance between relatives under secondary phenotypic assortment is shown in figure 7. Reversed paths are not involved, as they are in primary phenotypic assortment. The correlations between the immediate causes of the phenotype are represented as single-headed paths so that more than one of these correlations may occur in compound paths. This treatment is not based on arbitrary assumptions, rather it is justified by fundamental biological and statistical considerations. We assume that genetic and cultural factors are transmitted directly between successive generations only (i.e., genes and cultural influences do not skip generations in exerting their influence). In other words, denoting the value of additive transmissible factors in successive generations as the series  $n, n + 1, n + 2, \dots$ , the partial correlation between the value of transmissible factors in generations  $n$  and  $n + 2$ , holding the additive influence of the factor in the intermediate generation constant, is zero; namely,  $\rho_{(n) (n + 2) \cdot (n + 1)} = \rho_{13.2} = 0$ . By definition, then

$$\rho_{13.2} = \frac{\rho_{13} - \rho_{12}\rho_{32}}{(1 - \rho_{12}^2)^{\frac{1}{2}} (1 - \rho_{32}^2)^{\frac{1}{2}}} = 0 ,$$

so  $\rho_{13} = \rho_{12}\rho_{32}$ .

Similarly, denoting an individual's genic or cultural value as 2, and that of one of his parents and of his mate as 1 and 3, respectively,  $\rho_{13} = \rho_{12}\rho_{32}$ , because the partial correlation between the parent's and mate's genic or cultural values (when the linear influence of the individual's value is held constant) is zero. In order for this result to be implied by the path diagram, the correlations  $r_{AA}^*$  and  $r_{BB}^*$  of mates must be represented as single-headed paths because, according to convention, no path may be traced through two adjacent arrowheads. This is analogous to the earlier representation of the primary correlation between mates with a single-headed path (which is justified

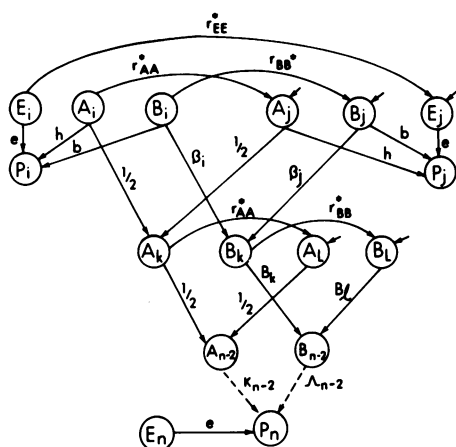

FIG. 7.—Path diagram depicting the causes of phenotypic resemblance under secondary phenotypic assortment with primary correlations between the genic values of mates ( $r_{AA}^*$ ), between the cultural values ( $r_{BB}^*$ ), and between the other environmental causes of the phenotype ( $r_{EE}^*$ ).

by the definition of primary phenotypic preference, since this implies that the partial correlation between two different mates of one individual is zero when the influence of the common individual is eliminated).

The general formulae for the resemblance between relatives under secondary phenotypic assortment are simple modifications of equations (26) and (33) for primary phenotypic assortment. Thus the correlation between vertical relatives is

$$\begin{aligned}\rho_{Vn} &= [\frac{1}{2}(1 + r_{AA}^*)hK_n \text{ and } (\beta_i + r_{BB}^*\beta_j)b\Lambda_n] , \\ &= (\frac{1}{2})^n(1 + r_{AA}^*)^nh^2 + (\beta_{in} + r_{BB}^*\beta_{jn})^nb^2 ,\end{aligned}\quad (35)$$

and the correlation between the  $i$ th descendant of one sib and the  $i$ th' descendant of the other sib is

$$\begin{aligned}\rho_{cii'} &= [\frac{1}{2}(1 + r_{AA}^*)K_j K_{j'} + (\beta_M^2 + \beta_F^2 + 2\beta_M\beta_F r_{BB}^*)\Lambda_j\Lambda_{j'}] , \\ &= [(\frac{1}{2})^n(1 + r_{AA}^*)^nh^2 + (\beta_M^2 + \beta_F^2 + 2\beta_M\beta_F r_{BB}^*) (\beta_{in} + r_{BB}^*\beta_{jn})^{n-1} b^2] \quad (36)\end{aligned}$$

where  $n$ , the degree of genetic relationship, is  $i + i' + 1 = j + j' - 1$ .

$$\begin{aligned}K_1 &= h, K_n = \frac{1}{2}(1 + r_{AA}^*)K_{n-1} = [\frac{1}{2}(1 + r_{AA}^*)]^{n-1} h , \text{ and} \\ \Lambda_1 &= b, \Lambda_n = (\beta_k + r_{BB}^*\beta_l)\Lambda_{n-1} = (\beta_k + r_{BB}^*\beta_l)^{n-1} b ,\end{aligned}$$

and in contrast to primary homogamy,  $m = r_{AB} = w = 0$ . Subscripts on  $\beta$  may be ignored or, where needed, be specified in each generation depending on the sex of the parent. In equations (34–36) it may be noted that  $r_{EE}^*$  influences the phenotypic correlation between mates but not the correlation between vertical or collateral relatives.

An alternate formulation of secondary assortative mating due to social stratification has been presented by Rao et al. [6]. Their treatment of nuclear families is exact, but their extension to more remote relatives involves the apparently restrictive assumption that all the correlations between the genotypes and childhood environments of any two members of a pedigree are proportional to the correlation between their genic values only. Such an assumption would be dubious in our formulation (but not necessarily in their model), because it would require the unlikely approximations that

$$(\frac{1}{2})^n(1 + r_{AA}^*)^n \cong \frac{\beta^n(1 + r_{BB}^*)^n}{r_{BB}^*} \cong \frac{2\beta^{n+1}(1 + r_{BB}^*)^n}{r_{BB}^*}$$

(i.e., genic correlation between individuals equals the ratio of the cultural correlation between those individuals to cultural correlation of mates for vertical and collateral relatives, respectively) or, in the terms of Rao et al. [6],  $\phi = \mu^*/\mu$ .

The applicability of any particular model to any particular trait is always an empirical question, so it is most unfortunate that the data needed to distinguish among the various alternative formulations are not available. Thus the only datum about assortative mating that is usually available is the correlation between mates in intact families, but the different causes of homogamy cannot be distinguished without other observations (such as the resemblance of an individual and various relatives' mates or multiple mates of one individual). The value of obtaining additional data should be clear now that testable and distinct alternative models have been explicitly described.

*Alternative Models of Cultural Inheritance*

Our perspective of cultural transmission allows the specification of the variance composition of the population at equilibrium (either under random mating or under assortative mating) or after any number of generations of assortative mating. Given this multigenerational perspective, we have distinguished between non-genetic factors which are transmitted from parent to offspring, and those which are specific to individuals in each generation. In addition, it is important to understand the implications and significance of our treatment of the relationship between parents' and child's phenotypes in the presence of cultural transmission. The phenotypes of parents and children are considered to be determined by genetic factors ( $A$ ), transmissible sociocultural factors ( $B$ ), and environmental factors specific to each individual ( $E$ ). Parents and their offspring resemble one another due to their having both genetic and cultural factors in common. Specifically, the  $A$ s and  $B$ s of parents and children are correlated, and the  $E$ s are independent. In contrast, some investigators have chosen to model cultural transmission in terms of parents' phenotypes having a direct influence on their children's phenotype; that is, they have specified a path from parent's phenotype to child's phenotype [44, 22], or from parent's phenotype to child's environment [6]. Although such paths superficially appear plausible when only parents and children are considered, we have eschewed such assumptions for reasons which are obvious at an evolutionary level. Most obviously, it seems unlikely that parents with the same phenotype, but different genetic and cultural values, will have the same cultural influence on their children of rearing. In addition, if there is a direct path between the phenotypes of parent-offspring pairs, this would imply not only that cultural factors are transmitted, but also (1) that genetic values of (foster) parents influence the phenotypes of the children they rear, and (2) if there is a path from parent's phenotype to child's environment, the non-transmissible environments of parent-offspring pairs are correlated. Such views about inheritance are reminiscent of the notions about acquired characteristics advocated by Lamarck. Compared to the models presented here, the neo-Lamarckian models would, in many situations, lead to inflation of estimates of  $h^2$  and  $e^2$  at the expense of  $b^2$ . Further consequences of alternative formulations of cultural inheritance and their robustness are considered in more detail elsewhere [26, 33]. The models presented here have practical advantages over other available models because they are not only logically consistent, biologically and sociologically sound, but also they may be extended to describe multi-generational pedigrees in a relatively simple and exact manner.

It is unfortunate and disappointing to note the dearth of data about multiple classes of relatives available in the genetics literature. Remote relatives provide little additional information if a trait is polygenic and cultural transmission does not occur, so investigators may have often failed to collect or publish such data in the mistaken belief that it is of little value. We hope that the results described here clarify the need for such multi-generational data in addition to providing a logically developed and comprehensive model for the quantitative analysis of such valuable data about complex multifactorial traits.

## ACKNOWLEDGMENTS

The authors gratefully acknowledge helpful discussion and consultation with C. C. Li, Newton Morton, D. C. Rao, Paul Van Eerdewegh, Diane Wagener, and Sewall Wright during the preparation of this paper. However, any errors which may remain are the authors' responsibility.

## REFERENCES

1. RICE J, CLONINGER CR, REICH T: Multifactorial inheritance with cultural transmission and assortative mating. I. Description and basic properties of the unitary models. *Am J Hum Genet* 30:618–643, 1978
2. WRIGHT S: Statistical methods in biology. *J Am Stat Assoc* 26:155–163, 1931
3. CAVALLI-SFORZA LL, FELDMAN MW: Models for cultural inheritance. I. Group mean and within group variation. *Theor Popul Biol* 4:42–55, 1973
4. CAVALLI-SFORZA LL, FELDMAN MW: Cultural versus biological inheritance: Phenotypic transmission from parents to children. *Am J Hum Genet* 25:618–637, 1973
5. RAO DC, MORTON NE, YEE S: Analysis of family resemblance. II. A linear model for familial correlation. *Am J Hum Genet* 26:331–359, 1974
6. RAO DC, MORTON NE, YEE S: Resolution of cultural and biological inheritance by path analysis. *Am J Hum Genet* 28:228–242, 1976
7. EAVES LJ: The effect of cultural transmission on continuous variation. *Heredity* 37:41–57, 1976
8. LI CC: Progress of the kinship correlation models, in *Genetic Epidemiology*, edited by MORTON NE, CHUNG CS, New York, Academic Press, 1978
9. MORTON NE, RAO DC: Quantitative inheritance in man, in *Yearbook of Physical Anthropology*, vol 21, Washington, D.C., American Association of Physical Anthropology, 1978, pp. 12–41
10. MORTON NE: Analysis of family resemblance. I. Introduction. *Am J Hum Genet* 26:318–330, 1974
11. LI CC: *Path analysis—a primer*. Pacific Grove, California, Boxwood Press, 1975
12. FISHER RA: The correlation between relatives on the supposition of Mendelian inheritance. *Trans R Soc Edin* 52:399–433, 1918
13. WRIGHT S: The application of path analysis to etiology, in *Genetic Epidemiology*, edited by MORTON NE, CHUNG CS, New York, Academic Press, 1978
14. CAVALLI-SFORZA LL, BODMER WF: *The Genetics of Human Populations*. San Francisco: WH Freeman, 1971
15. CATTELL RB, NESSELROADE JR: Likeness and completeness theories examined by sixteen personality factor measures on stably and unstably married couples. *J Pers Soc Psychol* 7(4):351–361, 1967
16. SLATER E, COWIE V: *The Genetics of Mental Disorders*. London, Oxford Press, 1971
17. CLONINGER CR, RICE J, REICH T: Multifactorial inheritance with cultural transmission and assortative mating. III. Family structure and the analysis of separation experiments. *Am J Hum Genet*. In press, 1979
18. RAO CR: *Linear Statistical Inference and Its Applications*, 2d ed., New York, John Wiley, 1973, p. 194
19. LI CC: *Population Genetics*. Chicago and London, University of Chicago Press, 1972
20. WRIGHT S: *Evolution and the Genetics of Populations*, vol I: Genetic and biometric foundations. Chicago and London, University of Chicago Press, 1968
21. RAO DC, MORTON NE: IQ as a paradigm in genetic epidemiology, in *Genetic Epidemiology*, edited by MORTON NE, CHUNG CS, New York, Academic Press, 1978
22. JENCKS C: *Inequality: A Reassessment of the Effect of Family and Schooling in America*. New York, Basic Books, 1972

23. GOLDBERGER AS: Models and methods in the IQ debate: Part I. Mimeograph Series, Social Systems Research Institute, University of Wisconsin, Madison, September, 1977
24. BURKS BS: The relative influence of nature and nurture upon mental development. *Twenty-seventh Yearbook of the National Society for the Study of Education*, Part I. Bloomington, Public School Publishing, 1928, pp. 219–316
25. CLONINGER CR, MILLER JP, WETTE R, MARTIN RL, GUZE SB: The evaluation of diagnostic concordance in follow-up study: A general model of causal analysis and a methodological critique. *J Psychiatr Res*. In press, 1978
26. CLONINGER CR, RICE J: Resolution of polygenic and cultural inheritance from reciprocal phenotype—environment interaction. Submitted for publication, 1978
27. MORAN PAP: A note of heritability and the correlation between relatives. *Ann Hum Genet* 37:217, 1973
28. HOLYROYD RG: On Moran's note on heritability. *Ann Hum Genet* 38:379, 1975
29. LAYZER D: Heritability analysis of IQ scores: Science or numerology? *Science* 183:1259–1266, 1974
30. WILSON SR: The correlation between relatives under the multifactorial model with assortative mating. *Ann Hum Genet* 37:189–204, 1973
31. LEWONTIN R, KIRK D, CROW J: Selective mating, assortative mating, and inbreeding: Definitions and implications. *Eugen Q* 15(2):141–143, 1968
32. RAO DC, MORTON NE, CLONINGER CR: Path analysis under generalized assortative mating. *Genet Res*. In press, 1979
33. RICE J, CLONINGER CR, REICH T. The analysis of behavioral traits in the presence of cultural transmission and assortative mating: Applications to IQ and SES. Submitted for publication, 1978