

SHORT REPORT

Two clinicopathological cases of a dominantly inherited, adult onset orthochromatic leucodystrophy

F Letournel, F Etcharry-Bouyx, C Verny, A Bartheleix, F Dubas

J Neurol Neurosurg Psychiatry 2003;**74**:671–673

Leucodystrophies of orthochromatic type are a heterogeneous group that occur mainly in childhood and have no known enzyme deficiency. We report here the clinicopathological features of a new family of orthochromatic leucodystrophy with three main characteristics: a probably autosomal dominant inheritance; two phenotypes based on age of onset; and very few abnormalities of white matter on MRI findings in one case.

The first patient, aged 58 years, had frontal dementia and epilepsy; the second, aged 38 years, had motor signs and dementia, but no epilepsy. The histopathological features of our two cases were leucodystrophy of orthochromatic subtype. However, the radiological features (MRI and mostly FLAIR sequences) of the first case did not suggest leucodystrophy.

Primary leucodystrophies are rare disorders characterised by involvement of white matter, caused by metabolic defects of transport or catabolism of myelin sphingolipids or specific proteins. These diseases are considered to be genetic disorders that occur mainly in childhood. However, some are of adult onset including metachromatic leucodystrophy (MLD),¹ Krabbe's disease,² or adrenoleucodystrophy (ALD).³ There is a heterogeneous group, which has no known enzyme deficiency, called non-metachromatic leucodystrophy or orthochromatic leucodystrophy.⁴ The lipid catabolism in this group is of sudanophilic type. Most cases are sporadic but a few families with a dominant inheritance have been described. They can be a pigmentary type of orthochromatic leucodystrophy,⁵ associated with cerebellar ataxia and dementia,⁶ or mimicking chronic multiple sclerosis (cerebellar ataxia, pyramidal dysfunction, disturbance of autonomic nervous system) and related to chromosome 5q31.^{7,8}

We report here the clinicopathological features of a new family of orthochromatic leucodystrophy with three main characteristics: a probably autosomal dominant inheritance, two phenotypes based on age of onset, and very few abnormalities of white matter on MRI findings in one case.

CASE REPORTS

The family

The family (fig 1A) is of north Italian origin. It came to our attention when propositus III-1, aged 57, and III-9, aged 38, were examined by two of us (FL and FD). There was no consanguinity. The grandfather (I-1) died around 45 years of age from a myocardial infarction, and his wife (I-2) from an unknown aetiology, before the age of 50.

Case III-1

This 57 year old woman (fig 1A), without personal history, had a six months history of difficulties in executive functions, mainly regarding learning new tasks. She then had three generalised convulsions with a right hemiparesia lasting for 48

hours. The first neurological examination was normal. Neuropsychological examination showed predominantly a frontal dysfunction. There were some linguistics anomalies (severe reduction of verbal fluency test), impairment on Luria's motor examination tasks,⁹ and conceptual apraxia with no constructional apraxia or agnosia. Her intellectual efficiency was poor (on the Wechsler Adult Intelligence Scale-Revised verbal,¹⁰ IQ of 72, performance IQ of 81, and total IQ of 74). Some memory difficulties and even more severe frontal dysfunction were seen in classic executive function tests (Tower of London planning test,¹¹ Stroop colour word test,¹² modified card sorting test,¹³ and trail making test¹⁴). Routine blood tests were normal. A moderate increase of proteins (1.3 g/l) in her cerebrospinal fluid (CSF), without cells, was noted. Levels of arylsulphatases A and B, very long chain fatty acids (VLCFA), hexosaminidases A and B, mannosidases, fucosidases, and galactosidases were normal. Computed tomography (CT) scan showed frontal atrophy and enlarged ventricles. Brain magnetic resonance imaging (MRI) confirmed a predominantly frontal cortical and corpus callosum atrophy. Few hyperintensities in the frontal white matter and periventricular zone were seen, even on FLAIR sequences (fig 1B). She died three years after the onset of the disease, with severe frontal dementia (MMSE impossible), grasping reflex, mutism, and parkinsonism. At the end of her life, MRI showed few hyperintensities in the white matter. Her mother (II-2) had the same symptoms (bulimia, severe reduction of verbal fluency, apathy, grasping reflex, convulsions) and frontal atrophy seen on gaseous encephalography. Her symptoms started at the same age and lasted for the same period (homochrony).

The whole brain showed a frontal atrophy. Coronal sections showed diffuse pallor of the white matter, gelatinous aspect, and a frontal predominance as the aspect as in III-9 (fig 1F). The brain stem, cerebellum, and infratentorial white matter were normal. On haematoxylin-phloxin staining, demyelination was evident (fig 1C), sparing U fibres. A cavitation was seen. Posteriorly lesions were less severe. Axons were relatively spared, and an occasional perivascular inflammation reaction was noted (fig 1C). Macrophages were sparse, containing luxol and Sudan Red positive material (fig 1D). No pigmented glial cells were seen. The grey matter, thalamus, caudate, optic tracts, cerebellar grey and white matter, brain stem nuclei, and long tracts were unremarkable.

Case III-9

This 38 year old man (fig 1A), without personal history, presented with pyramidal syndrome of the right leg which had been present for several months. The first neurological examination showed a right hemiparesia with pyramidal signs. Brain tomodensitometry (CT scan) showed marked,

Abbreviations: ALD, adrenoleucodystrophy; CSF, cerebrospinal fluid; CT, computed tomography; MLD, metachromatic leucodystrophy; MRI, magnetic resonance imaging; VLCFA, very long chain fatty acids

diffuse, and symmetric hypodensities of the white matter (fig 1E). There was no sign of atrophy. Routine blood tests were normal. CSF examination was unremarkable and arylsulphatases A and B were normal. His symptoms were progressive with a right hemiplegia and cortical blindness at the end of the evolution. Neuropsychological examination showed a spatial dysgraphia, a constructional apraxia (0 at cubes on the Wechsler Adult Intelligence Scale). Some memory difficulties were present and his intellectual efficiency was poor. There were neither comportmental abnormalities nor agnosia. These results were in favour of a diffuse neuropsychological alteration. No convulsion was noted during the illness. He died after two years. His mother (II-4) and one of his sisters (III-11) had the same clinical signs (homochrony) ascertained by neurological examination, which differed from those of their cousin (III-1).

The whole brain showed no gross abnormality. Coronal sections and microscopic examination showed the same lesions as III-1, with demyelination sparing U fibres (fig 1F). However, demyelination was more prominent in the occipital white matter and macrophagic reaction was more evident without pigments. No pigmented glial cells were seen. Ultrastructural study showed electron dense lamellar inclusions with curved or parallel arrangement giving a fingerprint pattern (fig 1G). These macrophagic inclusions were not membrane bound. The grey matter, thalamus, caudate, optic tracts, cerebellar grey and white matter, brain stem nuclei, and long tracts were unremarkable.

DISCUSSION

Orthochromatic leucodystrophy is a rare heterogeneous group of primary leucodystrophy,³ in which most cases are sporadic.

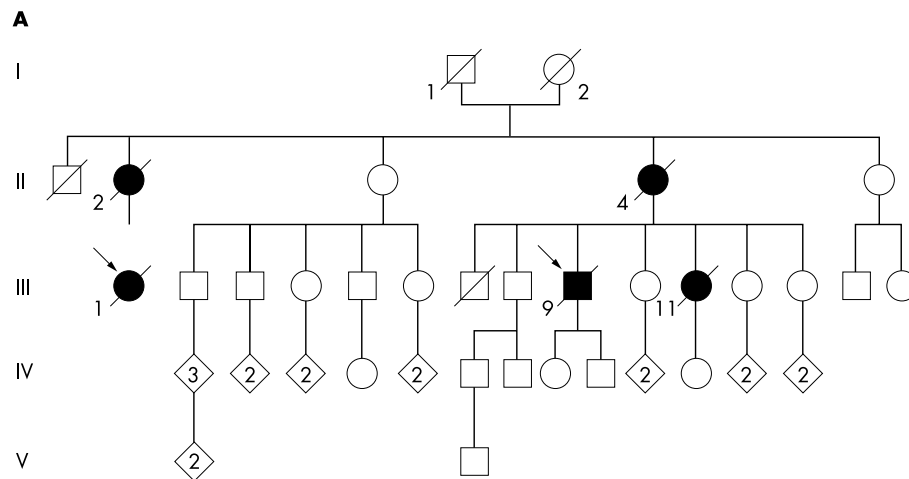
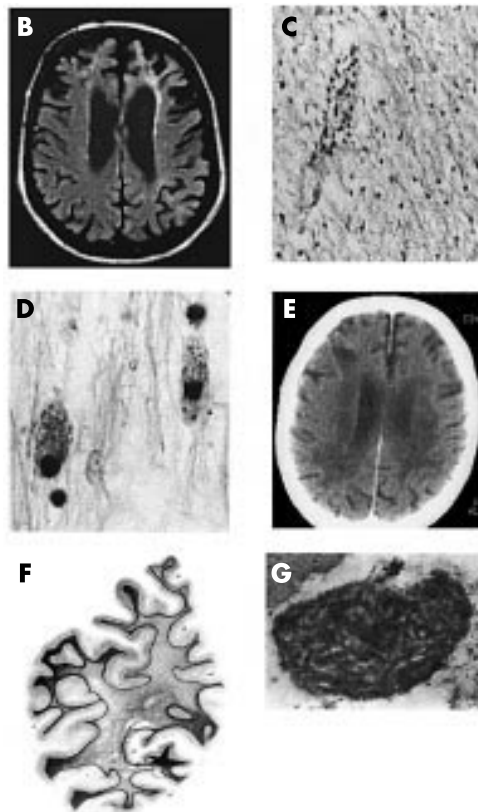

Figure 1 Imagery, histological features, and pedigree of the kindred. (A) Pedigree of the kindred with hereditary orthochromatic leucodystrophy. Affected subjects are indicated by solid symbols, deceased subjects by slashed symbols, females by circles, males by squares, and subjects of both sexes by diamonds. (B) Axial MRI (FLAIR sequence) of patient 1 showed frontal atrophy and few hyperintensities in the white matter. (C) Haematoxylin-phloxin staining of patient 1 showed demyelination, perivascular reaction, and preservation of axons. (D) Sudan Red staining of patient 1 showed lipid accumulation in macrophages. (E) CT scan of patient 2 showed hypodensities of the white matter. (F) Woelcke staining of patient 2 showed intense and diffuse demyelination sparing U fibres. (G) Fingerprint inclusion; patient 2.



The primary metabolic defect is not known, although the defect in one family has been linked to chromosome 5.⁸ Adult onset dominant families have rarely been described; they may have cerebellar signs and dementia,⁶ or cerebellar, pyramidal, and autonomic abnormalities,¹⁵ and symptoms can mimic chronic multiple sclerosis (as in our second case).^{7,16} However, for dementia, the least common aetiology is primary leucodystrophy.

The second case was misdiagnosed as chronic progressive multiple sclerosis and the first as having a ceroid lipofuscinosis. There was no history of consanguinity. Case II-2 had the same signs as III-1, but no histopathological data were available. Clinical symptoms of II-4 and III-11 were identical to III-9. Except for III-11, in whom hypodensities of the white matter (CT scan) were noted, no radiological or histopathological data are available. In this family a homochrony does exist; based on clinical features two phenotypes can be individualised: one, after 55 years of age, including frontal dementia and epilepsy; and the second in the fourth decade, including motor signs and dementia, but no epilepsy.

The histopathological features of our two cases proved to be leucodystrophy of orthochromatic subtype. Lesions were bilateral, symmetrical, sparing peripheral nerves and U fibres, with macrophages containing sudanophilic, non-metachromatic lipids. The striking macrophage reaction, more prominent in the second case, was most probably related to the short term evolution (two years). However, one interesting feature is the occipital dominance of lesions in the second case, as usually they are frontal.^{17,18} ALD and MLD were excluded in this family because of the levels of arylsulphatases A and B, and VLCFA.¹ Binswanger's disease was unlikely as no evidence of infarcts was noted. Fingerprint inclusions have been observed in various types of ceroid lipofuscinosis. However, they have been reported in pigmentary leucodystrophies,¹⁷ and are compatible with this diagnosis.

The inheritance of our family is most likely dominant since both a parent and a child of both sexes are affected over two generations. However, the phenotype does not resemble other phenotypes in the literature.^{6,7,15,19}

CT findings were compatible with a white matter disease in the second case (III-9), including diffuse, but symmetric, hypodensities. However, the radiological features of the first case were not in favour of leucodystrophy, until the postmortem examination. MRI and mostly FLAIR sequences are supposed to be a very sensitive tool to detect white matter abnormalities, even before clinical signs.^{3,20} To our knowledge this is the first case report of a primary leucodystrophy in which no evident hyperintensities are noted on MRI; however, normal neuroimaging has been reported in a case of proven adult onset Krabbe's disease.²¹ It might related to a poor macrophagic reaction or a lack of sensitivity of MRI, even if FLAIR sequences have been done. This means that absence of pathological changes of the white matter does not rule out the diagnosis of leucodystrophy.

In conclusion, we have described a new hereditary orthochromatic leucodystrophy characterised by late adult onset, probably dominant inheritance, a phenotype depending

on age of onset, a relatively short term evolution (two to three years after clinical onset) and, at least in one case, MRI findings not immediately suggestive of white matter disease.

Authors' affiliations

F Letournel, A Barthelaix, Cell Biology Laboratory, CHU, 49033 Angers, France

F Dubas, F Etcharry-Bouyx, C Verny, Department of Neurology, CHU, 49033 Angers, France

Correspondence to: Professor F Dubas, Department of Neurology, CHU, 49033 Angers, France; FrDubas@chu-angers.fr

Received 20 August 2002

Accepted 3 December 2002

REFERENCES

- Baumann N**, Carreau V, Lefevre M, *et al.* Adult forms of metachromatic leucodystrophy: clinical and biochemical approach. *Dev Neurosci* 1991;**13**:211–15.
- Kolodony EH**, Raghavan S, Krivit W. Late onset Krabbe disease (globoid cell leukodystrophy): clinical and biochemical features of 15 cases. *Dev Neurosci* 1991;**13**:232–9.
- Baumann N**, Turpin JC. Adult-onset leucodystrophy. *J Neurol* 2000;**247**:751–9.
- Turpin JC**, Gray F, Baumann N. Leucodystrophies. In: *Encyclopédie médico-chirurgicale*. Paris, 17-076-D-10.
- Constantinidis J**, Wisniewski TM. The dominant form of the pigmentary orthochromatic leucodystrophy. *Acta Neuropathol* 1991;**82**:483–7.
- Tagawa A**, Ono S, Inoue K, *et al.* A new familial adult onset leucodystrophy manifesting as cerebellar ataxia and dementia. *J Neurol Sci* 2001;**183**:47–55.
- Eldridge R**, Anayiotos CP, Schlesinger S, *et al.* Hereditary adult-onset leucodystrophy simulating chronic progressive multiple sclerosis. *N Engl J Med* 1984;**311**:948–53.
- Coffeen C**, McKenna CE, Koeppen AH, *et al.* Genetic localization of an autosomal dominant leucodystrophy mimicking chronic progressive multiple sclerosis to chromosome 5q31. *Hum Nat Genet* 2000;**9**:787–93.
- Luria AR**. *Higher cortical functions in man*. New York: Basic Books Consultants Bureau, 1966.
- Wechsler D**. *Echelle d'Intelligence de Wechsler pour Adultes (forme révisée)*. Paris: Adaptation et traduction du Centre de Psychologie Appliquée, 1989.
- Shallice T**. Specific impairments of planning. In: Broadbent DE, Weiskrantz L, eds. *The neuropsychology of cognitive functions*. London: The Royal Society, 1982:199–209.
- Stroop JR**. Studies of interferences in serial verbal reactions. *J Exp Neurol* 1935;**18**:643–62.
- Nelson HE**. A modified card sorting test sensitive to frontal lobe defect. *Cortex* 1976;**12**:313–24.
- Reitan RM**. Validity of the trail making test as an indication of brain damage. *Percept Mot Skills* 1958;**8**:271–6.
- Asahara H**, Yoshimura T, Sada S, *et al.* A Japanese family with probably autosomal dominant adult-onset leucodystrophy. *Rinsho Shinkeigaku* 1996;**36**:968–72.
- Schwankhaus JD**, Katz DA, Eldridge R, *et al.* Clinical and pathological features of an autosomal dominant, adult-onset leucodystrophy simulating chronic progressive multiple sclerosis. *Arch Neurol* 1994;**51**:757–66.
- Gray F**, Destee A, Bourre JM, *et al.* Pigmentary type of orthochromatic leucodystrophy (OLD): a new case with ultrastructural and biochemical study. *J Neuropathol Exp Neurol* 1987;**46**:585–96.
- Knopman D**, Sung JH, Davis D. progressive familial leucodystrophy of late onset. *Neurology* 1996;**46**:429–34.
- Abe K**, Ikeda M, Watase K, *et al.* A kindred of hereditary adult-onset leucodystrophy with sparing the optic radiations. *Neuroradiology* 1993;**35**:281–3.
- Bergui M**, Bradac GB, Leombruni S, *et al.* MRI and CT in an autosomal-dominant, adult-onset leucodystrophy. *Neuroradiology* 1997;**39**:423–6.
- Bajaj NP**, Waldman A, Orrell R, *et al.* Familial adult onset of Krabbe's disease resembling hereditary spastic paraplegia with normal neuroimaging. *J Neurol Neurosurg Psychiatry* 2002;**72**:635–8.