

## Identification of *algI* and *algJ* in the *Pseudomonas aeruginosa* Alginate Biosynthetic Gene Cluster Which Are Required for Alginate O Acetylation

MICHAEL J. FRANKLIN AND DENNIS E. OHMAN\*

Department of Microbiology and Immunology, University of Tennessee, and Veterans Affairs Medical Center, Memphis, Tennessee 38163

Received 19 December 1995/Accepted 30 January 1996

Mucoid strains of *Pseudomonas aeruginosa* overproduce alginate, a linear exopolysaccharide of D-mannuronate and variable amounts of L-gulonate. The mannuronate residues undergo modification by C-5 epimerization to form the L-gulonates and by the addition of acetyl groups at the O-2 and O-3 positions. Through genetic analysis, we previously identified *algF*, located upstream of *algA* in the 18-kb alginate biosynthetic operon, as a gene required for alginate acetylation. Here, we show the sequence of a 3.7-kb fragment containing the open reading frames termed *algI*, *algJ*, and *algF*. An *algI::Tn501* mutant, which was defective in *algIJFA* because of the polar nature of the transposon insertion, produced alginate when *algA* was provided in *trans*. This indicated that the *algIJF* gene products were not required for polymer biosynthesis. To examine the potential role of these genes in alginate modification, mutants were constructed by gene replacement in which each gene (*algI*, *algJ*, or *algF*) was replaced by a polar gentamicin resistance cassette. Proton nuclear magnetic resonance spectroscopy showed that polymers produced by strains deficient in *algIJF* still contained a mixture of D-mannuronate and L-gulonate, indicating that C-5 epimerization was not affected. Alginate acetylation was evaluated by a colorimetric assay and Fourier transform-infrared spectroscopy, and this analysis showed that strains deficient in *algIJF* produced nonacetylated alginate. Plasmids that supplied the downstream gene products affected by the polar mutations were introduced into each mutant. The strain defective only in *algF* expression produced an alginate that was not acetylated, confirming previous results. Strains missing only *algJ* or *algI* also produced nonacetylated alginates. Providing the respective missing gene (*algI*, *algJ*, or *algF*) in *trans* restored alginate acetylation. Mutants defective in *algI* or *algJ*, obtained by chemical and transposon mutagenesis, were also defective in their ability to acetylate alginate. Therefore, *algI* and *algJ* represent newly identified genes that, in addition to *algF*, are required for alginate acetylation.

Patients with cystic fibrosis (CF) often suffer from chronic pulmonary infections with *Pseudomonas aeruginosa*. The isolates from these patients usually display a highly mucoid colony morphology that is unusual compared with that of isolates of *P. aeruginosa* from other types of patients. This mucoid phenotype is indicative of the overproduction of a viscous exopolysaccharide called alginate (9). Alginate is a capsule-like polysaccharide that appears to confer an enhanced resistance to phagocytosis (2, 30, 33) and may also act as an adherence factor (20, 27). Combined with the high tolerance of *P. aeruginosa* to many antibiotics, alginate overproduction appears to give this opportunistic pathogen a selective advantage that leads to chronic pulmonary disease in CF patients (16). The regulation of genes for alginate production is complex and involves the deregulation of an alternative sigma factor that may be part of a stress response system in this organism (8, 21).

Alginate is a linear polymer composed of D-mannuronate and its C-5 epimer, L-gulonate, which are linked by  $\beta$ -1,4 glycosidic bonds (9, 14). Most of the genes encoding enzymes for the biosynthesis of alginate are clustered in an 18-kb operon at 34 min on the chromosome (5). However, one essential alginate gene (*algC*) is located at about 10 min on the chromosome (37). The gene products of *algA*, *algC*, and *algD* are required for the formation of the main precursor of alg-

inate, GDP-mannuronate (for a review, see reference 23). Polymerization of D-mannuronate occurs by processes not yet elucidated. At the polymer level, some D-mannuronates are converted to L-gulonates by the action of a periplasmic C-5-mannuronan epimerase encoded by *algG* (4, 12). The product of *algE* may be an outer membrane protein that is involved in polymer export (6, 28). The product of *algL* is an enzyme with alginate lyase activity (3, 29). Some of the mannuronate residues of alginate are also O-acetylated at the O-2 and/or O-3 position (7, 34). O acetylation affects the properties of alginate, including viscosity and binding of calcium ions (35), and may be important in the virulence properties associated with production of this exopolymer.

We recently reported a genetic analysis in the mucoid CF strain FRD1 of *P. aeruginosa* in which localized mutagenesis of the alginate biosynthetic cluster was used to obtain mutants that produced nonacetylated alginates (13). This permitted identification of *algF*, a gene involved in the acetylation of alginate, which was localized to a region ~1 kb upstream of *algA* by the location of a transposon (Tn501-3) insertion in the chromosome. This insertion had a polar effect on the essential gene *algA* and blocked polymer formation. Tn501-3 also blocked alginate acetylation, which could be shown by expressing *algA* in *trans* to permit polymer formation (see Fig. 1). To continue these studies, a sequence analysis of the Tn501-3 insertion site was performed, which showed that it actually lies just upstream of the sequence recently reported to contain an open reading frame (ORF) called *algF* (32). Since Tn501 insertions in the alginate operon are polar on all downstream *alg*

\* Corresponding author. Mailing address: Dept. of Microbiology & Immunology, University of Tennessee & VA Medical Ctr., 858 Madison Ave., Memphis, TN 38163. Phone: (901) 448-8094. Fax: (901) 448-8462.

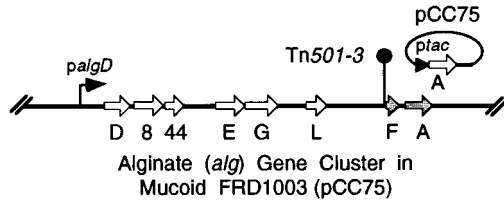

FIG. 1. Depiction of the chromosome of FRD1003, showing polar effect of Tn501-3 on *algF* and *algA*, resulting in a nonmucoid phenotype. The shaded arrow indicates a portion of the operon that is not expressed. Expression of *algA* (on pCC75) in *trans* permitted alginate production, but the polymer was not acetylated (13).

genes (5), then Tn501-3 would block *algF* expression. However, there was also the possibility that the transposon had insertionally inactivated an undefined gene that could be involved in alginate modification. To begin evaluating the role of unidentified genes upstream of *algF*, the complete sequence of the DNA downstream of *algL* through *algF* was determined.

This revealed two new open reading frames, here called *algI* and *algJ*. The results of mutant and complementation analyses of these genes are described here.

#### MATERIALS AND METHODS

**Bacterial strains, plasmids, and media.** The bacterial strains and plasmids used in this study are shown in Table 1. *Escherichia coli* and *P. aeruginosa* were routinely cultured in L broth (10 g of tryptone, 5 g of yeast extract, and 5 g of NaCl per liter). *E. coli* used for  $\lambda$  phage propagation was grown in TM broth (10 g of tryptone, 5 g of NaCl, and 2 g of maltose per liter). A 1:1 mixture of Pseudomonas isolation agar (Difco) and L agar (PIALA) was used to select *P. aeruginosa* following matings with *E. coli*. Antibiotics, when used, were present at the following concentrations (per milliliter): ampicillin (Ap), 100  $\mu$ g; carbenicillin (Cb), 300  $\mu$ g; HgCl<sub>2</sub> (Hg), 18  $\mu$ g; gentamicin (Gm), 15  $\mu$ g for *E. coli* and 250  $\mu$ g for *P. aeruginosa*; and tetracycline (Tc), 15  $\mu$ g for *E. coli* and 100  $\mu$ g for *P. aeruginosa*.

**DNA manipulations.** General DNA manipulations, including blunting the ends of restriction fragments with mung bean nuclease or Klenow fragment, were performed as described before (19). Restriction endonucleases were purchased from Boehringer Mannheim. Triparental matings were used to mobilize plasmids from *E. coli* to *P. aeruginosa* with the conjugative helper plasmid pRK2013 (10). The DNA sequences shown were determined on DNA fragments in M13mp18 and M13mp19 with the Taq DyeDeoxy Terminator Cycle Sequencing system and automated sequencer (model 373A) from Applied Biosystems. Oligonucleotide

TABLE 1. Bacterial strains and plasmids

Strain or plasmid	Genotype or phenotype <sup>a</sup>	Source or reference
<i>E. coli</i>		
HB101	<i>proA2 leuB6 thi-1 lacY1 hsdR hsdM recA13 supE44 rpsL20</i>	This laboratory
UCB1	<i>thi HfrH-797</i>	24
<i>P. aeruginosa</i> <sup>b</sup>		
FRD1	CF isolate, Alg <sup>+</sup>	26
FRD9	<i>argF</i> Alg <sup>+</sup>	This laboratory
FRD1003	<i>algJ::Tn501-3</i> Hg <sup>r</sup> Alg <sup>-</sup>	13
FRD1114	<i>algI::Tn501-14</i> Hg <sup>r</sup> Alg <sup>-</sup>	29
FRD1153	<i>algJ3</i> Alg <sup>+</sup>	13
FRD1154	<i>algJ5Δ::Gm<sup>r</sup></i> Alg <sup>-</sup>	This study
FRD1155	<i>algI6Δ::Gm<sup>r</sup></i> Alg <sup>-</sup>	This study
FRD1156	<i>algF1Δ::Gm<sup>r</sup></i> Alg <sup>-</sup>	This study
Plasmids		
pEMR2	pBR322 <i>cos oriT</i> Tn5 Ap <sup>r</sup> Km <sup>r</sup>	11
pALTER-1	Tc <sup>r</sup> Ap <sup>s</sup>	Promega
pACYC184	Tc <sup>r</sup>	New England Biolabs
pRK2013	ColE1-Tra(RK2) <sup>+</sup> Km <sup>r</sup>	10
pKK233-2	<i>ptrc</i> ColE1 replicon Ap <sup>r</sup>	Pharmacia
pMF36	pKK233-2 with <i>oriV<sub>pa</sub> oriT</i>	13
pMF54	pKK233-2 with <i>oriV<sub>pa</sub> oriT lacI<sup>q</sup></i>	12
pGMΩ1	pBR322 with a 1.5-kb <i>SmaI</i> Gm <sup>r</sup> cassette	31
pALG2	pEMR2 with 35-kb <i>P. aeruginosa</i> DNA containing <i>argF</i> and the <i>algD</i> - <i>algA</i> operon	4
pCC75	pMMB22 (IncQ) with <i>ptac</i> control of <i>algA</i> on a 2.0-kb fragment	5
pMF52	pMF36 with <i>ptrc</i> control of <i>algIJF</i> on a 3.7-kb <i>XbaI</i> - <i>BamHI</i> fragment	13
pMF120	pALTER-1 with <i>algIJFA</i> on a 5.7-kb <i>XbaI</i> - <i>Ecl136</i> I fragment	This study
pMF122	pMF120 with <i>SmaI</i> site introduced between <i>algI</i> and <i>algF</i>	This study
pMF126	pACYC184 with <i>algIJFA</i> on a 5.7-kb <i>XbaI</i> - <i>Ecl136</i> I fragment from pMF122	This study
pMF135	pMF126 with <i>algIJ-F1Δ</i> (Gm <sup>r</sup> )- <i>A</i>	This study
pMF136	pALG2 with <i>algD</i> to <i>algIJ-F1Δ</i> (Gm <sup>r</sup> )- <i>A</i>	This study
pMF116	pACYC184 with <i>algIJF</i> on a 3.7-kb <i>XbaI</i> fragment	This study
pMF118	pMF116 with <i>algI-J5Δ</i> (Gm <sup>r</sup> )- <i>F</i>	This study
pMF124	pALG2 with <i>algI-J5Δ</i> (Gm <sup>r</sup> )- <i>FA</i>	This study
pMF121	pMF116 with <i>algI6Δ</i> (Gm <sup>r</sup> )- <i>JFA</i>	This study
pMF125	pALG2 with <i>algI6Δ</i> (Gm <sup>r</sup> )- <i>JFA</i>	This study
pMF109	pMF36 with <i>ptrc</i> control of <i>algIJFA</i> on a 5.7-kb <i>XbaI</i> - <i>Ecl136</i> I fragment	This study
pMF127	pMF54 with <i>ptrc</i> control of <i>algIJFA</i> on a 5.7-kb <i>XbaI</i> - <i>Ecl136</i> I fragment from pMF120 ( <i>SmaI</i> site between <i>algI</i> and <i>algF</i> )	This study
pMF131	pMF127 with <i>ptrc</i> control of <i>algIJ-A</i> ( <i>SmaI</i> deletion)	This study
pMF115	pMF36 with <i>ptrc</i> control of <i>algJFA</i> on a 4.0-kb <i>BstXI</i> - <i>Ecl136</i> I fragment	This study
pMF107	pMF54 with <i>ptrc</i> control of <i>algFA</i> on a 3.0-kb <i>NcoI</i> - <i>Ecl136</i> I fragment	This study

<sup>a</sup> Abbreviations for phenotypes: Alg<sup>+</sup>, alginate overproduction; Alg<sup>-</sup>, nonmucoid; Tc<sup>r</sup>, tetracycline resistance; Ap<sup>r</sup>, ampicillin resistance; Cb<sup>r</sup>, carbenicillin resistance; Km<sup>r</sup>, kanamycin resistance; Hg<sup>r</sup>, HgCl<sub>2</sub> resistance; Δ(Gm<sup>r</sup>), deletion replaced with a gentamicin resistance cartridge; Tra<sup>+</sup>, transfer by conjugation.

<sup>b</sup> FRD1153 was previously described (13) as an *algF3* mutant before the sequence of the region was determined. The genotypes of FRD1003 and FRD1114 were determined in this study.

primers were synthesized on an Applied Biosystems 380B DNA synthesizer. The locations of Tn501 insertions were determined by using primers complementary to the ends of Tn501, ACTGGAAGACGGGAAGTTTC and GACGACCCCTTAGAAAGCCT. Oligonucleotide-directed mutagenesis was performed with the Altered Sites in vitro mutagenesis kit in the vector pALTER-1 (Promega). The translation initiation codon of *algF* was changed to an *NcoI* site by using the oligonucleotide GGTCATCGGGTCCATGGGTATTCCT (forming pMF99), which also changed the second codon of AlgF from AAC (Asn) to GAC (Asp). The CACGGG sequence between *algJ* and *algF* on pMF120 was changed to a *SmaI* site by using mutagenic oligonucleotide TGTTACCCCGGGCCGAGC (forming pMF123). For inducible expression of genes under *tac* or *trc* promoter control in *P. aeruginosa*, the plasmids used were pMMB22, of the broad-host-range IncQ group (1), and also pMF36 and pMF54, containing the 1.8-kb stable replication fragment (SR or *oriVpa*) for replication in *P. aeruginosa* (12, 13, 36). Specific plasmid constructions are described in Table 1.

**Gene replacement by IPEX.** McIver et al. (24) recently described the inter-plasmid exchange (IPEX) technique to move marked alleles from one plasmid to another by homologous recombination. Here, we applied this technique as an intermediate step in the construction of strains of *P. aeruginosa* with chromosomal insertions (Gm<sup>r</sup> cassette) within the *algF*, *algJ*, and *algI* genes. Convenient restriction fragments (described in the Results) containing the genes of interest were ligated into pACYC184 (Tc<sup>r</sup>), and a 1.5-kb *SmaI* Gm<sup>r</sup> cassette from pGMΩ1 (31) was used to interrupt each gene following blunt-end ligation. The pACYC184-based plasmids were transformed into the *recA*<sup>+</sup> strain *E. coli* UCBI(pALG2). pALG2 (Ap<sup>r</sup> Cb<sup>r</sup>), the target for IPEX, carried a 35-kb fragment of *P. aeruginosa* DNA encoding the entire alginate biosynthetic operon (including the genes of interest) in the allelic exchange vector pEMR2, which contains the *cos* site of λ (4). *E. coli* UCBI(pALG2) strains carrying pACYC-Gm<sup>r</sup> derivatives were grown for 18 h at 37°C on LB with ampicillin and gentamicin to allow interplasmid homologous recombination to occur. λcI857 plate lysates were prepared from 18-h cultures to package cosmids into phage particles. The lysates (filter sterilized) were used to transduce pALG2-Gm<sup>r</sup> derivatives into *E. coli* HB101 grown in TM with selection on L agar with ampicillin and gentamicin; colonies were screened for Tc<sup>r</sup>. The pALG2-Gm<sup>r</sup> derivatives were mobilized, by using conjugative helper plasmid pRK2013, to mucoid *P. aeruginosa* FRD9 (*argF*), with selection for recombinants on PIALA containing gentamicin. Strains were screened for Cb<sup>r</sup> to determine if gene replacement had occurred.

**Verification of Gm<sup>r</sup> cassette insertions by PCR.** PCR amplification of the Gm<sup>r</sup> cassette was used to ensure the position of the cassette in the genomic DNA of mutants generated by gene replacement. Oligonucleotide primers that (i) matched the 5' and 3' regions near the insertion to amplify the 1.5-kb Gm<sup>r</sup> cassette and (ii) matched the 5' region internal to the deletion and the 3' region external to the deletion, which do not amplify DNA except in the wild-type controls, were used. Amplification of *algF1Δ::Gm<sup>r</sup>* from FRD1156 was done with the 5' external primer GCCGCAACGATTGAACGAAC and the 3' external primer GCGCGGATATCTCGTTACCG, which produced a 1.6-kb fragment with mutant DNA and a 0.9-kb fragment with FRD1; with the 5' internal primer GCAACGGAGGAATACCCATG and the 3' external primer, a 0.8-kb fragment was produced only with wild-type DNA. Amplification of *algJ5Δ::Gm<sup>r</sup>* from FRD1154 was done with the 5' external primer GCAATACGCCTATATCGCG and the 3' external primer CGTTCAATCGTTCGGGCTGG, which produced a 1.6-kb fragment with mutant DNA and a 1.1-kb fragment with FRD1; with the 5' internal primer CGCGCATACGCCACTGCTC and the 3' external primer, a 1.0-kb fragment was produced only with wild-type DNA. Amplification of *algI6Δ::Gm<sup>r</sup>* from FRD1155 was done with the 5' external primer GCGATCTTCCCGCACTGAT and the 3' external primer CTGGTTGTAGAACTGGCGCA, which produced a 1.6-kb fragment with mutant DNA and a 0.8-kb fragment with FRD1; with the 5' internal primer AGTTCAACCACCGCACCCAC, a 0.7-kb fragment was produced only with wild-type DNA.

**Assays for alginate.** Alginates were collected from culture supernatants of mucoid *P. aeruginosa* strains grown for 48 h at 37°C in L broth supplemented with 1 mM IPTG (isopropylthiogalactopyranoside) and carbenicillin. Alginate was purified from culture supernatants by precipitation once with 2% cetyl pyridinium chloride and twice with isopropanol as described previously (13). The concentration of alginate in solution was determined by the carbazole method of Knutson and Jeanes (18). Briefly, a solution of purified alginate (30 μl) was mixed with 1.0 ml of borate-sulfuric acid reagent (10 mM H<sub>3</sub>BO<sub>3</sub> in concentrated H<sub>2</sub>SO<sub>4</sub>), and 30 μl of carbazole reagent (0.1% in ethanol) was added. The mixture was heated to 55°C for 30 min, and the alginate concentration was determined spectrophotometrically at 500 nm with *Macrocystis pyrifera* alginate (Sigma) as a standard.

**Assay for mannuronan C-5 epimerization of alginate.** <sup>1</sup>H nuclear magnetic resonance (<sup>1</sup>H-NMR) spectroscopy was used to evaluate alginate structure as previously described (4). Briefly, alginate samples were partially depolymerized by mild acid hydrolysis, lyophilized, and dissolved in D<sub>2</sub>O (Sigma). NMR spectra were recorded at 300 MHz in the Fourier transform mode at 90°C.

**Assays for O acetylation of alginate.** A chemical method described by Hestrin (17) was used to measure alginate acetylation. Briefly, 500 μl of an alginate solution was incubated with 500 μl of alkaline hydroxylamine (0.35 M NH<sub>2</sub>OH, 0.75 M NaOH) for 10 min at 25°C. The reaction mixture was acidified with 500 μl of 1.0 M perchloric acid, followed by the addition of 500 μl of 70 mM ferric

perchlorate in 0.5 M perchloric acid. The concentration of acetyl groups was determined spectrophotometrically at 500 nm from a standard curve, with ethyl acetate as the substrate. Alginate acetylation was also examined by Fourier transform-infrared spectroscopy (FT/IR) as described previously (13). Purified alginates (250 μl) were spotted onto IR cards (3M Co.), air dried in a laminar flow hood, and stored in desiccators. Spectra were collected with a Mattson Galaxy series 2020 spectrometer, with an IR card containing no alginate as the background.

**Nucleotide sequence accession number.** The nucleotide sequence data reported here for *algJF* have been deposited in the GenBank database under accession number U50202.

## RESULTS

**Sequence analysis of the *algF* region reveals *algJ* and *algI*.** To begin evaluating the role of any genes that may be located upstream of *algF*, we determined the nucleotide sequence of a 3.7-kb *XbaI*-*Bam*HI fragment from the alginate biosynthetic gene cluster of strain FRD1 whose expression (on pMF52) complemented the acetylation defect in FRD1153 (13). This revealed three ORFs: *algI*, *algJ*, and *algF* (Fig. 2). This overlapped the end of recently reported sequences (29) that included this *XbaI* site and showed that *algL* is immediately upstream of *algF*.

The *algF* ORF (bp 2843 to 3493 in Fig. 2) predicted a protein with a mass of 22.8 kDa, charge of 8.1, and isoelectric point of 9.4. A potential ribosome-binding site was observed 8 bp upstream of *algF*. The sequence of *algF* in strain FRD1 showed six differences from the sequence reported for *algF* in *P. aeruginosa* 8830 (32). The difference at bp 2874 would result in a threonine instead of an asparagine. All of the other differences in *algF* (at bp 3055, 3124, 3226, 3394, and 3490) were in wobble positions of each codon, and none resulted in amino acid changes between the two strains. Three other base pair differences were observed (at bp 3507, 3639, and 3641), but they were in the noncoding region between *algF* and *algA*. A recent homology search for similarity to AlgF sequences did not reveal any proteins with striking homology.

The *algJ* ORF (bp 1596 to 2771 in Fig. 2), located immediately upstream of *algF*, predicted a protein with a mass of 43.1 kDa, charge of -9.7, and isoelectric point of 5.3. A potential ribosome-binding site was observed 8 bp upstream of *algJ*. A homology search of AlgJ showed homology (30% identity and 69% similarity) to AlgX (accession number U27829) (25), expressed by a gene that is also located in the *P. aeruginosa* alginate biosynthetic operon located between *algG* and *algL* (Fig. 3A). However, AlgX does not yet have a known function. The homology search did not reveal any other proteins with striking homology to AlgJ. The sequence analysis of a clone containing the Tn501-3 insertion (shown in Fig. 1 and 2) indicated that its insertion would truncate the last 70 amino acids of AlgJ. Thus, strain FRD1003 should be described as an *algJ::Tn501-3* mutant rather than an *algF* mutant, as previously reported (13). However, because of the polar nature of Tn501-3, FRD1003 is defective in *algJFA*.

The *algI* ORF (bp 19 to 1581 in Fig. 2), located immediately upstream of *algJ*, predicted a protein with a mass of 58.7 kDa that was mostly hydrophobic, with a charge of 6.3 and an isoelectric point of 8.8. A potential ribosome-binding site was found 8 bp upstream of the *algI* ORF. A homology search of AlgI sequences showed the greatest overall similarity (21% identity and 42% similarity) to *Bacillus subtilis* DltB (or ipa-4r) protein (accession number X73124) (Fig. 3B). The DltB protein appears to be a membrane protein and may function in the transport of activated D-alanine through the membrane for the biosynthesis of D-alanyl-lipoteichoic acid (15).

**Strategy for construction of *algI*, *algJ*, and *algF* deletion mutants.** To examine the potential roles of the *algJF* genes in

<p><b>XbaI RBS</b> TCTAGAGAGGAGAGAGCGCATGGTCTTTCTTCAAAAGTGTCTCTGTTCTCTGTTCTCGCG 60 M V F S S N V F L F L F L P <b>aldI</b>&gt;</p> <p>GTCCTTCTCGCGCTGTACTACCTGAGCGGGCAACGTTACCGGAACTGCTGCTGCTGATC 120 V F L G L Y Y L S G E R Y R N L L L L I <b>Tn501-14</b></p> <p>GCCAGCTACGTGTCTACCGCTGGTGGCGGGTGGACTTCTCTCTGCTGTTCCCGGGGTC 180 A S Y V F Y A W W R V D F L L L F A G V</p> <p>ACCGTCTCAACTACTGGATGGCTGGCGATCGCGCGCGCGGGGTACGCCACAGGGCC 240 T V F N Y W I G L R I G A A G V R T R A</p> <p>GCGAACGCTGGTGACTCTCGGCGTGGTGGTGGACTCTGCGGTGCTCGGGTACTTCAAG 300 A Q R W L I L G V V V D L C V L G Y F K</p> <p>TAGCCAACTTCGGCGTGCAGCGCTCAACAGAGATCATCACCTCGTTCGGCATGCAGCGG 360 Y A N F G V D S L N E I I T S F G M Q P</p> <p>TTGCTGCTGACCCACATCTCTGCTCGGATCGCATCTCTCTTACACTTTCGAGTGCATC 420 F V L T H I L L P I G I S F Y T F E S I</p> <p>AGCTACATCATCGACTCTACCGCGCGGATACCGCGGGACCCACAACCTGATCGACTTC 480 S Y I I D V Y R G D T P A T H N L I D F</p> <p>GCGCGCTTCGTCGGGATCTTCCCGCATCTGATCGCGCGCGCGGGTTCGCGCTTCAAGGAC 540 A A F V A I F P H L I A G P V L R F K D</p> <p><b>SexAI</b> CTGTGTGACGATTCACCCAGCCACACCGTGCACAGTTCGCGGAAAGGCTGCGCC 600 L V D Q F N H R T H C T T V D K F A E G C T</p> <p>CGCTCATGCGAGGCTTGTCAAGAAGTGTTCATCGCGGACACCGTGCAGCGCGCTCGCC 660 R F M Q G F V K K V F I A D T L A A L A</p> <p>GACCACTGCTTCCCGCTGCAGAACCCGACCCAGCGCGCGCGCTGCGCGCGCGCTGGCC 720 D H C F A L Q N T G G D A W L G A L A</p> <p>TACACCGCGGACTCTACTTTCGACTTCTCCGGCTACAGCGGATGCGCATCGCGCTCGGC 780 Y T A Q L Y F D F S G Y S D M A I G L G</p> <p>CTGATGATGGGCTTCCCGCTTTCAGAGAACTCAACCGAGCCATACATCAGCCAGTGGATC 840 L M M G F R F M E N F N Q P Y I S Q S I</p> <p>ACCGAGTTCGGCGCGCTGGCACATCAGCGTGGACTGCGCGTGGCTGCGCGTACTCTAC 900 T E F W R R W H I S L S T W L R D Y L T</p> <p>ATCAGCGTGGCGCGCAACCGCGGACCGCTTCCAGACTACCGCAACCTGTCTCTGACC 960 I S L G G N R G S T F Q T Y R N L F L T</p> <p>ATGCTCTCGCGCGCTGTGGCAAGCGCGCAACTTCACTACATCATCTGGGCGCGCTGG 1020 M L L G L W H G A N F T Y I I W G A W</p> <p>CACCGCATGTGGCTGGCGATGAGCGCGCGCTCGAGTGAACCGCGCGCGCGCGTGTCTC 1080 H G M W L A I E R A L G V N A A P R V L</p> <p>AAACCGTGAAGTGGCGGTTCACCTTCCTCTGGTGGTGGTGGTGGTGGTGGTGGTGGTGG 1140 N P L K W A F T F L L V V I G W V I P R</p> <p>GCGGAGAACCTCGAGTGGCTGGCGATGTAAGGACGATGTTCAAGTTCGGCACCTGG 1200 A E N L Q V A W R M Y E A M F S F G T W</p> <p>CAGCTCTCCGAATGAACCGCGGACCGCTCACCGCGCTGCAAGTGGCAACCTGGTCTCTG 1260 Q L S E L N R A S L T G L Q V G T L V L</p> <p><b>SexAI</b> GCCTACTGCTGGTGGTGGTGGTGGTGGTGGTGGTGGTGGTGGTGGTGGTGGTGGTGGTGG 1320 A Y L V L A F F L R Q P L P Q L P Q</p> <p>AAGCGGCCAAGCGCGCGGCAACAGCGGACGAAAGTGGCGCGCGCGCGCGCGCGCGCGTGC 1380 K A P K A A A N S D E V A A D G P A S A</p> <p>CACCG 1440 Q P R A P R E A A G D P A A I A Y S P S</p> <p><b>BetXI</b> GGCGCGTGTCTACCGCGGACTGGCTCAGCGAGTGGCGCGTGGCGCGCGCGCGCGCGCG 1500 G A L V Y Q P S W L S Q L P V L A T R L</p> <p>GCGCTGCTCTGTGTGGCGCGCTGGTGGTGGTGGTGGTGGTGGTGGTGGTGGTGGTGGTGG 1560 A L L L L F A A S V L K L S A Q S Y S P</p> <p><b>RBS</b> TTCTCTACTTCCAGTTCAGCG 1620 F L Y F Q P * M T Q S I S R P L</p> <p><b>SapI</b> TGCAATACCGCTATATCGCGCGCTTGGCGCGCGCTGCTGCGCGCGCGCGCGCGCGCGCG 1680 Q Y A Y I A A F G G L L G L A G W S L</p> <p>TGAAGCGCTGGCGCGCTTCTCGCGCGCGCGCGCGCGCGCGCGCGCGCGCGCGCGCGCG 1740 K S V P G F S A A A D T P L L N G K L A</p> <p><b>EcoRI</b> CGCACGCTTGAAGCCACTACGACAAGGAAATCCCGATCAAGCGCGCGCGCGCGCGCGCG 1800 H A F E A H A C Y D K E F P I K R L G T N L</p> <p>TCTGGCGCGCACTGACTACCGCTTCCACGAAGCGCGCGCGCGCGCGCGCGCGCGCGCG 1860 W A A L D Y T L F H E G R P G V V I G K</p>	<p>AGGACCGCTGGCTGTTCACCGAAGAGTTCACCGCGCGCGCGCGCGCGCGCGCGCGCGCG 1920 D G W L F T D E E F K P A P S G Q Q L E</p> <p>AAGCAACTGGGCACTGGTACCGCGCGTGCAGCGCGGAGTGAACCGTGGCGCGCGCGCGCG 1980 D N W A L V R G V Q R E L N R R G V K L</p> <p>TGGTGTCTCGCGTGTACCG 2040 V L A V I P A K A R L Y P E H I G R E Q</p> <p>AGCG 2100 P A A L H D S L Y Q D F L A R A R A A G</p> <p>GCATCGACAGTCCGCGCTGCTCGCGCGCGCGCGCGCGCGCGCGCGCGCGCGCGCGCGCG 2160 I D S P D L L G S L R Q A A K D N G A V F</p> <p>TCCTGGCAGCAGCAACCGCTGGTGGCGCGCGCGCGCGCGCGCGCGCGCGCGCGCGCGCG 2220 L R T D T H W S P L G A E T V A Q R L G</p> <p>GCGCGGAGTCCCGGAGACCGCTGCTGGATGTCGCGCGCGCGCGCGCGCGCGCGCGCGCG 2280 A E I R E T H L L D V P A Q N F V T R V</p> <p>TGGCGGAAGCGCACCGCAAGCGCGCGCGCGCGCGCGCGCGCGCGCGCGCGCGCGCGCG 2340 G E E R T H K G D L L S F L P L D P L F</p> <p>TGACGAACTGCTGGCG 2400 D E L L P R P E Q L Q R T T E A F A</p> <p>CACTGCG 2460 L P G G Q Q S G A G D D L F G D S Q Q P</p> <p>CGCGCGTGGCGTGGTGGCG 2520 R L A L V G T S Y S A N P R W N F E G A</p> <p><b>Tn501-3</b> CGCTGAACAGCGCGTGGTGGCGCGCGCGCGCGCGCGCGCGCGCGCGCGCGCGCGCGCG 2580 L K Q A L S A D L I N Y A K E G K G P L</p> <p>TGAAACCGACTGCGAACTGCTGCGCGCGCGCGCGCGCGCGCGCGCGCGCGCGCGCGCG 2640 E P M L E L L Q D E G F R K D P P Q L L</p> <p>TGGTCTGGAGTTTCCCGCGCGCTACCTGGCGTGGCGCGCGCGCGCGCGCGCGCGCGCGCG 2700 V W E F P E R Y L P M A S D L S Q G F D A</p> <p><b>NotI</b> CGACTGGTGGCG 2760 D W V A Q L K A S G G R D E R L A A S R</p> <p><b>SmaI*</b> GCAACGATGGAACGACCG 2820 N D * M N P M T C R R H T C T R L</p> <p><b>RBS</b> AAGAAACCG 2880 M N P M T C R R H T C T R R L</p> <p>GCGCTCGCACTTCTCTCGCGTGGCGCGCGCGCGCGCGCGCGCGCGCGCGCGCGCGCGCG 2940 A C A L S L G V A A F A A Q A D E G A L</p> <p>GTAACCG 3000 Y G P Q A P K G S A F R G A N A G N S</p> <p>CGAACTCGAGTGTGGTGGCG 3060 E L D V S V G S T S L N D V A P L G S S</p> <p>CGACTCAAGTTCCTCCCG 3120 D F K F L P P G S Y T A Q V G Q Q S L P</p> <p>GGTGAAGTTCGACCG 3180 V K L D P D S Y Y T L V S Q P G G K P Q</p> <p>GCTGGTGGCG 3240 L V A E P P P F K N K Q K A L V R V Q N L</p> <p>CAGCGCGTGAAGTCAAGCG 3300 S G S K L T L K T A D G F K T D V K D V</p> <p>CG 3360 G P Q S H G D R E I N P V K V N L A L F</p> <p>CGAGCG 3420 D G S G K K V S D L K P V T L A R G E V V</p> <p>CTGCTGTACGTCAACCG 3480 C L Y V T G S G G K L A P V W V K R P V</p> <p>GAAAGCGGATGAGACCG 3540 K A D * C C G C C A C A C A A A G A</p> <p>CCG 3600 T C A C C C G G G G C T C C G T G A G C C C G T A C G A G A T A C C C G C G G C G G G A T C C</p>
---	--

FIG. 2. Sequence of a 3.7-kb *XbaI-BamHI* fragment from the alginate biosynthetic operon of strain FRD1 containing the *algIIF* ORFs and their inferred protein sequences. Indicated in the sequence are the ribosome-binding sites (RBS), pertinent restriction sites, and the insertion sites of *Tn501-3* (FRD1003) and *Tn501-14* (FRD114). *SmaI\** indicates the location of this restriction site introduced by oligonucleotide mutagenesis (FRD1156).

polymer formation or its modification (i.e., acetylation or epimerization), defined mutants of mucoid strain FRD were constructed. For this, we used an IPEX technique described by McIver et al. (24) to move marked alleles from small plasmid clones to a larger clone (pALG2) in a gene replacement vector. pALG2 (see Fig. 4A) carries a 35-kb fragment of *P. aeruginosa* DNA encoding the entire alginate biosynthetic operon (*algD* through *algA*, including the genes of interest) in the allelic

exchange vector pEMR2 (conferring Ap<sup>r</sup> and Km<sup>r</sup>). pALG2 has been used previously for efficient gene replacement of the chromosomal alginate operon by homologous recombination (4, 11, 13). Our strategy here was to develop derivatives of pALG2 with mutant deletion alleles of *algI*, *algJ*, and *algF* that could be exchanged with the chromosome. Convenient restriction fragments containing the *algIIF* genes were each ligated into pACYC184 (conferring Tc<sup>r</sup> and Cm<sup>r</sup>), and a Gm<sup>r</sup> cassette

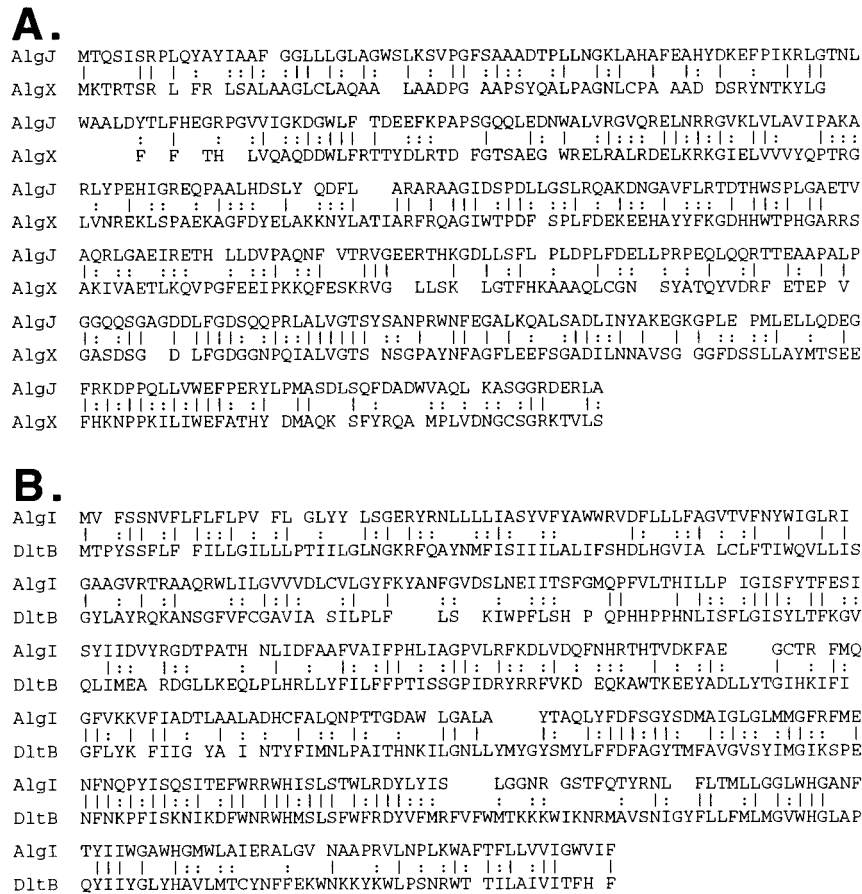

FIG. 3. (A) Sequence comparison of AlgJ and AlgX (accession number U27829) (25), which is also expressed by a gene in the *P. aeruginosa* alginate biosynthetic operon and located between *algG* and *algL*. (B) Sequence comparison of AlgI and *B. subtilis* DltB (Ipa-4r) (accession number X73124), which may function in the transport of activated D-alanine through the membrane for the biosynthesis of D-alanyl-lipoteichoic acid (15).

(31) was used to replace each gene. The pACYC-based plasmids were then transformed into *recA*<sup>+</sup> *E. coli* carrying pALG2 so that the wild-type alleles could be exchanged for the mutant alleles (*algΔ*-Gm<sup>r</sup>) on pALG2 by IPEX. This method takes advantage of the *cos* site on pALG2 for in vivo packaging into phage λ particles, followed by transduction to another *E. coli* host, with selection for plasmids that inherited the Gm<sup>r</sup> marked allele by homologous recombination (Fig. 4A and B). These pALG2 *algΔ*-Gm<sup>r</sup> plasmids were mobilized to mucoid *P. aeruginosa* FRD9 (Fig. 4C), in which they do not replicate autonomously. Gm<sup>r</sup> was used to select for homologous recombination of the plasmids with the chromosome. Single cross-overs produced merodiploid colonies (Gm<sup>r</sup> Cb<sup>t</sup>) that still contained one complete alginate biosynthetic operon, and so these colonies were mucoid. Colonies were screened for loss of the vector's marker (Cb<sup>s</sup>), which indicated a double cross-over recombinant (Fig. 4D). In that the Gm<sup>r</sup> cassette in the alginate operon produces polar effects on downstream genes (shown in gray), the colonies which had undergone gene replacement (Gm<sup>r</sup> Cb<sup>s</sup>) were nonmucoid. Physical evidence for each allele in the chromosome was obtained by PCR methods (see Materials and Methods). The construction of the mutant alleles called *algF1Δ*, *algJ5Δ*, and *algI6Δ* is described below.

**Construction of mutants with defined *algF*, *algJ*, or *algI* deletions.** Figure 5 shows the location of the alginate biosynthetic gene cluster (*algD* to *algA*) on the 35-kb fragment from *P. aeruginosa* FRD1 contained in pALG2. To begin construct-

ing an *algF* mutant derivative of pALG2, the *algF1Δ* deletion allele was constructed through the manipulation of a DNA fragment containing *algIIFA* on a 5.7-kb *XbaI-EclI* fragment (pMF120). A new *SmaI* site was introduced between *algJ* and *algF* (from CACGGG, starting at bp 2798 in Fig. 2) by oligonucleotide-directed mutagenesis. The modified 5.7-kb fragment was cloned into the *XbaI* site of pACYC184 (forming pMF126), and the 0.9-kb *SmaI* fragment containing *algF* was then replaced with a Gm<sup>r</sup> cassette to form the *algF1Δ* allele (forming pMF135). The *algF1Δ* allele (Gm<sup>r</sup>) on pMF135 was exchanged by homologous recombination for the wild-type allele on pALG2 by IPEX (see Fig. 4) to form pMF136 (Fig. 5). Following mobilization to mucoid *P. aeruginosa* FRD9, colonies with gene replacements (Gm<sup>r</sup> Cb<sup>s</sup>) containing the *algF1Δ* mutant allele were nonmucoid, and one was designated FRD1156 (Fig. 5).

Mutants with the *algJ5Δ* mutant allele were constructed through the manipulation of a DNA fragment containing *algIIF* (i.e., a 3.7-kb *XbaI-BamHI* fragment in pACYC184 called pMF116). The *algJ5Δ* deletion allele was constructed by removing a 1.0-kb *SapI-NotI* fragment, forming blunt ends with Klenow, and ligating a Gm<sup>r</sup> cassette into the site (forming plasmid pMF118). The IPEX technique was used to replace *algJ* on pALG2 with the *algJ5Δ* (Gm<sup>r</sup>) deletion allele, forming pMF124, which was then used to construct *algJ5Δ* mutants of mucoid *P. aeruginosa* FRD9 as described above (see Fig. 4). Colonies undergoing gene replacements (Gm<sup>r</sup> Cb<sup>s</sup>) that con-

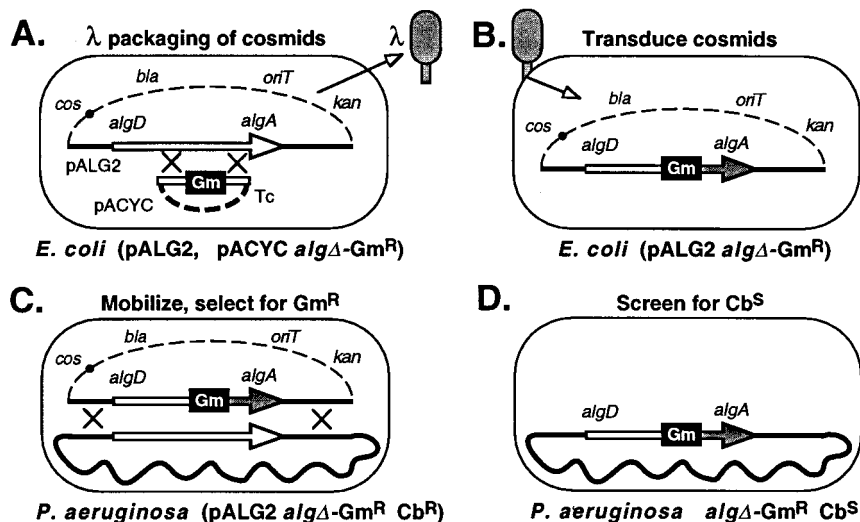

FIG. 4. Illustration of method used for gene replacement in *P. aeruginosa* of alginate genes in the biosynthetic operon with specific deletion mutations marked by a Gm<sup>r</sup> cassette. (A) Depiction of the IPEX technique (24) used to move the marked allele from one plasmid to another. A fragment of the alginate operon containing an *alg* $\Delta$ ::Gm<sup>r</sup> allele in pACYC184 replicated in the same *recA*<sup>+</sup> *E. coli* cell with compatible pALG2, a gene replacement cosmid containing the entire alginate operon (*algD*-*algA*). Rare recombinants exchanged the *alg*<sup>+</sup> allele on pALG2 for the *alg* $\Delta$ ::Gm<sup>r</sup> allele on pACYC184. Replication of  $\lambda$  phage on this host packaged the resident pALG2 cosmids. (B)  $\lambda$  lysate was used to transduce pALG2 cosmids into *E. coli*, and selection for Gm<sup>r</sup> yields pALG2 derivatives with the *alg* $\Delta$ ::Gm<sup>r</sup> allele. (C) Mobilization of pALG2 *alg* $\Delta$ ::Gm<sup>r</sup> plasmids to Alg<sup>+</sup> *P. aeruginosa* with selection for Gm<sup>r</sup> resulted in recombination with the chromosome. Long flanking regions surrounding the *alg* $\Delta$ ::Gm<sup>r</sup> marker promote frequent second recombination events, excising the relatively unstable pALG2. (D) Colonies which retain the Gm<sup>r</sup> marker were screened for Cb<sup>s</sup> and the Alg<sup>-</sup> phenotypes. The shaded arrow indicates a portion of the operon that is not expressed. The presence of the *alg* $\Delta$ ::Gm<sup>r</sup> allele in the chromosome was confirmed by PCR analysis.

tained the *algJ5* $\Delta$  mutant allele were nonmucoid, and one was designated FRD1154 (Fig. 5).

Mutants with the *algI6* $\Delta$  mutant allele were also constructed through the manipulation of *algIJF*-containing DNA (i.e., pMF116). The *algI6* $\Delta$  mutant allele was constructed by deleting a 0.7-kb *SexAI* fragment internal to *algI*, blunting the ends with mung bean nuclease, and ligating a Gm<sup>r</sup> cassette into the site (forming pMF121). The wild-type *algI* on pALG2 was replaced with the *algI6* $\Delta$  (Gm<sup>r</sup>) allele by the IPEX technique (forming pMF125). Mutants of *P. aeruginosa* FRD9 with the *algI6* $\Delta$  allele were constructed by gene replacement with pMF125. Colonies undergoing gene replacements (Gm<sup>r</sup> Cb<sup>s</sup>) that contained the *algI6* $\Delta$  mutant allele were nonmucoid, and one was designated FRD1155 (Fig. 5).

**The *algI*, *algJ*, and *algF* genes are not essential for polymer formation or C-5 epimerization.** The *algI6* $\Delta$ , *algJ5* $\Delta$ , and *algF1* $\Delta$  mutants constructed above were nonmucoid. This non-alginate-producing phenotype was due, at least in part, to the polar effect of the Gm<sup>r</sup> cassette on the downstream *algA* gene. The *algA* gene encodes a bifunctional product (22) with phosphomannose-isomerase activity (i.e., fructose 6-phosphate  $\rightarrow$  mannose 6-phosphate) and GDP-mannose pyrophosphorylase activity (i.e., mannose 1-phosphate  $\rightarrow$  GDP-mannose), which are essential early steps in the alginate biosynthetic pathway (23). To determine if the mutations in *algI*, *algJ*, or *algF* were themselves directly affecting the formation of the alginate polymer, a source of *algA* was supplied in *trans*. A broad-host-range plasmid (pCC75) with *algA* expressed under the *tac* promoter was introduced into FRD1156, FRD1154, and FRD1155. All transconjugants demonstrated the mucoid phenotype, indicating that none of the *algIJF* genes were required for the formation of extracellular polymer. All appeared to form highly mucoid colonies on L agar, suggesting that these mutations did not affect the level of alginate production.

To determine if the *algIJF* genes were involved in the structural composition of alginate, the extracellular polymers from

the *algI6* $\Delta$ , *algJ5* $\Delta$ , and *algF1* $\Delta$  mutants [FRD1155(pCC75), FRD1154(pCC75), and FRD1156(pCC75), respectively] were isolated. We recently identified the *algG* product as a C-5-mannuronan epimerase that is responsible for polymer-level epimerization of D-mannuronates to L-guluronates (4, 12). To determine if the *algIJF* genes were involved in this epimeriza-

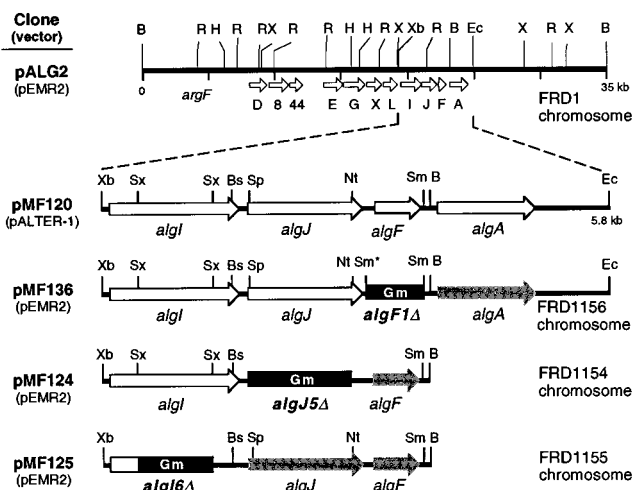

FIG. 5. Restriction maps of *P. aeruginosa* FRD1 DNA, showing the alginate biosynthetic gene cluster in pALG2 and fragments containing *algIJFA* used in this study. Plasmids designated on the lower left show the fragments cloned in pACYC184 which contained the *algF1* $\Delta$ , *algJ5* $\Delta$ , and *algI6* $\Delta$  mutant alleles which were introduced in pALG2, a gene replacement vector containing the entire alginate operon. Strain designations on the right indicate the mutants with the same changes in the *P. aeruginosa* chromosome resulting from gene replacement with the pALG2 *alg* $\Delta$ ::Gm<sup>r</sup> derivatives. The shaded arrows indicate genes not expressed. Restriction sites: H, *HindIII*; R, *EcoRI*; X, *XhoI*; Xb, *XbaI*; B, *BamHI*; Sm, *SmaI*; Sx, *SexAI*; Bs, *BstXI*; Sp, *SapI*; Nt, *NotI*; Ec, *Ecl136 I*. Sm\* indicates a *SmaI* introduced by a mutagenic oligonucleotide.

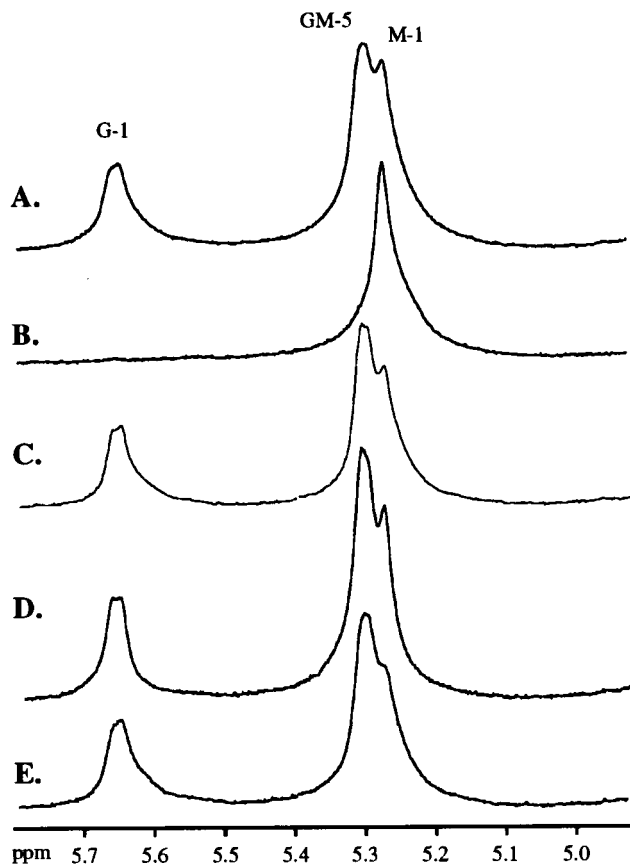

FIG. 6. NMR spectra of alginates from *P. aeruginosa*. Alginates were prepared for  $^1\text{H-NMR}$  analysis (4), and NMR spectra were recorded at 300 MHz at  $90^\circ\text{C}$ . The bacterial alginate spectrum has three characteristic peaks arising from the anomeric protons on residues of L-gulonate (G-1) and D-mannuronate (M-1) and from the protons on C-5 of guluronate residues with mannuronate neighbors (GM-5) (4). Spectra are shown for alginate from (A) wild-type strain FRD1, (B) FRD462, (C) FRD1156(pCC75), (D) FRD1154(pCC75), and (E) FRD1155(pCC75).

tion step, the polymers from these mutants were isolated and examined by  $^1\text{H-NMR}$  spectroscopy. Wild-type alginate from FRD1 (Fig. 6A) showed the characteristic peaks that have been previously associated with mannuronate (M-1) and guluronate (G-1 and GM-5) residues (4), whereas alginate from FRD462 *algG4* showed only the M-1 peak (Fig. 6B). Polymers from all of the *algI6* $\Delta$ , *algJ5* $\Delta$ , and *algF1* $\Delta$  mutants carrying pCC75 also showed the same pattern as polymer from FRD1 (Fig. 6C to E). Thus, none of the gene products of *algJIF* was essential for epimerization or AlgG activity.

**The *algF*, *algJ*, and *algI* mutants are defective in O acetylation of alginate.** The *algF1* $\Delta$ , *algJ5* $\Delta$ , and *algI6* $\Delta$  mutants (FRD1156, FRD1154, and FRD1155, respectively) produced an acetylated polymer when the complete *algJIFA* gene cluster (on pMF109 and pMF127) was expressed in *trans* under the inducible *trc* promoter (Fig. 7). In most cases, the molar ratios of acetyl groups to uronic acid residues were similar to that seen in alginate from the wild-type strain, FRD1 ( $0.50 \pm 0.1$  acetyl/uronic acid). However, the *algI* $\Delta$  mutant was complemented (with pMF109 and pMF127) to about 30 to 50% of the wild-type level, perhaps because *algI* is not sufficiently expressed in *trans* under the *trc* promoter. Polymers isolated from the mutants with only *algA* expressed in *trans* (pCC75) were found to contain little or no detectable acetyl groups when

tested in a chemical assay. In that the chromosomal *algJ5* $\Delta$  (*Gm'*) and *algI6* $\Delta$  (*Gm''*) mutations were polar on *algF*, this failure to acetylate alginate was not unexpected. To examine the individual roles of *algI*, *algJ*, and *algF* in acetylation of alginate, a series of broad-host-range plasmids that expressed various combinations of *algI*, *algJ*, and *algF* (as well as the required *algA* for polymer formation) under the control of an inducible *trc* promoter were constructed (Fig. 7): *algFA* (pMF107), *algJFA* (pMF115), *algJJA* (pMF131), and *algJIFA* (pMF109 and pMF127). Each of these plasmids was mobilized to the *algF1* $\Delta$ , *algJ5* $\Delta$ , and *algI6* $\Delta$  mutants for examination of acetylation.

The *algF1* $\Delta$  mutant (FRD1156) was deficient in only AlgF when it contained pCC75 (*algA*) or pMF131 (*algJJA*), and complementation of the acetylation defect was not observed because of the requirement for *algF* for acetylation (Fig. 7). This gene product was previously associated with alginate acetylation (12, 32), and the construction of a defined mutant here confirmed these previous results. Providing *algF* in *trans* on pMF107 (*algFA*) restored alginate acetylation. The *algJ5* $\Delta$  mutant (FRD1154) was deficient in only AlgJ when it contained pMF107 (*algFA*), and alginate acetylation was not observed. However, acetylation was restored in FRD1154(pMF115), in which *algJFA* was expressed in *trans*. This indicated that *algJ* was also required for acetylation (Fig. 7). The *algI6* $\Delta$  mutant (FRD1155) was deficient in only AlgI when it contained pMF115 (*algJFA*), and acetylation was also not observed. However, alginate was acetylated in FRD1155(pMF109) and FRD1155(pMF127) with *algJIFA* expressed in *trans*. These data indicate that *algI* and *algJ* (as well as *algF*) were required for the O acetylation of alginate (Fig. 7).

The results of the chemical assay for acetylation of alginate were verified by FT-IR spectroscopy. As shown previously (13), the acetyl ester bands in alginate can be detected as absorbance bands at  $1,730$  and  $1,250\text{ cm}^{-1}$  in wild-type FRD1 (Fig. 8A). However, no absorbance at  $1,730$  or  $1,250\text{ cm}^{-1}$  was observed in alginates purified from the *algF1* $\Delta$  mutant FRD1156(pCC75), deficient only in AlgF (Fig. 8B), in the *algJ5* $\Delta$  mutant FRD1156(pMF107), deficient only AlgJ (Fig. 8C), or in the *algI6* $\Delta$  mutant FRD1155(pMF115), deficient only in AlgI (Fig. 8D). This confirmed that all three genes (*algJIF*) appear to be required for acetylation. However, these absorption bands were restored when the missing gene was provided in *trans* in FRD1156(pMF107) (Fig. 8E), FRD1154 (pMF115) (Fig. 8F), and FRD1155(pMF109) (Fig. 8G). Consistent with the results discussed above, the *algI* $\Delta$  mutant was not fully complemented with pMF109, possibly because of insufficient expression of *algI* in *trans* relative to normal chromosomal expression.

**Complementation of transposon and point mutations affecting O acetylation.** Transposon mutations in the chromosome were also analyzed for their effects on acetylation. The transposon insertion in FRD1003 was shown by sequence analysis to be *algI::Tn501-3*. FRD1003 was mucoid with *algA* expressed in *trans* (i.e., by pCC75), but the polymer produced was not acetylated (Table 2). pMF107 (see Fig. 7), which expresses only *algFA*, did not complement its acetylation defect, but pMF115, expressing *algJFA*, was effective for complementation. The position of transposon Tn501-14 was also determined by sequence analysis and found to be in *algI* (position shown in Fig. 2). FRD1114, which has the chromosomal *algI::Tn501-14* allele, was mucoid when *algA* was provided in *trans* (by pCC75), but the polymer produced was not acetylated. pMF107 (*algFA*) and pMF115 (*algJFA*) did not complement its acetylation defect, but pMF109 (*algJIFA*) was effective (Table 2).

In addition to the transposon mutants, we recently reported a mutant (FRD1153), isolated by chemical mutagenesis, that

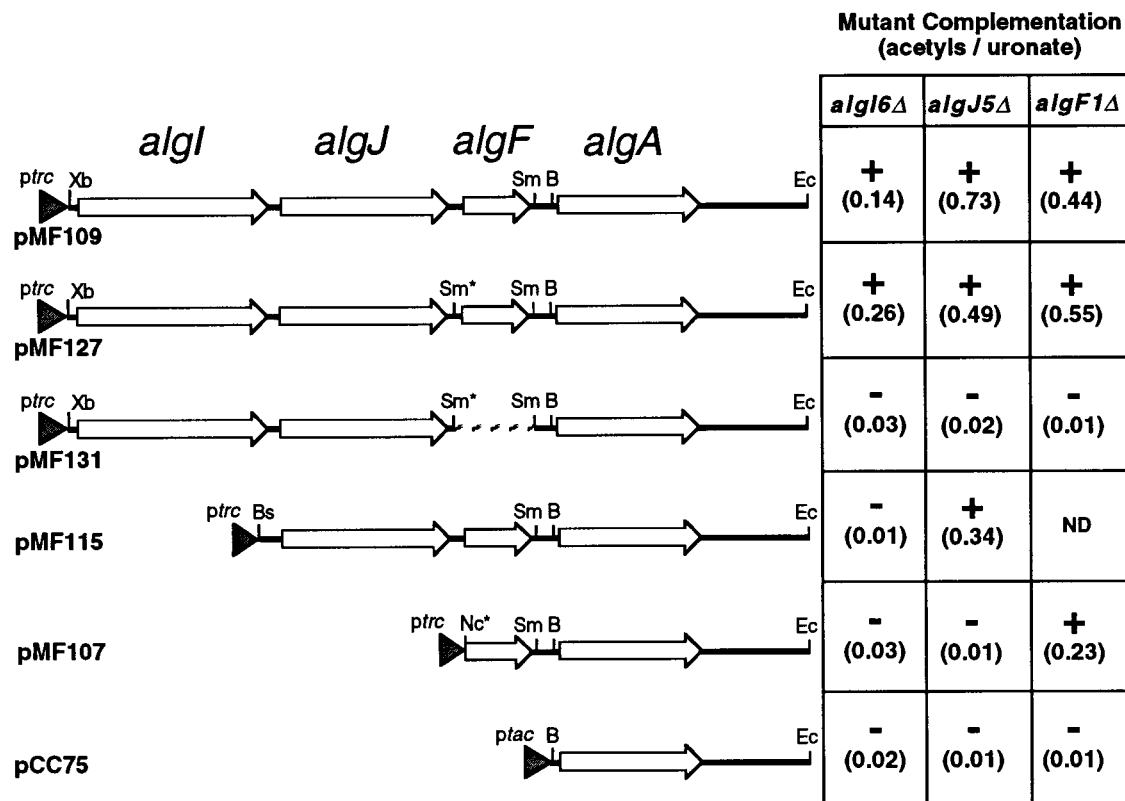

FIG. 7. *P. aeruginosa* DNA in plasmid constructions used to examine the *trans* complementation of the *algF1*Δ::Gm<sup>r</sup> mutation in FRD1156, the *algJ5*Δ::Gm<sup>r</sup> mutation in FRD1154, and the *algI6*Δ::Gm<sup>r</sup> mutation in FRD1155. Complementation is shown as + or - and as the number of acetyls per uronate residue. P<sub>trc</sub> indicates expression under the *trc* (*trp/lac*) promoter. Restriction sites: Xb, *Xba*I; B, *Bam*HI; Sm, *Sma*I; Ec, *Ecl*136 I. Sm\* and Nc\* indicate *Sma*I and *Nco*I, respectively, introduced by mutagenic oligonucleotides.

was mucoid (without providing *algA* in *trans*) and showed an acetylation defect (molar ratio of 0.03). Providing *algFA* in *trans* (pMF107) was not sufficient for complementation, but *algJFA* in *trans* (pMF115) did complement the FRD1153 acetylation defect (molar ratio of 0.68). Thus, FRD1153 appears to be an *algJ* mutant, and the mutant allele was designated *algJ1* (Table 2). All these studies with transposon insertions and point mutants were consistent with the conclusion that the gene products of *algI* and *algJ* (as well as the previously identified *algF*) are required for the acetylation of alginate.

## DISCUSSION

Poly-D-mannuronate appears to be a precursor in the biosynthesis of alginate, and some of the D-mannuronate residues are epimerized to L-guluronate by a polymer-level mannuronan C-5-epimerase encoded by *algG* (12). The D-mannuronate residues can be acetylated at the O-2 and/or O-3 position. In vitro studies show that the *algG*-encoded epimerase (12) and the *algL*-encoded lyase (29) have enzymatic activities that are inhibited if their substrate (poly-D-mannuronate) is acetylated. This suggests that acetylation could be involved in the regulation of alginate structure. To better understand O acetylation of alginate, we recently performed a localized chemical mutagenesis on the alginate biosynthetic operon in mucoid strain FRD, and a mutant, FRD1153, that produced an alginate deficient in acetyl groups was identified (13). Here, we performed a sequence analysis of a 3.7-kb DNA fragment that could complement its acetylation defects, and three ORFs with appropriately positioned ribosome-binding sites were observed

and designated *algJIF*. The *algF* gene has already been associated with alginate acetylation (13, 32), but *algI* and *algJ* have not been previously described. Since these ORFs were within the alginate biosynthetic operon, it was likely that they encoded proteins involved in some aspect of alginate biosynthesis, export, structure, or modification.

To examine the mutant phenotypes of *algI*, *algJ*, and *algF*, we deleted each gene from the chromosome by replacement with a selectable Gm<sup>r</sup> marker. This was performed by employing an IPEX technique. McIver et al. (24) recently showed that gene replacements in *P. aeruginosa* are rare when the selective marker is flanked by a small region (e.g., ~300 bp) of homologous *P. aeruginosa* DNA. The IPEX technique was developed to obtain larger flanking segments of *P. aeruginosa* DNA adjacent to the marked gene and thus improve gene replacement efficiency (24). Here, we inserted the Gm<sup>r</sup> cassette into small fragments of DNA from the alginate biosynthetic operon that were easily manipulated, and these were then used to replace (by homologous recombination) the same gene on a large cosmid clone (i.e., 35 kb in pALG2) containing the entire alginate operon. Following selection for the nonreplicating pALG2::Gm<sup>r</sup> derivatives in *P. aeruginosa*, merodiploids (in which plasmids integrate by a single crossover) were still mucoid since they contained one complete biosynthetic operon as well as one operon interrupted by the Gm<sup>r</sup> cassette (see Fig. 4C). However, the double recombinants were easily distinguished by their nonmucoid phenotype, which resulted from the polar effect of the Gm<sup>r</sup> cassette on the downstream *algA* gene. The frequency of gene replacement was usually >50%,



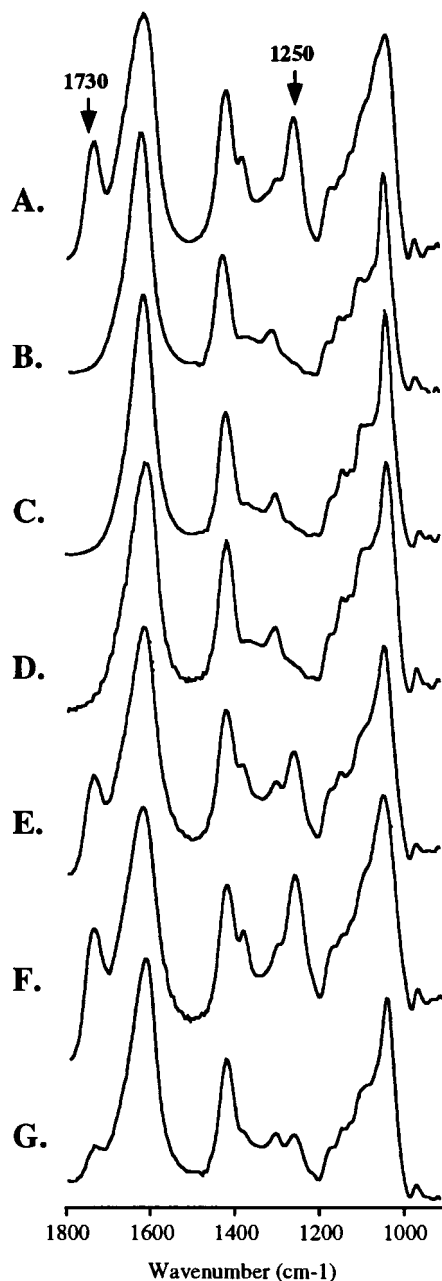

FIG. 8. FT/IR spectra of purified alginates from *P. aeruginosa* FRD strains. Absorbance peaks at 1,730 and 1,250  $\text{cm}^{-1}$  indicate the presence of the acetyl ester bond in alginates from strains (A) FRD1 (wild-type), (B) FRD1156(pCC75), which is *algF1* $\Delta$ ::Gm<sup>r</sup> with *algA* in *trans*, (C) FRD1154(pMF107), which is *algJ5* $\Delta$ ::Gm<sup>r</sup> with *algFA* in *trans*, (D) FRD1155(pMF115), which is *algI6* $\Delta$ ::Gm<sup>r</sup> with *algFA* in *trans*, (E) FRD1156(pMF107), which is *algF1* $\Delta$ ::Gm<sup>r</sup> with *algFA* in *trans*, (F) FRD1154(pMF115), which is *algJ5* $\Delta$ ::Gm<sup>r</sup> with *algJFA* in *trans*, and (G) FRD1155(pMF109), which is *algI6* $\Delta$ ::Gm<sup>r</sup> with *algJFA* in *trans*.

based on the nonmucoid colony morphology among the Gm<sup>r</sup> colonies. In strains selected for further analyses, gene replacement with the Gm<sup>r</sup> cassette was verified by PCR.

All of the mutants generated in this study could be complemented to mucoidy (Alg<sup>+</sup>) by expressing just *algA* in *trans*. Thus, *algI*, *algJ*, and *algF* were not required for alginate polymer formation or its export. A complementation analysis was performed, providing *algJFA* in *trans* under control of the

TABLE 2. Complementation analysis of mutants with chemically or transposon-induced mutations affecting alginate acetylation

Strain (chromosomal mutation)	Plasmid [gene(s) expressed in <i>trans</i> ]	Acetylation of polymer formed <sup>a</sup>
FRD1003 ( <i>algJ</i> ::Tn501-3)	pCC75 ( <i>algA</i> )	–
	pMF107 ( <i>algFA</i> )	–
	pMF115 ( <i>algJFA</i> )	+
FRD1114 ( <i>algI</i> ::Tn501-14)	pCC75 ( <i>algA</i> )	–
	pMF107 ( <i>algFA</i> )	–
	pMF115 ( <i>algJFA</i> )	–
	pMF109 ( <i>algJFA</i> )	+
FRD1153 ( <i>algI</i> )	None	–
	pMF107 ( <i>algFA</i> )	–
	pMF115 ( <i>algJFA</i> )	+

<sup>a</sup> Acetylation was determined by the chemical assay and verified by FT-IR.

strong inducible *trc* promoter (*P<sub>trc</sub>*>*algJFA* [*>* indicates promoter direction]), and we were able to investigate the nature of these genes' involvement in alginate structure. NMR analyses showed that polymers produced by strains deficient in *algI*, *algJ*, or *algF* still contained a mixture of D-mannuronate and L-guluronate, so C-5 epimerization (i.e., D-mannuronate → L-guluronate) was not affected. However, these polymers were not acetylated, indicating that *algI* and *algJ* (as well as *algF*) were both involved in the process of alginate acetylation. A strain missing *algF* (*algF* $\Delta$  with *P<sub>tac</sub>*>*algA* in *trans*) produced an alginate which was not acetylated, whereas *algFA* provided in *trans* restored alginate acetylation. These data confirm similar studies in another mucoid strain in which an *algF* insertion mutation (with *algA* in *trans*) blocked alginate acetylation (32). A strain missing only *algJ* (*algJ* $\Delta$  with *P<sub>trc</sub>*>*algFA* in *trans*) produced alginate which was not acetylated, but expressing *algJFA* in *trans* allowed the production of acetylated alginate, demonstrating that *algJ* was required for acetylation of alginate. These results were verified by complementation of FRD1153 (an *algI* point mutant) when *P<sub>trc</sub>*>*algJ* was provided in *trans*. Finally, a strain missing only *algI* (*algI* $\Delta$  with *P<sub>trc</sub>*>*algJFA* in *trans*) produced nonacetylated alginate, but expressing *algJFA* in *trans* allowed production of an acetylated alginate. These results were verified in FRD1114 (an *algI*::Tn501-14 mutant), which produced nonacetylated and acetylated alginates when *algJFA* and *algJFA* were expressed in *trans*, respectively. Therefore, *algI* and *algJ* represent newly identified genes required for alginate acetylation.

The site of alginate acetylation is unknown, but it could occur in the periplasm, where AlgG acts as a polymer-level C-5-mannuronan epimerase. Although the likely acetyl donor for alginate is acetyl-coenzyme A, we would not expect acetyl-coenzyme A to also localize to the periplasm. If this hypothesis is correct, then alginate probably does not accept the acetyls directly from acetyl-coenzyme A in the cytoplasm. The other components identified in this study may be involved in transport of acetyl groups to the periplasm. The AlgI sequence showed the highest sequence homology (21%) to a protein in *B. subtilis* called Ipa-4r (DltB), which may be a membrane protein and may function in the transport of activated D-alanine through the membrane for the biosynthesis of D-alanyl-lipoteichoic acid (15). AlgI is a rather hydrophobic protein, suggesting a membrane localization, where it may be involved in the transfer of the acetyl groups from the cytoplasmic acetyl-coenzyme A to the periplasm. Interestingly, AlgJ showed striking homology (30% identity and 69% similarity) to the nearby

gene AlgX (25), suggesting that the two genes evolved by gene duplication. Unfortunately, AlgX does not yet have a known function except for its apparent involvement in the late stages of alginate biosynthesis, and so it is not possible to speculate on their commonality in form or function. AlgF did not show any apparent homology with proteins similar to those involved in acetylation. However, the sequence of AlgF predicts a signal sequence, suggesting that it may be processed and exported to the periplasm. In evidence of this, Shinabarger et al. (32) showed that the amino terminus of AlgF produced in *E. coli* is processed at the sequence AQA | DEG, and we have confirmed their observations (unpublished data). Direct evidence for the cellular localization of each of these proteins is presently being investigated, and these results may provide insight as to the mechanism for the transfer of acetyl groups to alginate and the biological significance of this modification of the polymer.

#### ACKNOWLEDGMENTS

We thank Kim Prince (Molecular Resources Center of the University of Tennessee, Memphis) for oligonucleotide synthesis and DNA sequence analysis. We also acknowledge the assistance provided by John Miller (Department of Pharmacology, University of Tennessee, Memphis) in the <sup>1</sup>H-NMR spectral analyses of alginates.

This work was supported by Veterans Administration Medical Research Funds (D.E.O.) and in part by Public Health Service grant AI-19146 from the National Institute of Allergy and Infectious Diseases (D.E.O.).

#### REFERENCES

1. Bagdasarian, M. M., E. Amann, R. Lurz, B. Rueckert, and M. Bagdasarian. 1983. Activity of the hybrid *trp-lac* (*tac*) promoter of *Escherichia coli* in *Pseudomonas putida*: construction of broad-host-range, controlled expression vectors. *Gene* **26**:273–282.
2. Baltimore, R. S., and M. Mitchell. 1982. Immunologic investigations of mucoid strains of *Pseudomonas aeruginosa*: comparison of susceptibility to opsonic antibody in mucoid and nonmucoid strains. *J. Infect. Dis.* **141**:238–247.
3. Boyd, A., M. Ghosh, T. B. May, D. Shinabarger, R. Keogh, and A. M. Chakrabarty. 1993. Sequence of the *algL* gene of *Pseudomonas aeruginosa* and purification of its alginate lyase product. *Gene* **131**:1–8.
4. Chitnis, C. E., and D. E. Ohman. 1990. Cloning of *Pseudomonas aeruginosa algG*, which controls alginate structure. *J. Bacteriol.* **172**:2894–2900.
5. Chitnis, C. E., and D. E. Ohman. 1993. Genetic analysis of the alginate biosynthetic gene cluster of *Pseudomonas aeruginosa* shows evidence of an operonic structure. *Mol. Microbiol.* **8**:583–590.
6. Chu, L., T. B. May, A. M. Chakrabarty, and T. K. Misra. 1991. Nucleotide sequence and expression of the *algE* gene involved in alginate biosynthesis by *Pseudomonas aeruginosa*. *Gene* **107**:1–10.
7. Davidson, J. W., C. J. Lawson, and I. W. Sutherland. 1977. Localization of O-acetyl groups in bacterial alginate. *J. Gen. Microbiol.* **98**:603–606.
8. DeVries, C. A., and D. E. Ohman. 1994. Mucoid-to-nonmucoid conversion in alginate-producing *Pseudomonas aeruginosa* often results from spontaneous mutations in *algT*, encoding a putative alternative sigma factor, and shows evidence for autoregulation. *J. Bacteriol.* **176**:6677–6687.
9. Evans, L. R., and A. Linker. 1973. Production and characterization of the slime polysaccharide of *Pseudomonas aeruginosa*. *J. Bacteriol.* **116**:915–924.
10. Figurski, D., and D. R. Helinski. 1979. Replication of an origin-containing derivative of plasmid RK2 dependent on a plasmid function provided in *trans*. *Proc. Natl. Acad. Sci. USA* **76**:1648–1652.
11. Flynn, J. L., and D. E. Ohman. 1988. Use of a gene replacement cosmid vector for cloning alginate conversion genes from mucoid and nonmucoid *Pseudomonas aeruginosa* strains: *algS* controls expression of *algT*. *J. Bacteriol.* **170**:3228–3236.
12. Franklin, M. J., C. E. Chitnis, P. Gacesa, A. Sonesson, D. C. White, and D. E. Ohman. 1994. *Pseudomonas aeruginosa* AlgG is a polymer level alginate C5-mannuronan epimerase. *J. Bacteriol.* **176**:1821–1830.
13. Franklin, M. J., and D. E. Ohman. 1993. Identification of *algF* in the alginate biosynthetic gene cluster of *Pseudomonas aeruginosa* which is required for alginate acetylation. *J. Bacteriol.* **175**:5057–5065.
14. Gacesa, P. 1988. Alginates. *Carbohydr. Polym.* **8**:161–182.
15. Glaser, P., F. Kunst, M. Arnaud, M.-P. Coudart, W. Gonzales, M.-F. Hullo, M. Ionescu, B. Lubochinsky, L. Marcelino, I. Moszer, E. Presecan, M. Santana, E. Schneider, J. Schweizer, A. Vertes, G. Rapoport, and A. Danchin. 1993. *Bacillus subtilis* genome project: cloning and sequencing of the 97 kb region from 325° to 333°. *Mol. Microbiol.* **10**:371–384.
16. Govan, J. R. W., and G. S. Harris. 1986. *Pseudomonas aeruginosa* and cystic fibrosis: unusual bacterial adaptation and pathogenesis. *Microbiol. Sci.* **3**:302–308.
17. Hestrin, S. 1949. The reaction of acetylcholine and other carboxylic acid derivatives with hydroxylamine and its analytical application. *J. Biol. Chem.* **180**:249–261.
18. Knutson, C. A., and A. Jeanes. 1968. A new modification of the carbazole analysis: application to heteropolysaccharides. *Anal. Biochem.* **24**:470–481.
19. Maniatis, T., E. F. Fritsch, and J. Sambrook. 1982. *Molecular cloning: a laboratory manual*. Cold Spring Harbor Laboratory, Cold Spring Harbor, N.Y.
20. Marcus, H., and N. R. Baker. 1985. Quantitation of adherence of mucoid and nonmucoid *Pseudomonas aeruginosa* to hamster tracheal epithelium. *Infect. Immun.* **47**:723–729.
21. Martin, D. W., M. J. Schurr, H. Yu, and V. Deretic. 1994. Analysis of promoters controlled by the putative sigma factor AlgU regulating conversion to mucoidy in *Pseudomonas aeruginosa*: relationship to  $\sigma^E$  and stress response. *J. Bacteriol.* **176**:6688–6696.
22. May, T. B., D. Shinabarger, A. Boyd, and A. M. Chakrabarty. 1994. Identification of amino acid residues involved in the activity of phosphomannose isomerase-guanosine 5'-diphospho-D-mannose pyrophosphorylase, a bifunctional enzyme in the alginate biosynthetic pathway of *Pseudomonas aeruginosa*. *J. Biol. Chem.* **269**:4872–4877.
23. May, T. B., D. Shinabarger, R. Maharaj, J. Kato, L. Chu, J. D. DeVault, S. Roychoudhury, N. A. Zielinski, A. Berry, R. K. Rothmel, T. K. Misra, and A. M. Chakrabarty. 1991. Alginate synthesis by *Pseudomonas aeruginosa*: a key pathogenic factor in chronic pulmonary infections of cystic fibrosis patients. *Clin. Microbiol. Rev.* **4**:191–206.
24. McIver, K. S., E. Kessler, J. C. Olson, and D. E. Ohman. 1995. The elastase propeptide functions as an intramolecular chaperone required for elastase activity and secretion in *Pseudomonas aeruginosa*. *Mol. Microbiol.* **18**:877–889.
25. Monday, S. R., and N. L. Schiller. 1996. Alginate synthesis in *Pseudomonas aeruginosa*: the role of AlgL (alginate lyase) and AlgX. *J. Bacteriol.* **178**:625–632.
26. Ohman, D. E., and A. M. Chakrabarty. 1981. Genetic mapping of chromosomal determinants for the production of the exopolysaccharide alginate in a *Pseudomonas aeruginosa* cystic fibrosis isolate. *Infect. Immun.* **33**:142–148.
27. Ramphal, R., and G. B. Pier. 1985. Role of *Pseudomonas aeruginosa* mucoid exopolysaccharide in adherence to tracheal cells. *Infect. Immun.* **47**:1–4.
28. Rehm, B. H., G. Boheim, J. Tommassen, and U. K. Winkler. 1994. Overexpression of *algE* in *Escherichia coli*: subcellular localization, purification, and ion channel properties. *J. Bacteriol.* **176**:5639–5647.
29. Schiller, N. L., S. R. Monday, C. M. Boyd, N. T. Keen, and D. E. Ohman. 1993. Characterization of the *Pseudomonas aeruginosa* alginate lyase gene (*algL*): cloning, sequencing, and expression in *Escherichia coli*. *J. Bacteriol.* **175**:4780–4789.
30. Schwarzmann, S., and J. R. Boring III. 1971. Antiphagocytic effect of slime from a mucoid strain of *Pseudomonas aeruginosa*. *Infect. Immun.* **3**:762–767.
31. Schweizer, H. P. 1993. Small broad-host-range gentamicin resistance gene cassettes for site-specific insertion and deletion mutagenesis. *Biotechniques* **15**:831–833.
32. Shinabarger, D., T. B. May, A. Boyd, M. Ghosh, and A. M. Chakrabarty. 1993. Nucleotide sequence and expression of the *Pseudomonas aeruginosa algF* gene controlling acetylation of alginate. *Mol. Microbiol.* **9**:1027–1035.
33. Simpson, J. A., S. E. Smith, and R. T. Dean. 1988. Alginate inhibition of the uptake of *Pseudomonas aeruginosa* by macrophages. *J. Gen. Microbiol.* **134**:29–36.
34. Skjåk-Bræk, G., H. Grasdalen, and B. Larsen. 1986. Monomer sequence and acetylation pattern in some bacterial alginates. *Carbohydr. Res.* **154**:239–250.
35. Skjåk-Bræk, G., F. Zanetti, and S. Paoletti. 1989. Effect of acetylation on some solution and gelling properties of alginates. *Carbohydr. Res.* **185**:131–138.
36. West, S. E., H. P. Schweizer, C. Dall, A. K. Sample, and L. J. Runyen-Janecky. 1994. Construction of improved *Escherichia-Pseudomonas* shuttle vectors derived from pUC18/19 and sequence of the region required for their replication in *Pseudomonas aeruginosa*. *Gene* **148**:81–86.
37. Zielinski, N. A., A. M. Chakrabarty, and A. Berry. 1991. Characterization and regulation of the *Pseudomonas aeruginosa algC* gene encoding phosphomannomutase. *J. Biol. Chem.* **266**:9754–9763.