

# The *WH11* Gene of *Candida albicans* Is Regulated in Two Distinct Developmental Programs through the Same Transcription Activation Sequences

THYAGARAJAN SRIKANTHA, LUONG K. TSAI, AND DAVID R. SOLL\*

Department of Biological Sciences, University of Iowa, Iowa City, Iowa 52242

Received 19 December 1996/Accepted 4 April 1997

***Candida albicans* strain WO-1 undergoes two developmental programs, the bud-hypha transition and high-frequency phenotypic switching in the form of the white-opaque transition. The *WH11* gene is expressed in the white budding phase but is inactive in the white hyphal phase and in the opaque budding phase. *WH11* expression, therefore, is regulated in the two developmental programs. Through fusions between deletion derivatives of the *WH11* promoter and the newly developed *Renilla reniformis* luciferase, the *WH11* promoter has been characterized in the two developmental programs. Three transcription activation sequences, two strong and one weak, are necessary for the full expression of *WH11* in the white budding phase, but no negative regulatory sequences were revealed as playing a role in either the white hyphal phase or the opaque budding phase. These results suggest that regulation is solely through activation in the white budding phase and the same mechanism, therefore, is involved in regulating the differential expression of *WH11* in the alternative white and opaque phases of switching and the budding and hyphal phases of dimorphism.**

*Candida albicans* and a number of related species possess two well-defined developmental programs, the bud-hypha transition (16) and high-frequency phenotypic switching (17). In the bud-hypha transition, cells differentiate from a round, budding growth form to an elongate hyphal growth form, the latter composed of sequential cellular compartments. The hyphal growth form represents a morphological modification which apparently facilitates foraging and tissue penetration. In the program of high-frequency phenotypic switching, cells switch spontaneously and reversibly between a number of general phenotypes distinguishable by alterations in colony morphology. Phenotypic switching can also have extreme pleiotropic consequences on cellular phenotype (2, 15, 17, 19, 20).

Although the bud-hypha transition and high-frequency phenotypic switching represent two distinguishable developmental programs, there are several indications in the most thoroughly analyzed switching system, the white-opaque transition in strain WO-1 (15), that the regulatory circuitry in the two programs partially overlaps. First, opaque-phase cells, like hyphae, are elongate, and each contains a large vacuole similar to the one observed in each hyphal compartment (2). Second, opaque-phase cells express one or more hypha-specific surface antigens, although they also express opaque-phase-specific surface antigens (1). Third, an analysis of the transition from white to opaque at the single-cell level suggested a pseudohyphal intermediate (4, 20). Finally, the white-phase-specific gene *WH11* is not only under the control of the white-opaque transition but also under the control of the bud-hypha transition (25). *WH11* is expressed in the budding white phase but is inactive after cells have differentiated to a hypha or have switched to the opaque phase. Wh11 is homologous to the glucose lipid-regulated protein Glp1p of *Saccharomyces cerevisiae* (26), which has also been identified as heat shock protein HSP12 (9), and is distributed throughout the cytoplasm of white budding *C. albicans* cells (14). The Wh11 protein is

undetectable in opaque-phase cells and in white budding cells which have just formed hyphae (14).

A functional characterization of the *WH11* promoter in the two phases of the white-opaque transition using a transcriptional reporter system revealed two transcription activation sequences (22). Deletion of the distal sequence resulted in a 6-fold reduction in *WH11* transcription, deletion of the proximal sequence resulted in a 15-fold reduction, and deletion of both resulted in the apparent elimination of *WH11* transcription (22). In the analysis of deletion derivatives, there was absolutely no indication of negative regulatory sequences functioning in the opaque phase (22), leading to a relatively simple model in which the regulation of *WH11* is through the synthesis or activation of white-phase-specific *trans*-acting factors (19). In the white phase, these factors are differentially expressed or activated and interact with the two transcription activation sequences of the *WH11* promoter, resulting in *WH11* transcription. In the opaque phase, these factors are not expressed or activated, and *WH11* is, therefore, not transcribed. To test whether this simple model is sufficient to account for the regulation of *WH11* in the budding and hyphal phases of growth as well, a deletion analysis was performed. In this case, a more sensitive reporter system, employing the *Renilla reniformis* luciferase (RLUC) (23), which contains no leucines (6), was used, thus eliminating the problem of misreading CUG codons as serines (8, 12, 13). The results demonstrate that the same simple model of regulation of *WH11* transcription is applicable to both developmental programs.

## MATERIALS AND METHODS

**Strain maintenance and transformation.** Red 3/6, an *ade2* derivative of *C. albicans* strain WO-1 (22, 24), was used in all aspects of this study. Subculturing, growth, generation of spheroplasts, transformation, and the maintenance of transformants were performed according to methods previously described (22-24). In all cases, cells were grown in supplemented Lee's medium (3).

**Construction of deletion derivatives of the *WH11* promoter in transcriptional fusions.** Transcriptional fusions contained deletion derivatives of the *WH11* promoter (22) fused directly to *RLUC* (23), resulting in the synthesis of a heterologous *RLUC* protein following activation. Deletion constructs were generated in pCRW3, which contains the *C. albicans ADE2* gene for the selection of Red 3/6 transformants, and a multiple cloning site preceding *RLUC* (23). Two

\* Corresponding author. Mailing address: Department of Biological Sciences, 138 BB, University of Iowa, Iowa City, IA 52242. Phone: (319) 335-1117. Fax: (319) 335-2772.

TABLE 1. Specific activity of RLuc in the white and opaque phases of *C. albicans* strain WO-1 (Red 3/6) containing various deletions of the upstream regulatory region of *WH11* fused to *RLUC* (transcriptional fusion)

Promoter construct <sup>a</sup>	Phase <sup>b</sup>	No. of clones analyzed	RLUC sp act (10 <sup>-2</sup> U/ $\mu$ g of protein)	Fold increase over pCRW3 <sup>c</sup>	Fold difference, W/O <sup>d</sup>	Fold decrease due to deletion <sup>e</sup>
1 pCRW3	W	2	0.42 $\pm$ 0.01			
	O	2	0.40 $\pm$ 0.01			
2 pCRW5 $\Delta$ 6 -475 P C F	W	5	8,600 $\pm$ 640	21,000	200	
	O	5	42 $\pm$ 3.5			
3 pCRW5 $\Delta$ 7 -388 C F	W	4	940 $\pm$ 71	2,200	200	9
	O	4	4.8 $\pm$ 0.58			
4 pCRW5 $\Delta$ R11 -305 C F	W	2	710 $\pm$ 25	1,700	210	12
	O	2	3.3 $\pm$ 1.4			
5 pCRW5 $\Delta$ R10 -238 C F	W	2	11 $\pm$ 0.35	26		780
	O	2	0.56 $\pm$ 0.09			
6 pCRW5 $\Delta$ 10 -200 F	W	3	1.1 $\pm$ 0.09	3		7,900
	O	3	0.50 $\pm$ 0.05			
7 pCRW5 $\Delta$ 39 -124 F	W	2	1.3 $\pm$ 0.10	3		6,600
	O	2	0.48 $\pm$ 0.05			
8 pCRW5 $\Delta$ Af -85	W	2	0.91 $\pm$ 0.08	2		9,500
	O	2	0.39 $\pm$ 0.05			
9 pCRW5 $\Delta$ 6HS2 -475 F $\Delta$ -378 to -305	W	3	6,000 $\pm$ 320	14,000	210	
	O	3	29 $\pm$ 1.3			
10 pCRW5 $\Delta$ 6HS3 -475 F $\Delta$ -378 to -83	W	2	309 $\pm$ 41	740	130	28
	O	2	2.4 $\pm$ 0.26			

<sup>a</sup> Constructs 2 through 8 each contain a 5' terminal deletion of the promoter as noted. Constructs 9 and 10 contain internal deletions of the promoter as noted. P, *Spe*I; C, *Scal*I; F, *Afl*III; unfilled triangles, heat shock elements; filled square, TATA box; dotted rectangle, *WH11* 5' untranslated region; unfilled rectangle, *RLUC* open reading frame.

<sup>b</sup> W, white phase; O, opaque phase.

<sup>c</sup> In this case, only values for white phase were used.

<sup>d</sup> The white/opaque difference was not computed when RLuc specific activity in a phase was within 50% of the pCRW3 level, which, in this case, was considered background.

<sup>e</sup> Fold decrease in activity compared to the activity with the full promoter.

specific deoxynucleotide primers, ARS4 (5' TACCGTGTGGTGTGTC 3') and WPS (5' TTCTGCAGGTTTAATTGTTCTGT 3'), were used to generate PCR products containing various deletion derivatives of the *WH11* 5' upstream region. ARS4 contained a *Kpn*I site (GGTACC), and WPS contained a *Pst*I site (CTGCAG). The majority of PCR products were derived directly from the *WH11*-firefly luciferase (*lux*) chimeric constructs used in the previous study for the functional characterization of the *WH11* promoter in the white and opaque phases of the white-opaque transition (22). The *WH11*-*lux* deletion derivative plasmids pWF20 $\Delta$ 6, pWF20 $\Delta$ 7, pWF20 $\Delta$ R10, pWF20 $\Delta$ 10, and pWF20 $\Delta$ AF (22) were used as templates to derive PCR fragments for pCRW5 $\Delta$ 6, pCRW5 $\Delta$ 7, pCRW5 $\Delta$ R11, pCRW5 $\Delta$ 10, and pCRW5 $\Delta$ Af, respectively (Table 1). The plasmid pCRW5 $\Delta$ R10 (Table 1) was derived by inserting into the multiple cloning site of pCRW3 a PCR product spanning the -238 to +60 bp region of the *WH11* gene. This PCR product was generated with two deoxynucleotide primer pairs, NFKpn (5' GGGGTACCGGCACTTGATTTCCAGTA 3') and WPS, and with pWF20 $\Delta$ 6 as a template. The product was digested with *Kpn*I and *Pst*I, gel purified, and inserted between the *Kpn*I and *Pst*I sites of pCRW3. The plasmid pCRW5 $\Delta$ 39 (Table 1) was derived by first generating a PCR product spanning the -124 to +60 bp region of the *WH11* gene with two deoxynucleotide primers, CAKpn (5' GGGGTACCTACAATAGTGGTGG 3') and WPS. The PCR product was then inserted into pCRW3 as described for the pCRW5 $\Delta$ R10 plasmid. Plasmids pCRW5 $\Delta$ 6HS2 and pCRW5 $\Delta$ 6HS3 (Table 1) were derived by cloning a PCR product generated from the templates pWF20 $\Delta$ 6HS2 and pWF20 $\Delta$ 6HS3 (22), respectively, with the primer pairs *Kpn*5-2 (5' GGGGTACCATCCTCGGGATCTGCA 3') and WPS. The orientation of inserts in plasmid

derivatives was confirmed in each case by sequencing by the dideoxy sequencing method (11) with Sequenase version II (U.S. Biochemicals, Cleveland, Ohio). Red 3/6 transformants harboring the different deletion derivatives were generated by site-specific integrative transformation of *Nsi*I-linearized plasmids targeted to the *ADE2* locus (24). The presence of integrated plasmid in transformants was confirmed both by a dot blot assay and by Southern blot hybridization.

**Construction of deletion derivatives of the *WH11* promoter in translational fusions.** Select transcriptional fusion derivatives were converted into translational fusion derivatives by inserting in frame a 195-bp PCR fragment containing the *WH11* coding region at the 5' end of the *RLUC* coding region, resulting in the synthesis of a fusion protein of *RLUC* and *WH11* when activated. The resulting plasmid derivatives included pCWOR5 $\Delta$ 6, derived from pCRW5 $\Delta$ 6; pCWOR5 $\Delta$ 7, derived from pCRW5 $\Delta$ 7; pCWOR5 $\Delta$ 10, derived from pCRW5 $\Delta$ 10; pCWOR5 $\Delta$ AF, derived from pCRW5 $\Delta$ Af; and pCWOR5 $\Delta$ 6HS3, derived from pCRW5 $\Delta$ 6HS3.

**Temperature-induced mass conversion from the opaque to the white phenotype.** To monitor RLuc activity during mass conversion from the opaque to the white phase in cells in which *RLUC* was under the control of the entire functional *WH11* promoter, red 3/6 cells harboring either pCRW5 $\Delta$ 6 or pCWOR5 $\Delta$ 6 were grown in 25 ml of supplemented Lee's medium at 25°C to 10<sup>7</sup> cells per ml. This culture was diluted 2:1 with fresh supplemented Lee's medium prewarmed to 42°C (7, 25). Cultures were then rotated at 200 rpm in a gyratory water bath shaker at 42°C. Parallel samples were removed at time intervals to measure luciferase activity and the proportions of opaque- and white-phase cells. For measuring RLuc activity in white- versus opaque-phase cells harboring deletion derivatives of the *WH11* promoter fused to *RLUC*, cells from transformant

colonies exhibiting the alternative phenotypes were grown to final densities of  $5 \times 10^7$  to  $10 \times 10^7$  cells per ml at 25°C in 12.5 ml of supplemented Lee's medium.

**Induction of synchronous bud or hypha formation under the regime of pH-regulated dimorphism.** To monitor RLuc activity in budding and hypha-forming populations of cells in which *RLUC* was under the control of the entire functional *WH11* promoter, Red 3/6 cells harboring either pCRW5Δ6 or pCWOR5Δ6 were grown in supplemented Lee's medium at 25°C to stationary phase. After 24 h in stationary phase, cells were pelleted, washed in phosphate buffer prewarmed to 25°C, diluted to  $6 \times 10^6$  spheres per ml in 12.5 ml of supplemented Lee's medium prewarmed to 37°C, and adjusted to either pH 4.5, to induce bud formation, or pH 6.5, to induce hypha formation (5, 16). Cultures were rotated at 200 rpm, and parallel samples were removed at time intervals to measure luciferase activity and the kinetics of bud or hypha formation. To induce hypha formation in the presence of serum, 10% adult goat serum was added to supplemented Lee's medium (pH 6.5). For measuring RLuc activity in budding and hypha-forming cells harboring deletion derivatives of the *WH11* promoter fused to *RLUC*, budding and hypha-forming cells were harvested 300 min after dilution into respective media at 37°C.

**Assay for luciferase activity.** The preparation of cell-free extracts and the method for measuring luciferase activity with a luminometer have been described in detail elsewhere (23). Activity is presented as relative luminescence per 10 s per microgram of protein. This represents arbitrary units not normalized to a standard for light emission. Protein was measured by the Bradford assay (Bio-Rad Laboratories, Hercules, Calif.).

## RESULTS

***WH11* promoter function during temperature-induced mass conversion from the opaque to the white phase.** When the temperature of an opaque-phase culture is raised from 25 to 42°C, cells convert semisynchronously and en masse from the opaque to the white phase (4, 10, 15, 25). Mass conversion occurs in association with the second semisynchronous round of cell multiplication, and this corresponds to the activation of *WH11* transcription (25). The expression of *RLUC* under *WH11* promoter regulation was monitored during mass conversion to test whether the appearance of RLuc activity corresponds to the increase in *WH11* transcript previously described (25). Opaque-phase cells in which the transcriptional fusion derivative plasmid pCRW5Δ6 was integrated at the *ADE2* locus were shifted from 25 to 42°C, and samples were removed from the culture at time intervals after the temperature shift to assay for cell density, cell phenotype (opaque versus white), and RLuc activity (Fig. 1A). The concentration of cells doubled after 3, 5, and 8 h. White-phase cells appeared semisynchronously in the population between 3 and 5 h, concomitant with the second cell doubling. RLuc activity began to increase at 3 h, concomitant with the beginning of the second round of cell doublings, the appearance of white-phase cells, and the appearance of endogenous *WH11* transcript (25). Similar results were obtained during mass conversion of cells transformed with pCWOR5Δ6, which contained a translational fusion of the *WH11* open reading frame and *RLUC* under the regulation of the functional *WH11* promoter (Fig. 1B).

***WH11* promoter function during semisynchronous conversion from the bud to the hyphal phenotype.** It was previously demonstrated that cells which formed buds at pH 4.5 contained both the *WH11* transcript (25) and *WH11* protein (14), but cells which formed hyphae at pH 6.7 contained neither transcript (25) nor protein (14). To characterize the kinetics of the loss of RLuc activity in a cell population induced to form hyphae, cells harboring the transcriptional fusion derivative pCRW5Δ6 were analyzed under the regime of pH-regulated dimorphism. At pH 4.5, cells evaginated semisynchronously, with an average evagination time of 140 min (Fig. 2A). By 225 min, over 90% of the population had evaginated, and all evaginations grew as round-to-ellipsoidal buds. The specific activity of RLuc remained relatively constant at approximately  $4 \times 10^5$  U per  $\mu\text{g}$  of protein through 300 min (Fig. 2A). The evagination kinetics of cells induced to form hyphae at pH 6.5

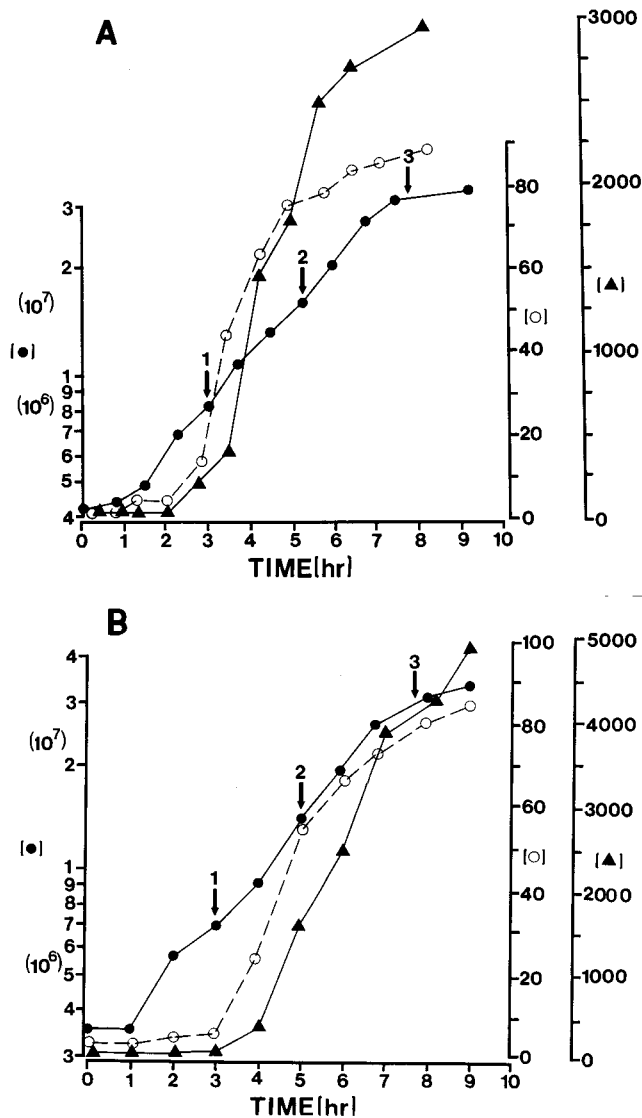

FIG. 1. Specific activity of *Renilla luciferase* during temperature-induced mass conversion from the opaque to the white phase in *C. albicans* strain Red 3/6 transformed with *RLUC* under the regulation of the functional *WH11* promoter. (A) Transcriptional fusion (pCRW5Δ6) in which the Δ6 *WH11* promoter is fused directly to *RLUC*; (B) translational fusion (pCWOR5) in which the *WH11* open reading frame is fused in frame to *RLUC* under the regulation of the *WH11* promoter. Symbols: ●, cell concentration; ○, proportion of white cells in the population; ▲, specific activity of RLuc, presented as relative luminescence per 10 s per microgram of protein. Numbers with arrows indicate rounds of cell doubling.

(Fig. 2B) were similar to those of cells induced to form buds at pH 4.5 (Fig. 2A). Cells evaginated semisynchronously, with an average evagination time of 145 min, and over 90% of the population had evaginated by 225 min. The specific activity of RLuc remained relatively constant between 0 and 120 min, then decreased precipitously to 5% of the original specific activity by 180 min. The kinetics of the reduction in RLuc specific activity were roughly inverse to the appearance of evaginations in the population (Fig. 2B). The time at which the specific activity of RLuc had decreased by 50% was 130 min, which is very close to the time at which 50% of cells had formed hyphae, 140 min (Fig. 2B). The residual level of RLuc activity at 180 min was similar to the proportion of cells in the

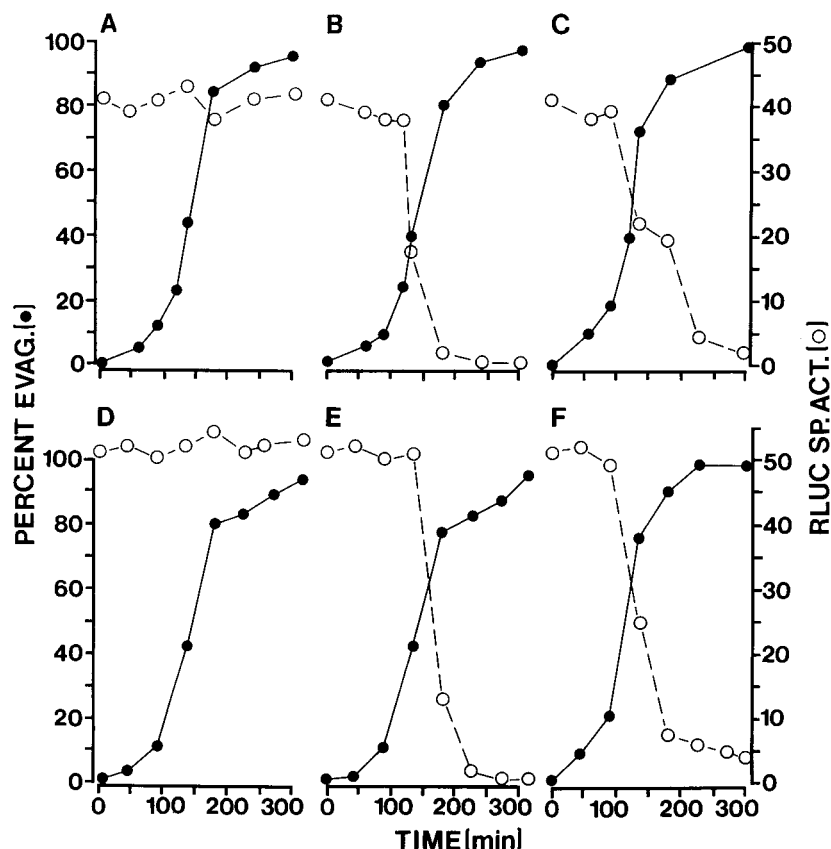

FIG. 2. Specific activity of *Renilla luciferase* during pH-regulated dimorphism in *C. albicans* strain Red 3/6 transformed with a plasmid in which *RLUC* is under the regulation of the functional *WH11* promoter. (A) Transcriptional fusion (pCRW5Δ6) forming buds at pH 4.5; (B) transcriptional fusion forming hyphae at pH 6.7; (C) transcriptional fusion forming hyphae at pH 6.5 in the presence of 10% goat serum; (D) translational fusion (pCWOR5Δ6) forming buds at pH 4.5; (E) translational fusion forming hyphae at pH 6.5; (F) translational fusion forming hyphae at pH 6.7 in the presence of 10% goat serum. Symbols: ●, percent cells which have evaginated; ○, RLUC specific activity, presented as relative luminescence per 10 s per microgram of protein.

population which formed buds rather than hyphae. Similar results were obtained when RLUC activity was monitored in budding and hypha-forming cells containing the translational fusion pCRWOR5Δ6 (Fig. 2D and E).

Hyphae formed at pH 6.5 under the regime of pH-regulated dimorphism sometimes swell, and a significant proportion exhibits a pseudohyphal shape (5). The addition of 10% goat serum to cultures at pH 6.5, however, results in the growth of narrow, more traditionally shaped hyphae. RLUC activity was, therefore, also monitored after stationary-phase cells were diluted into fresh medium at pH 6.5 containing 10% goat serum. Again, the decrease in RLUC activity was roughly inverse to the appearance of evaginations in the population (Fig. 2C). Similar results were obtained with the translational fusion construct pCRWOR5Δ6 (Fig. 2F).

**Functional characterization of the *WH11* promoter in the white and opaque phases by using the *RLUC* reporter system.** The full-length promoter originally characterized in white- and opaque-phase cells with the transcription-based reporter system included the 1,200 bp immediately upstream of the *WH11* transcription initiation site (22). The white-phase-specific distal activation sequence was determined in the previous study to be between -475 and -388 bp, and the white-phase-specific proximal activation sequence was determined to be between -307 and -270 bp (Fig. 3A). The deletion derivative pCRW5Δ6, which contained -475 to -1 bp of the *WH11* promoter, exhibited maximal expression of RLUC in the white

phase, which was more than 20,000 times higher than that of cells transformed with pCRW3, which contained no *WH11* promoter sequences (Table 1). Cells transformed with pCRW5Δ6 exhibited a 200-fold difference between white- and opaque-phase expression (Table 1). The transformant containing pCWOR5Δ6, which represents the translational fusion derivative corresponding to pCRW5Δ6, exhibited a similar high level of RLUC activity in the white phase and a similar difference (156-fold) between white- and opaque-phase cells (data not shown). Cells transformed with pCRW5Δ7, which lacks an additional 88 bp between -475 and -388 bp, exhibited a ninefold reduction in RLUC activity compared to cells in the white phase transformed with pCRW5Δ6 (Table 1). This corresponded to the sixfold reduction observed in cells transformed with the corresponding deletion constructs and analyzed with the transcriptional reporter system (22). The translational fusion derivative pCWOR5Δ7, which corresponds to pCRW5Δ7, exhibited a similar ninefold reduction compared to pCWOR5Δ6 and a similar differential between the white- and opaque-phase cells (data not shown). Cells transformed with pCRW5ΔR11, which lacks an additional 83 bp between -388 and -305 bp, had relatively little additional effect on luciferase activity in the white or the opaque phase (Table 1). However, cells with pCRW5ΔR10, which lacks an additional 67 bp between -305 and -238 bp, resulted in a further reduction of 780-fold in RLUC activity in the white phase (Table 1). A similar decrease was observed in the translational fusion de-

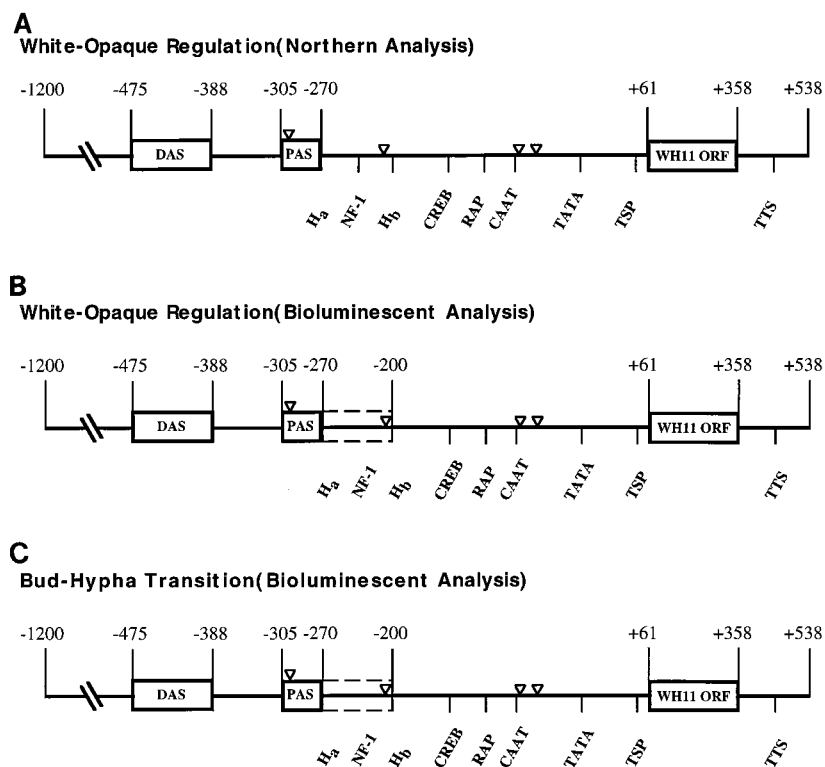

FIG. 3. Diagrams of the transcription activation sequences which regulate the expression of *WH11* during the white-opaque transition and the bud-hypha transition. DAS, strong distal activation sequence; PAS, strong proximal activation sequence; dashed box, weak activation domain; WH11 ORF, *WH11* open reading frame; triangles, a repeat sequence in the promoter region;  $H_{\alpha}$  and  $H_{\beta}$ , heat shock consensus sequences; NF-1, CREB, and RAP, sequences homologous to known regulatory sequences in the promoters of genes in other organisms (22); CCAAT and TATA, respective regulatory boxes; TSP, transcription start sequence; TTS, transcription termination sequence. Note that the same strong activation sequences and the same weak activation domain regulate *WH11* transcription in both developmental programs. Note also that the functional analysis with the transcription reporter (Northern analysis) was not sensitive enough to reveal the weak activation domain.

relative pCWOR5Δ10 (data not shown). This corresponded to the nearly complete elimination of *WH11-FLUC* transcription observed in cells transformed with the corresponding deletion construct and analyzed with the transcriptional reporter system (22). Although the putative distal and proximal activation sequences were missing in pCRW5ΔR10, transformants harboring the deletion derivative pCRW5ΔR10 still expressed RLUC activity in the white phase at a level 26-fold higher than transformants harboring the promoterless plasmid pCRW3 and 20-fold higher than the levels expressed in the opaque phase (Table 1). These levels of expression were not resolved previously with the less quantitative transcription-based reporter system (22) and suggest that there is an additional weak transcription activation sequence proximal to the strong proximal activation sequence. A deletion between -238 and -200 bp in pCRW5Δ10 reduced RLUC activity further to a level only three-fold higher than that of the promoterless plasmid pCRW3, and deletions between -200 and -124 bp in pCRW5Δ39, and between -124 and -85 bp in pCRW5ΔAf, resulted in no further effect (Table 1). Similar results were obtained with comparable translational fusion derivatives (data not shown).





The selective deletion of the distal activation sequence in pCRW5Δ7 resulted in a ninefold reduction in RLUC activity in the white phase (Table 1), and a similar result was obtained with the translational deletion derivative pCWOR5Δ7 (data not shown). To test the effect of the selective deletion of the major proximal activation sequence, a deletion was constructed in pCRW5Δ6 between -378 and -83 bp to generate pCRW5Δ6HS3 (Table 1). Cells transformed with pCRW5Δ6HS3 exhib-

ited a 28-fold reduction in RLUC activity in the white phase (Table 1). This was still 740 times greater than activity in the transformant harboring the promoterless plasmid pCRW3 and 130 times greater than that in cells in the opaque phase (Table 1). Similar results were obtained with the corresponding translational fusion, pCWOR5Δ6HS3 (data not shown). On the other hand, a deletion of a region between the major distal and proximal activation sequences between -378 and -305 bp in pCRW5Δ6HS2 had only a minimal effect on activity (Table 1).

Therefore, the deletion analysis of the 5' upstream region of *WH11* using the *RLUC* reporter system in the white and opaque phases confirmed the positions and relative strengths of the major distal and proximal activation sequences originally identified by the transcriptional reporter analysis (22) and, in addition, identified a weak proximal activation sequence (compare Fig. 3A and B).

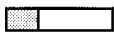
**Functional characterization of the *WH11* promoter in the bud and hypha phenotypes by using the *RLUC* reporter system.** To analyze promoter function in budding and hypha-forming cells, RLUC activity was measured in cells harboring the various deletion derivatives during stationary phase (0 min), after bud formation at pH 4.5 (300 min), and after hypha formation at pH 6.5 (300 min) (Table 2). For cells transformed with pCRW5Δ6, which contains -475 to -1 bp of the *WH11* promoter, similar levels of RLUC were expressed in stationary-phase cells and in cells in the budding growth form (Table 2). These levels were also similar to those of white budding-phase cells in the mid-log phase of growth used in the analysis of white- and opaque-phase cells (Table 1). In stationary

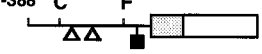
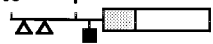
TABLE 2. Specific activity of RLUC in the bud and hypha phases of *C. albicans* strain WO-1 (Red 3/6) containing various deletions of the upstream regulatory region of *WH11* fused to *RLUC* (transcriptional fusion)<sup>a</sup>

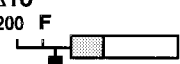
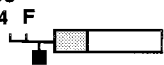
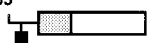
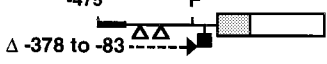
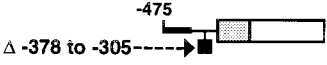
	Promoter construct	Phase	RLUC sp act (10 <sup>-2</sup> U/ $\mu$ g of protein) <sup>b</sup>	Fold increase over pCRW3	Fold difference, B/H <sup>c</sup>	Fold decrease due to deletion
1	<b>pCRW3</b> 	S	0.40 $\pm$ 0.01			
		B	0.38 $\pm$ 0.03			
		H	0.35 $\pm$ 0.07			
2	<b>pCRW5<math>\Delta</math>6</b> -475 P C F 	S	7,600 $\pm$ 390	19,000		
		B	8,000 $\pm$ 445	21,000	100	
		H	79 $\pm$ 8.4			
3	<b>pCRW5<math>\Delta</math>7</b> -388 C F 	S	910 $\pm$ 65	2,300		8
		B	850 $\pm$ 20	2,200	100	9
		H	8.4 $\pm$ 0.51			
4	<b>pCRW5<math>\Delta</math>R11</b> -305 F 	S	770 $\pm$ 43	1,900		10
		B	760 $\pm$ 43	1,900	100	11
		H	7.3 $\pm$ 0.51			
5	<b>pCRW5<math>\Delta</math>R10</b> -238 F 	S	11 $\pm$ 0.96	28		680
		B	20 $\pm$ 2.6	53	27	400
		H	0.74 $\pm$ 0.05			
6	<b>pCRW5<math>\Delta</math>10</b> -200 F 	S	0.96 $\pm$ 0.06	2		7,900
		B	0.94 $\pm$ 0.04	2		8,500
		H	0.59 $\pm$ 0.02			
7	<b>pCRW5<math>\Delta</math>39</b> -124 F 	S	0.93 $\pm$ 0.06	2		8,100
		B	1.1 $\pm$ 0.10	2		7,300
		H	1.0 $\pm$ 0.08			
8	<b>pCRW5<math>\Delta</math>Af</b> -85 	S	0.90 $\pm$ 0.01	2		8,400
		B	0.88 $\pm$ 0.03	2		9,100
		H	0.31 $\pm$ 0.01			
9	<b>pCRW5 <math>\Delta</math>6HS2</b> -475 F $\Delta$ -378 to -83 	S	6,300 $\pm$ 310	16,000		
		B	6,800 $\pm$ 311	18,000	130	
		H	52 $\pm$ 3.0			
10	<b>pCRW5 <math>\Delta</math>6HS3</b> -475 $\Delta$ -378 to -305 	S	250 $\pm$ 27	620		31
		B	230 $\pm$ 23	600	170	35
		H	1.3 $\pm$ 0.20			

<sup>a</sup> All symbols are the same as for Table 1. S, white stationary-phase cells; B, white budding cells; H, white hypha-forming cells. To induce bud or hypha formation, stationary-phase cells were diluted into fresh medium at pH 4.5 (for bud formation) or pH 6.5 (for hypha formation). Budding and hypha-forming cells were harvested 300 min after dilution. Evagination at both pHs occurred on average after 140 min.

<sup>b</sup> Specific activity is represented as the mean and standard deviation for four measurements (two measurements for each of two clones).

<sup>c</sup> The bud/hypha difference was not computed when the RLUC specific activity was twofold or less that of pCRW3.

phase, the specific activity of RLUC was approximately 19,000 times that of cells transformed with the promoterless plasmid pCRW3, and after bud formation, the specific activity was approximately 21,000 times that of cells transformed with pCRW3 (Table 2). However, after hypha formation, the specific activity of RLUC was 100-fold lower than that in the budding growth form (Table 2). Similar results were obtained with cells harboring the comparable translational fusion plasmid derivative pCWOR5 $\Delta$ 6 (data not shown).

For cells transformed with either the transcriptional fusion

derivative pCRW5 $\Delta$ 7 (Table 2) or the corresponding translational fusion derivative pCWOR5 $\Delta$ 7 (data not shown), both of which contained a deletion between -475 and -388 bp, the specific activity of RLUC in stationary-phase cells and cells after bud formation was reduced approximately ninefold compared to levels in cells transformed with either pCRW5 $\Delta$ 6 or pCWOR5 $\Delta$ 6, respectively. In both cases, these levels were still approximately 100 times greater than those in cells which had formed hyphae. Deletion of the next 83 bp, between -387 and -305 bp, in pCRW5 $\Delta$ R11, had no additional effect on RLUC

activity (Table 2). However, when the subsequent 67 bp were deleted between -305 and -239 bp, the region demonstrated to contain the proximal transcription activation sequence in the white phase, there were further decreases in specific activity of 70- and 38-fold in stationary-phase and budding cells, respectively (Table 2). The specific activity of RLUC in pCRW5ΔR10-transformed cells in stationary phase or after the formation of buds was still 15- and 27-fold, respectively, that after hypha formation (Table 2). When the subsequent 38 bp, between -238 and -201 bp, were deleted, there were additional 12- and 21-fold decreases in the specific activity of RLUC in stationary-phase and budding cells, respectively (Table 2), suggesting the presence of a minor activation sequence in the region proximal to the major proximal activation sequence, just as the deletion analysis suggested in white- and opaque-phase cells. There was an insignificant difference between hypha-forming cells and either budding or stationary-phase cells in pCRW5Δ10, and additional deletions between -200 and -83 bp had no further effect on the specific activity of RLUC (Table 2). When the proximal activation sequence was selectively eliminated by an internal deletion between -378 and -83 bp, leaving the distal activation sequence intact in pCRW5Δ6HS3, there was a 31- to 35-fold reduction in RLUC activity in stationary-phase and budding cells and a 170-fold difference between buds and hyphae (Table 2), and a similar result was obtained with the corresponding translational fusion construct, pCWOR5Δ6HS3 (data not shown). The RLUC activity in stationary and budding cells in this latter deletion derivative was still approximately 600-fold greater than that in the promoterless construct, suggesting that the distal activation sequence alone can effect the transcriptional activation of the reporter gene in a bud-specific manner.

None of the deletions analyzed resulted in an increase in RLUC activity in hypha-forming cells, demonstrating that, just as in the analysis of white- and opaque-phase cells (22), RLUC is regulated primarily by two major transcription activation sequences and a minor proximal activation sequence (Fig. 3C).

## DISCUSSION

The transcription of *WH11* in *C. albicans* strain WO-1 is regulated by two distinct developmental programs, the bud-hypha transition and high-frequency phenotypic switching, and it was our intent to investigate whether the same or different mechanisms are involved. In the original functional analysis of the *WH11* promoter in the white and opaque phases of switching, we used the semiquantitative method of Northern blot hybridization to assess the levels of gene expression under *WH11* promoter regulation (22). Here we have employed a newly developed bioluminescent reporter system which is far more sensitive than Northern blot hybridization in assessing gene expression but which depends on measurements of the luminescent activity of the gene product rather than the level of transcript (23). Using the RLUC system, we recharacterized the *WH11* promoter in the white and opaque phases and demonstrated again the presence of two major transcription activation sequences (Fig. 3A and B). However, because of the increased sensitivity of the RLUC reporter, we also demonstrated the presence of an additional, weaker activation sequence proximal to the two major sites (Fig. 3B). Both the earlier and the present analysis of the *WH11* promoter demonstrate that either of the major sequences alone will activate transcription of the *WH11* gene in a phase-specific manner, that the major proximal activation sequence is far stronger than the major distal activation sequence, and that the two sequences function synergistically, not additively, in the acti-

vation of *WH11* in the white phase. As in the previous analysis, we again found no indication of negative regulatory sequences in the *WH11* promoter functioning in the opaque phase. This leads to a very simple model in which the differential expression of *WH11* is regulated by the differential expression or activation of white-bud-phase-specific *trans*-acting factors in the white phase, and this is supported by gel retardation experiments indicating the presence of white-phase-specific, but not opaque-phase-specific, factors which bind with the major transcription activation sequences in the *WH11* promoter (25).

Using the newly developed RLUC reporter system, we next characterized the *WH11* promoter in the bud and hypha phases of dimorphism, using the same deletion derivatives employed for the characterization in the white and opaque phases. The same two major transcription activation sequences were found to be involved in the expression of *WH11* in the budding phase, and again, the same minor activation sequence proximal to the two major ones was revealed (Fig. 3C). In addition, just as in the case of the characterization of the promoter in the white and opaque phases, we found no indication of negative regulatory sequences involved in the inactivity of *WH11* in the hyphal phase. These results suggest that the same simple model for the regulation of *WH11* expression in the white and opaque phases is sufficient for the regulation of *WH11* expression in the bud and hyphal phases. Transcription activation factors are either differentially synthesized or activated in the white budding phase but not in the white hyphal phase, and the absence of *WH11* transcription in the budding phase is due solely to the absence of activators. However, this model is preliminary, since the absence of demonstrable negative regulatory sequences is not sufficient proof that such sequences do not exist and participate in facilitating the inactivity of *WH11* in either the hyphal growth form or the opaque phase. In addition, although a common model has been developed to account for the regulation of the alternate transcriptional states of *WH11* in the white and opaque phases of the switching system and the bud and hyphal phases of dimorphism, this model does not encompass the transient mechanisms which lead to the actual changes in transcriptional states during the actual phase transitions. These mechanisms may in fact differ in the two different developmental transitions, a possibility now under investigation.

In the present study, we have assayed RLUC activity, and the results obtained, therefore, may reflect the dynamics of transcription, transcript stability, protein stability, or a combinatorial effect of these three mechanisms. There are reasons to believe that RLUC levels do indeed reflect transcriptional states. While stationary-phase cells and budding cells contain the Wh11 protein, as demonstrated by indirect immunofluorescent staining with anti-Wh11 antiserum, contain *WH11* mRNA, and express *RLUC* when it is under the regulation of the *Wh11* promoter, cells which have just extended a germ tube (i.e., an incipient hypha) are devoid of Wh11 antigen, do not contain *WH11* mRNA, and contain dramatically reduced levels of RLUC activity when *RLUC* is under the regulation of the *WH11* promoter (14, 25). In addition, the relative levels of reporter transcript in the various deletion derivatives in the original promoter analysis (22) were highly similar to the relative levels of RLUC activity measured in the comparative deletion derivatives in the present study. This was true for constructs in which RLUC was synthesized in the cell as an independent protein and for those in which it was synthesized as a fusion protein with Wh11. The level of *WH11* mRNA, therefore, correlates with the level of RLUC under *WH11* promoter regulation in the different phases of the two developmental transitions in all tested deletion derivatives. Al-

though these experimental results do not provide direct measures of either protein or mRNA stability in the alternative phases of the two developmental programs, they do suggest that our interpretation of the transcriptional state of the *WH11* gene based upon RLUC activity is valid.

#### ACKNOWLEDGMENTS

This work was supported by Public Health Service grants DE10758 and AI39735.

#### REFERENCES

- Anderson, J., R. Mihalik, and D. R. Soll. 1990. Ultrastructure and antigenicity of the unique cell wall pimple of the *Candida* opaque phenotype. *J. Bacteriol.* **172**:224–235.
- Anderson, J. M., and D. R. Soll. 1987. Unique phenotype of opaque cells in the white-opaque transition of *Candida albicans*. *J. Bacteriol.* **169**:5579–5588.
- Bedell, G. W., and D. R. Soll. 1979. Effects of low concentrations of zinc on the growth and dimorphism of *Candida albicans*: evidence for zinc-resistant and zinc-sensitive pathways for mycelium formation. *Infect. Immun.* **26**:348–354.
- Bergen, M. S., E. Voss, and D. R. Soll. 1990. Switching at the cellular level in the white-opaque transition of *Candida albicans*. *J. Gen. Microbiol.* **136**:1925–1936.
- Buffo, J., M. A. Herman, and D. R. Soll. 1984. A characterization of pH-regulated dimorphism in *Candida albicans*. *Mycopathologia* **85**:21–30.
- Lorenz, W. W., R. O. McCann, M. Longiaru, and M. J. Cormier. 1991. Isolation and expression of a cDNA encoding *Renilla reniformis* luciferase. *Proc. Natl. Acad. Sci. USA* **88**:4438–4442.
- Morrow, B., T. Srikantha, J. Anderson, and D. R. Soll. 1993. Coordinate regulation of two opaque-phase-specific genes during white-opaque switching in *Candida albicans*. *Infect. Immun.* **61**:1823–1828.
- Ohama, T., T. Suzuki, M. Mori, S. Osawa, T. Ueda, K. Watanabe, and T. Nakase. 1993. Non-universal decoding of the leucine codon CUG in several *Candida* species. *Nucleic Acids Res.* **21**:4039–4045.
- Praekelt, U. M., and P. A. Meacock. 1990. *HSP12*, a new small heat shock gene of *Saccharomyces cerevisiae*: analysis of structure, regulation and function. *Mol. Gen. Genet.* **223**:97–106.
- Rikkerink, E. H., B. B. Magee, and P. T. Magee. 1988. Opaque-white phenotype transition: a programmed morphological transition in *Candida albicans*. *J. Bacteriol.* **170**:895–899.
- Sanger, F., S. Nicklen, and A. R. Coulson. 1977. DNA sequencing with chain-terminating inhibitors. *Proc. Natl. Acad. Sci. USA* **74**:5463–5467.
- Santos, M., D. R. Colthurst, N. Wills, C. S. McLaughlin, and M. F. Tuite. 1990. Efficient translation of the UAG termination codon in *Candida* species. *Curr. Genet.* **17**:487–491.
- Santos, M. A., G. Keith, and M. F. Tuite. 1993. Non-standard translational events in *Candida albicans* mediated by an unusual seryl-tRNA with a 5'-CAG-3' (leucine) anticodon. *EMBO J.* **12**:607–616.
- Schröppel, K., T. Srikantha, D. Wessels, M. DeCock, S. R. Lockhart, and D. R. Soll. 1996. Cytoplasmic localization of the white phase-specific *WH11* gene product of *Candida albicans*. *Microbiology* **142**:2245–2254.
- Slutsky, B., M. Staebell, J. Anderson, L. Risen, M. Pfaller, and D. R. Soll. 1987. "White-opaque transition": a second high-frequency switching system in *Candida albicans*. *J. Bacteriol.* **169**:189–197.
- Soll, D. R. 1986. The regulation of cellular differentiation in the dimorphic yeast *Candida albicans*. *Bioessays* **5**:5–11.
- Soll, D. R. 1992. High-frequency switching in *Candida albicans*. *Clin. Microbiol. Rev.* **5**:183–203.
- Soll, D. R. 1996. The emerging molecular biology of switching in *Candida albicans*. *ASM News* **62**:415–420.
- Soll, D. R. 1997. Gene regulation during high-frequency switching in *Candida albicans*. *Microbiology* **143**:279–288.
- Soll, D. R., J. Anderson, and M. Bergen. 1991. The developmental biology of the white-opaque transition in *Candida albicans*, p. 20–45. *In* R. Prasad (ed.), *Candida albicans: cellular and molecular biology*. Springer Verlag, Berlin, Germany.
- Soll, D. R., T. Srikantha, B. Morrow, A. Chandrasekhar, K. Schröppel, and S. Lockhart. 1995. Gene regulation in the white-opaque transition of *Candida albicans*. *Can. J. Bot.* **73**(Suppl.):1049–1057.
- Srikantha, T., A. Chandrasekhar, and D. R. Soll. 1995. Functional analysis of the promoter of the phase-specific *WH11* gene of *Candida albicans*. *Mol. Cell. Biol.* **15**:1797–1805.
- Srikantha, T., A. Klapach, W. W. Lorenz, L. K. Tsai, L. A. Laughlin, J. A. Gorman, and D. R. Soll. 1996. The sea pansy *Renilla reniformis* luciferase serves as a sensitive bioluminescent reporter for differential gene expression in *Candida albicans*. *J. Bacteriol.* **178**:121–129.
- Srikantha, T., B. Morrow, K. Schröppel, and D. R. Soll. 1995. The frequency of integrative transformation at phase-specific genes of *Candida albicans* correlates with their transcriptional state. *Mol. Gen. Genet.* **246**:342–352.
- Srikantha, T., and D. R. Soll. 1993. A white-specific gene in the white-opaque switching system of *Candida albicans*. *Gene* **131**:53–60.
- Stone, R. L., V. Matarese, B. B. Magee, P. T. Magee, and D. A. Bernlohr. 1990. Cloning, sequencing and chromosomal assignment of a gene from *Saccharomyces cerevisiae* which is negatively regulated by glucose and positively by lipids. *Gene* **96**:171–176.