

# Linkage of Early-Onset Osteoarthritis and Chondrocalcinosis to Human Chromosome 8q

Clinton T. Baldwin,<sup>1,2</sup> Lindsay A. Farrer,<sup>3,4</sup> Ronald Adair,<sup>1</sup> Rita Dharmavaram,<sup>5</sup> Sergio Jimenez,<sup>5</sup> and Larry Anderson<sup>6</sup>

<sup>1</sup>Center for Human Genetics and Departments of <sup>2</sup>Pediatrics, <sup>3</sup>Neurology, and <sup>4</sup>Epidemiology and Biostatistics, Boston University School of Medicine, Boston; <sup>5</sup>Department of Medicine, Thomas Jefferson University, Philadelphia; and <sup>6</sup>Rheumatology Associates, Portland, ME

## Summary

Calcium pyrophosphate–deposition disease (CPDD), also called “chondrocalcinosis” or “pseudogout,” is a disorder characterized by the deposition of calcium-containing crystals in joint tissue, which leads to arthritis-like symptoms. The presence of these crystals in joint tissue is a common finding in the elderly, and, in this population, there is a poor correlation with joint pain. In contrast, early-onset CPDD has been described in several large families in which the disease progresses to severe degenerative osteoarthritis (OA). In these families, an autosomal dominant mode of inheritance is observed, with an age at onset between the 2d and 5th decades of life. In this report, we describe a large New England family with early-onset CPDD and severe degenerative OA. We found genetic linkage between the disease in this family and chromosome 8q, with a multipoint lod score of 4.06. These results suggest that a defective gene at this location causes the disease in this family.

## Introduction

Calcium pyrophosphate–deposition disease (CPDD), also referred to as “chondrocalcinosis” or “pseudogout,” is characterized by the deposition of crystalline forms of calcium—the two most common forms being calcium pyrophosphate dihydrate and basic calcium phosphate—in the synovial fluid, cartilage, and periarticular soft tissue (Fam 1992; Ryan 1993). Several large families with familial forms of early-onset CPDD have been described elsewhere (Richardson et al. 1983; Balsa et al. 1990; Eshel et al. 1990; Doherty et al. 1991; Hamza et al. 1992). In these families, an autosomal dominant mode of inheritance, with an age at onset between the 2d and 5th decades of life, has been

proposed. In affected members of these families, acute inflammatory arthritis is triggered by trauma, exercise, or changes in the weather. Attacks are self-limited and progress, with time, to chronic arthropathy and degenerative joint disease.

We describe here a six-generation family with an autosomal dominant form of osteoarthritis (OA) in which many of the affected individuals have CPDD. After conducting a genome-wide search with highly polymorphic chromosomal markers, we found linkage of the disease to human chromosome 8q, with a lod score of 4.06. These results suggest that a single defect is responsible for the disease in this family.

## Methods

### Typing Microsatellite Markers

Peripheral blood was obtained from the subjects, in accordance with institutional guidelines for human subjects. To isolate DNA, erythrocytes were lysed in buffer containing 0.32 M sucrose, 1% triton X-100, 5 mM MgCl<sub>2</sub>, and 10 mM Tris, pH 7.6, and were centrifuged at low speed. The leukocytes were resuspended in 75 mM NaCl, 24 mM EDTA, pH 8.0, and were adjusted to 0.5% SDS. Proteinase K (150 µg/ml) was added, and the samples were digested 4–8 h at 42°C. DNA was extracted with phenol (2–4 h), followed by extraction with chloroform. A 1/10 vol of 3 M sodium acetate and 1 vol of isopropanol were added, to precipitate the DNA. The precipitate was removed, air-dried, and redissolved in 10 mM Tris-HCl, 1 mM EDTA, pH 7.6.

Oligonucleotides for typing microsatellite markers were synthesized on a Milligen 7500 DNA synthesizer. A standard amplification reaction (Saiki et al. 1988) (10 µl) was performed with 40 ng of genomic DNA and 1.0 pmol of each primer. Cycling parameters consisted of 95°C for 5 min, followed by 35 cycles of 94°C for 1 min, 60°C for 30 s, and 72°C for 30 s. Prior to amplification, one primer was end-labeled with <sup>32</sup>P polynucleotide kinase (New England Biolabs), in order that the amplification product could be visualized by autoradiography after application to a standard sequencing gel.

Received September 23, 1994; accepted for publication December 9, 1994.

Address for correspondence and reprints: Dr. Clinton T. Baldwin, Center for Human Genetics, Boston University School of Medicine, 80 East Concord Street, Boston, MA 02118.

© 1995 by The American Society of Human Genetics. All rights reserved.  
0002-9297/95/5603-0019\$02.00

### Statistical Analysis

Linkage of OA/CPDD to genetic markers was assessed by using the computer programs LIPED and LINKAGE (version 4.9). The disease locus was modeled as an autosomal dominant trait with complete penetrance (clinically or on x-ray examination) by age 25 years. All individuals included in this study were  $\geq 25$  years old, and all underwent physical examination (except for 3106, who was therefore considered with an unknown OA/CPDD phenotype). We detected no unaffected carriers of the mutant allele, so allowance for reduced penetrance was deemed unnecessary. Computation of lod scores in this complex pedigree was facilitated by reducing the number of alleles for each marker system to no more than four by using the scheme of Braverman (1985).

Initially, the disease allele frequency was assumed to be relatively rare (.0005), since there are few published reports of dominantly transmitted OA with severe and early onset of symptoms. Because all affected individuals in this kindred, except for six gene carriers in the upper generations, were studied, one would not expect that these analyses would be sensitive to assumptions concerning frequencies of the disease or marker alleles. However, pairwise analyses were repeated by using (i) marker allele frequencies estimated from 12 chromosomes of unaffected spouses, (ii) equal allele frequencies, and (iii) a much higher allele frequency of .10 for the disease allele. Conclusions about linkage or the maximum-likelihood estimates of recombination were unchanged (results not shown).

Support for linkage in various intervals of the linkage map for chromosome 8q was evaluated by multilocus linkage analysis. A series of overlapping four-locus analyses were carried out in a manner that allows comparison of results across all intervals and efficient computation (Bowcock et al. 1987). A sex-averaged genetic linkage map was deduced from two sources and is as follows: D8S525–(11 cM)–D8S257–(4 cM)–D8S521–(1 cM)–D8S545–(1 cM)–D8S556–(6 cM)–(D8S539–[0 cM]–D8S555–[0 cM]–D8S565–[2 cM])–CH736–(1 cM)–CH945–(3 cM)–D8S269–(14 cM)–D8S284–(8 cM)–D8S537–(3 cM)–D8S554 (Gyapay et al. 1994; Murray et al. 1994).

## Results

### Clinical Evaluation of Family BU91

Affected and unaffected members of the family were evaluated for the presence or absence of CPDD/OA by x-ray examination and/or physical examination (fig. 1). For individuals  $>40$  years of age, diagnosis of the disease required radiological evidence of joint-space narrowing due to degenerative osteoarthritis and/or the presence of calcium-containing crystals in joints. Diagnosis of younger members of the family ( $<40$  years of age) was based on the occurrence of acute attacks of OA/CPDD with significant joint pain.

### Clinical Features of the Oldest Generation

Individual 9001 (no sample) had long-standing destructive arthritis involving ankles, knees, hands, and wrists, with onset in his early 40s. He had marked kyphosis and severe valgus deformity of his knees and showed severe CPDD in both knees and wrists and calcification of synovial membranes of the metatarsal joints. Ankle joints showed complete joint-space loss. He reported that his brother (no sample) also had severe arthritis at an early age and required total knee replacement.

### Clinical Features of the Third Generation

Individual 3115 had knee arthritis since his 30s and by age 41 years developed joint-space narrowing, subchondral sclerosis, and severe flexion contractures of both knees and CPDD on the posterior surface of the patella. Similar signs were observed in other joints, but with less destructive changes, and he has undergone total knee replacement. His brother (3122) developed progressive destructive OA involving knees and right ankle in his early 40s. X-rays showed CPDD in his left knee, and synovial fluid analysis confirmed calcium pyrophosphate crystals. He has complete narrowing of the medial joint space of his left knee and complete loss of cartilaginous surfaces of the talotibial joint in his right ankle.

Individual 3110 developed hip and elbow arthritis in her late 30s. In her 40s, degenerative changes in both knees were noted, and the presence of calcium pyrophosphate crystals was observed in both knees. Her sister (3125) had joint pain that began in her 40s and had her first attack of CPDD at age 54 years. At that time, severe OA was noted, and the presence of CPDD was noted in both knees and one ankle. Her entire right knee was replaced at age 57 years. Their brother (9002; no sample) had polyarticular rheumatoid arthritis. X-rays of his knees, at age 60 years, showed degenerative disease with CPDD. He had progressive rheumatoid arthritis and OA and died of an unrelated cause. It was not possible to diagnose individual 3106 accurately, because of an injury sustained from a sports accident. Thus, his diagnosis in the linkage analysis was considered ambiguous.

### Clinical Features of the Younger Generation

Individual 3126 was first seen at age 39 years. She had experienced bilateral knee discomfort since age 23 years, with no history of trauma. X-rays of her knee showed advanced loss of joint space within the medial compartments, without CPDD. Her brother (3111) had experienced discomfort in his left knee since his mid 20s, with no history of knee trauma. X-ray demonstrated moderate narrowing of joint spaces in both medial compartments and early hypertrophic degenerative changes. The youngest affected members of this family (3117 and 3119), at ages 25 and 27 years, have phenotypes consistent with the early

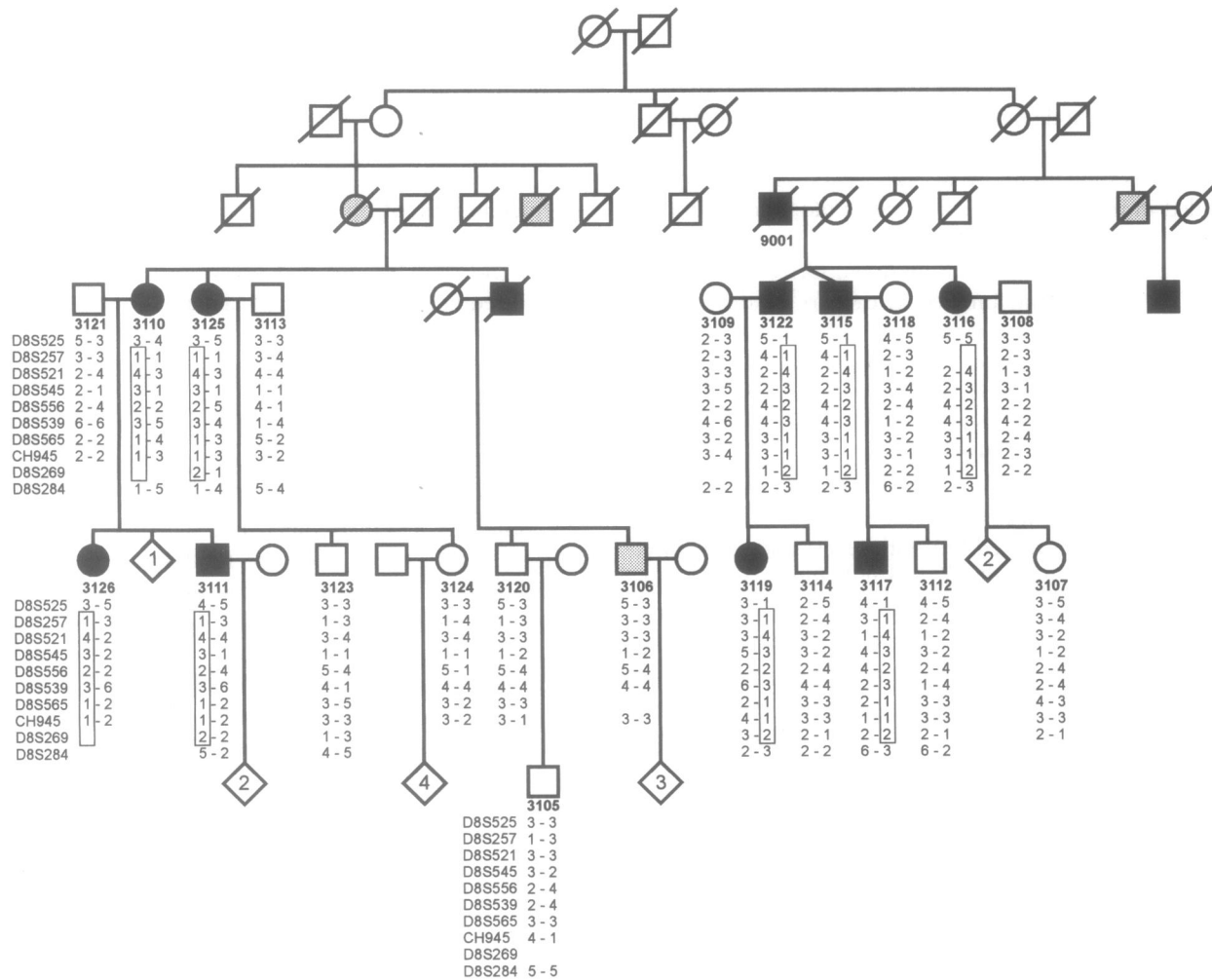

**Figure 1** Pedigree of family BU91. Dark-shaded symbols represent individuals with a clear diagnosis of OA/CPDD. Gray-shaded symbols represent individuals who could not be clearly diagnosed with the disease. Below each symbol are the identifier for each person and the results of the microsatellite marker typing. The alleles enclosed in boxes represent haplotypes associated with the disease in the family.

stages of the disease, which consist of swelling of both knees following exercise and hip, neck, and knee pain.

**Genotype Studies**

The pattern of the disease in this family suggested an autosomal dominant mode of inheritance, with age at onset between ages 25 and 40 years. Male and female members of the family are equally affected, and no evidence for anticipation is present. Peripheral blood was obtained from family members, in accordance with institutional guidelines for human research, and DNA was extracted from the peripheral blood leukocytes by Proteinase K-SDS.

A genome-wide search, with an array of highly polymorphic microsatellite loci, was used to identify a chromosomal location of the OA/CPDD gene. An array of tetranucleotide-repeat polymorphisms developed by the Cooperative Human Linkage Center (Murray et al. 1994) were used

because allele scoring for these markers is much easier than for dinucleotide-repeat polymorphisms.

To make our search more efficient, we selected a subset of the family members (3109, 3122, 3115, 3118, 3119, 3114, 3117, 3112, 3121, 3110, 3126, and 3111). These individuals represent nuclear families on both sides of the pedigree and are related through the first generation. Moreover, these individuals are the most elderly members of the family, and, among them, expression of the OA/CPDD phenotype is clearly evident. After testing this subset of the family with 150 markers, we found 145 were not linked and 3 were consistent with linkage. The entire family was then tested with these three markers, and only one marker (D8S565) was found to segregate with the disease.

**Linkage of the Disease to Human Chromosome 8**

The segregation from chromosome 8q of several anonymous microsatellite markers flanking D8S565 was tested

**Table 1****Results of Pairwise Linkage Analysis between OA/CPDD and Chromosome 8 Markers**

Marker	Z at $\theta =$								$\hat{Z}$	$\hat{\theta}$
	0	.01	.05	.1	.2	.3	.4			
D8S525 .....	$-\infty$	-2.94	-1.01	-.32	.12	.17	.07	.19	.19	.28
D8S257 .....	1.26	1.27	1.24	1.15	.86	.53	.20	1.27	1.27	.02
D8S521 .....	3.26	3.19	2.99	2.55	1.83	1.09	.39	3.26	3.26	0
D8S545 .....	3.21	3.14	2.86	2.51	1.79	1.06	.38	3.21	3.21	0
D8S556 .....	1.97	1.91	1.71	1.45	.95	.49	.15	1.97	1.97	0
D8S539 .....	2.97	2.90	2.64	2.30	1.62	.94	.31	2.97	2.97	0
D8S555 .....	2.32	2.26	2.03	1.75	1.19	1.66	1.21	2.32	2.32	0
D8S565 .....	3.43	3.36	3.07	2.70	1.94	1.17	.43	3.43	3.43	0
CH736 .....	1.16	1.13	1.00	0.84	.52	.26	.08	1.16	1.16	0
CH945 .....	2.64	2.60	2.40	2.12	1.52	.89	.30	2.64	2.64	0
D8S269 .....	2.10	2.05	1.84	1.58	1.06	1.58	.18	2.10	2.10	0
D8S284 .....	-1.71	.16	.70	.81	.74	.55	.30	.81	.81	.09
D8S537 .....	-1.60	.29	.80	.86	.67	.37	.10	.86	.86	.09
D8S554 .....	$-\infty$	-1.07	-.44	-.22	-.06	-.02	-.01	0	0	.5

for linkage to OA/CPDD. Two markers (D8S565 and D8S521) provided significant lod scores ( $Z > 3.0$ ) without observed recombination events (table 1). These observations were robust ( $Z > 3.0$ ) over a range of assumptions concerning the disease and marker allele frequencies, which suggests that the OA/CPDD gene in this pedigree maps to human chromosome 8q. Several other markers (table 1) also showed no evidence of recombination (i.e.,  $\theta = 0$ ), but they were less informative in this family. Recombination was observed between OA/CPDD and markers at both ends of the linkage group, namely, D8S525, D8S284, D8S537, and D8S554.

**Multilocus Analysis**

To define the location of OA/CPDD more precisely, we undertook a multilocus analysis using the markers D8S525, D8S527, D8S521, D8S565, CH945, D8S269, and D8S284. This set of markers was chosen because, collectively, they capture all of the meiotic information for this region of chromosome 8q. This analysis clearly showed that OA/CPDD is most likely located between D8S525 and D8S284 (fig. 2). The candidate region, as defined by a one-lod-unit confidence interval (Conneally et al. 1985), includes all locations  $>7$  cM distal to D8S525 and  $<10$  cM proximal to D8S284. Direct inspection of the haplotype data (fig. 1) confirms these statistical analyses and localizes the OA/CPDD defect to a 32-cM region between D8S525 and D8S284, on chromosome 8q.

**Discussion**

We present evidence in this report for genetic linkage between markers on human chromosome 8q and the disease, in a large pedigree with early-onset OA and CPDD.

This is the first identification of a chromosomal location for a OA/CPDD gene and one of the few that cause a form of OA. This represents the first step in understanding what is the primary cause of OA/CPDD.

The pattern of disease aggregation in the family described here is similar to that in others with early-onset OA/CPDD that have been previously reported, which suggests a strong genetic component in disease etiology (Richardson et al. 1983; Balsa et al. 1990; Eshel et al. 1990; Doherty et al. 1991; Hamza et al. 1992). In our family, it is unclear whether the primary event causing the disease is deposition

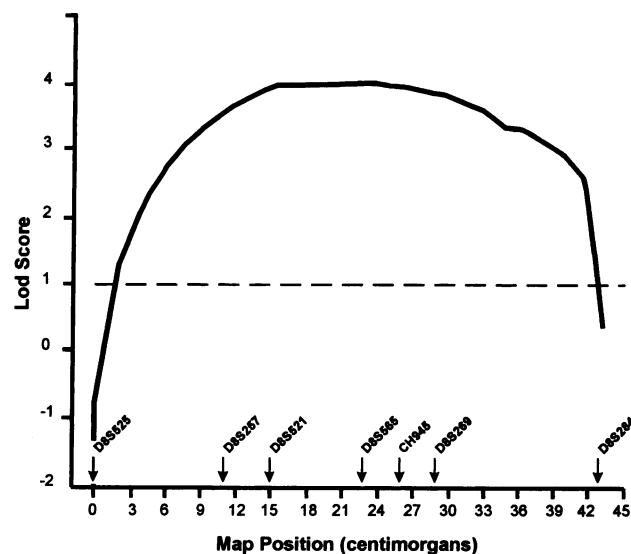

**Figure 2** Support for position of OA/CPDD gene, with respect to chromosome 8 marker loci. The position of D8S525 was arbitrarily set at 0.0, and the positions of other loci were fixed according to the genetic map for this region (see Methods).

of calcium-containing crystals in joint tissue (caused by a defect in a CPDD gene) that progresses to severe degenerative OA or whether degenerative changes in cartilage (resulting from mutation in an OA gene) enhance deposition of calcium-containing crystals.

Several epidemiological surveys have established the frequency of CPDD in the general population at 5% to 10% (Felson et al. 1989; Ledingham et al. 1992; Patrick et al. 1993; Sanmarti et al. 1993). The results suggested that CPDD was more prevalent in women (14%) than in men (6%). The incidence of CPDD increases dramatically with age: ~7% of the subjects between 60 and 69 years of age are affected, while in subjects >80 years old, the frequency of the disease is ~43%. However, many subjects in these studies are unaware of CPDD and have mild or absent clinical manifestations. These results would suggest that the presence of calcium crystals in articular joints may have little clinical significance and that their presence may be a secondary effect of the disease in family BU91. Ultimately, this question can be resolved only by understanding what is the primary defect that causes the disease.

Our report, describing the first evidence for a strong genetic component to early-onset CPDD, supports the hypothesis that defects in genes expressed in cartilage play a major role in the etiology of OA. In addition to the chromosome 8 loci described here, genetic defects have been described in several families with early-onset OA due to rare congenital malformation. This includes families with chondrodysplasia (Lee et al. 1989; Ala-Kokko et al. 1990; Tiller et al. 1990; Williams et al. 1993; Pun et al. 1994), hypochondrogenesis (Bogaert et al. 1992), Stickler syndrome (Ahmad et al. 1991), and short-limbed dwarfism (Vissing et al. 1989). In each of these disorders, the genetic defect has been found in the type II procollagen gene (COL2A1), the gene encoding the major structural protein found in cartilage. Defects in type X collagen (COL10A1), a minor collagen type present in cartilage, have also been described in other families with heritable forms of chondrodysplasia (Warman et al. 1993). In addition, linkage to an undefined gene on chromosome 19 has been reported in a family with multiple epiphyseal dysplasia (Oellmann et al. 1994).

While CPDD is associated with severe degenerative OA in some families, the presence of calcium pyrophosphate crystals may also play a role in inflammatory forms of arthritis. Calcium pyrophosphate-containing crystals are potent activators of leukocytes, and the presence of crystals would be expected to induce collagenase production, as well as chemoattractants, for other leukocytes (Fam 1992; Naccache et al. 1993). In the family we studied here, we found one individual with a similar phenotype.

OA and other musculoskeletal disorders represent a leading cause of morbidity in the population, as well as a major cause of chronic health problems, long-term disability, consultation with health professionals, and use of prescription

and nonprescription drugs (Badley et al. 1994). Thus, identification of the gene defect in family BU91 with an inherited form of OA/CPDD and the understanding of its gene product will contribute significantly to the understanding of the molecular events that are important to cartilage function. It will also provide new methods to diagnose those individuals predisposed to osteoarthritis and will provide the basis for developing new models for the disease, in which new therapies can be tested.

## Acknowledgments

Supported by grant AR40152, to C.T.B., from the National Institutes of Health.

## References

- Ahmad NN, Ala-Kokko L, Knowlton RG, Jimenez SA, Weaver EJ, Maguire JL, Tasman W, et al (1991) Stop codon in the procollagen II gene (Col2A1) in a family with the Stickler syndrome (arthro-ophthalmopathy). *Proc Natl Acad Sci USA* 88:6624-6627
- Ala-Kokko L, Baldwin CT, Moskowitz RW, Prockop DJ (1990) Single base mutation in the type II procollagen gene (Col2A1) as a cause of primary OA associated with a mild chondrodysplasia. *Proc Natl Acad Sci USA* 87:6565-6558
- Badley E, Rasooly I, Webster G (1994) Relative importance of musculoskeletal disorders as a cause of chronic health problems, disability, and health care utilization: findings from the 1990 Ontario health survey. *J Rheumatol* 21:505-514
- Balsa A, Martin-Mola E, Gonzalez T, Cruz A, Ojeda S, Gijon-Banos J (1990) Familial articular chondrocalcinosis in Spain. *Ann Rheum Dis* 49:531-535
- Bogaert R, Tiller G, Weis M, Gruber H, Rimoin D, Cohn D, Eyre E (1992) An amino acid substitution (Gly-853-Glu) in the collagen  $\alpha 1(\text{II})$  chain produces hypochondrogenesis. *J Biol Chem* 267:22522-22526
- Bowcock AM, Farrer LA, Cavalli-Sforza LL, Hebert JM, Kidd KK, Frydman M, Bonne-Tamir B (1987) Mapping the Wilson disease locus to a cluster of linked polymorphic markers on chromosome 13. *Am J Hum Genet* 41:27-35
- Braverman MS (1985) An algorithm to improve the computational efficiency of genetic linkage analysis. *Comput Biomed Res* 18:24-36
- Conneally PM, Edwards JH, Kidd KK, Lalouel JM, Morton NE, Ott J, White R (1985) Report of the Committee on Methods of Linkage Analysis and Reporting. *Cytogenet Cell Genet* 40:356-359
- Doherty M, Hamilton E, Henderson J, Misra H, Dixey J (1991) Familial chondrocalcinosis due to calcium pyrophosphate dihydrate crystal deposition in English families. *Br J Rheum* 30:10-15
- Eshel G, Gulik A, Halperin N, Avrahami E, Schumacher H, McCary D, Caspi D (1990) Hereditary chondrocalcinosis in an Ashkenazi Jewish family. *Ann Rheum Dis* 49:528-530
- Fam AG (1992) Calcium pyrophosphate crystal deposition disease and other crystal deposition diseases. *Curr Opin Rheum* 4:574-582

- Felson D, Andersson J, Naimark A, Kannel W, Meenan R (1989) The prevalence of chondrocalcinosis in the elderly and its association with knee osteoarthritis: the Framingham study. *J Rheumatol* 16:1241–1245
- Gyapay G, Morissette J, Vignal A, Dib C, Fizames C, Millasseau P, Marc S, et al (1994) The 1993–94 Généthon human genetic linkage map. *Nat Genet* 7:246–339
- Hamza M, Meddeb N, Bardin T (1992) Hereditary chondrocalcinosis in a Tunisian family. *Clin Exp Rheum* 10:43–49
- Ledingham J, Dawson S, Preston B, Milligan G, Doherty M (1992) Radiographic patterns and associations of osteoarthritis of the hip. *Ann Rheum Dis* 51:1111–1116
- Lee B, Vissing H, Ramirez F, Rogers D, Rimoin D (1989) Identification of the molecular defect in a family with spondyloepiphyseal dysplasia. *Science* 244:978–980
- Murray JC, Buetow KH, Weber JL, Ludwigsen S, Sherpier-Heddema T, Manion F, Quillen J, et al (1994) A comprehensive human linkage map with centimorgan density. *Science* 265:2049–2054
- Naccache P, Bourgoïn S, Plante E, Roberge C, deMedicus R, Lussier A, Poubelle P (1993) Crystal-induced neutrophil activation. *Arthritis Rheum* 36:117–121
- Oehlmann R, Summerville GP, Yeh G, Weaver EJ, Jimenez SA, Knowlton RG (1994) Genetic linkage mapping of multiple epiphyseal dysplasia to the pericentromeric region of chromosome 19. *Am J Hum Genet* 54:3–10
- Patrick M, Hamilton E, Wilson R, Austin R, Austin S, Doherty M (1993) Association of radiographic changes of OA, symptoms, and synovial fluid particles in 300 knees. *Ann Rheum Dis* 52:97–103
- Pun Y, Moskowitz R, Lie S, Sundstrom W, Block S, McEwen C, Williams H, et al (1994) Clinical correlations of osteoarthritis with single base mutation (arginine 519-cysteine) in type II procollagen gene: a newly defined pathogenesis. *Arthritis Rheum* 37:264–269
- Richardson B, Chafetz N, Ferrell L, Zulman J, Genant H (1983) Hereditary chondrocalcinosis in a Mexican-American family. *Arthritis Rheum* 26:1387–1396
- Ryan LM (1993) Calcium pyrophosphate dihydrate crystal deposition and other crystal deposition diseases. *Curr Opin Rheum* 5:517–521
- Saiki R, Gelfand DH, Stoffel SJ, Hiquchi R, Horn G, Mullis K, Erlich H (1988) Primer-directed enzymatic amplification of DNA with thermostable DNA polymerase. *Science* 239:487–491
- Sanmarti R, Panella D, Brancos M, Canela J, Collado A, Bragues J (1993) Prevalence of articular chondrocalcinosis in elderly subjects in a rural area of Catalonia. *Ann Rheum Dis* 52:418–422
- Tiller GE, Rimoin DL, Murray LW, Cohn DH (1990) Tandem duplication within a type II collagen gene (Col2A1) exon in an individual with spondyloepiphyseal dysplasia. *Proc Natl Acad Sci USA* 87:3889–3893
- Vissing H, D'Alessio M, Lee B, Ramirez F, Godfrey M, Hollister DW (1989) Glycine to serine substitution in the triple helical domain of pro- $\alpha$ 1(II) collagen results in a lethal perinatal form of short-limbed dwarfism. *J Biol Chem* 264:18265–18267
- Warman ML, Abbott M, Apte SS, Hefferon T, McIntosh I, Cohn DH, Hecht JT, et al (1993) A type X collagen mutation causes Schmid metaphyseal chondrodysplasia. *Nat Genet* 5:79–82
- Williams C, Considine E, Knowlton R, Reginato A, Neumann G, Harrison D, Buxton P, et al (1993) Spondyloepiphyseal dysplasia and precocious OA in a family with Arg75-Cys mutation in the procollagen type II gene (COL2A1). *Hum Genet* 92:499–505