

## Release of Flagellar Filament-Hook-Rod Complex by a *Salmonella typhimurium* Mutant Defective in the M Ring of the Basal Body

H. OKINO,<sup>1</sup> M. ISOMURA,<sup>2</sup> S. YAMAGUCHI,<sup>2</sup> Y. MAGARIYAMA,<sup>1</sup> S. KUDO,<sup>1</sup> AND S.-I. AIZAWA<sup>1\*</sup>

*ERATO, Research and Development Corporation of Japan, 5-9-5 Tokodai, Tsukuba, Ibaraki 300-26,<sup>1</sup> and Department of Biology, School of Education, Waseda University, Nishi-Waseda, Tokyo,<sup>2</sup> Japan*

Received 12 September 1988/Accepted 15 December 1988

**A *Salmonella typhimurium* strain possessing a mutation in the *fliF* gene (coding for the component protein of the M ring of the flagellar basal body) swarmed poorly on a semisolid plate. However, cells grown in liquid medium swam normally and did not show any differences from wild-type cells in terms of swimming speed or tumbling frequency. When mutant cells were grown in a viscous medium, detached bundles of flagellar filaments as long as 100  $\mu\text{m}$  were formed and the cells had impaired motility. Electron microscopy and immunoelectron microscopy revealed that the filaments released from the cells had the hook and a part of the rod of the flagellar basal body still attached. Sodium dodecyl sulfate-polyacrylamide gel electrophoresis and two-dimensional gel electrophoresis showed that the rod portion of the released structures consisted of the 30-kilodalton FlgG protein. Double mutants containing this *fliF* mutation and various *che* mutations were constructed, and their behavior in viscous media was analyzed. When the flagellar rotation of the mutants was strongly biased to either a counterclockwise or a clockwise direction, detached bundles were not formed. The formation of large bundles was most extreme in mutants weakly biased to clockwise rotation.**

The flagellar motor of bacteria is a rotary engine which generates the torque to rotate the flagellar filament (16). The basal body of the flagellum was isolated from the cell by DePamphilis and Adler in 1971 (4-6). Subsequently, identification of the genes coding for the components of the basal body revealed that the basal body did not contain any of the five *mot* and *fla* gene products (MotA, MotB, FliG, FliM and FliN in *Salmonella typhimurium*) which were necessary for the motor function (1). Yamaguchi et al. suggested that a switch complex composed of FliG, FliM, and FliN played an important role in energy transduction as well as in chemotactic signal transduction (21, 22). (Note that the flagellar gene symbols follow the new nomenclature described in reference 10.)

Nevertheless, the basal body is obviously a major part of the motor. The flagellar filament is connected to the rod through the hook, which presumably works as a universal joint (3). The outer two rings are thought to act as a bushing for the rod as it passes through the peptidoglycan layer and the outer membrane (2). According to the schematic model of the basal body presented by DePamphilis and Adler (5), the rod is a simple cylindrical structure. However, biochemical analysis of the basal body suggested that the rod might consist of two proteins (1). Furthermore, doubt about the homogeneity of the rod structure has been raised by electron microscopy of the basal body, where the outer rings are observed at an essentially constant position along the rod (M. J. B. Stallmeyer, S.-I. Aizawa, R. M. Macnab, and D. J. DeRosier, *J. Mol. Biol.*, in press).

The M ring of the basal body is the cell-proximal terminus of the flagellum as detected by electron microscopy. Just above the M ring lies the S ring. The major component of the M ring is a 65-kilodalton (kDa) protein which is encoded by the *fliF* gene (7).

We isolated a mutant, SJW3060, defective in the *fliF* gene. SJW3060 cells had intact flagella and swam normally in liquid. However, the mutant could be distinguished from the

wild type on a semisolid plate, since it swarmed poorly. Observation by dark-field microscopy revealed that the mutant released flagellar filaments under certain conditions. The released filaments retained the hook and a part of the rod of the basal body. We therefore term them filament-hook-rod (FHR) complexes. The relationship between the fragility of the rod structure and an altered state of the M ring is discussed.

### MATERIALS AND METHODS

**Strains.** SJW3060 is a spontaneous mutant of SJW1103 (a wild-type strain of *S. typhimurium*). Various switching mutants used in this study were also derived from SJW1103, as listed in Table 1. Double mutants which have the original SJW3060 mutation plus various mutations conferring abnormal switching probability were constructed by P22 transduction, as described below.

**Chemicals.** Agar powder was obtained from Shouei Agar Co., Inc., and gelatin powder was from Nitta Gelatin, Ltd. Yeast extract was obtained from Oxoid Ltd., and tryptone was from Difco Laboratories.

Ampholines were obtained from LKB Instruments, Inc. All other chemicals used for the electrophoresis were obtained from Wako Pure Chemical Industries, Ltd.

**Solutions and media.** Phosphate-buffered saline contained 0.15 M NaCl and 13 mM phosphate buffer, pH 7.0. L broth contained 0.5% yeast extract, 1% tryptone, and 0.5% NaCl, pH 7.2. Semisolid plates contained 0.3% agar and 8% gelatin in L broth.

**Electrophoresis.** Sodium dodecyl sulfate (SDS)-polyacrylamide gel electrophoresis was performed by the method of Laemmli (13) at a polyacrylamide concentration of 12.5%. Two-dimensional electrophoresis was performed by the method of O'Farrell (19) with several minor modifications as described previously (1).

Gels were stained either with Coomassie brilliant blue R or with silver. Silver staining was carried out as described previously (1).

**High-intensity dark-field light microscopy.** Flagellar prepa-

\* Corresponding author.

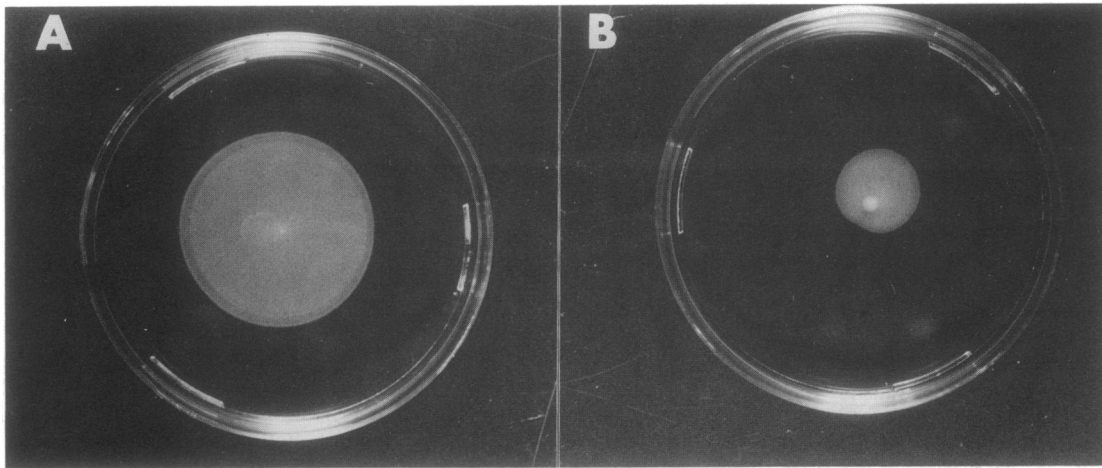

FIG. 1. Colony morphology of SJW3060 on a semisolid plate. Cells were inoculated at the center of semisolid plates and incubated at 37°C overnight. The wild-type strain SJW1103 (A) swarms much more rapidly than the mutant SJW3060 (B). The diameter of the plate is 9 cm.

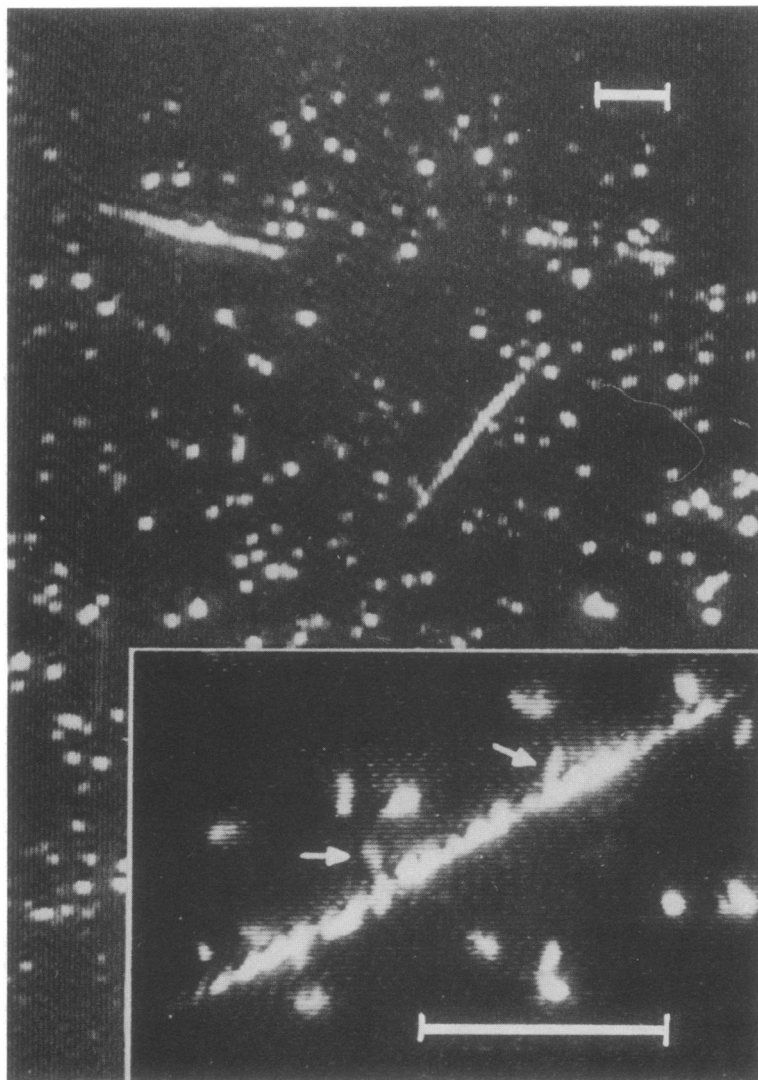

FIG. 2. Large bundles in a viscous medium. The SJW3060 cells were grown overnight in L broth containing 4% gelatin. The cell suspension was observed by dark-field microscopy and recorded by video camera. Bundles released into the viscous medium are much bigger than the cell bodies (dots in the background). Several cells are still attached to a large bundle (arrows, inset). Bars, 20  $\mu\text{m}$ .

TABLE 1. *S. typhimurium* strains used in this study

Strain	Relevant genotype <sup>a</sup>	Donor	Recipient	Reference or source
SJW1103	Wild type			S. Yamaguchi (23)
SJW1556	$\Delta(fliJ-fliN)$			S. Yamaguchi (22)
SJW1630	$\Delta(flhA-flhD)$			This study
SJW3060	<i>fliF</i>			This study
SJW3086	<i>fliF</i>	SJW1556	SJW3060	This study
	$\Delta(fliJ-fliN)$			
SJW3087	<i>fliF</i>	SJW1630	SJW3060	This study
	$\Delta(flhA-flhD)$			
SJW2903	<i>cheY</i>			This study
SJW3039	<i>cheZ</i>			This study
SJW3092	<i>cheZ</i>			This study
SJW2298	<i>fliM</i>			This study
SJW3094	<i>fliF cheY</i>	SJW2903	SJW3087	This study
SJW3091	<i>fliF cheZ</i>	SJW3039	SJW3087	This study
SJW3093	<i>fliF cheZ</i>	SJW3039	SJW3087	This study
SJW3096	<i>fliF fliM</i>	SJW2298	SJW3086	This study

<sup>a</sup> Here and throughout this paper, flagellar gene symbols follow the new unified nomenclature for *S. typhimurium* and *Escherichia coli* (10).

rations were observed by high-intensity dark-field light microscopy as described before (9, 14).

**Electron microscopy.** Samples of released FHR complexes were examined with a JEM-100S electron microscope, with 2% phosphotungstate as a negative stain. Immunoelectron microscopy was performed as described previously (7).

**Purification of FHR complexes released by SJW3060.** The SJW3060 cells were spread on semisolid plates and incubated at 37°C overnight. The agar and gelatin layer was just thick enough to cover the surface of the plates. The semisolid layers collected from 20 plates were centrifuged at  $5,000 \times g$  for 15 min. The pellets were dissolved in distilled water, and the suspension was centrifuged at  $10,000 \times g$  for 30 min to sediment the gelatin. The FHR complexes in the supernatant were sedimented at  $100,000 \times g$  for 1 h, suspended in phosphate-buffered saline and purified by CsCl density gradient centrifugation. All procedures prior to the CsCl centrifugation were carried out at room temperature to prevent the agar and gelatin from solidifying.

In a later stage of this study, we developed a simpler method for isolation of the released FHR complexes. SJW3060 cells were grown overnight in 1 liter of medium containing 5% yeast extract and 2% polyethylene glycol 6000. The cells and the released bundles of FHR complexes were collected by low-speed centrifugation. After dissociating the bundles into individual FHR complexes by suspension in phosphate-buffered saline, the cells were removed by low-speed centrifugation. The FHR fraction was further purified as described above.

**Disruption of hook-basal body structures.** Hook-basal body (HBB) complexes (50- $\mu$ l sample in an Eppendorf tube) were subjected to ultrasonication for 15 min in the water bath of a Velvo ultrasonic cleaner.

**Introduction of *che* phenotype into SJW3060.** The construction of double mutants was carried out by P22 transduction as follows. First, a large deletion was introduced into region II of the SJW3060 flagellar genes. Then, various mutations of *che* genes were transduced into region II of this deletion mutant by P22. A similar procedure was used for introducing region III *fliA* mutations into SJW3060.

**Antibodies.** Antihook antibody was kindly provided by S. Asakura of Nagoya University. Antiflagellin antibody was

raised against purified flagella in a rabbit by conventional procedures.

## RESULTS

**Behavior of SJW3060 on semisolid plates and in viscous media.** The mutant strain SJW3060 could be isolated because it produced much smaller swarms than the wild type on a semisolid plate (Fig. 1). Although the null phenotype associated with *fliF* is nonflagellate, SJW3060 swam vigorously in liquid. Neither the swimming speed nor the tumbling frequency of the mutant was distinguishable from that of the wild type.

Bundles of detached filaments up to 100  $\mu$ m long were found on the surface of semisolid plates by light microscopy. To reproduce this phenomenon, the mutant was grown in a viscous medium containing 4% gelatin and observed by dark-field microscopy (Fig. 2). When the cell density became high enough, the filaments became tangled into bundles. Although the cells trapped in bundles could not swim, they eventually freed themselves by leaving their tangled filaments behind. The motility of the freed cells was impaired, presumably because of poor flagellation.

**Electron microscopy of ejected FHR complexes from SJW3060.** When the purified filaments were observed by

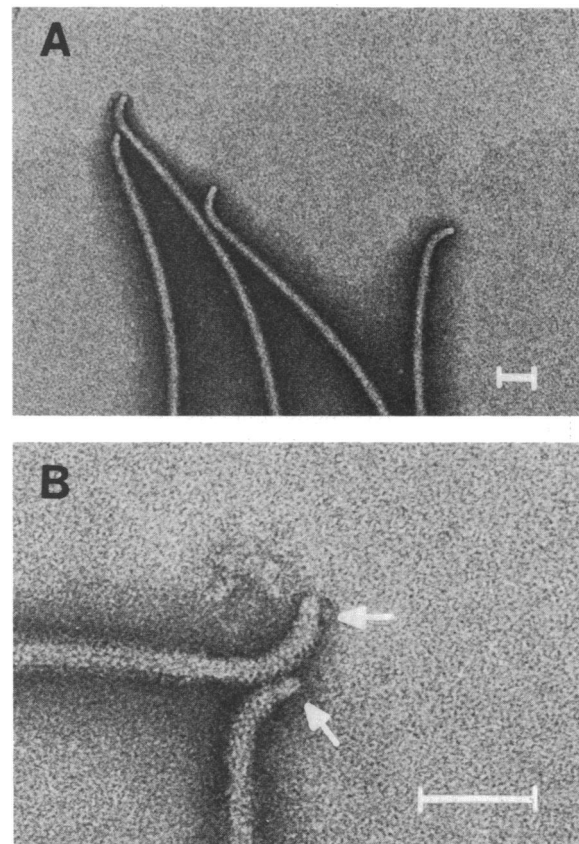

FIG. 3. (A) Electron micrograph of released FHR complexes from SJW3060 cells. (B) The hook region of the complexes was observed at a high magnification. The stain pattern of the tip of the hook (arrows) looks different from that of the remainder. Bars, 100 nm.

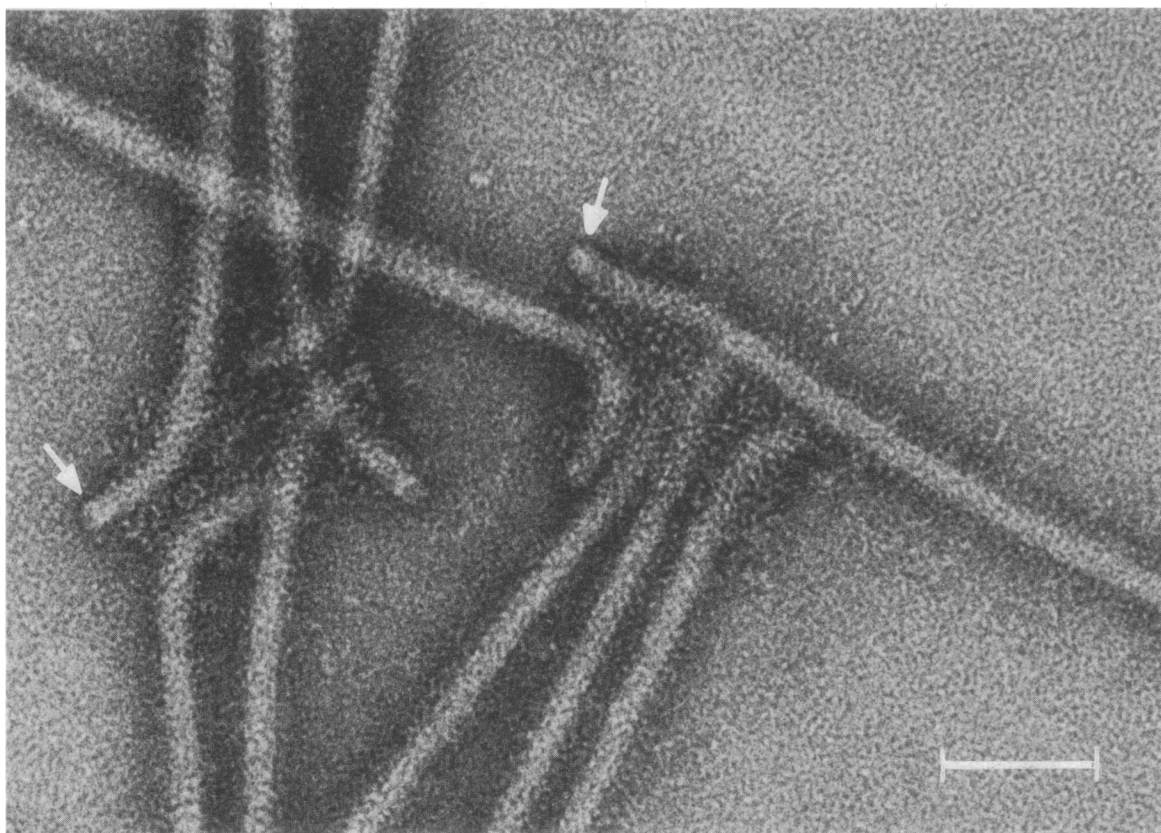

FIG. 4. Immunoelectron micrograph of FHR complexes from the SJW3060 cells. When the complexes were mixed with antihook antibody, the hook appeared decorated with antibody, but the tip did not (arrows). Bar, 100 nm.

electron microscopy, most of them were found to have retained the hook at their proximal end. Electron micrographs at higher magnifications revealed that at the tip of the hook there was a structure different from the hook itself (Fig. 3). Thus, they are not really filaments, but FHR complexes.

The diameter of the rod of the FHR complexes released from SJW3060 cells was about 18 nm, almost as large as that of the hook (Fig. 3). Its length varied somewhat but never exceeded 20 nm.

To confirm this observation, immunoelectron microscopy was carried out. The FHR complexes were mixed with antihook antibody and observed by electron microscopy. Although the hook was decorated as expected, the proximal end of the hook was not (Fig. 4). The length of the undecorated part was 20 nm at most.

**SDS-polyacrylamide gel electrophoresis of FHR complexes from SJW3060.** The purified FHR complexes were treated with acidic buffer (50 mM glycine-HCl, pH 2.5) to depolymerize the filament, and the part remaining intact was examined by SDS-polyacrylamide gel electrophoresis and two-dimensional gel electrophoresis.

In SDS gels, the sample showed several bands with the same molecular weights (60,000, 53,000, 42,000, and 30,000) as those of components of the basal body (Fig. 5) (1). From the positions of the spots in two-dimensional gels, they were identified as HAP1, flagellin, hook protein, and the 30-kDa protein, respectively (Fig. 6) (1). The amount of undepolymerized flagellin varied from preparation to preparation. When the filament was entirely depolymerized, the amounts of the 60- and 30-kDa proteins were greatly reduced, indicating that HAP1 and the rod structures were breaking down

by a prolonged incubation in acidic buffer. The basal body has a 32-kDa component in SDS gels (1). We often saw a 32-kDa band in FHR preparations (Fig. 5, lane B). However, the protein was regarded as a contaminant, because it was

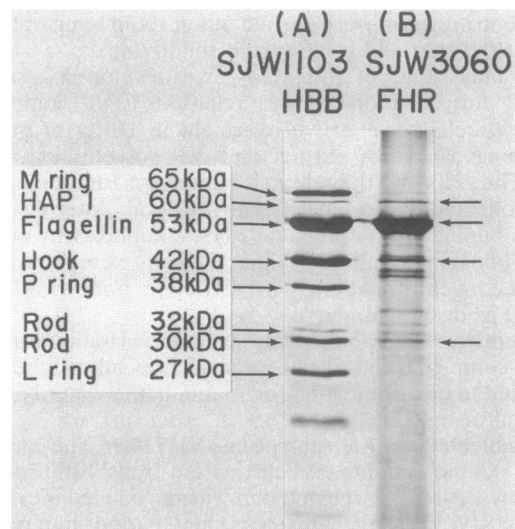

FIG. 5. Identification of the component proteins in the hook preparation from the FHR complexes by SDS gel electrophoresis. Lane A, HBB complex of SJW1103; lane B, FHR preparation of SJW3060. Arrows in lane B show bands with the same molecular weights as those of components of the HBB complex in lane A.

not detected at the position of the 32-kDa protein in two-dimensional gels (the dotted circle in Fig. 6).

We therefore concluded that the tip portion of the FHR structure was constructed from the 30-kDa protein.

**Rod structure of the flagellar basal body.** With a wild-type strain, the M and S rings are firmly connected to the rod and seldom come apart from the basal body. However, sonication of the basal body sample gave rise to partial destruction of the structure. Electron microscopy of these sonicated basal bodies revealed a few particles lacking the M and S rings (Fig. 7). The rods were exposed and stained well in these broken basal bodies. The diameter of the exposed rod is 13 nm, on the basis of comparison with the 20-nm-diameter hook.

It has been thought that the rod consists of two proteins with apparent molecular masses of 30 and 32 kDa, products of the *flgG* and *flgF* genes (1, 8). The rod portion of the FHR complexes released from the SJW3060 cells consists of the 30-kDa protein, as mentioned above.

These results lead us to the conclusion that the rod is not a simple structure but is composed of two cylinders end-to-end: the upper rod (close to the hook), consisting of the 30-kDa protein, and the lower rod (by inference), consisting of the 32-kDa protein.

**Behavior of SJW3060 derivative strains with altered switching probability.** To investigate the manner of formation of the large bundles in further detail, we constructed strains with double mutations, the SJW3060 mutation in the *fliF* gene and the other in one of the *che* or *fla* genes.

The behavior of these mutants on semisolid plates and in viscous media is summarized in Table 2. When a *cheY* mutation (SJW2903) was introduced into SJW3060, flagellar rotation of the double mutant (SJW3094) was strongly biased to a counterclockwise (CCW) direction and the cells swam smoothly. These cells did not form large ejected bundles and could not be distinguished from the original *che* mutants on semisolid plates.

When a *cheZ* mutation (from SJW3039 or 3092) was combined with an SJW3060 mutation, the double mutants (SJW3091 and 3093) showed tumbling swimming. Unlike the

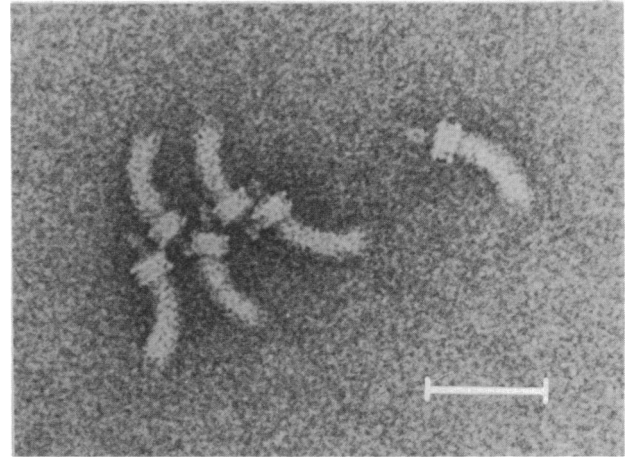

FIG. 7. Electron micrograph of partially damaged basal bodies of the wild-type strain SJW1103. HBB complexes from SJW1103 were sonicated and examined by electron microscopy. Basal bodies without the M and S rings were often found in clusters rather than scattered uniformly over the grid. Bar, 100 nm.

smooth-swimming mutants described above, these tumbling mutants formed large detached bundles and did not produce swarms on semisolid plates. When the cells were tethered (18) and observed by microscopy, they were moderately biased to a clockwise (CW) direction.

When a *fliM* (*che*) (SJW2298) mutation was introduced into SJW3060, the double mutant (SJW3096) showed inverse swimming (12) in liquid and tethered cells spun in a CW direction all the time. In viscous media, these cells formed tangled bundles. However, the cells remained attached to the bundles, and therefore the bundles could not grow larger.

**Forced release of FHR complexes by antibodies.** The filaments of smooth-swimming cells do not tangle together (see Discussion). Since bundle formation is necessary for the release of FHR complexes, tangled bundles of filaments of

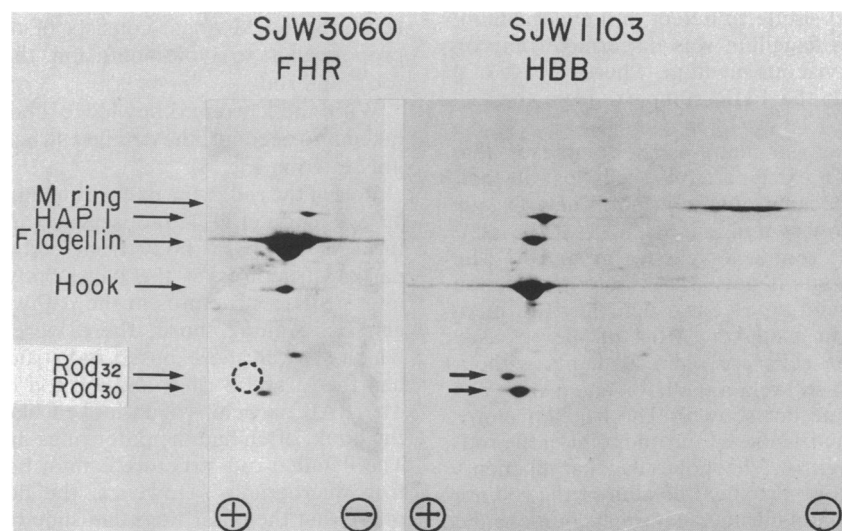

FIG. 6. Identification of the 30-kDa protein in the hook preparation from FHR complexes by two-dimensional electrophoresis. Two-dimensional gel pattern of the HBB complex from SJW1103 (right) and acidic region of two-dimensional gel of the FHR preparation from SJW3060 (left). The 30-kDa protein is present in both preparations, but the 32-kDa protein spot is missing in the FHR preparation (dotted circle).

TABLE 2. Formation of large bundles by derivatives of SJW3060

Strain	Relevant genotype	Swarm size on semisolid plate	Swimming pattern	Rotation pattern <sup>a</sup>	Formation of large bundles
SJW1103	Wild type	Large	Normal	Normal	-
SJW3060	<i>fliF</i>	Small	Normal	Normal	+ <sup>b</sup>
SJW2903	<i>cheY</i>	Small	Smooth	CCW only	-
SJW3094	<i>fliF cheY</i>	Small	Smooth	CCW only	-
SJW3039	<i>cheZ</i>	Small	Tumbly	Biased to CW	-
SJW3091	<i>fliF cheZ</i>	Small	Tumbly	Biased to CW	+
SJW3092	<i>cheZ</i>	Small	Tumbly	Biased to CW	-
SJW3093	<i>fliF cheZ</i>	Small	Tumbly	Biased to CW	+
SJW2298	<i>fliM</i>	Small	Inverse smooth	CW only	-
SJW3096	<i>fliF fliM</i>	Small	Inverse smooth	CW only	-

<sup>a</sup> Pattern of the tethered cells.

<sup>b</sup> Large bundles up to 100  $\mu\text{m}$  visible with phase-contrast microscopy after overnight incubation at 37°C with shaking in 4% gelatin-L broth.

these cells were forcibly formed by adding anti-flagellin antibody.

When antibody was added to wild-type cells and the cell suspension was observed by dark-field microscopy, aggregates of cells formed within a minute and grew bigger with time. Cells on the surface of the aggregates were actively motile, and whole aggregates moved jerkily. SJW3060 cells under the same conditions formed smaller aggregates which often broke down into several pieces and moved jerkily, suggesting the release of FHR complexes from the cells.

When various switching mutants of SJW3060 were mixed with antibodies, the results were basically the same as those with SJW3060. Breakage of aggregates into smaller pieces happened more often with SJW3060 mutants moderately biased to CW than in mutants strongly biased to CW or CCW.

## DISCUSSION

Strain SJW3060 has a mutation in the *fliF* gene, which is the structural gene for the component protein of the M ring of the basal body. Basal bodies isolated from this mutant did not show any differences from the wild type by electron microscopy or SDS-polyacrylamide gel electrophoresis (data not shown). Any functional aberration of the motor caused by the mutation was too subtle to detect in liquid medium. The altered state of the flagellum was discernible only on semisolid plates or in a viscous medium, where release of a portion of the flagellum, the FHR complex, from the cell occurred.

SJW3060 cells released so many FHR complexes that motility was impaired. In extreme cases, cells lost all their flagellar filaments and became nonmotile until new flagella grew long enough to allow swimming.

**Is the release of FHR complexes passive or active?** The release of flagellar filaments is not an unusual phenomenon and occurs even with wild-type cells when they are incubated for a long time in a shaker. Most of the released filaments from wild-type cells are plain filaments without hooks, but some of them still retain the hook and a short rod portion at their ends (data not shown). The flagellar motor seems to have an intrinsic fragility at the midpoint of the rod.

In *Caulobacter crescentus*, the polar flagellar filaments with the hook and the hook-proximal portion of the rod are shed into the culture medium during the normal course of the cell cycle (11). *C. crescentus* is a dimorphic bacterium in which a nonmotile stalked cell divides repeatedly to produce motile swarmer cells. The mechanism by which the filament is shed into the medium is not understood, but the phenom-

enon suggests structural fragility of the rod. Our results suggest that the rod of *S. typhimurium* has a similar, though normally latent, fragility.

**Detailed structure of the flagellar basal body.** The intact rod structure of the basal body cannot readily be seen by electron microscopy because most of it is obscured by the four rings. Even the part exposed (between the S and P rings) is difficult to see because of incomplete penetration of the stain.

The M and S rings seldom come apart from the basal body. However, when they do, the rods are exposed. The diameter of the rod is 13 nm, on the basis of comparison with the 20-nm-diameter hook, whereas the diameter of the rod of the flagella released from SJW3060 cells is 18 nm. The length of the intact rod is estimated to be about 30 nm. However, the length of the rod of released flagella measures at most 20 nm, which is equivalent to the length of the part covered by the outer rings. We suggest that the rod consists of two proteins, the 30- and 32-kDa proteins. The rod portion of the flagella released from the SJW3060 cells consists of the 30-kDa protein only.

These results lead us to the conclusion that the rod consists of two parts, where the upper rod (close to the hook) consists of the 30-kDa protein and the lower rod (close to the S and M rings) consists of the 32-kDa protein. We propose that, to avoid confusion, these two parts be called rod<sub>30</sub> and rod<sub>32</sub>.

With the current knowledge about the flagellar motor taken into account, the detailed structure of the basal body is illustrated in Fig. 8.

**Role of the rod in the pathway of flagellar morphogenesis.** In 1978, Suzuki et al. (20) observed various kinds of substructures of the basal body from certain *fla* mutants. These partial structures of the basal body were assumed to be intermediate structures in the pathway of flagellar morphogenesis. Among those, there were several substructures which showed the exposed rod structure. The RIV particle had the M and S rings and the rod but not the outer rings. The BAB particle, which looked like a basal body without the hook, often had the outer rings dissociated from the rod. The detailed rod structure cannot be seen from those electron micrographs. However, the defective BAB particles prove that the outer rings can slide towards the hook, while they have never been observed to move towards the M and S rings in the intact basal body. These observations strongly suggest that the rod consists of two parts to hold the outer rings at a constant position from the M and S rings.

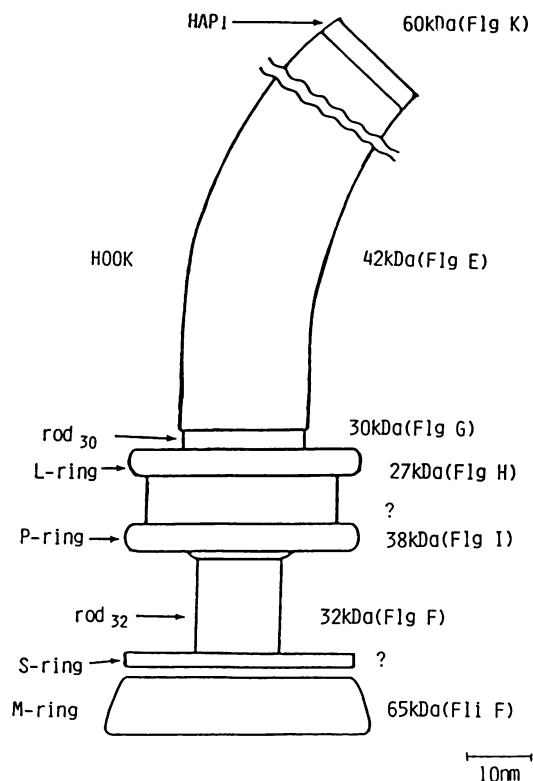

FIG. 8. Schematic model of the detailed structure of the basal body. Dimensions of the substructures were normalized by taking the 20-nm-diameter hook as the standard. The molecular masses of the component proteins and the genes encoding these are shown.

The existence of a differentiated rod is not surprising, since the region surrounded by the outer rings and the region between the P ring and the inner rings are likely to have different requirements.

**FHR release and bundle formation.** It is noteworthy that FHR complexes seldom come off free-swimming SJW3060 cells. The formation of tangled bundles among cells is necessary to pull the FHR complexes off the cell body. The filaments from two different cells will, because of their left-handed helicity, be tangled only when they rotate in a CW direction (Fig. 9) (15). When the flagella rotate in a CCW direction, any point where the two filaments tangle travels down the flagella towards the free end.

Among the various *che* mutants of the SJW3060 strain, mutants weakly biased to CW rotation can form large bundles similar to those of SJW3060 itself. Mutants biased to CW show only inverse swimming (in which the helical handedness of the filaments is converted from left handed to right handed [17]), and therefore their filaments, like those of CCW-biased mutants, do not tangle together. Although both mutants fail to form large bundles, they do lose FHR complexes more easily than the wild type, as demonstrated in the experiments on cell aggregation caused by antibodies.

These results show that the FHR complexes of SJW3060 and its derivatives can be pulled off from the cell body more easily than can those of wild-type cells.

**Rod fragility and the M ring.** SJW3060 has a mutation in the M ring of the basal body, not in the rod. However, the cells swim in liquid as vigorously and with the same switching properties as the wild type. Although the rod protein of SJW3060 is normal, our observations clearly show that the

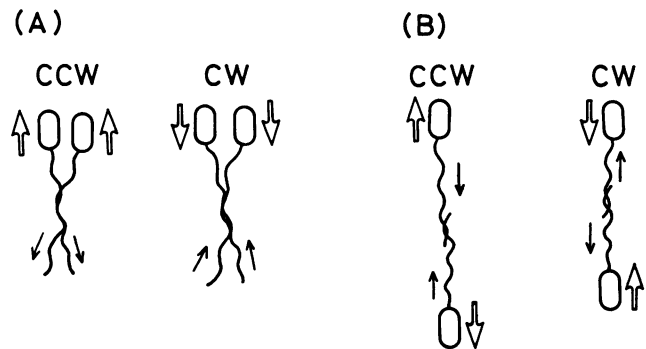

FIG. 9. Hypothetical scheme of the tangling flagellar filaments from two cells. (A) Two cells aligned side by side in parallel. When their flagella rotate in a CCW direction, the crossing point of the two filaments moves towards the free ends (arrows) because of the left-handed helicity of the filament (15). However, CW rotation of the filaments propels the crossing point towards the cell bodies, thus leaving the filaments tangled. Open arrowheads show the direction of movement of the cell bodies. (B) Two cells aligned in antiparallel. CCW rotation of the two flagella causes repulsion of the cells, whereas CW rotation causes the cells to pull toward each other and their filaments to tangle.

rod structure is more fragile than that of the wild type. Therefore, it is very likely that a slight modification of the M ring directly or indirectly induces structural instability in the rod so that the rod cannot withstand the mechanical stress incurred in bundles.

#### ACKNOWLEDGMENTS

We thank Sachiko Kanto for technical help, Hirokazu Hotani for encouragement throughout this study, and Robert Lewis and Ferenc Vonderviszt of ERATO for their critical reading of the early version of the manuscript. We also give special thanks to Robert M. Macnab and Chris J. Jones of Yale University for their careful reading of the text and invaluable comments.

#### LITERATURE CITED

1. Aizawa, S.-I., G. E. Dean, C. J. Jones, R. M. Macnab, and S. Yamaguchi. 1985. Purification and characterization of the flagellar hook-basal body complex of *Salmonella typhimurium*. *J. Bacteriol.* **161**:836-849.
2. Berg, H. C. 1974. Dynamic properties of bacterial flagellar motors. *Nature (London)* **249**:77-79.
3. Berg, H. C., and R. A. Anderson. 1973. Bacteria swim by rotating their flagellar filaments. *Nature (London)* **245**:380-382.
4. DePamphilis, M. L., and J. Adler. 1971. Purification of intact flagella from *Escherichia coli* and *Bacillus subtilis*. *J. Bacteriol.* **105**:376-383.
5. DePamphilis, M. L., and J. Adler. 1971. Fine structure and isolation of the hook-basal body complex of flagella from *Escherichia coli* and *Bacillus subtilis*. *J. Bacteriol.* **105**:384-395.
6. DePamphilis, M. L., and J. Adler. 1971. Attachment of flagellar basal bodies to the cell envelope: specific attachment to the outer, lipopolysaccharide membrane and the cytoplasmic membrane. *J. Bacteriol.* **105**:396-407.
7. Homma, M., S.-I. Aizawa, G. E. Dean, and R. M. Macnab. 1987. Identification of the M-ring protein of the flagellar motor of *Salmonella typhimurium*. *Proc. Natl. Acad. Sci. USA* **84**:7483-7487.
8. Homma, M., K. Ohnishi, T. Iino, and R. M. Macnab. 1987. Identification of flagellar hook and basal body gene products (FlaFV, FlaFVI, FlaFVII, and FlaFVIII) in *Salmonella typhimurium*. *J. Bacteriol.* **169**:3617-3624.
9. Hotani, H. 1976. Light microscope study of mixed helices in reconstituted *Salmonella* flagella. *J. Mol. Biol.* **106**:151-166.

10. Iino, T., Y. Komeda, K. Kutsukake, R. M. Macnab, P. Matsu-mura, J. S. Parkinson, M. I. Simon, and S. Yamaguchi. 1988. New unified nomenclature for the flagellar genes of *Escherichia coli* and *Salmonella typhimurium*. *Microbiol. Rev.* **52**:533-535.
11. Johnson, R. C., M. P. Walsh, B. Ely, and L. Shapiro. 1979. Flagellar hook and basal complex of *Caulobacter crescentus*. *J. Bacteriol.* **138**:984-989.
12. Khan, S., R. M. Macnab, A. L. DeFranco, and D. E. Koshland, Jr. 1978. Inversion of a behavioral response in bacterial chemo-taxis: explanation at the molecular level. *Proc. Natl. Acad. Sci. USA* **75**:4150-4154.
13. Laemmli, U. K. 1970. Cleavage of structural proteins during the assembly of the head of bacteriophage T4. *Nature (London)* **227**:680-685.
14. Macnab, R. M. 1976. Examination of bacterial flagellation by dark-field microscopy. *J. Clin. Microbiol.* **4**:258-265.
15. Macnab, R. M. 1977. Bacterial flagella rotating in bundles: a study in helical geometry. *Proc. Natl. Acad. Sci. USA* **74**: 221-225.
16. Macnab, R. M., and S.-I. Aizawa. 1984. Bacterial motility and the bacterial flagellar motor. *Annu. Rev. Biophys. Bioeng.* **13**:51-83.
17. Macnab, R. M., and M. K. Ornston. 1977. Normal-to-curly flagellar transitions and their role in bacterial tumbling: stabil-ization of an alternative quaternary structure by mechanical force. *J. Mol. Biol.* **112**:1-30.
18. Manson, M. D., P. M. Tedesco, and H. C. Berg. 1980. Energetics of flagellar rotation in bacteria. *J. Mol. Biol.* **138**:541-561.
19. O'Farrell, P. H. 1975. High-resolution two-dimensional electro-phoresis of proteins. *J. Biol. Chem.* **250**:4007-4021.
20. Suzuki, T., T. Iino, T. Horiguchi, and S. Yamaguchi. 1978. Incomplete flagellar structures in nonflagellate mutants of *Sal-monella typhimurium*. *J. Bacteriol.* **133**:904-915.
21. Yamaguchi, S., S.-I. Aizawa, M. Kihara, M. Isomura, C. J. Jones, and R. M. Macnab. 1986. Genetic evidence for a switch-ing and energy-transducing complex in the flagellar motor of *Salmonella typhimurium*. *J. Bacteriol.* **168**:1172-1179.
22. Yamaguchi, S., H. Fujita, S.-I. Aizawa, R. M. Macnab, and A. Ishihara. 1986. Subdivision of flagellar genes of *Salmonella typhimurium* into regions responsible for assembly, rotation, and switching. *J. Bacteriol.* **166**:187-193.
23. Yamaguchi, S., H. Fujita, K. Sugata, T. Taira, and T. Iino. 1984. Genetic analysis of H2, the structural gene for phase-2 flagellin in *Salmonella*. *J. Gen. Microbiol.* **130**:255-265.