

STUDIES IN PORPHYRIA

IV. Expression of the Gene Defect of Acute Intermittent Porphyria in Cultured Human Skin Fibroblasts and Amniotic Cells: Prenatal Diagnosis of the Porphyric Trait*

By S. SASSA,† G. SOLISH, R. D. LEVERE, AND A. KAPPAS

(From The Rockefeller University Hospital, New York 10021 and the State University of New York, College of Medicine, Brooklyn, New York 11203)

The genetic liver disease, acute intermittent porphyria (AIP),¹ is characterized biochemically by the excessive production and excretion into urine of the tetrapyrrole precursors, δ -aminolevulinic acid (ALA) and porphobilinogen (PBG). This unique excretion pattern of intermediates of the porphyrin-heme pathway distinguishes AIP from the two other hereditary forms of hepatic porphyria, variegate porphyria and hereditary coproporphyria. Increased activity of the porphyrin-heme synthetic pathway in all three genetic disorders results from increased hepatic levels of ALA-synthetase, the mitochondrial enzyme which is rate-limiting for the pathway (Z1).

It is only in AIP, however, that excessive amounts of porphyrin precursors rather than of porphyrins themselves are produced, suggesting that there is in this disease a biochemical defect of the pathway localized at a step after the formation of PBG. Indeed, the activity of the hepatic enzyme which catalyzes the formation of uroporphyrinogen I from PBG—uroporphyrinogen I synthetase (URO-S)—has been shown to be considerably decreased from normal levels in AIP but not in other forms of hereditary hepatic porphyrias (2, 3). More recently, Meyer et al. (4, 5) and our own group (6, 7) have shown that URO-S activity is also markedly deficient in the erythrocytes of AIP patients. The decreased activity of URO-S in AIP subjects readily accounts for the impaired conversion of PBG to porphyrins and thus the excessive excretion of both ALA and PBG into urine.

One parent of each set and certain siblings and offspring of AIP patients display low levels of erythrocyte URO-S activity; pedigree studies clearly show that this enzyme deficiency is inherited in an autosomal dominant pattern (4–7). AIP patients, as well as their relatives with low URO-S activities, thus represent the heterozygous state for the gene defect of this enzyme, and such individ-

* These studies were supported by U.S. Public Health Service General Clinical Research Center grant RR-102, National Foundation grant I-350, and National Foundation Birth Defect contract no. 74140.

† Recipient of a Career Scientist Award (I-768) from the Health Research Council of the City of New York.

¹ *Abbreviations used in this paper:* ALA, δ -aminolevulinic acid; AIP, acute intermittent porphyria; PBG, porphobilinogen; URO-S, uroporphyrinogen I synthetase.

uals may be considered to be carriers of the AIP trait. However, it is clear (7) that a deficiency of URO-S activity does not, in itself, account for the clinical syndrome characterizing AIP, and that endocrine (8–10) as well as other metabolic factors must be involved in determining the clinical expression of the disorder.

In this report we show that the URO-S defect found in the liver and erythrocytes of AIP subjects can readily be identified in cultured skin fibroblasts from such patients, utilizing a newly developed, simple, and sensitive assay for detection of this enzymatic abnormality. In addition, in studies of cultured human amniotic cells, evidence has been obtained which has permitted us to make the first prenatal diagnosis of the gene carrier state for AIP.

Materials and Methods

Study Subjects. A total of eight AIP patients were studied with skin fibroblast cultures. They were females with the age range of 31–60. The diagnosis of AIP was established by characteristic clinical features together with an excessive urinary ALA and PBG excretion, in addition to the decreased erythrocyte URO-S activity typical for AIP patients (4–7). A matched group of 12 normal subjects was studied as controls.

Human amniotic cells were obtained by amniocentesis from a total of 25 pregnant females during induced abortion requested by the mothers and performed with written consent at the SUNY Downstate Medical Center. The age of the aborted fetuses ranged from 13 to 22 wk and that of the mothers was 14–33 years. Amniotic cells were also obtained from a pregnant AIP female at her request during the 17th wk of gestation. Ultimately the mother decided to allow the pregnancy to go on to completion.

Cell Cultures. An approximately 0.5 x 1 x 3 mm piece of skin specimen was biopsied from the upper forearm and cut into 7–10 pieces in 1 ml of growth medium in a 60-mm dish. The growth medium was Ham F12-20% heat-inactivated fetal bovine serum containing penicillin (100 U/ml) and streptomycin (100 µg/ml) (F12-20% FBS). Mycostatin was not included since it was found slightly inhibitory for cell growth at a concentration of 25 U/ml. Phenol red was also avoided since it interferes with the porphyrin fluorescence assay. The fetal bovine serum (Grand Island Biological Co., Grand Island, N.Y.) used was a batch previously selected for optimum ability to support cell growth. Two–three pieces of skin specimens were then transferred into each of three 25-cm² plastic culture flasks (Falcon no. 3013, Falcon Plastics, Div. of BioQuest, Oxnard, Calif.) with a minimum amount of F12-20% FBS. They were incubated at 37°C for 1–2 h to allow adhesion to the flask. Then 5 ml of F12-20% FBS was gently introduced into the flask and the cells were incubated at 37°C in 5% CO₂-95% air. The growth medium was replenished approximately every 2 wk at the beginning of culture, then subsequently every week.

When the fibroblasts reached local confluency, approximately 3–6 wk after the initiation of culture, the cells were rinsed with 5 ml Earle's buffer salt solution devoid of Ca⁺⁺ and Mg⁺⁺, then incubated with 1.0 ml 0.25% trypsin-0.02% EDTA (GIBCO) at 37°C for 5–10 min. After the cells were detached from the flask as a suspension of single cells, 10 ml of F12-20% FBS was added and two 5-ml aliquots were transferred to 25-cm² flasks. In this way, cells were subcultured three-four times for approximately 3 mo to obtain sufficient quantities of cells.

Cells obtained from 20–50 ml of human amniotic fluid were grown in 75-cm² culture flasks (Falcon, no. 3024) in McCoy's 5A medium supplemented with 20% heat-inactivated fetal bovine serum or F12-20% FBS. In some instances cell suspensions in amniotic fluid were incubated without supplementation of growth medium. After the cells were attached to the flask, growth medium was provided. Amniotic cells were subcultured as described for skin fibroblasts. After approximately 2–10 wk of growth in F12-20% FBS, sufficient numbers of cells were obtained to perform enzyme assays.

URO-S Assay in Cultured Amniotic Cells. The fluorometric microassay for URO-S activity in erythrocytes described by Sassa et al. (7) was applicable to these cells with minor modification (60°C incubation rather than 37°C). 1 day before the experiment, the medium of early confluent cultures was changed to a fresh medium (F12-20% FBS) and the cells were incubated for a further

24 h before harvesting before the assay. The cells were harvested from a 75-cm² flask by 0.25% trypsin-0.02% EDTA (pH 7) and washed once in 10 ml of F12-10% FBS and successively twice in 5 ml of Earle's buffer salt solution. The final cell pellet was suspended in 200 μ l of 0.1 M phosphate buffer (pH 7.4) and homogenized in a microhomogenizer equipped with a teflon pestle. 20 μ l of the homogenate was mixed with 5 μ l of 500 μ M porphobilinogen (PBG) in 0.1 M phosphate buffer (pH 7.4) in a 6 x 50 mm disposable glass tube and sealed with a piece of parafilm. The mixture was then incubated in duplicate at 60°C for 1 h in the dark. Incubation was terminated by cooling the tube in ice and the product, URO, was extracted as described previously (7). Porphyrin fluorescence was determined in the same incubation tube without transfer of the material by inserting the tube into the specially constructed microcell holder shown in Fig. 1. This cell holder was designed to fit the

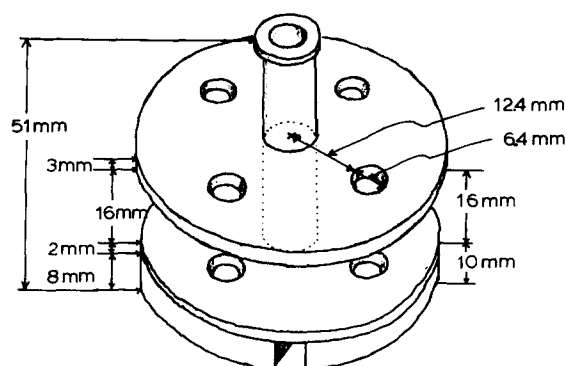

FIG. 1. A microcell holder (6-mm diameter tubes) for the Hitachi-Perkin Elmer fluorescence spectrophotometer. The holder was modified after a Perkin-Elmer microcell holder (cat. no. 010-0501).

cell component of the Hitachi-Perkin Elmer MPF series spectrofluorometer (Hitachi-Perkin Elmer Instruments, Norwalk, Conn.) and greatly facilitates the microassay which was developed for this enzyme activity (7). Two control tubes were run: one tube was without cell material for a control on the nonenzymatic conversion of PBG to porphyrin, the other control was run without PBG in order to determine endogenous levels of porphyrin. These controls were incubated and treated as described above and the sum of the two sets of control values was subtracted from the experimental value. The range of the sum control values was 33–74% those of the complete mixture.

ALA-Conversion to Porphyrin by Cultured Skin Fibroblasts. The ability of skin fibroblasts in culture to convert ALA or PBG to porphyrins was studied with the intent to develop a precise assay for detecting the presence of URO-S deficiency in such cells, since as noted above with amniotic cells the considerable extent of nonenzymatic conversion of PBG to porphyrin in the direct URO-S assay on homogenized cells may introduce potential errors in the assay. Fibroblasts grown in 25-cm² flasks were subcultured as described above and approximately 6–9 x 10⁵ cells were placed into each 1.8-cm² well of a FB16-24TC plate (Linbro Chemical Co., Inc.) with 0.5 ml of F12-20% FBS. A total of 24 wells was prepared for each study subject. After 6 days of growth, medium was removed and 1 ml of Ham F12 supplemented with insulin (1 μ g/ml) (F12-Insulin) was added. 10 μ l of ALA (10 mg/ml) was added to the growth medium and incubation was continued for 24 h, at 37°C in 5% CO₂-95% air. After the incubation, the medium was removed and the cells were washed once with 1 ml Earle's buffer salt solution. In order to extract porphyrins 500 μ l of 1N perchloric acid-methanol (1:1 vol/vol) mixture was then added to the cells with gentle rotation. After 5 min the perchloric-methanol solution was removed into a 6 x 50 mm glass tube and the fluorescence of the extract was determined in the micro-cell holder shown in Fig. 1. In order to determine protein concentration, 200 μ l of 0.5 N NaOH was added to the cells and they were heated at 60°C for 1 h, then diluted up to 1 ml with water. Protein concentration was determined on the cellular digests by the method of Lowry et al., using bovine serum albumin as standard (11).

Results

URO-S Activity in Cultured Amniotic Cells. The activity of URO-S was demonstrable directly in cells centrifuged from fluid derived from the amniocentesis procedure. However, meaningful results could not be obtained by utilizing such cells because of the presence of contaminating erythrocytes and numerous dead amniotic cells. By growing amniotic cells in tissue culture, however, it was possible to cultivate sufficient quantities of viable cells for the enzyme assay.

The use of elevated temperature to increase the sensitivity of the URO-S assay was proposed by Meyer (12). This procedure takes advantage of the unusual heat stability of URO-S, e.g., the T/2 of this enzyme activity at 70°C is 45 min (7). Although the other enzyme involved in formation of the type III uroporphyrinogen isomer, URO-cosynthetase, is destroyed at this temperature (13, 14), the rate of formation of total uroporphyrinogen is not affected, since URO-S which is highly heat-stable is rate-limiting for tetrapyrrole formation from PBG (5, 7, 13, 14).

The rate of the URO-S reaction is increased approximately fourfold at 60°C as compared to 37°C. The course of the reaction is linear with time for 60 min, and the complete mixture, i.e. enzyme plus substrate, is required for maximal porphyrinogenesis (15). The rate of enzyme activity is also directly proportional to the amount of enzyme protein added to the mixture (15).

The results of a number of experiments utilizing cultured amniotic cells are summarized in Table I. The mean value of URO-S activity in amniotic cell cultures from 25 pregnant females was $57.4 \pm \text{SE of } 5.2$ pmol URO/mg protein, h, 60°C. These data demonstrate that cultured amniotic cells are able to condense 4 mol of the monopyrrole PBG to the tetrapyrrole uroporphyrinogen. Other evidence obtained in our laboratory indicates that the entire biosynthetic sequence for heme exists in cultured amniotic cells. However, the potent inducer of ALA-synthetase in liver cells, allylisopropylacetamide, does not stimulate porphyrinogenesis in amniotic cells, suggesting that the response of amniotic cells to exogenous chemicals may be quite different from that of liver cells (16).

ALA Conversion to Porphyrin by Cultured Skin Fibroblasts. When cultured fibroblasts were incubated in the presence of PBG, the immediate substrate for URO-S, the monopyrrole proved to be extremely cytotoxic even when added in very low concentrations to the cultures. However, it proved possible to circumvent this problem by adding ALA (100 $\mu\text{g/ml}$), the precursor of PBG, to the cultures rather than the monopyrrole itself. Viability of cells was more than 95% for both untreated and ALA-treated cells as judged from trypan blue exclusion. When the cells were incubated with ALA in F12-Insulin for 24 h, the porphyrin accumulation was linearly increased as a function of ALA concentration up to 50 $\mu\text{g/ml}$ (Fig. 2). When the cells were incubated in F12-Insulin with ALA 100 $\mu\text{g/ml}$, porphyrin in the cells increased essentially linearly until 24 h (Fig. 3). However, when the medium contained 10~20% FBS, porphyrin accumulation in the cells was less than $1/10$ that obtained when the cells were incubated with F12-Insulin (Figs. 2, 3), in keeping with the comparable findings of Granick et al. (17), who used cultured avian hepatic cells. The decreased porphyrin accumulation in the cells in the serum-containing medium was due both to inhibition of

TABLE I
URO-S Activity in Erythrocytes and Cultured Amniotic Cells from a Child Carrying the AIP Gene Defect Born to a Woman with Clinically Manifest AIP

Cells	URO-S activity	
	Erythrocytes*	Amniotic cells
	<i>nmol URO/ml RBC, h, 37°C</i>	<i>pmol URO/mg protein, h, 60°C</i>
Mother (active AIP), 32 yr	14.5	
Father (normal), 32 yr	26.1	
Baby (AIP carrier), 15 mo	11.2	0-12‡
Son 1 (normal), 11 yr	32.0	
Son 2 (AIP carrier), 4 yr	13.4	
Mother's sister (normal), 30 yr	32.4	
Normal subjects	28.7 ± 6.8 (64)§	57.4 ± 5.2 (25)§
AIP patients	15.3 ± 4.5 (10)§	

* Assays were performed as described in ref. 7 with 100 μ M PBG.

‡ A range of three determinations.

§ Mean ± SE (number of cases).

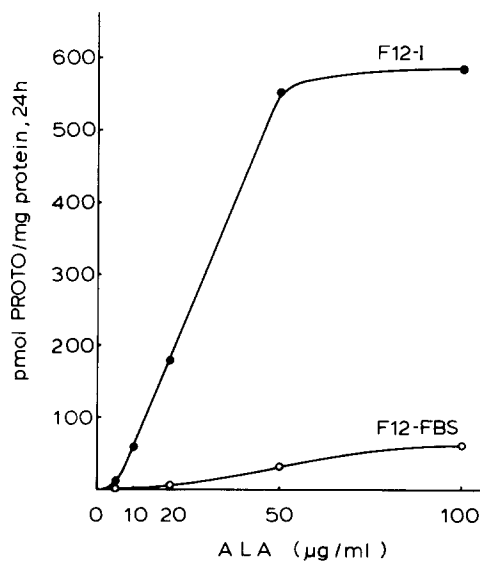

FIG. 2. Porphyrin accumulation in cultured human skin fibroblasts as a function of ALA concentration. Cells were incubated at 37°C for 24 h in the presence of either F12-Insulin (●—●) or F12-10% FBS (○—○) together with ALA. Essentially all the porphyrin formed was identified as protoporphyrin IX from its characteristic fluorescence emission spectrum. Extraction and quantitation of porphyrin are described in the Materials and Methods section.

porphyrin formation from ALA and to its loss from the cells into the growth medium.

The porphyrin which accumulated in the cells and in the medium was identified by its characteristic fluorescence spectrum (19) and proved to be

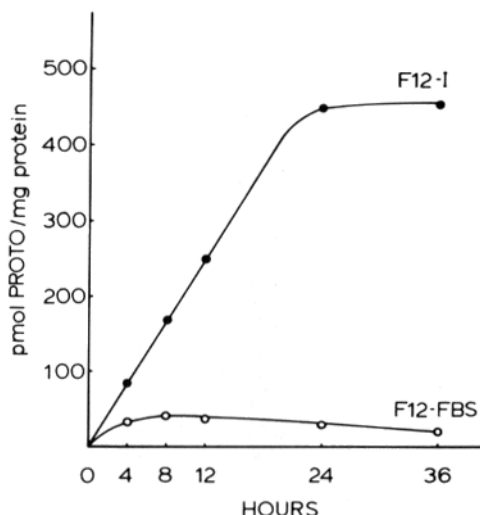

FIG. 3. Porphyrin formation from ALA in cultured human skin fibroblasts as a function of time. Cells were incubated at 37°C with ALA (100 $\mu\text{g}/\text{ml}$) in the presence of either F12-Insulin (●—●) or F12-10% FBS (○—○). Extraction and quantitation of porphyrin are described in the Materials and Methods section.

almost entirely protoporphyrin IX. Since protoporphyrin was formed in large amounts from ALA, it is clear that cultured human skin fibroblasts contain all enzymes of the heme pathway from ALA-dehydratase to coproporphyrinogen decarboxylase in nonlimiting amounts. Other evidence from our laboratory (unpublished data) indicates that the terminal enzyme activity of the heme biosynthetic pathway, i.e., ferrochelatase, is also present in these fibroblasts in culture but becomes limiting under the conditions of these studies. Although ALA-dehydratase activity in fibroblasts is too low to measure using the presently available colorimetric assay techniques, it can be reasonably supposed that this enzyme activity in AIP fibroblasts is not different from those of normals, since ALA-dehydratase activity in erythrocytes of AIP patients is normal (6). Moreover, there is no indication in this disorder for a decrease in ALA-dehydratase activity as judged from the excretion pattern of porphyrin precursors; and specific data showing normal levels of the enzyme activity in AIP liver have been provided by Nakao et al. (20).

The results of the experiments with ALA additions to the fibroblast cultures are summarized in Fig. 4. The mean protoporphyrin formation from ALA by skin fibroblasts from 12 normal individuals was 547 with $\text{SE} \pm 18$ pmol protoporphyrin/mg protein, 24 h. In contrast, the mean value for cells from eight AIP patients was 192 with $\text{SE} \pm 14$ pmol protoporphyrin/mg protein, 24 h—approximately 40% of the value found in normals ($P < 0.001$). It can thus be concluded that the rate-limiting step of protoporphyrin formation from ALA in these cultured cells is at the level of URO-S and that the markedly decreased URO-S activity in cells from AIP patients may be readily detected by determining the porphyrin concentration in the cells after incubation with ALA.

URO-S activity directly assayed in these cells was 40.9 ± 11.8 (mean \pm SE)

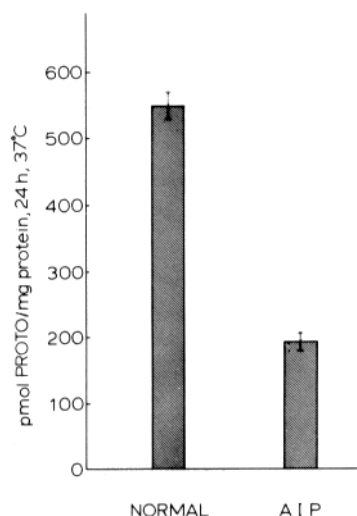

FIG. 4. Porphyrin formation from ALA in cultured skin fibroblasts from 12 normal subjects and 8 AIP patients. The height of the columns represents a mean value with the SE indicated for each group.

pmol URO/mg protein, h, 60°C, for six normal individuals and 12.4 ± 2.7 pmol URO/mg protein, h, 60°C, for five AIP patients. Thus, it was also possible to show the gene defect of the AIP disorder by the direct enzyme assay, confirming the findings of Meyer (12), and Bonkowsky et al. (18). However, the levels of the enzyme activity in AIP fibroblasts were at the lowest limit of detection of the assay, thus introducing potential inaccuracy in the determination. On the other hand, our new technique of quantitation of porphyrin formation from ALA by fibroblasts in culture yields far better reproducibility plus greater sensitivity and ease of application while reflecting the genetically determined decrease in level of URO-S in the cells from AIP patients.

Prenatal Diagnosis of a Gene Carrier of AIP. Amniotic cells derived from a pregnant patient with clinically manifest AIP who had low URO-S activity in both her skin fibroblasts and erythrocytes, exhibited a markedly lower level of URO-S activity compared to normals (Table I). Other enzymes used as markers, e.g., glucose-6-phosphate dehydrogenase, were normal (data not shown) in the amniotic cells of this fetus; therefore the deficiency of URO-S activity found in the amniotic cells was a specific defect of this fetus.

This pregnancy went on to completion and 15 mo after birth, the child, a girl, exhibited a deficient level of erythrocyte URO-S activity typical of that which characterizes AIP patients—including the mother, and which was one-half the level of the enzyme activity found in the erythrocytes of her normal father, normal aunt, and normal sibling (Table I). The diagnosis was further confirmed by a decreased porphyrin formation from ALA in the child's skin fibroblasts in culture.

Discussion

The results of the present study indicate that in AIP patients a marked deficiency of URO-S activity can be easily detected in cultured skin fibroblasts

by quantitating the ability of such cells to synthesize protoporphyrin from the porphyrin precursor, ALA. The extent of the URO-S deficiency found in fibroblasts by this technique is comparable to that found earlier in the liver and erythrocytes of AIP patients, i.e. approximately 50% less than normal (4-7). Though the enzyme deficiency in AIP could be demonstrated directly (Results section) using homogenized fibroblasts with the substrate PBG as also indicated by Meyer (12) and Bonkowsky et al. (18), the quantitative assay of URO-S activity in fibroblast homogenates in our studies presented several major drawbacks, viz there was a wide variation (fivefold) of the enzyme activity, a large amount of tissue was required for the assay (1-2 mg protein), and the levels of the enzyme activity found in AIP cells were at the lowest limit of detection of the method, thus increasing the potential error of the determination. For these reasons, the technique described here for the indirect assay of URO-S activity was developed.

The principle of the assay depends on the fact that ALA enters the cultured fibroblasts, that the cells readily convert the exogenous ALA to protoporphyrin, and that the rate of this conversion is limited solely by the level of URO-S activity in the cells. This assay was made possible by the finding that PBG generated intracellularly from added ALA is not toxic, in contrast to exogenously added PBG which is extremely toxic to the cells. The assay technique is simple and has distinct advantages compared to the direct measurement of URO-S activity. For example, the extraction of porphyrin and its quantitation are easily accomplished and the assay can be performed with the small amount of cells grown in a 1.8 cm² well. The cultured cells accumulate protoporphyrin without significant loss of it into the medium or its further metabolic conversion in the cultures. Thus, the amounts of porphyrin formed exceed by almost fivefold the amounts formed by previously described techniques (18). Moreover, the assay reflects the enzyme activity found in living cells, rather than that expressed in a fraction of a cell homogenate resulting in a great increase in the sensitivity of the assay. Finally, the variability of the assay described is extremely small, replicate determinations from specific cultures having an SE less than $\pm 3\%$.

It should be also noted that the variation found between individuals in normal and in AIP groups by this technique is much smaller than that found in erythrocytes (7) from the same population groups. The reason for the greater variation of erythrocyte enzyme activities is not understood, although it is possible that the specialized turnover and life cycle of red cells complicate the expression of genetically determined levels of enzyme activities in such cells. In keeping with this idea, we have recently demonstrated that URO-S activity is significantly higher in reticulocytes than in mature erythrocytes (unpublished observations).

It was possible, in the course of this study, to demonstrate that cultured amniotic cells derived from a pregnant woman with clinically manifest AIP had a markedly decreased level of URO-S activity as compared with normal cells (Table I). Subsequently, a deficiency of URO-S activity was confirmed in the erythrocytes of the child in question, 15 mo after her birth. This case study thus represents the first demonstration of the diagnosis of an AIP gene carrier in

utero and indicates the potential usefulness of the URO-S assay in amniotic cells for prenatal detection of the AIP gene defect.

Summary

The gene lesion of the porphyrin-heme synthetic pathway in acute intermittent porphyria (AIP) is reflected in a deficient level of activity of the cytosol enzyme uroporphyrinogen I synthetase (URO-S). A marked URO-S deficiency has been demonstrated in the liver and in circulating erythrocytes of individuals with both active and latent AIP. This enzymic abnormality accounts for the excessive production and excretion into urine of the porphyrin precursors, δ -aminolevulinic acid (ALA) and porphobilinogen (PBG) in AIP subjects. In this study, utilizing cell culture techniques, a marked URO-S deficiency has also been demonstrated in skin fibroblasts from AIP patients and in cells derived through amniocentesis from an approximately 17-wk old fetus. The prenatal diagnosis of the AIP trait in this fetus was confirmed postnatally by the demonstration in the child of a deficient level of erythrocyte URO-S activity which was comparable to those found in her AIP mother and an affected sibling and which was approximately one-half the levels characterizing her normal father and aunt and a second unaffected sibling.

The identification of the URO-S deficiency in cultured human fibroblasts from AIP patients was facilitated by a newly developed, sensitive assay for the enzyme activity. In this assay, the ability of such cells to convert ALA to protoporphyrin was quantitated; in the sequence of reactions involved in this transformation, URO-S is limiting so that the gene defect of AIP could be simply and precisely determined by appropriate spectrofluorometry of cell extracts. The technique described has distinct advantages over the direct enzymatic assay for URO-S activity in cultured human skin fibroblasts and permits clear differentiation of AIP carriers from normal individuals.

The authors are indebted to Doctors Karl Anderson and Peter N. Gillette for their clinical assistance, to Mrs. Chin Chang and B. Weiss for excellent technical assistance, and to Miss Ann Marie Quatela for the preparation of this manuscript.

Received for publication 2 June 1975.

References

1. Granick, S. 1966. The induction in vitro of the synthesis of δ -aminolevulinic acid synthetase in chemical porphyria; a response to certain drugs, sex hormones, and foreign chemicals. *J. Biol. Chem.* 241:1359.
2. Strand, J., B. F. Felsher, A. G. Redeker, and H. S. Marver. 1970. Enzymatic abnormality in heme biosynthesis in acute intermittent porphyria. Decreased hepatic conversion of porphobilinogen to porphyrins and increased delta aminolevulinic acid synthetase activity. *Proc. Natl. Acad. Sci. U.S.A.* 67:1315.
3. Miyagi, K., R. Cardinal, I. Bossenmaier, and C. J. Watson. 1971. The serum porphobilinogen and hepatic porphobilinogen deaminase in normal and porphyric individuals. *J. Lab. Clin. Med.* 78:683.
4. Meyer, U. A., L. J. Strand, M. Doss, C. A. Rees, and H. S. Marver. 1972. Intermittent acute porphyria: demonstration of a genetic defect in porphobilinogen metabolism. *New Engl. J. Med.* 286:1277.

5. Strand, L. J., U. A. Meyer, B. F. Felscher, A. G. Redeker, and H. S. Marver. 1972. Decreased red cell uroporphyrinogen I synthetase in intermittent acute porphyria. *J. Clin. Invest.* 51:2530.
6. Sassa, S., S. Granick, D. R. Bickers, R. D. Levere, and A. Kappas. 1973. Studies on the inheritance of human erythrocyte δ -aminolevulinic acid dehydratase and uroporphyrinogen synthetase. *Enzyme (Basel)*. 16:326.
7. Sassa, S., S. Granick, D. R. Bickers, H. L. Bradlow, and A. Kappas. 1974. Studies in porphyria. III. A microassay for uroporphyrinogen I synthetase, one of three abnormal enzyme activities in acute intermittent porphyria, and its application to the study of the genetics of this disease. *Proc. Natl. Acad. Sci. U.S.A.* 71:732.
8. Kappas, A., H. L. Bradlow, P. N. Gillette, and T. F. Gallagher. 1972. Studies in porphyria. I. A defect in the reductive transformation of natural steroid hormones in the hereditary liver disease, acute intermittent porphyria. *J. Exp. Med.* 136:1043.
9. Kappas, A., H. L. Bradlow, P. N. Gillette, R. D. Levere, and T. F. Gallagher. 1972. A defect of steroid hormone metabolism in acute intermittent porphyria. *Fed. Proc.* 31:1293.
10. Bradlow, H. L., P. N. Gillette, T. F. Gallagher, and A. Kappas. 1973. Studies in Porphyria. II. Evidence for a deficiency of steroid Δ^4 -5 α -reductase activity in acute intermittent porphyria. *J. Exp. Med.* 138:754.
11. Lowry, O. H., N. J. Rosebrough, A. L. Farr, and R. J. Randall. 1951. Protein measurement with the Folin phenol reagent. *J. Biol. Chem.* 193:265.
12. Meyer, U. A. 1973. Intermittent acute porphyria. Clinical and biochemical studies of disordered heme biosynthesis. *Enzyme (Basel)*. 16:334.
13. Bogorad, L. 1958. The enzymatic synthesis of porphyrins from porphobilinogen. II. Uroporphyrin III. *J. Biol. Chem.* 233:510.
14. Levin, E. Y. 1968. Uroporphyrinogen III cosynthetase from mouse spleen. *Biochemistry*. 7:3781.
15. Sassa, S., S. Granick, and A. Kappas. 1975. Effect of lead and genetic factors on heme biosynthesis in the human red cell. *Ann. N. Y. Acad. Sci.* 244:419.
16. Sassa, S., R. D. Levere, G. Solish, and A. Kappas. 1974. Studies on the porphyrin-heme biosynthetic pathway in cultured human amniotic cells. *J. Clin. Invest.* 53:702.
17. Granick, S., P. Sinclair, S. Sassa, and G. Grieninger. 1975. Heme control on the synthesis of δ -aminolevulinic acid synthetase in chick embryo liver cells cultured in a defined medium. *J. Biol. Chem.* In press.
18. Bonkowsky, H. L., D. P. Tschudy, E. C. Weinbach, P. S. Ebert, and J. M. Doherty. 1975. Porphyrin synthesis and mitochondrial respiration in acute intermittent porphyria: studies using cultured human fibroblasts. *J. Lab. Clin. Med.* 85:93.
19. Sassa, S., J. L. Granick, S. Granick, A. Kappas, and R. D. Levere. 1973. Studies in lead poisoning. I. Analysis of blood protoporphyrin levels in the detection of chronic lead intoxication in the subclinical range. *Biochem. Med.* 8:135.
20. Nakao, K., O. Wada, T. Kitamura, K. Uono, and G. Urata. 1966. Activity of aminolaevulinic acid synthetase in normal and porphyric human livers. *Nature (Lond.)*. 210:838.