

Temperature Characteristics of Excitation in Space-Clamped Squid Axons

RITA GUTTMAN with the technical assistance of ROBERT BARNHILL

From the Laboratory of Biophysics, the National Institute of Neurological Diseases and Blindness, National Institutes of Health, Bethesda, Maryland, and the Department of Biology, Brooklyn College, Brooklyn, New York

ABSTRACT Temperature characteristics of excitability in the squid giant axon were measured for the space-clamped axon with the double sucrose gap technique. Threshold strength-duration curves were obtained for square wave current pulses from 10 μ sec to 10 msec and at temperatures from 5°C to 35°C. The threshold change of potential, at which an action potential separated from a subthreshold response, averaged 17 mv at 20°C with a Q_{10} of 1.15. The average threshold current density at rheobase was 12 μ a/cm² at 20°C with a Q_{10} of 2.35 compared to 2.3 obtained previously. At short times the threshold charge was $1.5 \cdot 10^{-8}$ coul/cm². This was relatively independent of temperature and occasionally showed a minimum in the temperature range. At intermediate times and all temperatures the threshold currents were less than for both the single time constant model and the two factor excitation process as developed by Hill. FitzHugh has made computer investigations of the effect of temperature on the excitation of the squid axon membrane as represented by the Hodgkin-Huxley equations. These are in general in good agreement with our experimental results.

INTRODUCTION

In 1962, the effect of temperature upon the threshold membrane voltage and current of squid giant axon was investigated (Guttman, 1962). A rise in the thresholds for membrane current and voltage was found with increasing temperature. It was somewhat disturbing that Sjodin and Mullins (1958) had found a decrease in the threshold on increasing temperature. Dr. Richard FitzHugh suggested that the seeming discrepancy between the work of Sjodin and Mullins and our 1962 work might be due to the fact that they had used short pulses and we had used long, rheobasic pulses. The experimental work has been continued both to resolve this difficulty and to give a basis for a comparison in this rather critical region with calculations based on the Hodgkin-Huxley equations.

Membrane excitation characteristics for the squid axon had been previ-

ously calculated at two temperatures and a few pulse durations on National Bureau of Standards computers by Cole et al. (1955) and confirmed at one temperature by FitzHugh and Antosiewicz (1959). FitzHugh (1966) has now investigated this problem in more detail, first using an analog and then a digital computer. These thresholds were computed for a space-clamped axon, assuming uniform membrane potential and current, rather than for the more complicated problem of the initiation of a propagating impulse. However, there are only a few experimental excitation data of any kind for the squid axon and almost none of these is for the space clamp situation.

Since all the preliminary calculations clearly indicated the importance of pulse duration in any study of the effect of temperature upon excitation, a more complete experimental study of strength-duration relationships has been made. The temperature characteristics of excitability of squid giant axon were investigated, utilizing the double sucrose gap technique for a space clamp. Strength-duration curves were established for square wave pulses ranging from 10 μ sec to 10 msec and at temperatures ranging from 5°C to 35°C. A brief historical account of the earlier work on temperature effects upon excitation and on the sucrose gap technique is given in the previous paper (Guttman, 1962).

MATERIAL AND METHODS

The giant nerve fiber of the hindmost stellar nerve of the squid, *Loligo pealii*, was used throughout. It was dissected out under running sea water, separated from neighboring smaller fibers under a binocular dissecting microscope, dipped in an isosmotic deionized sucrose solution (725 mM) for a few seconds, blotted on tissue, and then mounted in a Lucite chamber which was a modification of the one used in the earlier experiments.

The chamber (Fig. 1) was divided internally into five compartments by four partitions. The partitions were provided with aligned clefts for receiving the axon, which was sealed in each cleft by vaseline (cf. Whitcomb and Friess, 1960). The length of the central sea water compartment (Fig. 1C) was 0.8 mm, and the two sucrose compartments (B and D) were each 6.5 mm long. The extreme compartments (A and E), each 15 mm long, were filled with sea water containing 200 mM KCl, in order to give zero potential at the ends of the axon in these compartments (Curtis and Cole, 1942). All partitions were 3 mm thick. The solutions in the sea water and sucrose compartments were continuously circulated, flowing up from below, and being sucked off from above to maintain levels above the axon. The sucrose levels were maintained slightly higher than the sea water level to provide a higher hydrostatic pressure on the sucrose and thereby reduce the extent of the sucrose contamination by sea water.

The incoming sea water was used to control the temperature in the central compartment. It was first cooled nearly to freezing by flowing it through one tube of a stainless steel countercurrent heat exchanger as a 20% ethylene glycol solution at -15°C was pumped continuously through the other tube from a tank containing frozen blocks of the same solution. The sea water was then heated to the desired tem-

perature by a small heating coil as it passed into the axon chamber. The heating power was controlled by an error signal from the thermistor bridge (Cole, 1957) used to measure the sea water temperature.

The portion of the axon in the central compartment was surrounded by a semi-circular current electrode, P'' . This electrode filled the entire length of the central compartment. An approximately uniform current density in the neighborhood of the electrode was expected at least at rest because its length (0.8 mm) was considerably less than the "characteristic length" of about 6 mm found for squid axon (Cole and Hodgkin, 1939).

Square wave pulses were provided by a Tektronix 161 or 163 pulse generator at one pulse per second and applied to platinized platinum electrodes located in compartments A and C of a nerve chamber divided internally into five compart-

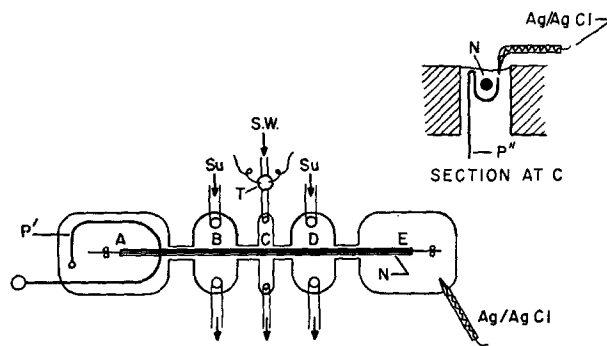

FIGURE 1. Mounting chamber used for studying temperature characteristics of excitation in space-clamped squid axons. Chamber is internally divided into five compartments, A , B , C , D , and E , by partitions provided with aligned clefts in which axon, N , rests. P' and P'' are platinized platinum electrodes for application of current. The Ag/AgCl electrodes are used for potential measurement. T , thermistor. For further details, consult text.

ments: A , B , C , D , and E . Current was indicated on the upper beam of a Tektronix model 502 dual beam cathode ray oscilloscope connected across a $1\text{ k}\Omega$ resistor in series with the active current lead. The membrane potentials were measured between the two Ag/AgCl electrodes in compartments C and E and recorded on the lower beam of the oscilloscope. Resting potentials were monitored by a dc millivoltmeter.

RESULTS AND DISCUSSION

Typical records obtained with rheobasic currents (upper picture) and short pulses (lower picture) are shown in Fig. 2. In each, the upper trace represents the square wave current pulse sent in, and the lower trace represents the membrane potential. The action potentials shown in Fig. 2 are about 90 mv, and they varied from 85 to 120 mv with the method described. In earlier

experiments, when the axon was not prerinsed in isosmotic sucrose, the action potentials were lower.

The records were obtained when a just subthreshold pulse was followed by a threshold pulse and the two records were superimposed in a double exposure. The point where the trace of the local subthreshold response deviated from the action potential was taken as a measure of threshold membrane voltage. The dip in the rheobasic current pulse reflects the change in the membrane resistance during activity. Since it appears later in the record than

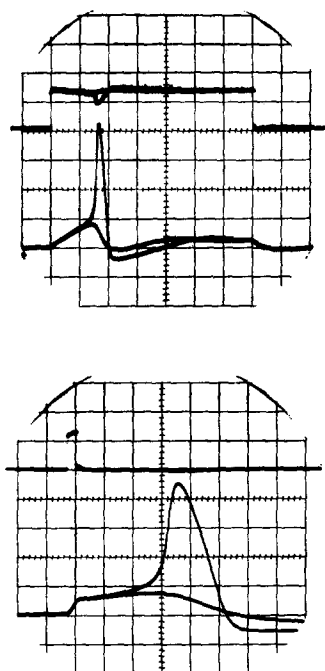

FIGURE 2. Typical records obtained when a rheobasic current of 7 msec (upper picture) and a 70 μ sec short pulse (lower picture) are used to study threshold membrane voltage. In each the upper trace represents the square wave pulse sent in, and the lower trace represents the records obtained when a just subthreshold pulse is followed by a threshold pulse and the two records are superimposed in a double exposure. The point where the trace of the local subthreshold response deviates from the action potential is used as a measure of threshold membrane voltage. Calibration per division in upper picture is 20 mv, 1 μ a, and 1 msec; in lower picture, 20 mv, 10 μ a, and 0.2 msec.

the point of deviation of action potential from local response, it does not affect the threshold membrane voltage estimate.

The preliminary rinse in isosmotic sucrose also reduced the measured threshold membrane current by a factor of several times.

Effect of Temperature upon Threshold Change of Membrane Voltage

Results obtained in a study of threshold change of membrane voltage on seven axons using short and rheobasic pulses are summarized in Fig. 3. As is seen in this figure, the threshold change in voltage for short pulses is about 12% higher than for rheobasic pulses.

At 20°C, the threshold at which an action potential separated from a subthreshold response averaged 17 mv for both short and rheobasic pulses with a Q_{10} of 1.15.

Hagiwara and Oomura (1958) found that the critical depolarization necessary for excitation is constant for all pulse durations, which is a good approximation.

Effect of Temperature upon Threshold Membrane Current and Time Constant

Typical results for the effect of temperature upon threshold membrane current at stimulating pulses of various durations are shown in Fig. 4, where the threshold current in microamperes is plotted against the pulse duration in

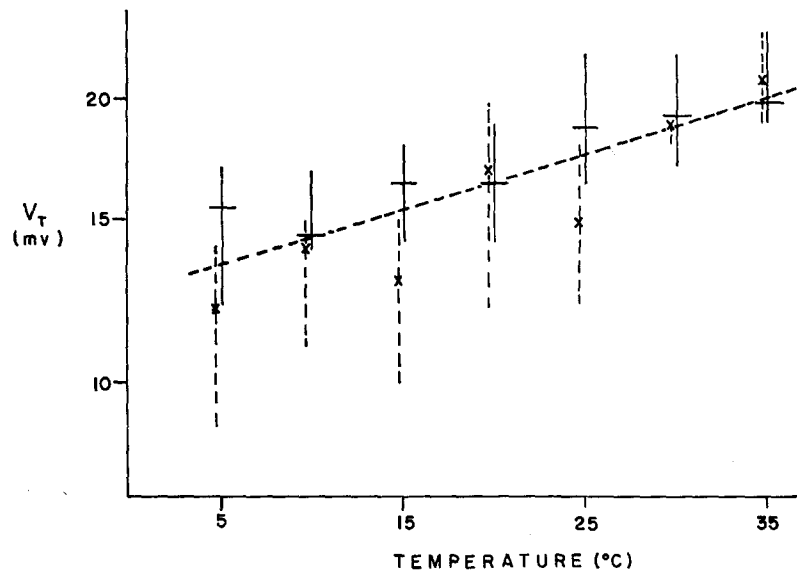

FIGURE 3. Temperature dependence of threshold change of membrane voltage when stimulating pulses of short duration: 20 μ sec, 50 μ sec, or 70 μ sec (means represented by short bars and range by unbroken lines at right for each temperature) and rheobasic pulses: 2, 5, or 7 msec (means represented by x's and range by broken lines at left for each temperature) are used. Threshold voltage V_t in millivolts is plotted on logarithmic scale against temperature in degrees Centigrade. Data from seven axons.

microseconds on logarithmic scales. Each run commenced and ended with a 70 μ sec pulse, and the small variation in threshold at the beginning and end of the runs indicates that conditions remained fairly constant during the course of the run. The reproducibility of runs upon a single axon is also discussed in a previous paper (Guttman, 1962, cf. Fig. 3). These runs were carried out at 5°C, 15°C, and 25°C on the same axon but usually data were taken near 5° intervals over the range, 5–35°C.

These data approach a constant current threshold, the rheobase I_o , at long durations as indicated by the horizontal lines. They approach the 45° lines, $It = Q$ a constant quantity, for the short pulse durations. These two lines

were adjusted to give a best fit to the points for each experiment at each temperature and so give values for I_0 and Q . It is seen that the rheobase threshold increases with increasing temperature while there is much less change in constant quantity for short stimuli.

In the single example shown in Fig. 5, the constant quantity showed a minimum at about 15°C. This was also found in other axons but not for all. In his theoretical paper, FitzHugh (1966) shows our averaged data and men-

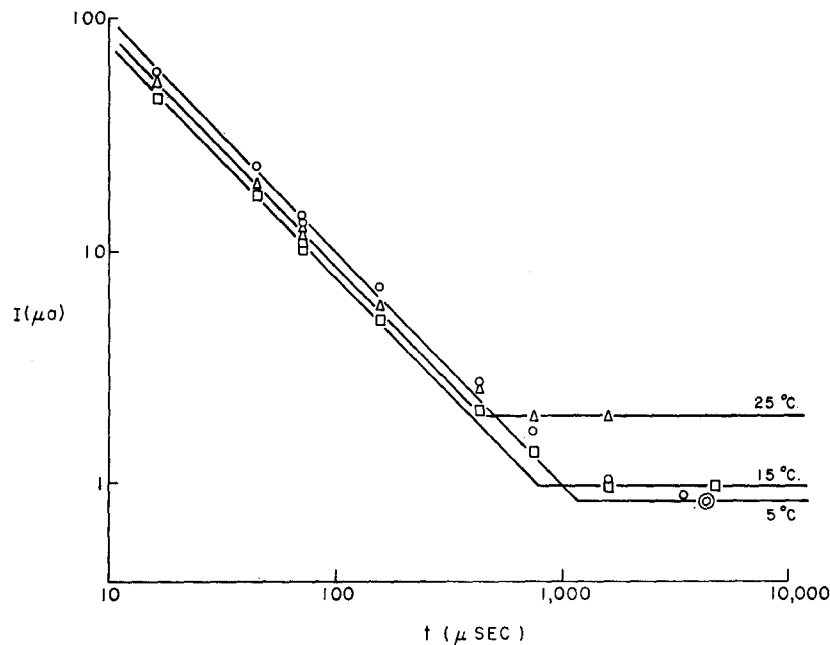

FIGURE 4. Temperature dependence of threshold membrane current when stimulating pulses of various durations are utilized. Intensity of the current in microamperes is plotted against duration in microseconds both on log scales. Runs were carried out at 5°C, 15°C, and 25°C on the same axon.

tions that he also finds that the curve goes through a minimum in the temperature range studied when threshold instantaneous shocks are investigated.

The intersection of Q and I_0 lines gives a time constant of the excitation process, $\tau = Q/I_0$. When the data are superposed to normalize them at τ , as in Fig. 6, it is found that they lie reasonably well on a single curve. This shows that the form of the strength-duration relation is not markedly dependent upon temperature. The time constants do, however, vary with temperature, as shown in Fig. 7 for four axons studied. The average $\tau = 1.2$ msec at 20°C with a $Q_{10} = 0.44$.

The form of the I vs. t relation is in essential agreement with the 1947

studies of Cole and Marmont (Cole, 1955). The temperature variation of the rheobase later obtained by them (personal communication) gave $Q_{10} = 2.0$ from 5°C to 25°C. In contrast, Tasaki (1949) found that in single motor fibers of the toad the rheobase did not vary with temperature.

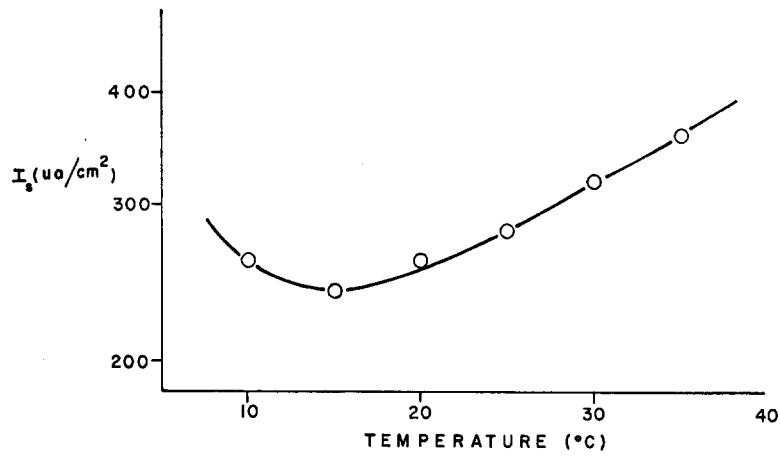

FIGURE 5. Effect of temperature upon threshold membrane current for pulses of short duration (50 μ sec). Current density in μ a/cm² plotted on logarithmic scale vs. temperature in degrees Centigrade. All points taken on same axon.

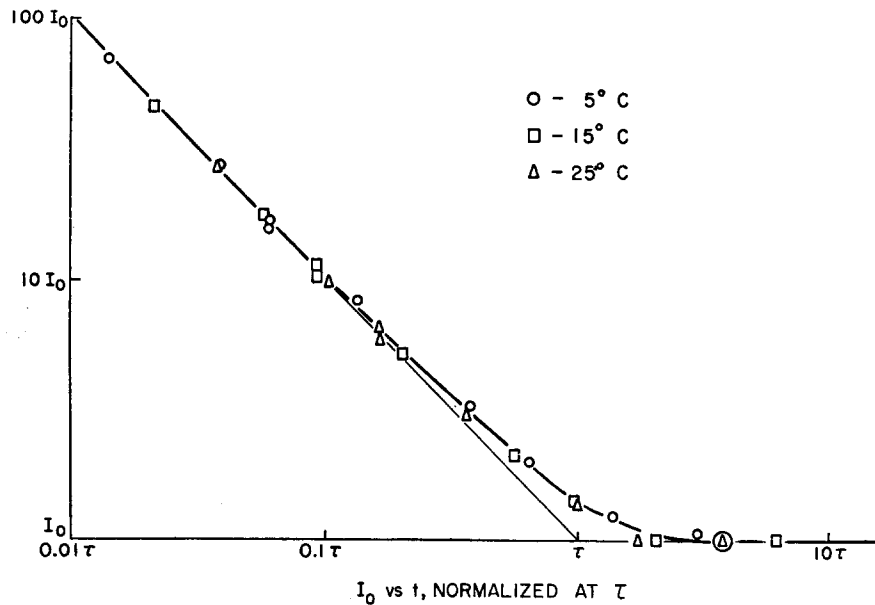

FIGURE 6. Same data as in Fig. 4, with curves normalized at τ , the time constant of excitation of the membrane.

Threshold Current Density

In order to obtain threshold current density values for rheobasic and short threshold current pulses, it is necessary to have measurements of the effective membrane area involved. It was hoped and expected that this would be the apparent area between the vaseline seals, about $1.25 \cdot 10^{-2}$ cm². However, for short and intermediate pulse durations the membrane capacity, calculated

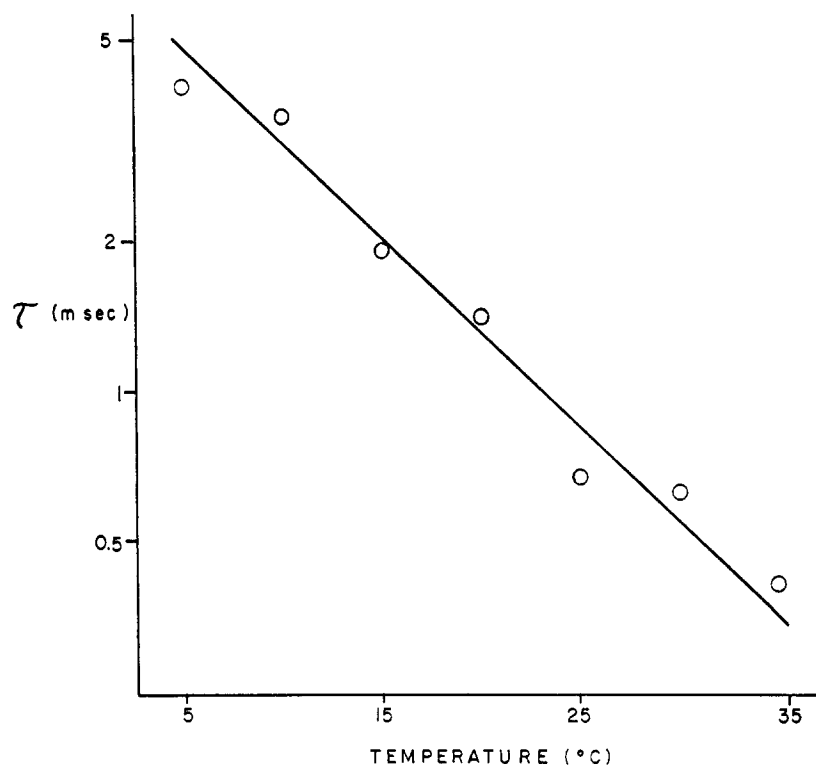

FIGURE 7. Temperature dependence of time constants of excitation in four axons. Average τ in milliseconds plotted logarithmically vs. temperature in degrees Centigrade.

from the figure for this area, varied from about $4 \mu\text{f}/\text{cm}^2$ in some experiments to nearly $8 \mu\text{f}/\text{cm}^2$ in others. But since other membrane capacity measurements lie mostly in the range of 0.8 to $1.2 \mu\text{f}/\text{cm}^2$ (Curtis and Cole, 1938; Cole and Marmont (unpublished); Hodgkin, Huxley, and Katz, 1952), it seemed more reasonable to assume a nominal value of $1.0 \mu\text{f}/\text{cm}^2$ and to calculate an effective membrane area which would include at least an approximate correction for a leakage of sea water under the vaseline. The capacitance of the effective area can be calculated from the expression:

$$C = I\Delta t/\Delta V$$

where I is the stimulating current, ΔV can be obtained from the photographic records (cf. Fig. 2), and Δt is the corresponding duration. The effective area in cm^2 can then be estimated as equal to the calculated capacitance divided by $1 \mu\text{f}/\text{cm}^2$.

When this method was used, the effective areas were generally smaller for the short than for the long pulses and there was some tendency for them to be smaller at the higher temperatures. The effect of pulse duration is to be ex-

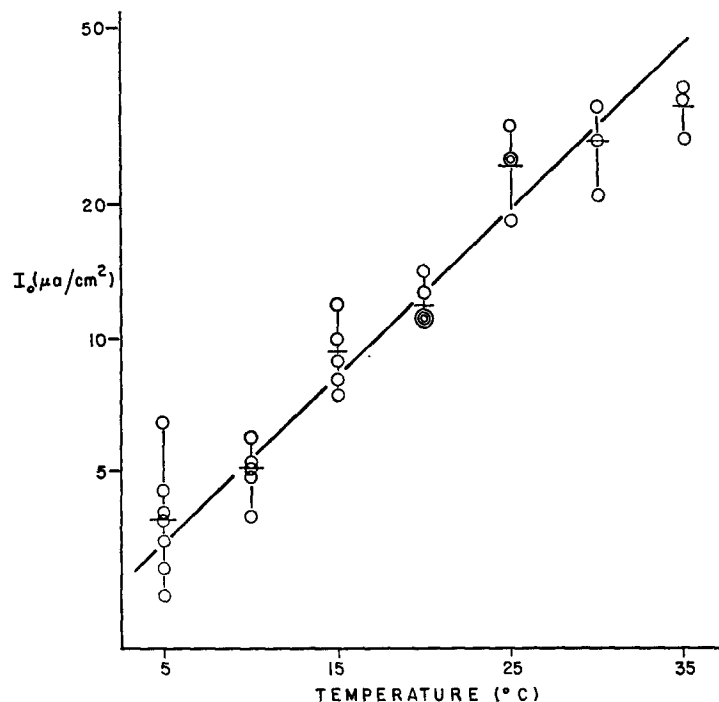

FIGURE 8. Temperature dependence of rheobasic pulses. I_0 in $\mu\text{a}/\text{cm}^2$ plotted on logarithmic scale vs. temperature in degrees Centigrade. Means indicated by horizontal bars.

pected because the capacitive current reduces the characteristic length below the steady-state value under the vaseline. A ready explanation for a temperature effect has not been found.

In spite of these uncertainties and the disadvantages of the sucrose and vaseline experimental technique, no logical basis has been found to dismiss the effective area as it has been calculated from a fixed capacity and the initial linear rates of rise of the membrane potential. So it has been used in estimating all the absolute values presented (Figs. 5 to 8). Subsequent experiments utilizing the same set-up, in which changing the chemical composition of the external bathing solution was accompanied by rapid changes in the electrical characteristics of the axon, support the view that the solution in contact with

the axon under the seals was changed quite rapidly. Probably not much current was able to penetrate to the region where the solution was changing slowly and where potassium ions might be leaking out of the axon and being trapped.

The average threshold charge is $1.5 \cdot 10^{-8}$ coul/cm² with no over-all significant change with temperature. However, three axons did show minima within the temperature range as shown for one axon in Fig. 5, as was mentioned above.

The rheobasic currents show some fluctuation from one axon to another but here again a logarithmic change of rheobasic current with temperature was found to be a good expression of the individual as well as the collective data (Fig. 8). The mean current density at rheobase was $12 \mu\text{a}/\text{cm}^2$ at 20°C with a Q_{10} of 2.35, rather well confirming the earlier less certain Q_{10} value of 2.3 (Guttman, 1962).

These values are to be compared with those of Cole and Marmont at 26°C to 29°C (Bonhoeffer, 1953) which give $I_o = 21 \mu\text{a}/\text{cm}^2$ at 20°C while the constant quantity is $Q_o = 2.1 \cdot 10^{-8}$ coul/cm². Their subsequent unpublished rheobase data were interpolated to give a mean value of $41 \mu\text{a}/\text{cm}^2$ at 20°C. Such large variations suggest that the rheobase may be a parameter which is quite sensitive to conditions that are difficult to control. The experiments may not be comparable because the two early ones were made with internal axial electrodes but different equipment while the present axons were probably hyperpolarized near the sucrose gaps (Julian, Moore, and Goldman, 1962; Blaustein and Goldman, 1965).

Effect of Temperature upon Other Characteristics

We found as did Hodgkin and Katz (1949) that there was very little effect of temperature upon resting potential until about 25°C was reached, above which temperature there was a slight decrease in resting potential as the temperature was increased. The marked decrease in action potential spike height with increase in temperature found by Hodgkin and Katz was also confirmed, as was the spreading out of the action potential in time as the fiber was cooled. An increased tendency toward repetitive firing was evident when the temperature was increased.

Comparisons with Theory

All the useful expressions for the strength-duration threshold relations agree with a rheobase and a constant quantity but vary in the abruptness of the transition region between these two extremes. An index of this transition, as used by FitzHugh (1966), is the threshold at $t = \tau$ as compared to the rheobase, $\sigma = I(\tau)/I_o$. For the time-honored Weiss law

$$I/I_o = 1 + \tau/t$$

$\sigma = 2.0$ which is much larger than most recent data. The next expression, for a model with a single time constant (Blair, 1932), is of the form:

$$I = I_0/[1 - \exp(-t/\tau)]$$

This gives $\sigma = 1.582$ which is considerably above the first squid axon results as shown by Cole (1955), $\sigma = 1.26$, and the present, $\sigma = 1.38$. The general two factor model of Young (1937) gives values of σ lying between 1.188 and 1.582 (FitzHugh, 1966). For the case of an overdamped potential response to a subthreshold stimulus, the limits are 1.445 to 1.582. For an underdamped response (which the Hodgkin-Huxley model has), the lower limit is 1.188. The upper limit is 1.445 if the accommodation is complete, as in the model of Hill (1939; also Katz, 1939), or 1.582 if incomplete. An interpolation of the first calculations of the Hodgkin-Huxley equations (Cole et al., 1955) gave $\sigma = 1.35$. FitzHugh (1966) finds that in the HH equations σ varies with temperature, decreasing from 1.344 to 1.316 as the temperature is increased from 0°C to 20°C. Thus the form of the strength-duration relation given by experiment is a confirmation of the HH (1952) equations as expressions of the properties of the squid axon. Similarly the time constant τ and its variation with temperature are in reasonable accord with the calculations (Cole et al., 1955; FitzHugh, 1966). While the absolute value of Q is somewhat high, that for I_0 agrees quite well with the value calculated by the HH formulation.

CONCLUSIONS

The results of experiment and analysis show that the squid axon under sucrose space clamp has a constant quantity threshold for short stimuli and that this is relatively independent of temperature. The rheobase threshold for long duration constant currents increases rapidly with temperature, more than twofold for 10°. The threshold currents of intermediate duration are less than for both the single and the two factor exponential expression for excitation as developed by Blair and Hill. These characteristics are in agreement with the 1947 space-clamped excitation data of Cole and Marmont (Bonhoeffer, 1953; Cole, 1955) and with the first calculations of the Hodgkin-Huxley equations.

However, when the apparent membrane area is used the present experiments do not confirm the early values for the threshold charge and current or for the membrane capacity. The measured capacity may be used to estimate an effective axon length extending more than a millimeter under the vaseline barriers. Then a threshold charge of about $1.5 \cdot 10^{-8}$ coul/cm² and a current density at rheobase at 20°C of about 12 μ a/cm² are obtained. The corresponding values computed for the unmodified HH equations are $0.69 \cdot 10^{-8}$ coul/cm² and 5.6 μ a/cm². Using the calculated value for effective mem-

brane area, the time constant for excitation was found to be about 1.2 msec at 20°C.

In general, except for a somewhat high threshold charge, the experimental results are in good agreement with FitzHugh's (1966) computer investigations of the effect of temperature on the excitation of the squid axon membrane as represented by the Hodgkin-Huxley equations.

It is a pleasure to acknowledge the assistance of Mr. Leonard Binstock, and others of the staff and especially the suggestions and discussions by Dr. Kenneth S. Cole, all of the Laboratory of Biophysics, National Institute of Neurological Disease and Blindness, National Institutes of Health.

This work was carried out at the Marine Biological Laboratory, Woods Hole, Massachusetts, and was aided by National Science Foundation Grant GS 1463.

Received for publication 9 September 1965.

REFERENCES

- BLAIR, H. A., 1932, *J. Gen. Physiol.*, **15**, 709.
- BLAUSTEIN, M. P., and GOLDMAN, D. E., 1965, *9th Ann. Meeting Biophysic. Soc.*, abstracts, WB 4, 13.
- BONHOEFFER, K. F., 1953, *Naturwissenschaften*, **40**, 301.
- COLE, K. S., 1955, Ions, potentials, and the nerve impulse, in *Electrochemistry in Biology and Medicine*, (T. Shedlovsky, editor), New York, John Wiley and Sons, 128, 136.
- COLE, K. S., 1957, *Rev. Scient. Instr.*, **28**, 326.
- COLE, K. S., ANTOSIEWICZ, H. A., and RABINOWITZ, P., 1955, *J. Soc. Ind. and Appl. Math.*, **3**, 153.
- COLE, K. S., and HODGKIN, A. L., 1939, *J. Gen. Physiol.*, **22**, 671.
- COLE, K. S., and MARMONT, G., unpublished data.
- CURTIS, H. J., and COLE, K. S., 1938, *J. Gen. Physiol.*, **21**, 757.
- CURTIS, H. J., and COLE, K. S., 1942, *J. Cell. and Comp. Physiol.*, **19**, 135.
- FITZHUGH, R., 1966, *J. Gen. Physiol.*, **46**, 989.
- FITZHUGH, R., and ANTOSIEWICZ, H. A., 1959, *J. Soc. Ind. and Appl. Math.*, **7**, 447.
- GUTTMAN, R., 1962, *J. Gen. Physiol.*, **46**, 257.
- HAGIWARA, S., and OOMURA, Y., 1958, *Japan. J. Physiol.*, **8**, 234.
- HILL, A. V., 1939, *Proc. Roy. Soc. London, Series B*, **119**, 305.
- HODGKIN, A. L., and HUXLEY, A. F., 1952, *J. Physiol.*, **117**, 500.
- HODGKIN, A. L., HUXLEY, A. F., and KATZ, B., 1952, *J. Physiol.*, **116**, 424.
- HODGKIN, A. L., and KATZ, B., 1949, *J. Physiol.*, **109**, 240.
- JULIAN, F. J., MOORE, J. W., and GOLDMAN, D. E., 1962, *J. Gen. Physiol.*, **45**, 1195.
- KATZ, B., 1939, *Electric Excitation of Nerve*, London, Oxford University Press.
- SJODIN, R. A., and MULLINS, L. J., 1958, *J. Gen. Physiol.*, **42**, 39.
- TASAKI, I., 1949, *Biochim. et Biophysica Acta*, **3**, 498.
- WHITCOMB, E. R., and FRIESS, S. L., 1960, *Arch. Biochem. and Biophysics*, **90**, 260.
- YOUNG, G., 1937, *Psychometrika*, **2**, 103.