

Avoidance Response, House Response, and Wind Responses of the Sporangiphore of *Phycomyces*

R. J. COHEN, Y. N. JAN, J. MATRICON, and M. DELBRÜCK

From the Division of Biology, California Institute of Technology, Pasadena, California 91125. Dr. Cohen's present address is the Department of Biochemistry, College of Medicine, University of Florida, Gainesville, Florida 32610. Dr. Matricon's present address is the Groupe de Physique des Solides, Université Paris VII, Paris, France.

ABSTRACT *Avoidance Response:* An object placed 1 mm from the growing zone of a *Phycomyces* sporangiphore elicits a tropic response away from the object. The dependence of this response on the size of the object and its distance from the specimen is described, as well as measurements which exclude electric fields, electromagnetic radiation, temperature, and humidity as avoidance-mediating signals. This response is independent of the composition and surface properties of the object and of ambient light. *House Response:* A house of 0.5- to 10-cm diameter put over a sporangiphore elicits a transient growth response. Avoidance responses inside closed houses are slightly smaller than those in the open. *Wind Responses:* A transverse wind elicits a tropic response into the wind, increasing with wind speed. A longitudinal wind, up or down, elicits a transient *negative* growth response to a *step-up* in wind speed, and vice versa. It is proposed that all of the effects listed involve wind sensing. This proposal is supported by measurements of aerodynamic effects of barriers and houses on random winds. The wind sensing is discussed in terms of the hypothesis that a gas is emitted by the growing zone (not water or any normal constituent of air), the concentration of which is modified by the winds and monitored by a chemical sensor. This model puts severe constraints on the physical properties of the gas.

INTRODUCTION

When an object is placed about 1 mm from the growing zone of a sporangiphore of *Phycomyces* growing in air, in about 2 min the sporangiphore starts to bend away at about 2°/min for as long as half an hour or more. At no time during this response is any contact made with the object. This behavior has been called the avoidance response. The main purpose of this paper is to answer the question: How does the sporangiphore detect the nearby object?

The avoidance response was first described by Elfving in 1881 and extensively studied by him and by Steyer, Errera, Jost, Slotte, and others (reviewed by Elfving [1917]). It was rediscovered by Shropshire (1962) and studied

during summer workshops at the Cold Spring Harbor Laboratory, 1965–1968. Through these studies, many facts about this response were established and summarized in 1969 in a general review of *Phycomyces* (Bergman et al., 1969) as follows:

(a) If the sporangiophore is placed between two closely opposed barriers or inside a tube with internal diameter of a few millimeters it shows a transient positive growth response. (b) The avoidance response occurs in complete darkness. (c) It occurs at 100% humidity. (d) Neither the material nor the color of the barrier have a strong influence on the response: glass, wood, plastic, black tape, or a crystal transparent for infrared radiation of a black body at room temperature are equally effective. (e) The solid barrier can be replaced by a glass rod (diameter, 150 μm), by a horizontal human hair (diameter, 75 μm), or by a horizontal silk thread (diameter, 15 μm). In the experiments with horizontal cylindrical objects, the latency is independent of the diameter of the object, but the thinner the object the closer it has to be placed and the more localized is the response. Heating a horizontal copper wire anywhere between 0.1°C and several °C does not modify the effect.

These observations excluded visible light or ultraviolet radiation as the stimulus for the avoidance response. Beyond this, however, nothing conclusive could be said about the mechanism underlying it. For example, although qualitatively the sporangiophore avoided barriers of various colors or materials placed at the same distance from the sporangiophore, it was not shown in those experiments whether these barriers are quantitatively equally effective in causing the response. Therefore, these data leave open the question whether infrared radiation or electrostatic forces, for instance, might play an important role.

The above-mentioned experiments suggested, among numerous others, the following hypothesis (Bergman et al., 1969):

A volatile growth effector is emitted by the organism. The barrier causes a concentration gradient across the sporangiophore. This gradient is sensed and causes the differential growth rate. Bilateral barriers result in symmetric changes in concentration, and hence cause a transient growth response.

This hypothesis will be referred to as the chemical self-guidance hypothesis. In recent years this hypothesis has dominated the research on the avoidance response and most of the efforts have centered on testing and modifying it.

Since 1968, the study of the avoidance response was continued independently by D. L. Johnson and R. I. Gamow at the University of Colorado, and by the present authors at the California Institute of Technology.

Bergman et al. (1969) and Ortega and Gamow (1970) found that when a stage 4 sporangiophore is placed between a double barrier it undergoes a transient growth response. This growth response was called by Ortega and

Gamow the "avoidance growth response." This observation suggests that the bending away from a single barrier results from an increase in growth on the side nearer the barrier, not a decrease in growth on the further side (Johnson and Gamow, 1971). This avoidance growth response may have the same origin as the house growth response discovered by us. Johnson and Gamow (1971) explain the avoidance growth response by the increase of humidity around the sporangiophore as a result of the double barrier. However, the striking finding reported by us is that the house growth response is rather insensitive to the size of the house. Therefore, if we want to explain these two responses by the same mechanism we have to abandon Johnson and Gamow's explanation.

Johnson and Gamow (1971) also reported that the response is independent of the orientation in relation to gravity, that it does not occur in still air, and that its manifestation requires both the movement of air and a barrier. They proposed that a growth-stimulating gas is emitted from the sporangiophore and that the movement of air and the presence of the barrier results in a region of relative stagnation in the region between the barrier and the sporangiophore in contrast to the faster air movement in the region between the sporangiophore and the environment. They suggested water vapor as the effector gas. These authors were the first to recognize the importance of random air currents. We show that water vapor cannot be the gas in question and adduce circumstantial evidence for a new feature: the capacity of the sporangiophore to adapt to a wide range of air movements, down to exceedingly small ones, gradients of which it can still detect.

GENERAL METHODS

(I) *Culture Conditions*

Sporangiophores of wild type *Phycomyces* strain NRRL 1555(–) were grown in shell vials (12-mm diameter x 35-mm height) containing 4% potato dextrose agar (Difco) and 5 $\mu\text{g}/\text{ml}$ thiamine (Sigma Chemical Co., St. Louis, Mo.). An average of five heat-shocked spores were inoculated into each vial. The vials were incubated enclosed in glass jars at $22 \pm 1^\circ\text{C}$ with overhead diffuse white light of intensity about $10 \mu\text{W}/\text{cm}^2$ until the first crop of sporangiophores appeared. The vials were then removed from the jars and incubated in a light box at $22 \pm 1^\circ\text{C}$ with overhead illumination (a few microwatts per square centimeter). The box was humidified to 60–80%. Usually only the second, third, and fourth crops of 2- to 3-cm long stage 4b sporangiophores were used for the experiments.

(II) *Physiological Experiments*

At least 30 min before each experiment, a vial was selected and transferred to the experimental setup to adapt to the new environment and to reach a steady state of growth. For growth measurement, the position of the top of the sporangium was measured to $\pm 2 \mu\text{m}$ using a measuring microscope fitted with a Filar micrometer

(Gaertner Science Corp., Chicago, Ill.). The angular deviation of the sporangiophore from the vertical was measured using a goniometer accurate to $\pm 0.5^\circ$. A Sony Videorecorder model PV 120 U modified for time lapse (1:60) recording proved convenient for experiments where only the bending of the sporangiophores is of interest. All the experiments were carried out between 21 and 25°C either under overhead diffuse white light of intensity about $10 \mu\text{W}/\text{cm}^2$ or in the darkroom illuminated with physiologically inactive red light.

(III) Apparatus for the Avoidance Response

The design is shown in Fig. 1. The basic idea of the design is to allow fine movement of the sporangiophore and of the barriers while keeping the chamber fixed and airtight.

The chamber is made of transparent Lucite and the sporangiophore stands in the middle of it. The vertical position is adjusted by the micrometer screw A. The horizontal positions of two parallel barrier mountings are independently controlled by micrometer screws B and C. Barriers made of different materials are attached to the barrier mountings. Unless otherwise stated, the barriers are 2.2 x 2.2-cm Lucite or cover glass. The standard size of the chamber is a cube of 6.2 cm. Chambers of similar design but different size have also been used.

(IV) Apparatus for Wind Experiments

Unless otherwise stated, pumped room air (diaphragm pump downstream from the specimen) was used as air current source, with Tygon and glass tubings to conduct the air stream. The air flow rates were measured by calibrated flowmeters (Matheson #R615B and R615A, Matheson Co., Inc., East Rutherford, N. J.). Observation wind tunnels were made of glass constructed so as to ensure laminar flow of the air stream. Humidity was regulated by directing the air stream through various salt solutions.

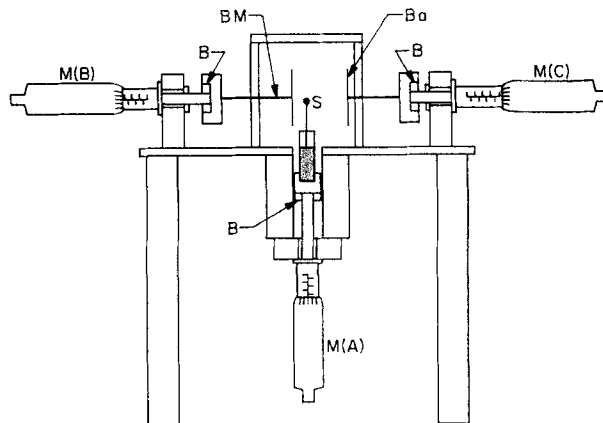

FIGURE 1. Standard apparatus for avoidance response experiments. The apparatus is made of Lucite. Legend: B, bearing; Ba, barrier, BM, barrier mounting; M, micrometer; S, sporangiophore. The closed chamber is a cube of 6.5-cm edge.

(V) *Measurement of Air Movements*

Velocities between a few millimeters per second and 150 cm/s can be estimated by timing the gross motion of cigarette smoke. For lower velocities, the velocities of individual microscopic smoke particles were determined by measuring the time for the particles to cross a laser beam about 1 mm in diameter. The laser (HeNe, Spectra Physics, operated at the physiologically inactive wavelength 632.8 nm) has an output power (0.5 mW) too low to induce convection by heating while being bright enough to allow the smoke particles to be seen. The velocity of the smoke particles falling under gravity is insignificant. This velocity was determined by timing the particle movement near a horizontal barrier within a closed house. The vertical component of air convection near a horizontal barrier is negligible. The free-fall velocity was found to be at most a few micrometers per second.

RESULTS

(I) *Wind Effects*

(A) WIND GROWTH RESPONSE Deliberately applied air currents of low speed cause a transient negative growth response of the sporangiphore. In the experiments, laminar room air currents (10–15 cm/s, generated by a pump) pass the sporangiphore either transversely, or longitudinally from above, or longitudinally from below. In each case there is a transient negative growth response after the air current is turned on and a transient positive growth response after the air current is turned off. Fig. 2 shows a typical

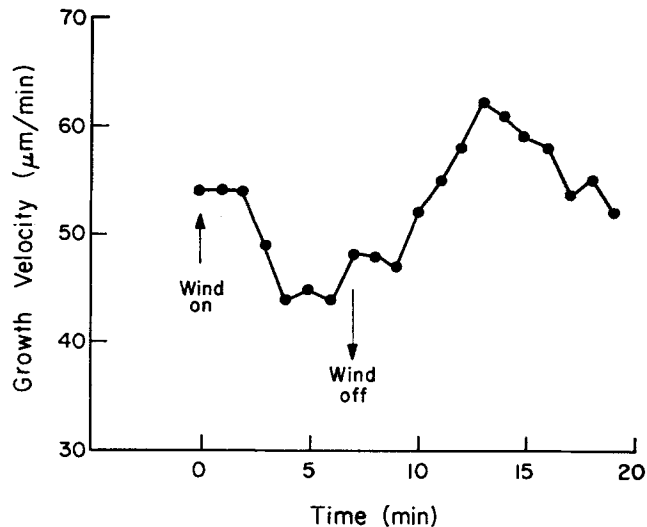

FIGURE 2. Wind growth response. The experimental setup is shown in Fig. 4. The transverse air current (3 cm/s) was turned on and off periodically, 7 min on, 12 min off, for a total of five periods (95 min). The average is plotted.

growth response to a transverse air current. In the case of the lateral wind the sporangiophore simultaneously shows a tropic response. The wind is turned on for only 7 min in each cycle. The total bending is only 5–6° with negligible effects on the measurement of the growth rate in the vertical direction. The sporangiophore tends to straighten itself during the period when the wind is off.

The wind growth response is substantial at a speed as low as 3 cm/s, as shown in Fig. 2. The effect diminishes when we decrease the wind speed down to 0.3 cm/s, which is comparable to the residual random wind velocity inside the wind tunnel. We conclude that a step-up of wind velocity, in any direction, from a few millimeters per second to a few centimeters per second is sufficient to elicit a significant negative growth response.

The nature of the air current can make a difference. With compressed air from the tap, the wind effect is either opposite in sign or absent. The compressed air probably differs in chemical composition from the room air to which the sporangiophore is adapted. One of us (R. J. C.) has tested a great number of volatile substances and has found that many produce negative and a few positive growth responses, some at very low concentrations of the agent.

RHEOTROPIC RESPONSE Fig. 3 shows the experimental setup and a typical tropic response. About 2 min after the air current is turned on, the sporangiophore starts to bend into the air current at a rate of 1°/min. The bending lasts for 30 min or more.

The bending rate as a function of air current velocity (or Reynold's number Re) is shown in Fig. 4. Up to $Re \cong 0.6$ the bending rate increases more or less linearly, then much more slowly. The tropic response virtually disappears at velocities ≤ 1 cm/s ($Re = 0.07$).

To interpret the rheotropic response, we begin with general remarks on the aerodynamic situations involved. Reynold's number, $Re = ul/\nu$ (u = velocity of air stream, l = characteristic dimension of the object, ν = kinematic viscosity), is a measure of the ratio of inertial forces to viscous forces. Attention will be focused on the sporangiophore-growing zone which can be considered as a long cylinder with a diameter of 0.01 cm. The kinematic viscosity of air at 20°C is 0.15 cm²/s. The Reynold's numbers for the air stream velocities used range from 0.07 to 10. Very large Reynold's numbers (> 100) imply turbulence; between 5 and 100 there is a wake. Below 5 there is laminar flow (Taneda, 1955; Van Dyke, 1964). For the sporangiophore-growing zone $Re = 5$ corresponds to a velocity of 75 cm/s; thus, at velocities below 75 cm/s, flow will be essentially laminar and symmetric in speed between the leeward and the windward sides. The tropic response demonstrates that the *direction* of the wind is detected in spite of this sym-

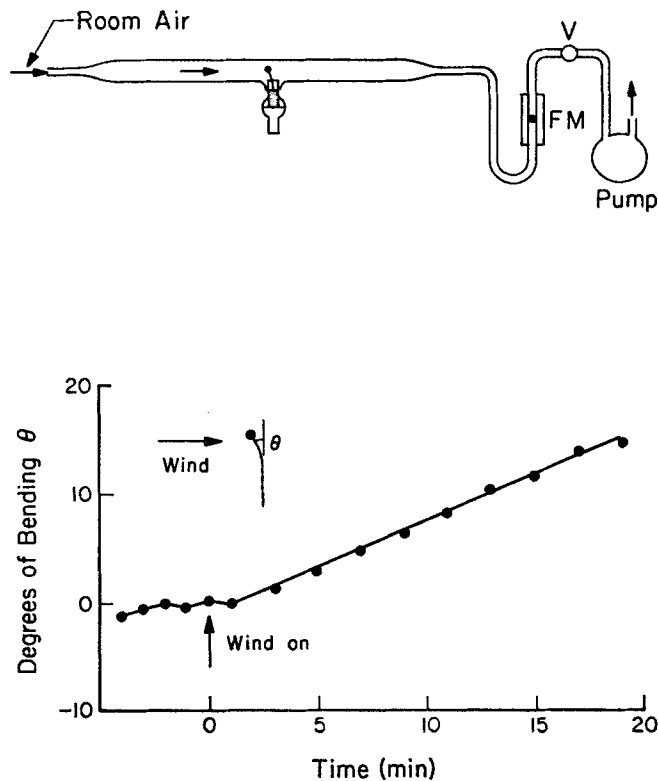

FIGURE 3. Rheotropic response. Top: the experimental setup. The wind tunnel is 2.5 cm square and 35 cm long. Room air is sucked through the wind tunnel by the pump, with the air speed controlled by the valve. Bottom: data from a typical experiment. Legend: FM, flowmeter; V, valve.

metry. This finding must be accounted for by the specific form of the chemical self-guidance hypothesis. As the velocity increases a wake develops. At the highest velocity (150 cm/s) tested in these experiments, there should be a significant wake but still no turbulence. The wake implies an asymmetry of the gradient of the tangential velocity between the two sides of a sporangiphore, increasing with increasing velocity. The slow increase in the bending rate at the higher velocities may be related to this asymmetry.

The stage 4b sporangiphores are known to exhibit growth responses to mechanical stretch above a certain threshold (Dennison and Roth, 1967). Therefore, wind effects might be suspected to be mediated indirectly, through the drag forces exerted by the wind. However, this conjecture can be rejected based on calculations (Jan, 1974) which show that the drag force caused by wind below 100 cm/s is too small to cause a stretch response.

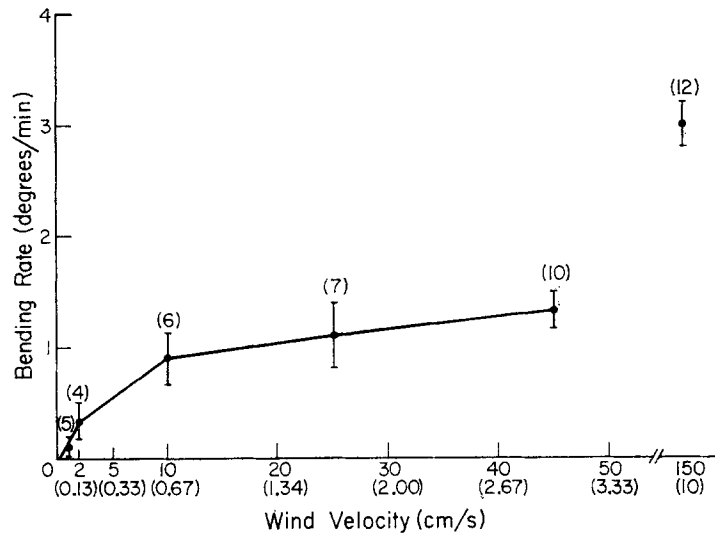

FIGURE 4. Bending into a transverse wind. The rate of bending increases with increasing transverse wind velocity. The number above each data point indicates the number of sporangiophores used. Error bars indicate standard deviations of the means. On the abscissa are wind velocities and the corresponding Reynold's numbers (Re).

(II) *Elimination of the Avoidance Response by an Air Stream Parallel to the Sporangiophore and to the Barrier*

Do wind effects mediate the avoidance response? If they do, we would expect air currents to interfere with the avoidance response. An experiment to test this possibility is shown in Fig. 5. From the open end of a vertical wind tunnel a laminar downward (or upward) air current of a speed of 15–30 cm/s passes the sporangiophore. The sporangiophore is adapted to the air current for at least 30 min. At $t = 0$, a glass barrier (2.2×2.2 cm) is positioned 1.2 mm away from the sporangiophore. The sporangiophore does not avoid the barrier as long as the air current persists. When the air current is turned off, the sporangiophore starts to avoid with a latency of 2–3 min. This experiment demonstrates that longitudinal air currents can interfere with the avoidance response. The fact that avoidance begins 2–3 min after stopping the wind shows that the specimen adapts rapidly to low wind velocities, very much in contrast to the slower dark adaptation of the *Phycomyces* sporangiophore (Bergman et al., 1969, section 14).

(III) *Characterization of the Avoidance Response*

(A) AVOIDANCE RESPONSE IN A CLOSED CHAMBER The speed of random air movements in a normal laboratory is in the range of 10–100 cm/s. We know from the study of the wind effects that air movements of this magnitude can introduce uncontrolled growth as well as rheotropic responses. The ve-

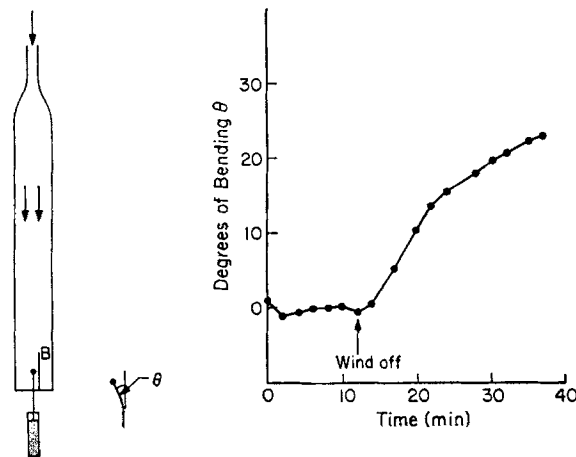

FIGURE 5. Elimination of the avoidance response by an air stream parallel to the barrier and the sporangiophore. The experimental procedure is described in the text. Tap air blown downward and room air sucked upward gave similar results. The wind tunnel is 2.5 cm square and 35 cm long.

locity of the air movement within a house is a function of time as well as space. After a house is closed, within a minute, the air movements inside the house quiet down, and a slow quasi-steady-state convection is established. The air movement pattern varies slowly with a time constant of a few minutes, presumably due to slight temperature differences between different wall areas.¹ Although the direction of the air velocity near a sporangiophore may vary, the magnitudes are more or less constant for a given house. Thus, the “quietness” for each house can be characterized by its “characteristic air speed” defined as the average speed of air movements near the sporangiophore inside that house. This characteristic air speed decreases with decreasing house size. Inside the standard avoidance apparatus (6.2 mm cube), the characteristic air speed is a few millimeters per second.

Fig. 6 shows a typical avoidance response of the sporangiophore to a barrier in the standard avoidance apparatus. The two barriers are initially far away (> 15 mm). At $t = 0$, one barrier is moved to a distance of 1.2 mm from the sporangiophore. After a latency of about 2 min, the sporangiophore starts to bend away for as long as 20 min or more.

The maximal bending rate occurs between the 4th and the 14th min and is

¹ The sporangiophore metabolizes at a high rate and transpires water into the air. As a consequence its temperature must be different from that of the environment and a microcirculation in the vicinity of the growing zone must thereby be generated. However, both calculations and direct measurements indicate that the temperature differences generated are less than 0.3°C, and calculation shows that such small temperature differences can only give microcirculation with velocities less than 0.08 mm/s. Direct observation has shown no measurable self-generated microcirculation. It must be considerably smaller than 0.08 mm/s.

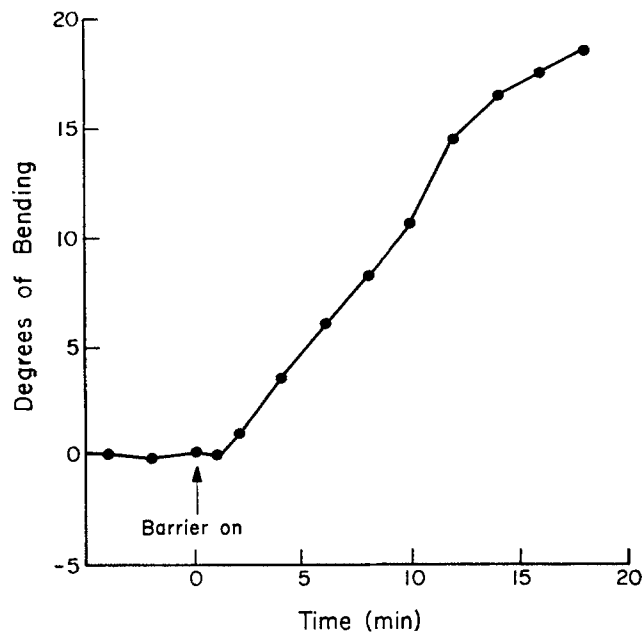

FIGURE 6. Avoidance response in a closed chamber. Inside the airtight standard avoidance apparatus, a square glass barrier (2.2 cm) is positioned 1.2 mm from the sporangiophore at the time indicated by the arrow. The sporangiophore bends away from the barrier after a latency of 1-2 min.

quite constant during this period. This rate can be used to characterize any particular avoidance response. In the example shown in Fig. 6, $(d\theta/dt)_{\max} = 1.3^\circ/\text{min}$.

(B) COMPARISON OF BARRIER MATERIALS

(a) *Unilateral Stimuli* The experiments were done in a sealed house under standard conditions, except for the material of the barrier. In the case of liquid barriers, the entire apparatus was tilted 90° , a beaker was filled with the specified liquid and the liquid meniscus served as the barrier. The meniscus was raised to the vicinity of a horizontal sporangiophore.

The sporangiophore also exhibits a negative geotropic response. This response does not interfere with the avoidance tests since the latency of geotropism is longer than 30 min, so that the avoidance response will be over before geotropism gets started. The independence of the two effects is brought out by the fact that the avoidance response is independent of the orientation of the sporangiophore and the barrier with respect to gravity, i.e. the avoidance response is similar whether the sporangiophore and the barrier are both vertically or both horizontally oriented (Johnson and Gamow, 1971, and confirmed by us). The barriers tried were all similarly effective in causing an

avoidance response, i.e. in the sealed house, any barrier (diameter > 10 mm) placed 1 mm away from the sporangiphore causes the sporangiphore to bend away at a rate 1–3°/min for about 20 min and with a latency of 2–4 min.

The different materials used include (a) solids: glass, quartz, plastic, Teflon, wood, black tape, aluminum, brass, ferromagnet, a crystal transparent for infrared radiation of a black body at room temperature, activated charcoal, and CaCl₂ and KOH pellets, and (b) liquids: water, concentrated sulfuric acid, paraffin oil, and FC-43 (a fluorocarbon oil, perfluorotributylamine). Collectively they cover extreme ranges of the following parameters: light absorption (visible, ultraviolet, infrared), dielectric properties, magnetic properties, surface adsorption properties (activated charcoal, CaCl₂ and KOH pellets, and Teflon), affinity to water (hydrophobic versus hydrophilic).

These experiments tell us that the barriers of different material all cause avoidance responses in a similar fashion. To test with a higher degree of confidence whether barriers made of different materials act quantitatively alike the following experiments were done.

(b) *Bilateral Stimuli* Taking dielectric properties as an example, let us consider two equal-sized plate barriers, one made of plastic with dielectric constant $\epsilon \sim 3$ and one made of aluminum with $\epsilon \sim \infty$, mounted onto the two barrier mountings. At the start of the experiments, they are positioned 1.5 mm from the sporangiphore from opposite directions. The dielectric environment is highly asymmetric. If the avoidance response depended on the dielectric constants of the barriers, one would expect the sporangiphore to bend consistently away from one of the two barriers. No tropic response was found. We conclude that the dielectric properties of the barriers are irrelevant. Similar experiments involving pairings of glass versus activated charcoal and ordinary glass versus infrared absorbing glass were done to test whether the sporangiphore can distinguish between barriers of different gas adsorption properties or different infrared absorbing properties. In no case did the sporangiphore show preference in bending. We conclude that the avoidance response is independent of the electric, gas-adsorbing, and electromagnetic radiation-absorbing (including ultraviolet, visible, and infrared light) properties of the barrier. These results suggest strongly, by elimination, that barriers act purely by their aerodynamic effect.

(C) *DISTANCE DEPENDENCE FOR LARGE BARRIERS* The maximal rate of bending measured in the closed avoidance apparatus (Fig. 1) increases as the distance between the barrier and the sporangiphore decreases, to an extrapolated maximum of 1.7°/min at zero distance. It drops to zero at a distance of about 6–10 mm. More precise measurements will be reported by Lafay and Matricon (in preparation).

(a) *Dependence on Size of the House* In 1971, Johnson and Gamow re-

ported that the avoidance response does not occur in still air. In their experiments, a sealed glass house ($2.5 \times 2.5 \times 7.5$ cm) was used to minimize air currents. They found a very weak (if any) avoidance response, at least an order of magnitude weaker than that found in the presence of normal laboratory air movements. Contrary to their report, we find inside a sealed (6.2 cm)³ house that $(d\theta/dt)_{\max}$ is at least half of that in open air.

Dimension of cubic house	$(d\theta/dt)_{\max}$
cm	
2.5	$1.0^\circ \pm 0.25^\circ$ (3 experiments)
6.2	$1.25^\circ \pm 0.2^\circ$ (6 experiments)
No house	1.5–2° (many experiments)

(b) *Air Movements near Barrier and Specimen* Since the key factor may be the air movements in the vicinity of the sporangiophore these movements were studied for vertical barriers by the laser-smoke particle procedure described in General Methods (V). The movement pattern around the sporangiophore varies with the distance (d) between it and the barrier.

$d = 1$ mm (Fig. 7 A): Near the barrier the wind is parallel to it, preferentially vertical with zero velocity at the barrier. Between the sporangiophore and the barrier the velocity is less than $100 \mu\text{m/s}$. Beyond the sporangiophore the air speed increases more sharply. Thus, the effects of a barrier are three-fold: (a) It quiets down the nearby air movements. (b) Near the barrier the

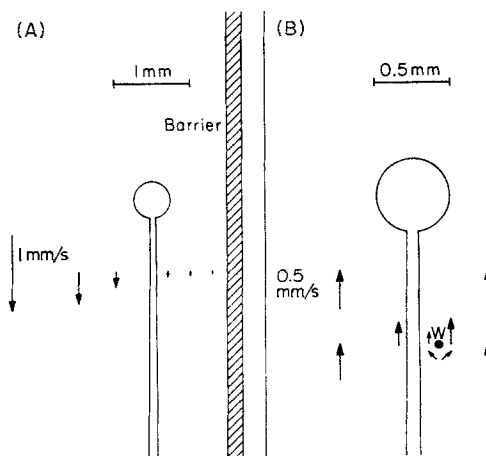

FIGURE 7. The effect of barriers on the air movements near the sporangiophore growing zone. The arrows indicate magnitude and direction of the velocity of the air movement at the points in space. (A) The effect of a large barrier 1 mm away and (B) the effect of a $50\text{-}\mu\text{m}$ wire (W) 0.1 mm away from the sporangiophore. In both cases, the barriers quiet the air movement in the region between the sporangiophore and the barrier.

air movement is parallel to it and to the specimen. (c) It causes a gradient of the longitudinal velocity component, hence an asymmetry between the proximal and the distal sides.

$d \geq 1$ mm: The asymmetry of the air movements across the sporangiophore decreases with increasing distance of the barrier. At $d = 5$ mm, the air speed 1 mm proximal and distal is 1 mm/s versus 1.5 mm/s. At $d = 10$ mm, no noticeable difference is found. At this distance also the avoidance response disappears. Thus the distance dependence of the asymmetry of longitudinal air movements between the two sides of the sporangiophore correlated well with that of the bending rates.

(D) DISTANCE DEPENDENCE FOR A THIN WIRE BARRIER The experiments were done in a standard avoidance apparatus with the barrier mountings replaced by a thin wire (tungsten or nylon, 50- μ m diameter, 4 cm long). The wire was placed horizontally, perpendicular to the sporangiophore and to the focal plane of the measuring microscope.

To elicit a significant avoidance response the thin wire must be adjacent to the middle of the growing zone (~ 1 mm below the sporangium). Thus, just as in the case of light, the sensor is at the site of the response, i.e. in the growing zone.

At the beginning of the experiment, the barrier is positioned approximately 0.7 mm below the sporangium so that the barrier stays for a few minutes adjacent to the middle of the growing zone while the sporangiophore grows at a rate of about 0.05 mm/min. The bending rate decreases rather slowly with increasing barrier distance (Fig. 8). The sporangiophore senses the presence of a 50- μ m wire as far as 1 mm away. To explain this remarkably weak distance dependence, the effect of the wire on the air movement near the sporangiophore was examined.

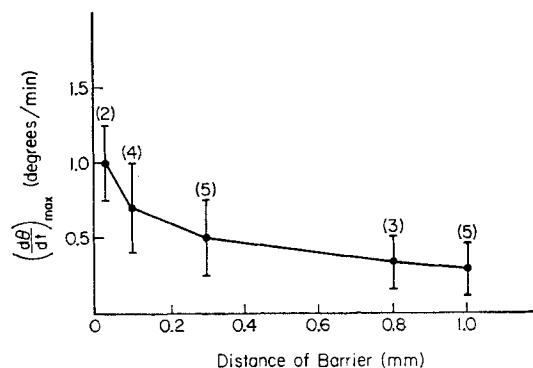

FIGURE 8. Dependence of the avoidance response on the distance from a thin wire barrier. The experimental procedure is described in the text. The number in parentheses above each data point indicates the number of sporangiophores used. Error bars indicate standard deviations of the means.

A representative pattern of the air movement around the sporangiophore and the wire is shown in Fig. 7 B. The distance between the wire and the sporangiophore is 0.1 mm. The wire causes a conspicuous asymmetry of the air movements, slower on the proximal than on the distal side. For the characteristic air speeds occurring inside these houses (section IIIA), the Reynold's number for the flow around the wire is very small ($Re \sim 0.001$). Simple aerodynamic considerations indicate that the flow will be seriously disturbed up to distances comparable to the dimension of the object. At greater distances the velocity disturbance should fall off inversely with distance. This weak dependence may explain the weak distance dependence of the avoidance response to a horizontal wire.

(E) LIGHT ADAPTATION AND THE AVOIDANCE RESPONSE The avoidance response is not affected by the level of light adaptation or by the presence of diffuse light. Even at high light intensity (20 mW/cm^2), where the sporangiophore is no longer able to respond to any unilateral or bilateral increment of light intensity, the sporangiophore still shows normal avoidance response. This finding is in agreement with the finding of Ortega and Gamow (1970) that after a saturating light stimulus the avoidance growth response can still be elicited.

(IV) House Growth Responses

(A) SIMPLE HOUSE GROWTH RESPONSE A house placed over a single sporangiophore previously standing in open air causes a transient positive growth response with a latency of about 2 min, and a negative one upon removal of the house (Fig. 9). This effect is not very sensitive to the size of the house. Houses from 2.5 to 10 cm give quantitatively similar positive growth responses. The characteristic air speeds (section IIIA) decrease from 2–5 mm/s to 0.02–0.1 mm/s as the house size is diminished.

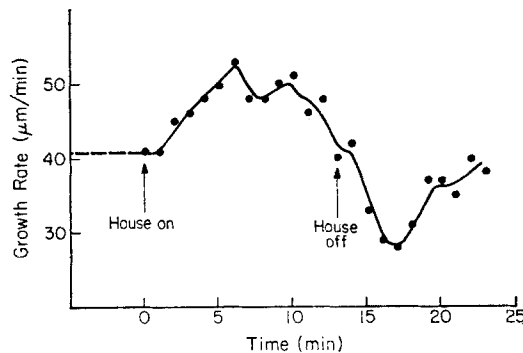

FIGURE 9. House growth response. The house ($5 \times 5 \times 7.5 \text{ cm}$) was lowered and raised periodically, 13 min on and 10 min off, for a total of three periods (69 min). The average is plotted.

The house effect can be explained by the quieting of random wind due to enclosure. The average air speeds drop from faster than 10 cm/s in open air down to less than 1 cm/s in the large house (10 cm) and to less than 1 mm/s in the small house (2.5 cm). Houses of different sizes cause similar house effects. A 10-fold decrease in wind speed apparently saturates the response.

(B) HOUSE-WITHIN-HOUSE EFFECT The house effect occurs not only in open air, but also when the sporangiphore is already inside a bigger completely closed house. The setup is shown in Fig. 10. The inner house could be slipped over the sporangiphore from the outside through the roof of the outer house.

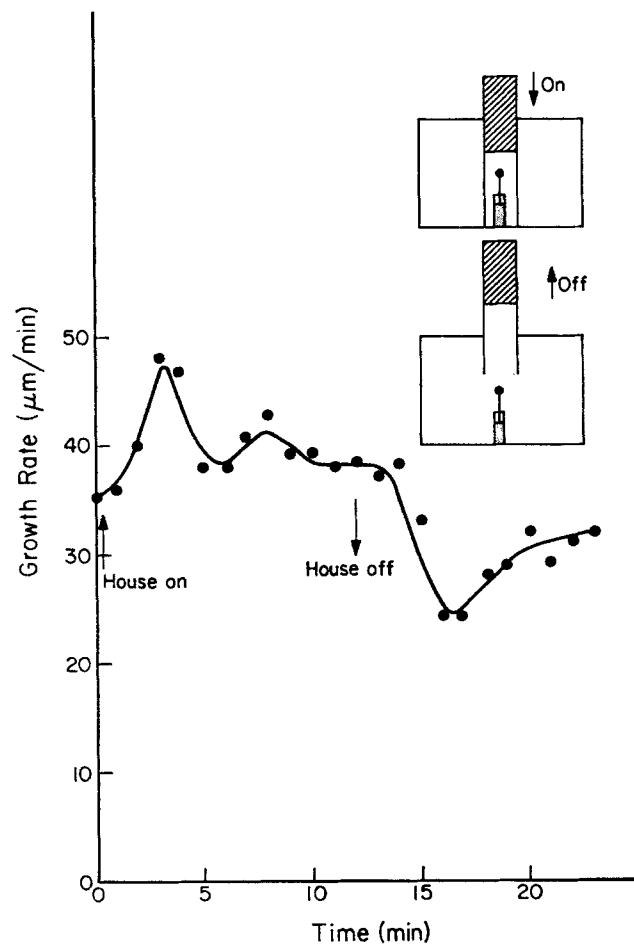

FIGURE 10. House-within-house growth response. The inner house (2.5 x 2.5 x 9 cm) can be slipped over the sporangiphore from the outside through a hole in the roof of the outer house (15 x 15 x 12.5 cm). Both houses are made of Lucite. The characteristic air speed in the outer house is 4–6 mm/s, in the inner house 0.5–0.8 mm/s.

With the inner house lifted, the characteristic air speed is 4–6 mm/s. With the inner house lowered it drops to 0.5–0.8 mm/s. The outer house alone reduces the air speed from faster than 10 cm/s to 4–6 mm/s and causes a positive growth response. The lowering of the inner house reduces the air speed by a factor of about 8 and causes a second positive growth response.

(V) *Specific Tests of the Chemical Self-Guidance Hypothesis*

The experiments described so far agree with the hypothesis that air movements in any direction mediate the house growth response and longitudinal ones the avoidance response. To strengthen this hypothesis we must positively rule out alternative explanations. In the Appendix this is done for alternatives involving electrostatics, temperature, and humidity. Here we wish to discuss the possibility that barriers act by limiting the diffusion path of the effector molecules rather than by modifying their convection.

(A) DO BARRIERS ACT BY MODIFYING THE DIFFUSION OF THE EFFECTOR? Since the avoidance response is the same for barriers of any composition, it would have to be assumed either that all barriers adsorb the gas X similarly or that they all reflect it similarly. If barriers adsorb the gas X , the gas must inhibit growth since growth speeds up on the side proximal to the barrier. Conversely, if barriers reflect the gas, the gas must stimulate growth. We have therefore two alternative models, i.e. (a) the growth promoter-reflection model and (b) the growth inhibitor-adsorption model.

(a) *Disproof of the Growth Promoter-Reflection Model* Before discussing experimental tests of this model, the fate of the effector molecules should be considered. A sporangiophore in a closed house (6.2 cm) gives the same response to a barrier whether the barrier is moved close immediately after the sporangiophore is put into the house, or many hours later. It occurs even if 50 additional sporangiophores have been in the closed house for several hours before the barrier is moved up to the specimen. This experiment shows that in this model the simple concept of continuous emission of a persistent gas cannot be correct. If it were true, the background concentration of gas X would keep building up. A steady-state background concentration can only occur if the gas disappears, either because it decays or because the barrier and the walls adsorb it.

Since for the moment we are assuming that all barriers reflect the gas X , we must also assume that the gas X decays into something which no longer promotes sporangiophore growth. A lower limit for the half-life time of X can be estimated from the fact that a barrier at a distance of 5 mm or more can cause an avoidance response. This implies that the gas X should live long enough for a significant portion of the gas to diffuse to the barrier and back, i.e. a distance of 1 cm or longer. This diffusion process takes $\tau = x^2/2D$ s (x = distance, D = diffusion coefficient of gas X). Putting in $x = 1$ cm and $D = 0.15$ cm²/s, we

obtain $\tau = 3$ s. Thus this model requires that the half-life of gas X should be at least a few seconds. Three kinds of experimental tests disprove the promoter-reflection model.

(1) Avoidance of “adsorptive” barriers. If a barrier alters the effector concentration by reflecting the effector, strongly adsorptive materials should be less effective or cause negative avoidance. However, activated charcoal is as effective as Teflon or glass barriers (section IIIB).

(2) Avoidance of thin wires. A thin wire (diameter $\sim 50 \mu\text{m}$) causes a detectable avoidance response at a distance of $1,000 \mu\text{m}$ (section IIID). In this situation the reflection from a thin wire would cause an extremely small perturbation in the distribution of the effector gas (zero gradient) at the barrier itself, and a fortiori near the growing zone.

(3) The failure of detecting the effector by bioassay. Two classes of experiments designed to show the effect upon a test specimen of an effector emitted by a large number of sporangiophores invariably yield negative results.

Experiment 1 (Fig. 11): The room air stream (or compressed tank air) flows down on the tested sporangiophore at a constant speed of 15 cm/s. Changes of the composition of the air stream are made by simultaneously switching two three-way valves, S_1 and S_2 . Switching takes less than 0.5 s. Pathway 2 consists of a glass chamber containing about 1,000 stage 4b sporangiophores. The promoter-reflection model predicts a positive growth response when the air stream (without change of flow rate) is switched to pathway 2 and vice versa. The data (Fig. 11) show no growth response upon switching. A wide range of numbers of stage 4b sporangiophores and of flow speed was tested, but none produced a growth response.

Experiment 2. The setup is the same (Fig. 10) as the “house-within-house” experiment described in section IV except that between the inner house and the outer house there are a few thousand sporangiophores uniformly spaced such that a few dozen sporangiophores are within 2.5 cm of the tested sporangiophore. Thus, the effector concentration outside the inner house should be higher than inside. Since many sporangiophores are within 2.5 cm of the tested sporangiophore, there should be an increase in the effector concentration upon lifting the inner house even if the effector decays with a half-life as short as 1 s. Therefore, there should be a reversed house-within-house effect, i.e. a positive growth response when the inner house is lifted. In contrast, experimental results show a normal house-within-house effect.

(b) *Disproof of the Growth Inhibitor-Adsorption Model* The experiments described above speak strongly against the promoter-reflection model, but they are compatible with the growth inhibitor-adsorption model. However, the inhibitor-adsorption model must also be rejected because:

(1) It cannot explain the wind growth response. The air current will sweep away the emitted gas and therefore decrease the gas concentration near the

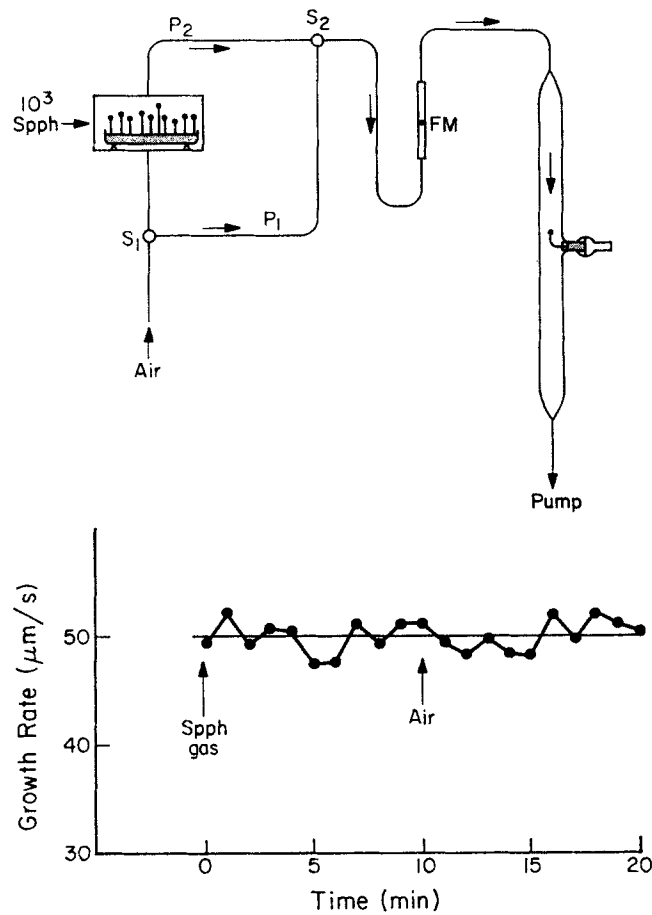

FIGURE 11. Attempted bioassay of growth effector emitted by many sporangiophores. Top: Experimental setup. Pathway 2 (P_2) includes a glass chamber containing about 1,000 stage 4 sporangiophores (spph). Bottom: The air current produced by suction was switched between the two pathways at the times indicated. This was done periodically, 10 min P_1 , 10 min P_2 , for a total of five periods (100 min). The average is plotted. Legend: P_1 , P_2 , pathways; S_1 , S_2 , switches; FM, flowmeter.

growing zone. It should cause positive growth responses, contrary to the experimental results (section IA).

(2) Two sporangiophores avoid each other. Two sporangiophores are tested for their effects upon each other in a situation of accurate parallel alignment (Fig. 12). The midplane between the sporangiophore is a plane of symmetry and should act like a virtual reflecting plane irrespective of the distribution of sources and sinks on the sporangiophore. Therefore, if all real barriers, including sporangiophores, adsorb, this virtual barrier should reflect. In this experiment, one should see a reversal of the avoidance response, causing the

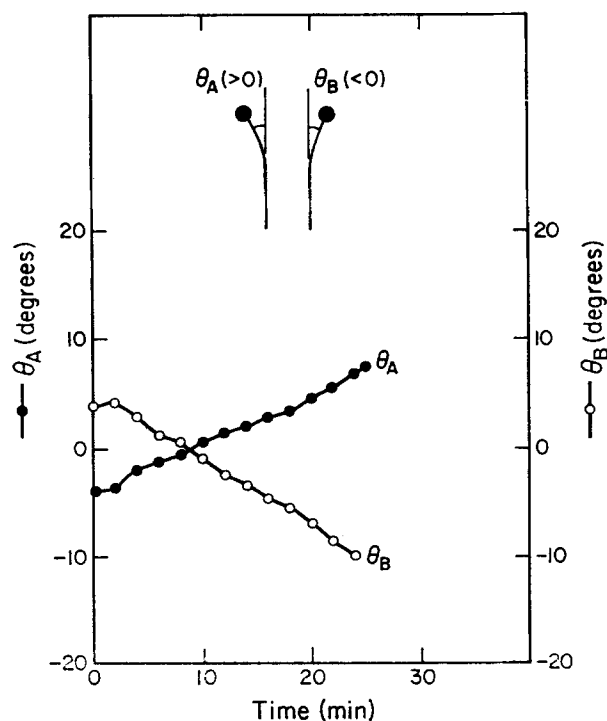

FIGURE 12. Two sporangiophores avoid each other. At $t = 0$, two parallel sporangiophores growing in different vials inside the standard avoidance setup were brought to a distance of 0.6 mm from each other, and were accurately aligned as to height. The sporangiophores bent away from each other.

sporangiophores to move toward each other. Actual tests clearly show mutual avoidance of the aligned sporangiophores,² thus disproving the inhibitor-adsorption model. We conclude that the barriers act neither by adsorption nor by reflection of a gas X .

(B) THE BARRIERS AS AERODYNAMIC OBSTACLES We return to the assumption that barriers affect the distribution of the effector by altering the ambient wind pattern near the sporangiophore.

(a) *Localization of the Emitter* The sporangiophore cannot distinguish an activated charcoal barrier from a glass barrier at a distance of 0.5 mm from the sensor (section IIIB). This suggests that the majority of the effector molecules do not reach the barrier. If the emitter were 0.5 mm or farther away from the sensor, the emitted molecules would have to diffuse through the ambient air at least 0.5 mm to reach the sensor. A significant portion of the effector molecules would reach the barrier and the adsorptivity of barriers ought to

² Two sporangiophores avoid each other regardless of their mating type.

matter. Since it does not, the distance between the emitter and the sensor must be much less than 0.5 mm. Thus, the emitter must be close to the sensor, or be identical with it. Furthermore, the growing zone must readsorb the emitted effector molecules at such a rate that most of the effectors fail to escape from the vicinity of the growing zone.

(b) *Readsorption Model* Based on the above considerations, we formulate a readsorption model with the following assumptions:

(1) The sporangiophore emits a volatile growth-promoting substance X at a constant rate. The emitter of X is interspersed with the sensor in the growing zone. The emission points themselves might be the sensing points, sensing the net emission from these points.

(2) The growing zone readsorbs the emitted effectors at such a rate that most of the effectors fail to escape from the vicinity of the growing zone.

(3) The local growth rate of the sporangiophore increases when the local adsorption rate of X at the surface of the growing zone increases (or when the net loss rate of X diminishes).

The major difference between the present model and the promoter-reflection model (section VAa) lies in the assumption that the barrier acts by modifying convection rather than diffusion. The present model has been treated mathematically, both for still air and for transverse winds (Jan, 1974). The concentration distribution can be determined by solving a diffusion-convection equation with an appropriate boundary condition. The boundary condition at the surface of the growing zone is formulated according to the assumptions of the model:

$$A - kC(R, \theta) = -D \left. \frac{\delta C(r, \theta)}{\delta r} \right|_{r=R}.$$

Cylindrical coordinates are used. $C(r, \theta)$ is the concentration distribution of X ; R is the radius of the sporangiophore; A is the emission rate of X per unit surface area; k is the adsorption rate constant; and D is the diffusion constant of X in air. $kC(R, \theta)$ is the rate of readsorption. An increase in this term connotes a growth-promoting stimulus.

Solution of the diffusion-convection equation for slow transverse winds ($Re < 1$) using the Oseen approximation (Van Dyke, 1964), shows that the concentration of effector is higher on the leeward side, predicting a tropic response into the wind. Transverse winds, and hence random winds, also decrease the *average* concentration of the effector near the growing zone. Thus the quieting of winds increases the concentration of the gas X near the sensor, and increases the growth rate. This model also reasonably accounts for responses to thin wire barriers, which may be expected to produce a strictly local quieting of winds.

Quantitatively, these effects depend critically on the value of the adsorption

coefficient k , in relationship to the sporangiophore radius R , and the diffusion coefficient of the gas X in air, D . The critical parameter is the dimensionless number $\mu = Rk/D$, which is proportional to the readsorption rate. It compares R to the length D/k . This characteristic length has a simple physical meaning. It measures the mean distance to which effectors diffuse before they are readsorbed. The physical meaning can be clarified further by focusing attention on the fate of individual molecules: each molecule, after emission, will go on a random walk which may end by adsorption. During such a random walk it will reach a maximal excursion b . Consider the fraction $P_\mu(b)$ of molecules whose greatest excursion from the source before readsorption is less than b . This function can be calculated in closed form. It represents the fraction which never "sees" an adsorbing barrier at distance b . In the vicinity of the emitting surface $P_\mu(b)$ has the form

$$P_\mu(b) = \frac{1}{1 + 1/(\mu \log(b/R))}.$$

This function is plotted in Fig. 13 for various values of μ . We require that the majority of the molecules do not reach a nearby barrier (say, $b/R = 5$); substituting numbers into this formula we obtain the explicit requirement that $\mu > 5$ (Jan., 1974, p. 141).

On the other hand, we can show that if μ is too large there will be no rheotropic response. In the presence of a transverse wind of velocity u the fractional difference of adsorption on leeward and windward side is approximately

$$\frac{uR}{2D} \frac{1}{1 + \mu} = \frac{Pe}{2} \frac{1}{1 + \mu},$$

where Pe is the Peclet number ($= uR/D$) which compares convection with diffusion. For small Peclet numbers the asymmetry increases with air speed and decreases with the adsorption rate constant. For $\mu \gg 1$, the wind causes very little asymmetry. For a transverse wind velocity of 3 cm/s and $\mu = 5$, the asymmetry is about 1%. Since the sporangiophore exhibits a rheotropic response to a 1.5-cm/s transverse wind, the sporangiophore, according to our calculations, must be able to detect an asymmetry of 1% between the leeward and the windward sides. Thus, for $\mu \sim 5$ we obtain both a reasonable efficiency of readsorption and a reasonable asymmetry in the presence of transverse wind.

The constant k ($= \mu D/R$) has the dimension of velocity and is related to α , the probability that a molecule is adsorbed at any one encounter with the surface by the relation $k = \alpha D/L$, where L is the mean free path between collisions with air molecules. Thus, for $\mu = 5$, we have $\alpha = 10^{-3}$ (with $L = 10^{-6}$ cm and $R = 5 \times 10^{-3}$ cm). In other words, our model requires the probability that a molecule be adsorbed at any one encounter with the growing zone to be of the order of 10^{-3} .

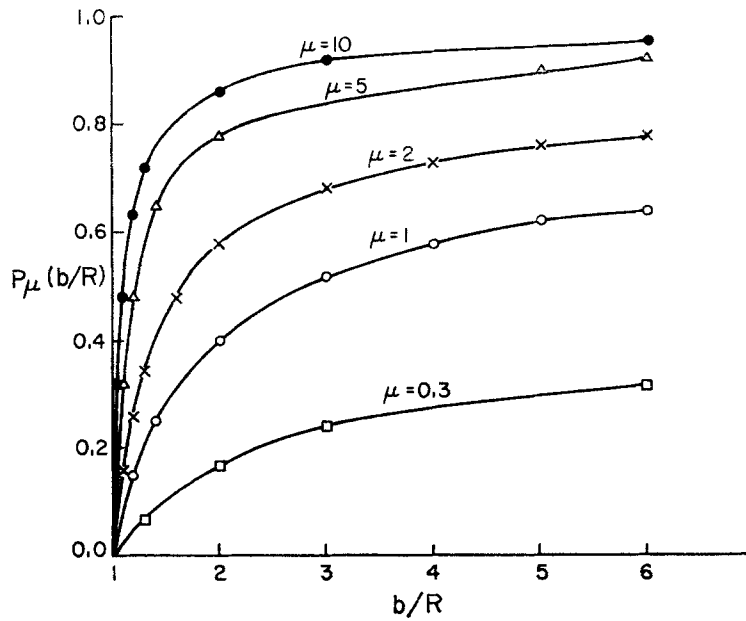

FIGURE 13. The distribution of molecules around a cylindrical emitter-adsorber, radius R , in the readsorption model, without wind. The function plotted is

$$P_{\mu}(b/R) = \frac{1}{1 + 1/(\mu \log(b/R))}$$

$P_{\mu}(b/R)$ = fraction of molecules readsorbed without reaching distance b . In the cylindrical case every molecule is eventually readsorbed. $\mu = Rk/D$ = dimensionless number which measures the ratio between the radius of the source, R , and the mean excursion, D/k , of the molecules from the axis.

We postulated that the local growth rate of the sporangiophore is regulated by the local adsorption rate of the effector (assumption 3). But we did not specify how the sporangiophore detects the adsorption rate. One alternative is to assume that the sporangiophore has some receptor organelle on the surface of the growing zone which enables it to detect the effector concentration. Another alternative which seems more economical from the standpoint of *Phycomyces* is the assumption that the emitter and the detector are the same structure, in other words, that the sporangiophore senses the net emission of effector. An increase in adsorption rate decreases the emission and hence causes higher growth rate. In either model we would expect that any material which can be adsorbed to the emitter or sensor has the potential to modify the interplay between emission and adsorption and to induce a growth response. This might explain the finding referred to in section IA that many volatile substances cause negative growth responses of the sporangiophore. Either model implies that a substance which causes a growth response is not necessarily the growth effector emitted by the sporangiophore.

(c) *Future Experimental Tests of the Readsorption Model* (1) In this model, the barriers act solely by modifying convection. It predicts that in a sufficiently quiet house the avoidance response should vanish. The slowest random air movement we have been able to achieve is 0.02–0.1 mm/s, inside a 2.5-cm house. In this house avoidance was at least half of that in open air. Yet, on general physical principles an absolute threshold of wind detection must exist. Our failure to establish this threshold is a fundamental weakness of our analysis. Conceivably, in an ideally quiet house the self-generated microcirculation discussed in footnote 1 will still be sufficient to mediate the avoidance response. This limit was certainly not reached by our experimental designs.

(2) The rheotropic response into transverse wind (direct direction sensing) cannot be responsible for the avoidance response. Consider a vertical specimen and a flat barrier parallel to it: the random winds near such a barrier are overwhelmingly tangential to the barrier, with components longitudinal and transverse to the specimen. The transverse component would yield a rheotropic response parallel to the barrier, not an avoidance response. The longitudinal component could yield an avoidance response. To establish a closer relation with theory, experiments are needed with longitudinal winds, with known gradients across the sporangiophore.

(3) Mutant selection: There should exist “wind-blind” and “barrier-blind” mutants. We do not have an efficient way for selecting barrier-blind mutants. However, an efficient method for selecting wind-blind mutants has been developed recently. A mutant which exhibits nonrheotropic behavior can belong to one of three classes: (A) “stiff” mutants which have defects in the output machinery and thus exhibit abnormal behavior in all the tropic responses, (B) slow growers which will give slow and very weak tropic responses, and (C) specific rheotropic mutants which are abnormal only in the rheotropic responses but not in phototropism.

After screening about 30,000 nitrosoguanidine mutagenized colonies, eight nonrheotropic mutants were obtained. Six belong to class A, two to class B, none to class C. The mutation rate for nonrheotropism appears to be low compared to that for obtaining stiff mutants in nitrosoguanidine mutagenesis. If further work yields mutants of type C their behavior in the avoidance test will help to clarify the relation between the two effects.

DISCUSSION

The experiments discussed in the preceding sections establish many facts about the responses of *Phycomyces* sporangiophores to barriers, houses, and winds. We find that: (a) The sporangiophore shows a rheotropic response into the wind to transverse winds of velocity ≥ 1 cm/s. (b) A step-up in wind velocity (wind from any direction) causes a negative growth response of the sporangiophore. (c) Winds of 15–30 cm/s parallel to the barrier and the sporangiophore

eliminate the avoidance response. After stopping the wind, avoidance occurs promptly. (d) The avoidance response occurs in a closed chamber with a magnitude at least half of that in open space. (e) The avoidance response is independent of the dielectric, magnetic, gas-adsorbing, electromagnetic radiation-absorbing (ultraviolet, visible, and infrared) properties of the barrier. (f) The sensor of the avoidance response is situated in the growing zone and may be coextensive with it. (g) The magnitude of the avoidance response (defined as the maximal bending rate) decreases with increasing distance of the barrier, disappearing at about 6–10 mm. (h) Enclosure of the sporangiophore causes a positive growth response (house growth response). (i) If the avoidance response is mediated by a volatile substance, the barriers are not reached by diffusion away from the immediate vicinity of the sporangiophore growing zone. (j) Electrostatic fields, humidity, mechanical stretch, and temperature have been excluded as possible signals mediating the avoidance response. (k) Air movement seems to correlate well with all three effects.

The physical nature of the signal has not been positively identified. We postulate that the responses are all mediated by a volatile growth effector emitted and detected in the growing zone of the sporangiophore.

Several simple forms of this notion are incompatible with experimental results, notably with the invariable failure to detect the hypothetical gas. The present model postulates that the sporangiophore emits and readsorbs a volatile growth-promoting effector and the barrier modifies the effector distribution by acting as an aerodynamic obstacle. Readsorption is so strong that only a small fraction of the emitted molecules actually escapes or reaches the barriers. This model also explains the failure to detect the hypothetical gas.

The house effect is a transient one, similar to the growth response to a step-up in light intensity (Foster and Lipson, 1973). Therefore the sporangiophore must adapt to the level of (longitudinal) wind speed. The avoidance response to a barrier is a sustained tropic response, continuing indefinitely if the experiment is carried out in a tropostat, a device whereby the barrier is kept close to and parallel to the growing zone at all times. To explain this sustained response, an apparent lack of adaptation, we are confronted with the same alternatives as in the case of the responses to light (Dennison and Bozof, 1973): averaging of adaptation around the circumference, or strictly local adaptation combined with the effects of spiral growth.

The avoidance response certainly has a great survival value for *Phycomyces*. In nature, the *Phycomyces* mycelium is likely to be found in some dark, damp cracks. For its spores to be dispersed, the sporangiophore has to find its way out. If there is light, the sporangiophore can use light as a cue. In darkness, the avoidance mechanism can provide a way for the sporangiophore to get out.

The avoidance response is not unique for *Phycomyces*. It has been observed also in cellular slime molds (Bonner and Dodd, 1962). The behavior of the fruiting

bodies of slime molds is quite similar to that of the sporangiphore of *Phycomyces*. They avoid each other, avoid barriers and thin rods, and bend into wind. The avoidance in slime molds is also independent of the material of the barrier except that the fruiting bodies bend toward activated charcoal instead of away. This finding has been interpreted as supporting the hypothesis that the avoidance response is mediated by a gas. However, it was claimed that the culminating fruiting bodies are extremely sensitive to temperature differences. Lacking the control of a black barrier other than charcoal, the results with charcoal could also be interpreted as orientation toward a warmer body. Bioassays similar to ours (section V) by Bonner and Dodd (1962) were equally unsuccessful as were their attempts to identify the hypothetical gas.

Another similar case is the "group" effect and rheotropic responses of developing *Fucus* eggs (Bentrup and Jaffe, 1968; Jaffe and Neuscheler, 1969). The cell polarity of the developing eggs of the brown alga *Fucus furcatus* was found to be determined rheotropically in seawater. At pH 6.5, the cells tend to form their rhizoidal pole downstream. Qualitatively, the downstream response concurs with the positive group effect, i.e. the phenomenon that nearby zygotes tend to initiate their rhizoids toward each other. The effect is pH dependent. These phenomena led to the hypothesis that they are mediated by a growth-stimulating substance emitted by the egg. However, when the authors analyzed their results quantitatively, a very complicated model was needed involving two hypothetical effectors, one small and one large (molecular weight greater than 10^7 !), without any direct evidence for the existence of such molecules.

The general picture emerging from the studies of the organisms which grow away (or toward) each other (or another object) and also show rheotropic responses is that the phenomena seem to be mediated by diffusible substances. Further analysis then reveals many difficulties which cannot be explained by a simple picture, notably the invariable failure to detect the hypothetical diffusible substance. Although the model we proposed can reasonably account for the experimental results, more critical tests, such as the ones proposed in section V, are needed to tell whether it provides the correct answer.

APPENDIX

In this Appendix we summarize briefly specific tests ruling out various alternative hypotheses regarding the clue or clues involved in the responses studied.

(A) Electrostatic Effects

(a) ELECTROSTATIC BENDING It is a common observation that sporangiphores of *Phycomyces* are sensitive electrometers since any charged body (a rubbed plastic, for instance) causes strong attraction by virtue of induced charges. The notion therefore could be entertained that the sporangiphore always carries small electric charges, or net polarization of charges, that these charges induce countercharges or polarization

in the barrier, then the mechanical force so generated causes subliminal bending, and then finally, this stretch stimulus mediates the avoidance response. This notion was tested directly by examining controlled electrostatic deflections of sporangiophores situated between vertical condenser plates (separated by 0.4 cm and charged up to ± 400 V). A field of 1,000 V/cm causes visible passive bending of about 2° , but no significant tropic response to this passive bending. In contrast, the avoidance response evoked by either one of the same condenser plates (uncharged), placed close to the sporangiophore, occurs without visible preliminary bending. This experiment eliminates electrostatically induced bending as the cause of the avoidance response.

(b) ELECTROSTATIC DETECTION It is known that some electric fish can detect weak electric fields with their extremely sensitive electroreceptors. It has been suggested (Lissmann, 1958; Lissmann and Machin, 1958) that fish with weak electric organs set up electric fields in the water and detect any distortion of the field caused by the presence of objects with different conductivity. Similarly *Phycomyces* might use electrostatic effects as the cue for the avoidance response. As in most plant cells, there exists a resting potential between the inside and the outside of a sporangiophore submerged in water of low salt concentration, minus 80–90 mV inside. This membrane potential will normally be cylindrically symmetrical around the cylinder axis. This symmetry might be destroyed by any dielectric brought into the vicinity of the sporangiophore. The dielectrics could thus affect membrane processes controlled by membrane potentials, and could thereby induce an asymmetry in growth. This hypothesis is ruled out on the basis of three experiments:

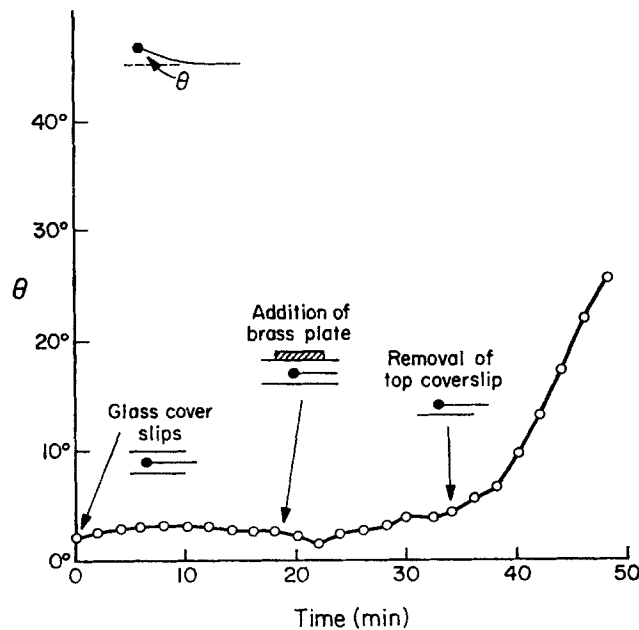

FIGURE 14. The sporangiophore in a dielectrically highly asymmetric environment. The sporangiophore does not exhibit a tropic response when placed between two barriers of drastically different dielectric properties. θ indicates the angular deviation from the horizontal direction (upward positive).

(1) The experiments on electrostatic bending show that the sporangiophore does not respond to a constant electric field (up to 1,000 V/cm).

(2) Unilateral tests described in section IIIb: Semiquantitative comparison of the avoidance of a mineral oil ($\epsilon \sim 2$) meniscus with that of a water ($\epsilon \sim 80$) meniscus, both used as horizontal barriers, showed no detectable difference.

(3) Bilateral tests described in section IIIb: The sporangiophore does not show tropism when sandwiched between dielectrically highly dissimilar barriers (plastic with $\epsilon \sim 3$ vs. aluminum with $\epsilon \sim \infty$). A similar but more critical experiment is described in the following:

Two parallel horizontal cover glasses (0.1 mm thick, $\epsilon \sim 5$) 3 or 1.5 mm apart gave no tropic response for a horizontal sporangiophore placed symmetrically between them (Fig. 14). A brass plate ($\epsilon = \infty$) 1 mm thick was then laid on top of the upper cover glass making the double barriers dielectrically highly asymmetric.

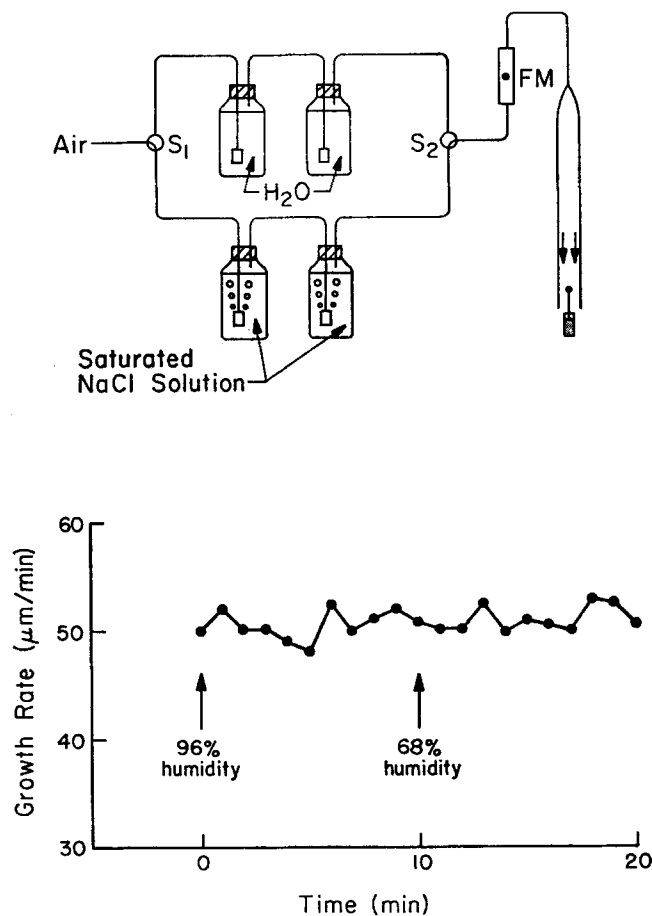

FIGURE 15. Humidity cycling. A uniform air current, alternating between two pathways containing water and saturated NaCl solutions, with relative humidity 96 and 68%, respectively, is blown on the sporangiophore. The data plotted are average values for five periods. Legend: S, switch; FM, flowmeter.

Unlike the bilateral tests, in this case the surface properties of the two barriers facing the sporangiophore are the same. The only difference of the two barriers is the dielectric constant. Still no tropic response was seen.

(B) *Humidity and Temperature Cycling*

Johnson and Gamow (1971) suggested that water vapor may be the cause of the avoidance response. To test this idea, experiments involving vertical downward air currents of 3 cm/s were performed. When the humidity of the air current was alternated between 68 and 96% in 20-min cycles, no measurable growth responses to the changes in humidity were observed (Fig. 15). This experiment also rules out the possibility that the responses are mediated by minute temperature changes, since humidity cycling implies transpiration and temperature cycling.

One of the arguments of Johnson and Gamow in favor of water vapor as the cause of the avoidance response is based on a series of experiments by Thimann and Gruen (1960) showing a negative tropic response by the sporangiophore to the local application of a small drop of distilled water to the surface of the sporangiophore. The time-course and magnitude of this response are similar to those of the avoidance response. We have found that this effect is not specific to water. The same effect occurs in response to covering one side of the growing zone with vacuum grease or protein solutions. It would appear that these effects represent extreme cases of avoiding a barrier. We may be dealing with local blockage of the escape of gas X.

We wish to thank Dr. Philip Saffman for many instructive discussions on general principles and specific questions of aerodynamics, Mike Walsh for designing and building the elegant apparatus shown in Fig. 1, Jeanette Navest for much technical help, and K. Bergman and R. I. Gamow for many ideas and discussions.

We wish to acknowledge support of this work by NSF Grant BMS 70-00999-04. R. J. Cohen was supported by NIH Grant 2F02-GM31706 and Y. N. Jan by the McCallum Fund and a Calbiochem Fellowship.

Received for publication 23 December 1974.

REFERENCES

- BENTRUP, F. W., and L. F. JAFFE. 1968. Analyzing the "group effect" rheotropic responses of developing *Fucus* eggs. *Protoplasma*. 65:25-35.
- BERGMAN, K., P. V. BURKE, E. CERDÁ-OLMEDO, C. N. DAVID, M. DELBRÜCK, K. W. FOSTER, E. W. GOODELL, M. HEISENBERG, G. MEISSNER, M. ZALOKAR, D. S. DENNISON, and W. J. SHROPSHIRE. 1969. *Phycomyces*. *Bacteriol. Rev.* 33:99-157.
- BONNER, J. T., and M. R. DODD. 1962. Evidence for gas-induced orientation in the cellular slime molds. *Dev. Biol.* 5:344-361.
- DENNISON, D. S., and R. P. BOZOF. 1973. Phototropism and local adaptation in *Phycomyces* sporangiophores. *J. Gen. Physiol.* 62:157-168.
- DENNISON, D. S., and C. C. ROTH. 1967. *Phycomyces* sporangiophore—fungal stretch receptors. *Science (Wash. D.C.)*. 156:1386-1388.
- ELFVING, F. 1881. En obeaktad känslighet hos *Phycomyces*. *Bot. Not.* 4:105-107.
- ELFVING, F. 1917. *Phycomyces* und die sogenannte physiologische fernwirkung. *Öfersight af Finska Vetenskaps-Societetens Förhandlingar* 59:(a, no. 18):21-55.
- FOSTER, K. W., and E. D. LIPSON. 1973. The light growth response of *Phycomyces*. *J. Gen. Physiol.* 62:590-617.

- JAFFE, L. F., and W. NEUSCHELER. 1969. On the mutual polarization of nearby pairs of Fucaceous eggs. *Dev. Biol.* **19**:549-565.
- JAN, Y. N. 1974. Part II. The avoidance response, the house growth response and the rheotropic response of *Phycomyces*. Ph.D. Thesis. California Institute of Technology, Pasadena, Calif.
- JOHNSON, D. L., and R. I. GAMOW. 1971. The avoidance response in *Phycomyces*. *J. Gen. Physiol.* **57**:41-49.
- LISSMANN, H. W. 1958. On the function and evolution of electric organs in fish. *J. Exp. Biol.* **35**:156-191.
- LISSMANN, H. W., and K. E. MACHIN. 1958. The mechanism of object location in *Gymnarchus niloticus* and similar fish. *J. Exp. Biol.* **35**:451-486.
- ORTEGA, J. K. E., and R. I. GAMOW. 1970. *Phycomyces*: Habituation of the light growth response. *Science (Wash. D.C.)*. **168**:1374-1375.
- SHROPSHIRE, W., JR. 1962. The lens effect and phototropism of *Phycomyces*. *J. Gen. Physiol.* **45**:949-958.
- TANEDA, S. 1955. Reports of Research, Institute for Applied Mechanics. **IV**(no. 14):29.
- THIMANN, K. V., and H.E. GRUEN. 1960. The growth and curvature of *Phycomyces* sporangio-phores. *Beih. Z. Schweiz. Forstw.* **30**:237-263.
- VAN DYKE, M. 1964. *Perturbation Methods in Fluid Mechanics*. Academic Press, Inc., New York.