

Role of Hydrophobic Amino Acid Clusters in the Transactivation Activity of the Human Glucocorticoid Receptor

TOVA ALMLÖF,* JAN-ÅKE GUSTAFSSON, AND ANTHONY P. H. WRIGHT

Center for Biotechnology, Department of Biosciences, Karolinska Institute, Novum, S-141 57 Huddinge, Sweden

Received 15 July 1996/Returned for modification 5 September 1996/Accepted 7 November 1996

We have performed a mutagenesis analysis of the 58-amino-acid τ 1-core peptide, which represents the core transactivation activity of the τ 1 transactivation domain from the glucocorticoid receptor. Mutants with altered activity were identified by phenotypic screening in the yeast *Saccharomyces cerevisiae*. Most mutants with reduced activity had substitutions of hydrophobic amino acids. Most single-substitution mutants with reduced activity were localized near the N terminus of the τ 1-core within a segment that has been shown previously to have a propensity for α -helix conformation, suggesting that this helical region is of predominant importance. The particular importance of hydrophobic residues within this region was confirmed by comparing the activities of alanine substitutions of the hydrophobic residues in this and two other helical regions. The hydrophobic residues were shown to be important for the transactivation activity of both the isolated τ 1-core and the intact glucocorticoid receptor in mammalian cells. Rare mutations in helical regions I and II gave rise to increased transcriptional activation activity. These mutations increase the hydrophobicity of hydrophobic patches on each of these helices, suggesting a relationship between the hydrophobicity of the patches and transactivation activity. However, certain nonhydrophobic residues are also important for activity. Interestingly, helical region I partially matches a consensus motif found in the retinoic acid receptor, VP16, and several other activator proteins.

The glucocorticoid receptor (GR) is a member of a large family of ligand-inducible nuclear transcription factors. Binding of glucocorticoids causes dissociation of the receptor from an inactive complex containing hsp90, allowing translocation into the nucleus and subsequent binding to specific glucocorticoid-responsive elements (GREs) present within glucocorticoid-regulated genes (4, 20, 30). The GR has a modular structure such that different functions, including ligand binding, DNA binding, and transactivation, are performed by discrete domains within the receptor protein. Initially two regions, τ 1 (residues 77 to 262) and τ 2 (residues 526 to 556), were implicated in the post-DNA-binding transactivation activity of the human GR (25, 31). These segments retain activity even when removed from their normal receptor context. τ 1 is the more active of the two transactivation domains (31), and it has recently been shown that a 58-amino-acid peptide (the τ 1-core) retains most of the activity of the intact τ 1 domain in the yeast *Saccharomyces cerevisiae* (14). In addition, a third region near the C terminus of the receptor protein that is highly conserved between different receptors has been suggested to play a role in the transactivation activity of the GR (17).

Accurate initiation of transcription at RNA polymerase II promoters involves the assembly of a transcription complex that consists of RNA polymerase II and a number of basal transcription factors, namely, TFIIA, -B, -D, -E, -F, -H and -J (55). Transcriptional activators are thought to enhance the efficiency of transcriptional initiation by recruiting or modifying components of this basal machinery (79). The GR has been shown to activate transcription from minimal promoters both in vivo (62, 67) and in vitro (23, 70). While the actual mechanism by which DNA-bound GR induces transcription remains unclear, it has been shown that the GR facilitates formation of

active transcription complexes (23, 70). Furthermore, the intact τ 1 domain and the τ 1-core segment can suppress transcription from minimal promoters lacking GRE binding sites in squelching assays in vivo (77) and in vitro (15, 51). Titration of limiting components required for basal transcription in these assays suggests that the τ 1 domain may interact directly with the basal transcription machinery. In kinetic experiments, sensitivity of transcription reactions to squelching coincided with the assembly of the basal transcription complex (49), and thus interactions between τ 1 and the basal transcription machinery may well be involved at this stage during transactivation. Consistent with this observation, transactivation domains from many activator proteins have been shown to interact directly in vitro and/or in vivo with one or more general transcription factors within the basal transcription machinery, such as the TATA-binding protein (TBP) (40, 41, 61, 68, 69), TFIIB (3, 6, 12, 22, 34, 43, 46), TFIIF (37, 57), and TFIIF (78).

In addition to the general transcription machinery, so-called coactivator proteins are needed for the function of eukaryotic activator proteins (28). Several transactivation domains from activator proteins interact directly with coactivator proteins in vitro. This has been shown most extensively for the TFIID complex, where different activators interact with distinct TBP-associated factors (TAFs) which represent coactivator proteins (27). Steroid receptors such as the estrogen and progesterone receptors have been reported to interact with human TAF_{II}30 and *Drosophila* TAF_{II}110, respectively (35, 63). Several putative coactivators that interact with the C-terminal transactivation domains in the ligand binding domains of one or more nuclear receptors have been identified. These include RIP160, RIP140 (10, 11, 29), TIF1 (73), SRC-1 (52), GRIP1 (32), and CBP (38). Two additional proteins, RAP46 (80) and GRIP 170 (19), have recently been demonstrated to interact with the intact GR. SRC-1 and GRIP1 have been reported to enhance the transactivation activity of the GR in transient transfection experiments, while a GRIP 170-enriched fraction from HeLa cells potentiated activation by the GR in a cell-free transcrip-

* Corresponding author. Mailing address: Department of Biosciences, Karolinska Institute, Novum, S-141 57 Huddinge, Sweden. Phone: 46-8-608 9158. Fax: 46-8-774 5538. E-mail: tova.almlof@csb.ki.se.

tion system (19). Coactivators mediating the activity of the $\tau 1$ domain have not yet been identified, but antibody inhibition experiments suggest that $\tau 1$ acts at several stages of transcriptional activation (49), and thus it is likely that coactivators are involved in mediating transcriptional activation.

In spite of their small size, transactivation domains appear to function at several different steps during transcriptional activation via interactions with various target factors. However, little is known about the structural features of transactivation domains that mediate these functions. The $\tau 1$ domain, and particularly the $\tau 1$ -core, is rich in aspartic acid and glutamic acid residues, which suggests that $\tau 1$ may belong to an acidic class of transactivation domains. It also contains several phosphorylated serine residues (7) that contribute to acidity. However, mutational analysis of acidic residues and phosphorylation sites has shown that negative charge per se is not sufficient for activation (1, 47). Structural studies using circular dichroism and nuclear magnetic resonance (NMR) spectroscopy have revealed that $\tau 1$ and the $\tau 1$ -core are largely unstructured in aqueous solution, containing only a minimal amount of α -helical conformation (15). However, under hydrophobic conditions, in the presence of trifluoroethanol, α -helical structure is induced, and three segments with α -helical structure have been identified by NMR spectroscopy under these conditions (15). Proline substitution mutants within these putative α -helices reduce both transactivation activity and the propensity for helix formation, suggesting that the α -helices may be relevant to $\tau 1$ function in vivo (16). The purpose of the present study was to use mutagenesis followed by screening of the mutants in yeast cells to identify amino acids that are critical for the function of the $\tau 1$ domain. We have attempted to interpret the results in light of our previous structural studies. Furthermore, we have assessed the role of the $\tau 1$ -core and selected mutants, in the context of the intact GR, in mammalian cells.

MATERIALS AND METHODS

Plasmids. The single-copy yeast vector pRS315-LexA is derived from the phagemid pRS315 (66) and expresses the *Escherichia coli* LexA DNA binding domain (residues 1 to 87) from a galactose-inducible hybrid *GALI-1*-*PGK* promoter (77). It was constructed by inserting a *Bam*HI-*Sall* fragment containing the *PGK* promoter sequences and the LexA DNA binding domain into a derivative of pRS315 from which the *Sac*I site in the polylinker has been deleted (pRS315 Δ SacI). The LexA amino acids are preceded by Met Val Asn Ser Ser Ser, and there is a unique *Sac*I site directly upstream of the LexA sequence that can be used for insertion of transactivation domain fragments. This plasmid was used to construct pRS315- $\tau 1$ -LexA and pRS315- $\tau 1$ -core-LexA. pRS315- $\tau 1$ -LexA expresses GR residues 77 to 262 ($\tau 1$) fused to the LexA DNA binding domain, and pRS315- $\tau 1$ -core-LexA expresses residues 187 to 244 (the $\tau 1$ -core) fused to the LexA DNA binding domain. The $\tau 1$ -core was amplified by PCR as a *Sac*I fragment by using primers with the sequences 5'-GGCGAGCTCTGACCAA GCACCTTTGACAT-3' and 5'-GGGGAGCTCGCTCCTCATTCTGAGTTTC TTCCAA-3'. Mutated $\tau 1$ -core and $\tau 1$ proteins were also expressed by using this plasmid. Plasmid pRS315-NX expresses the full-length GR (residues 1 to 777) (44) (gift from Ulrika Lind, Department of Medical Nutrition, Karolinska Institute). The pLGZ-LexA reporter contains a single *E. coli* LexA repressor binding site (8) cloned into the *Xho*I site of pLGZ (76). The reporter gene consists of a basal *CYC1* promoter fused to the *lacZ* gene and is activated by proteins binding to the LexA binding site. The plasmids used in transient transfections were constructed by using two approaches. The nucleotide sequences encoding wild-type and mutant $\tau 1$ and $\tau 1$ -core proteins were amplified by PCR using Vent DNA polymerase (New England Biolabs) as *Bgl*II-cleavable fragments from pRS315- $\tau 1$ -LexA and pRS315- $\tau 1$ -core-LexA, respectively. Alternatively, mutant $\tau 1$ fragments were produced by *Bgl*II cleavage of mutagenized pRS315-NX. The $\tau 1$ domains were cloned into a derivative of pCMV-hGR α from which a *Bgl*II fragment encoding $\tau 1$ had been deleted. pCMV-hGR α (gift from Katrin Hecht, Department of Medical Nutrition, Karolinska Institute) expresses the intact human GR protein from the cytomegalovirus promoter. $\tau 1$ -core fragments containing a Kozak ATG start codon inserted N terminal of $\tau 1$ -core were cloned into a derivative of pCMV4 (2) that contains the GR DNA binding domain (residues 370 to 500) downstream of the cytomegalovirus pro-

moter. The mammalian reporter plasmid p19luc-TK (gift from Paul T. van der Saag, Hubrecht Laboratory, Netherlands Institute for Developmental Biology) is a modified version of pG29LtkCAT (62) containing two GREs upstream of a truncated thymidine kinase (TK) promoter linked to the luciferase firefly gene. The MTV-LUC reporter plasmid contains the mouse mammary tumor virus long terminal repeat linked to the luciferase firefly gene (31) and was a gift from Thomas Perlman (Ludwig Institute for Cancer Research, Stockholm, Sweden).

Mutagenesis and screening. Single-stranded phagemids pRS315-NX, pRS315- $\tau 1$ -LexA, and pRS315- $\tau 1$ -core-LexA were used as substrates for oligonucleotide-directed in vitro mutagenesis by the method of Kunkel et al. (39, 48). Mutagenesis of pRS315- $\tau 1$ -core-LexA was performed on the nucleotide sequences encoding amino acids 189 to 200 (helical region I), 205 to 216 (loop region), 217 to 228 (helical region II), or 234 to 241 (helical region III) of the $\tau 1$ -core, using primers synthesized with 3.5% contamination of each noncognate deoxynucleoside triphosphate at the first position of each codon predominantly, giving rise to one to two amino acid changes per molecule. Mutated plasmids from the various mutagenesis reactions were transformed by electroporation into *E. coli*, and plasmid DNA was isolated from pools of bacterial colonies (Wizard miniprep; Promega). To reduce the background frequency of nonmutated plasmids, the mutagenesis reactions were carried out on a single-stranded template containing a unique *Stu*I site incorporated into the mutated region. Incorporation of these sites did not result in reduced transactivation activity of the $\tau 1$ -core. *Stu*I digestion prior to transformation into *E. coli* reduced the background of nonmutated plasmids.

The plasmid pools were transformed into *S. cerevisiae* FY 24 (*MATa ura3-52 trp1- Δ 63 leu2- Δ 1 GAL⁺*; gift from Fred Winston, Harvard Medical School) containing the reporter plasmid pLGZ-LexA by the method of Gietz and Schiestl (24, 59). The ability of each of the mutant $\tau 1$ -core proteins to induce expression of β -galactosidase from the pLGZ-LexA reporter was tested in a 5-bromo-4-chloro-3-indolyl- β -D-galactopyranoside (X-Gal) plate assay. Six hundred fifty yeast colonies from each transformation were screened on minimal plates lacking leucine and uracil and containing 2% galactose and X-Gal (American Biorganics Inc.). The blue color of the yeast strains was compared to that of a strain expressing wild-type $\tau 1$ -core-LexA protein. Yeast strains with altered blue color were selected and rescreened.

Identification of mutations and β -galactosidase assay in yeast. Selected strains were grown on minimal plates containing 5-fluoro-orotic acid (1 μ g/ml; American Biorganics) to select for cells that had lost the reporter plasmid and facilitate isolation of the expression plasmids by transformation of *E. coli* with yeast DNA (74). $\tau 1$ -core-LexA plasmid DNA was isolated, and mutations were identified by DNA sequencing of the entire $\tau 1$ -core insert. Plasmids containing mutant $\tau 1$ -core-LexA were retransformed into yeast carrying the pLGZ-LexA reporter plasmid; the yeast strains were retested on X-Gal plates, grown in minimal medium lacking leucine and uracil, containing 2% galactose to induce expression of $\tau 1$ -core-LexA protein, for 18 to 24 h to an A_{600} of 0.2 to 0.3, and assayed for β -galactosidase activity as previously described (76).

Immunoblotting. Whole-cell yeast extracts were prepared by resuspending equal numbers of cells in sodium dodecyl sulfate (SDS) sample buffer (33). Extracts were subjected to denaturing polyacrylamide gel electrophoresis (PAGE) and transferred to nitrocellulose filters (Amersham) (9). Filters were blocked with 5% milk powder in phosphate-buffered saline (PBS) containing 0.5% Tween 80 and incubated with a rabbit polyclonal antibody raised against the *E. coli* LexA repressor DNA binding domain (kindly provided by Erica Golemis, Fox Chase Cancer Center, Philadelphia, Pa.) in PBS containing 0.5% Tween 80 for 60 min at room temperature. After washing, the filters were incubated with horseradish peroxidase-linked donkey anti-rabbit immunoglobulin G antibody (Amersham) at a dilution of 1:4,000 in PBS containing 0.5% Tween 80 for 60 min. After washing, the blots were developed by using an enhanced chemiluminescence system (Amersham).

Transient transfections of mammalian COS-7 cells. Transfections, culturing of cells, and luciferase assays were performed as described previously (1). Cotransfections using the p19luc-TK reporter were performed with nonsaturating amounts (0.3 μ g) of expression plasmid together with 5 μ g of reporter plasmid. Cotransfections using the MTV-LUC reporter were performed with 0.2 μ g of expression plasmid together with 5 μ g of reporter plasmid. Whole-cell extracts were prepared for immunoblot analysis as previously described (45, 75), with minor modifications. Briefly, COS-7 cells were transfected with expression vectors (6 μ g) and DOTAP (30 μ g; Boehringer) in 60- by 10-mm dishes for a period of 12 h, followed by incubation in fresh medium for 12 h. After a second transfection, cells were incubated in fresh medium for 6 h. Equivalent amounts of total protein from each whole-cell extract of GR derivatives and $\tau 1$ -core derivatives were separated by SDS-PAGE on 7.5 and 20% polyacrylamide gels, respectively, and transferred to nitrocellulose filters (Amersham). GR and GR mutant proteins were detected with a polyclonal anti-rabbit GR antibody (Affinity Bioreagents). Fusion proteins containing the $\tau 1$ -core and the GR DNA binding domain were detected with a monoclonal antibody directed against the GR DNA binding domain (1 μ g/ml; kindly provided by Ann-Charlotte Wikström and Marika Rönholm, Department of Medical Nutrition, Karolinska Institute).

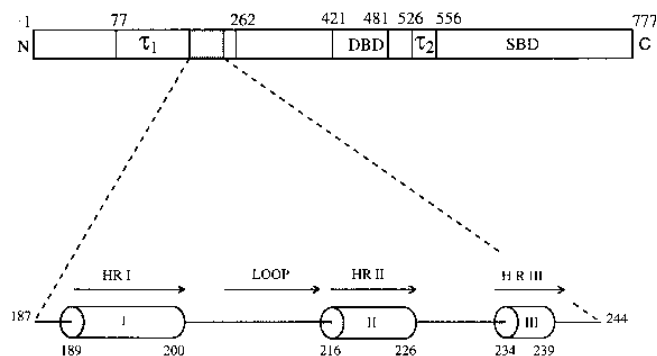

FIG. 1. Schematic representation of the τ 1-core transactivation domain of the human GR. The locations of segments with propensity for α -helical conformation identified by NMR are shown (helical regions [HR] I to III), and regions subjected to mutagenesis are indicated by arrows. τ 1 and τ 2 transactivation domains and the DNA binding domain (DBD) and the steroid binding domain (SBD) of the GR are indicated. The τ 1-core is indicated by a shaded box.

RESULTS

Experimental approach. To identify the amino acid residues that are most important for the transcriptional activation activity of the τ 1-core, we created pools of semirandomly mutated clones and screened for τ 1-core mutants with reduced and increased activity in yeast. Mutant τ 1-core proteins fused to the LexA DNA binding domain were screened in yeast cells by using a LexA-responsive *lacZ* reporter gene. Mutant clones with altered activity were detected by changes in the blue color of colonies grown on plates containing X-Gal. Plasmids encoding potentially interesting mutants were isolated from bacteria, and the nucleotide changes were identified by DNA sequencing. The plasmids were also retransformed into yeast to confirm the phenotype and to quantitate the effects of mutations by using β -galactosidase assays. Based on the results of screening experiments, further mutants were created by conventional oligonucleotide-directed mutagenesis to address specific questions. In addition, selected mutants were tested in mammalian cells and in the context of the intact GR to determine the significance of the results generated in yeast in a more physiological context.

Mutations were generated in a phagemid vector that expresses the τ 1-core-LexA fusion protein, using oligonucleotides corresponding to either of the three putative helical segments or the putative loop region (Fig. 1). Nucleotides corresponding to the first position of each amino acid codon were randomized, since this generally yields substitutions that result in amino acid changes which tend to be relatively conservative substitutions of the original residue. The level of contaminating deoxynucleotides required to introduce an average of one to two substitutions per oligonucleotide was determined empirically. Sequencing of clones chosen randomly from mutant pools, prior to screening, indicated that about 25% of the clones were mutated. About 650 clones were screened for each of the mutated regions.

Selection and quantitative analysis of mutants with reduced and increased transactivation activity and further mutational analysis of important residues. Screenings were performed on four regions of the τ 1-core (Fig. 1). In general, we found the expected frequency of single and double amino acid substitutions, and they corresponded to substitutions predicted from the design of the mutagenic primers. Based on the results of the X-Gal plate assay, we then selected the most interesting mutants (mainly single-substitution mutants) for quantitative

TABLE 1. Relative β -galactosidase activities of τ 1-core mutants

Mutant	Activity ^a	Mutant	Activity ^a
Helical region I		Helical region II	
T190P ^b	61 ± 4	E221F ^c	288 ± 15
F191I	38 ± 10	C223G	60 ± 3
F191V	48 ± 6	C223R	68 ± 5
F191L	57 ± 11	L225F ^c	174 ± 17
F191A ^c	44 ± 3	L225I	87 ± 6
F191E ^c	29 ± 3	L225V	83 ± 10
F191D ^c	28 ± 3	L218V/L219V ^c	60 ± 8
D192Y/I193V	36 ± 8	N222D/L225F	48 ± 7
I193F	151 ± 9	L224V/L225V	28 ± 3
I193L	42 ± 7	L224V/L225F	36 ± 8
I193A ^c	32 ± 2		
I193D ^c	27 ± 8	Helical region III	
L194V	23 ± 2	D233Y	72 ± 11
L194A ^c	19 ± 6	F235L/L236V	11 ± 2
Q195E ^c	68 ± 5	F235V/L236I	29 ± 9
D196Y	281 ± 26	L236V	17 ± 2
L197V	42 ± 7	L236F	62 ± 1
L197E ^c	30 ± 1	E238K/N240D	39 ± 2
E198Q	61 ± 1	G239R/N240D	24 ± 5
F199V	49 ± 3		
F199E ^c	34 ± 8		
S200P ^b	100 ± 10		
Loop			
E211K	47 ± 17		
W213G	42 ± 1		
W213R	30 ± 2		
W213A ^c	44 ± 5		
W213F ^c	78 ± 5		
W213Y ^c	117 ± 25		

^a Mean relative β -galactosidase activity (percentage of wild-type level ± standard deviation ($n = 3$)).

^b τ 1-core mutant found by sequencing the mutant pool prior to screening.

^c τ 1-core mutant made by site-directed mutagenesis.

analysis of their transactivation activities by using β -galactosidase assays of protein extracts prepared from cells grown in liquid culture. Furthermore, the most important residues identified in the screen were analyzed in more detail by measuring the activity of additional substitution mutants created by site-directed mutagenesis. The results of the β -galactosidase assays are shown in Table 1. The expression levels and stability of the mutant proteins were analyzed by immunoblot analysis (see Fig. 3).

As an example of the previous screening results, the data for helical region I are summarized in Fig. 2. In this screen, 38 clones with altered phenotype were identified and sequenced. Mutants were assigned to one of three classes based on their X-Gal activities in the plate assay. The most dramatic phenotype is represented by five mutants resulting in white colonies. Three of these resulted from stop codons or single base pair deletions (Fig. 2 and data not shown), leading to the expression of truncated proteins that do not have the LexA DNA binding domain. Two resulted from highly mutated clones with more than four amino acid substitutions. Twenty-three mutants exhibited a reduced activity. Most of these mutants had single or double amino acid substitutions at any of the five hydrophobic residues at positions Phe-191, Ile-193, Leu-194, Leu-197, and Phe-199. None of these point mutations resulted in a decrease in the expression level of the τ 1-core protein (Fig. 3); thus, each of these five hydrophobic residues appear to contribute to τ 1-core activity. Although the amino acid substitutions in these mutants are rather conservative, most of these mutant τ 1-core

Activity	DQSTFDILQDLEFSSG	Frequency
Inactive*	2
<WT	..L.....	2
	..I.....	1
	..V.....	1
L.....	1
V.....	3
E.....	1
V.....	3
Q.....	1
L.....	1
V..T	1
	..YV.....	1
	..H.....V..	1
VM.....	1
V.....L..	1
V..M..L..	1
	..H.....VP	1
	R..I.....A	1
	R..I.....V..	1
>WTF.....	7
	R...F.....	1
Y.....	1
Y...A	1

FIG. 2. Mutational analysis of helical region I of the τ 1-core. The possible amino acid substitutions that could arise in the mutagenesis are shown above the helical region I sequence. Stop codons are indicated by asterisks. Mutants were classified into three classes based on the X-Gal plate assay (inactive, reduced activity [less than wild-type activity (<WT)], and increased activity [>WT]). The amino acid substitutions identified by sequencing and the frequency of their occurrence are shown. Point deletions and very heavily mutated proteins are not indicated.

proteins were less than 50% as active as the wild-type τ 1-core. To test whether hydrophobicity correlates with activity, we constructed mutants with alanine and/or acidic residue substitutions at these five positions (Table 1). The activity of each of the alanine substitution mutants was as low as or lower than that of the least active hydrophobic substitution of the same residue. Introduction of acidic side chains by substitution with aspartic acid and glutamic acid residues had an even more severe effect, with activities between 20 and 30% of the wild-type activity. Mutations at position Leu-194 resulted in a greater reduction in activity than substitutions at any of the other four hydrophobic residues (Table 1, L194V and L194A). Generally, single amino acid substitutions of nonhydrophobic residues resulted in a less severe reduction in activity. Two clones with substitutions at positions Gln-195 and Glu-198 were isolated. Introduction or removal of acidic amino acids at these positions reduced the activity to 60 to 70% (Table 1, Q195E and E198Q). Proline substitutions at each end of helical region I (T190P and S200P) were identified among clones sequenced at random to evaluate the efficiency of the mutagenesis. From their locations, neither mutation would be expected to seriously perturb the bulk of helical region I, thereby reducing activity. However, the activity of T190P is reduced, probably due to interference of the proline residue at this position. In this regard, it should be noted that helical conformation could extend somewhat beyond the helical regions identified previously (15). In this respect, it is also possible that the important hydrophobic residue, Trp-213 in the loop region (see below), actually resides at the N-terminal end of helical region II. It has been noted that proline residues that are found

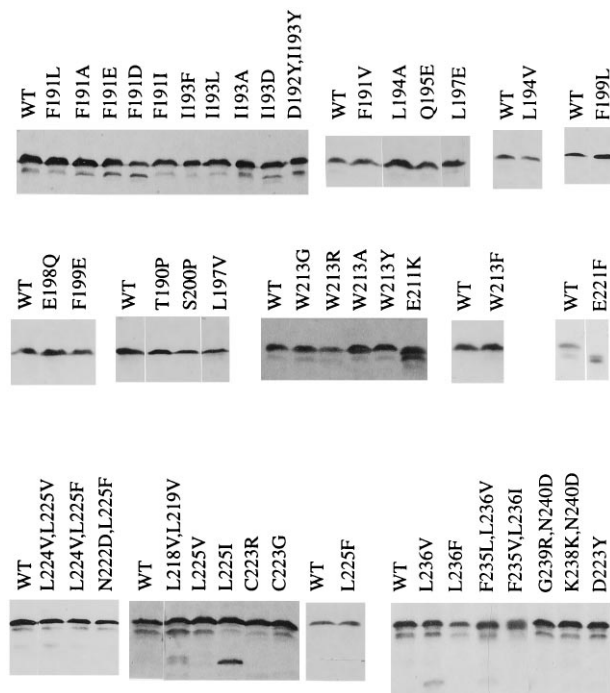

FIG. 3. Representative immunoblot analysis of wild-type (WT) and mutant τ 1-core-LexA proteins expressed in yeast. Aliquots containing equivalent amounts of protein from whole-cell extracts were separated by SDS-PAGE (20% gel) and transferred to nitrocellulose filters. The τ 1-core-LexA fusion proteins were detected with an anti-LexA antiserum. Expression levels of mutants should be compared to the wild-type sample on the same gel. No reproducible differences were seen in the stability of most mutant proteins compared to the wild type. However, E211K, L218V/L219V, L225I, E221F, and F235V/L236I consistently showed indications of reduced stability in protein extracts.

in the homologous regions of GR from other species invariably lie outside the helical regions that have been identified (15, 16). In addition, 10 transformants with increased activity were identified in the screen. These mutants had substitutions at either Ile-193 or Asp-196 and are discussed further below.

The number of mutant clones found in the putative loop region was much lower than the number found in helical region I. Analogous to the helical region I screening, white colonies occurred due to the expression of truncated proteins. Three single amino acid substitutions with reduced activity, occurring at two positions only (E211K, W213G, and W213R), were isolated. Single and double mutations containing substitutions at position Trp-213 were common and resulted in the most severe phenotype (Table 1 and data not shown). To characterize the importance of Trp-213, we made additional substitutions with alanine, tyrosine, and phenylalanine. Substitution with alanine caused a reduction in activity comparable to that seen in W213G. The activity of the W213Y and W213F mutants indicated that related hydrophobic residues could substitute completely or in part for tryptophan at this position (Table 1, W213Y and W213F). The mutation affecting a charged residue, E211K, is only 47% active. However, this may be a consequence of reduced protein stability leading to partial degradation as seen in the immunoblot analysis (Fig. 3, E211K). Double mutation of charged residues (K206E/D216T) had a less severe effect, and mutations such as S211R, S216P, and P212S/D216Y were almost as active as the wild-type protein (data not shown).

Single amino acid substitutions in helical region II (Table 1, L225I and L225V) caused only a mild reduction in activity, and

it appeared to be necessary to substitute at least two amino acids (where at least one was hydrophobic) (Table 1, N222D/L225F, L224V/L225V, and L224V/L225F) to produce effects similar in strength to those caused by single changes in helical region I. The distribution of mutants found in helical region II was not completely uniform; thus, no single and double amino acid substitutions were isolated between residues 217 and 221 even though this segment contains hydrophobic residues. To test whether these residues have importance for τ 1-core activity, we constructed a double-substitution mutant (L218V/L219V) that is analogous to the double mutants involving residues 224 and 225 that were found in the screen. The activity of L218V/L219V was not as greatly reduced (Table 1; compare with L224V/L225V), and thus we conclude that Leu-218 and Leu-219 are probably less important for τ 1-core activity than Leu-224 and Leu-225. Interestingly, a decrease in activity resulted from substitutions at Cys-223 in helical region II (Table 1, C223G and C223R). This cysteine residue could potentially be involved in the formation of disulfide bridges, but it should be noted that this residue is deleted from the equivalent regions of the rat and mouse receptors, which are otherwise highly similar to the human sequence. As in helical region I, only a few mutants (e.g., L225F/P227S and L225F/P227S/L228M) resulted in increased activity (data not shown). L225F is common to these two mutants, and when constructed individually, the L225F mutant was shown to have increased activity (Table 1).

Single amino acid substitutions in helical region III (Table 1, D233Y and L236F) appeared to cause a relatively small decrease in activity. The only exception is L236V, which displayed a substantially reduced activity (Table 1). Double substitution mutations with substantially reduced activity (Table 1, E238K/N240D, F235V/L236I, F235L/L236V, and G239R/N240D) were also isolated, suggesting that in general, double amino acid substitutions are required in helical region III to substantially reduce activity.

Alanine substitutions of hydrophobic residues within helical regions. The mutagenesis results show that hydrophobic residues within the helical segments of the τ 1-core play a critical role during transcriptional activation and that helical region I appears to be the most important of the helical regions. To further investigate the role of hydrophobic amino acids in the various helical regions of the τ 1-core, we constructed mutants containing alanine substitutions of all hydrophobic amino acids in helical region I, II, or III (Fig. 4A). The activities of the mutated helices were tested in yeast, either singly or in combination (Fig. 4B). As suggested by the initial results, the most severe phenotype was associated with mutation of hydrophobic amino acids in helical region I (H1ala). This mutant retains only 7% of wild-type activity. The mutant affecting helical region II (H2ala) had a somewhat higher residual activity (18%), while the mutant affecting helical region III (H3ala) displayed wild-type activity. The combined mutant (H1,2ala) was reduced to basal levels (4%). The expression levels of all of the alanine substitution mutants were similar to that of the wild-type protein (Fig. 4C), and thus the reductions in β -galactosidase activity can be attributed to changes in the activity of τ 1-core. Removal of the side chains from the hydrophobic residues in helical region III by substitution with alanine (H3ala) did not result in a reduced transactivation activity. This was surprising since the substitution mutations in the same residues (e.g., L236V and F235L/L236V [Table 1]) that were identified in the screen displayed reduced τ 1-core activity. Since the expression levels of the proteins were not significantly influenced by any of the mutations, it is likely that the defects caused by the mutations identified in the screen were

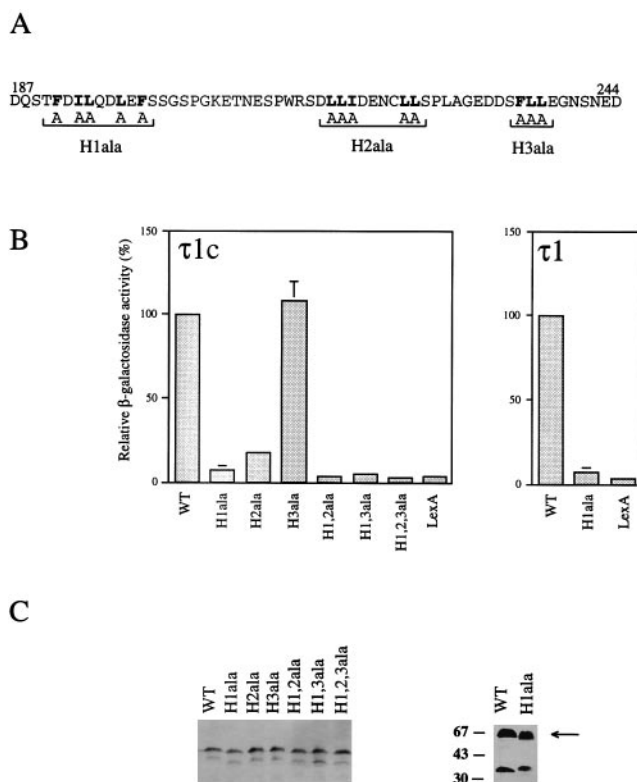

FIG. 4. (A) Amino acid sequence of the τ 1-core domain, showing the locations of alanine substitution mutants in helical regions I (H1ala), II (H2ala), and III (H3ala). The residues that were substituted with alanines are shown in boldface. These mutations were introduced both individually and in combination. (B) Transactivation activities of alanine substitution mutants in the context of τ 1-core (τ 1c) or τ 1 domain (τ 1) in yeast. The relative transactivation activities of both individual and combined alanine substitution mutants in the context of the τ 1-core peptide (left) and the τ 1 domain (right) are shown. Transactivation activity is expressed as a percentage of wild-type (WT) activity. The LexA DNA binding domain alone (LexA) was included as a negative control. The mean β -galactosidase activity from three independent experiments is shown for each mutant, and the error bars represent the standard deviation in each case. (C) Immunoblot analysis expression levels of alanine substitution mutants in the τ 1-core and the τ 1 domain. The migration of the τ 1-LexA protein is indicated by an arrow. Equivalent amounts of total protein were loaded in all lanes. Sizes are indicated in kilodaltons.

due to a property of the substituted amino acid side chains rather than loss of the original side chains.

To study the significance of these results for the activity of the intact τ 1 domain, we transferred the H1ala mutation into the intact τ 1 domain and showed that it had a similarly dramatic effect on activity (Fig. 4B). This result supports and extends our previous conclusion, based on deletion analysis, that the τ 1-core represents the only autonomous transactivation domain within the τ 1 fragment (14).

Hydrophobic residues in helical regions I and II are important for the activity of τ 1-core and the full-length GR in mammalian cells. Hydrophobic residues in helical regions I and II appear to be important for the activity of τ 1-core in yeast cells. To test whether this was also true for mammalian cells, we expressed mutant τ 1-core domains fused to the GR DNA binding domain in COS-7 cells. Figure 5A shows that the wild-type τ 1-core protein, originally identified as an active core region in yeast cells, is also functional in mammalian cells and that the H1,2ala mutation reduced its activity to background levels comparable to the activity of the empty expression vector. As in yeast, the reduced activity of the mutant protein

could not be attributed to reduced stability of the expressed protein (Fig. 5E). Thus, the same set of residues are of critical importance for the activity of the $\tau 1$ -core in both yeast and mammalian cells.

To study the role of the $\tau 1$ -core helical regions in the context of the intact GR, we introduced the H1ala and H1,2ala mutations together with a deletion of the entire $\tau 1$ domain into vectors designed for expression of the intact GR in mammalian cells. Deletion of the $\tau 1$ domain from the full-length GR protein resulted in decreased transactivation of a $(\text{GRE})_2$ -TK-luciferase (LUC) reporter gene to 24% of the wild-type level (Fig. 5B). The residual activity measured can probably be attributed to the other transactivation activities that are present in the hormone binding domain of the receptor (see the introduction). The H1ala and H1,2ala mutations reduced activity to 60 and 38% of the wild-type value, respectively (Fig. 5B), and the stabilities of the expressed proteins were similar (Fig. 5E). We conclude that the hydrophobic residues in the two helical regions make important contributions to the transactivation activity of the intact GR. However, in the complicated context of the intact receptor protein, the residual activity of the mutants relative to the $\tau 1$ deletion construct was somewhat greater than for the equivalent mutants in the context of the isolated $\tau 1$ -core relative to basal transcription levels. This may reflect synergistic interactions between the receptor transactivation domains that reduce the sensitivity of the protein to mutations in any single transactivation domain.

Next we wished to determine whether single and double amino acid substitutions that affected the activities of $\tau 1$ -core-LexA fusion proteins in yeast would have similar effects in the context of the intact GR in mammalian cells. Since other activities in the receptor protein partly compensate for defects in $\tau 1$ -core (Fig. 5A and B), we used a reporter gene containing the mouse mammary tumor virus promoter because its activation by the GR is predominantly dependent on the $\tau 1$ domain (31). The results in Fig. 5C confirm that the $\Delta\tau 1$, H1ala, and H1,2ala mutations cause somewhat stronger defects for activation of this promoter compared to the $(\text{GRE})_2$ -TK promoter (Fig. 5B). Selected single amino acid substitution mutants in helical region I and the postulated loop region that caused reductions in the activity of $\tau 1$ -core-LexA fusion proteins in yeast (19 to 34% active) also reduced the activity of the intact receptor in mammalian cells (64 to 77% active) (Fig. 5C). The double substitutions, N222D/L225F and L224V/L225F, in helical region II that reduced activity of $\tau 1$ -core-LexA fusion proteins to 48 and 36%, respectively, did not cause a reduction in the activity of the intact GR. Thus, it is possible that these residues do not play a role in transactivation by the intact receptor protein. However, three of the five alanine substitutions in the H2ala mutation, which does cause a defect in the intact receptor context (Fig. 5B and C), affect the same residues (N222, L224, and L225). Thus, it is more likely that these helical region II residues play a less important role in the intact protein compared to similar residues in helical region I and the loop region, which is more easily compensated for by other transactivation activities within the intact receptor protein. To further compare the functions of $\tau 1$ -core residues in the context of LexA fusion proteins in yeast with their roles within the intact receptor protein in mammalian cells, we studied two mutants (I193F and E221F) that increased the activity of $\tau 1$ -core-LexA in yeast (151 and 288% active, respectively). In the intact GR context, I193F and E221F caused smaller increases in activity (111% and 179% active, respectively [Fig. 5D]); thus, as for most reduced-activity mutations, the increased-activity mutations caused effects similar to those in the fusion protein context, but the magnitude of the changes was lower.

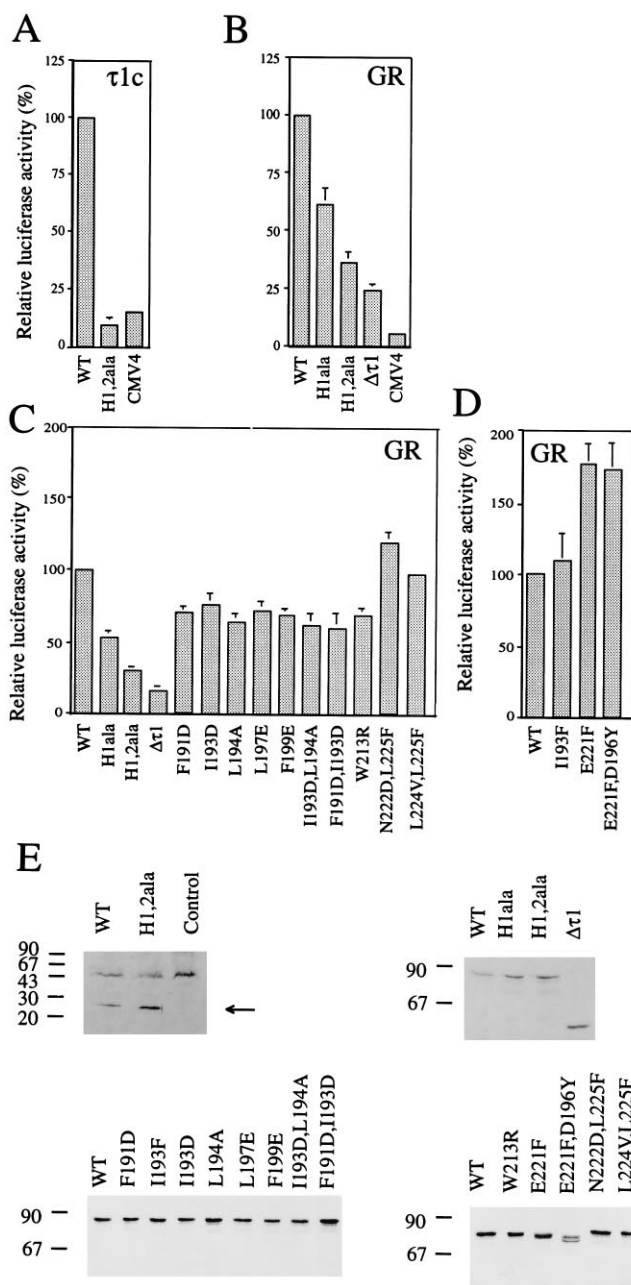

FIG. 5. Transactivation activities of hydrophobic mutants in the context of the $\tau 1$ -core and the intact GR in COS-7 cells. (A) Activation of transcription from the $(\text{GRE})_2$ -TK-LUC (p19luc-TK) reporter by alanine substitution mutants in the $\tau 1$ -core is shown as the mean (\pm standard deviation) of three independent experiments. Activities are expressed relative to that of the wild-type (WT) protein. CMV4 is the empty vector control. (B) Transactivation activities of alanine substitutions in the context of the intact GR from the GR-responsive $(\text{GRE})_2$ -TK-LUC reporter in the presence of $1 \mu\text{M}$ dexamethasone. The data are presented as in panel A. (C) Transactivation activities of a selection of GR mutants, using the MTV-LUC reporter. These mutations give rise to a reduced activity in the context of the $\tau 1$ -core. The data are presented as in panel B. (D) Transactivation activities of GR mutants that cause increased activity in the context of the $\tau 1$ -core. (E) Immunoblot analysis of whole-cell extracts of $\tau 1$ -core and GR mutant and wild-type proteins. Equivalent amounts of total protein were loaded in all lanes. The migration of the $\tau 1$ -core GR DNA-binding-domain proteins are indicated by an arrow. Control, extract prepared from nontransfected cells. Sizes are indicated in kilodaltons.

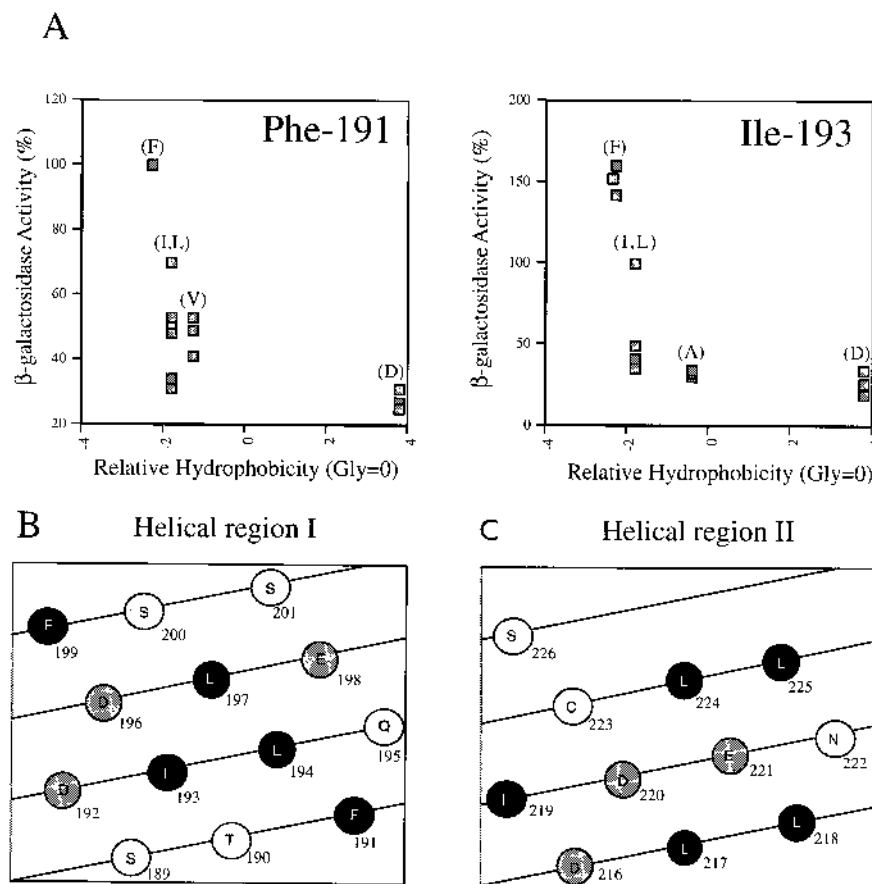

FIG. 6. (A) Relative transactivation activities of τ 1-core mutants of Phe-191 (left) and Ile-193 (right) in yeast in relation to the hydrophobicity of the substituting amino acids. The hydrophobicity of amino acids relative to glycine has been calculated previously (53). The data presented for each mutant (marked by the substituting amino acid, F, L, I, V, A, or D) is shown as relative β -galactosidase activity (wild-type activity = 100%) obtained in three independent experiments. (B) Amino acid sequence of helical region I in the τ 1-core plotted on the surface of an α -helix. Hydrophobic residues are black, and acidic residues are shaded. (C) The amino acid sequence of helical region II in the τ 1-core shown as described for panel B.

Interestingly, E221 is localized within helical region II, suggesting that this region plays a role even in the intact receptor context. Combination of E221F with a second increased-activity mutation (D196Y) did not further increase the activity of the GR (Fig. 5D). The Western blot in Fig. 5E shows that the mutations studied here do not seriously affect the stability of the GR protein.

Relationship between hydrophobicity and transcriptional activation activity. The identification of several different hydrophobic residues as important for transcriptional activation suggested that there might be a relationship between hydrophobicity and activity. Such a relationship is seen qualitatively at several residues where less hydrophobic substitutions have reduced activity (Table 1). This was investigated in more detail as shown in Fig. 6A, where the activities of different substitutions of residues 191 and 193 in helical region I are plotted as a function of the hydrophobicity of the substituting amino acids. The results show that while the activity of each of the different proteins is not directly proportional to the hydrophobicity of the substituting residues, there is a progressive drop in activity as the hydrophobicity of the substituting residues falls. This relationship is not associated only with loss-of-function mutants, since the I193F mutant, which increased the hydrophobicity of residue 193, also increased the activity of the τ 1-core to 150% of the wild-type level.

When considered in the context of an α -helix, four of the five

hydrophobic residues in helical region I cluster as a hydrophobic patch on the surface of the α -helix (Fig. 6B). In addition to the I193F mutant, a second mutant (D196Y) was identified in the screen as an increased-activity mutant with almost three times the activity of the wild-type protein. Interestingly, a hydrophobic residue at this position extends the hydrophobic patch to include both the new tyrosine residue at position 196 and Phe-199 (Fig. 6B). These results suggest a model where the hydrophobicity and size of hydrophobic patches is related to transactivation activity. Consistent with this model, increased-activity mutants (E221F and L225F) which either extend the hydrophobic patch or increase hydrophobicity can also be found in helical region II (Fig. 6C). Interestingly, the most potent activating mutant in helical region II (E221F [Table 1]) increases activity almost threefold and, similar to the activating D196Y mutant in helical region I, replaces an acidic residue and increases the size of the hydrophobic patch. In summary, these results suggest the possibility of a direct relationship between the hydrophobicity and size of hydrophobic patches and transactivation activity.

To test this model, we mutated nonhydrophobic residues adjacent to the hydrophobic patch of helical region I (Thr-190 and Asp-192) to phenylalanine and tyrosine. Figure 7A shows that mutations at position Thr-190 resulted in an increased transactivation activity compared to the wild-type τ 1-core. These results show that it is possible to increase the τ 1-core

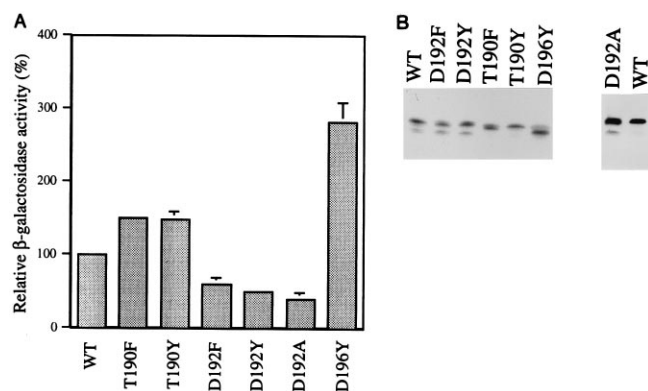

FIG. 7. (A) Relative transactivation activities of mutant τ 1-core proteins that increase the hydrophobic character in helical region I. The data are presented as in Fig. 4B. (B) Immunoblot analysis of wild-type (WT) and mutant τ 1-core protein expressed in yeast cells. The data are presented as in Fig. 3.

activity by increasing the size of the hydrophobic patch by mutating residues other than Asp-196. In contrast, similar substitutions of Asp-192 reduced activity to 50% of that of the wild-type τ 1-core. All of the proteins studied were expressed at similar levels (Fig. 7B). Phenylalanine and tyrosine residues contain bulky hydrophobic side chains that may give rise to steric hindrance effects leading to a reduced activity. To investigate the role of Asp-192 further, we substituted it with alanine (D192A). This mutant also showed a reduced-activity phenotype (Fig. 7A). We conclude that the presence of an acidic side chain at residue 192 is important for full activity. Thus, although the hydrophobicity of hydrophobic patches on α -helices appears to be an important aspect of τ 1-core activity, there are clearly other components that are also important.

DISCUSSION

We have used a genetic screen in yeast to identify the amino acids that are most important for the transactivation activity of the τ 1 domain of the GR. The outcome of this screening clearly indicates the importance of hydrophobic amino acid residues. Our data are consistent with the finding that hydrophobic residues are important for the activity of the VP16 transactivation domain (13, 54). Subsequent to those initial studies, site-directed mutagenesis has implicated a role for hydrophobic residues in other transactivation domains from transcription factors such as Sp1 (26), RelA/p65 (5, 60), p53 (42), Gcn4 (18), and RAR β 2 (21). In studies on the VP16 and RelA transactivation domains, residues with bulky aromatic side chains were reported to be particularly important for the transactivation activities of these activators (5, 54). Phenylalanines are found at positions 191 and 199 in helical region I of the τ 1-core, but they do not contribute more to activity of the τ 1-core than any of the other three hydrophobic residues in this region (Table 1). In fact, mutations affecting Leu-194 result in the most severe reduction in transactivation activity (Table 1, helical region I; Fig. 5C). Thus, the observation that hydrophobic residues are important for the activities of several different transactivation domains does not necessarily mean that they all function via the same mechanism.

The τ 1-core is attractive as a model for the mechanism of transactivation domain function because the positions of segments with a propensity for α -helix formation have been localized experimentally. Interestingly, the cluster of five hydrophobic residues that seemed to be of predominant importance is

located within the most N terminal of these helical segments (helical region I). While Trp-213, residing in a postulated loop region between helical regions I and II, also appears to play an important role, the five hydrophobic residues in helical region II are less important for activity. For helical region III, our screening data indicated an important role for Leu-236 because mutations at this residue reduced the activity. However, when this residue and two adjacent hydrophobic residues were subsequently substituted by alanine residues, no reduction in the transactivation activity was observed. This result suggests that the side chain of Leu-236 is not important but that other side chains at this position are deleterious to activity even if they represent conservative changes (e.g., L236F and L236V). The sensitivity of the various regions to amino acid substitutions is in accordance with our original study in which the τ 1-core domain was localized by deletion analysis of the intact τ 1 domain. The borders of the minimal segment maintaining full activity were identified from N-terminal and C-terminal deletion analysis as Asp-187 and Pro-227 (excluding helical region III). However, the isolated segment encompassing residues 187 to 227 did not maintain full activity such that activity of this segment could be substantially increased by including amino acids 228 to 244, which include helical region III. It is likely that the segment between amino acids 187 and 227 needs structural elements from adjacent sequences for stability, and thus the role of helical region III could be to provide a stabilizing α -helix. This model correlates with the mutagenesis data because while substitution with alanine should stabilize the helix just as well as the normal residues, all of the reduced-activity mutants involving residues 235 and 236 would be predicted to form a less stable α -helix (53).

We have previously demonstrated that the acidity resulting from negatively charged side chains and phosphorylation is generally not important for transcriptional activity of the τ 1 domain. However, a τ 1 protein mutated at the four acidic residues Asp-187, Asp-192, Asp-196, and Glu-198 did show reduced activity (1). Interestingly, all of these residues except Asp-187 are located in the region recently identified as helical region I in the τ 1-core. In the present study, the activities of the D192A (Fig. 7) and E198Q (Table 1) mutants were reduced to 40 and 61% of the wild-type level, respectively, indicating that they both make individual contributions to activity. The third acidic residue (Asp-196) appears to be dispensable since the D196Y mutation exhibits increased activity (Table 1). The fact that several of the mutations in this study increase acidity but result in reduced activity confirms our previous conclusion that while specific acidic amino acids may play a role in transactivation activity, the acidity of most individual acidic residues is not critical for transactivation activity (1).

The approaches that we have taken during the delineation and mutagenesis of the τ 1-core rely on the assumption that basic mechanisms of gene activation are conserved between yeast and mammals. This view is supported by the apparent conservation of promoter structure and proteins constituting the transcriptional apparatus between different eukaryotic cells (28). Here we demonstrate that the τ 1-core domain of the GR, first identified as the core of the transactivation domain in yeast, is also a potent transactivation domain in mammalian cells. The level of activation obtained with the τ 1-core segment was similar to level measured for an analogous protein containing the intact τ 1 domain (data not shown). Furthermore, mutagenesis of hydrophobic amino acids that abolish the activity of the τ 1-core in yeast also abolish its function in COS-7 cells. Thus, for the GR, there appears to be a good correlation between the determinants required for transactivation in yeast and mammalian cells.

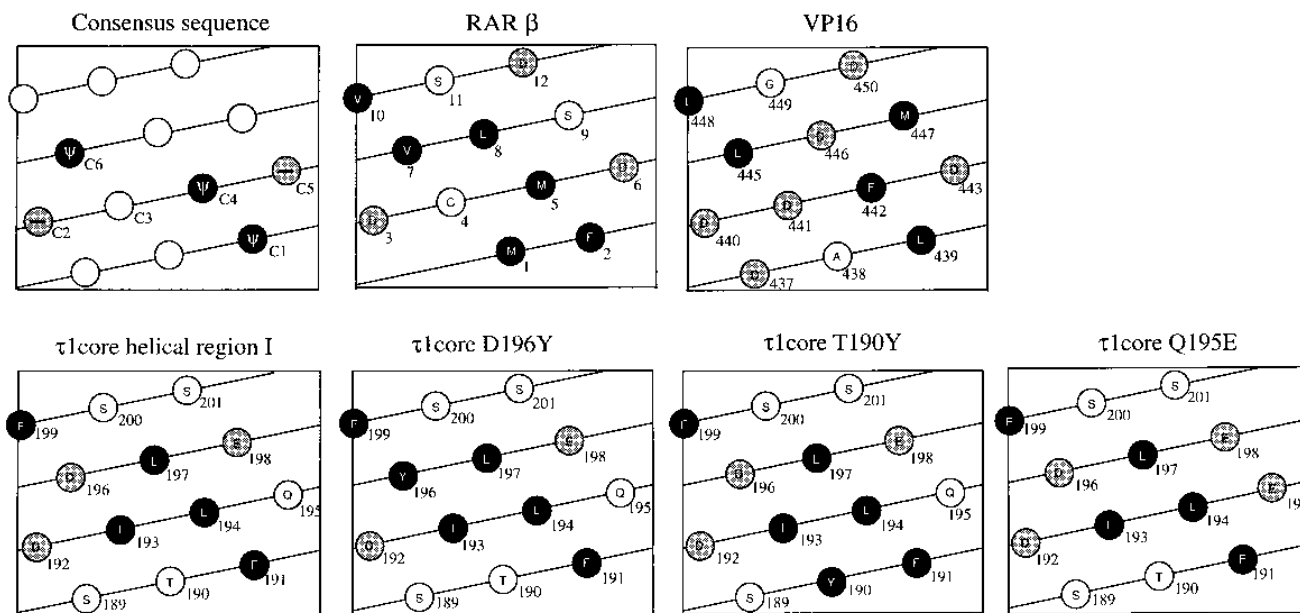

FIG. 8. Comparison of amino acids in τ 1-core helical region I with a consensus sequence for acidic transactivation domains. The amino acid sequences are presented as described for Fig. 6B. Hydrophobic residues are black, and acidic residues are shaded. The six positions in the consensus sequence are marked C1 to C6, where positions C1, C4, and C6 correspond hydrophobic/aromatic residues (Ψ) and positions C2 and C5 are acidic residues (—). The amino acid sequences of τ 1-core mutants D196Y, T190Y, and Q195E and regions important for transcriptional activation by RAR β 2 and VP16 are presented in the same way. Alternative alignments of the GR and RAR β 2 segments are also possible (e.g., with Met-1 of RAR β 2 equivalent to Ile-193 of the GR).

The hydrophobic amino acids in helical regions I and II are also key components for transactivation in the context of the intact GR in COS-7 cells. The H1,2ala mutant, including mutations at hydrophobic residues within helical regions I and II, is almost as inactive as the construct from which the τ 1 domain has been deleted. This construct still maintains a substantial activity due to the presence of the other transactivation domains. Although the alanine substitutions of hydrophobic residues have a substantial impact in the context of the intact GR, the residual level of activity is higher than was observed when the τ 1-core proteins were studied in isolation. This is most likely a consequence of synergism between the τ 1 domain and the other transactivation functions that augment the function of the compromised τ 1 domain in the intact GR context. In spite of this compensation phenomenon, all single amino acid substitutions tested that reduced or increased the activity of τ 1-core-LexA fusion proteins in yeast caused similar, albeit more modest, changes in the context of the intact GR in mammalian cells. Thus, the hydrophobic residues that have been identified must be involved in roles that are fundamentally important for the structure and/or function of the τ 1 domain in both yeast and mammalian cells.

Two non-mutually exclusive roles for the hydrophobic residues within the τ 1-core can be envisaged. They could represent the hydrophobic core of the τ 1 domain being important for the structural integrity of the protein; alternatively, they could represent one or more surfaces that interact with target proteins. Interestingly, structural studies of several purified transactivation domains have shown that they have a low propensity for secondary structure formation in aqueous solution (15, 60, 72). However, α -helical structure can be induced in transactivation domains from VP16 (71), RelA/p65 (60), τ 1-core (15), and c-Myc (50) by more hydrophobic solvents. Additionally, β -sheet structure was induced at low pH in the Gcn4 and Gal4 transactivation domains (72). These results suggest either that transactivation domains are unfolded when mediating their

effect of enhancing the rate of transcription or that they fold conditionally when directly involved in transcriptional activation, in which case transactivation domain folding per se could be a limiting factor during gene activation. Two recent studies using different approaches suggest that conformational changes may occur in transactivation domains during transactivation. First, fluorescence spectroscopy of the VP16 transactivation domain showed a more constrained structure in the presence of TBP (64). Second, interaction of the c-Myc transactivation domain with TBP results in a change in circular dichroism spectra, consistent with a conformational change in the c-Myc protein upon interaction with TBP (50). Our previous observation that several monoclonal antibodies, directed against the intact GR, recognize epitopes containing helical region I (49) indicates that this region is located at the surface of the receptor protein and is accessible for interactions with target factors.

Early models suggested that transactivation domains might function as unstructured domains in which general ionic properties were sufficient to recruit target factors via relatively nonspecific interactions (65). However, the mutagenesis data presented in this report are more consistent with a structural requirement for the τ 1 domain. Similar substitutions of charged residues (e.g., D192Y and D196Y) have opposite effects on activity which would be difficult to account for according to "unstructured" models but which can be readily rationalized in a structured context. Thus, while the overall acidity (1) and hydrophobicity of the τ 1-core domain are both important for the activity of τ 1, their role can be rationalized only within a structured transactivation domain context. For the τ 1-core domain, we are still not sure that the helical regions stabilized under hydrophobic conditions are also relevant for transactivation, but the observation that several proline substitution mutants reduce both helix-forming potential and transactivation activity (16) provides strong evidence that the helical regions play an important role.

It is unlikely that classifying transactivation domains according to their amino acid composition (acidic in the case of $\tau 1$) is a sufficient basis for attributing similar mechanisms of action to all classes. This has already been shown for the glutamine-rich class of transactivation domains, where different members have been reported to employ distinct mechanisms to achieve gene activation (58). Interestingly, helical region I of the $\tau 1$ -core shows some similarity to the transactivation domain of another nuclear receptor, retinoic acid receptor $\beta 2$ (RAR $\beta 2$) (Fig. 8). The similarity of this region in RAR $\beta 2$ to transactivation domains from a number of other proteins, including the VP16 and Rta proteins from herpes simplex virus and Epstein-Barr virus, was noted previously (21). The consensus motif deduced from that study is represented by a helical net presentation in Fig. 8. Residues at positions C1, C4, and C6 of this motif are generally hydrophobic, whereas positions C2 and C5 contain acidic residues. The nature of the amino acid at position C3 is not defined by the consensus motif. The character of each of the residues at positions 191 (Phe, C1), 192 (Asp, C2), and 194 (Leu, C4) of helical region I in the $\tau 1$ -core is consistent with this consensus. Furthermore, mutational studies of VP16 and RAR $\beta 2$ have shown that the hydrophobic residue corresponding to position C4 of the motif contributes most to transactivation activity (21, 54). Our data agree with this observation since the residue at this position in helical region I is Leu-194, which appears to be more important for the activity of the $\tau 1$ -core than the other hydrophobic residues (Table 1). Interestingly, the D196Y mutation, which gives rise to an increased activity, increases the match to the consensus motif (Fig. 8). However, the Q195E mutation, which also improves the consensus, does not lead to an increased activity, while the T190Y substitution, which increases activity, does not improve the match to the consensus motif (Fig. 8). In addition, other residues that lie outside the consensus motif (e.g., Ile-193) also play a key role. We suggest that this consensus motif may represent a common structural scaffold around which activator-specific features are incorporated. Not all acidic transactivation domains contain a close match to this consensus motif. One example is the transactivation domain of the RelA protein, but in this case, a distinct motif, consisting of two repeats containing three hydrophobic residues forming a triangular patch half surrounded by hydrophilic residues, has been reported (60). A second example is the transactivation domain of Gcn4, which was recently shown to contain multiple clusters of hydrophobic residues throughout its entire length (125 amino acids) (36). These clusters appear to be functionally redundant such that a critical number of clusters is required for full activity but no individual cluster is indispensable. Even though both the $\tau 1$ -core and Gcn4 activation domains contain critical hydrophobic amino acids, they appear to function differently, and this observation correlates with the observation that a segment of the Gcn4 activation domain has a propensity for β -sheet conformation (36). Taken together, these results suggest that it is possible to categorize acidic transactivation domains according to different motifs, but it remains to be seen to what extent each category employs a unique mechanism of transactivation.

ACKNOWLEDGMENTS

We thank members of the Steroid Receptor Unit at the Center for Biotechnology for helpful comments during this work, Zhila Hossingad for excellent technical assistance, Johan Lidén and Maria Lindero for help with mammalian immunoblot analysis techniques, Ann-Charlotte Wikström and Marika Rönnholm (Department of Medical Nutrition, Karolinska Institute) and Erica Golemis (Fox Chase Cancer Center, Philadelphia, Pa.) for generously providing the antibodies

raised against GR and LexA, respectively, Katrin Hecht (Department of Medical Nutrition, Karolinska Institute), Paul T. van der Saag (Hubrecht Laboratory, Institute for Developmental Biology, Utrecht, The Netherlands), Thomas Perlman (Ludwig Institute for Cancer Research, Stockholm, Sweden), and Ulrika Lind (Department of Medical Nutrition, Karolinska Institute) for generously providing plasmids, and Fred Winston (Harvard Medical School) for generously providing yeast strains. We also thank Johanna Zilliacus for helpful discussion during this work and Elizabeth Flinn and Karin Dahlman-Wright for critically reading the manuscript.

This work was supported by Swedish Medical Research Council grant 13x-2819 and Swedish Natural Science Research Council grant K-KV9756-301.

REFERENCES

- Almlöf, T., A. P. Wright, and J.-Å. Gustafsson. 1995. Role of acidic and phosphorylated residues in gene activation by the glucocorticoid receptor. *J. Biol. Chem.* **270**:17535-17540.
- Andersson, S., D. L. Davis, H. Dahlback, H. Jornvall, and D. W. Russell. 1989. Cloning, structure, and expression of the mitochondrial cytochrome P 450 sterol 26 hydroxylase, a bile acid biosynthetic enzyme. *J. Biol. Chem.* **264**:8222-8229.
- Baniahmad, A., I. Ha, D. Reinberg, S. Tsai, M. J. Tsai, and B. W. O'Malley. 1993. Interaction of human thyroid hormone receptor beta with transcription factor TFIIB may mediate target gene derepression and activation by thyroid hormone. *Proc. Natl. Acad. Sci. USA* **90**:8832-8836.
- Beato, M. 1991. Transcriptional control by nuclear receptors. *FASEB J.* **5**:2044-2051.
- Blair, W. S., H. P. Bogerd, S. J. Madore, and B. R. Cullen. 1994. Mutational analysis of the transcription activation domain of RelA: identification of a highly synergistic minimal acidic activation module. *Mol. Cell. Biol.* **14**:7226-7234.
- Blanco, J. C., I. M. Wang, S. Y. Tsai, M. J. Tsai, B. W. O'Malley, P. W. Jurutka, M. R. Haussler, and K. Ozato. 1995. Transcription factor TFIIB and the vitamin D receptor cooperatively activate ligand dependent transcription. *Proc. Natl. Acad. Sci. USA* **92**:1535-1539.
- Bodwell, J. E., E. Orti, J. M. Coull, D. J. Pappin, L. I. Smith, and F. Swift. 1991. Identification of phosphorylated sites in the mouse glucocorticoid receptor. *J. Biol. Chem.* **266**:7549-7555.
- Brent, R., and M. Ptashne. 1985. A bacterial repressor protein or a yeast transcriptional terminator can block upstream activation of a yeast gene. *Nature (London)* **314**:198.
- Burnette, W. N. 1981. "Western blotting": electrophoretic transfer of proteins from sodium dodecyl sulfate polyacrylamide gels to unmodified nitrocellulose and radiographic detection with antibody and radioiodinated protein A. *Anal. Biochem.* **112**:195-203.
- Cavaillès, V., S. Dauvois, P. S. Danielian, and M. G. Parker. 1994. Interaction of proteins with transcriptionally active estrogen receptors. *Proc. Natl. Acad. Sci. USA* **91**:10009-10013.
- Cavaillès, V., S. Dauvois, F. L'Horsset, G. Lopez, S. Hoare, P. J. Kushner, and M. G. Parker. 1995. Nuclear factor RIP140 modulates transcriptional activation by the estrogen receptor. *EMBO J.* **14**:3741-3751.
- Colgan, J., H. Ashali, and J. L. Manley. 1995. A direct interaction between a glutamine rich activator and the N terminus of TFIIB can mediate transcriptional activation *in vivo*. *Mol. Cell. Biol.* **15**:2311-2320.
- Cress, W. D., and S. J. Triezenberg. 1991. Critical structural elements of the VP16 transcriptional activation domain. *Science* **251**:87-90.
- Dahlman-Wright, K., T. Almlöf, I. J. McEwan, J.-Å. Gustafsson, and A. P. Wright. 1994. Delineation of a small region within the major transactivation domain of the human glucocorticoid receptor that mediates transactivation of gene expression. *Proc. Natl. Acad. Sci. USA* **91**:1619-1623.
- Dahlman-Wright, K., H. Baumann, I. J. McEwan, T. Almlöf, A. P. Wright, J.-Å. Gustafsson, and T. Härd. 1995. Structural characterization of a minimal functional transactivation domain from the human glucocorticoid receptor. *Proc. Natl. Acad. Sci. USA* **92**:1699-1703.
- Dahlman-Wright, K., and I. J. McEwan. 1996. Structural studies of mutant glucocorticoid receptor transactivation domains establish a link between transactivation activity *in vivo* and alpha helix forming potential *in vitro*. *Biochemistry* **35**:1323-1327.
- Danielian, P. S., R. White, J. A. Lees, and M. G. Parker. 1992. Identification of a conserved region required for hormone dependent transcriptional activation by steroid hormone receptors. *EMBO J.* **11**:1025-1033.
- Drysdale, C. M., E. Duenas, B. M. Jackson, U. Reusser, G. H. Braus, and A. G. Hinnebusch. 1995. The transcriptional activator GCN4 contains multiple activation domains that are critically dependent on hydrophobic amino acids. *Mol. Cell. Biol.* **15**:1220-1233.
- Eggert, M., C. C. Mows, D. Tripiet, R. Arnold, J. Michel, J. Nickel, S. Schmidt, M. Beato, and R. Renkawitz. 1995. A fraction enriched in a novel glucocorticoid receptor interacting protein stimulates receptor dependent transcription *in vitro*. *J. Biol. Chem.* **270**:30755-30759.

20. Evans, R. M. 1988. The steroid and thyroid hormone receptor superfamily. *Science* **240**:889–895.
21. Folkers, G. E., E. C. van Heerde, and P. T. van der Saag. 1995. Activation function 1 of retinoic acid receptor beta 2 is an acidic activator resembling VP16. *J. Biol. Chem.* **270**:23552–23559.
22. Fondell, J. D., A. L. Roy, and R. G. Roeder. 1993. Unliganded thyroid hormone receptor inhibits formation of a functional preinitiation complex: implications for active repression. *Genes Dev.* **7**:1400–1410.
23. Freedman, L. P., S. K. Yoshinaga, J. N. Vanderbilt, and K. R. Yamamoto. 1989. *In vitro* transcription enhancement by purified derivatives of the glucocorticoid receptor. *Science* **245**:298–301.
24. Gietz, R. D., and R. H. Schiestl. 1991. Applications of high efficiency lithium acetate transformation of intact yeast cells using single stranded nucleic acids as carrier. *Yeast* **7**:253–263.
25. Giguere, V., S. M. Hollenberg, M. G. Rosenfeld, and R. M. Evans. 1986. Functional domains of the human glucocorticoid receptor. *Cell* **46**:645–652.
26. Gill, G., E. Pascal, Z. H. Tseng, and R. Tjian. 1994. A glutamine rich hydrophobic patch in transcription factor Sp1 contacts the dTAFII110 component of the Drosophila TFIID complex and mediates transcriptional activation. *Proc. Natl. Acad. Sci. USA* **91**:192–196.
27. Goodrich, J. A., and R. Tjian. 1994. TBP TAF complexes: selectivity factors for eukaryotic transcription. *Curr. Opin. Cell Biol.* **6**:403–409.
28. Guarente, L. 1995. Transcriptional coactivators in yeast and beyond. *Trends Biochem. Sci.* **20**:517–521.
29. Halachmi, S., E. Marden, G. Martin, H. MacKay, C. Abbondanza, and M. Brown. 1994. Estrogen receptor associated proteins: possible mediators of hormone induced transcription. *Science* **264**:1455–1458.
30. Ham, J., and M. G. Parker. 1989. Regulation of gene expression by nuclear hormone receptors. *Curr. Opin. Cell Biol.* **1**:503–511.
31. Hollenberg, S. M., and R. M. Evans. 1988. Multiple and cooperative transactivation domains of the human glucocorticoid receptor. *Cell* **55**:899–906.
32. Hong, H., K. Kohli, A. Trivedi, D. L. Johnson, and M. R. Stallcup. 1996. Grip1, a novel mouse protein that serves as a transcriptional coactivator in yeast for the hormone binding domains of steroid receptors. *Proc. Natl. Acad. Sci. USA* **93**:4948–4952.
33. Horvath, A., and H. Riezman. 1994. Rapid protein extraction from *Saccharomyces cerevisiae*. *Yeast* **10**:1305–1310.
34. Ing, N. H., J. M. Beekman, S. Y. Tsai, M. J. Tsai, and B. W. O'Malley. 1992. Members of the steroid hormone receptor superfamily interact with TFIIB (S300 II). *J. Biol. Chem.* **267**:17617–17623.
35. Jacq, X., C. Brou, Y. Lutz, I. Davidson, P. Chambon, and L. Tora. 1994. Human TAFII30 is present in a distinct TFIID complex and is required for transcriptional activation by the estrogen receptor. *Cell* **79**:107–117.
36. Jackson, B. M., C. M. Drysdale, K. Natarajang, and A. G. Hinnebusch. 1996. Identification of seven hydrophobic clusters in Gen4 making redundant contributions to transcriptional activation. *Mol. Cell. Biol.* **16**:5557–5571.
37. Joliot, V., M. Demma, and R. Prywes. 1995. Interaction with RAP74 subunit of TFIIF is required for transcriptional activation by serum response factor. *Nature (London)* **373**:632–635.
38. Kamei, Y., L. Xu, T. Heinzel, J. Torchia, R. Kurokawa, B. Gloss, S. C. Lin, R. A. Heyman, D. W. Rose, C. K. Glass, and M. G. Rosenfeld. 1996. A Cbp integrator complex mediates transcriptional activation and AP 1 inhibition by nuclear receptors. *Cell* **85**:403–414.
39. Kunkel, T. A., J. D. Roberts, and R. A. Zakour. 1987. Rapid and efficient site specific mutagenesis without phenotypic selection. *Methods Enzymol.* **154**:367–382.
40. Lee, W. S., C. C. Kao, G. O. Bryant, X. Liu, and A. J. Berk. 1991. Adenovirus E1A activation domain binds the basic repeat in the TATA box transcription factor. *Cell* **67**:365–376.
41. Lieberman, P. M., and A. J. Berk. 1991. The Zta trans activator protein stabilizes TFIID association with promoter DNA by direct protein-protein interaction. *Genes Dev.* **5**:2441–2454.
42. Lin, J., J. Chen, B. Elenbaas, and A. J. Levine. 1994. Several hydrophobic amino acids in the p53 amino terminal domain are required for transcriptional activation, binding to mdm 2 and the adenovirus 5 E1B 55 kD protein. *Genes Dev.* **8**:1235–1246.
43. Lin, Y. S., I. Ha, E. Maldonado, D. Reinberg, and M. R. Green. 1991. Binding of general transcription factor TFIIB to an acidic activating region. *Nature (London)* **353**:569–571.
44. Lind, U., J. Carlstedt-Duke, J.-Å. Gustafsson, and A. P. Wright. 1996. Identification of single amino acid substitutions of Cys-736 that affect the steroid-binding affinity and specificity of the glucocorticoid receptor using phenotypic screening in yeast. *Mol. Endocrinol.* **10**:1358–1370.
45. Lindebro, M. C., L. Poellinger, and M. L. Whitelaw. 1995. Protein protein interaction via PAS domains: role of the PAS domain in positive and negative regulation of the bHLH/PAS dioxin receptor Arnt transcription factor complex. *EMBO J.* **14**:3528–3539.
46. MacDonald, P. N., D. R. Sherman, D. R. Dowd, S. C. Jefcoat, Jr., and R. K. DeLisle. 1995. The vitamin D receptor interacts with general transcription factor IIB. *J. Biol. Chem.* **270**:4748–4752.
47. Mason, S. A., and P. R. Housley. 1993. Site directed mutagenesis of the phosphorylation sites in the mouse glucocorticoid receptor. *J. Biol. Chem.* **268**:21501–21504.
48. McClary, J. A., F. Witney, and J. Geisselsoder. 1989. Efficient site directed *in vitro* mutagenesis using phagemid vectors. *BioTechniques* **7**:282–289.
49. McEwan, I. J., T. Almlöf, A. C. Wikström, K. Dahlman-Wright, A. P. Wright, and J.-Å. Gustafsson. 1994. The glucocorticoid receptor functions at multiple steps during transcription initiation by RNA polymerase II. *J. Biol. Chem.* **269**:25629–25636.
50. McEwan, I. J., K. Dahlman-Wright, J. Ford, and A. P. H. Wright. 1996. Functional interaction of the c-Myc transactivation domain with the TATA binding protein: evidence for an induced fit model of transactivation domain. *Biochemistry* **35**:9584–9593.
51. McEwan, I. J., A. P. Wright, K. Dahlman-Wright, J. Carlstedt-Duke, and J.-Å. Gustafsson. 1993. Direct interaction of the tau 1 transactivation domain of the human glucocorticoid receptor with the basal transcriptional machinery. *Mol. Cell. Biol.* **13**:399–407.
52. Onate, S. A., S. Y. Tsai, M. J. Tsai, and B. W. O'Malley. 1995. Sequence and characterization of a coactivator for the steroid hormone receptor superfamily. *Science* **270**:1354–1357.
53. O'Neil, K. T., and W. F. DeGrado. 1990. A thermodynamic scale for the helix forming tendencies of the commonly occurring amino acids. *Science* **250**:646–651.
54. Legier, J. L., F. Shen, and S. J. Triezenberg. 1993. Pattern of aromatic and hydrophobic amino acids critical for one of two subdomains of the VP16 transcriptional activator. *Proc. Natl. Acad. Sci. USA* **90**:883–887.
55. Roeder, R. G. 1991. The complexities of eukaryotic transcription initiation: regulation of preinitiation complex assembly. *Trends Biochem. Sci.* **16**:402–408.
56. Roseman, M. A. 1988. Hydrophilicity of polar amino acid side chains is markedly reduced by flanking peptide bonds. *J. Mol. Biol.* **200**:513–522.
57. Rowlands, R. C., I. J. McEwan, and J.-Å. Gustafsson. 1996. Transactivation by the human aryl hydrocarbon receptor and ARNT proteins: direct interactions with basal transcription factors. *Mol. Pharmacol.* **50**:965–968.
58. Sauer, F., S. K. Hansen, and R. Tjian. 1995. Multiple TAFIIIs directing synergistic activation of transcription. *Science* **270**:1783–1788.
59. Schiestl, R. H., and R. D. Gietz. 1989. High efficiency transformation of intact yeast cells using single stranded nucleic acids as a carrier. *Curr. Genet.* **16**:339–346.
60. Schmitz, M. L., M. A. dos Santos Silva, H. Altmann, M. Czisch, T. A. Holak, and P. A. Baeuerle. 1994. Structural and functional analysis of the NF kappa B p65 C terminus. An acidic and modular transactivation domain with the potential to adopt an alpha helical conformation. *J. Biol. Chem.* **269**:25613–25620.
61. Schmitz, M. L., G. Stelzer, H. Altmann, M. Meisterernst, and P. A. Baeuerle. 1995. Interaction of the COOH terminal transactivation domain of p65 NF kappa B with TATA binding protein, transcription factor IIB, and coactivators. *J. Biol. Chem.* **270**:7219–7226.
62. Schüle, R., M. Muller, C. Kaltschmidt, and R. Renkawitz. 1988. Many transcription factors interact synergistically with steroid receptors. *Science* **242**:1418–1420.
63. Schwerk, C., M. Klotzbucher, M. Sachs, V. Ulber, and L. Klein-Hitpass. 1995. Identification of a transactivation function in the progesterone receptor that interacts with the TAFII110 subunit of the TFIID complex. *J. Biol. Chem.* **270**:21331–21338.
64. Shen, F., S. J. Triezenberg, P. Hensley, D. Porter, and J. R. Knutson. 1996. Transcriptional activation domain of the herpesvirus protein VP16 becomes conformationally constrained upon interaction with basal transcription factors. *J. Biol. Chem.* **271**:4827–4837.
65. Sigler, P. B. 1988. Transcriptional activation. Acid blobs and negative noodles. *Nature (London)* **333**:210–212.
66. Sikorski, R. S., and P. Hieter. 1989. A system of shuttle vectors and yeast host strains designed for efficient manipulation of DNA in *Saccharomyces cerevisiae*. *Genetics* **122**:19–27.
67. Strähle, U., G. Klock, and G. Schutz. 1988. A DNA sequence of 15 base pairs is sufficient to mediate both glucocorticoid and progesterone induction of gene expression. *Cell* **55**:899–906.
68. Stringer, K. F., C. J. Ingles, and J. Greenblatt. 1990. Direct and selective binding of an acidic transcriptional activation domain to the TATA box factor TFIID. *Nature (London)* **345**:783–786.
69. Truant, R., H. Xiao, C. J. Ingles, and J. Greenblatt. 1993. Direct interaction between the transcriptional activation domain of human p53 and the TATA box binding protein. *J. Biol. Chem.* **268**:2284–2287.
70. Tsai, S. Y., G. Srinivasan, G. F. Allan, E. B. Thompson, B. W. O'Malley, and M. J. Tsai. 1990. Recombinant human glucocorticoid receptor induces transcription of hormone response genes *in vitro*. *J. Biol. Chem.* **265**:17055–17061.
71. Van Hoy, M., A. Hansen, and T. Kodadek. 1992. Spectroscopic studies of a transcriptional activation peptide. *J. Am. Chem. Soc.* **114**:362–363.
72. Van Hoy, M., K. K. Leuther, T. Kodadek, and S. A. Johnston. 1993. The acidic activation domains of the GCN4 and GAL4 proteins are not alpha helical but form beta sheets. *Cell* **72**:587–594.
73. vom Baur, E., C. Zechel, D. Heery, M. J. Heine, J. M. Garnier, V. Vivat, B.

- Le Douarin, H. Gronemeyer, P. Chambon, and R. Losson.** 1996. Differential ligand dependent interactions between the AF 2 activating domain of nuclear receptors and the putative transcriptional intermediary factors mSUG1 and TIF1. *EMBO J.* **15**:110-124.
74. **Ward, A. C.** 1990. Single step purification of shuttle vectors from yeast for high frequency back transformation into *E. coli*. *Nucleic Acids Res.* **18**:5319.
75. **Whitelaw, M. L., M. Göttlicher, J.-Å. Gustafsson, and L. Poellinger.** 1993. Definition of a novel ligand binding domain of a nuclear bHLH receptor: colocalization of ligand and hsp90 binding activities within the regulable inactivation domain of the dioxin receptor. *EMBO J.* **12**:4169-4179.
76. **Wright, A. P., J. Carlstedt-Duke, and J.-Å. Gustafsson.** 1990. Ligand specific transactivation of gene expression by a derivative of the human glucocorticoid receptor expressed in yeast. *J. Biol. Chem.* **265**:14763-14769.
77. **Wright, A. P., I. J. McEwan, K. Dahlman-Wright, and J.-Å. Gustafsson.** 1991. High level expression of the major transactivation domain of the human glucocorticoid receptor in yeast cells inhibits endogenous gene expression and cell growth. *Mol. Endocrinol.* **5**:1366-1372.
78. **Xiao, H., A. Pearson, B. Coulombe, R. Truant, S. Zhang, J. L. Regier, S. J. Triezenberg, D. Reinberg, O. Flores, C. J. Ingles, and J. Greenblatt.** 1994. Binding of basal transcription factor TFIID to the acidic activation domains of VP16 and p53. *Mol. Cell. Biol.* **14**:7013-7024.
79. **Zawel, L., and D. Reinberg.** 1995. Common themes in assembly and function of eukaryotic transcription complexes. *Annu. Rev. Biochem.* **64**:533-561.
80. **Zeiner, M., and U. Gehring.** 1995. A protein that interacts with members of the nuclear hormone receptor family: identification and cDNA cloning. *Proc. Natl. Acad. Sci. USA* **92**:11465-11469.