

# Effects of Aldicarb on the Behavior of *Heterodera schachtii* and *Meloidogyne javanica*<sup>1</sup>

A. HOUGH and I. J. THOMASON<sup>2</sup>

**Abstract:** The toxic effects of sublethal concentrations of aldicarb were studied on eggs and second-stage larvae and males of *Heterodera schachtii* and second-stage larvae only of *Meloidogyne javanica* in a quartz sand substrate. Aldicarb was more toxic to eggs of *H. schachtii* than to those of *M. javanica*. Complete suppression of hatching occurred between 0.48 and 4.8  $\mu\text{g/ml}$  aldicarb for *H. schachtii* whereas 100% inhibition of hatch of *M. javanica* occurred between 4.8 and 48.0  $\mu\text{g/ml}$ . *M. javanica* hatch was stimulated at 0.48  $\mu\text{g/ml}$  aldicarb. Migration of second-stage larvae of *H. schachtii* and *M. javanica* in sand columns was inhibited under continuous exposure to 1  $\mu\text{g/ml}$  aldicarb. Infection of sugarbeet and tomato seedlings by larvae was inhibited at 1  $\mu\text{g/ml}$ . *H. schachtii* males failed to migrate toward nubile females at 0.01  $\mu\text{g/ml}$  aldicarb. This was partially confirmed in a field study in which adding aldicarb to soil resulted in fewer females being fertilized. **Key Words:** cyst nematode, root-knot nematode, nematicide, hatching, movement, sex attractant, infectivity, systemic action, mode of action.

---

A new class of carbamate insecticides-nematicides, the *o*-(methyl-

Received for publication 29 October 1974.

<sup>1</sup>Portion of a Ph.D. dissertation submitted by the senior author to the University of California, Riverside. The authors acknowledge the donation of the experimental compounds by Union Carbide Corporation, New York, N.Y. USA.

<sup>2</sup>Department of Nematology, University of California, Riverside, 92502. Present address of senior author: Outspan Citrus Centre, P. O. Box 28, Nelspruit, South Africa.

carbamoyl)oximes, was introduced by Union Carbide Corporation (26). One of these compounds, aldicarb (Temik<sup>®</sup> 10G) is registered for use on several crops for the control of insect and nematode pests. The nematicidal properties of aldicarb against the root-knot nematode *Meloidogyne incognita* (Kofoid & White) Chitwood, were first

reported by Spurr and Sousa (23). Numerous reports have appeared since, confirming the efficacy of aldicarb against a wide range of nematode pests.

It has been suggested that nematicidal activity of certain carbamoyloximes like aldicarb may be due to the inhibition of acetylcholinesterases and cholinesterases (22). Impairment of the nervous system can interfere with many vital processes in the life cycle of nematodes.

Aldicarb, like many carbamate and organophosphate nematicides, may not control nematodes by killing at recommended rates of application, but rather by indirect effects (3, 13). The effects of these nematicides are usually subtle and involve inhibition of various functions in nematodes over a wide range of concentrations. It is known that hatching, movement, feeding behavior, orientation or development of larvae can be impaired at low concentrations of these compounds.

The initiation of hatching processes of *Heterodera* spp. is influenced by a number of pesticides and soil sterilants (2). Inhibition of hatching was recorded by Osborne (20) and by Steudel (24) when cysts of *Heterodera rostochiensis* Woll. and *Heterodera schachtii* Schm., respectively, were exposed to aldicarb at 1.0 to 10.0  $\mu\text{g}/\text{ml}$ . Hatching of *M. incognita* was also suppressed by aldicarb (19). Aldicarb apparently did not affect embryos contained in the eggs of *Meloidogyne arenaria* (Neal) Chitwood since the development of the embryos appeared to be normal even when exposed to concentrations as high as 50  $\mu\text{g}/\text{ml}$  aldicarb (1). The larvae failed to hatch at this concentration, but larvae that hatched in aldicarb concentrations of 10.0 and 20.0  $\mu\text{g}/\text{ml}$  were infective and more larvae hatched at 10.0  $\mu\text{g}/\text{ml}$  aldicarb than in the check treatment.

Many researchers have utilized nematode movement as a criterion for in vitro screening of nematicidal compounds. Nematodes exposed to a toxicant are either classified as motile or nonmotile. Lack of motility often is equated with lack of infectivity or death, and the potency of a candidate compound is thereupon evaluated (16). Nelmes (18) has shown that aldicarb interferes with the movement of nematodes at low concentrations.

Under laboratory conditions nematodes exposed to low concentrations of a toxicant,

may recover and become active when the toxicant is removed (6). The in vitro evaluation of various nonfumigant nematicides with cholinesterase-inhibiting properties can be misleading when their action is assessed by nematode motility tests which involve removal of the toxicant prior to the assay. Many of the cholinesterase-inhibiting toxicants exhibit reversible reaction with the substrate (27). Treated nematodes often recover fully after the toxicant is removed. Nematicidal activity should therefore be assessed while the nematodes are in contact with the toxicant.

Measurement of toxicity is complex in the case of nonfumigant-type nematicides. Many organophosphates and carbamates will kill nematodes only at very high dosages. It is believed that the mode of action of these compounds is nematostatic (14). The situation is further complicated by the reversibility of intoxication with carbamate nematicides at sublethal dosages. Nematostasis occurs during the period that nematodes are continuously exposed to fluctuating concentrations of the nematicide in the soil water. There is, therefore, a need to determine effects of these compounds on infectivity of nematodes in the presence of toxicants. Concentrations of toxicant in water films with which nematodes are in contact should bear a reasonable relationship to what might be expected under field conditions.

Nematodes respond to various chemical stimuli in their environment. Attraction of larvae to certain areas of roots of host plants (21, 25), indicate mechanisms of orientation are necessary for survival of plant parasitic nematodes. The nematicides carbofuran (4) and carbaryl (8) appear to interfere with nematode orientation.

Males of *Heterodera* spp. are attracted to their females (9) and can migrate considerable distances towards females in sand columns (7). *H. schachtii* is an amphimictic species, and interferences with fertilization of females through disorientation of males should result in sterility and lower rates of population increase.

Tests were conducted to determine effects of aldicarb on (i) hatching of *M. javanica* eggs and eggs in cysts of *H. schachtii*, (ii) movement and penetration of host roots by second-stage larvae of the above nematodes, and (iii) movement of males of *H. schachtii* to nubile females. A field trial tested the effect of

aldicarb on the fertilization of females by males of *H. schachtii*.

## MATERIALS AND METHODS

Aldicarb used in laboratory tests was obtained from the Union Carbide Corporation and was technical grade (99.9 percent pure). All data presented on aldicarb solutions are in concentrations of technical material.

All cysts of *H. schachtii* used directly or as a source of larvae were obtained from sugarbeets, *Beta vulgaris* L. 'HH9' grown in quartz sand in the greenhouse. Plants were fertilized weekly with Hoagland's nutrient solution. Males were obtained from roots of beets grown at a soil temperature of 27 C. Twelve days after inoculation, roots were placed on funnels in a mist chamber at 27 C. Males emerging from roots were collected daily. Young, nubile females were hand picked from similar roots 18-20 days after inoculation.

*M. javanica* was maintained on tomato, *Lycopersicon esculentum* L. 'Pearson', in the greenhouse and larvae obtained from roots incubated in a mist chamber. Egg masses were hand picked from the surface of tomato roots with forceps when needed.

All treatments were replicated at least four times, and all tests repeated for confirmation except for the field trial. Data were subjected to analysis of variance and other statistical treatment when appropriate.

**Laboratory experiments:** A hatching apparatus was made from plexiglass (Fig. 1). Four 1.5-cm diam holes were drilled in a 2.4 × 10 × 10 cm block of plexiglass and another 1.2 cm thick. In a third block 2.4 cm thick the holes were only drilled to a depth of 2.0 cm. A 4-mm hole was then drilled in the bottom of each of these holes and drainage tube cemented in place. On top of each hole in the 2.4-cm thick blocks a depression 1 mm deep and 2.5 cm in diam was formed to receive plastic screens (Fig. 1b). Screens held 150- to 250- $\mu$ m quartz sand in place, but allowed liquids to drain and larvae to be removed. The three sections of the chamber were held together with bolts.

Cysts of *H. schachtii* and egg masses of *M. javanica* were placed on top of sand in the hatching chamber. Hatching solutions containing aldicarb at 0.0, 0.48, 4.8 and 48  $\mu$ g/ml (0.0,  $2.5 \times 10^{-3}$ ,  $2.5 \times 10^{-2}$ , and  $2.5 \times$

$10^{-1}$  mmole aldicarb per liter) were added to each hatching chamber and allowed to percolate through the sand. Both ends of each chamber were closed after hatching solution had stopped draining from the sand. Hatched larvae were washed from each hatching chamber after incubation for 5 days. Hatching solution containing aldicarb was replaced, and incubation was continued for 5 more days; the same procedure was repeated. Infectivity of hatched larvae was determined by inoculating HH9 sugarbeet seedlings with *H. schachtii* larvae or Pearson tomato seedlings with *M. javanica* larvae. Roots of seedlings were fixed and stained 5 days after inoculation, and percentage of total hatched larvae capable of penetrating the roots was determined.

*H. schachtii* cysts recovered from beet

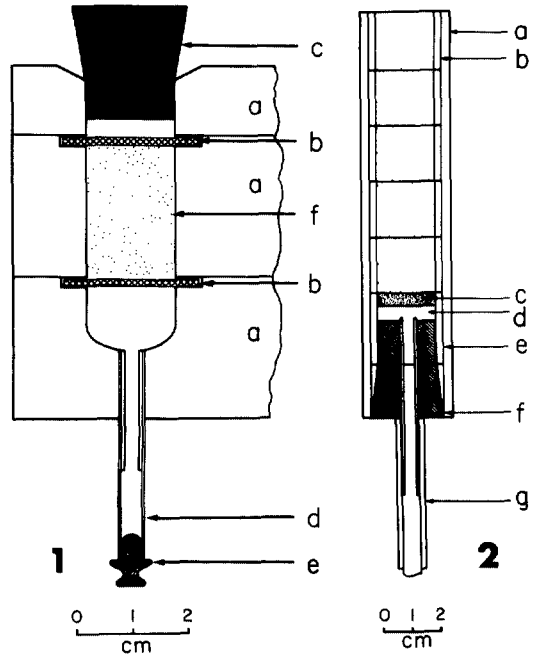

FIG. 1-2. 1) Hatching chamber made of (a) plexiglass plates (b) nylon screens (c) rubber stopper (d) vinyl tubing, and (e) metal stopper. Cysts or egg masses placed in top part of quartz sand (f). Stoppers (c) and (e) removed, aldicarb-solutions added to top of sand and allowed to drain out. Larvae flushed out and were collected and counted. 2) Column for studying migration of second-stage larvae in quartz sand. Column was made of (a) plexiglass tubing (b) polyethylene rings (c) ceramic disk (d) solution chamber (e) polyethylene ring attached to ceramic disk, and (f) rubber stopper. Sand column placed under 22 mbar tension by connecting vinyl tubing (g) to reservoir of either water or aldicarb solution. Larvae placed on sand at top of column.

roots, with 97% of the eggs fully embryonated, were used in hatching studies. Forty cysts with an average of 153 eggs/cyst were used in each hatching chamber. Each hatching chamber was considered as one replicate with four/treatment. Hatching solutions used for *H. schachtii* contained 3 mM ZnCl<sub>2</sub>. The pH of hatching solutions was 6.1. Cysts were incubated in cycles; 2 days at 15 C and 3 days at 24 C. The experiment was continued for 50 days.

Egg masses of *M. javanica* contained an average of 398 eggs, 51% of which were fully developed. Ten egg masses were used in each hatching chamber. The hatching solution used for *M. javanica* was 0.02 M phosphate buffer at pH 7.0. Eggs were incubated continuously at 27 C for 5 days. The experiment was continued for 35 days.

Movement of nematodes was studied in quartz sand columns which were a modification of systems used by Evans (7). The columns (Fig. 2) consisted of an outer plexiglass tube which supported an inner column of polyethylene tubing. The polyethylene tubing in each column was precut into five 2-cm sections. Columns were filled with 150- to 250- $\mu$ m quartz sand. A porous ceramic disk with an air entry value (bubbling pressure) of 1/4 bar was fixed to the base of each column. Sand in the columns was prewetted with an aldicarb solution, and a tension of approximately 22 mbar was maintained on each column by adjustment of a vinyl tube which connected the sand columns with a reservoir of aldicarb solution. There were five treatments; 0.0, 0.1, 0.5, 1.0 and 5.0  $\mu$ g/ml aldicarb (1.0  $\mu$ g/ml =  $5.25 \times 10^{-3}$  mmole/l).

Active, second-stage larvae of *H. schachtii* and *M. javanica* were pre-exposed to aldicarb solutions for 12 h at 15 C. Treated larvae (2,000 per column) were then transferred in a small volume of aldicarb solution to the top of sand columns containing corresponding aldicarb concentrations. Tops of columns were sealed with Parafilm to prevent evaporation. Larvae were allowed to move through the sand for 48 h at 26 C before the columns were disassembled. The sand from individual sections was suspended in water. The water was decanted before the nematodes settled and brought up to a specific volume. Nematodes in 5 ml of suspension from each section were counted to determine the distribution of the larvae in the columns.

Infectivity of second-stage larvae of *H. schachtii* and *M. javanica* was measured at constant exposure to aldicarb in the presence of a host plant. Two-week-old sugarbeet or tomato seedlings were transplanted to the sand columns previously described. The columns were filled with Hoagland's nutrient solution and kept at a tension of 22 mbar. Larvae were pre-exposed to several concentrations of aldicarb, 0.0, 0.01, 0.1, and 1.0  $\mu$ g/ml aldicarb for 8 h prior to inoculation. The nutrient solution was flushed out of the columns and replaced with aldicarb solutions similar in concentration to those used in pre-exposure. Tension was again adjusted to 22 mbar. Each column containing a sugarbeet seedling was infested 3 days after transplant by pipetting 3,000 larvae of *H. schachtii* onto the top of the sand. The same procedure was used in columns planted with tomato seedlings except that 4,000 larvae of *M. javanica* per plant were added. Plants were kept at approximately 27 C for 3 days, when the columns were disassembled. Roots of seedlings were fixed, stained, and macerated to permit estimation of the number of larvae in the roots.

Effects of aldicarb on the orientation of males towards the females of *H. schachtii* was studied in sand columns similar to those used in the larval movement studies. The moisture tension in the 250- to 500- $\mu$ m sand in this experiment was maintained at 15 mbar. There were six treatments; 0.0, 0.001, 0.01, 0.1, 1.0, and 10.0  $\mu$ g/ml aldicarb.

Three-hundred males of *H. schachtii* were introduced midway between the top and bottom of each column. Columns were kept at 27 C for 72 h in order to allow the males to migrate upwards to the females which had been placed at the top of the columns. After disassembling columns, distribution of males in various sections was determined.

*Field experiment:* Double-row sugarbeet beds in noninfested loam soil were side dressed with Temik® 10 G (10% granular formulation). The nematicide was placed 7.5 cm deep and 2.5 cm inside the shoulder of the beds. There were two application rates, 2.5 kg a.i./ha and 5.0 kg a.i./ha and a control. Sugarbeet seedlings with well-developed tap roots were transplanted in the seedrow. The soil around the plants was infested with 500 second-stage larvae of *H. schachtii*, 1 week after transplanting. The field was irrigated three times during the experiment with a total

of 600 mm of water. The mean maximum and minimum temperatures at 30 cm depth were 29.9 C and 22.4 C, respectively. The sugarbeets were allowed to grow for 36 days after inoculation before they were removed and the white females (mature and immature 5th-stage females) were collected from the soil and the roots. Total numbers of females recovered were counted, and the percentage of females with eggs was determined. The experimental design was a randomized complete block with three treatments and four replicates.

## RESULTS

### Laboratory experiments: Hatching of *H.*

*schachtii* eggs was inhibited ( $P = 0.01$ ) at 4.8  $\mu\text{g}/\text{ml}$  aldicarb (Fig. 3). The 0.48  $\mu\text{g}/\text{ml}$  aldicarb treatment had no effect on hatch. Hatching of *M. javanica* appeared to be less affected by aldicarb than *H. schachtii* (Fig. 4). About 10 percent of the eggs of *M. javanica* hatched in an aldicarb solution of 4.8  $\mu\text{g}/\text{ml}$ , compared to complete suppression of hatch of *H. schachtii* at this concentration. An increase in the total hatch of *M. javanica* eggs was recorded at 0.48  $\mu\text{g}/\text{ml}$  ( $P = 0.01$ ) (Fig. 4). Larvae of *H. schachtii* and *M. javanica* which hatched under these experimental conditions were infective after removal from the aldicarb solutions.

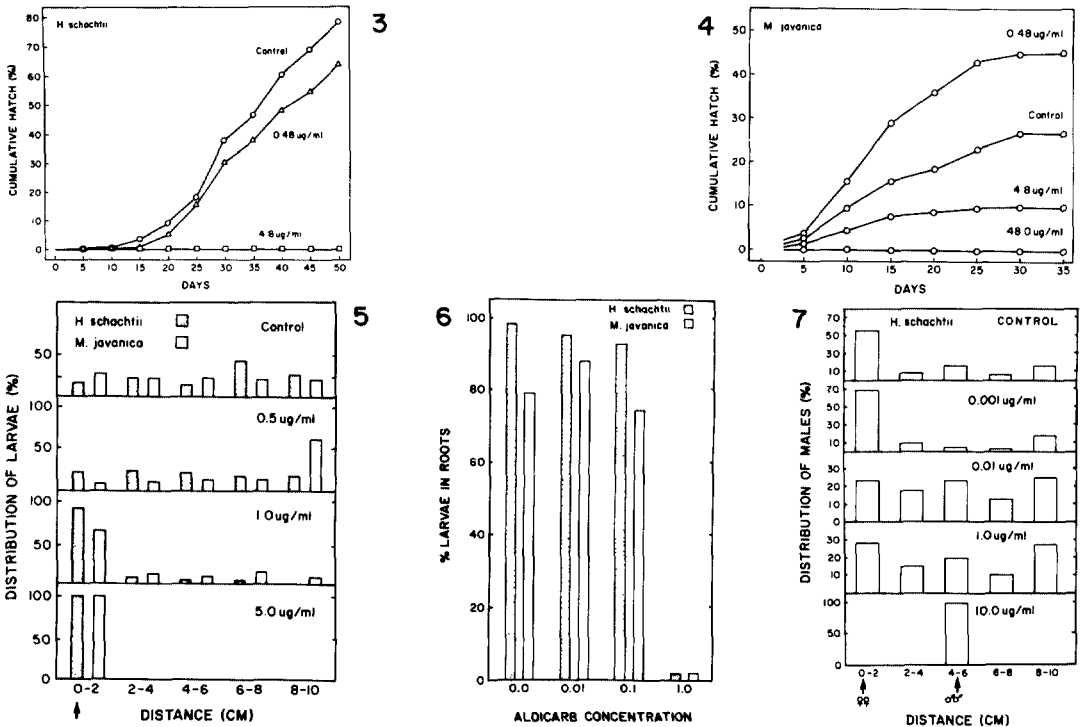

FIG. 3-7. 3-4) Percent cumulative hatch of *Heterodera schachtii* (3) or *Meloidogyne javanica* (4) over periods of 50 and 35 days, respectively. Incubation cycle was 2 days at 15 C and 3 days at 24 C after which larvae were removed. Aldicarb in 3mM  $\text{ZnCl}_2$  solutions were replaced and incubation continued. Hatch of *H. schachtii* eggs was inhibited ( $P = 0.01$ ) at 4.8  $\mu\text{g}/\text{ml}$  aldicarb. The 0.48  $\mu\text{g}/\text{ml}$  had no effect. Hatch of *M. javanica* eggs was inhibited ( $P = 0.01$ ) at 4.8 and 48.0  $\mu\text{g}/\text{ml}$ . An increase ( $P = 0.01$ ) in total hatch occurred at 0.48  $\mu\text{g}/\text{ml}$ . 5) Movement of larvae of *H. schachtii* and *M. javanica* as affected by aldicarb. Larvae introduced at top of column (black arrow). Larvae from water controls were distributed uniformly in the sand after 48 h ( $P = 0.01$ ). Distribution of *H. schachtii* uniform at 0.5  $\mu\text{g}/\text{ml}$  ( $P = 0.01$ ) but distribution of *M. javanica* at this concentration nonuniform ( $P = 0.01$ ). Distribution of larvae of both species nonuniform ( $P = 0.01$ ) at 1.0 and 5.0  $\mu\text{g}/\text{ml}$ . Distribution of larvae at 1.0 and 5.0  $\mu\text{g}/\text{ml}$  differed ( $P = 0.01$ ) from the control. 6) Percent of inoculated larvae of *H. schachtii* and *M. javanica* recovered from roots of sugarbeet and tomato seedlings, respectively, as influenced by aldicarb. Larvae introduced in top of quartz sand column (Fig. 2) in which seedlings had been growing 3 days. Invasion of both species did not differ ( $P = 0.01$ ) from control at 0.01 and 0.1  $\mu\text{g}/\text{ml}$  aldicarb. Larvae invading roots at 1.0  $\mu\text{g}/\text{ml}$  aldicarb markedly different ( $P = 0.01$ ) from control. 7) Distribution of *H. schachtii* males in sand columns (Fig. 2) under exposure to aldicarb with relation to the position of females in the columns. Arrows indicate position of males and females at start of the test. Distribution patterns of males in the water control and 0.001  $\mu\text{g}/\text{ml}$  aldicarb were nonuniform ( $P = 0.05$ ). Distribution at 0.01 and 1.0  $\mu\text{g}/\text{ml}$  were uniform ( $P = 0.05$ ). Males did not migrate at 10.0  $\mu\text{g}/\text{ml}$  and distribution was nonuniform ( $P = 0.01$ ).

Larvae of *H. schachtii* and *M. javanica* from controls were distributed uniformly in sand after 48 h ( $P=0.01$ ) (Fig. 5), whereas the distribution of larvae in the columns was restricted by aldicarb and varied with concentration (Fig. 5). The distribution of *H. schachtii* was uniform at 0.5  $\mu\text{g/ml}$ , but the distribution of *M. javanica* was nonuniform ( $P=0.01$ ). Larval movement at 1.0  $\mu\text{g/ml}$  aldicarb was greatly inhibited. Relatively few of either species migrated downwards, but a small percentage of *M. javanica* migrated to the bottom of the columns. *H. schachtii* appeared to be more sensitive to aldicarb, and no larvae were detected at a distance of 8-10 cm from the top of the columns. No migration of larvae occurred at 5.0  $\mu\text{g/ml}$  aldicarb, and the distribution of both species was different ( $P=0.01$ ) from that of the control. Concentrations of 1.0 and 5.0  $\mu\text{g/ml}$  aldicarb completely inhibited the movement of larvae in this quartz sand-aldicarb system.

Infection of seedlings in controls in the quartz sand columns was heavy, even though the roots were very small. Numbers of larvae in the roots were expressed as percentages of total numbers of larvae applied (Fig. 6). Dosages of aldicarb at 0.0, 0.01, and 0.1  $\mu\text{g/ml}$  did not affect the invasive capacity of larvae. However, a marked inhibition of invasion of roots was encountered when larvae were exposed to 1.0  $\mu\text{g/ml}$  aldicarb in the sand columns ( $P=0.01$ ). This was the concentration that depressed larval movement.

Orientation studies with *H. schachtii* males indicated that aldicarb affected the migration of males toward the females (Fig. 7). In columns without aldicarb the majority of males migrated from the middle of the columns to the females at the top of the columns. At very low concentrations a stimulatory effect was observed as more males migrated towards the females when exposed to 0.001  $\mu\text{g/ml}$  aldicarb than in the control ( $P=0.05$ ). At 0.01  $\mu\text{g/ml}$  males were uniformly distributed in the sand, indicating that they had lost their ability to orient to females when the dosage was increased. The distribution patterns of males in controls and 0.001  $\mu\text{g/ml}$  treatments were nonuniform ( $P=0.05$ ), whereas the distribution patterns at 0.01 and 1.0  $\mu\text{g/ml}$  aldicarb were uniform ( $P=0.05$ ). At the dosage of 10.0  $\mu\text{g/ml}$  there was no migration. The ability of males to migrate was not affected by any dosage except 10.0  $\mu\text{g/ml}$ .

*Field experiment:* Results from this trial indicated that fewer females were fertilized in the 2.5 and 5.0 kg/ha aldicarb treatments than in the controls ( $P=0.05$ ). The percentage females fertilized in the control was 69% as compared with 49% and 45% for the low and high rates of aldicarb. Numbers of females recovered from all the treatments were similar ( $P=0.01$ ), and the data obtained cannot therefore be attributed to underpopulations of females in only the aldicarb treatments.

## DISCUSSION

Our understanding of the mode of action of carbamoyloxime, carbamate, and organophosphate nematocides in terms of their effects on behavioral aspects of nematodes is in its infancy. In addition, only circumstantial evidence of the mode of action of these nematocides on a molecular level has been obtained. Many of the in situ effects reported not only are obscure, but are difficult to measure because nematodes are natural inhabitants of soil. It follows that the mode of action and interactions of organophosphates and carbamate nematocides with nematodes, are not fully understood or considered when nematocide screening tests are conducted. Nematocide concentrations in in vitro studies are often too narrow, and are usually too high to determine the more subtle behavioral effects induced by these toxicants.

The results obtained in these hatching studies indicate that aldicarb exhibits similar effects on hatching of nematodes as that recorded for other carbamate nematocides and fungicides. Eggs that were exposed for long periods to high concentration of aldicarb in combination with the hatching stimulant  $\text{ZnCl}_2$  were irreversibly injured and failed to hatch when the aldicarb was replaced with another hatching stimulant such as sugarbeet root diffusate. These data support previous studies on the effects of aldicarb on hatching of eggs of *H. schachtii* (24) and *H. rostochiensis* (20).

Hatching of *H. schachtii* has been shown to be stimulated in 1.0  $\mu\text{g/ml}$  aldicarb, but not when the aldicarb was combined with rye (*Secale cereale* L.) and rape (*Brassica napus* L.) diffusate (24). We used 3 mM  $\text{ZnCl}_2$  as a hatching stimulant for *H. schachtii* in combination with aldicarb, and this may explain why we failed to obtain the observed

stimulatory effect at low concentrations of aldicarb.

Larval emergence of *M. javanica* was completely inhibited at 48.0  $\mu\text{g}/\text{ml}$  ( $2.5 \times 10^{-1}$  mM), which is in the range of concentrations found to completely inhibit the hatch of *M. arenaria* (1) and *M. incognita* (19). Exposure to low concentrations of aldicarb (0.48  $\mu\text{g}/\text{ml}$ ) caused a stimulation in the hatch of *M. javanica*. Stimulation of hatching of *M. incognita* eggs was not observed by Nelmes and Keerweewan (19). However, Berge and Cuany (1) found 75% of the larvae of *M. arenaria* to hatch in 10  $\mu\text{g}/\text{ml}$  aldicarb as compared with 66% in controls.

Interesting implications arise from this and other investigations with aldicarb on hatching of nematodes. Hatching of *H. schachtii* and *M. javanica* in aldicarb solution, took place at dosages which inhibit larval movement. This implies that aldicarb concentrations inside eggs were considerably lower than the concentrations outside. The stimulatory effect of aldicarb on hatching of *H. schachtii* was counteracted in the presence of a hatching stimulant. More larvae of *H. rostochiensis* were killed when cysts were exposed to aldicarb and root diffusate mixtures when compared with aldicarb treatments alone (20). A possible explanation for these phenomena is that the permeability of the egg shell layer is changed by hatching stimulants which in turn permits entry of a lethal or inhibitory concentration of aldicarb inside the egg.

The stimulatory effect of certain dosages of aldicarb on hatching of nematodes could be due to increased activity of larvae induced by exposure to very low concentrations of aldicarb prior to hatching. Increased reproduction of *Aphelenchoides rutgersi* Hooper and Myers was demonstrated by Myers (17) in axenic culture containing 0.1  $\mu\text{g}/\text{ml}$  aldicarb. The increased fecundity is an interesting manifestation of aldicarb intoxication which could be the result of hyperactivity of exposed nematodes.

Low concentrations of aldicarb evoked abnormal stylet thrusting behavior in *H. rostochiensis* larvae (18). If discoordinated stylet thrusting behavior of *Heterodera* larvae occur in the egg, hatching will be affected. The precise orientation necessary to cut a continuous slit in the egg shell (5) may also be disrupted by acetylcholinesterase-inhibiting properties of aldicarb. These phenomena may explain the sensitivity of *Heterodera* spp. as

compared with *Meloidogyne* spp. which do not exhibit such sophisticated behavior prior to hatching.

Aldicarb is reported to interfere with hatching of *H. schachtii* and *H. rostochiensis* under field conditions (20, 24). Our laboratory studies confirmed that hatching of *H. schachtii* and *M. javanica* can be completely inhibited at 4.8  $\mu\text{g}/\text{ml}$  and 48.0  $\mu\text{g}/\text{ml}$ , respectively. However, the studies by Hague and Paine (11) and Zambelli and De Leonardis (28), do not support such a mode of action in the field. They recovered numerous *H. rostochiensis* larvae from soil in the rhizosphere. This suggests that aldicarb concentrations in the soil were not sufficient to prevent hatching but were high enough to prevent infection. In tests conducted under field conditions, Hough et al. (12) found concentrations of aldicarb in the soil water of a Holtville clay were too low, and the areas in the soil profile of the Buren silt loam where more than 4.8  $\mu\text{g}/\text{ml}$  aldicarb occurred were too small, for interference with hatching to be a major factor.

Aldicarb has been reported to inhibit undulatory movement of *H. rostochiensis* larvae at 1.0  $\mu\text{g}/\text{ml}$ , and the toruosity of the tracks of *M. incognita* treated with aldicarb increased (18). Effective migration of both *H. schachtii* and *M. javanica* was impaired at 1.0  $\mu\text{g}/\text{ml}$  in our tests and 5.0  $\mu\text{g}/\text{ml}$  caused complete paralysis. It was concluded from these data that nematode larvae fail to reach host roots if at least 1.0  $\mu\text{g}/\text{ml}$  aldicarb is present in soil water.

Organophosphates and carbamates are thought to affect orientation of nematodes. The nematicide carbofuran was reported by DiSanzo (4) to interfere with orientation of *Tylenchorhynchus claytoni* Steiner to corn roots in sand. He also observed that larvae of *Pratylenchus penetrans* (Cobb), Filip. & Shuur.-Stekh. are not attracted to tomato roots on agar surfaces containing carbofuran. He further observed that larvae did not attempt to feed or penetrate when they reached tomato roots accidentally.

We thought that aldicarb might interfere with the orientation of larvae to roots at lower concentrations than 1.0  $\mu\text{g}/\text{ml}$ . A biological assay indicated that larvae of both species were capable of finding and infecting host roots under continuous exposure to specific dosages of aldicarb less than 1.0  $\mu\text{g}/\text{ml}$ . Infectivity was greatly depressed at 1.0

$\mu\text{g/ml}$ . These findings indicate that interference with infection by larvae is due to impairment of migration of larvae to the host rather than a lack of orientation induced by aldicarb.

Another check on orientation mechanisms was made by utilizing the extraordinary sensitive perception of the female sex attractant by males of *H. schachtii* (9). Extremely low dosages (0.01  $\mu\text{g/ml}$ ) of aldicarb impaired the behavioral activities of the males in our tests, but it took a 1,000-fold increase in concentration of aldicarb to induce paralysis of males, indicating that at least two different functions are involved. It is not clear whether the males failed to perceive the female sex attractant when exposed to 0.01  $\mu\text{g/ml}$  aldicarb or whether they failed to discern concentration gradients. Organophosphates and carbamates may cause marked changes in the release of hormones in insects (15). The possibility that some changes in production and excretion of hormones by females of *H. schachtii* occurred in the presence of aldicarb in these tests and rendered them unattractive to males, cannot be excluded. However, in tests conducted by Greet et al. (10) females treated with ultraviolet light, moderate heat, and subjected to drying were still attractive to males. This suggests that the attractant substance already associated with nubile females would not be inactivated by aldicarb in the 48 h used for the tests.

This information has significant implications with regard to the control of nematode species which require males to fertilize females to enable egg production. Our field test confirmed that disruption of female fertilization can be achieved in the field. The effect was not complete inhibition of reproduction, but it may help explain why Thomason (unpublished data) found fewer eggs at the end of the sugarbeet season in aldicarb-treated field plots.

Aldicarb may interfere with acetylcholinesterase and cholinesterases of nematodes since the  $I_{50}$  of acetylcholinesterase is  $6.5 \times 10^{-6}$  M according to Spurr (22). This is considerably lower than  $ED_{50}$  of  $2.6 \times 10^{-3}$  M for nematode inhibition. However, interference with male orientation occurred at a concentration of  $5.25 \times 10^{-8}$  M which indicates that these receptor sites are highly exposed to the environment or that inhibition of cholinesterase may not be involved in this reaction. Nevertheless, this information may

aid in explaining the great sensitivity of female perception by males as well as the apparent fatigue of sensory receptors of the males when in close proximity to females (9). The ease of disorientation of males as compared with larvae, may be due to the sensory receptors of larvae being less sensitive to aldicarb or the involvement of different sensory mechanisms. It may be that larval orientation to numerous roots ramifying through the soil mass is not as critical to the survival of the nematode species as is the need for male and female to come together especially at low population densities.

The subtleties of intoxication of nematodes by aldicarb is clearly demonstrated by these experiments. This information must be used as it applies to field conditions in order to determine its significance. High levels of many organophosphate and carbamate nematicides may cause paralysis or death, but such high concentrations of the toxicant may not be present in the soil and may play no role in the control of nematodes under field conditions. To determine the capabilities of this nematicide in field situations it is necessary to have information on its movement and persistence along with achievable dosage levels in the rhizosphere.

#### LITERATURE CITED

1. BERGE, J. B., and A. CUANY. 1972. Activite de l'aldicarb sur les oeufs de *Meloidogyne arenaria*. Acad. D'Agric. de France. p. 371-376.
2. CLARKE, A. J., and A. M. SHEPHERD. 1966. The action of nabam, methamsodium and other sulphur compounds on *Heterodera schachtii* cysts. Ann. Appl. Biol. 57:241-255.
3. DEN OUDEN, H. 1971. De ontwikkeling van *Heterodera rostochiensis* larven in aardappelwortels bij behandeling met systemische nematiciden in het bijzonder aldicarb. Meded. Fac. Landbouwet. Rijksuniv. Gent. 36:889-903.
4. DI SANZO, C. P. 1973. Nematode response to carbofuran. J. Nematol. 5:22-27.
5. DONCASTER, C. C., and A. M. SHEPHERD. 1967. The behavior of second-stage *Heterodera rostochiensis* larvae leading to their emergence from the egg. Nematologica 13:476-478.
6. EVANS, A. A. F., and I. J. THOMASON. 1971. Ethylene dibromide toxicity to adults, larvae and moulting stages of *Aphelenchus avenae*. Nematologica 17:243-254.
7. EVANS, K. 1969. Apparatus for measuring nematode movement. Nematologica 15:433-435.
8. FENWICK, D. W. 1968. A note on the nematicidal properties of Sevin. Trop. Agric., Trinidad 45:125-126.
9. GREEN, C. D. 1966. Orientation of male *Heterodera rostochiensis* Woll. and *H. schachtii* Schm. to



- their females. *Ann. Appl. Biol.* 58:327-339.
10. GREET, D. N., C. D. GREEN, and M. E. POULTON. 1968. Extraction, standardization and assessment of the volatility of the sex attractants of *Heterodera rostochiensis* Woll. and *H. schachtii* Schm. *Ann. Appl. Biol.* 61:511-519.
  11. HAGUE, N. G. M., and B. F. PAIN. 1973. The effect of organophosphorus compounds and oxime carbamates on the potato cyst nematode *Heterodera rostochiensis* Woll. *Pestic. Sci.* 4:459-465.
  12. HOUGH, A., I. J. THOMASON, and W. FARMER. 1975. Behavior of aldicarb in soil as it relates to control of *Heterodera schachtii*. *J. Nematol.* 7:(In press).
  13. KAAI, C. 1972. Systemische nematociden. *Gewasbescherming* 3:33-40.
  14. KONDROLLOCHIS, M., B. F. PAIN, and N. G. M. HAGUE. 1970. Effect of organophosphate and carbamoyloxime nematicides on nematodes. Page 169 in *Proc. 10th International Nematology Symposium of the European Society of Nematologists*. Pescara (Italy) Sept. 8-13, 1970. (Abstr.).
  15. MADDRELL, S. H. P., and S. E. REYNOLDS. 1972. Release of hormones in insects after poisoning with insecticides. *Nature (Lond.)* 23:404-406.
  16. MOJE, W. 1959. Structure and nematocidal activity of allylic and acetylenic halides. *J. Agric. Food Chem.* 7:702-707.
  17. MYERS, R. F. 1973. Assay of nematicidal and nematostatic chemicals using axenic cultures of *Aphelenchoides rutgersi*. *Nematologica* 18:447-457.
  18. NELMES, A. J. 1970. Behavioral responses of *Heterodera rostochiensis* larvae to aldicarb and its sulfoxide and sulfone. *J. Nematol.* 2:223-227.
  19. NELMES, A. J., and S. KEERWEEWAN. 1970. The mechanism of action of aldicarb in controlling root-knot nematodes, *Meloidogyne incognita*, on tomatoes. Pages 182-183 in *Proc. 7th International Congress of Plant Protection, Paris, 21-25 Sept 1970*. (Abstr.).
  20. OSBORNE, P. 1973. The effect of aldicarb on the hatching of *Heterodera rostochiensis* larvae. *Nematologica* 19:7-14.
  21. PEACOCK, F. C. 1961. A note on the attractiveness of roots to plant parasitic nematodes. *Nematologica* 6:85-86.
  22. SPURR, H. W. 1966. Nematode cholinesterases and their inhibition by nematicidal carbamates. *Phytopathology* 56:902-903 (Abstr.).
  23. SPURR, H. W., and A. A. SOUSA. 1966. Pathogenicidal activity of a new carbamoyl oxime insecticide. *Plant Dis. Rep.* 50:424-425.
  24. STEUDEL, W. 1972. Versuche zum Einfluss von Aldicarb auf den Schlupfvorgang bei Zysten von *Heterodera schachtii* nach langerer Einwirkung. *Nematologica* 18:270-274.
  25. VIGLIERCHIO, D. R. 1961. Attraction of parasitic nematodes by plant root emanations. *Phytopathology* 51:136-142.
  26. WEIDEN, M. H. J., H. H. MOOREFIELD, and L. K. PAYNE. 1965. O-(methyl-carbamoyl)oximes: A new class of carbamate insecticide-acaricides. *J. Econ. Entomol.* 58:154-155.
  27. YU, C. C., C. W. KEARNS, and R. L. METCALF. 1972. Acetyl-cholinesterase inhibition by substituted phenyl N-alkyl carbamates. *J. Agric. Food Chem.* 29:537-540.
  28. ZAMBELLI, N., and A. DE LEONARDIS. 1970. A three year field testing against sugar beet nematodes. Pages 185-186 in *Proc. 10th International Nematology Symposium of the European Society of Nematologists*. Pescara (Italy) 8-13 Sept 1970. (Abstr.).