

Nested PCR for Specific Detection and Rapid Identification of Human Picornaviruses

U. KÄMMERER,¹ B. KUNKEL,¹ AND K. KORN^{2*}

Medizinische Klinik I¹ and Institut für Klinische und Molekulare Virologie,² Universität Erlangen-Nürnberg, 91054 Erlangen, Germany

Received 7 May 1993/Returned for modification 3 August 1993/Accepted 26 October 1993

A nested PCR for the detection and rapid identification of human picornaviruses is described. Enteroviruses and rhinoviruses were amplified with the same set of four primers from the 5'-noncoding region. The nested primers allowed the detection of far less than 1 PFU in diluted virus stocks without Southern blot hybridization. In patients with neurological disorders (mainly aseptic meningitis), 43% of 37 specimens (11 of 21 cerebrospinal fluid specimens, 2 of 10 serum specimens, and 3 of 6 stool specimens) were positive by PCR. A total of 21% (10 of 47 specimens) of heart biopsy specimens from patients with dilative cardiomyopathy were PCR positive, whereas 3% (2 of 70 specimens) of control biopsy specimens from patients with coronary artery disease were PCR positive. PCR-amplified fragments from 27 of 29 clinical isolates and 14 of 28 patient samples were successfully serotyped by restriction enzyme digestion. Two specimens were further investigated by direct sequencing of PCR products, leading to the identification of a poliovirus type 3 isolate with a sequence that was highly divergent from previously published sequences.

The family *Picornaviridae* consists of more than 200 distinct serotypes, the majority of which have been isolated from humans and cause a wide variety of diseases (31, 36). The human picornaviruses belong to the genera *Rhinovirus* and *Enterovirus* and include hepatitis A virus, for which a separate genus has been proposed (36). More than 100 serotypes of human rhinoviruses (HRVs) are the major cause of the common cold (5), but investigators have also shown that HRVs can cause more severe infections of the lower respiratory tract, particularly in infants (18, 19). The human enteroviruses (EVs) include the subgroups of polioviruses (PVs; 3 serotypes), coxsackie viruses type A (CAVs; 23 serotypes), coxsackie viruses type B (CBVs; 6 serotypes), echoviruses (32 serotypes), and 4 serotypes of undesignated human EVs (EVs 68 to 71). They can cause many kinds of clinical syndromes such as paralysis, meningitis, myocarditis, and respiratory and gastrointestinal infections (36). Current diagnostic techniques for EVs and HRVs, like virus isolation in tissue culture followed by determination of the serotype by using neutralizing antisera, are often too laborious and time-consuming to achieve virus identification in an adequate period of time. Furthermore, a number of CAVs cannot be isolated in standard tissue cultures and many other human picornaviruses including HRVs are difficult to propagate in cell cultures. Additionally, virus titers in clinical specimens like cerebrospinal fluid (CSF) may be too low for detection of virus by these methods. Hence, there is a need for a sensitive and rapid diagnostic test for picornaviruses. PCR is a highly sensitive method for the detection of small amounts of nucleic acids (33). A number of reports have described the use of PCR for the detection of picornaviruses (3, 7, 8, 12, 16, 17, 23, 24, 26, 29, 30, 34, 40, 42). In the present study, we tried to improve the detection of picornaviruses by PCR and to establish methods for the rapid characterization of amplified fragments.

MATERIALS AND METHODS

Virus stocks. Prototype strains of different serotypes were obtained from several institutions. With the exception of the titration experiments described below, no cell culture amplification of these virus strains was carried out in our laboratories to avoid possible risks of contamination. Clinical isolates had been obtained in the years 1984 to 1988 in our laboratories by using Vero and/or HeLa cells. Serotyping was done with neutralizing antisera to individual serotypes. The number of PFU in virus stocks was determined by serial dilutions in cell culture by using a methylcellulose overlay technique and counting the plaques formed after 24 h of incubation.

Clinical samples. CSF samples, serum samples, and stool suspensions were stored at -20°C . Heart biopsy specimens from patients with dilative cardiomyopathy (DCM) were obtained during cardiac catheterization; samples from patients with coronary artery disease were taken during open heart surgery. All heart biopsy specimens were snap-frozen in liquid nitrogen and were stored at -80°C . None of the patients with DCM had signs of acute myocarditis, and the mean duration of illness was 3 years.

Primer selection. The 5'-noncoding region has been reported to be highly conserved among the picornaviruses (28) and has been used in most PCR studies published to date. We therefore analyzed all completely sequenced picornaviruses in the GenBank and EMBL databases for regions with the highest degrees of homology in the 5'-noncoding region. As a result of this search, two pairs of primers (all 17 nucleotides long) were selected; these primer pairs should allow amplification of specific DNA fragments from all sequenced human and some animal (14) picornaviruses with the exception of hepatitis A virus. Figure 1 displays the localization of the PCR primers used in the present study (coxprims 1 to 4) in comparison with those of a number of primers published previously. The exact nucleotide positions according to the published CBV type 3 sequence (Genbank accession number M33854) are 67 to 83 for coxprim 1, 166 to 182 for coxprim 3, 462 to 446 for coxprim 4, and 561 to 545 for coxprim 2, with the latter two having

* Corresponding author. Mailing address: Institut für Klinische und Molekulare Virologie, Universität Erlangen-Nürnberg, Loschgestrasse 7, 91054 Erlangen, Germany. Phone: +49/9131/854010. Fax: +49/9131/852101.

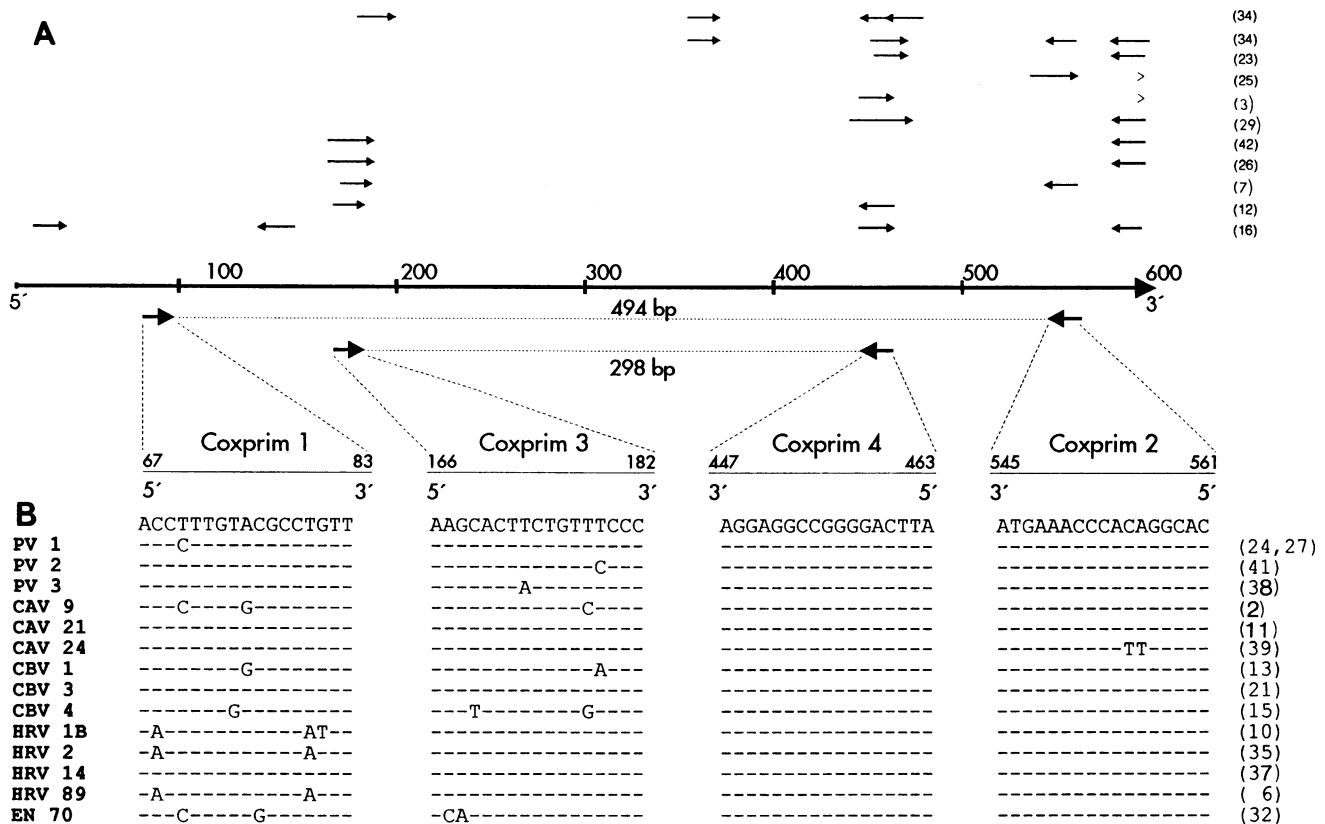

FIG. 1. Sequence and localization of the oligonucleotides used in the present study. (A) Schematic representation of prototype picornavirus genome (CBV type 3 [long arrow]) and locations of previously used primer combinations (above the CBV type 3 genome) and of the primers coxprim 1 to 4 used in the present study. Arrows indicate a 5' to 3' orientation. (B) Comparison of sequences of primers coxprim 1 to 4 with the published sequences of picornavirus genomes. Numbers in parentheses are reference numbers.

negative strand polarity. The lower part of Fig. 1 compares the primer sequences of our primers with those of human picornavirus serotypes for which sequences have been published. All primers (coxprims 1 to 4) were purchased from Pharmacia Biosystems (Freiburg, Germany).

RNA extraction. RNA extraction from cell pellets of virus cultures and from heart biopsy specimens was done by the acid guanidinium thiocyanate method described by Chomczynski and Sacchi (4), but adapted for use with smaller amounts of tissue. Briefly, about 0.1 to 0.4 mg of tissue or cell pellet was dissolved in 300 μ l of solution D (4 M guanidinium thiocyanate, 25 mM sodium citrate [pH 7.0], 0.5% sarcosyl, 0.1 M 2-mercaptoethanol). After adding 30 μ l of 2 M sodium acetate (pH 4.0), 300 μ l of phenol (water saturated), and 60 μ l of chloroform-isoamyl alcohol (49:1) and vigorous vortexing, the mixture was cooled on ice for 15 min and was centrifuged at 10,000 $\times g$ for 30 min, and the RNA was precipitated from the supernatant with 1 volume of isopropanol. RNA from liquid specimens (CSF, serum, cell culture supernatants, stool suspensions) was isolated by sodium dodecyl sulfate-phenol-chloroform extraction exactly as described by Rotbart et al. (30).

cdNA synthesis and PCR. For reverse transcription, the lyophilized RNA was resuspended in a 30- μ l reaction mixture containing 75 mM KCl, 50 mM Tris-HCl (pH 8.3), 3 mM MgCl₂, 10 mM dithiothreitol, 0.3 mM (each) deoxynucleotide triphosphates (Boehringer Mannheim, Mannheim, Germany), 90 ng of primer coxprim 2, and 100 U of Moloney

murine leukemia virus reverse transcriptase (GIBCO-BRL, Eggenstein, Germany), and the mixture was incubated at 37°C for 60 min and was then heated to 95°C for 5 min.

For enzymatic amplification, 5 μ l of the reverse transcription mixture was added to 95 μ l of the PCR mixture containing 50 mM KCl, 10 mM Tris-HCl (pH 8.3), 0.001% (wt/vol) gelatin, 0.25 mM (each) deoxynucleotide triphosphates, 90 ng (each) of primers coxprim 1 and coxprim 2, and 1.5 U of *Taq* DNA polymerase (Perkin-Elmer Cetus, Langen, Germany). Forty cycles of denaturation (94°C, 40 s), annealing (45°C, 30 s), and primer extension (72°C, 45 s) were performed in a thermal cycler. For the nested PCR, 5 μ l of the first PCR mixture was added to 95 μ l of the second PCR mixture (which was the same as first mixture, but with coxprims 3 and 4 instead of coxprims 1 and 2). After another set of 40 cycles under the conditions described above, aliquots of 10 μ l were separated by electrophoresis in 1.5% agarose gels and stained with ethidium bromide. To avoid false-positive PCR results, the precautions for PCR described by Kwok and Higuchi (20) were strictly followed. Negative controls (one for each of four samples) were simultaneously processed in each experiment through all steps from RNA extraction to gel electrophoresis.

RE digestions. Aliquots of 10 μ l of nested PCR products were incubated with 1 to 5 U of restriction enzyme (RE) in a 20- μ l reaction volume by using the buffers recommended by the manufacturers. Samples were incubated at 37°C for 2 h and were then analyzed in 3% agarose gels. REs were

obtained from Boehringer Mannheim, New England Biolabs (Schwalbach, Germany), and Promega (Madison, Wis.).

Sequencing of PCR products. For direct sequencing, 80 μ l of PCR product was purified by using the Qiagen PCR purification kit (Diagen, Düsseldorf, Germany), and the instructions provided with the kit were strictly followed. Sequencing was done with primers coxprim 3 and 4 for nested PCR products and with primers coxprim 1 and 2 for the outer PCR fragments in a standard sequencing reaction (Sequenase sequencing kit; United States Biochemical, Bad Homburg, Germany) by using [32 P]dATP (Amersham, Braunschweig, Germany) as the labelled nucleotide. To improve band resolution, Nonidet P-40 was added to the annealing mixture to a final concentration of 0.01%. All sequencing experiments were done in duplicate in both orientations.

Statistics. For statistical analysis, Fisher's exact test (two-tailed) was used.

RESULTS

To verify whether our nested PCR would allow the detection of strains from all subgroups of human picornaviruses, 33 prototype strains of were tested: PV types 1 to 3; CAV types 5, 7, 9, 16, and 21; CBV types 1 to 6; EV type 71; echovirus types 1 to 9, 11, 12, 22, 24, and 33; and HRV types 1, 2b, 14, and 89. Both sets of primers gave successful amplifications for all these viruses, resulting in DNA bands of the expected size (about 490 bp in the case of the first PCR and nearly 300 bp in the case of the nested PCR). The only exception was echovirus 22, for which smaller bands of about 300 bp after the first PCR and 170 bp after the nested PCR were observed. Uninfected Vero and HeLa cells as well as herpesvirus strains (herpes simplex virus types 1 and 2, cytomegalovirus) and rotavirus did not yield any detectable amplification products (data not shown). To determine the sensitivity of the nested PCR, serial dilutions of a virus stock containing PV type 1 (5×10^6 PFU/ml) were tested. A nested PCR of 100 μ l of sample was positive (visible DNA band on agarose gel) to a dilution of this stock of up to 10^{-8} (Fig. 2). By using a CBV type 3-infected mouse heart, about 50 μ g of tissue (one-sixth volume of a standard heart biopsy specimen) was sufficient to obtain a positive PCR result (data not shown). Finally, for a patient with paralytic poliomyelitis caused by PV type 3, it was possible to detect the virus in as little as 10 μ l of CSF by nested PCR, whereas virus isolation from aliquots of 500 μ l of the same CSF specimen failed.

RE digestions were carried out with prototype strains of the sequenced human picornaviruses (PV types 1 to 3; CAV types 9 and 21; CBV types 1, 3, and 4; HRV types 1b, 2, and 89) as well as CBV types 2, 5, and 6. RE fragment patterns were as predicted for all serotypes for which there were published sequences. Figure 3 shows a part of these results. The blinded examination of 28 serotyped clinical isolates (three PV type 1, five PV type 2, six PV type 3, one CAV type 9, one CAV type 21, two CBV type 1, one CBV type 2, three CBV type 3, three CBV type 4, two CBV type 5, one CBV type 6) by PCR and RE digestion led to the correct identification of the serotype for all viruses with known sequences except one PV type 1 isolate. The lack of sequence data for CBV types 2, 5, and 6 did not allow us to define whether the resulting fragment sizes of the viruses were correct; however, restriction fragment patterns were identical to those of the respective prototype strains that we examined. From these RE digestion data, a flow chart for the

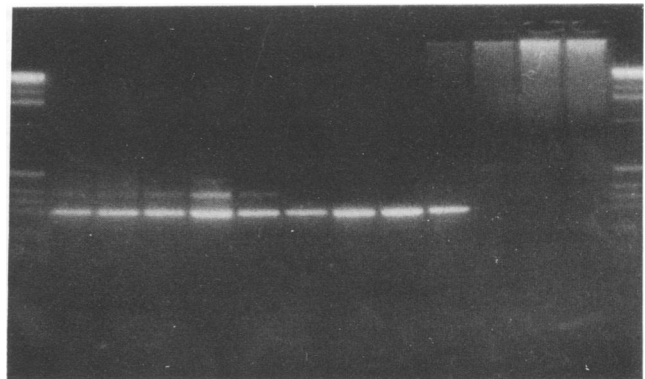

FIG. 2. Determination of the sensitivity of amplification by nested PCR. Serial 10-fold dilutions of a virus stock containing 5×10^6 PFU of PV type 1 were tested by nested PCR. Lane numbers correspond to dilutions (e.g., 0 = 10^0 and 11 = 10^{-11}). M, size marker (1-kb ladder).

identification of a number of picornavirus serotypes could be created, which is displayed in Fig. 4.

In a third step, the nested PCR was applied to the direct testing of patient specimens. Of a total of 37 specimens from patients with neurological disease (aseptic meningitis in 29 patients and paralytic poliomyelitis in 1 patients), 16 (43%) gave a positive PCR result (11 of 21 CSF specimens, 2 of 10 serum specimens, and 3 of 6 fecal specimens). Attempts to isolate viruses in tissue culture were done on five of the PCR-negative and six of the PCR-positive specimens; however, with the exception of the stool sample from the patient with paralytic poliomyelitis, all cultures were negative.

Among 117 heart tissue specimens tested, 12 (10%) yielded positive PCR results. The positivity rate in samples from patients with DCM was 21% (10 of 47 specimens), whereas it was 3% (2 of 70 specimens) in biopsy specimens from

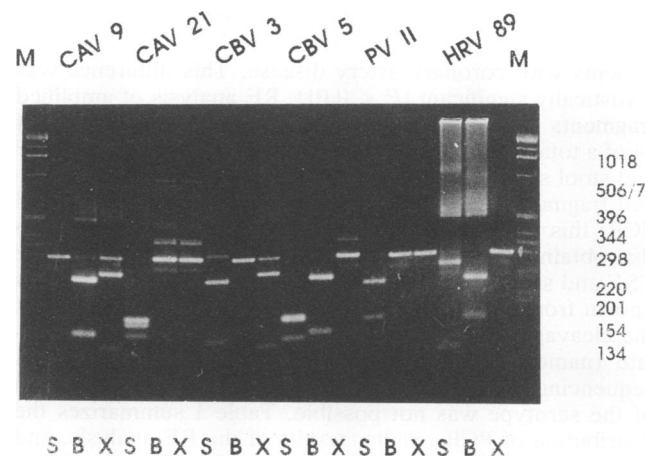

FIG. 3. RE digestion of nested PCR products from four different prototype strains with three restriction enzymes (S, *StyI*; B, *BglI*; X, *XmnI*). M, size marker (1-kb ladder). In some of the lanes, additional submolar bands are visible. These bands are a result of incomplete cleavage (lane X, CAV type 9; lanes S and X, CBV type 3) or to the presence of first-round PCR product (lane CAV type 9) B, or to products derived from one nested and one outer primer (lanes B and X, CAV 21; lane X, CBV 5).

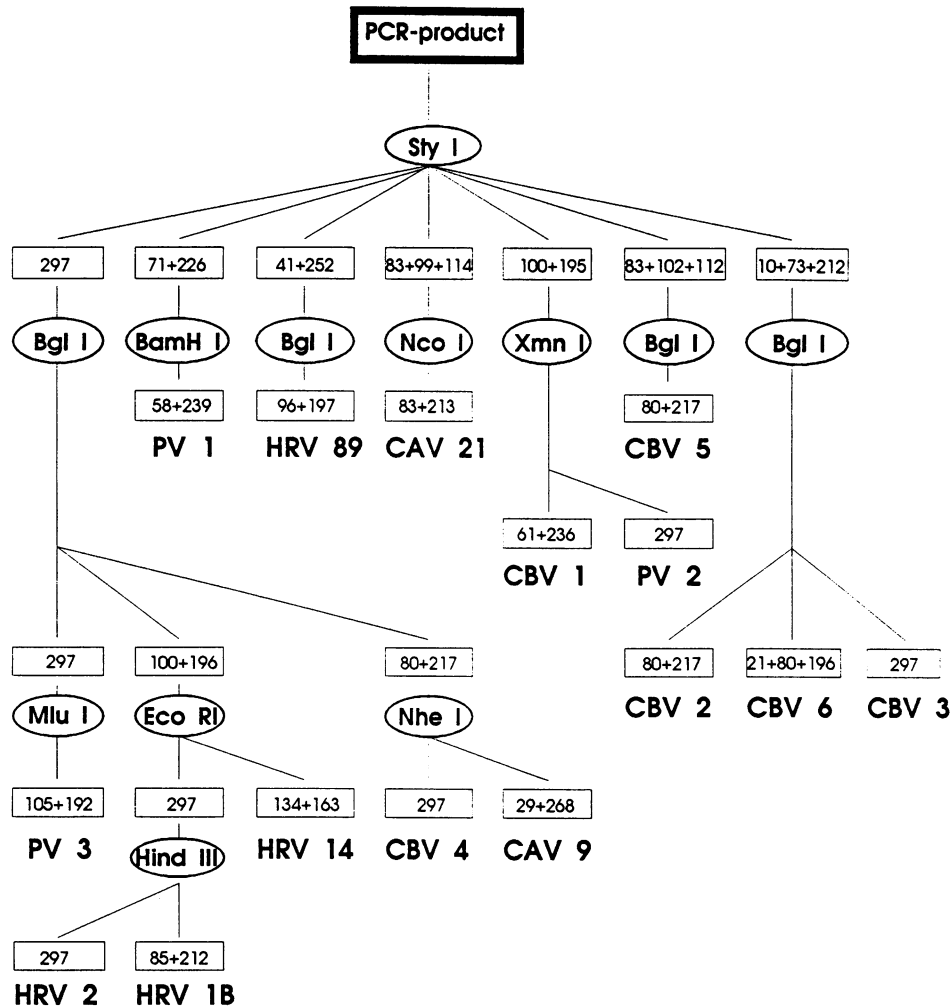

FIG. 4. Flow chart for RE digestions for serotyping of nested PCR products. Oval frames, REs used; rectangular frames, sizes (in base pairs) of DNA fragments resulting from digestion with the respective RE.

patients with coronary artery disease. This difference was statistically significant ($P < 0.01$). RE analysis of amplified fragments gave conclusive information on the serotypes of 14 of a total of 28 PCR-positive samples. Two samples (CSF and stool samples from the same patient) showed an amplified fragment that was smaller than expected in the nested PCR; this fragment was similar but not identical in size to that obtained with an echovirus type 22 strain. For another CSF and stool specimen pair, the serotype (PV type 3) was known from positive virus cultures of stool specimens, but the cleavage pattern was inconclusive. Therefore, this isolate (named ER92-1) was further investigated by direct sequencing. For the remaining 10 specimens, identification of the serotype was not possible. Table 1 summarizes the distribution of PCR results, results of the RE analysis, and additional information that was available for all clinical samples tested.

Sequencing of PCR products was done for isolate ER92-1 described above and, for comparison, for one of the clinical PV type 3 isolates (named ER86-1) used for the establishment of the restriction scheme. The sequence determined from the outer PCR fragment of virus cultured from a stool sample containing isolate ER92-1 showed 42 mutations to

PV type 3 prototype strain Leon 37 (17) between nucleotides 201 and 560. Twenty-two of these mutations were also shown to be present in the sequence of a PV type 3 isolate obtained during the 1984 epidemic in Finland (9). These base exchanges also affect the *MluI* recognition site used for typing. Sequencing of the nested PCR fragment directly amplified from the CSF of the patient infected with isolate ER92-1 gave results identical to those for the stool isolate for the 252 bases that were readable. For clinical isolate ER86-1, only 8 base exchanges were seen in a total of 360 bases sequenced from the outer PCR fragment. Both sequences showed a nucleotide C at position 472, which has been reported to be important for the virulence of PV type 3 strains (22).

DISCUSSION

We described a nested PCR method that allows for the rapid and sensitive detection of human EVs as well as HRVs. PCR detection of EVs (3, 16, 23, 26, 29, 30, 34, 42), HRVs (7, 8, 40), or both (12, 17, 25) has already been described by a number of other investigators. However, to achieve a sufficient degree of sensitivity and specificity, most

TABLE 1. Results for clinical samples tested for picornaviruses by nested PCR^a

Specimen	No. of samples	No. (%) of samples PCR positive	RE analysis/sequencing result (no. of specimens)	Comments
CSF	21	11 (52)	CBV type 1 (1) CBV type 3 (2) CBV type 4 (1) CBV type 5 (1) Smaller fragment, similar to echovirus type 22 (1) PV type 3 (atypical RE pattern, sequenced) (1) Unclear (4)	Elevated antibodies to CBV type 3 in serum Elevated serum antibodies to CBV type 5 Stool also positive (see below) Paralytic poliomyelitis; stool also positive (see below)
Serum	10	2 (20)	CBV type 3 (1) CBV type 5 (1)	No CSF available CSF negative by PCR
Stool	6	3 (50)	CAV type 21 (1) Smaller fragment, similar to echovirus type 22 (1) PV type 3 (atypical RE pattern, sequenced) (1)	“Hand-foot and mouth” disease with meningeal signs CSF also positive (see above) CSF also positive (see above)
Myocardial biopsy (DCM)	47	10 (21)	CBV type 3 (5) Unclear (5)	
Myocardial biopsy (CAD)	70	2 (3)	CBV type 4 (1) Unclear (1)	

^a Unless stated otherwise, the clinical illness was aseptic meningitis. Abbreviations: DCM, dilative cardiomyopathy; CAD, coronary artery disease.

of those investigators used hybridization methods, which are time-consuming and often require the use of radioactively labelled probes as well (3, 12, 16, 17, 26, 29, 30, 42). Only recently, one report describing a nested PCR was published (34); however, that was a rather preliminary report, with only a small number of clinical samples being tested. In that study (34) as well as in our study, it could be shown that with a nested PCR approach, a very high level of sensitivity can be obtained by agarose gel electrophoresis of the nested PCR product alone. If one assumes a ratio of about 1,000 virus particles per PFU (31), a sensitivity of less than 10 genome equivalents can be calculated from our dilution experiments, which is in the same range as that described by Severini et al. (34). Because of the requirement of four liquid hybridizations, a nested PCR also offers a degree of specificity that can otherwise only be reached by Southern blot hybridization of PCR products. The additional problems of contamination that might occur by the second amplification step could be overcome with the use of different rooms and equipment for (i) the preparation of reagent mixtures, (ii) RNA extraction and cDNA synthesis, (iii) thermocycling and nested PCR pipetting, and (iv) analysis of the PCR products (agarose gel electrophoresis, RE digestion, sequencing). A further advantage of the nested PCR is that it yields high amounts of amplified DNA from, for example, less than 50 µl of a CSF sample or a standard heart biopsy specimen. This makes rapid characterization of the amplified fragments by a series of RE digestions possible. Applying a total of nine restriction enzymes with six-base recognition sequences, we could successfully identify the serotype in 27 of 29 clinical isolates of the PV, CAV, and CBV serotypes.

The selection of primers used for the nested PCR described here allows for the detection of PV, CAV, CBV, echovirus, and even rhinovirus serotypes. Thus, although complete sequences are available for less than 20 serotypes

of human picornaviruses and although only a limited number of prototype strains and serotyped clinical isolates were tested in the present study, one can assume that this nested PCR will be suitable for the detection of all groups of human picornaviruses with the exception of hepatitis A virus, which has a sequence highly divergent from those of the other picornaviruses. The broad range of viruses that could be amplified as described here allows the application of the nested PCR method to a variety of clinical problems. The possibility of rapid identification of a number of sequenced prototype strains can be exploited to exclude contamination problems caused by high-titer positive controls, if a serotype that is not expected in the respective clinical setting is used as a positive control. In the experiments with clinical samples described here, we used a rhinovirus in the study of neurological disorders and a poliovirus for the heart biopsy specimens. Our results show that the nested PCR described here can be very useful for the investigation of cases of aseptic meningitis. For CSF samples from patients with such infections, the positivity rate was about 50%, despite negative results of virus cultures, which were performed when enough material was available. In a significant number of these cases, we could also delineate by RE analysis which serotype might be implicated. In two cases, serological results confirmed the results of RE analysis, since elevated titers of neutralizing antibodies against the same serotype were found in the sera of these patients. Unfortunately, direct confirmation by virus culture and serotyping was not possible, since for the sample from the only patient from which virus could be isolated, the restriction enzyme pattern was inconclusive. Nevertheless, the nested PCR approach described here is a valuable tool in investigating cases of aseptic meningitis, since diagnosis by virus culture may be hampered by the availability of very small amounts of CSF only, inactivation of virus infectivity because of delays in

transport, or the poor growth of many CAV and echovirus serotypes in cell culture. The usefulness of the serotyping of PCR products by RE digestion described here will be further investigated by the incorporation of higher numbers of serotyped clinical isolates differing in time of isolation and geographical origin. Sequence information on more serotypes of picornaviruses may also help to increase the number of conclusive RE digestion patterns from clinical samples over the 50% reported here.

The second clinical problem that we addressed in the present study is the association of EVs (particularly CBV serotypes) with cases of DCM. A number of PCR studies have been published about this issue (1, 16, 23, 26, 34, 42). In most of those studies (16, 23, 34, 42), the rate of PCR-positive samples was between 10 and 20%; however, no control specimens from patients with diseases other than DCM or myocarditis were incorporated in those studies. In contrast, the two studies that tested more than 100 specimens (1, 26) detected EV nucleic acid in 30 and 55% of all samples, respectively, with a positivity rate of 39% even for control samples in the latter study. Identification of the amplified serotype was not attempted in any of those studies; however, in one study (34) the two positive samples could be classified as belonging to the CBV subgroup of EVs. With our highly sensitive PCR approach, we could identify picornavirus nucleic acid in only a small percentage (3%) of control biopsy specimens but could identify picornavirus nucleic acid at a sevenfold higher rate (21%) in biopsy specimens from patients with DCM. Interestingly, five of the PCR-positive biopsy specimens from patients with DCM yielded restriction fragments identical to those of the CBV type 3 prototype strain and clinical isolates, whereas the remaining five PCR-positive samples gave inconclusive RE patterns. Additional analysis of these 10 PCR products with the four-base recognition site restriction enzymes *Hae*III, *Sau*3AI, and *Taq*I (data not shown) showed individual patterns for all 10 of these samples, ruling out the possibility of contamination. Sequence analysis of these samples from patients with DCM and comparison with CBV type 3 and other picornavirus strains from different sources are under way and may be helpful for the further elucidation of the role of picornaviruses in DCM.

ACKNOWLEDGMENTS

We thank B. Böhlig (Berlin, Germany), F. Harms (Würzburg, Germany), and R. Müller (Erlangen, Germany) for providing EV strains, B. Rosenwirth (Vienna, Austria) for providing the rhinovirus strains, R. Kandolf (Tübingen, Germany) for the CBV type 3-infected mouse heart, and B. Fleckenstein for helpful discussions.

This work was supported by a grant from the Johannes und Frieda Marohn-Stiftung.

REFERENCES

1. Archard, L. C., C. A. Freeke, P. J. Richardson, B. Meany, E. G. J. Olsen, P. Morgan-Chapner, M. L. Rose, P. Taylor, N. R. Banner, M. H. Yacoub, and N. E. Bowles. 1987. Persistence of enteroviral RNA in dilated cardiomyopathy: a progression from myocarditis, p. 349–362. *In* H. P. Schultheiss (ed.), *New concepts in viral heart disease*. Springer-Verlag, Berlin.
2. Chang, K. H., P. Auvinen, T. Hyypiä, and G. Stanway. 1989. The nucleotide sequence of coxsackievirus A9; implications for receptor binding and enterovirus classification. *J. Gen. Virol.* **70**:3269–3280.
3. Chapman, N. M., S. Tracy, C. J. Gauntt, and U. Fortmueller. 1990. Molecular detection and identification of enteroviruses using enzymatic amplification and nucleic acid hybridisation. *J. Clin. Microbiol.* **28**:843–850.
4. Chomczynski, P., and N. Sacchi. 1987. Single-step method of RNA-isolation by acid guanidinium thiocyanate-phenol-chloroform extraction. *Anal. Biochem.* **162**:156–159.
5. Couch, R. B. 1984. The common cold: control? *J. Infect. Dis.* **150**:167–173.
6. Duechler, M., T. Skern, W. Sommergruber, C. Neubauer, P. Gruendler, I. Fogy, D. Blaas, and E. Kuechler. 1987. Evolutionary relationships within the human rhinovirus genus: comparison of serotypes 89, 2 and 14. *Proc. Natl. Acad. Sci. USA* **84**:2605–2609.
7. Gama, R. E., P. R. Horsnell, P. J. Hughes, C. North, C. B. Bruce, W. Al-Nakib, and G. Stanway. 1989. Amplification of rhinovirus specific nucleic acids from clinical samples using the polymerase chain reaction. *J. Med. Virol.* **28**:73–77.
8. Gama, R. E., P. J. Hughes, C. B. Bruce, and G. Stanway. 1988. Polymerase chain reaction amplification of rhinovirus nucleic acids from clinical material. *Nucleic Acids Res.* **16**:9346.
9. Hughes, P. J., D. M. A. Evans, P. D. Minor, G. C. Schild, J. W. Almond, and G. Stanway. 1986. The nucleotide sequence of a type 3 poliovirus isolated during a recent outbreak of poliomyelitis in Finland. *J. Gen. Virol.* **67**:2093–2102.
10. Hughes, P. J., C. North, C. H. Jellis, P. D. Minor, and G. Stanway. 1988. The nucleotide sequence of human rhinovirus 1B: molecular relationships within the rhinovirus genus. *J. Gen. Virol.* **69**:49–58.
11. Hughes, P. J., C. North, P. D. Minor, and G. Stanway. 1989. The complete nucleotide sequence of coxsackievirus A 21. *J. Gen. Virol.* **70**:2943–2952.
12. Hyypiä, T., P. Auvinen, and M. Maaronen. 1989. Polymerase chain reaction for human picornaviruses. *J. Gen. Virol.* **70**:3261–3268.
13. Iizuka, N., S. Kuge, and A. Nomoto. 1987. Complete nucleotide sequence of the genome of coxsackievirus B1. *Virology* **156**:64–73.
14. Inoue, T., T. Suzuki, and K. Sekiguchi. 1989. The complete nucleotide sequence of swine vesicular disease virus. *J. Gen. Virol.* **70**:919–934.
15. Jenkins, O., J. D. Booth, P. D. Minor, and J. W. Almond. 1987. The complete nucleotide sequence of coxsackievirus B4 and its comparison to other members of the picornaviridae. *J. Gen. Virol.* **68**:1835–1848.
16. Jin, O., M. J. Sole, J. W. Butany, W.-K. Chia, P. R. McLaughlin, P. Liu, and C.-C. Liew. 1990. Detection of enterovirus RNA in myocardial biopsies from patients with myocarditis and cardiomyopathy using gene amplification by polymerase chain reaction. *Circulation* **82**:8–16.
17. Johnston, S. L., G. Sanderson, P. K. Pattemore, S. Smith, P. G. Bardin, C. B. Bruce, P. R. Lambden, D. A. J. Tyrrell, and S. T. Holgate. 1993. Use of polymerase chain reaction for diagnosis of picornavirus infection in subjects with and without respiratory symptoms. *J. Clin. Microbiol.* **31**:111–117.
18. Kellner, G., T. Popow-Kraupp, M. Kundi, C. Binder, H. Wallner, and C. Kunz. 1988. Contribution of rhinoviruses to respiratory viral infections in childhood: a prospective study in a mainly hospitalized infant population. *J. Med. Virol.* **25**:455–469.
19. Krilov, L., L. Pierik, E. Keller, K. Mahan, D. Watson, M. Hirsch, V. Hamparian, and K. McIntosh. 1986. The association of rhinoviruses with lower respiratory tract disease in hospitalized patients. *J. Med. Virol.* **19**:345–352.
20. Kwok, S., and R. Higuchi. 1989. Avoiding false positives with PCR. *Nature (London)* **339**:237–238.
21. Lindberg, A. M., P. O. K. Stalhandske, and U. Pettersson. 1987. Genome of coxsackievirus B3. *Virology* **156**:50–63.
22. Minor, P. D. 1992. The molecular biology of polio vaccines. *J. Gen. Virol.* **73**:3065–3077.
23. Muir, P., F. Nicholson, M. Jhetam, S. Neogi, and J. E. Banatvala. 1993. Rapid diagnosis of enterovirus infection by magnetic bead extraction and polymerase chain reaction detection of enterovirus RNA in clinical specimens. *J. Clin. Microbiol.* **31**:31–38.
24. Nomoto, A., T. Omata, H. Toyoda, S. Kuge, H. Horie, Y. Kataoka, Y. Genba, Y. Nakano, and N. Imura. 1982. Complete

- nucleotide sequence of the attenuated poliovirus Sabin 1 strain genome. *Proc. Natl. Acad. Sci. USA* **79**:5793-5797.
25. Olive, D. M., S. Al-Mufti, W. Al-Mulla, M. A. Khan, A. Pasca, G. Stanway, and W. Al-Nakib. 1990. Detection and differentiation of picornaviruses in clinical samples following genomic amplification. *J. Gen. Virol.* **71**:2141-2147.
 26. Petitjean, J., H. Kopecka, F. Freymuth, J. M. Langlard, P. Scanu, F. Galateau, J. B. Bouhour, M. Ferriere, P. Charbonneau, and M. Komajda. 1992. Detection of enteroviruses in endomyocardial biopsy by molecular approach. *J. Med. Virol.* **37**:76-82.
 27. Racaniello, V. R., and D. Baltimore. 1981. Molecular cloning of poliovirus cDNA and determination of the complete nucleotide sequence of the viral genome. *Proc. Natl. Acad. Sci. USA* **78**:4887-4891.
 28. Rivera, V. M., J. D. Welsh, and J. V. Maizel, Jr. 1988. Comparative sequence analysis of the 5' noncoding region of the enteroviruses and rhinoviruses. *Virology* **165**:42-50.
 29. Rotbart, H. A. 1990. Enzymatic RNA amplification of the enteroviruses. *J. Clin. Microbiol.* **28**:438-442.
 30. Rotbart, H. A., J. P. Kinsella, and R. L. Wasserman. 1990. Persistent enterovirus infection in culture-negative meningoencephalitis: demonstration by enzymatic RNA amplification. *J. Infect. Dis.* **161**:787-791.
 31. Rueckert, R. R. 1990. Picornaviridae and their replication, *In* B. N. Fields, D. M. Knipe, et al. (ed.), *Virology*, 2nd ed. Raven Press, New York.
 32. Ryan, M. D., O. Jenkins, P. J. Hughes, A. Brown, N. J. Knowles, D. Booth, P. D. Minor, and J. W. Almond. 1990. The complete nucleotide sequence of enterovirus type 70: relationships with other members of the picornaviridae. *J. Gen. Virol.* **71**:2291-2299.
 33. Saiki, R. K., D. H. Gelfand, S. Stoffel, S. J. Scharf, R. Higuchi, G. T. Horn, K. B. Mullis, and H. A. Erlich. 1988. Primer-directed enzymatic amplification of DNA with a thermostable DNA polymerase. *Science* **239**:487-491.
 34. Severini, G. M., L. Mestroni, A. Falaschi, F. Camerini, and M. Giacca. 1993. Nested polymerase chain reaction for high sensitivity detection of enteroviral RNA in biological samples. *J. Clin. Microbiol.* **31**:1345-1349.
 35. Skern, T., W. Sommergruber, D. Blaas, P. Gruendler, F. Fraundorfer, C. Pieler, J. Fogy, and E. Kuechler. 1985. Human rhinovirus 2: complete nucleotide sequence and proteolytic processing signals in the capsid protein region. *Nucleic Acids Res.* **13**:2111-2126.
 36. Stanway, G. 1990. Structure, function and evolution of picornaviruses. *J. Gen. Virol.* **71**:2483-2501.
 37. Stanway, G., P. J. Hughes, R. C. Mountford, P. D. Minor, and J. W. Almond. 1984. The complete nucleotide sequence of a common cold virus: human rhinovirus 14. *Nucleic Acids Res.* **12**:7859-7875.
 38. Stanway, G., P. J. Hughes, R. C. Mountford, P. Reeve, P. D. Minor, G. C. Schild, and J. W. Almond. 1984. Comparison of the complete nucleotide sequences of the genomes of the neurovirulent poliovirus P3/Leon/37 and its attenuated Sabin vaccine derivative P3/Leon 12a,b. *Proc. Natl. Acad. Sci. USA* **81**:1539-1543.
 39. Supanaranod, K., N. Takeda, and S. Yamazaki. 1992. The complete nucleotide sequence of a variant of coxsackievirus A24, an agent causing acute haemorrhagic conjunctivitis. *Virus Genes* **6**:149-158.
 40. Torgersen, H., T. Skern, and D. Blaas. 1989. Typing of human rhinoviruses based on sequence variations in the 5'-noncoding region. *J. Gen. Virol.* **70**:3111-3116.
 41. Toyoda, H., M. Kohara, Y. Kataoka, T. Suganuma, T. Omata, N. Imura, and A. Nomoto. 1984. Complete nucleotide sequences of all three poliovirus serotype genomes. *J. Mol. Biol.* **174**:561-585.
 42. Zoll, G. J., W. J. G. Melchers, H. Kopecka, G. Jambroes, H. J. A. van der Poel, and J. M. D. Galama. 1991. General primer-mediated polymerase chain reaction for detection of enteroviruses: application for diagnostic routine and persistent infection. *J. Clin. Microbiol.* **30**:160-165.