

Supporting Information:

**The interface of an array of five capillaries with an array
of one-nanoliter wells for high-resolution electrophoretic analysis
as an approach to high-throughput chemical cytometry**

Anna Boardman¹, Sarah C. McQuaide², Cuiru Zhu^{1,3}, Colin Whitmore¹,

and Norman J. Dovichi¹

1-Department of Chemistry, University of Washington, Seattle WA 98195-1700 USA

2-Department of Electrical Engineering, University of Washington, Seattle WA 98195-
1700 USA

3-present address – Children's Hospital, 200 Henry Clay Ave, New Orleans, LA 70118
USA

An exploded view of the injector is shown as Figure S1. The capillaries are positioned in the injection block that is composed of four horizontal layers (2, 6, 4, 66), made of Plexiglas. The pieces are held together with two metal pins (10) and five 4-40 screws (12). The top two pieces have seven through holes while the bottom two layers have blind holes for the pins and five threaded blind holes for the screws. The top three pieces (2, 6, 4) have a 0.036" through hole (14) for the five aligning tubes (65) where five separation capillaries (18) are threaded. The bottom piece (66) has five 0.014" through holes for each aligning tube.

The Pt electrode (22) is soldered to the exposed piece (24) of the high voltage wire (26). The electrode is bent to allow the cable to be attached on the back of the injection block. To accommodate the electrode and cable, grooves are milled into the top two pieces (2, 6).

Piece 4 has a gas channel (34) milled from the back side of the Plexiglas piece to the opening (36) on the lower surface. Fittings and tubing (38) allow for nitrogen gas to flow to the open ends of the capillaries. Pieces 4 and 66 both have two blind holes to accommodate for the two pins in the vial holder (52).

The vial holder (52) has a hole (54) and two pins (48) on the top surface. The hole holds a small vial and has a lip that holds an O-ring (56). The O-ring forms a seal to ensure adequate gas purging once it is fastened to the top four pieces.

Once the top four pieces are assembled, two clamps (58) are attached to both sides. The vial holder is secured to the top pieces using the clamps and the two retaining knobs (62) attached to the sides of the vial holder with the screws (64).

Figure S1-diagram of the interface that holds the capillaries.

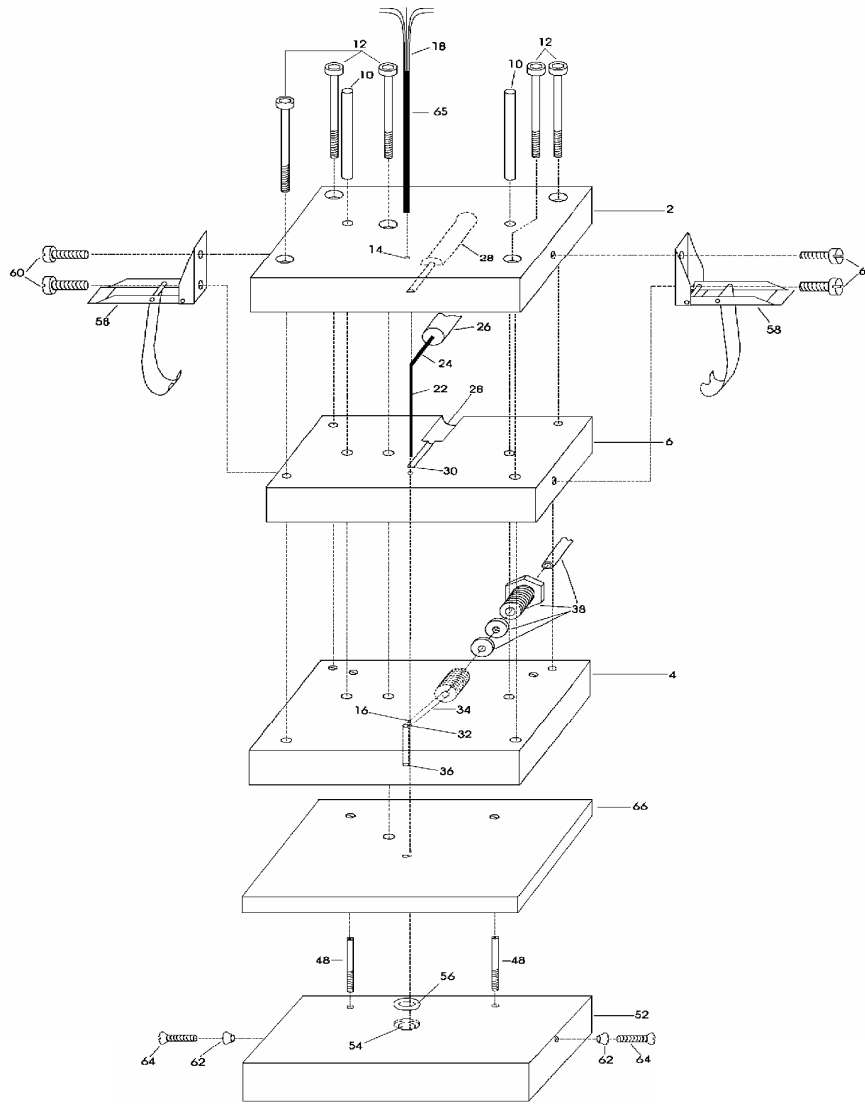

Figure S2 – photograph of a single cell in a well (left), a capillary placed in the well (center), and the well after the cell has been aspirated (right).

