

6 Supplementary Materials

The following supplementary materials complement “A simple method for calibrating force plates and force treadmills using an instrumented pole” (Collins, Adamczyk, and Kuo, *Gait & Posture*, 2008) and are intended to provide interested readers with more detailed information to be used in performing the PILS calibration in their own laboratories. The following pages contain:

- (1) A photograph of the instrumented pole in assembled form,
- (2) Engineering drawings of the custom aluminum parts used to incorporate an axial load cell into the instrumented pole, and
- (3) A file containing MATLAB code for compiling the reference (R) and signal (S) matrices from raw data and calculating the PILS calibration matrix (C) described in the accompanying manuscript.



Figure 4. Photograph of the instrumented pole used for force plate calibration. The pole allows arbitrary directions and magnitudes of force to be manually applied to the force plate in arbitrary locations, using a motion capture system to record kinematics. The pole (Motion Lab Systems MTD-2) is modified to include an axial load cell (LC202-3K, OMEGA Engineering, Inc., Stamford, CT). The load cell can be seen in the foreground, in between two custom-made aluminum components (described in the following pages).

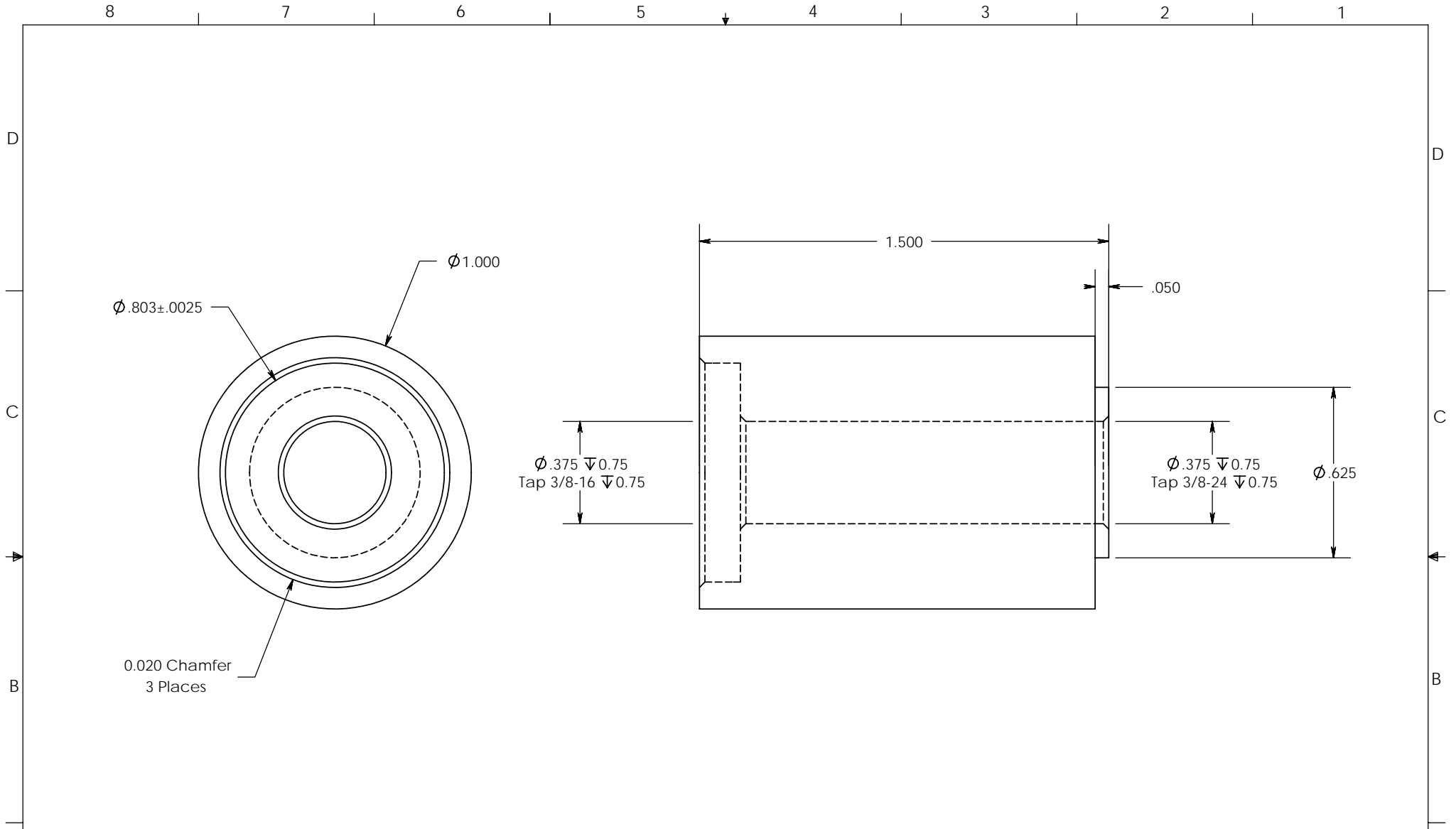

Supplementary Drawing for: Collins et. al. (2007) Gait & Posture

UNLESS OTHERWISE SPECIFIED DIMENSIONS ARE IN INCHES TOLERANCES ARE:		CUSTOMER		PROJECT	
LINEAR	ANGULAR	CAD FILE			
XX ± 0.01	X° ± 1.0°	Point Interface			
.XXX ± 0.005	X° ± 0.5°				
XXXX ± 0.001	.XX° ± 0.1°	DESCRIPTION			
MATERIAL		DWG. NO.			
6061 Aluminum		REV. 1			
FINISH		DWG. SIZE A SCALE 2:1 SHEET 1 OF 1			
NO SHARP EDGES					
QUANTITY					
1					
DRAWN SHC					
DATE 6-14-2006					

REV.	MADE BY	DATE	DESCRIPTION

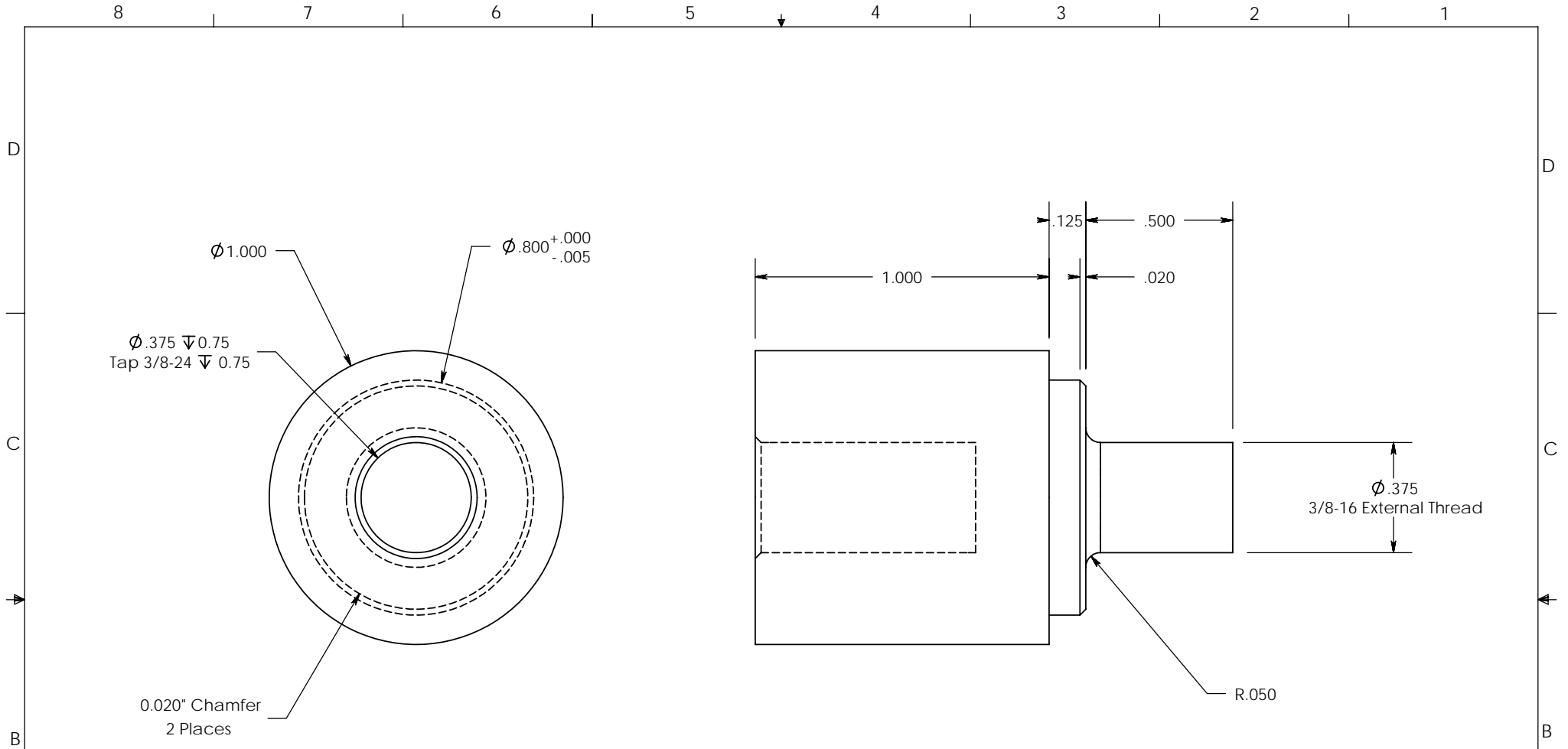

Supplementary Drawing for: Collins et. al. (2007) Gait & Posture

UNLESS OTHERWISE SPECIFIED DIMENSIONS ARE IN INCHES TOLERANCES ARE:		CUSTOMER		PROJECT	
LINEAR	ANGULAR	CAD FILE			
XX ± 0.01	X° ± 1.0°	Rod Interface			
.XXX ± 0.005	X° ± 0.5°				
XXXX ± 0.001	.XX° ± 0.1°				
MATERIAL		DESCRIPTION			
6061 Aluminum		NO SHARP EDGES			
FINISH		QUANTITY		DWG. NO.	
NO SHARP EDGES		1		REV. 1	
DRAWN		DATE		DWG. SIZE	
SHC		6-14-2006		A	
		SCALE		SHEET	
		2:1		1 OF 1	

REV.	MADE BY	DATE	DESCRIPTION