

Supplemental Data

AJHG, Volume 85

Common Variants in the Trichohyalin Gene

Are Associated with Straight Hair in Europeans

Sarah E. Medland, Dale R. Nyholt, Jodie N. Painter, Brian P. McEvoy, Allan F. McRae, Gu Zhu, Scott D. Gordon, Manuel A.R. Ferreira, Margaret J. Wright, Anjali K. Henders, Megan J. Campbell, David L. Duffy, Narelle K. Hansell, Stuart Macgregor, Wendy S. Slutske, Andrew C. Heath, Grant W. Montgomery, and Nicholas G. Martin

Figure S1: Flowchart Showing the Overlap of Participants between Genotyping Projects.

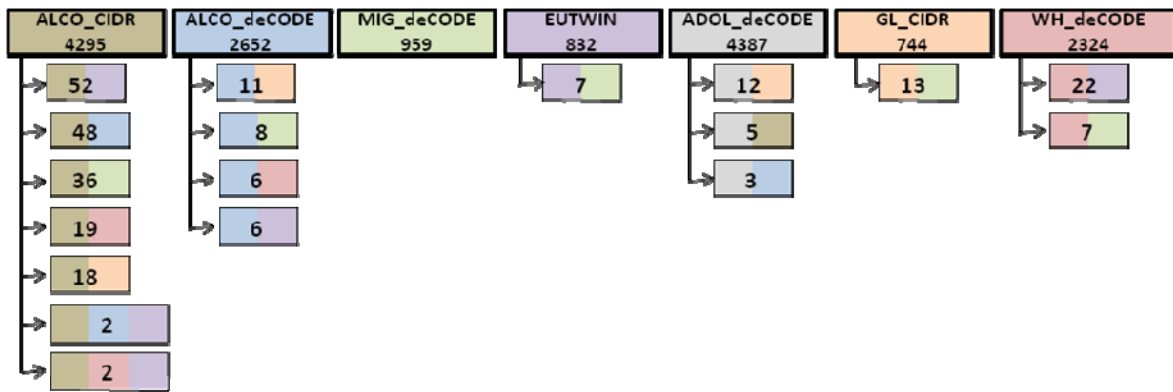

Colour codes are used to indicate the projects; the numbers in the title boxes indicated the number of non-duplicate individuals in each genotyping project; the underlying boxes demonstrate the number of individuals typed in multiple projects, which the colour coding indicating the sources of the genotyping. Following the QC of the individual projects the data from the seven waves of genotyping were integrated. A number of samples were duplicated between the various genotyping projects to allow for cross project QC. After integration of the data sets the data were screened for missingness within individuals (>5% taking into account the number of SNPs that were genotyped for each individual), pedigree and sex errors, and Mendelian errors (genotypes for all family members for a given SNP were removed on detection of errors). Following QC, in cases where one individual from a monozygotic twin pair had been genotyped, duplicate genotypes were assigned to the ungenotyped co-twin, this resulted in a final sample size of 16,507 individuals.

Figure S2: Principal Component Analysis of Australians and 16 Global Populations

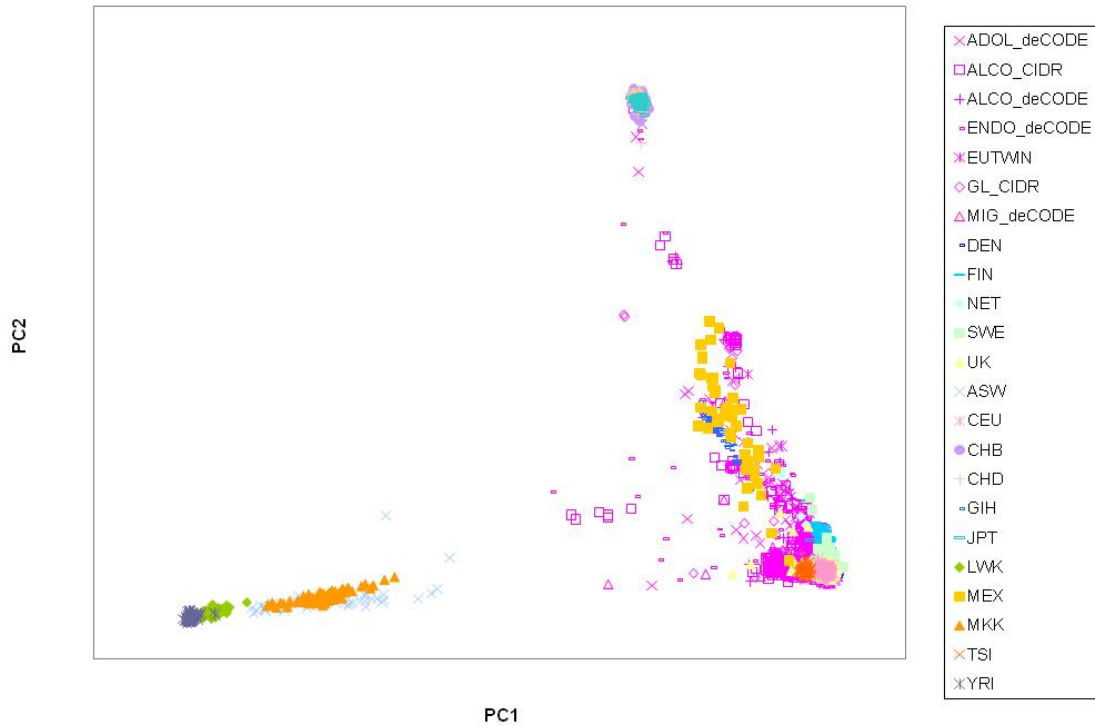

The PC1 and PC2 values for each individual are plotted against each other. Abbreviations are listed in Supplementary Tables 1 and 3. PCA was conducted using the autosomal SNPs that were genotyped in common between all Australian cohorts, HM3 and GEUT populations with the further proviso that SNP missing rates were < 2.5% in all individual cohorts and populations. A total of 225,455 SNPs fulfilled these requirements. The EIGENSOFT package was used to conduct the PCA². Only those individuals in the 16 populations (n = 2317) were included in the initial PCA used to generate the top10 Eigenvectors or Principal components (PCs). The Australian data was then projected onto this 'genetic space' background. PC1 largely reflects the difference between Africans and non-Africans while PC2 separates East Asians from others. Further PCs show substantially lower values than those associated with PC1 and PC2. The Australian individuals cluster with Europeans as expected. However, several show evidence of African or Asian ancestry. We used the non-Australian European populations (CEU, TSI, NET, UK, SWE, FIN and DEN) to calculate mean reference PC1 and PC2 scores. Any Australian individual more than 6 standard deviations from this mean was deemed to be an ancestry outlier. Any full siblings of offspring of excluded individuals were also excluded. A total of 277 Australian individuals were excluded as outliers (1.8% of the original sample) and an additional 70 individuals were excluded as relatives of an excluded individual.

Figure S3: QQ-Plots of the Mx Results from the a) Adolescent sample ($\lambda=0.98$), b) Adult S1 sample ($\lambda=1.022$), c) Adult S2 sample ($\lambda=1.021$), and d) the meta-analysis of the 3 sets of Mx results. Note triangles are used in panel d to indicate truncated data points.

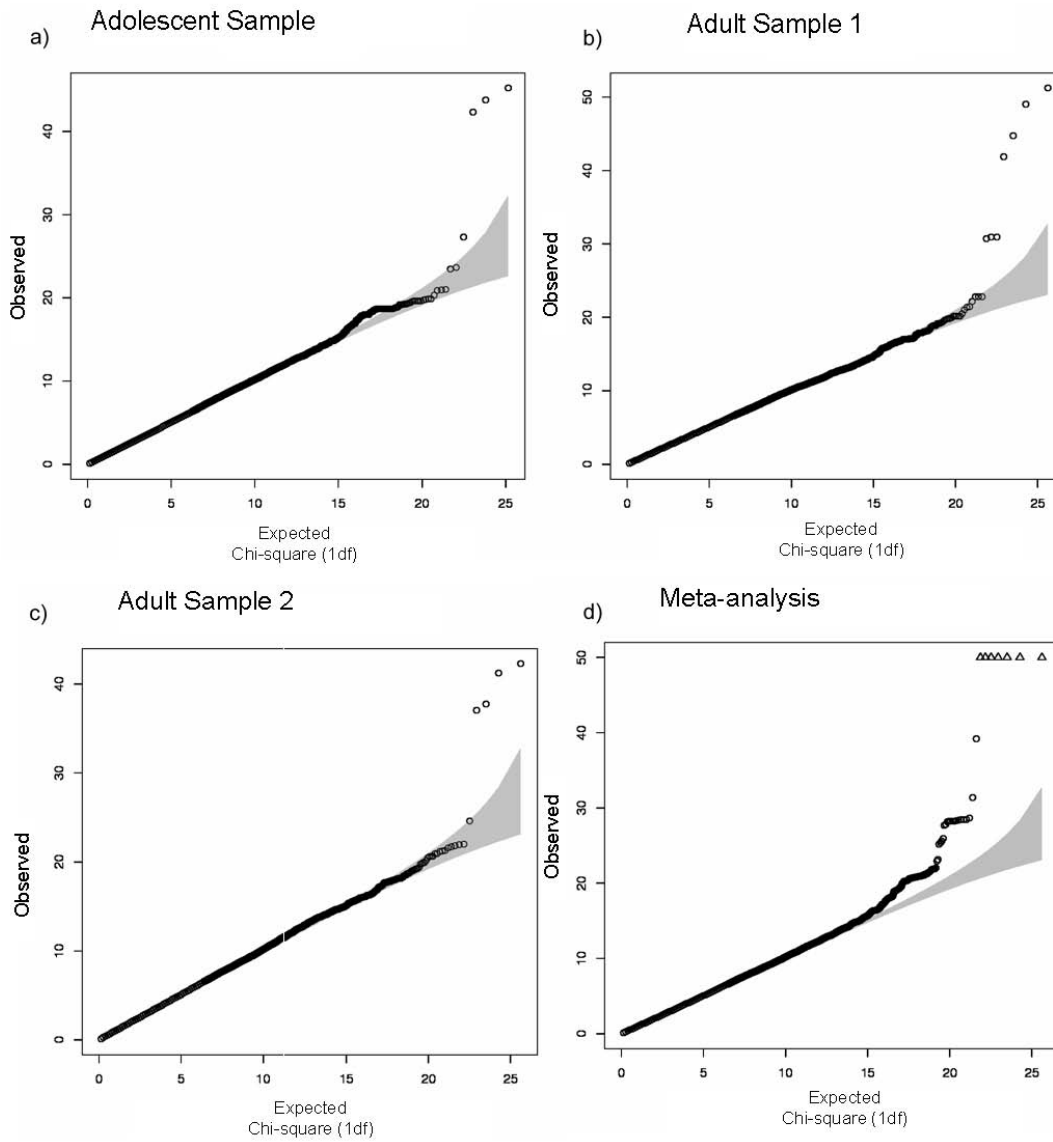

Figure S4: Panel 1, Mx results from the Adolescent sample; Panel 2, Mx results from the Adult S1 sample; Panel 3, Mx results from the Adult S2 sample; Panel 4, Results from the Metal N weighted meta-analysis of the 3 samples; Panel 5, Results from the Metal N weighted meta-analysis presented in Panel 4 – note the Y axis is truncated

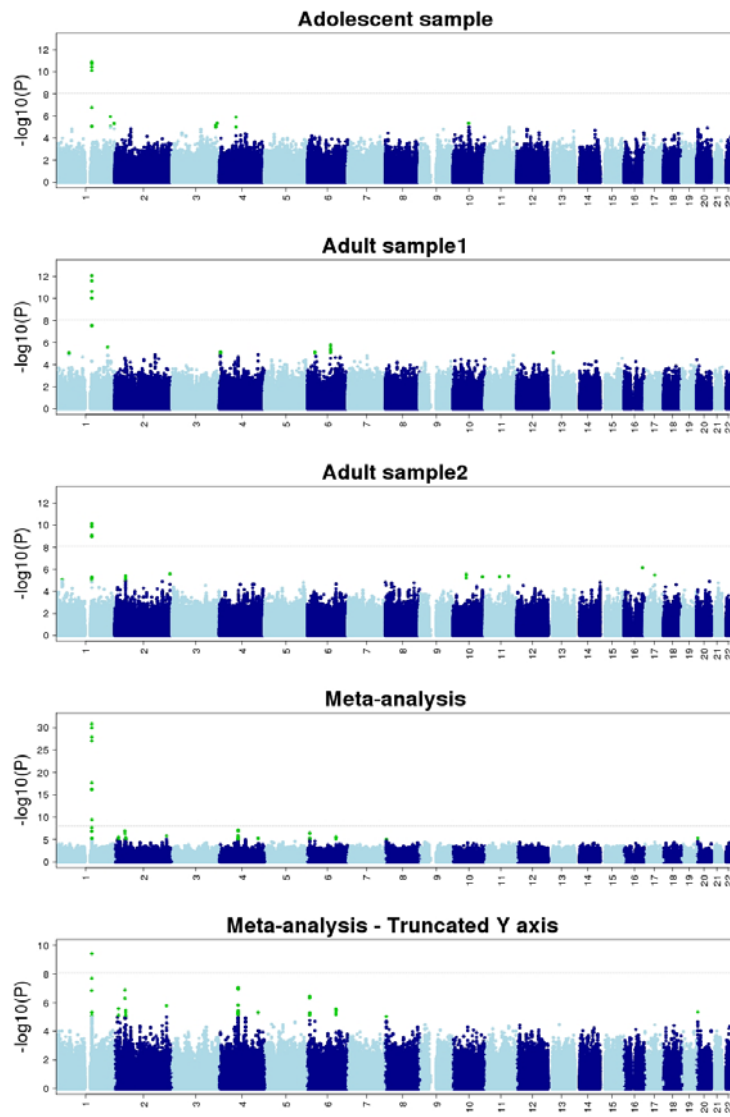

Figure S5: Panel 1, Results of the Meta-analysis for the three family samples; Panel 2, In addition, we carried out case-control analyses to facilitate further epistatic and conditional analyses. These analyses were conducted using the data from one individual from each family. The phenotypic data were re-coded as straight vs non-straight, and participants were preferentially selected for non-straight hair in order to maximise power. This resulted in a sample of 1289 wavy/curly cases (588 Male) and 1582 straight haired controls (994 Male). Results of the Plink logistic regression analyses of the case-control sub-sample correcting for age and sex; Panel 3, Results of the Plink logistic regression analyses of the case-control sub-sample correcting for age, sex and rs11803731 genotype; Panel 3, Results of the Plink epistasis analyses (in which evidence of interaction with rs11803731 is considered for each SNP in turn across the genome) of the case-control sub-sample

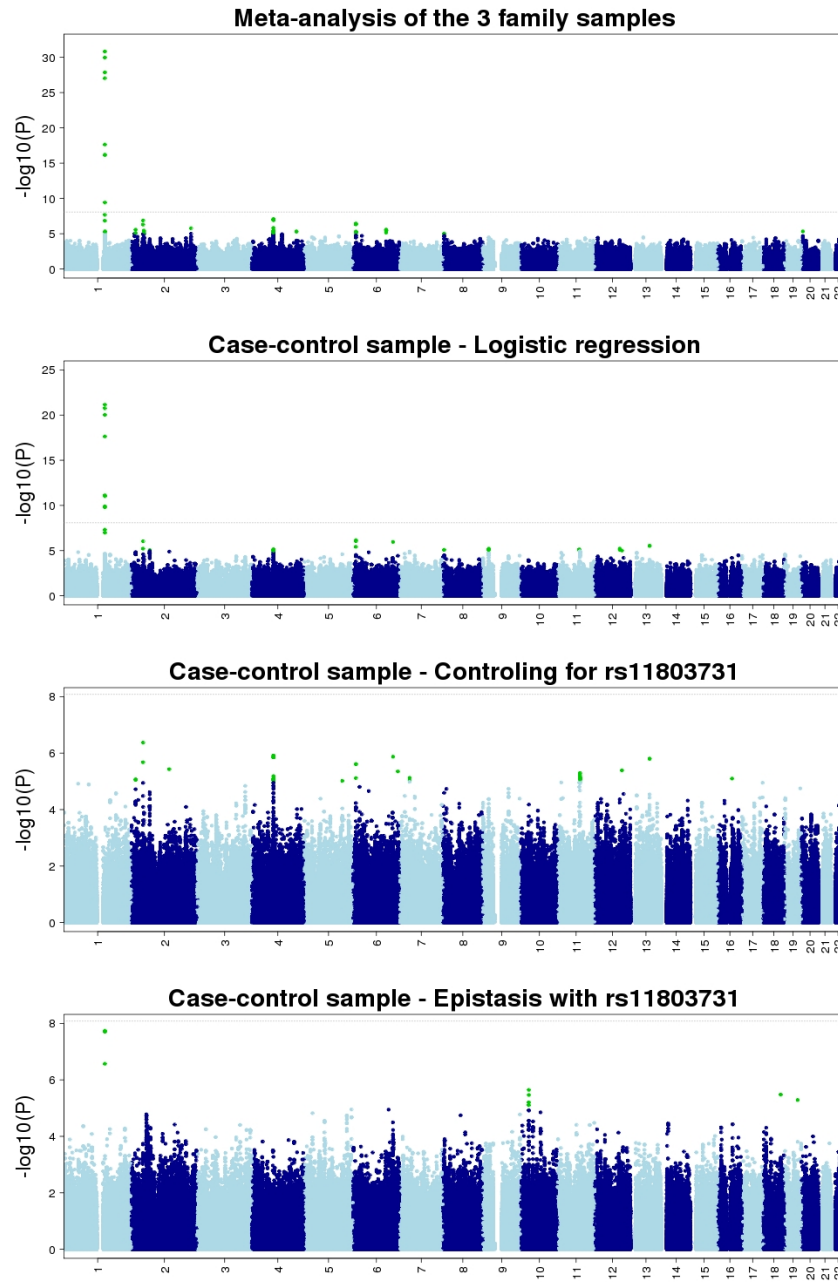

Figure S6: Panel 1, Results of the Plink logistic regression analyses of the case-control sub-sample in Males correcting for age; Panel 2, Results of the Plink logistic regression analyses of the case-control sub-sample in Females correcting for age; Panel 3, Results of the Plink heterogeneity of odds ratios analyses of the case-control sub-sample testing for differences in odds ratios between the sexes. As expected, given the magnitude of the association signal, there was no evidence of sex differences in the 1q21.3 region. The strongest evidence of heterogeneity was observed at rs10817168 ($P = 4.8 \times 10^{-7}$) on Chromosome 9 (113,114,526 bp).

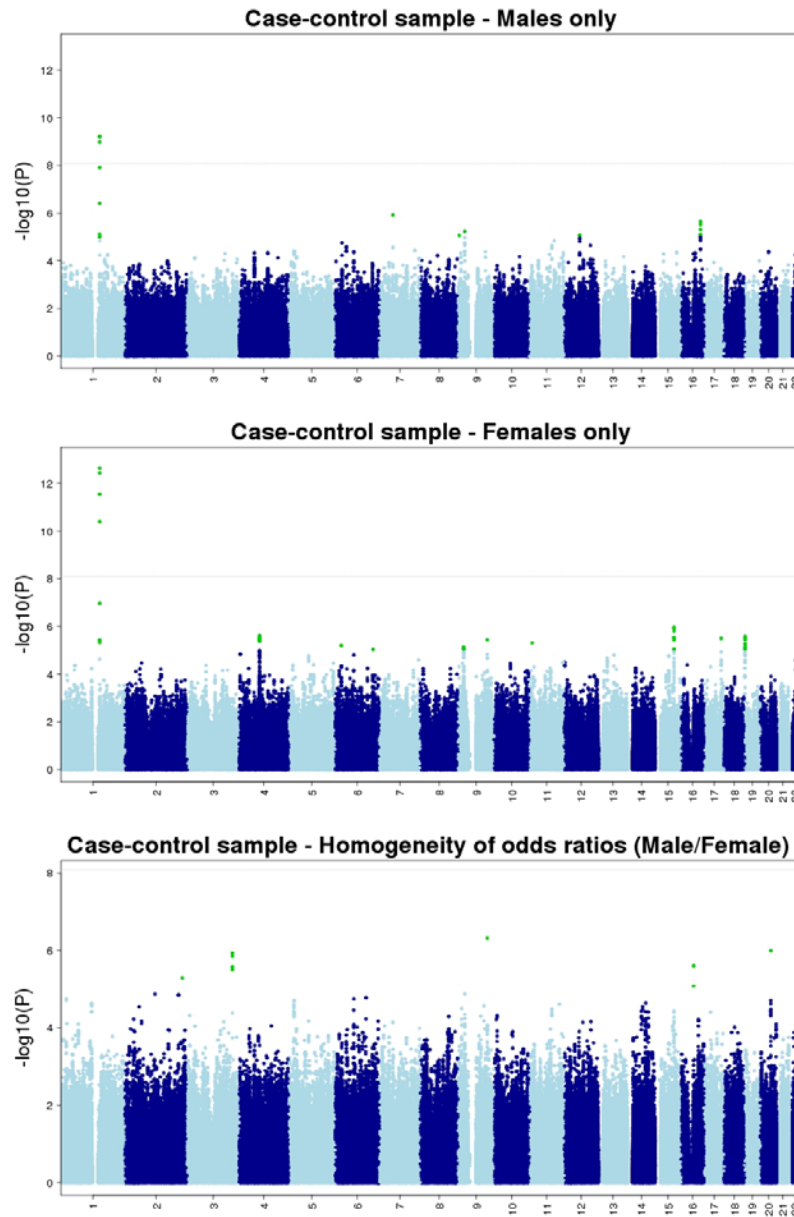

Figure S7: Extended Haplotype Homozygosity Patterns within the 1q21.3 Region in the HGDP Cohort

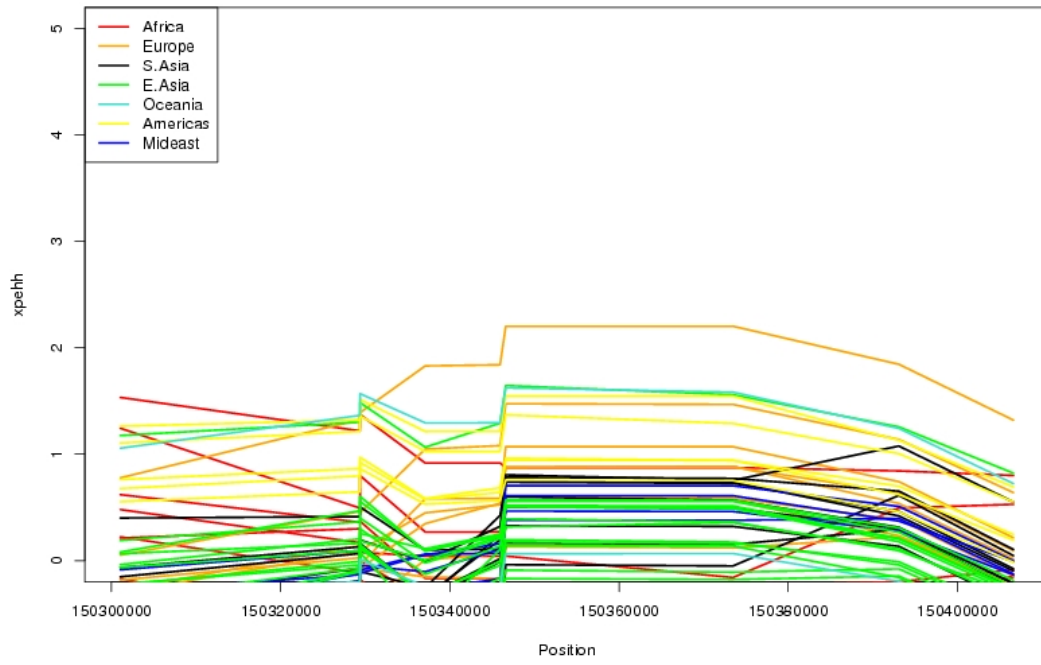
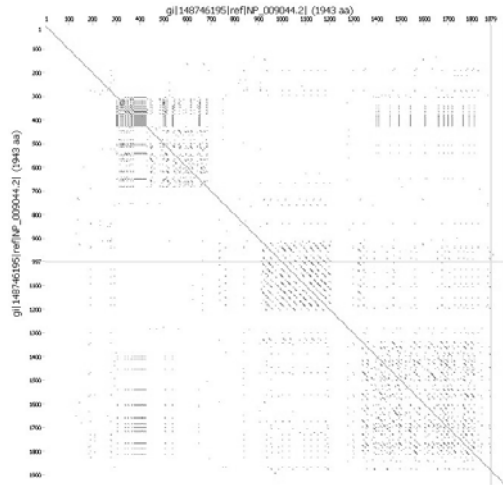
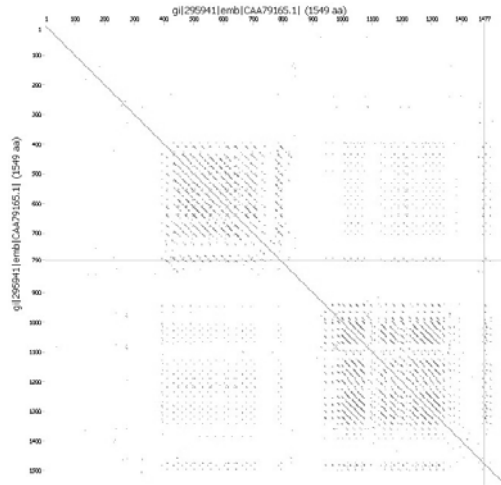

Figure S8. Dot plot comparisons of TCHH proteins illustrating regions containing repetitive amino acid (aa) motifs in a) Human (*Homo sapiens*; NP_009044.2), b) Sheep (*Ovis aries*; CAA79165.1), c) Rabbit (*Oryctolagus cuniculus*; CAA79165.1) and d) Mouse (*Mus musculus*; NP_001156570.1). Only species for which the aa sequences are known rather than predicted are shown. The position of the p.Leu790Met change caused by rs11803731, between the first and second repetitive aa regions in humans, is indicated by a dot on the human plot.

a)



b)



c)

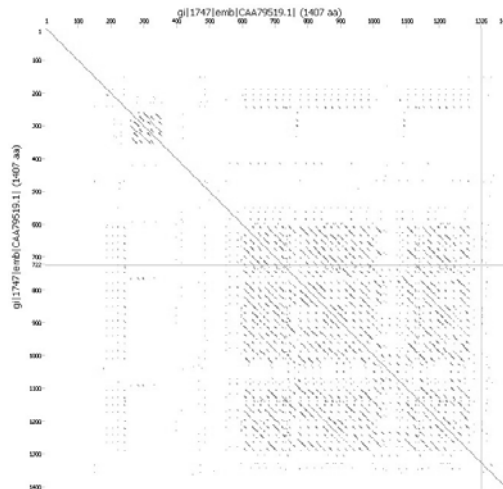

d)

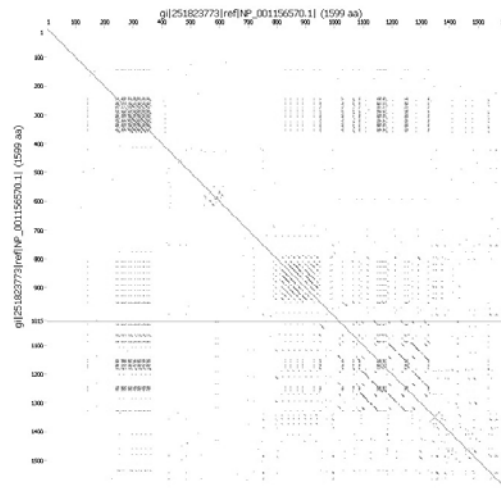

Figure S9: Minor Allele Frequency for the *EDAR* SNP rs3827760 Based on the Human Genome Diversity Project ⁵

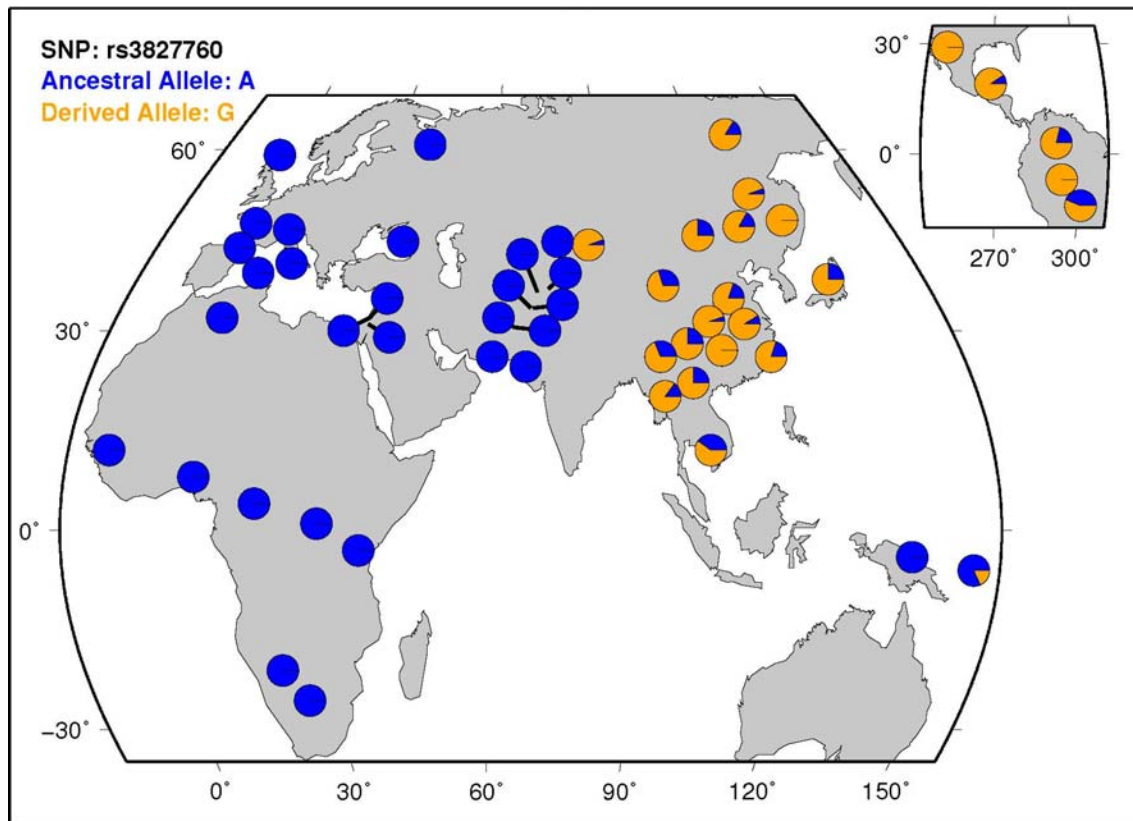

Table S1: Comparative Populations Used in the EIGENSOFT Principal Component Analysis

Abbreviation	Population	n	Source
ASW	African ancestry in Southwest USA	49	Hapmap3
CEU	Utah residents with Northern and Western European ancestry from the CEPH collection	112	Hapmap3
CHB	Han Chinese in Beijing, China	84	Hapmap3
CHD	Chinese in Metropolitan Denver, Colorado	85	Hapmap3
GIH	Gujarati Indians in Houston, Texas	88	Hapmap3
JPT	Japanese in Tokyo, Japan	86	Hapmap3
LWK	Luhya in Webuye, Kenya	90	Hapmap3
MEX	Mexican ancestry in Los Angeles, California	50	Hapmap3
MKK	Maasai in Kinyawa, Kenya	143	Hapmap3
TSI	Toscans in Italia	88	Hapmap3
YRI	Yoruba in Ibadan, Nigeria	113	Hapmap3
UK	United Kingdom	433	GenomeEUtwin
NET	Netherlands	284	GenomeEUtwin
DEN	Denmark	161	GenomeEUtwin
SWE	Sweden	302	GenomeEUtwin
FIN	Finland	149	GenomeEUtwin

In order to identify gross ancestry outliers we used Principal Component Analysis (PCA) of similarly genotyped data from 16 global populations sourced from Hapmap Phase 3 [HM3] (11 populations) and a previously published study of Northern European genetic diversity (GEUT - 5 populations)¹. Details of the comparative populations used are given in Table S5. PCA was conducted using the autosomal SNPs that were genotyped in common between all Australian cohorts, HM3 and GEUT populations with the further proviso that SNP missing rates were < 2.5% in all individual cohorts and populations. A total of 225,455 SNPs fulfilled these requirements.

Table S2: Summary of the 18 CNVs Detected in the TCHH Region

ID	Start B.P. (SNP)	Stop B.P. (SNP)	Length (No. SNP)	Copy Number	log Bayes Factor
1	150345938 (rs9050)	150349857 (rs2496257)	3919 (4)	1	1.68
2	150373477 (rs11588437)	150531734 (cnvi0009402)	158257 (40)	1	2.95
3	150102061 (rs6587626)	150248644 (rs2932574)	146583 (21)	1	3.34
4	150345938 (rs9050)	150373477 (rs11588437)	27539 (5)	1	1.23
5	150345938 (rs9050)	150373477 (rs11588437)	27539 (5)	1	6.35
6	150317309 (cnvi0009354)	150432502 (rs1552991)	115193 (24)	1	1.25
7	150345938 (rs9050)	150373477 (rs11588437)	27539 (5)	0	4.97
7	150406640 (rs1496036)	150432502 (rs1552991)	25862 (13)	3	2.19
8	150345938 (rs9050)	150373477 (rs11588437)	27539 (5)	1	0.88
9	150233369 (rs1038745)	150610517 (rs11204988)	377148 (71)	1	2.44
10	150345938 (rs9050)	150373477 (rs11588437)	27539 (5)	0	4.35
10	150406640 (rs1496036)	150432502 (rs1552991)	25862 (13)	3	-1.85
11	150317309 (cnvi0009354)	150373477 (rs11588437)	56168 (11)	1	6.02
11	150406640 (rs1496036)	150432502 (rs1552991)	25862 (13)	3	-0.04
12	150345938 (rs9050)	150349857 (rs2496257)	3919 (4)	1	3.4
13	150348488 (rs2496252)	150349857 (rs2496257)	1369 (2)	1	1.37
14	150317309 (cnvi0009354)	150349857 (rs2496257)	32548 (10)	1	5.98
15	150406640 (rs1496036)	150422946 (rs12079949)	16306 (6)	1	2.74
16*	150233369 (rs1038745)	150373477 (rs11588437)	140108 (22)	1	7.92
17*	150233369 (rs1038745)	150373477 (rs11588437)	140108 (22)	1	1.41

* Individuals 16 and 17 are siblings

CNV status of the TCHH region was investigated in the ADOL_deCODE sample using the program QuantiSNP³ on the Illumina 610K arrays. The default program settings were used with the addition of setting the maximum copy number to four and enabling the GC correction. In total, 18 individuals showed some evidence for copy number variation in the region flanked by SNPs rs1038745 and rs924088. Three samples contained two copy number variants, each with one copy number gain and one copy number loss. No further copy number gains were observed across all samples. However, this does not exclude copy number variants that are smaller than the detection capability of this array being important in the underlying biological mechanism.

Table S3: SNPs with a Combined p Value of Less Than $p < 1 \times 10^{-5}$ for the Meta-Analysis.

SNP	CHR	BP	Effect Allele	Non Effect Allele	P value	Closest gene	SNP Type
rs17646946	1	152062767	a	g	1.500e-31	TCHH	UPSTREAM NON SYNONYMOUS CODING
rs11803731	1	152083325	a	t	3.184e-31	TCHH	UPSTREAM NON SYNONYMOUS CODING
rs4845418	1	152136230	c	g	4.429e-29	AL135842.2	UPSTREAM
rs12130862	1	152027015	a	t	3.118e-28	AL591893.2	INTERGENIC WITHIN NON CODING GENE
rs12123975	1	152004804	a	g	1.143e-18	AL591893.3	WITHIN NON CODING GENE
rs2999547	1	152002663	a	c	3.43e-17	AL591893.3	WITHIN NON CODING GENE
rs3007671	1	151999347	t	g	3.456e-17	AL591893.3	WITHIN NON CODING GENE
rs1858483	1	152310086	t	c	2.632e-10	AL135842.2	WITHIN NON CODING GENE
rs10788819	1	151895093	t	c	1.556e-08	AL450992.4	INTERGENIC
rs1268789	4	79499717	t	c	6.58e-08	FRAS1	INTRONIC
rs375726	4	79500774	t	c	7.381e-08	FRAS1	INTRONIC
rs431907	4	79500052	a	g	7.401e-08	FRAS1	INTRONIC
rs447200	4	79499112	t	c	7.474e-08	FRAS1	INTRONIC
rs120233	4	79501372	a	g	7.618e-08	FRAS1	INTRONIC
rs22078	4	79501556	c	g	7.859e-08	FRAS1	INTRONIC
rs1385131	4	79501783	a	g	8.119e-08	FRAS1	INTRONIC
rs345545	4	79502667	t	g	8.228e-08	FRAS1	INTRONIC
rs345544	4	79502735	a	t	8.284e-08	FRAS1	INTRONIC
rs529184	4	79502427	t	c	8.391e-08	FRAS1	INTRONIC
rs345546	4	79502619	a	g	8.452e-08	FRAS1	INTRONIC
rs6732426	2	43441008	t	c	9.954e-08	THADA	INTRONIC
rs11204897	1	151809066	a	g	1.092e-07	AL589765.4	UPSTREAM
rs3901678	2	43440955	t	g	3.971e-07	THADA	INTRONIC
rs13103319	4	79469734	a	t	1.155e-06	FRAS1	INTRONIC
rs7349332	2	219464627	t	c	1.363e-06	WNT10A	INTRONIC
rs7586898	2	15879050	c	g	2.152e-06	AC113608.1	INTERGENIC
rs12623288	2	46488149	a	g	2.837e-06	AC016912.4	INTERGENIC
rs1027444	4	79612898	a	g	3.128e-06	FRAS1	INTRONIC
rs2008485	4	79495612	a	g	3.144e-06	FRAS1	INTRONIC
rs949507	4	79613110	a	g	3.173e-06	FRAS1	INTRONIC
rs454598	4	79480769	a	c	3.201e-06	FRAS1	INTRONIC
rs393285	4	79499216	t	g	3.383e-06	FRAS1	INTRONIC
rs261360	20	4985774	a	g	3.439e-06	AL121890.2	INTERGENIC
rs2627654	4	79597833	a	g	3.44e-06	FRAS1	INTRONIC
rs1484342	4	79598449	t	c	3.505e-06	FRAS1	INTRONIC
rs2645149	4	79597562	a	g	3.519e-06	FRAS1	INTRONIC
rs2627651	4	79601917	a	g	3.562e-06	FRAS1	INTRONIC
rs6840361	4	163957571	c	g	3.676e-06	NAF1	INTERGENIC
rs2627656	4	79596913	t	c	3.697e-06	FRAS1	INTRONIC
rs10027421	4	163951240	a	t	3.775e-06	NAF1	INTERGENIC

(Table S3 continued)

rs1496581	4	79596215	a	c	3.813e-06	FRAS1	INTRONIC
rs908922	1	150721215	a	g	3.845e-06	LCE5A	INTERGENIC
rs1496582	4	79596208	t	c	3.881e-06	FRAS1	INTRONIC
rs7577700	2	46464109	t	g	3.926e-06	EPAS1	INTRONIC
rs1496583	4	79596020	t	c	3.975e-06	FRAS1	INTRONIC
rs3124314	1	150304139	t	c	4.01e-06	AL591893.2	INTERGENIC
rs2627650	4	79595931	t	c	4.084e-06	FRAS1	INTRONIC
rs2627653	4	79605300	a	g	4.144e-06	FRAS1	INTRONIC
rs345542	4	79507262	a	c	4.224e-06	FRAS1	INTRONIC
rs1496584	4	79594614	a	g	4.235e-06	FRAS1	INTRONIC
rs7674053	4	79636887	a	g	4.366e-06	FRAS1	INTRONIC
rs1484331	4	79574213	a	g	4.374e-06	FRAS1	INTRONIC
rs2645145	4	79594424	a	g	4.376e-06	FRAS1	INTRONIC
rs2645144	4	79594396	a	g	4.456e-06	FRAS1	INTRONIC
rs2645143	4	79594061	a	g	4.656e-06	FRAS1	INTRONIC
rs6816851	4	79576806	a	g	4.876e-06	FRAS1	INTRONIC
rs2903470	4	79578033	c	g	4.914e-06	FRAS1	INTRONIC
rs7699000	4	79582560	c	g	5.097e-06	FRAS1	INTRONIC SPlice_SITE; SYNONYMOUS CODING
rs753752	4	79591954	t	c	5.098e-06	FRAS1	INTRONIC
rs11730871	4	79587840	t	c	5.143e-06	FRAS1	INTRONIC
rs4975067	4	79588791	a	c	5.149e-06	FRAS1	INTRONIC
rs2867068	4	79584546	a	g	5.158e-06	FRAS1	INTRONIC
rs959539	4	79591717	t	g	5.168e-06	FRAS1	INTRONIC
rs2867070	4	79587698	t	g	5.17e-06	FRAS1	INTRONIC
rs10026662	4	79591880	a	c	5.194e-06	FRAS1	INTRONIC
rs17035085	2	46458791	a	g	5.959e-06	EPAS1	INTRONIC
rs17035106	2	46486982	a	g	6.383e-06	AC016912.4	INTERGENIC
rs2380694	2	15876254	t	c	6.417e-06	AC113608.1	INTERGENIC
rs8017455	14	80645207	t	c	6.479e-06	TSHR	INTRONIC
rs1496036	1	150406640	a	g	6.667e-06	AL135842.2	INTERGENIC
rs7143914	14	80638353	a	g	7.284e-06	TSHR	INTRONIC
rs1454292	8	4913873	t	c	7.733e-06	AC019176.2	INTERGENIC
rs6669608	1	150741857	a	g	8.224e-06	LCE5A	INTERGENIC WITHIN NON CODING GENE
rs4674347	2	219467323	c	g	8.481e-06	WNT10A	INTRONIC WITHIN NON CODING GENE
rs13429458	2	43492342	a	c	8.506e-06	THADA	INTRONIC WITHIN NON CODING GENE
rs17605562	2	11954630	t	c	8.782e-06	AC096559.2	INTRONIC
rs10033307	4	79523250	t	g	9.084e-06	FRAS1	INTRONIC
rs2035511	4	79571484	a	g	9.091e-06	FRAS1	INTRONIC
rs17316633	4	111045083	a	g	9.421e-06	EGF	INTERGENIC
rs2100484	4	79503300	t	c	9.423e-06	FRAS1	INTRONIC
rs6833805	4	79503452	t	g	9.434e-06	FRAS1	INTRONIC
rs2054722	4	79569139	t	c	9.437e-06	FRAS1	INTRONIC

(Table S3 continued)

rs6835769	4	79503718	t	c	9.442e-06	FRAS1	NON SYNONYMOUS CODING
rs17035091	2	46463913	c	g	9.527e-06	EPAS1	INTRONIC
rs2298989	4	111111122	t	c	9.697e-06	EGF	INTRONIC

Table S4: SNPs located within the 170 candidate genes published by Fujimoto et al ⁴ with a combined p value of less than .001 for the meta-analysis. (a 20kb border was included in the start and end locations of each gene). Note the EDAR (rs3827760) and FGFR2 (rs4752566) SNPs associated with hair morphology in Asian populations were not significant in the current sample.

GENE	SNP	CHR	BP	Effect Allele	Non Effect Allele	P
COL22A1	rs10101430	8	139893239	a	g	0.009057
COL22A1	rs7838450	8	139892385	t	c	0.005354
COL22A1	rs10107709	8	139890134	t	g	0.005319
COL22A1	rs7016754	8	139881491	t	c	0.002641
COL22A1	rs7836628	8	139866982	t	c	0.00155
COL22A1	rs6998177	8	139881401	a	g	0.003105
COL22A1	rs4281141	8	139876143	c	g	0.00158
COL22A1	rs11779129	8	139888085	a	c	0.004281
COL22A1	rs10086199	8	139889816	a	g	0.005274
COL22A1	rs7837787	8	139875897	a	g	0.002479
COL22A1	rs12547982	8	139885233	t	g	0.00172
COL22A1	rs4736259	8	139953356	c	g	0.004809
COL22A1	rs6577948	8	139867381	a	g	0.001535
COL22A1	rs11992887	8	139878293	t	g	0.00463
COL22A1	rs11786131	8	139890504	a	t	0.004576
COL22A1	rs16893541	8	139890024	c	g	0.004519
COL22A1	rs7838300	8	139892274	t	c	0.005376
COL22A1	rs6988229	8	139953691	t	c	0.003274
COL22A1	rs4991003	8	139888849	a	c	0.00446
COL22A1	rs1879051	8	139891665	a	g	0.005411
COL22A1	rs11166845	8	139880292	t	c	0.001664
COL22A1	rs10090299	8	139890241	t	c	0.005328
COL22A1	rs12544238	8	139872634	a	t	0.002459
EDAR	rs6542787	2	108922797	a	g	0.008503
EDAR	rs11690981	2	108982543	a	g	0.003037
EDAR	rs13427222	2	108919310	t	c	0.006958
EDAR	rs7598206	2	108922850	a	g	0.008206
EDAR	rs10865026	2	108911488	a	g	0.006856
EDAR	rs5021634	2	108948789	a	g	0.002522
EDAR	rs899259	2	108913480	t	c	0.006877
EDAR	rs6542785	2	108922506	a	g	0.003112
EDAR	rs6761501	2	108916524	t	c	0.006936
EDAR	rs6542786	2	108922517	c	g	0.003127
EGFR	rs1107617	7	55247762	a	c	0.009309
FGF5	rs12054583	4	81400412	a	g	0.000144
FGF5	rs7681907	4	81424892	a	g	0.003374
FGF5	rs6826137	4	81437528	t	c	0.006462
FGF5	rs6827834	4	81419669	t	c	0.002653
FGF5	rs16998073	4	81403365	a	t	0.003415
FGF5	rs4690116	4	81425401	a	t	0.002614

(Table S4 continued)

GENE	SNP	CHR	BP	Effect Allele	Non Effect Allele	P
FGF5	rs11099098	4	81388936	t	g	0.003884
FGF5	rs982804	4	81426063	t	c	0.002612
FGF5	rs1458046	4	81418990	a	g	0.002656
FGF5	rs3796606	4	81413114	a	g	0.002722
FGF5	rs1379707	4	81399403	t	c	0.000146
GPC5	rs9589238	13	90899354	a	c	0.005625
GPC5	rs9583922	13	90870599	a	t	0.004983
GPC5	rs9583924	13	90872601	c	g	0.004969
GPC5	rs1333674	13	92002609	a	g	0.002326
GPC5	rs9301729	13	90893934	t	g	0.005012
GPC5	rs9989098	13	90891718	a	c	0.005391
GPC5	rs7324710	13	90883326	a	g	0.004839
GPC5	rs9589237	13	90899291	t	g	0.005539
GPC5	rs9583927	13	90881551	t	c	0.00497
GPC5	rs13378852	13	90882639	t	c	0.005013
GPC5	rs9589230	13	90883171	c	g	0.005014
KRTAP10	rs9978932	21	44948974	a	g	0.001831
KRTAP10	rs9981523	21	44941147	t	c	0.002583
KRTAP12	rs9981523	21	44941147	t	c	0.002583
LHCGR	rs11125179	2	48769375	a	g	0.000462
LHCGR	rs1949778	2	48778325	a	t	0.001862
LHCGR	rs1464729	2	48759460	t	c	0.002966
LHCGR	rs3792246	2	48752654	a	g	0.002492
LHCGR	rs1554614	2	48776569	t	c	0.001557
LHCGR	rs2293275	2	48774879	t	c	0.004115
LHCGR	rs1524151	2	48759553	a	c	0.002341
LHCGR	rs6713319	2	48757771	a	g	0.001398
LHCGR	rs1404056	2	48777817	t	g	0.004387
LHCGR	rs17326209	2	48761142	a	g	0.001753
LHCGR	rs2349101	2	48776207	a	g	0.00202
LHCGR	rs17326251	2	48770326	a	g	0.000474
MREG	rs13030243	2	216515472	t	c	0.002348
MREG	rs6435927	2	216516397	a	c	0.002304
MREG	rs6744723	2	216524663	t	c	0.007324
MREG	rs6706891	2	216525908	t	c	0.000479
MREG	rs1560233	2	216521215	a	g	0.000952
MREG	rs8911	2	216515971	a	g	0.002325
MREG	rs12995228	2	216508617	t	g	0.002044
TCHH	rs2935208	1	150344483	c	g	0.000298
TCHH	rs2496253	1	150348545	c	g	0.000288
TCHH	rs1496041	1	150355229	t	c	1.77E-05

(Table S4 continued)

GENE	SNP	CHR	BP	Effect Allele	Non Effect Allele	P
TCHH	rs11204925	1	150339744	a	g	0.001965
TCHH	rs1131473	1	150346447	c	g	1.86E-05
TCHH	rs17646946	1	150329391	a	g	1.50E-31
TCHH	rs1131471	1	150346613	t	g	0.000288
TCHH	rs11803731	1	150349949	a	t	3.18E-31
TGFA	rs2190649	2	70649984	t	c	0.006138
TGFA	rs2215021	2	70649765	a	g	0.006067
TGFA	rs1523303	2	70642406	t	c	0.005959
WNT10A	rs4674348	2	219478222	a	t	0.000231
WNT10A	rs4574113	2	219470906	a	g	0.00028
WNT10A	rs7571111	2	219477200	t	c	0.001767
WNT10A	rs7349332	2	219464627	t	c	1.36E-06
WNT10A	rs2385199	2	219458990	a	g	2.28E-05
WNT10A	rs4674347	2	219467323	c	g	8.48E-06
WNT10A	rs6723140	2	219482944	t	c	0.001801
WNT10A	rs6754599	2	219440386	c	g	1.05E-05
WNT10A	rs10193725	2	219434742	t	c	0.00033
WNT10A	rs10177996	2	219454805	t	c	0.002906
WNT10A	rs3806557	2	219452118	a	g	2.46E-05
WNT10A	rs6747776	2	219433562	c	g	0.001689
WNT10A	rs6723251	2	219483053	t	c	5.07E-05

Supplemental References

1. McEvoy, B.P., Montgomery, G.W., McRae, A.F., Ripatti, S., Perola, M., Spector, T.D., Cherkas, L., Ahmadi, K.R., Boomsma, D., Willemsen, G., et al. (2009). Geographical structure and differential natural selection among North European populations. *Genome Res* 19, 804-814.
2. Price, A.L., Patterson, N.J., Plenge, R.M., Weinblatt, M.E., Shadick, N.A., and Reich, D. (2006). Principal components analysis corrects for stratification in genome-wide association studies. *Nat Genet* 38, 904-909.
3. Colella, S., Yau, C., Taylor, J., Mirza, G., Butler, H., Clouston, P., Bassett, A., Seller, A., Holmes, C., and Ragoussis, J. (2007). QuantiSNP: an Objective Bayes Hidden-Markov Model to detect and accurately map copy number variation using SNP genotyping data. *Nucleic Acids Res* 35, 2013-2025.
4. Fujimoto, A., Kimura, R., Ohashi, J., Omi, K., Yuliwulandari, R., Batubara, L., Mustofa, M.S., Samakkarn, U., Settheetham-Ishida, W., Ishida, T., et al. (2008). A scan for genetic determinants of human hair morphology: EDAR is associated with Asian hair thickness. *Hum Mol Genet* 17, 835-843.
5. Li, J.Z., Absher, D.M., Tang, H., Southwick, A.M., Casto, A.M., Ramachandran, S., Cann, H.M., Barsh, G.S., Feldman, M., Cavalli-Sforza, L.L., et al. (2008). Worldwide human relationships inferred from genome-wide patterns of variation. *Science* 319, 1100-1104.