

A**B****C**

AMP-PNP

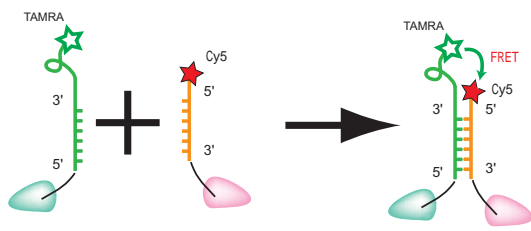

ATP

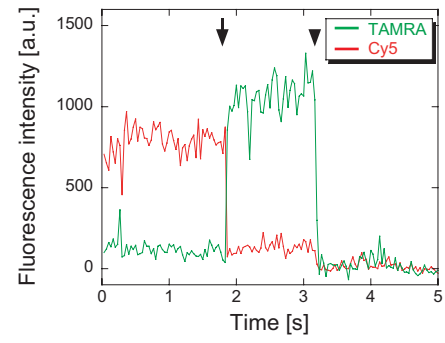
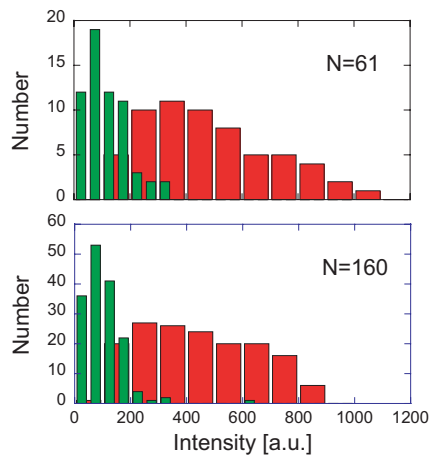
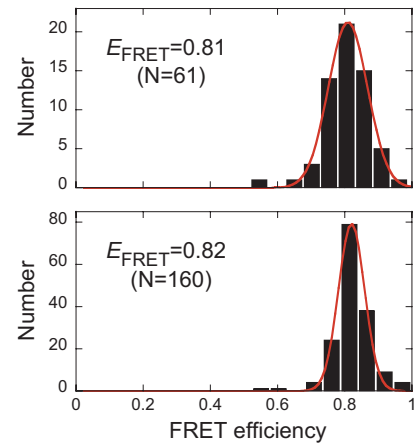

A

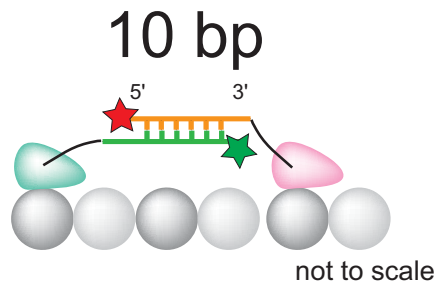

B

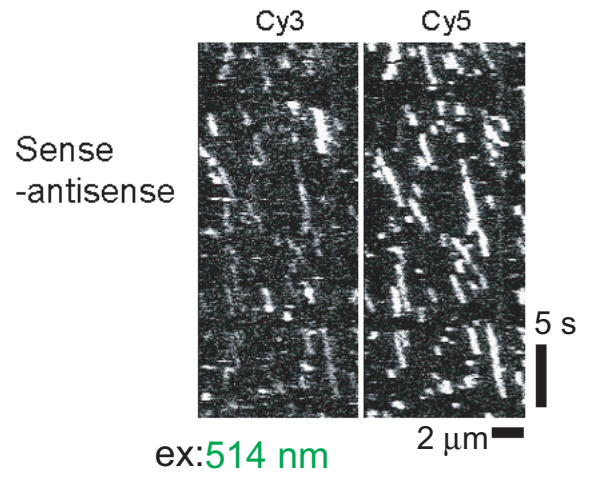

C

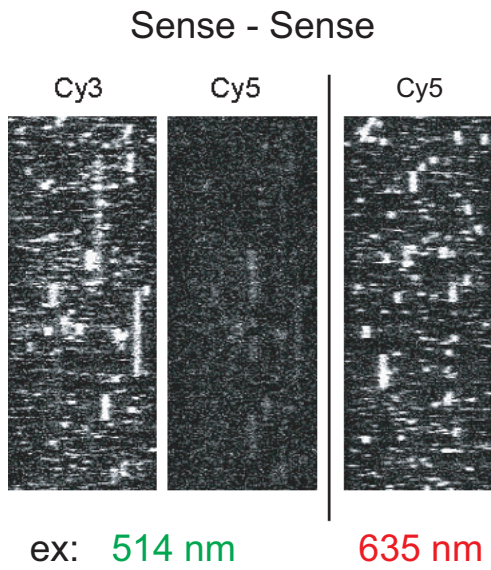

D

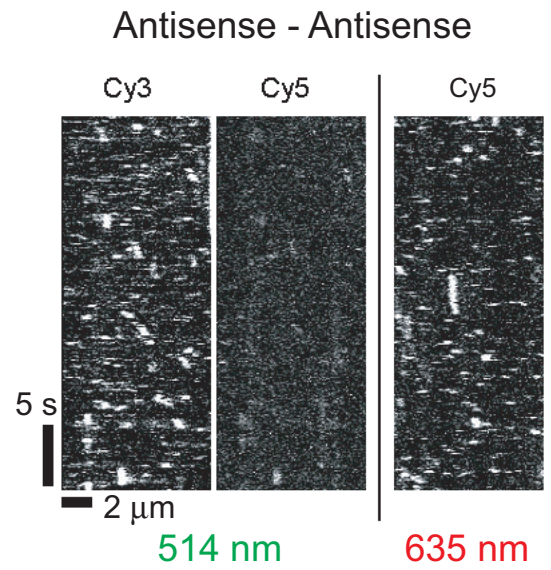

A

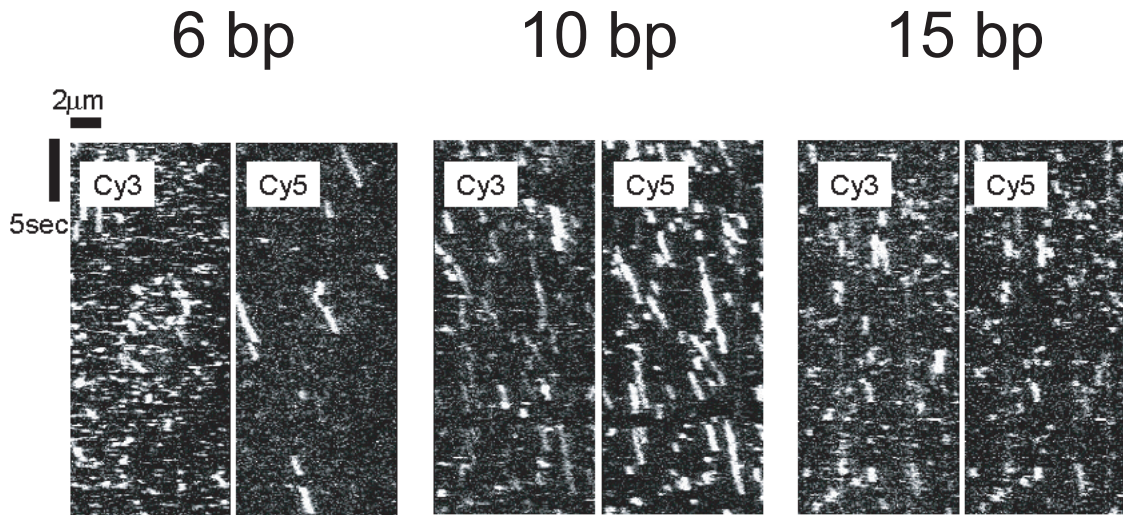

B

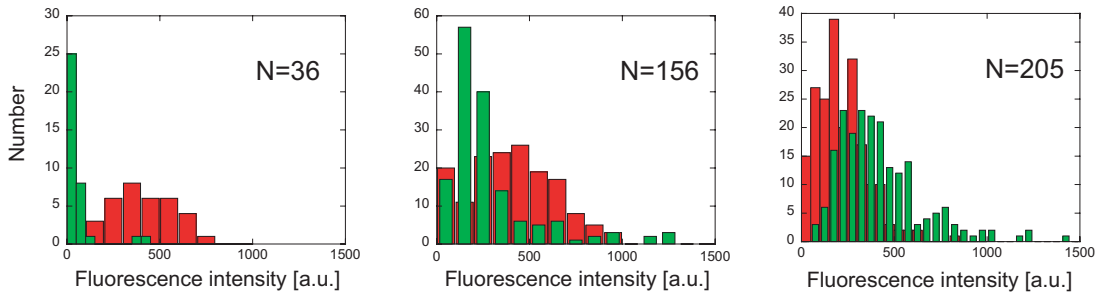

C

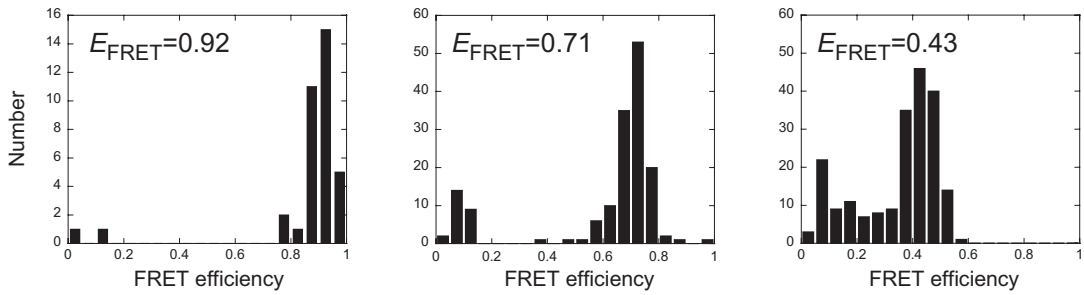

D

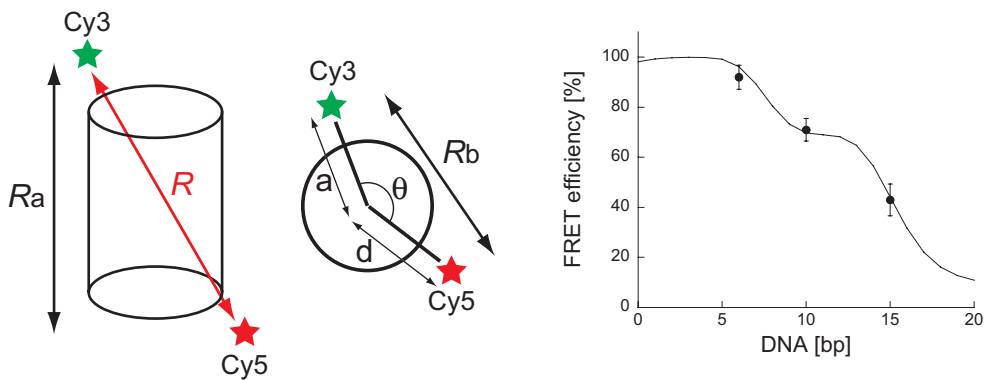

A

333

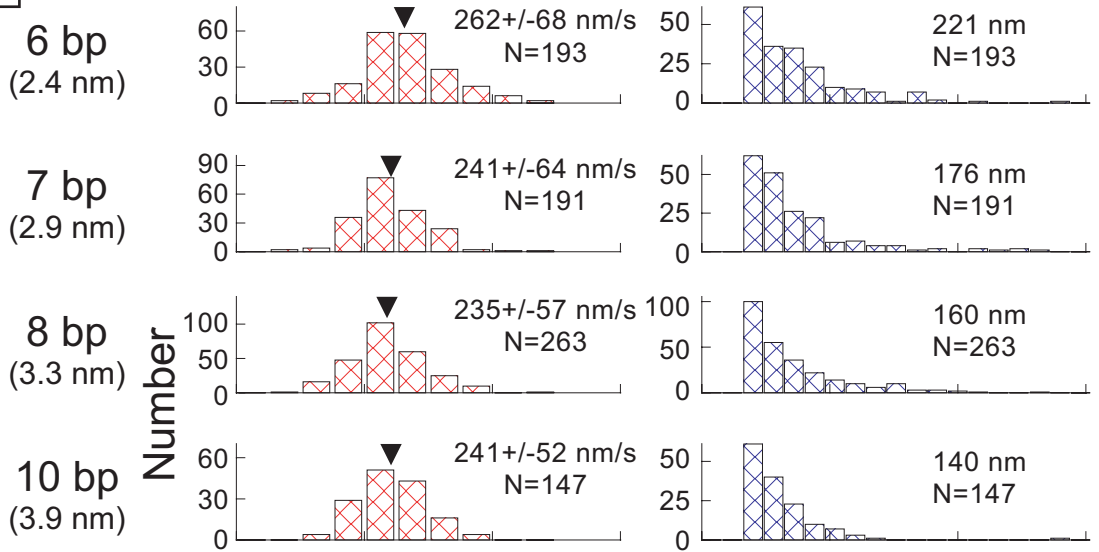

328

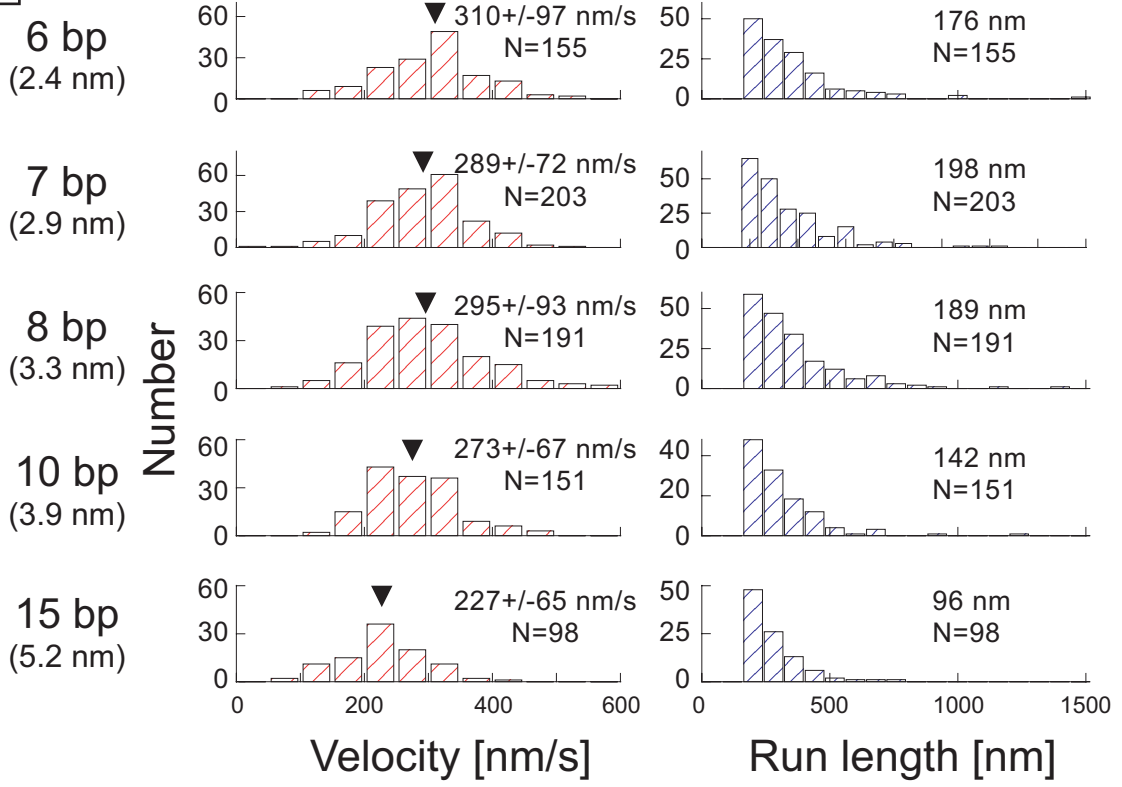

B

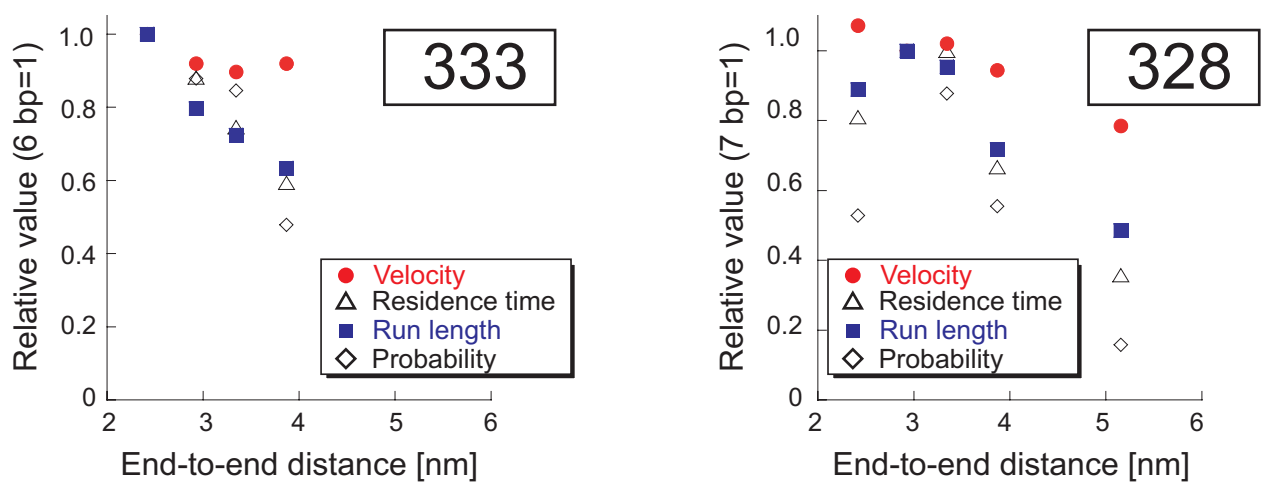

A

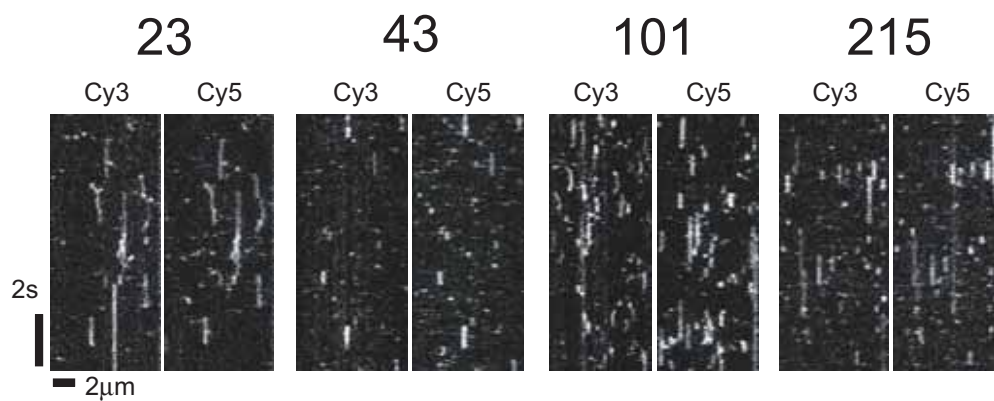

B

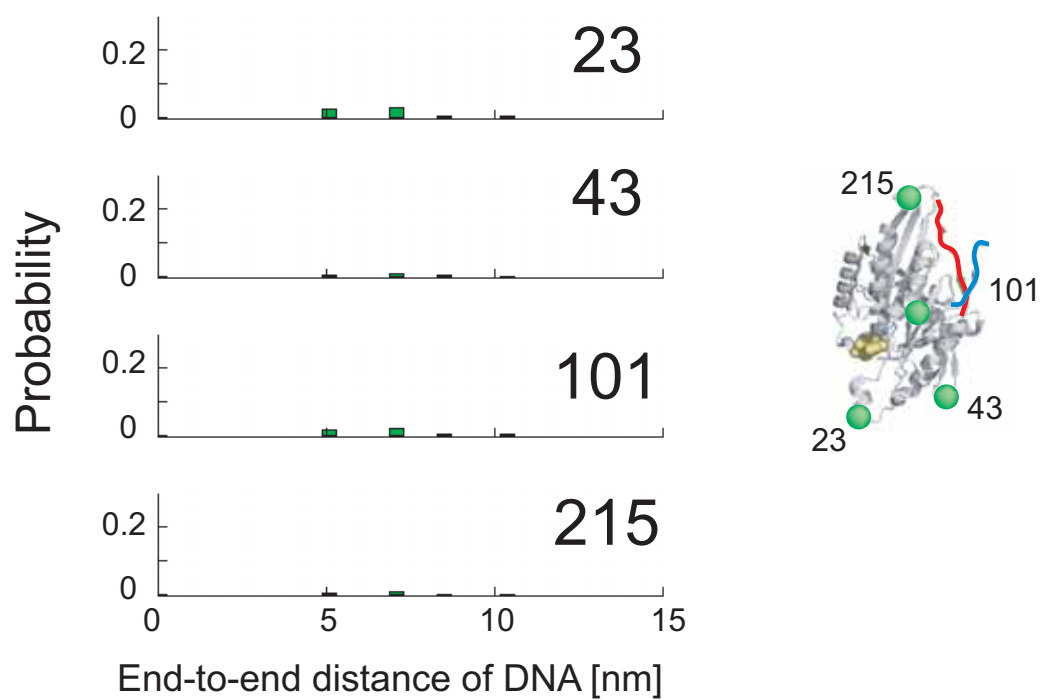

A

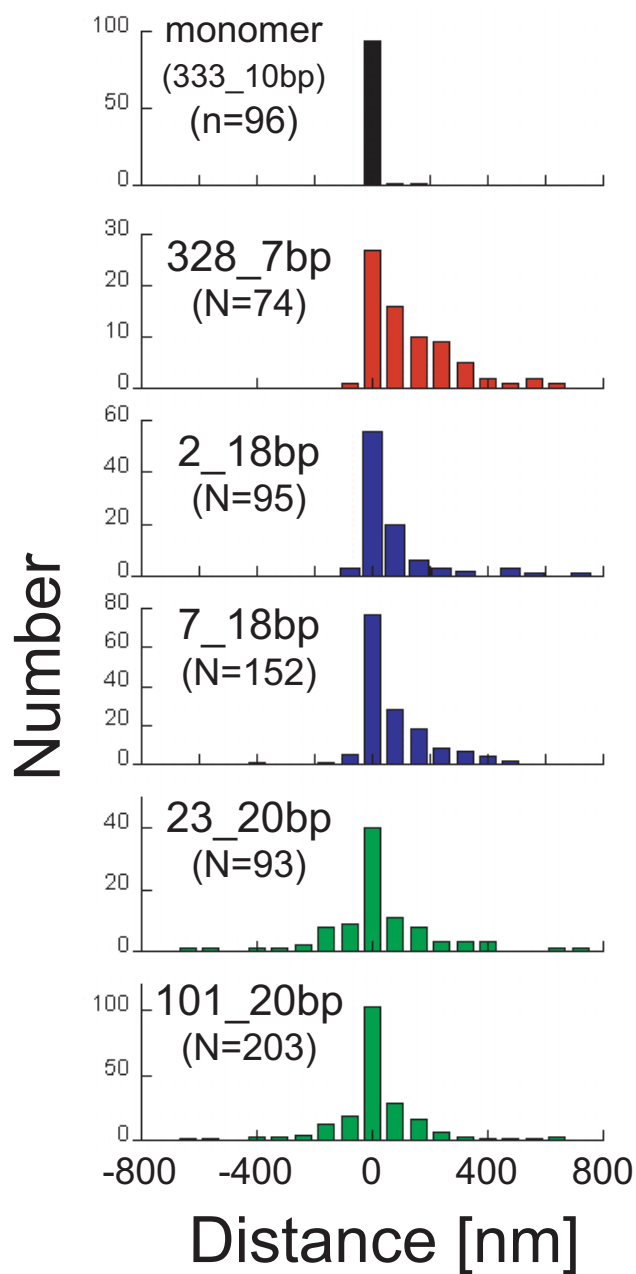

B

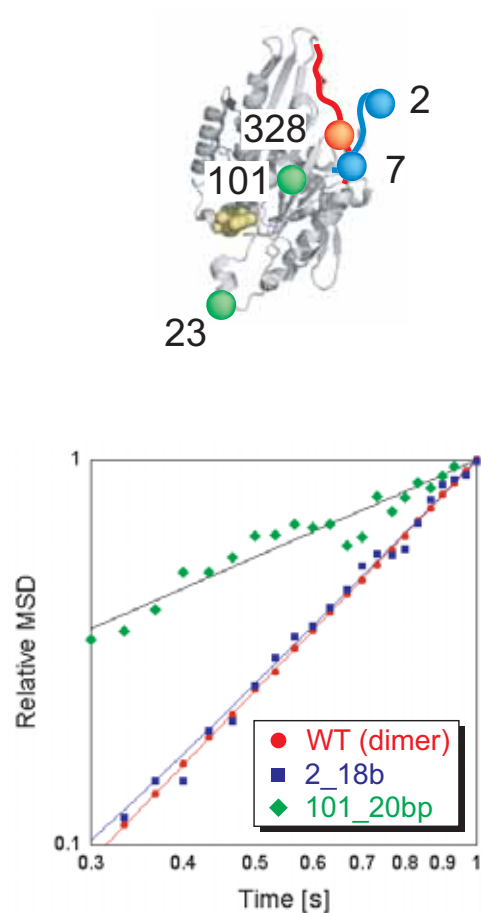

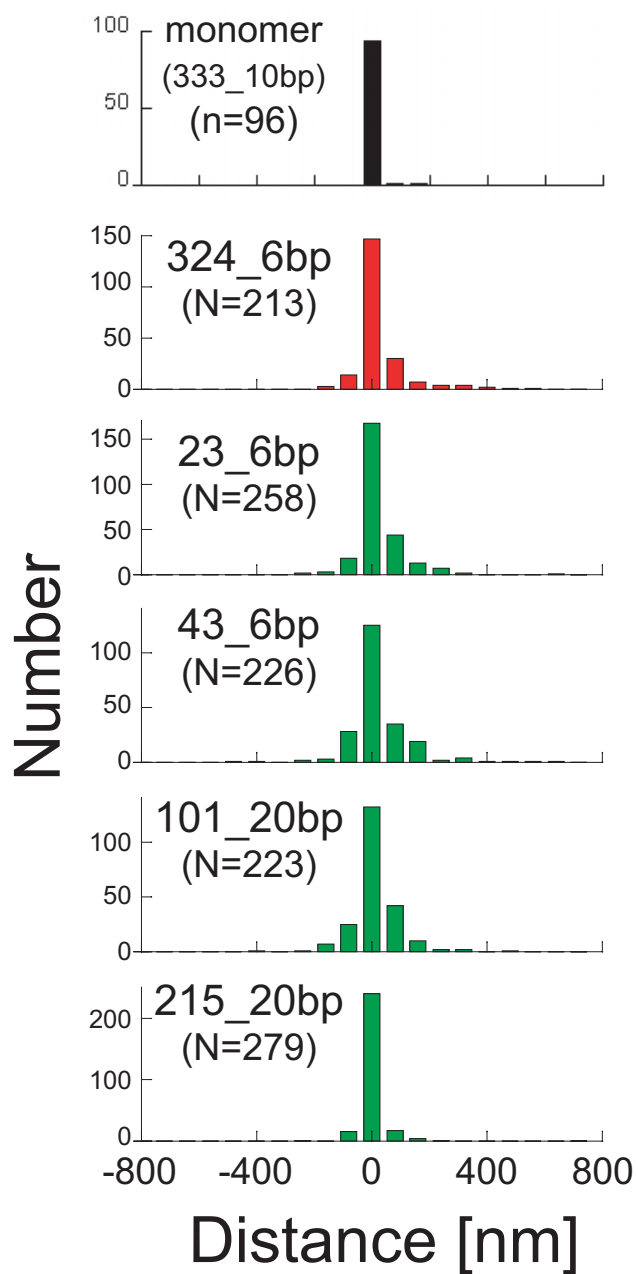
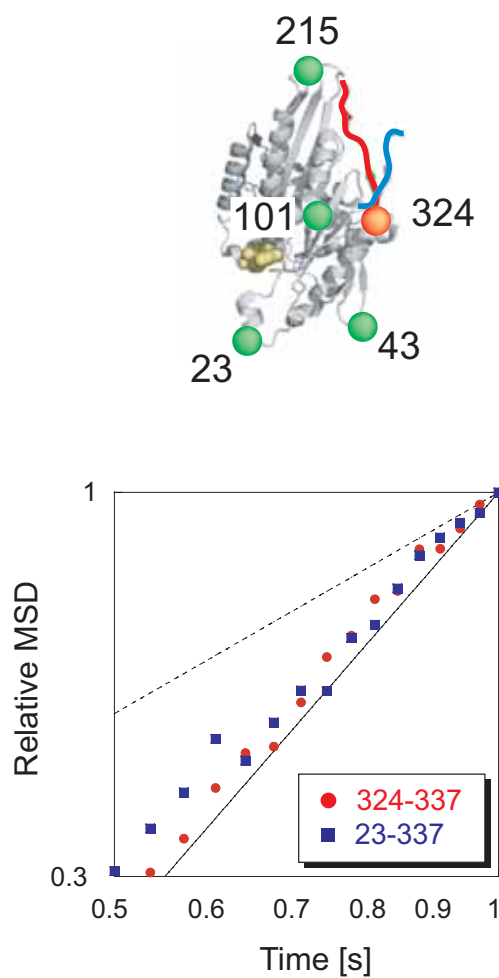
A**B**

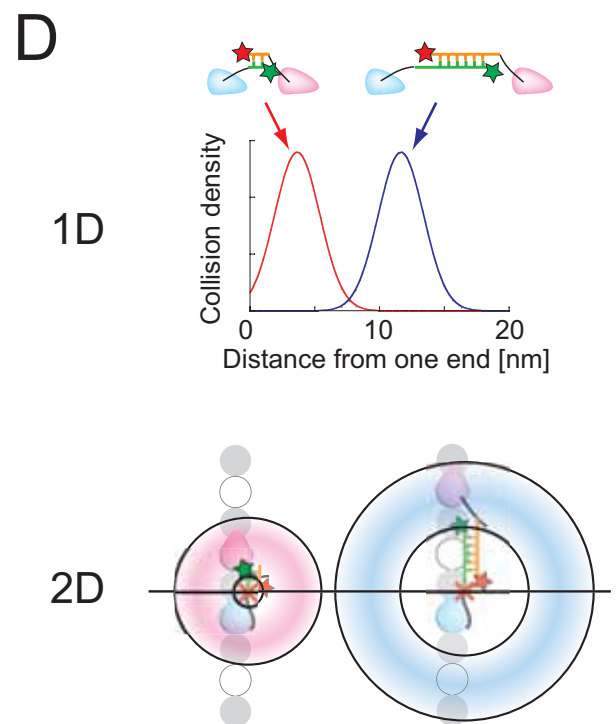
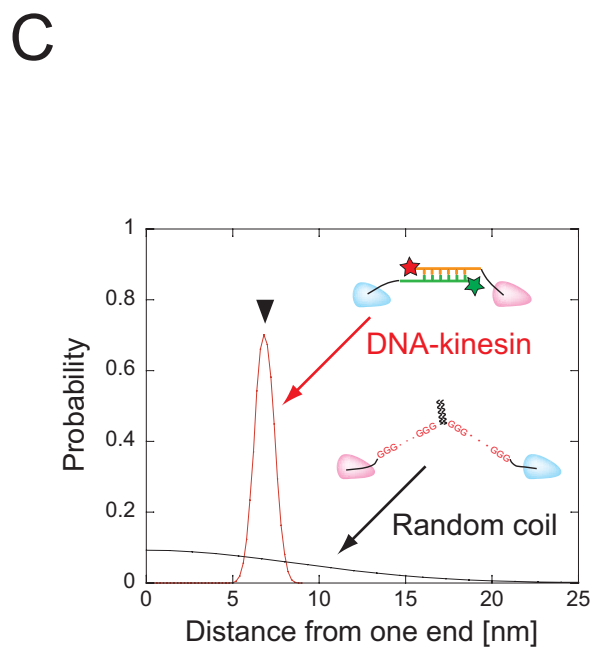
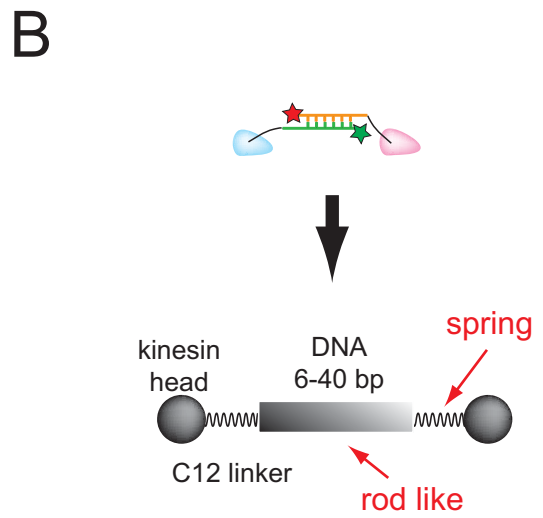
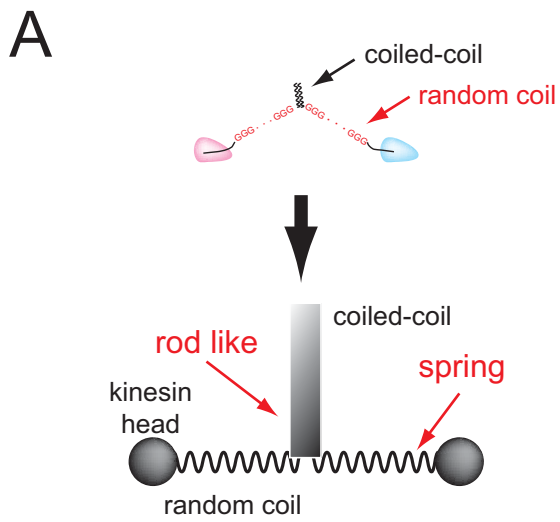

A

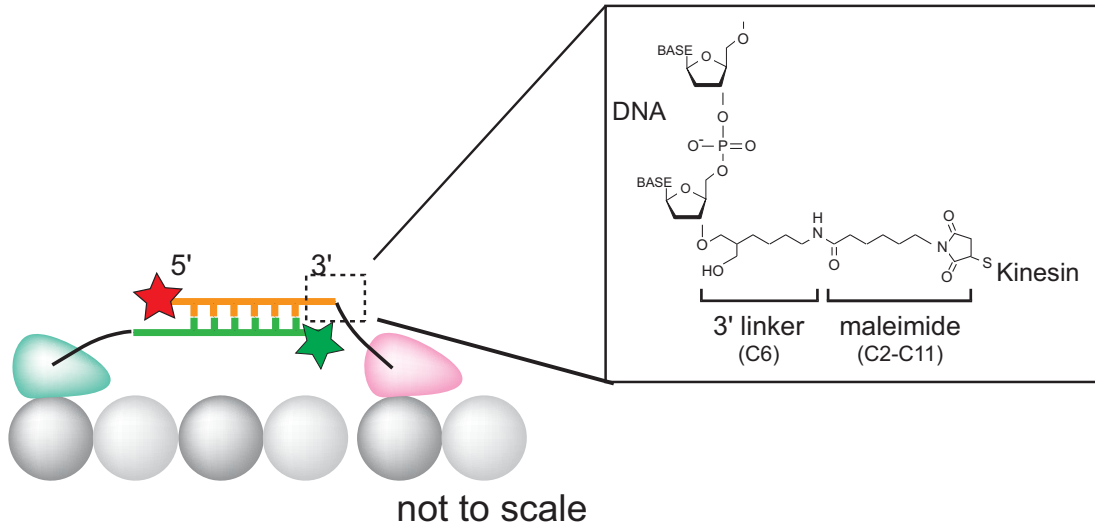

B

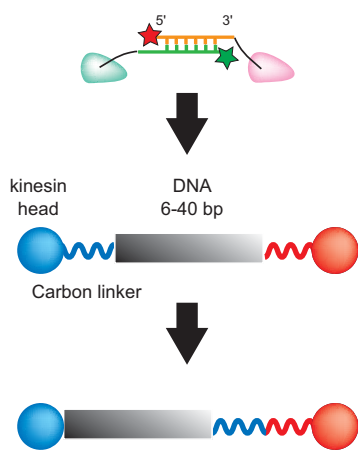

C

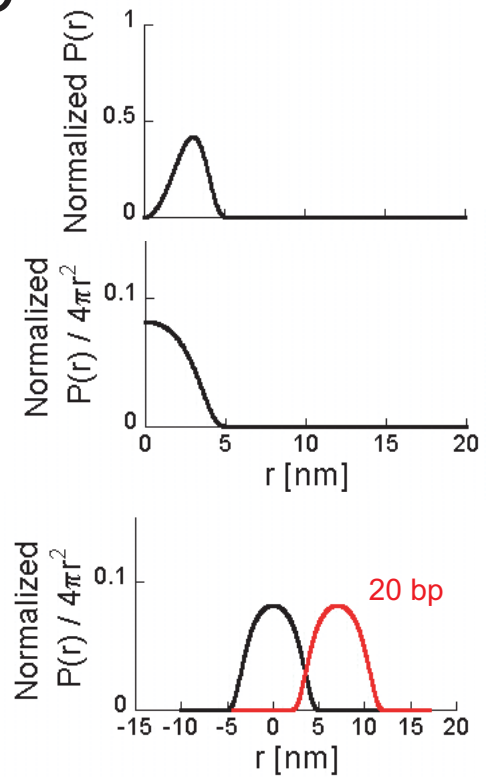

A

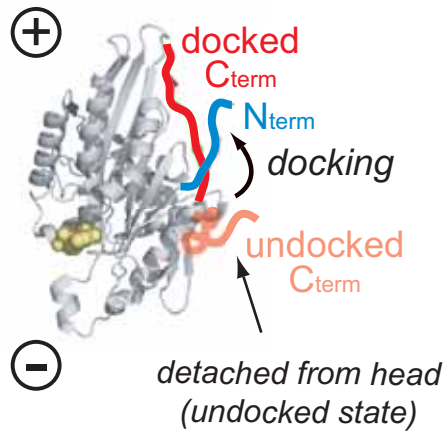

B

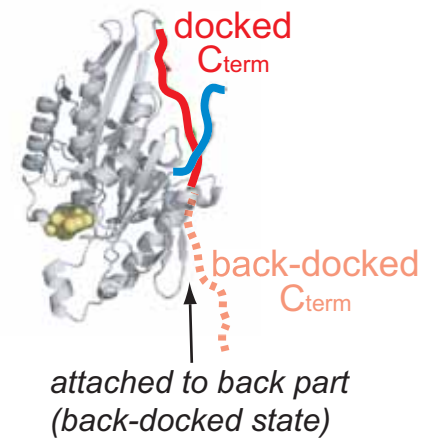

C

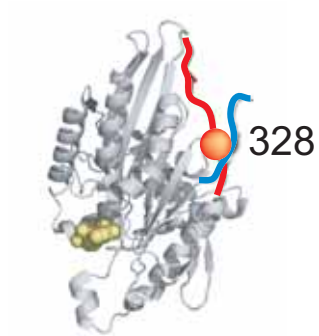

D

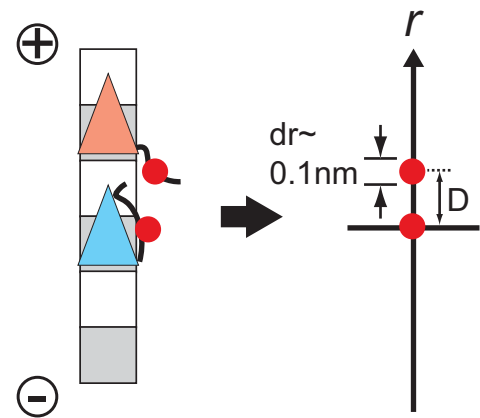

E

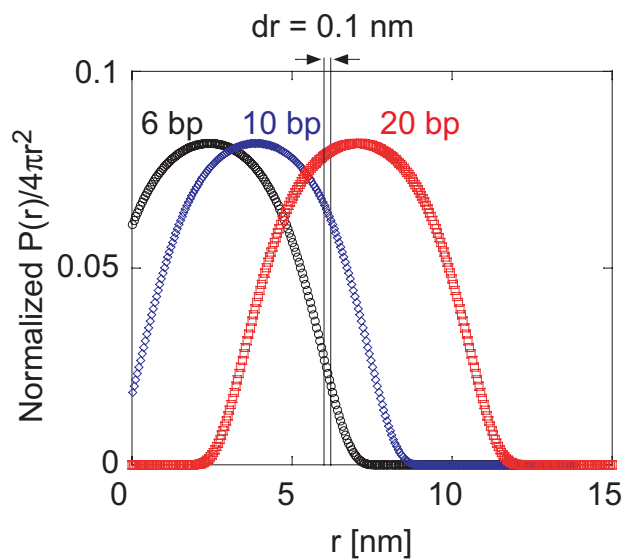

F

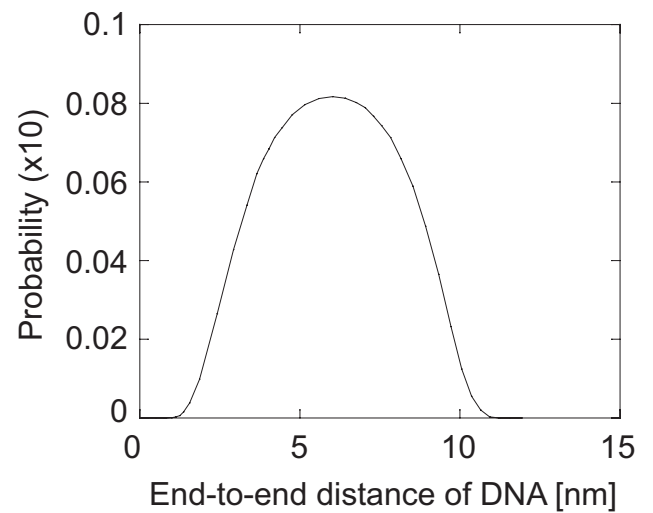

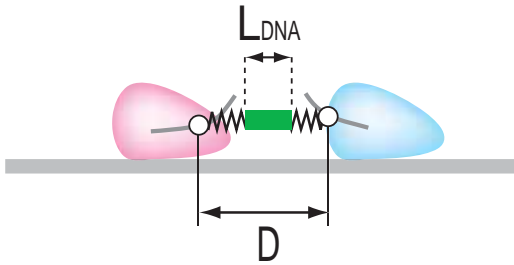
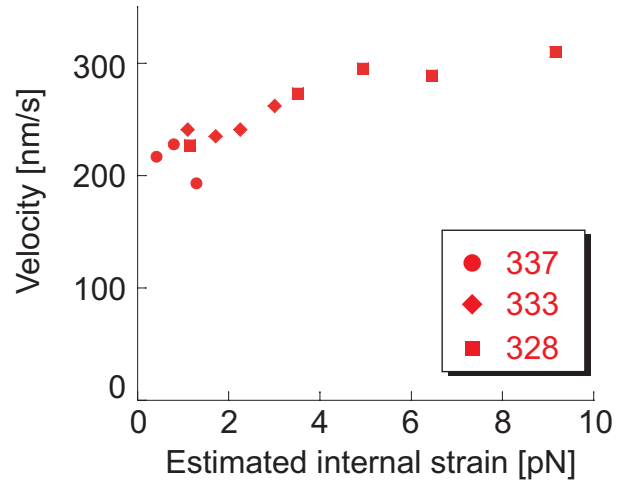
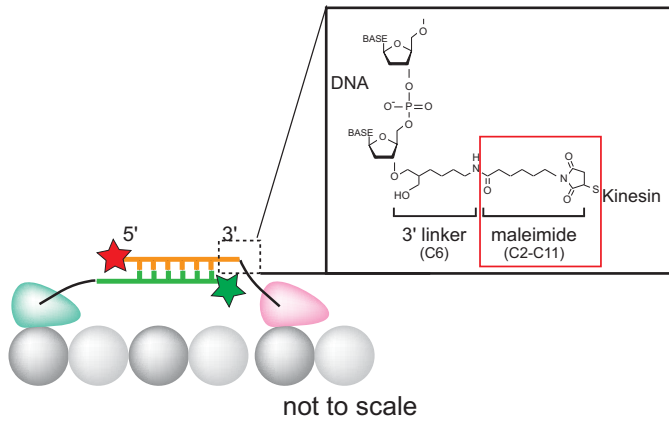
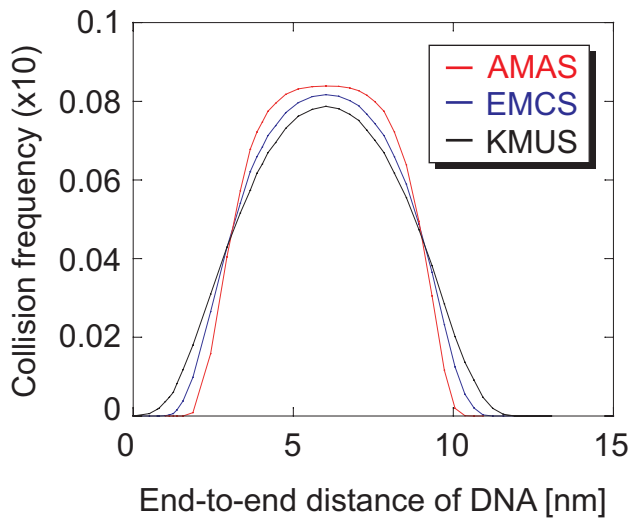
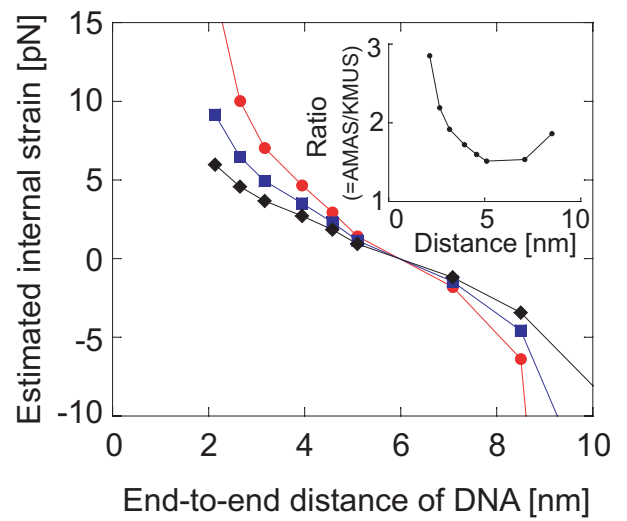
A**B****C****D****E**

A

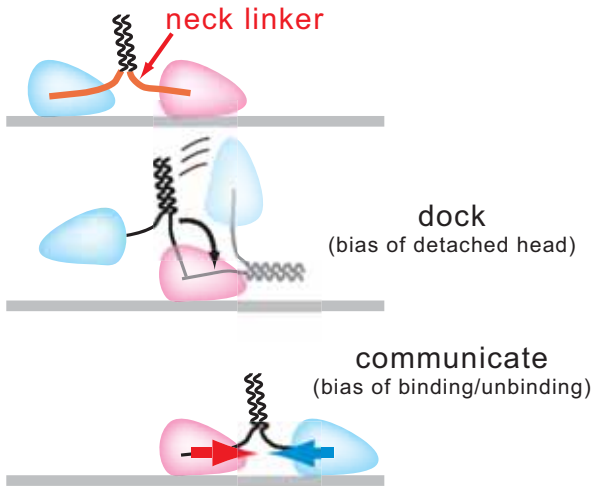

B

bias by docking

	○	×
○	C _{term}	— *
×	N _{term}	Mid

C

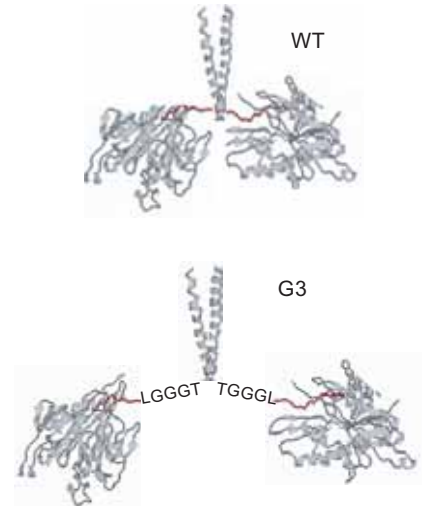
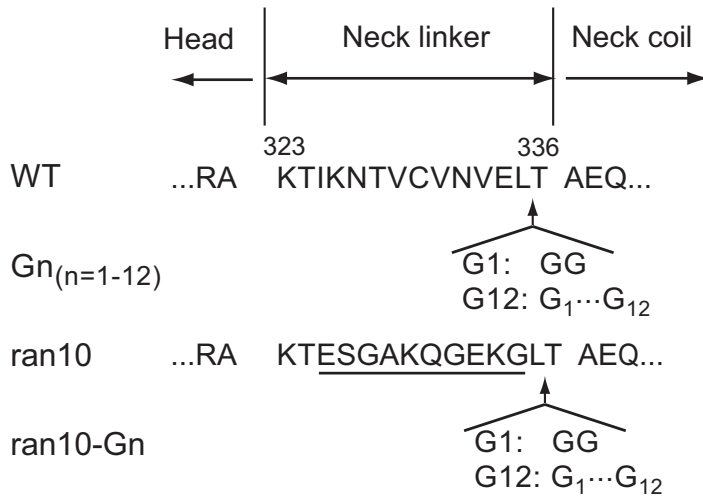

D

K324	...RA	KC
K325	...RA	KTC
K324G2	...RA	KTGGC
K324G7	...RA	KTGGGGGGGC

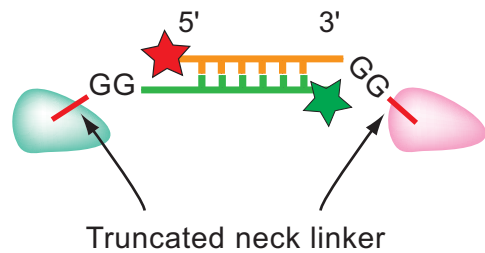

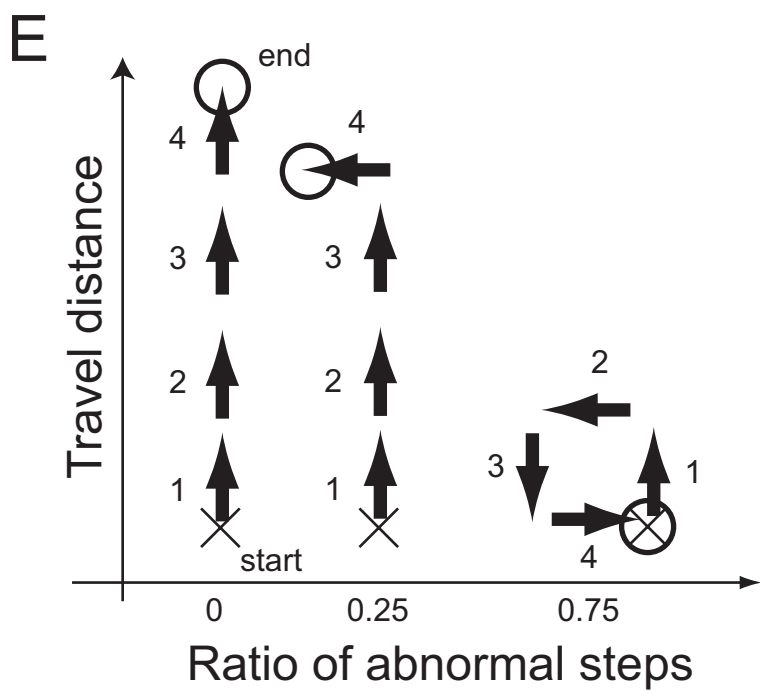
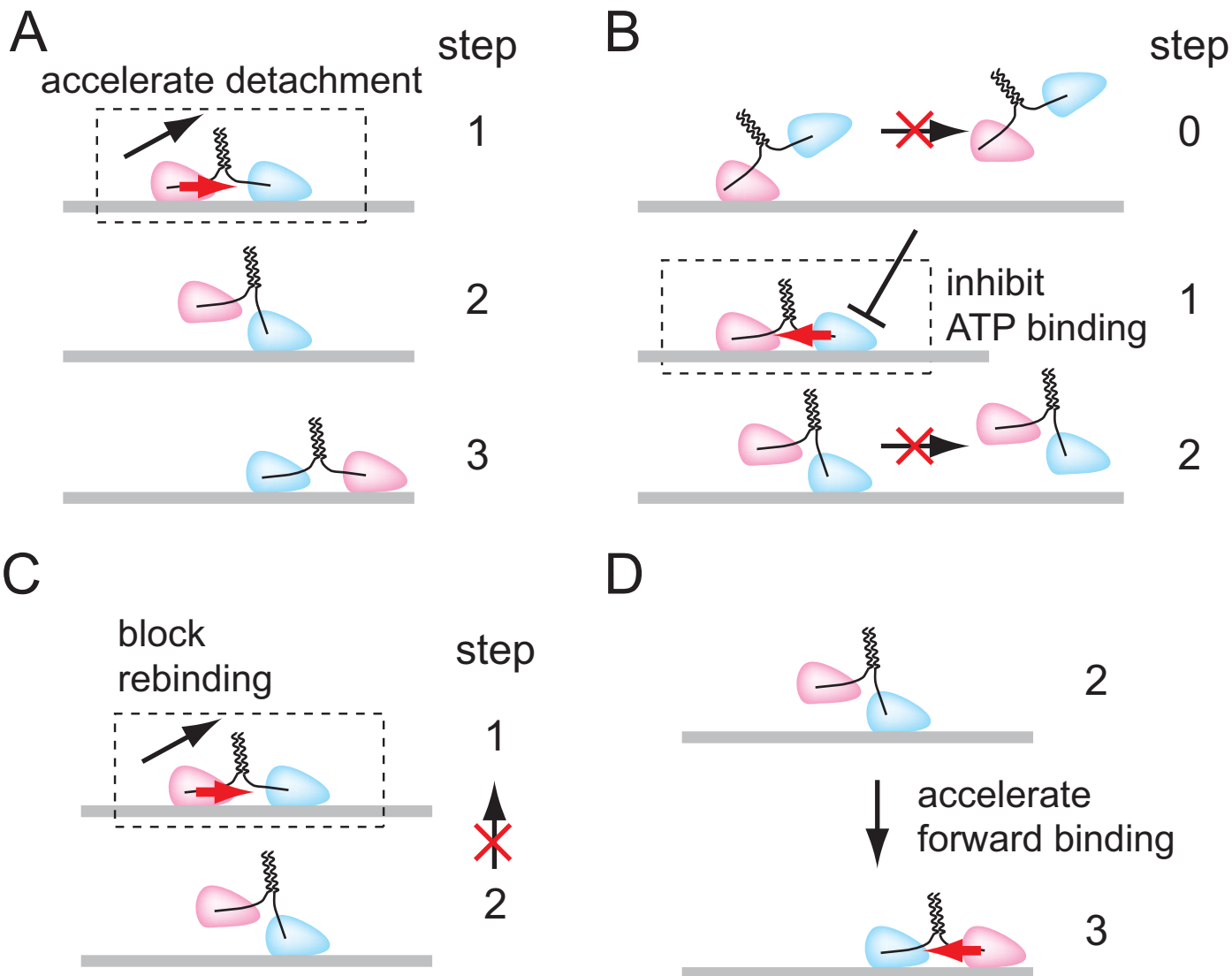

	name	[bp]	sequence
A	K20T13	33	GGATGGT <u>GGTACCCTT</u> CCCGTTTTTTTTTTTTTT
B	GC6_S	6	CCGCCC
	GC7_S	7	CCGCCCC
	GC8_S	8	GGGGCGGG
	GC10_S	10	CCCGTCCCCC
	K13_S	13	CGTGGTACCCTCC
	K15_S	15	TCGTGGTACCCTTCG
	K16_S	16	ATGGTGGTACCCTTCC
	K18_S	18	GATGGTGGTACCCTTCCC
	K20_S	20	GGATGGTGGTACCCTTCCCG
	K22_S	22	ATGGATGGTGGTACCCTTCTCG
	K25_S	25	CGGATGGATGGTGGTACCCTTCTCG
	K30_S	30	GAGCCGGATGGTGGTACCCTTCGCG TAGAG
	K35_S	35	GGAGAGCCGGATGGTGGTACCCTTCGCGTAGAGAG
K40_S	40	AGAGAGAGCCGGATGGTGGTACCCTTCGCGTAGAGAGAGA	
C	K8_S	8	<u>CGGTACCC</u>
	K10_S	10	TGGGTACCGC