

Molecular Cloning of Snyder-Theilen Feline Leukemia and Sarcoma Viruses: Comparative Studies of Feline Sarcoma Virus with Its Natural Helper Virus and with Moloney Murine Sarcoma Virus

CHARLES J. SHERR,^{1*} LOUIS A. FEDELE,¹ MARIANNE OSKARSSON,² JACOB MAIZEL,³ AND GEORGE VANDE WOUDE²

Laboratory of Viral Carcinogenesis¹ and Laboratory of Molecular Biology,² National Cancer Institute, and Laboratory of Molecular Genetics,³ National Institute of Child Health and Human Development, National Institutes of Health, Bethesda, Maryland 20205

Extrachromosomal DNA obtained from mink cells acutely infected with the Snyder-Theilen (ST) strain of feline sarcoma virus (feline leukemia virus) [FeSV(FeLV)] was fractionated electrophoretically, and samples enriched for FeLV and FeSV linear intermediates were digested with *EcoRI* and cloned in λ phage. Hybrid phages were isolated containing either FeSV or FeLV DNA "inserts" and were characterized by restriction enzyme analysis, R-looping with purified 26 to 32S viral RNA, and heteroduplex formation. The recombinant phages (designated λ FeSV and λ FeLV) contain all of the genetic information represented in FeSV and FeLV RNA genomes but lack one extended terminally redundant sequence of 750 bases which appears once at each end of parental linear DNA intermediates. Restriction enzyme and heteroduplex analyses confirmed that sequences unique to FeSV (*src* sequences) are located at the center of the FeSV genome and are ~1.5 kilobase pairs in length. With respect to the 5'-3' orientation of genes in viral RNA, the order of genes in the FeSV genome is 5'-*gag-src-env-c* region-3'; only 0.9 kilobase pairs of *gag* and 0.6 kilobase pairs of *env*-derived FeLV sequences are represented in ST FeSV. Heteroduplex analyses between λ FeSV or λ FeLV DNA and Moloney murine sarcoma virus DNA (strain m₁) were performed under conditions of reduced stringency to demonstrate limited regions of base pair homology. Two such regions were identified: the first occurs at the extreme 5' end of the leukemia and both sarcoma viral genomes, whereas the second corresponds to a 5' segment of leukemia virus "*env*" sequences conserved in both sarcoma viruses. The latter sequences are localized at the 3' end of FeSV *src* and at the 5' end of murine sarcoma virus *src* and could possibly correspond to regions of helper virus genomes that are required for retroviral transforming functions.

Infection of susceptible cells with RNA-containing retroviruses leads to the synthesis of a double-stranded DNA intermediate which integrates into the host cell genome and persists as a DNA provirus (2, 45). Both linear and circular forms of unintegrated DNA can be detected in acutely infected cells and can be analyzed after restriction endonuclease cleavage by the DNA transfer and hybridization technique ("blotting") originally described by Southern (41). Such studies have indicated that linear retroviral DNAs are from 300 to 1,200 base pairs longer than their respective RNA genomes and contain regions of extended terminal redundancy (ETR sequences), each derived from both the 5' and 3' ends of viral RNA (4, 6, 18, 19, 23, 34). The structure of linear DNA intermediates

has been designated 3'5'—3'5' where 3'5' represents a polar repeat sequence flanking the viral structural genes symbolized by — (34). An understanding of the patterns of restriction endonuclease cleavage sites within these molecules has enabled several laboratories to clone viral DNA in procaryotic host-vector systems (19, 49). The latter approach offers the possibility of directly analyzing purified viral DNA in great detail and of defining subsets of gene sequences required for viral transformation.

Type C viruses of the feline leukemia virus (FeLV) and sarcoma virus (FeSV) complex are horizontally transmitted in domestic cats and produce leukemias, lymphosarcomas, and fibrosarcomas in this species (reviewed in 14). Although many natural isolates of FeLV have been

obtained from infected animals, only three independent feline sarcoma viruses have been isolated (17, 27, 40), each in association with a different helper leukemia virus (31). Like other mammalian sarcoma viruses, each FeSV strain is replication-defective and lacks a certain portion of the genetic information found in its FeLV helper (16, 22, 25, 30, 33). By contrast, all FeSV's contain a subset of sequences unique to the sarcoma virus (designated *src* sequences) which are presumed to confer the properties of morphological transformation *in vitro* and acute sarcomagenesis *in vivo* (16).

To study the organization and derivation of the various gene sequences within FeSV, the Southern blot technique was used to generate a restriction map of linear viral DNA intermediates (35). The unintegrated DNAs of FeLV and FeSV were shown to be ~8.5 and 5.0 kilobase pairs (kbp) in length, respectively, each containing ETR sequences of ~0.75 kbp in length at both termini. The *src* sequences of FeSV were localized between 2.1 and 3.4 kbp from the 5' end (with respect to viral RNA) and are flanked by sequences derived from the helper virus. We now describe the cloning of these DNA molecules in the bacteriophage vector λ gtWES- λ B and a more detailed comparison of the specific gene sequences of Snyder-Theilen (ST) FeSV and FeLV. In addition, we present results of heteroduplex analyses performed between ST FeSV or FeLV and the cloned DNA of Moloney murine sarcoma virus (MSV, strain m₁) (49; G.F. Vande Woude, M. Oskarsson, W.L. McClements, L.W. Enquist, D. Blair, P.J. Fischinger, J.V. Maizel, M. Sullivan, Cold Spring Harbor Symp. Quant. Biol., in press) which show that certain specific helper virus-derived sequences are homologous to one another and have been conserved in the formation of two different, acutely transforming sarcoma viruses.

(A portion of this work was presented at the Seventh Cold Spring Harbor Conference on Cell Proliferation, Cold Spring Harbor, N.Y.)

MATERIALS AND METHODS

Viruses and cells. The ST strain of FeSV(FeLV) was generously provided by Arthur Frankel (Laboratory of Viral Carcinogenesis, National Cancer Institute) and was propagated in mink MvLU cells (American Type Culture Collection, CCL64). The FeLV helper virus in this stock is subgroup B (31; Rosenberg and Haseltine, personal communication). Focus-forming titers of FeSV were determined in mink cells (22), and the replicating helper virus titer was estimated by indirect focus formation in cat CCC clone 81 cells (15). The titer of FeSV was 3×10^5 focus-forming units per ml with a two- to fourfold excess of helper FeLV.

Purification of viral RNA. Viruses harvested at 12-h intervals from chronically infected cultures were

clarified of debris, pelleted, and banded isopycally in sucrose as described (5). Virions were disrupted with detergent and digested at 37°C with proteinase K, and viral RNA was extracted and precipitated with ethanol (35). Viral 50 to 60S RNA was obtained by velocity sedimentation in 15 to 30% neutral sucrose gradients (SW41 rotor; 38,000 rpm for 3.75 h) and reconcentrated under ethanol. For R-looping experiments, viral RNA was twice chromatographed on oligodeoxythymidylic acid-cellulose (type I, Collaborative Research, Waltham, Mass.) as described elsewhere (51) before sedimentation in neutral sucrose.

Preparation and characterization of cDNA transcripts. ³²P-labeled complementary DNA (cDNA) was synthesized in exogenous reactions with 50 to 60S viral RNA template, calf thymus DNA primer (length, 10 to 20 nucleotides), avian myeloblastosis virus polymerase, and actinomycin D exactly as previously described (35). Sequences representing the FeLV genome were obtained by hybridizing total FeSV(FeLV) cDNA to purified viral RNA obtained from the cloned helper virus. Hybridizations were performed in 0.01 M Tris-hydrochloride (pH 7.6), 1 mM EDTA, 0.05% sodium dodecyl sulfate, and 0.65 M NaCl at 68°C (final C_t, 5.0 mol·s/liter). cDNA:RNA hybrids were digested with the single-strand-specific nuclease S₁ (1, 5) and separated from single-stranded cDNA on hydroxyapatite at 60°C (9), and duplexes were treated with alkali, neutralized, and concentrated under ethanol (35). ³²P-labeled FeLV cDNA transcripts were ~6S in size as determined by sedimentation in alkaline sucrose gradients. The cDNA hybridized to final extents of 90% with FeSV(FeLV) and FeLV RNA but to less than 2% with total cellular RNA from mink cells (C_t > 10⁴ mol·s/liter) with stringent S₁ nuclease conditions to detect hybrids (5). The transcripts were >98% sensitive to digestion with S₁ nuclease and chromatographed only as single strands on hydroxyapatite.

Purification of extrachromosomal DNA. Extrachromosomal DNA from mink cells acutely infected with ST FeSV(FeLV) was purified by differential sedimentation and chromatography (38) as previously described (35). The ratios of the absorbance of purified DNA at 260 nm to that at 280 nm were all greater than 1.9, and the yield was less than 1% of the total cellular DNA. In general, 5 to 10 μ g of DNA was recovered per 890-cm² roller bottle infected at 70% confluency. Total extrachromosomal DNA (~150 μ g) was fractionated by preparative agarose gel electrophoresis (49), and lyophilized fractions were each suspended in 50 μ l of 40 mM Tris-acetate containing 2 mM EDTA (TEA buffer); 1- μ l portions were scored for the presence of viral DNA intermediates with analytical gel electrophoresis, transfer and immobilization to nitrocellulose, and hybridization with ³²P-labeled FeSV(FeLV) cDNA (35, 41). Fractions enriched for the linear DNA intermediates of FeSV (5.0 kbp) and FeLV (8.5 kbp) (35) were taken for recombinant DNA procedures.

Construction and identification of hybrid phages. Fractionated preparations enriched for FeSV and FeLV molecules were digested with *Eco*RI (Boehringer Mannheim, Indianapolis, Ind.) and ligated to purified vector arms obtained from the EK2-certified

bacteriophage vector λ gtWES- λ B (49; Vande Woude et al., in press); ligated vector-substrate DNAs were packaged in vitro into lambda particles as described by Enquist and Sternberg (L.W. Enquist and N. Sternberg, *Methods Enzymol.*, in press). After titers of recombinant phage were determined, portions of the packaging reactions were plated on *Escherichia coli* strain LE392 to give ~200 plaques per plate. Hybrid phage particles containing FeLV cDNA-related sequences were identified by a plaque-blot method as previously described (49). Plaques containing putative viral DNA recombinants were subcloned and propagated on *E. coli* DP50 *sup* F, and recombinant DNA was extracted (49; Vande Woude et al., in press). All procedures were performed in containment facilities in accordance with the National Institutes of Health Guidelines for Recombinant DNA Research.

Purification of DNA inserts. Hybrid phages containing FeSV and FeLV DNA (designated λ FeSV and λ FeLV) were digested with *Eco*RI before electrophoresis on 0.8% agarose gels. The DNA inserts were electroeluted from the gels (26, 35) and concentrated under ethanol.

Ultrastructural studies. The techniques used for heteroduplexing of FeLV and FeSV DNA inserts and for R-looping (47) of λ FeSV and λ FeLV were performed exactly as described (49; Vande Woude et al., in press). Heteroduplexes were formed with equal quantities of each insert. The formation of heteroduplexes between either λ FeLV or λ FeSV and a hybrid phage containing the m_1 strain of Moloney MSV [λm_1 MSV (49)] was performed in solution containing 50% formamide at 25°C instead of at 37°C.

Restriction endonuclease analyses. *Bam*HI, *Bgl*II, *Kpn*I, *Hind*III, *Hae*III, and *Hpa*I were purchased from Bethesda Research Laboratories (Bethesda, Md.) and *Xho*I, *Xba*I, *Pst*I, and *Sal*I were obtained from New England Biolabs (Beverly, Mass.). Cloned DNAs were digested with a slight excess of enzyme units over substrate (37°C for 2 h), and the products were heated for 10 min at 65°C and electrophoretically separated on 1.2 to 2.2% agarose in TEA buffer (34, 35). DNA bands were visualized by direct staining with 1 μ g of ethidium bromide per ml. In certain cases, cloned DNAs were also transferred to nitrocellulose and subsequently scored by hybridization with [³²P]cDNA; when cloned DNA was used, the transfer period was reduced to as little as 2 h, and autoradiography was seldom performed for more than 1 h. Dual digestions were performed as described elsewhere (35). To confirm restriction endonuclease cleavage site assignments, individual fragments from single digests were purified by electroelution and subjected to digestion with other enzymes. Electrophoretic standards included 1:1 mixtures of *Eco*RI and *Hind*III digests of bacteriophage λ and *Hae*III digests of ϕ X174 DNA.

RESULTS

Cloning of FeSV and FeLV linear DNA intermediates. To obtain preparations enriched for viral DNA intermediates, extrachromosomal DNA was obtained from mink cells 24 h after infection with ST FeSV(FeLV). Total

extrachromosomal DNA was fractionated by preparative gel electrophoresis, and each fraction was concentrated and tested for the presence of viral DNA by the procedure of Southern (41). Figure 1 shows that four major species were detected with ³²P-labeled FeSV(FeLV) DNA. Based on independent chemical and biological criteria, it was previously established that the 8.5- and 5.0-kbp bands represent the full-length linear DNA intermediates of ST FeLV and FeSV, respectively; the other major bands represent deleted FeLV linear DNA forms (35). Fractions enriched for 8.5- and 5.0-kbp DNA molecules (fractions 13 and 17) were chosen for further studies.

The restriction endonuclease *Eco*RI cleaves only within the terminal repeat sequences of both ST FeLV and FeSV linear molecules, removing 0.3 to 0.4 kbp from each end of viral DNA and reducing the length of each molecule by approximately 750 base pairs (35). The DNA preparations were therefore digested with *Eco*RI, ligated to the large *Eco*RI fragments of λ gtWES- λ B, and packaged in vitro into phage particles. Approximately 10⁶ PFU of phage per μ g were obtained with the DNA of fraction 13 and about 10⁵ PFU/ μ g with fraction 17. For each DNA preparation, 0.3 to 1.0% of the phage plaques hybridized to viral cDNA. The high frequency of viral DNA recombinants is due to several factors. First, the fractionated extrachromosomal DNA preparations were highly enriched (100 to 200 copies per cell) for viral DNA sequences as determined by liquid hybridization techniques (*C*₀t analysis) (35). Second, in vitro

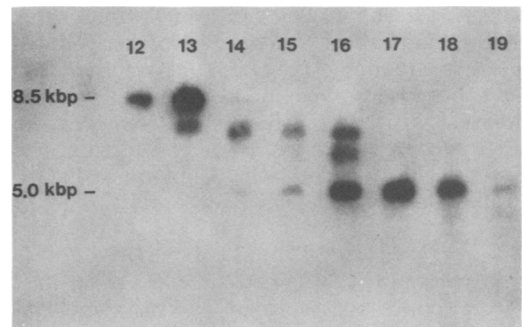

FIG. 1. FeSV(FeLV) DNA intermediates isolated from acutely infected mink cells. A preparation of extrachromosomal DNA was separated by preparative electrophoresis in agarose, and portions of each fraction were studied analytically by the technique of Southern (41). Hybridization was performed with total ³²P-labeled FeSV(FeLV) cDNA. The 8.5- and 5.0-kbp bands represent linear, full-length intermediates of FeLV and FeSV, respectively. Fractions 13 and 17 were taken for recombination with the long arms of λ gtWES- λ B.

packaging of competent recombinant phage in this system requires *EcoRI*-digested DNA molecules of a restricted size class (generally between 2 and 17 kbp) (13, 44; Enquist and Sternberg, in press). Ligation of purified vector "arms" lacking interposed DNA molecules does not result in the formation of lytic phage; hence, all plaques contain recombinant DNA molecules (46). Third, although each viral DNA molecule contains terminal *EcoRI* sites and is only reduced in size by 0.75 kbp after restriction, non-viral cellular DNA contaminants would have a lower probability of containing two *EcoRI* sites located at each DNA terminus. *EcoRI* digestion of susceptible nonviral DNA molecules would therefore be expected to significantly reduce their size and decrease their probability of being packaged into competent phage (13).

Four representative phage clones from each packaging reaction were twice subcloned, and each was retested by plaque blotting to confirm the presence of viral gene sequences. The recombinant phages were then grown up and concentrated, and their DNA was extracted. After digestion of the DNA preparations with *EcoRI*, the size of the cloned DNA inserts was measured by agarose gel electrophoresis and ethidium bromide staining of DNA fragments. Based on the lengths of parental DNA molecules, the lengths of cloned FeLV and FeSV DNAs were expected to be ~0.75 kbp shorter than the full-length DNA intermediates. All four FeLV-derived clones contained 7.8-kbp inserts, although one clone also contained an additional 4.8-kbp insert of nonviral origin. The latter clone was not studied further. By contrast, of four clones derived from the FeSV DNA preparation, only one contained a 4.3-kbp insert, whereas the remainder contained 7.8-kbp FeLV DNA. These results reflect the fact that closed circular forms of FeLV DNA comigrate with linear FeSV DNA forms in preparative agarose gels and represented ~20% of the total viral DNA in FeSV preparations (35). Circular FeLV molecules are converted to linear 7.8-kbp forms after *EcoRI* digestion and, because of their greater relative length, would be expected to be packaged preferentially into replicating phage particles (13). Both the 7.8- and 4.3-kbp *EcoRI*-digested DNA fragments hybridized with radiolabeled FeLV cDNA. The hybrids were designated λ FeLV and λ FeSV, respectively.

The 5'-3' orientation with respect to viral RNA of each cloned insert within the λ vector was next determined by digestion of λ FeSV and λ FeLV with *BglII*. This enzyme cleaves at a site close to the 5' end of both FeSV and FeLV DNA and also recognizes a second cleavage site near the center of the FeLV genome (35 and Fig. 2).

For both λ FeSV and λ FeLV, *BglII* digestion yields two junctional fragments, each containing both viral and vector DNA. Because the positions of *BglII* cleavage sites in the λ gtWES vector are known, the sizes of the junctional fragments can be used to orient the inserted sequences with respect to the long and short vector arms. By this analysis, the λ FeSV and two of the λ FeLV clones were found to contain inserts in 5'-3' orientation, whereas five λ FeLV clones were oriented 3'-5' with respect to viral RNA.

Restriction endonuclease analyses of cloned FeSV and FeLV DNA. Figure 2 shows the sites of restriction endonuclease cleavage for several different enzymes in FeSV and FeLV DNA. The sites of cleavage for the various enzymes were first deduced from indirect analyses of viral DNA intermediates by the Southern transfer technique (35). Comparative studies with cloned DNAs showed that restriction endonuclease sites in purified FeSV and FeLV DNA inserts were identical to those in parental molecules except that the cloned DNAs lacked the terminal portions of each ETR sequence and were each 750 base pairs shorter. The sequences deleted from the cloned DNA molecules are indicated by the dashed, boxed segments in the line drawing of Fig. 2.

A comparative analysis of the FeSV and FeLV DNA maps suggests that sequences at the extreme 5' termini of both classes of molecules are similar. The 5' ends of both FeSV and FeLV include two characteristic sites (for *KpnI* and *EcoRI*) mapping within the left-hand ETR region and the 5' *BglII* site ~0.35 kbp to the right of the ETR sequence. Another characteristic group of restriction sites for *PstI*, *XhoI*, and *BamHI* map between 5.8 and 6.2 kbp on the FeLV map and also appear between 3.4 and 3.8 kbp on the FeSV map. With the exception of the restriction sites in the right-hand ETR sequence, these are the only other sites shared between FeSV and FeLV DNAs.

All other restriction enzyme sites fall into regions which appear to be specific to either FeLV or FeSV. By indirect methods, the FeSV *src* sequences were estimated to map within 2.1 and 3.4 kbp from the 5' end of FeSV DNA (35). Thus, the *PstI*, *KpnI*, and *SalI* restriction sites assigned to this region represent a cleavage pattern unique to FeSV DNA. Similarly, a large number of restriction sites located between 2.0 and 5.8 kbp on the FeLV map, as well as two additional cleavage sites for *KpnI* and *HindIII* at ~7.2 kbp, define patterns of digestion unique to FeLV. In particular, several of these enzymes (*HindIII*, *HpaI*, and *XbaI*) fail to digest FeSV DNA.

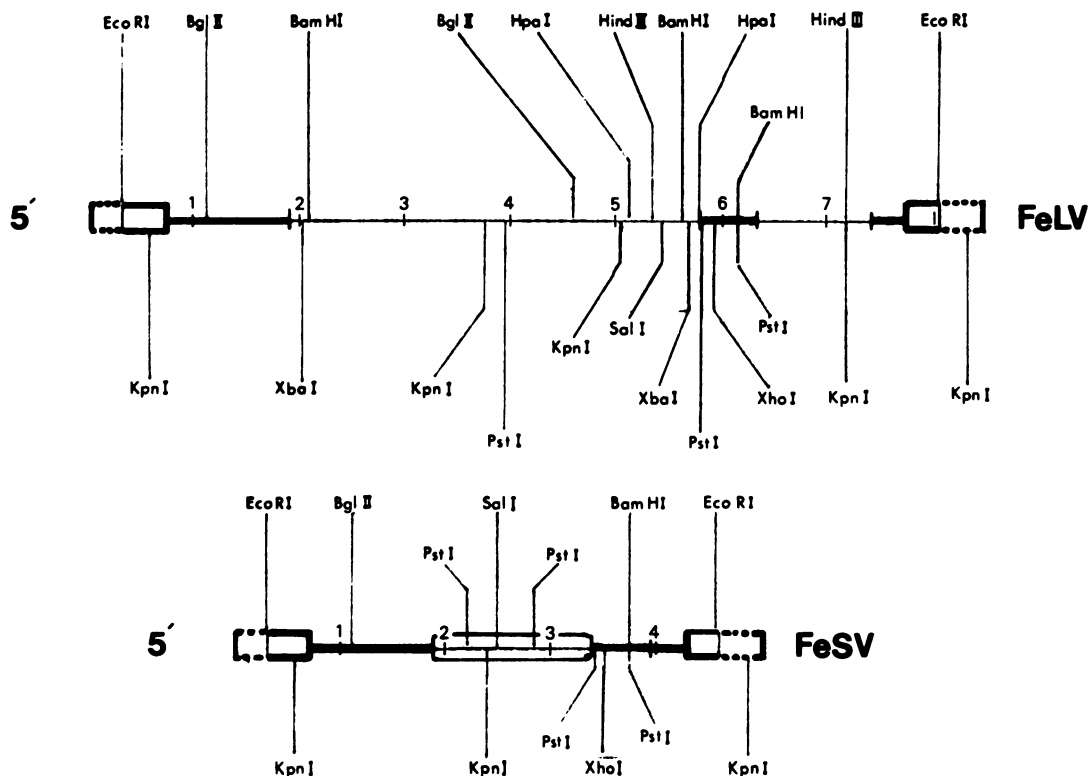

FIG. 2. Composite maps of ST FeLV and FeSV. The maps are oriented from 5' to 3' with respect to viral RNA. Measurements are in kbp. The full-length linear DNA intermediates of FeLV and FeSV are ~8.5 and ~5.0 kbp, respectively. The terminal repeats (0.75 kbp in length) are indicated by rectangles at the ends of the molecules. Cloned FeLV and FeSV DNAs lack those portions of ETR sequences distal to the *EcoRI* sites at each end of linear DNA molecules and are 7.8 and 4.3 kbp in length, respectively. The heavy lines indicate sequences shared in common between FeLV and FeSV, whereas light lines show the extent of sequences unique to each virus. The lengths of shared sequences were obtained from measurements of heteroduplexes and were aligned with respect to sites of restriction endonuclease cleavage. The internal rectangle in FeSV DNA localizes the position of *src* sequences.

R-loop analyses. As further confirmation of the identity of the cloned viral DNA sequences, 26 to 32S polyadenylic acid-containing FeSV(FeLV) RNA was purified from virions and was hybridized to either λ FeLV or λ FeSV under conditions which favor DNA:RNA versus DNA:DNA duplexes (47). By using these methods, RNA displaces the DNA strand of identical polarity which is observed as a characteristic R-loop. The length of the R-loop will therefore correspond to the region of duplex formed between cloned DNA and viral RNA. The cloned DNA inserts of FeSV and FeLV differ slightly from viral RNAs in that sequences derived from the 3' end of each RNA appear at the extreme 5' end of the respective cloned DNA inserts. Based on the length of the 5'-end-derived sequences appearing within the ETR regions (~140 base pairs), we estimated that ~0.3 kbp of 3'-derived sequences would be present in the

left-hand ETR region of both DNA inserts. It was therefore anticipated that homologous viral RNAs would hybridize in a contiguous fashion from their 5' ends (i.e., beginning at a region close to the *KpnI* sites in the left-hand ETR sequences) to the extreme, right-hand *EcoRI* site. If this were the case, the lengths of R-loops formed with full-length homologous viral RNAs would be 0.3 kb shorter than the cloned DNA inserts: that is, 7.5 and 4.0 kbp for FeLV and FeSV, respectively. Since the sequences at the extreme 3' end of viral RNA are permuted to the 5' end of the cloned DNA inserts, we further expected to observe single-stranded RNA tails representing 3'-derived sequences plus polyadenylic acid. By using either λ FeSV or λ FeLV containing inserts in 5'-3' orientation, the single-stranded RNA tails would appear adjacent to the right-hand 14-kbp λ vector arm.

Figure 3 shows representative R-loop struc-

tures obtained with λ FeSV and λ FeLV. Length measurements were obtained for 25 different molecules formed with each DNA. The average lengths of the observed loop structures were 3.84 ± 0.38 and 8.06 ± 0.88 kb for FeSV and FeLV, respectively. RNA tails were observed at the ends of the R-loops adjacent to the right vector arm consistent with the 5'-3' orientation deduced by *Bgl*II cleavage. These studies confirmed the identity of both cloned DNA inserts.

Heteroduplex analyses of FeLV and FeSV DNA. To obtain a visual comparison of the regions of homology between FeLV and FeSV, hybrid phage DNA was digested with *Eco*RI, and the purified inserts were heteroduplexed. Figure 4 shows two representative structures. The double-stranded regions define se-

quences shared in common between FeSV and FeLV (*com* sequences), whereas unpaired regions of nonhomology and deletion loops reflect unique sequences within the two genomes. The heteroduplexes are depicted in the line drawing at the bottom of Fig. 4 in 5'-3' orientation with respect to viral RNA. Twenty-five heteroduplexes were measured, and the lengths of various segments are in kbp (or kb). Figure 4 shows that both genomes are homologous at their 5' termini. Beginning 1.6 ± 0.12 kbp from the 5' end, a region of nonhomology is seen representing 3.9 ± 0.38 kb of FeLV and 1.5 ± 0.15 kb of FeSV DNA. The latter sequence, representing a region unique to the sarcoma virus, defines the limits of the FeSV *src* gene. At the 3' end of the molecules, a 1.2 ± 0.14 -kbp double-stranded re-

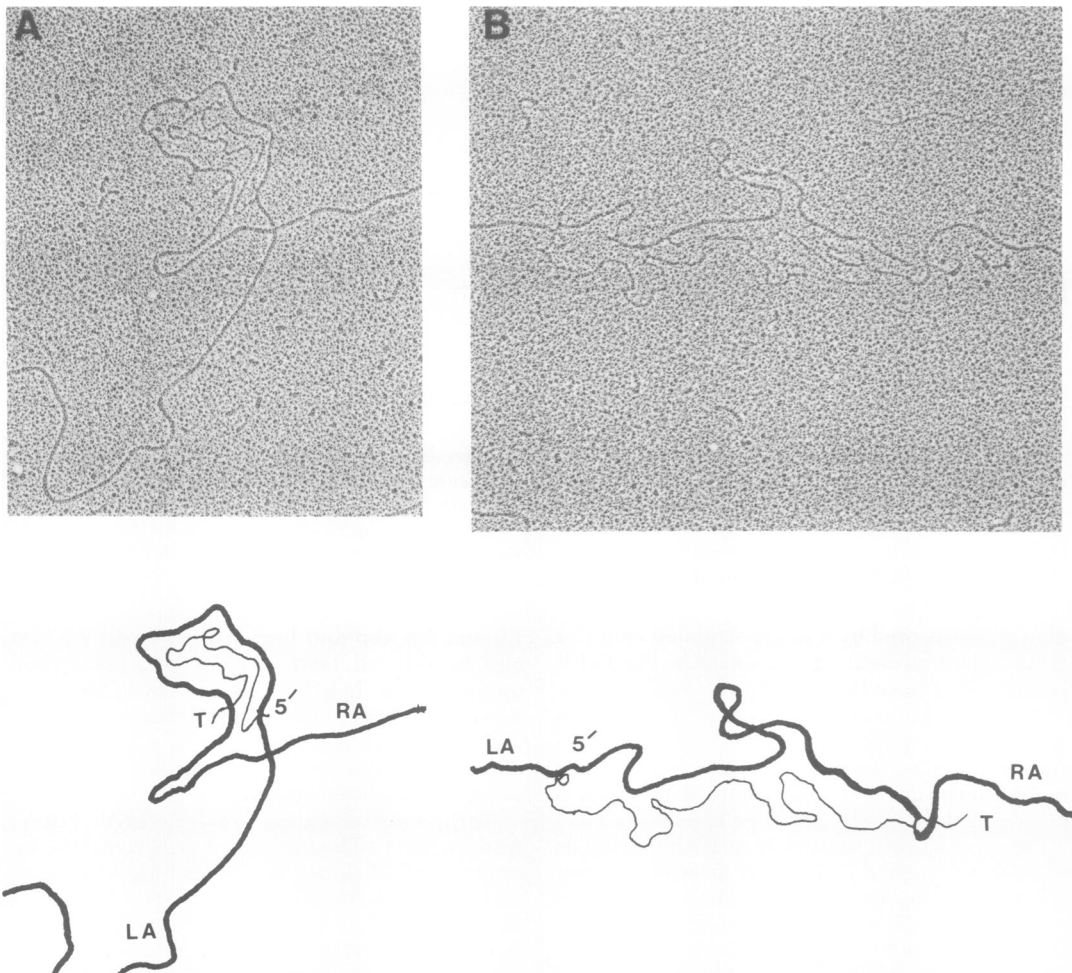

FIG. 3. R-loops between ST FeSV(FeLV) 26 to 32S polyadenylic acid-containing RNA and the DNA of λ FeSV (A) and λ FeLV (B). The single-stranded "tails" (T) near the right λ arm represent ~ 0.3 kb of sequences (plus polyadenylic acid) at the extreme 3' end of viral RNA which are permuted to the 5' end of the cloned DNA inserts.

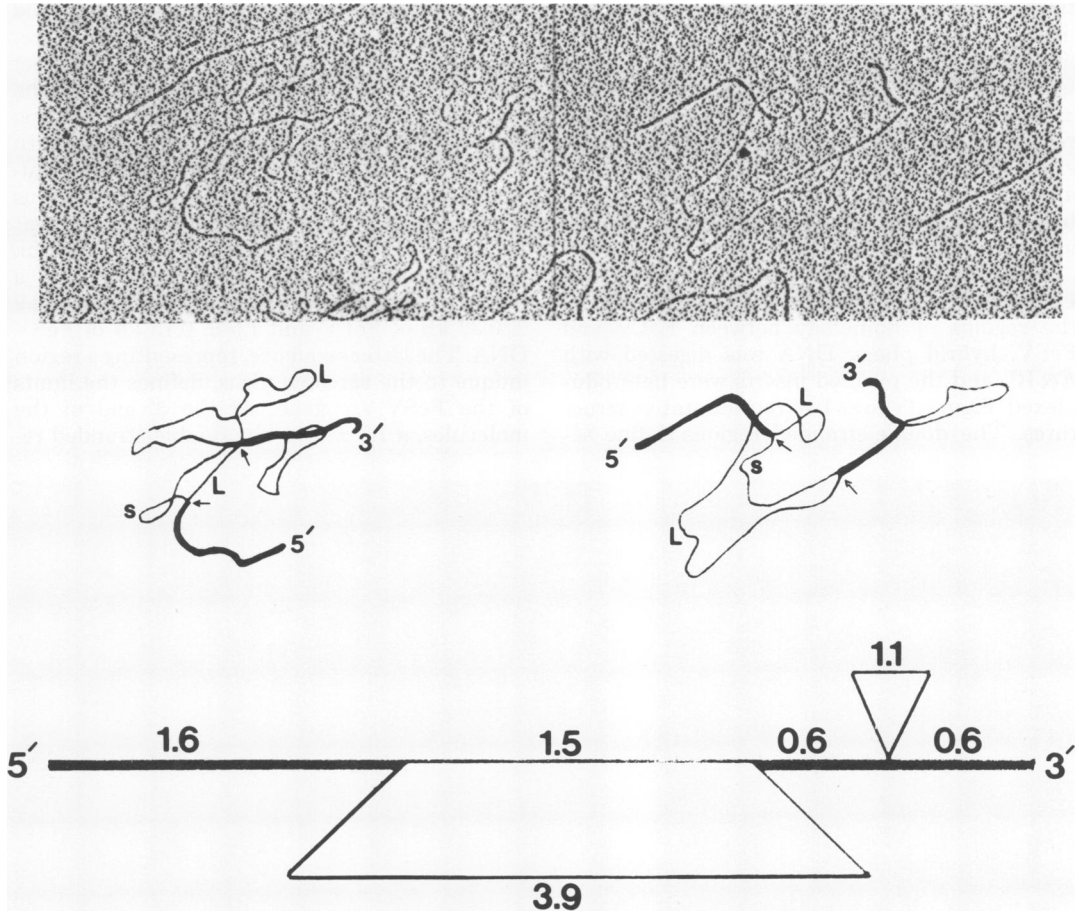

FIG. 4. Two micrographs of representative FeLV:FeSV heteroduplexes (top) are shown together with traces of the structures (middle). The heavy lines in the traces indicate duplex regions; L and s designate single-strand regions of FeLV and FeSV DNA, respectively, and arrows denote the extents of the internal, single-strand loop structure. The lower line drawing defines a typical heteroduplex in 5'-3' orientation with respect to viral RNA. The numbers above various segments indicate the average contour lengths in kbp (standard deviation <math>< \pm 10\%</math>) from 25 molecules (See text).

gion is interrupted by a single-stranded loop (1.1 \pm 0.13 kb) representing sequences in the FeLV genome that have been deleted in FeSV.

The data obtained by heteroduplex analysis were combined with those obtained by restriction endonuclease studies to create the physical maps shown in Fig. 2. The homologous regions are defined by the heavy lines and include the ETR and adjacent sequences at both termini as well as a sequence (~0.6 kbp) located between 5.8 and 6.4 kbp on the FeLV map. The latter segment includes the characteristic group of restriction sites defined by *Pst*I, *Xho*I, and *Bam*HI (which also appear at 3.4 to 3.8 kbp on the FeSV map) and can be aligned just adjacent to a *Hpa*I site which is missing in FeSV DNA. Nonhomologous regions within FeLV DNA map between

1.9 and 5.8 kbp and between ~6.4 and 7.5 kbp and include all restriction endonuclease sites unique to the helper virus. By these analyses, FeSV *src* sequences were positioned between 1.9 and 3.4 kbp on the map (cf. Fig. 2, inset), consistent with the previous localization of these sequences by other techniques (35).

Comparative studies of ST FeSV, FeLV, and m₁ MSV. The integrated provirus of the m₁ strain of MSV cloned in λ phage (λ m₁) has been extensively characterized (49; Vande Woude et al., in press); λ m₁ was cloned from transformed mink cellular DNA and contains, in addition to the MSV provirus, 0.2 and 1.6 kbp of flanking host cellular sequences at the 5' and 3' ends of MSV DNA, respectively. To determine whether homology exists between MSV and FeSV se-

quences, the phage λ recombinants were heteroduplexed at 25°C instead of 37°C in the vector so that the right and left arms of λ would facilitate duplex formation.

Figure 5A shows a representative structure formed after annealing λm_1 MSV and λ ST FeSV DNA. The duplexed regions at the ends of these molecules represent base pairing between the homologous λ vector arms. The long arm of the λ vector is contiguous with the 5' ends of both DNA inserts. Heteroduplexes between λm_1 MSV and λ ST FeSV are characterized by two limited segments of duplex formation and three regions of nonhomology. At the end of the long vector arm, the first nonhomologous region contains 0.71 ± 0.07 kb of MSV and 0.11 ± 0.02 kb of FeSV sequences. This region is followed by a short duplexed segment (0.6 ± 0.26 kbp) and a second region of nonhomology composed of 2.2 ± 0.16 kb of MSV and 2.5 ± 0.29 kb of FeSV sequences. A second segment of homology, 0.3 ± 0.04 kbp in length, terminates in the third single-stranded region containing 3.5 ± 0.30 kb of MSV and 1.0 ± 0.28 kb of FeSV sequences. The different regions of these structures are depicted in the upper panel of Fig. 6. The 5' unpaired region of λm_1 MSV contains a ~ 0.2 -kbp segment of host cellular flanking sequences present exclusively in this recombinant plus ~ 0.5 kbp of the MSV ETR sequence (0.6 kbp) (6, 18, 49; Vande Woude et al., in press). This suggests that the adjacent 5' homology region consists of a portion of the MSV and FeSV ETR sequences (~ 100 bases) plus an additional 500 base pairs. The second single-stranded region includes sequences mapping between ~ 1.1 and 3.5 kbp on the FeSV map and ending at the 3' end of the FeSV *src* sequence as well as ~ 2.2 kbp of MSV sequences which terminate ~ 0.3 kb away from the 5' end of the MSV *src* gene. Thus, the second 0.3-kbp duplex represents base pairing between sequences just to the 3' end of FeSV *src* and just to the 5' end of MSV *src*. The third nonhomologous region includes the remainder of the cloned FeSV DNA sequences and the rest of the MSV insert (1.1 kb of *src*, 0.2 kb of *c*-region sequence, 0.6 kb of ETR region, and 1.6 kb of host cell flanking sequence).

The above results suggested that the two regions of homology detected between λ ST FeSV and λm_1 MSV were derived exclusively from helper viral sequences represented in the two sarcoma viral genomes. Based on the physical map shown in Fig. 2, the 0.6-kbp homology region would also be represented near the 5' end of FeLV DNA, whereas the 0.3-kbp region of homology would correspond to a sequence mapping between ~ 5.9 and 6.2 kbp on the FeLV

map. We therefore performed comparative heteroduplex analyses with λ FeLV instead of λ FeSV. A representative structure is shown in Fig. 5B and is depicted in the bottom panel of Fig. 6.

Like heteroduplexes formed between λm_1 MSV and λ FeSV, two regions of homology were detected with λ FeLV. At the end of the long vector arm, the first single-stranded region contained 0.53 ± 0.17 kb of MSV and 0.19 ± 0.05 kb of FeLV sequences. This segment again included both the flanking cellular sequences and the majority of ETR sequences of λm_1 MSV, as well as a portion of the FeLV ETR sequence, and terminated at a 1.56 ± 0.16 -kbp homology region. An examination of 25 molecules showed that the latter segment was poorly base paired even under the low stringency conditions used: that is, many small single-stranded bubbles were seen throughout this region with extensive variation in their locations in the different analyzed molecules. The second region of nonhomology included 3.69 ± 0.49 kb of FeLV and 0.56 ± 0.20 kb of MSV sequences and terminated in a short 0.50 ± 0.18 -kbp duplexed segment. These measurements served to position the short homology region on the FeLV map (~ 5.7 to 6.2 kbp; Fig. 6), confirming its predicted location and its homology to sequences near the 5' end of the MSV *src* sequence. The third single-stranded region contained sequences at the 3' end of FeLV DNA (2.1 ± 0.23 kb), as well as the 3' MSV sequence (3.52 ± 0.25 kb).

DISCUSSION

Linear DNA intermediates of ST FeSV and FeLV cloned in a bacteriophage λ vector have been used to compare the structure of FeSV DNA with that of its natural helper virus and with the cloned DNA of MSV. The results of restriction enzyme, R-looping, and heteroduplex analyses between FeSV and FeLV DNAs indicate that the cloned DNA molecules are identical to parental linear DNA intermediates formed in cells infected with FeSV(FeLV), except that the cloned DNAs lack the terminal portions of each ETR sequence and are 0.75 kbp shorter than the full-length DNA proviruses. Thus, although λ FeSV and λ FeLV hybrid phages contain all of the genetic information represented in FeSV and FeLV RNA genomes, only one ETR sequence is present and appears in a permuted form in each cloned DNA molecule. As predicted from previous nucleic acid hybridization studies performed with FeSV DNA restriction fragments (35), *src* sequences were localized at the center of FeSV DNA and are flanked by sequences shared in common with the helper virus

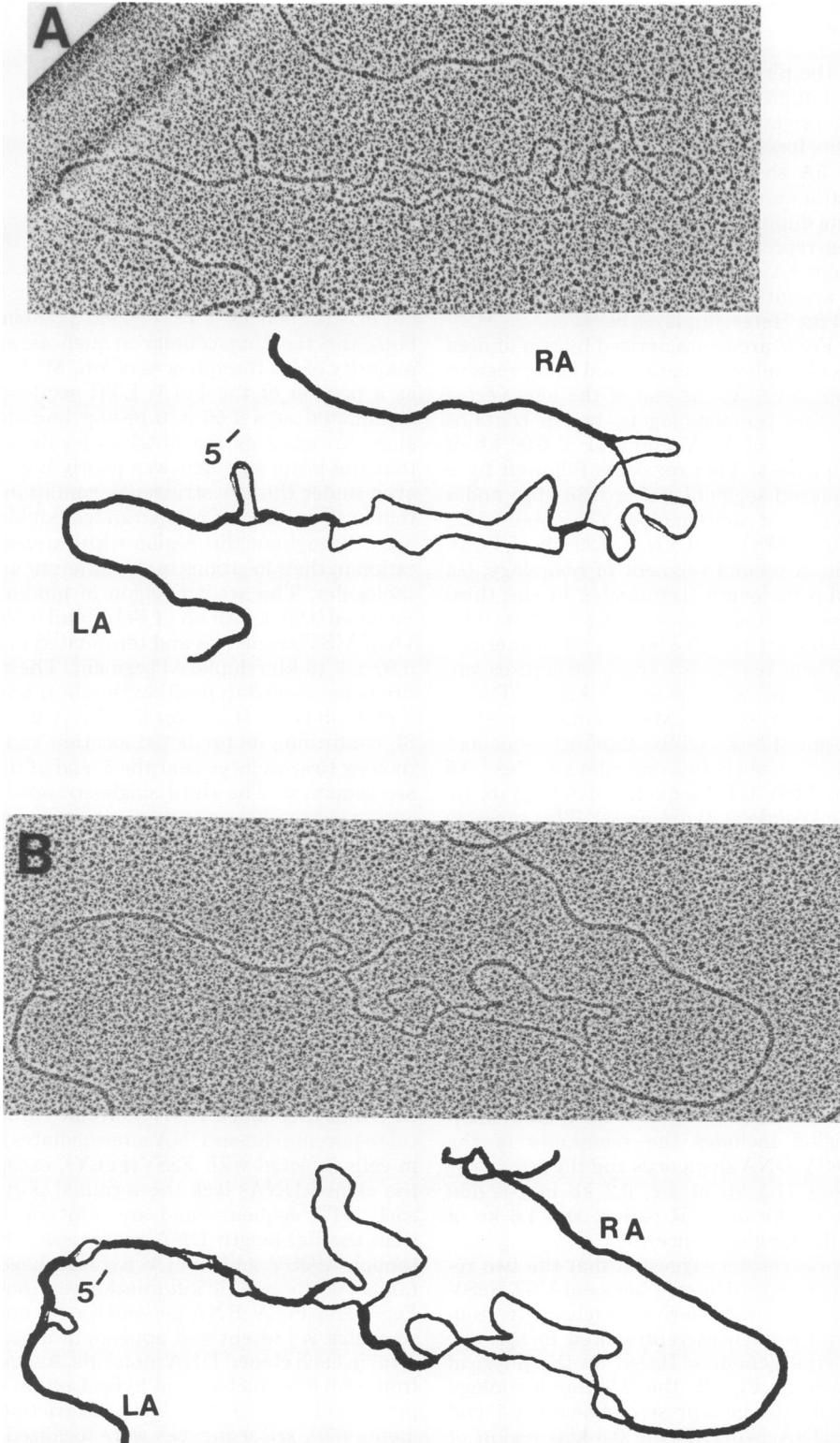

FIG. 5. Comparative heteroduplexes between λ_m , MSV and λ_{FeSV} (A) or λ_{FeLV} (B). The heavy lines in the traces represent duplexed regions. The duplexed left arm (LA) and right arm (RA) of the vector sequences are indicated in the tracing. This served to orient the 5' ends of the viral genomes (so indicated).

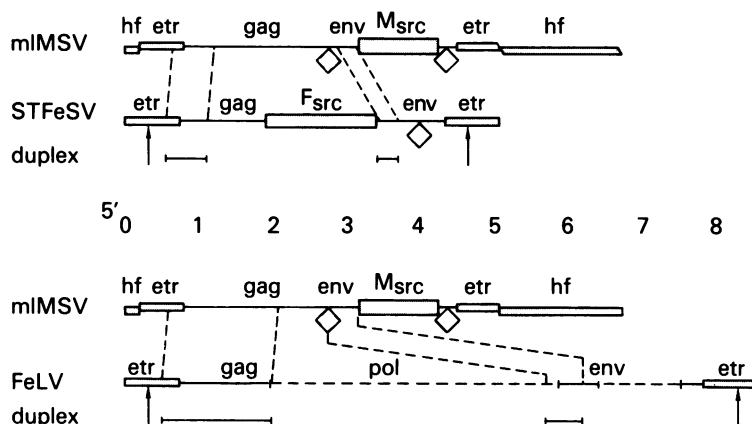

FIG. 6. Maps of heteroduplexes between the DNAs of m_1 MSV and FeSV (top) and between m_1 MSV and FeLV (bottom). The linear scale is in kbp. The darkened segments labeled hf designate host flanking cellular sequences ~ 0.2 kbp and 1.6 kbp in length at the 5' and 3' ends of the λm_1 MSV insert, respectively. The positions of duplexed regions are indicated by the vertical dashed lines and by the horizontal bars below the FeSV and FeLV maps. Regions corresponding to extended terminal repeats (etr), gag, pol, env, and src sequences are designated. The diamonds designate the sites of deletion of helper viral sequences in both sarcoma viruses. FeLV sequences deleted in FeSV are also indicated by the horizontal dashed lines in the lowest line drawing. Arrows indicate sites of EcoRI cleavage in FeSV and FeLV DNA. The orientation is from 5' to 3' with respect to viral RNA.

(com sequences). The com sequences at the 5' end of FeSV originate from sequences present at the extreme 5' end of FeLV; by contrast, com sequences at the 3' end of FeSV derive from two short, discontinuous segments of the FeLV genome.

The FeLV helper virus contains three genes (designated *gag*, *pol*, and *env* in the canonical order 5'-3') which code for a precursor of the internal structural proteins, reverse transcriptase, and the virion envelope glycoproteins, respectively (reviewed in 3). Based on comparative mapping, heteroduplexing, and DNA sequencing data obtained with Moloney murine leukemia virus (MuLV) and MSV (12; Vande Woude et al., in press; unpublished data), we estimate that the *gag* gene begins at ~ 1.0 kbp on the FeLV proviral DNA map. This is based on measurements of the complexity of the 5' ETR sequence (~ 0.75 kbp) and observations in the MSV (MuLV) system which show that an additional leader sequence of at least ~ 0.20 kbp precedes the first initiator codon at the 5' end of the *gag* gene. From the molecular weights of the known FeLV gene products, we would approximate the positions of *gag*, *pol*, and *env* genes at 1.0 to 3.2 kbp, 3.2 to 5.5 kbp, and 5.5 to 7.5 kbp, respectively, on the FeLV map. The remaining 1,000 bases in FeLV DNA would then include ~ 0.85 kbp derived from the extreme 3' end of the FeLV genome (the *c* region) and a terminal 140-base sequence derived from the extreme 5' end of viral RNA. Although these assignments

represent our best estimate of the complexity and topological location of the different FeLV genes, we emphasize that the analysis is largely inferential.

The FeLV *gag* gene encodes a protein of $\sim 65,000$ molecular weight which is processed into four smaller polypeptides, the order of which in the precursor is $\text{NH}_2\text{-p15-p12-p30-p10-COOH}$ (25). A portion of the FeLV *gag* sequence (0.9 kb) has been retained in ST FeSV and is expected to code for NH_2 -terminal *gag* gene products. Indeed, cells nonproductively transformed by the ST strain produce p15, p12, some p30, but no p10 antigens (25, 30). The p15 and p12 antigens encoded by FeSV are synthesized as part of a high-molecular-weight *gag-x* polyprotein (25, 30, 36, 37, 43). In the ST strain, the apparent molecular weight of this protein is $\sim 78,000$ (S. Ruscetti, L. Turek, and C. J. Sherr, unpublished data), which is expected to contain a 51,000 " χ "-moiety of non-*gag* origin. The *gag-x* polyprotein can be synthesized in a cell-free system by using full-length FeSV RNA as the message (R. Callahan, S. Ruscetti, and C. J. Sherr, unpublished data), indicating that sequences encoding χ are adjacent to *gag* sequences in FeSV RNA. We therefore conclude that the latter sequences would be ~ 1.4 kb in length and represent sequences specific to FeSV.

Of particular interest are data obtained by restriction enzyme and heteroduplex analyses of cloned DNAs which show that sequences just to the right of the FeSV *src* gene are derived from

an internal segment of the FeLV genome assigned between 5.8 and 6.4 kbp on the FeLV map. This segment would appear to correspond to a short region near the 5' end of the FeLV *env* gene. Thus, the order of gene sequences within ST FeSV would be 5'-*gag-src-env-c-region-3'* where only a portion of the *gag* and *env* regions are represented. It should be emphasized that our measurements of the size of the *gag-x* polyprotein and of the complexity of *gag* and *src* sequences are not sufficiently precise to exclude the possibility that sequences encoding the χ -moiety terminate within the *env* region. Thus, the carboxyterminal portion of the *gag-x* polyprotein may not solely be derived from sequences unique to the sarcoma virus.

Comparative heteroduplexing studies between the cloned DNAs of ST FeSV and the m_1 strain of Moloney MSV show that two distinct regions of homology can be identified in these different mammalian sarcoma viruses. The first such segment corresponds to sequences at the extreme 5' end of viral RNA which appear to include the 5'- "strong-stop" region (20), as well as the adjacent leader sequence preceding the *gag* gene. The second region of homology includes a 0.3-kbp segment located just to the right of the FeSV *src* sequence and just to the left of the *src* sequence of m_1 MSV. Heteroduplexing and R-looping studies performed with m_1 MSV and Moloney MuLV indicate that these MSV sequences are also derived from a genome segment located near the 5' end of the MuLV *env* gene (11, 12; Vande Woude et al., in press). Thus, unlike FeSV, the order of genes in m_1 MSV is 5'-*gag-env-src-c-region-3'* (12; Vande Woude et al., in press). The m_1 MSV genome codes for a 60,000-dalton protein (p60) which is primarily a *gag* gene product; MSV p60 lacks p10 antigens but contains unique carboxyterminal peptides not found in the MuLV *gag* precursor (29, 50). The MSV *src* gene product has not yet been identified but appears to be synthesized from a different mRNA species in the MSV 124 isolate (11). Since an RNA splicing recipient site is located near the 5' end of the *env* sequence in nondefective helper viruses (10, 21, 32, 42, 52), such a sequence has most likely been conserved in the formation of the m_1 MSV genome. The different topological locations of 5' *env*-derived segments in m_1 MSV and ST FeSV appear, then, to determine whether the *src* product is synthesized as a *gag-x* polyprotein.

The order and complexity of different gene sequences in ST FeSV are most analogous to those observed in the defective leukemia viruses of chickens, MC-29, MH-2, and CM-II. Like FeSV, each of these viruses synthesizes *gag-x* polyproteins (7, 8, 28), and each contains ho-

mologous, short segments of *env*-derived sequences situated just to the 3' end of *onc* elements (8, 24, 28, 48). The retention of such sequences in acutely transforming viruses of both mammals and birds might reflect a property unrelated to the coding capacity of the virus (such as a propensity to transduce cellular *onc* elements within an *env* sequence) or could imply that these sequences are necessary for transformation. To date, there is no evidence that sequences representing the 3' one-third of FeSV or defective leukemia virus genomes are represented in spliced mRNA molecules or code for discrete protein products. We therefore consider the alternative possibility that the conserved portions of "*env*" genes encode "signal peptides" which confer the property of membrane binding. Such peptides could be generally represented near the aminotermini of leukemia viral envelope glycoproteins but might also appear at the aminoterminus of the MSV *src* product and at the carboxytermini of *gag-x* polyproteins. This hypothesis, although speculative, is consistent with observations showing that *gag-x* polyproteins are associated with the plasma membranes of transformed cells (37, 39, 53, 54). The ability to identify putative "transformation-specific proteins" and to sequence those portions of the DNA proviruses which encode them now provides the first opportunity to approach these questions directly.

ACKNOWLEDGMENTS

We gratefully thank L. Donner and L. Turek for helpful discussions throughout the progress of this work; J. Kvedar, T. Shaffer, and P. Schiop-Stansley for their expert assistance with the experiments; and D. Little for help in the preparation of the manuscript.

These studies were supported in part by the Viral Oncology Program of the National Cancer Institute.

LITERATURE CITED

1. Ando, T. 1966. A nuclease specific for heat-denatured DNA isolated from a product of *Aspergillus oryzae*. *Biochim. Biophys. Acta* 114:158-168.
2. Baltimore, D. 1970. Viral RNA-dependent DNA polymerase. *Nature (London)* 226:1209-1211.
3. Baltimore, D. 1974. Tumor viruses: 1974. Cold Spring Harbor Symp. Quant. Biol. 39:1187-1200.
4. Baltimore, D., E. Gilboa, E. Rothenberg, and F. Yoshimura. 1978. Production of a discrete infectious, double-stranded DNA by reverse transcription of virions of Moloney murine leukemia virus. Cold Spring Harbor Symp. Quant. Biol. 43:869-874.
5. Benveniste, R. E., R. Heinemann, G. L. Wilson, R. Callahan, and G. J. Todaro. 1974. Detection of baboon type C viral sequences in various primate tissues by molecular hybridization. *J. Virol.* 14:56-67.
6. Benz, E. W., and D. Dino. 1979. Moloney murine sarcoma virions synthesize full genome-length double-stranded DNA *in vitro*. *Proc. Natl. Acad. Sci. U.S.A.* 76:3294-3298.
7. Bister, K., M. J. Hayman, and P. K. Vogt. 1977. Defectiveness of avian myelocytomatosis virus MC29: isolation of long-term nonproducer cultures and analysis

- of virus-specific polypeptide synthesis. *Virology* **82**:431-448.
8. **Bister, K., H. Loliger, and P. H. Duesberg.** 1979. Oligoribonucleotide map and protein of CML: detection of conserved and nonconserved genetic elements in avian acute leukemia viruses CMII, MC29, and MH2. *J. Virol.* **32**:208-219.
 9. **Britten, R. J., and D. E. Kohne.** 1968. Repeated sequences in DNA. *Science* **161**:529-540.
 10. **Cordell, B., S. R. Weiss, H. E. Varmus, and J. M. Bishop.** 1978. At least 104 nucleotides are transposed from the 5' terminus of the avian sarcoma virus genome to the 5' termini of smaller viral mRNAs. *Cell* **15**:79-91.
 11. **Donoghue, D. J., P. A. Sharp, and R. A. Weinberg.** 1979. An MSV-specific subgenomic mRNA in MSV-transformed 68-124 cells. *Cell* **17**:53-64.
 12. **Donoghue, D. J., P. A. Sharp, and R. A. Weinberg.** 1979. Comparative study of different isolates of murine sarcoma virus. *J. Virol.* **32**:1015-1027.
 13. **Enquist, L. W., M. J. Madden, P. Schiop-Stansley, and G. F. Vande Woude.** 1979. Cloning of a herpes simplex type I DNA in a bacteriophage lambda vector. *Science* **203**:541-544.
 14. **Essex, M.** 1975. Horizontally and vertically transmitted oncornaviruses of cats. *Adv. Cancer Res.* **21**:175-248.
 15. **Fischinger, P. J., C. S. Blevins, and S. Nomura.** 1974. Simple, quantitative assay for both xenotropic murine leukemia and ecotropic feline leukemia viruses. *J. Virol.* **14**:177-179.
 16. **Frankel, A. E., J. H. Gilbert, K. J. Porzig, E. M. Scolnick, and S. A. Aaronson.** 1979. Nature and distribution of feline sarcoma virus nucleotide sequences. *J. Virol.* **30**:821-827.
 17. **Gardner, M. B., R. W. Rongey, P. Arnstein, J. D. Estes, P. Sarma, R. J. Huebner, and C. G. Rickard.** 1970. Experimental transmission of feline fibrosarcoma to cats and dogs. *Nature (London)* **226**:807-809.
 18. **Gilboa, E., S. Goff, A. Shields, F. Yoshimura, S. Mitra, and D. Baltimore.** 1979. *In vitro* synthesis of a 9 kilobase pair terminally redundant DNA carrying the infectivity of Moloney murine leukemia virus. *Cell* **16**:863-874.
 19. **Hager, G. L., E. H. Chang, H. W. Chan, C. F. Garon, M. A. Israel, M. A. Martin, E. M. Scolnick, and D. R. Lowy.** 1979. Molecular cloning of the Harvey sarcoma virus closed circular DNA intermediates: initial structural and biological characterization. *J. Virol.* **31**:795-809.
 20. **Haseltine, W. A., D. G. Kleid, A. Panet, E. Rothenberg, and D. Baltimore.** 1976. Ordered transcription of RNA tumor virus genomes. *J. Mol. Biol.* **106**:109-131.
 21. **Haywood, W. S.** 1977. Size and genetic content of viral RNAs in avian oncornavirus-infected cells. *J. Virol.* **24**:47-63.
 22. **Henderson, I. C., M. M. Lieber, and G. J. Todaro.** 1974. Focus formation and the generation of "non-producer" cell lines with murine and feline sarcoma viruses. *Virology* **60**:282-287.
 23. **Hsu, T. W., J. L. Sabran, G. E. Mark, R. V. Guntaka, and J. M. Taylor.** 1978. Analysis of unintegrated avian RNA tumor virus double-stranded DNA intermediates. *J. Virol.* **28**:810-818.
 24. **Hu, S. S., M. M. Lai, and P. K. Vogt.** 1979. Genome of avian myelocytomatosis virus, MC-29: analysis by heteroduplex mapping. *Proc. Natl. Acad. Sci. U.S.A.* **76**:1265-1268.
 25. **Khan, A. S., and J. R. Stephenson.** 1977. Feline leukemia virus: biochemical and immunological characterization of gag gene-coded structural proteins. *J. Virol.* **23**:599-607.
 26. **McDonnell, M. W., N. Simon, and F. W. Studier.** 1977. Analysis of restriction fragments of T7 DNA and determination of molecular weights by electrophoresis in neutral and alkaline gels. *J. Mol. Biol.* **110**:119-146.
 27. **McDonough, S. K., S. Larsen, R. S. Brodey, M. D. Stock, and W. D. Hardy Jr.** 1971. A transmissible feline fibrosarcoma of viral origin. *Cancer Res.* **31**:953-956.
 28. **Mellon, P., A. Pawson, K. Bister, G. S. Martin, and P. H. Duesberg.** 1978. Specific RNA sequences and gene products of MC29 avian acute leukemia virus. *Proc. Natl. Acad. Sci. U.S.A.* **75**:5874-5878.
 29. **Oskarsson, M. K., W. G. Robey, C. L. Harris, P. J. Fischinger, D. K. Haapala, and G. F. Vande Woude.** 1975. A p60 polypeptide in the feline leukemia virus pseudotype of Moloney sarcoma virus with murine leukemia virus p30 antigenic determinants. *Proc. Natl. Acad. Sci. U.S.A.* **72**:2380-2384.
 30. **Porzig, K. J., M. Barbacid, and S. A. Aaronson.** 1979. Biological properties and translational products of three independent isolates of feline sarcoma virus. *Virology* **92**:91-107.
 31. **Robbins, K. C., M. Barbacid, K. J. Porzig, and S. A. Aaronson.** 1979. Involvement of different exogenous feline leukemia virus subgroups in the generation of independent feline sarcoma virus isolates. *Virology* **97**:1-11.
 32. **Rothenberg, E., D. J. Donoghue, and D. Baltimore.** 1978. Analysis of a 5' leader sequence on murine leukemia virus 21S RNA: heteroduplex mapping with long reverse transcriptase products. *Cell* **13**:435-451.
 33. **Sarma, P. S., and T. Log.** 1975. Subgroup classification of feline leukemia and sarcoma viruses by viral interference and neutralization tests. *Virology* **54**:160-169.
 34. **Shank, P. R., S. H. Hughes, H. J. Kung, J. E. Majors, N. Quintrell, R. V. Guntaka, J. M. Bishop, and H. E. Varmus.** 1978. Mapping unintegrated avian sarcoma virus DNA: termini of linear DNA bear 300 nucleotides present once or twice in two species of circular DNA. *Cell* **15**:1383-1395.
 35. **Sherr, C. J., L. A. Fedele, L. Donner, and L. P. Turek.** 1979. Restriction endonuclease mapping of unintegrated proviral DNA of Snyder-Theilen feline sarcoma virus: localization of sarcoma-specific (*src*) sequences. *J. Virol.* **32**:860-875.
 36. **Sherr, C. J., A. Sen, G. J. Todaro, A. Sliski, and M. Essex.** 1978. Pseudotypes of feline sarcoma virus contain a 85,000 dalton protein with feline oncornavirus-associated cell membrane antigen (FOCMA) activity. *Proc. Natl. Acad. Sci. U.S.A.* **75**:1505-1509.
 37. **Sherr, C. J., G. J. Todaro, A. Sliski, and M. Essex.** 1978. Characterization of a feline sarcoma virus-coded antigen (FOCMA-S) by radioimmunoassay. *Proc. Natl. Acad. Sci. U.S.A.* **75**:4489-4493.
 38. **Shoyab, M., and A. Sen.** 1978. A rapid method for the purification of extrachromosomal DNA from eukaryotic cells. *J. Biol. Chem.* **253**:6654-6656.
 39. **Sliski, A., M. Essex, C. Meyer, and G. J. Todaro.** 1977. Feline oncornavirus-associated cell membrane antigen: expression in transformed nonproducer mink cells. *Science* **196**:1336-1338.
 40. **Snyder, S. P., and G. H. Theilen.** 1969. Transmissible feline fibrosarcoma. *Nature (London)* **221**:1074-1075.
 41. **Southern, E. M.** 1975. Detection of specific sequences among DNA fragments separated by gel electrophoresis. *J. Mol. Biol.* **98**:503-517.
 42. **Stacey, D. W., V. G. Allfrey, and H. Hanafusa.** 1977. Microinjection analysis of envelope glycoprotein messenger activities of avian leukosis viral RNAs. *Proc. Natl. Acad. Sci. U.S.A.* **74**:1614-1618.
 43. **Stephenson, J. R., A. S. Khan, A. H. Sliski, and M. Essex.** 1977. Feline oncornavirus-associated cell membrane antigen: evidence for an immunologically cross-reactive feline sarcoma virus-coded protein. *Proc. Natl.*

- Acad. Sci. U.S.A. 74:5608-5612.
44. **Sternberg, N., D. Tiemeier, and L. Enquist.** 1977. *In vitro* packaging of a λ Dam vector containing Eco RI fragments of E. coli and phage P1. *Gene* 1:255-280.
 45. **Temin, H. M., and S. Mizutani.** 1970. RNA-dependent DNA polymerase in virions of Rous sarcoma virus. *Nature (London)* 226:1211-1213.
 46. **Thomas, M., J. R. Cameron, and R. W. Davis.** 1974. Viable molecular hybrids of bacteriophage λ and eukaryotic DNA. *Proc. Natl. Acad. Sci. U.S.A.* 71:4579-4583.
 47. **Thomas, M., R. L. White, and R. W. Davis.** 1976. Hybridization of RNA to double-stranded DNA: formation of R-loops. *Proc. Natl. Acad. Sci. U.S.A.* 73:2295-2298.
 48. **Tsichlis, P. N., and J. M. Coffin.** 1979. Recombinations between the defective component of an acute leukemia virus and Rous associated virus O, an endogenous virus of chickens. *Proc. Natl. Acad. Sci. U.S.A.* 76:3001-3005.
 49. **Vande Woude, G. F., M. Oskarsson, L. W. Enquist, S. Nomura, M. Sullivan, and P. J. Fischinger.** 1979. The cloning of integrated Moloney sarcoma proviral DNA sequences in bacteriophage lambda. *Proc. Natl. Acad. Sci. U.S.A.* 76:4464-4468.
 50. **Vande Woude, G. F., W. G. Robey, M. K. Oskarsson, D. K. Haapala, P. J. Fischinger, R. Naso, and R. B. Arlinghaus.** 1976. Properties of Moloney sarcoma virus-specific p60 and its detection in transformed cells. *Bibl. Haematol. (Basel)* 43:125-127.
 51. **Verma, I. M.** 1978. Genome organization of RNA tumor viruses. I. *In vitro* synthesis of full genome-length single-stranded and double-stranded viral DNA transcripts. *J. Virol.* 26:615-619.
 52. **Weiss, S. R., H. E. Varmus, and J. M. Bishop.** 1977. The size and genetic composition of virus-specific RNAs in the cytoplasm of cells producing avian sarcoma-leukemia viruses. *Cell* 12:983-992.
 53. **Witte, O. N., N. Rosenberg, and D. Baltimore.** 1979. Preparation of syngeneic tumor regressor serum reactive with the unique determinants of the Abelson murine leukemia virus-encoded p120 protein at the cell surface. *J. Virol.* 31:776-784.
 54. **Witte, O. N., N. Rosenberg, M. Paskind, A. Shields, and D. Baltimore.** 1978. Identification of an Abelson murine leukemia virus-encoded protein present in transformed fibroblasts and lymphoid cells. *Proc. Natl. Acad. Sci. U.S.A.* 75:2488-2492.