

# Ion Etching of Bacteriophage $\lambda$ : Evidence That the Right End of the DNA Is Located at the Outside of the Phage DNA Mass

JAY C. BROWN\* AND WILLIAM W. NEWCOMB

*Department of Microbiology, University of Virginia School of Medicine, Charlottesville, Virginia 22908*

Received 2 June 1986/Accepted 5 August 1986

**Bacteriophage  $\lambda$  was etched in an  $\text{Ar}^+$  plasma under conditions in which the capsid and some of the DNA were eroded (by sputtering) from the particle surface. Analysis of the DNA remaining in etched phage demonstrated an enrichment in sequences derived from the left end and middle of the genome; sequences from the right end were selectively lost. The results suggest that the DNA in the mature phage is arranged with its left end toward the center and its right end toward the exterior of the overall DNA mass. Since the left end is the first to enter the phage prohead, the results are most compatible with the view that prohead filling also proceeds from the center to the exterior of the cavity. The suggested arrangement of  $\lambda$  DNA is comparable to that observed in phage T4 and is consistent with the spiral-fold model of packaged DNA.**

Recent plasma etching studies with bacteriophage T4 have provided new information about the arrangement of DNA in the mature phage head (2). The last DNA packaged into the prohead was found to be at the periphery of the overall DNA mass, while the first DNA packaged was inferred to be at the center. Such an arrangement would be expected if DNA were condensed beginning at the center of the prohead cavity and progressing toward the outside.

It is attractive to suppose that DNA will prove to be packaged in other double-stranded DNA phages (such as  $\lambda$ , P22, T7, and  $\phi$ 29) as it is in T4 (4, 14), but this need not be the case. There exist significant differences in genomic organization and virus structure among the double-stranded DNA phages, and these may underlie corresponding differences in the way DNA is packaged into the mature head. For instance, whereas T4 and P22 DNAs are packaged by a "headfull" mechanism, packaging in  $\lambda$ , P2, and other phages begins and ends at fixed points on the genetic map (14, 18). Permuted and terminally redundant genomes are characteristic of some double-stranded DNA phages (e.g., T4 and P22), while in others the DNA is identical in all individual particles (e.g.,  $\lambda$ , P2,  $\phi$ 29, and others). T4 differs from other phages in that the first DNA to enter the prohead appears to be the first ejected during infection of sensitive cells (3). It also differs from  $\lambda$  in that it contains DNA-binding internal proteins and peptides (4).

The experiments described below were undertaken to study the arrangement of DNA in bacteriophage  $\lambda$ . They were designed to determine whether DNA is arranged at random in the phage head or whether particular regions of the DNA occur systematically in particular regions of the overall DNA mass. Our experimental strategy involved the use of  $\text{Ar}^+$  etching to distinguish externally disposed from internal DNA sequences. Intact phage were etched in an  $\text{Ar}^+$  plasma under conditions designed to produce a more or less geometrically uniform erosion of the capsid and some, but not all, of the DNA. The DNA remaining after etching (which was expected to be derived from the center of the overall DNA condensate) was then analyzed to determine whether it corresponded to particular mapped restriction fragments of mature  $\lambda$  DNA.

## MATERIALS AND METHODS

**Phage growth.** All experiments were carried out with  $\lambda$ vir (the gift of A. Blasband) grown on plate cultures of *Escherichia coli* CS-109. Phage DNA was radioactively labeled by including 0.5 mCi of [ $^3\text{H}$ ]thymidine (62.5 Ci/mmol; New England Nuclear Corp., Boston, Mass.) in 120 ml of top agar. Phage were purified by two cycles of CsCl density gradient ultracentrifugation as described by Maniatis et al. (12). Electron-microscopic examination of negatively stained preparations revealed that phage particles were intact and that 96% or more had full (DNA containing) heads.

**Ion etching.**  $\text{Ar}^+$  etching was performed in a modified Polaron model E5100 sputter coater. Plasmas were developed in a cylindrical chamber 14 cm high by 15 cm wide and containing disk-shaped aluminum electrodes 14 cm in diameter and separated by 4 cm. All etching experiments were carried out at 5 mA in an atmosphere of 100% Ar at 100 mtorr (ca. 13.3 Pa). Phage to be used for DNA analysis were etched on aluminum foil (Reynolds 625) sheets (2 by 2 cm). Phage ( $10^{10}$ ) (containing 800 to 1,000 cpm of  $^3\text{H}$  label) in 5  $\mu\text{l}$  of SM buffer (0.1 M NaCl, 8 mM  $\text{MgSO}_4$ , 5 mM Tris hydrochloride [pH 7.5]) were spread evenly on a foil square (where they occupied less than a single phage monolayer) which was then washed briefly (5 s) in 0.1 M ammonium acetate and quickly frozen in liquid  $\text{N}_2$ . Phage were then lyophilized overnight and etched for various times. Direct measurement of the DNA remaining after etching was accomplished by counting the entire foil square in a toluene-based liquid scintillation fluid (Research Products International, Elk Grove Village, Ill.).

**DNA extraction, analysis, and  $^{32}\text{P}$  labeling.** DNA was extracted from etched phage by incubating foil squares (containing etched phage) for 30 min at 37°C in 1 ml of a solution containing 0.5 mg of pronase per ml, 0.5% sodium dodecyl sulfate, and 5 mM EDTA (pH 8.0). This procedure was found to solubilize 85% or more of the phage DNA, which was then purified by phenol extraction, followed by two cycles of ethanol precipitation. Purified DNA was analyzed by electrophoresis on 2% agarose gels (6 cm long; Tris-acetate [pH 8.0] buffer system), stained with 0.5  $\mu\text{g}$  of ethidium bromide per ml, and photographed by UV transillumination as described by Maniatis et al. (12).  $^{32}\text{P}$  label was

\* Corresponding author.

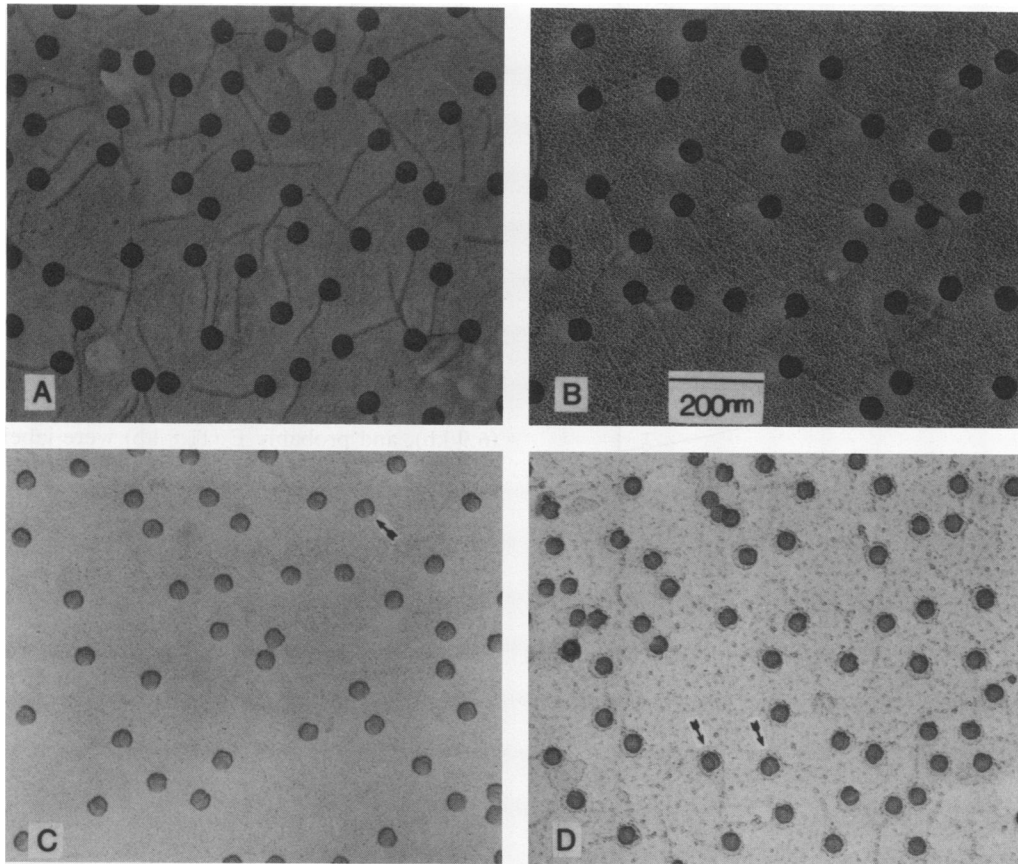

FIG. 1. Electron-microscopic analysis of  $\text{Ar}^+$ -etched  $\lambda$ . Native phage particles were critical point dried and etched on electron-microscopic grids. After being etched, phage were shadowed with Pt-Pd and photographed in a JEOL 100cx electron microscope. Micrographs show unetched phage (A) and phage etched for 10 s (B), 1 min (C), and 3 min (D). Arrows indicate particles showing the characteristic equatorial constriction (see the text).

introduced into purified DNA by nick translation by using the method of Maniatis et al. (13) with  $[\alpha\text{-}^{32}\text{P}]\text{dCTP}$  (Amersham Corp., Arlington Heights, Ill.) as the source of radioactive label. All enzymes (DNA polymerase I and DNase I), buffers, and nonradioactive deoxynucleoside triphosphates were obtained from Bethesda Research Laboratories, Gaithersburg, Md. DNA substrate (0.2 to 1.0  $\mu\text{g}$ ) was included in each 50- $\mu\text{l}$  reaction mixture, and after incubation (for 1 h at 15°C),  $^{32}\text{P}$ -labeled DNA was recovered by three cycles of ethanol precipitation. Under the conditions used, intact  $\lambda\text{vir}$  DNA was labeled to a level of  $10^8$  dpm (or more) per  $\mu\text{g}$  of DNA.

**Southern hybridization.** Southern hybridizations were performed with 1.8- $\mu\text{g}$  samples of unmethylated  $\lambda$  DNA (Sigma Chemical Co., St. Louis, Mo.) which were digested to completion with *AccI*, *BclI*, or *NruI* (GIBCO/BRL Life Technologies, Inc., Gaithersburg, Md.). Digestion products were then heated to 65°C for 5 min and separated by electrophoresis on 0.85% agarose gels which were run until the 1,444-base-pair *AccI* fragment had migrated 10 cm. After electrophoresis, gels were denatured in alkali, blotted onto nitrocellulose sheets (5 by 11 cm) with  $10\times$  SSC ( $1\times$  SSC is 0.15 M NaCl plus 0.015 M sodium citrate), and dried as described by Maniatis et al. (12). Blots were prehybridized in  $6\times$  SSC-0.5% sodium dodecyl sulfate-5 $\times$  Denhardt solution containing 100  $\mu\text{g}$  of denatured salmon sperm DNA (Sigma) per ml for 4 h at 65°C and hybridized overnight at 65°C in 5 ml of the same medium containing 0.01 M EDTA and at least

$5 \times 10^5$  dpm of denatured,  $^{32}\text{P}$ -labeled probe DNA (from etched phage). After hybridization, filters were washed for 2 h at 65°C in several changes of  $0.1\times$  SSC-0.5% sodium dodecyl sulfate, dried, and radioautographed with Kodak XAR medical X-ray film. No radioactivity was detected on filters if denatured  $\lambda$  DNA was omitted during the blotting step.

**Electron microscopy.** Phage samples to be examined in the electron microscope were adsorbed to carbon-Formvar-coated electron microscope grids, critical point dried in a Tousimis samdri 780 critical point dryer, and etched as described above on aluminum foil supports. After being etched, phage specimens were rotary shadowed with Pt-Pd and photographed at 50,000 $\times$  in a JEOL-100cx electron microscope as previously described (15).

## RESULTS

**$\text{Ar}^+$  etching.**  $\text{Ar}^+$  etching at 5 mA for 1 to 5 min was found to produce the type of uniform and partial erosion required for our studies. Electron-microscopic analysis (Fig. 1) of phage etched under these conditions revealed that the head remained recognizably intact as its diameter was progressively diminished. As in the case of T4, erosion appeared to be directionally uniform (2). The reduction in diameter amounted to approximately 16% after 1 min and 30% after 3 min of etching (Fig. 1C and D, respectively). Phage tails were visibly damaged after 10 s of etching (Fig. 1B) and

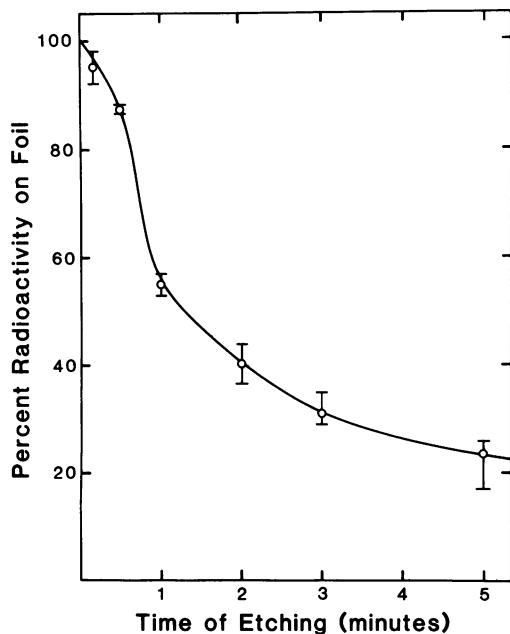

FIG. 2. Effect of  $\text{Ar}^+$  etching on the amount of DNA present in the  $\lambda$  head. Phage whose DNA had been radioactively labeled by growth in the presence of  $[^3\text{H}]$ thymidine were lyophilized on aluminum foil supports, etched for the indicated times, and counted in a liquid scintillation counter. Points show the average and extreme amounts of radioactivity remaining in at least six identical determinations.

completely lost after 30 to 60 s (Fig. 1C). A distinct constriction or cleft was observed in a significant proportion of phage particles etched for 1 min or more (arrows in Fig. 1C and D). The structural basis for the cleft is not known, although it resembles a similar constriction observed in phage T4 (2).

The amount of DNA remaining in etched phage was determined with  $\lambda$  preparations whose DNA had been radioactively labeled by growth in the presence of  $[^3\text{H}]$ thymidine. Such phage were etched on aluminum foil targets, and the amount of DNA remaining was determined by counting the entire foil square. The results (Fig. 2) demonstrated that DNA was lost (by sputtering) rapidly during the first 1 to 2 min of etching and more slowly thereafter. The results are in qualitative agreement with the rate of erosion expected on the basis of the morphological observations shown in Fig. 1.

The physical state of DNA isolated from etched phage was analyzed by agarose gel electrophoresis. Short periods of etching that resulted in little DNA loss were nevertheless found to produce significant damage to  $\lambda$  DNA. After 30 s of etching, for instance (Fig. 3, lane 3), no full-length DNA molecules remained. Fragments were found in a very broad distribution from approximately 20,000 to 150 base pairs, with evidence of concentrations at the upper and lower ends of the distribution. Longer periods of etching (Fig. 3, lanes 4 and 5) produced a net loss of DNA and a decrease in average fragment length. No evidence of a discrete or preferred fragment size was observed after any of the etching periods examined. Etching for periods of approximately 5 min or longer resulted in the loss of all detectable DNA.

**DNA analysis by Southern hybridization.** The genomic origin of DNA remaining in etched phage was analyzed by Southern hybridization. DNA was first isolated from etched phage (see Materials and Methods) and labeled *in vitro* with  $^{32}\text{P}$  by nick translation (13). Labeled DNA was then used to

probe Southern blots of  $\lambda$  restriction digests. It was expected that regions of the genome lost during the etching process would not be represented in the  $^{32}\text{P}$ -labeled probe and therefore would not label corresponding restriction fragments in the blot.

Southern hybridization was carried out with whole  $\lambda$  DNA digested separately with *AccI*, *BclI*, and *NruI*. The products of restriction enzyme digestion (Fig. 4) were separated by agarose gel electrophoresis and blotted onto nitrocellulose as described in Materials and Methods. Hybridizations were performed at  $65^\circ\text{C}$  with  $^{32}\text{P}$ -labeled probe DNA derived from phage etched for various times and (as a control) from unetched phage. The results (Fig. 5) demonstrated that etching was correlated with a nonuniform labeling of fragments in all three restriction digests. For instance, in the case of the *AccI* digest, fragments J (5.6 kilobases [kb]), H (6.9 kb), and probably E (11.8 kb) were labeled to a lesser extent by the probe prepared from etched phage than by the control probe. Other *AccI* fragments were labeled to a similar extent by the two probes. Likewise, fragments F (6.3 kb) and G (2.7 kb) of the *BclI* digest and fragments F (6.7 kb), E (9.4 kb), and C (3.7 kb) of the *NruI* digest were more weakly labeled by the etched probe than by the unetched one (Fig. 5).

As a control experiment, blots that had been hybridized with  $[^{32}\text{P}]$ DNA prepared from etched phage were reprobated with  $[^{32}\text{P}]$ DNA derived from unetched phage. Radioauto-

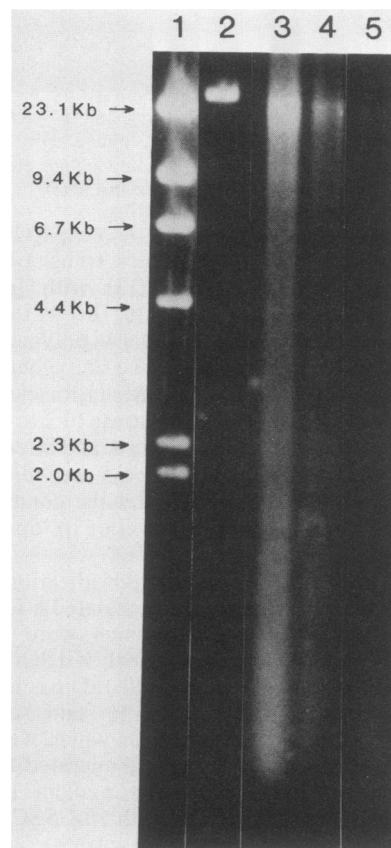

FIG. 3. Agarose gel electrophoresis of DNA isolated from  $\text{Ar}^+$ -etched  $\lambda$ . DNA was prepared from  $2 \times 10^{10}$  phage unetched (lane 2) or etched for 30 s (lane 3), 1 min (lane 4), or 3 min (lane 5). Lane 1 shows DNA size markers obtained from a *HindIII* digest of  $\lambda$  DNA (GIBCO/BRL).

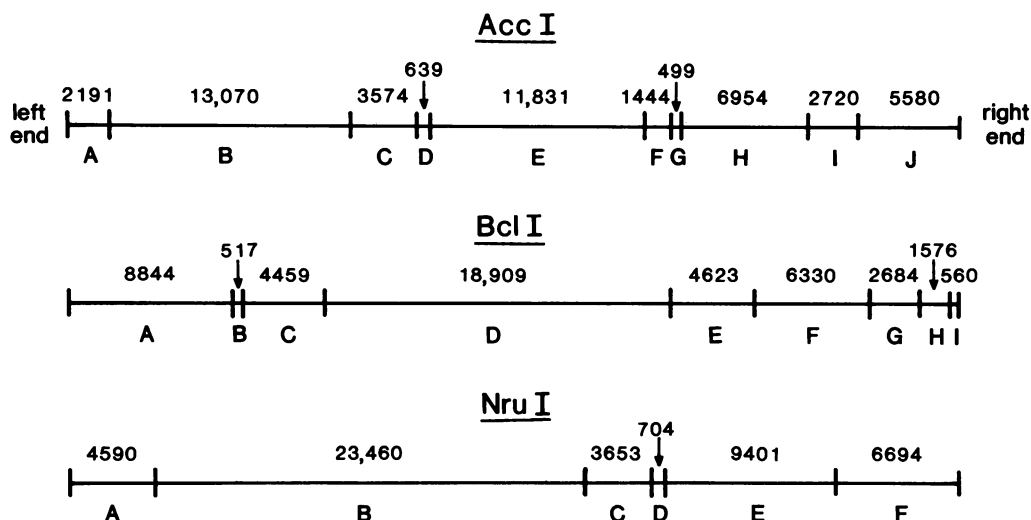

FIG. 4. Restriction maps of  $\lambda$  DNA for *AccI*, *BclI*, and *NruI*. Maps show digestion sites expected on the basis of the published sequence for  $\lambda$ clind1ts857Sam7 DNA (16). Numbers indicate the sizes of the restriction fragments in base pairs.

graphs showed that the pattern of labeling observed after reprobing matched that seen when comparable blots were hybridized with the control probe only (data not shown).

**DISCUSSION**

Inspection of the restriction maps shown in Fig. 4 reveals a common feature of DNA sequences underrepresented in etched phage. All are derived from the right end or from the right end to approximately the middle of mature  $\lambda$  DNA. This result suggests that there exists at least some degree of order in the way DNA is arranged in the phage head. More particularly, compared to the remainder of the DNA, the

DNA originating from the right end of the genome is found systematically nearer the surface of the overall DNA mass. The suggested arrangement of  $\lambda$  DNA is therefore comparable to that observed (2) in phage T4 because in both cases the last DNA packaged into the prohead in vivo (the right end in the case of  $\lambda$  [7, 8, 17, 19]) is found at the outside of the mature DNA condensate.

The Southern hybridization results shown in Fig. 5 illustrate the point that we rarely observed restriction fragments, even those derived from the extreme right end of the genome, that were completely unlabeled by DNA from etched phage. Reduced, but not negligible, labeling of right-

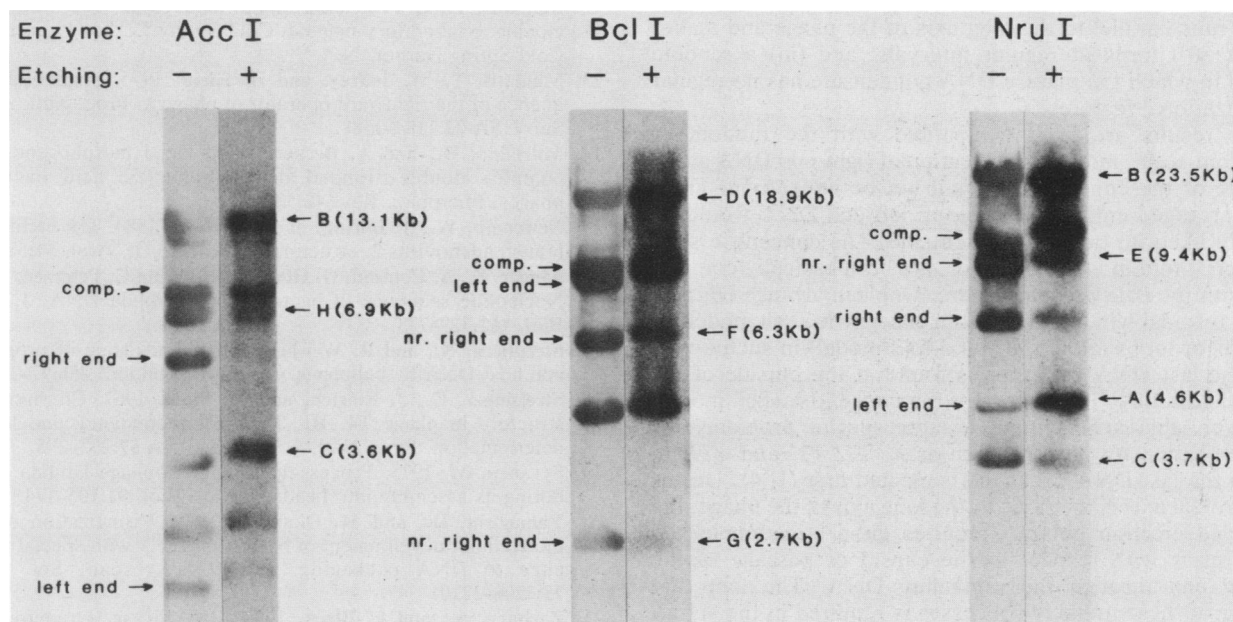

FIG. 5. Radioautograph of Southern hybridization experiments performed with  $\lambda$  restriction digests and DNAs prepared from etched and unetched phage. Probe DNAs were prepared by isolating DNA from etched (*AccI*, 5 min; *BclI* and *NruI*, 1 min) or unetched phage and labeling it with  $^{32}\text{P}$  by nick translation. They were used to hybridize blots of  $\lambda$  DNA that had been digested with the indicated restriction endonucleases. Hybridization and radioautography were performed as described in Materials and Methods. Selected restriction fragments are indicated by letter and size (in kilobases). At the left of each blot are shown the positions of the two end fragments and also the composite (comp.) fragment produced when the left and right ends are joined at their cohesive sites; nr., near. Other restriction fragments can be identified from the maps shown in Fig. 4.

end fragments was the rule. For instance, fragment F from the *NruI* digest, fragment G from the *BclI* digest, and fragment H from the *AccI* digest are all derived from the right end or near the right end of the genome and were all labeled to a reduced, but not negligible, extent. We believe that this is due to the fact that the phage head was in contact with its aluminum foil support during the etching process. Contact is expected to shield a small patch of external DNA from erosion so some should be represented in DNA prepared from etched phage. This DNA would result in a reduced but still detectable level of hybridization to corresponding restriction fragments.

The results presented here raise a significant expectation about the way DNA is condensed into the  $\lambda$  prohead *in vivo*. Since the left end of the genome is the first to enter the prohead (7, 8, 17, 19) and since it is also found protected at the center of the mature DNA mass, one expects that the prohead is most likely to fill beginning at the center and progressing toward the outside of the cavity. The last DNA packaged (the right end in the case of  $\lambda$ ) would then be found at the outside of the DNA condensate. This expected polarity of packaging (i.e., inside to outside) is consistent with electron-microscopic images of partially filled  $\lambda$  heads. Such structures, observed in infected cells by thin sectioning (11) or osmotic lysis (20), show DNA condensed at the center of incompletely filled  $\lambda$  particles. Similar images are found in T4-infected *E. coli* (21) and in *Salmonella typhimurium* cells infected with phage P22 (10).

The results reported above have important implications for the way DNA is arranged in the mature phage head. We consider that there exist three general models for the organization of phage DNA: (i) the concentric shell, solenoid, or spool model in which DNA makes toroidal windings about an axis that may be coincident with (5, 9) or perpendicular to (6) the long axis of the phage; (ii) the spiral-fold (2) and related (P. Serwer, *J. Mol. Biol.*, in press) models in which DNA runs parallel to the long axis of the phage and makes tight (180°) turns at regular intervals; and (iii) a random model in which the mature DNA condensate has no regular organizational features.

Our results are least compatible with the random or "random-stuff" model. The location of right-end DNA at the outside of the condensate would not be expected if DNA were arranged entirely at random; left-end DNA would be equally likely to occur at the outside. The concentric shell and spiral-fold models, however, are both basically compatible with the data presented here. One can arrange DNA in either toroidal windings (as in the concentric shell model) or in folds or loops (as in the spiral-fold model) in such a way that the last DNA packaged is found at the outside of the overall structure. In the case of the concentric shell model, however, this arrangement creates special problems for DNA ejection by phages, such as  $\lambda$ , T7, T1, and  $\phi$ 29, in which the last DNA packaged is ejected first (1, 4). Unless the toroidal axis is the same as the long axis of the phage, the observed ejection polarity requires either rotation of the DNA mass with respect to the capsid or passage of the exiting end through the remaining DNA. The fact that neither of these unlikely processes is required in the spiral-fold model provides a basis for favoring it at the present time.

#### ACKNOWLEDGMENTS

We thank W. Studier for an important suggestion about experimental design, M. Smith and members of his research group for help with the molecular biology, J. Boring for advice about ion etching methodology, and L. Black for a careful reading of the manuscript.

This work was supported by Public Health Service grant GM34036 from the National Institutes of Health.

#### LITERATURE CITED

1. Bjornsti, M.-A., B. E. Reilly, and D. L. Anderson. 1983. Morphogenesis of bacteriophage  $\phi$ 29 of *Bacillus subtilis*: oriented and quantized *in vitro* packaging of DNA protein gp3. *J. Virol.* 45:383-396.
2. Black, L., W. Newcomb, J. Boring, and J. Brown. 1985. Ion etching of bacteriophage T4: support for a spiral-fold model of packaged DNA. *Proc. Natl. Acad. Sci. USA* 82:7960-7964.
3. Black, L., and D. Silverman. 1978. Model for DNA packaging into bacteriophage T4 heads. *J. Virol.* 28:643-655.
4. Earnshaw, W., and S. Casjens. 1980. DNA packaging by the double-stranded DNA bacteriophages. *Cell* 21:319-331.
5. Earnshaw, W., and S. Harrison. 1977. DNA arrangement in isometric phage heads. *Nature (London)* 268:598-602.
6. Earnshaw, W., J. King, S. Harrison, and F. Eiserling. 1978. The structural organization of DNA packaged within the heads of T4 wild-type, isometric and giant bacteriophages. *Cell* 14:559-568.
7. Emmons, S. 1974. Bacteriophage lambda derivatives carrying two copies of the cohesive end site. *J. Mol. Biol.* 83:511-525.
8. Feiss, M., and A. Bublitz. 1975. Polarized packing of lambda chromosomes. *J. Mol. Biol.* 94:583-594.
9. Harrison, S. 1983. Packaging DNA into bacteriophage heads: a model. *J. Mol. Biol.* 171:577-580.
10. Lenk, E., S. Casjens, J. Weeks, and J. King. 1975. Intracellular visualization of precursor capsids in phage P22 mutant infected cells. *Virology* 68:182-199.
11. Lickfeld, K., B. Menge, B. Hohn, and T. Hohn. 1976. Morphogenesis of bacteriophage lambda: electron microscopy of thin sections. *J. Mol. Biol.* 103:299-318.
12. Maniatis, T., E. F. Fritsch, and J. Sambrook. 1982. Molecular cloning: a laboratory manual. Cold Spring Harbor Laboratory, Cold Spring Harbor, N.Y.
13. Maniatis, T., A. Jeffrey, and D. Kleid. 1975. Nucleotide sequence of the rightward operator of phage  $\lambda$ . *Proc. Natl. Acad. Sci. USA* 72:1184-1188.
14. Murialdo, H., and A. Becker. 1978. Head morphogenesis of complex double-stranded deoxyribonucleic acid bacteriophages. *Microbiol. Rev.* 42:529-576.
15. Newcomb, W., J. Boring, and J. Brown. 1984. Ion etching of human adenovirus 2: structure of the core. *J. Virol.* 51:52-56.
16. Sanger, F., A. Coulson, G. Hong, D. Hill, and G. Petersen. 1982. Nucleotide sequence of bacteriophage lambda DNA. *J. Mol. Biol.* 162:729-773.
17. Sternberg, N., and R. Weisberg. 1975. Packaging of prophage and host DNA by coliphage  $\lambda$ . *Nature (London)* 256:97-103.
18. Streisinger, G., J. Emrich, and M. Stahl. 1967. Chromosome structure in phage T4. III. Terminal redundancy and length determination. *Proc. Natl. Acad. Sci. USA* 57:292-295.
19. Syvanen, M. 1975. Processing of bacteriophage lambda DNA during its assembly into heads. *J. Mol. Biol.* 91:165-174.
20. Yamagishi, H., and M. Okamoto. 1978. Visualization of the intracellular development of bacteriophage  $\lambda$  with special reference to DNA packaging. *Proc. Natl. Acad. Sci. USA* 75:3206-3210.
21. Zachary, A., and L. Black. 1981. DNA ligase is required for encapsidation of bacteriophage T4 DNA. *J. Mol. Biol.* 149:641-658.