

# Herpes Simplex Virus Type 1 Latency-Associated Transcription Unit Promotes Anatomical Site-Dependent Establishment and Reactivation from Latency

N. M. SAWTELL AND R. L. THOMPSON\*

*Department of Molecular Genetics, Biochemistry, and Microbiology, ML524, University of Cincinnati Medical Center, 231 Bethesda Avenue, Cincinnati, Ohio 45267-0524*

Received 24 June 1991/Accepted 13 January 1992

Defined herpes simplex virus type 1 (HSV-1) mutants KOS/1 and KOS/62 (positive and negative, respectively, for latency-associated transcripts [LATs]) express the *Escherichia coli*  $\beta$ -galactosidase ( $\beta$ -Gal) gene during latency. These mutants were employed to assess the functions of the latency-associated transcription unit on establishment and maintenance of and reactivation from the latent state. It was found that in the trigeminal ganglia, the frequencies of hyperthermia-induced reactivation of KOS/62 and an additional LATs<sup>-</sup> mutant (KOS/29) were reduced by at least 80%. Quantification of latently infected neurons expressing the  $\beta$ -Gal gene revealed that the LATs<sup>-</sup> mutant KOS/62 established ~80% fewer latent infections in the trigeminal ganglia than did KOS/1 (LATs<sup>+</sup>). This reduction in establishment which is evident in the trigeminal ganglia could account for the reduced frequency of reactivation from this site. In striking contrast, both LATs<sup>-</sup> mutants reactivated with wild-type frequencies from lumbosacral ganglia. Quantification of  $\beta$ -Gal-positive neurons at this site revealed that KOS/62 established as many as or more latent infections than the LATs<sup>+</sup> virus, KOS/1. Colocalization of HSV antigen and  $\beta$ -Gal suggested that the decreased establishment by LATs<sup>-</sup> mutants in trigeminal ganglia was the result of inefficient viral shutoff. Thus, one function of the HSV-1 LATs transcription unit is to promote the establishment of latency in trigeminal but not lumbosacral ganglia. Such a function may be relevant to understanding the distinct clinical recurrent disease patterns of HSV-1 and HSV-2.

It has been well documented that the latency-associated transcription unit is the single region of the herpes simplex virus (HSV) genome which produces a detectable RNA during latency (4-6, 20, 26, 33, 36, 38, 40, 44, 45). The precise functional significance of transcriptional activity from this region in the establishment, maintenance, and reactivation phases of latent infection is still unclear. Data generated from studies utilizing various LATs<sup>-</sup> mutants in animal model systems have demonstrated that the LATs transcription unit is not an absolute requirement for any of these aspects of latency (15, 17, 22, 27, 35, 37), with the possible exception of induced reactivation in vivo (14). In the study described in reference 14, an LATs<sup>-</sup> mutant reactivated significantly less frequently by induction via iontophoresis of epinephrine in the rabbit eye model, although spontaneous virus shedding and reactivation in cocultivated ganglia in vitro were not affected (14). Additionally, the finding reported by several investigators that LATs<sup>-</sup> mutants reactivate with delayed kinetics in cocultivation studies has been taken as evidence for a reactivation function of LATs (22, 37). However, a clear interpretation of this finding is difficult since others have reported normal reactivation kinetics in this system with LATs mutants (2, 16, 17, 35).

A recent study has demonstrated that the major 2-kb transcript from the LATs region is actually a stable intron which is antisense to the immediate-early transcription factor ICP0 and that the intron can function to down regulate ICP0 production in transient assays (10). These findings suggest a possible role in establishment of latency. While the

LATs transcript (7, 19, 46, 47) and intron have also been detected during lytic infection of cultured cells, no effect of these low levels of the intron on ICP0 expression could be detected (7). The LATs promoter has been shown to contain neuron-specific promoter elements (1, 7, 47), and thus an increased level of the LATs intron could result in the down regulation of ICP0 in this cell type during the establishment of latency.

Because the HSV genome cannot be detected in situ in latently infected tissues, only hybridization methods on DNA extracted from ganglia have been employed to quantitatively evaluate establishment by LATs<sup>-</sup> mutants (14, 22, 35). From those studies, it was concluded that LATs<sup>-</sup> viruses established an equivalent amount of latency. However, the methods are not sensitive enough to detect HSV sequences in all ganglia known to be latently infected (14). Thus, to date, the method used to estimate latency established by LATs<sup>-</sup> mutants must be considered semiquantitative and inadequate for quantitation of the number of latently infected neurons.

The availability of LATs<sup>+</sup> and LATs<sup>-</sup> mutants in which the LATs promoter drives the *Escherichia coli*  $\beta$ -galactosidase ( $\beta$ -Gal) gene has allowed the direct comparison of the relative number of latent infections established by these mutants. In addition, development of the hyperthermia induction procedure (34a) has provided a system with which to examine the induced reactivation frequencies of these mutants in both trigeminal and lumbosacral ganglia in vivo in the absence of spontaneous reactivation events. The phenotypes of LATs<sup>-</sup> viruses were dramatically different depending on the anatomical site of latency. That is, the induced reactivation frequency of the LATs<sup>-</sup> mutants from trigeminal ganglia was reduced by nearly an order of magnitude.

\* Corresponding author.

Surprisingly, the induced reactivation frequency of the LATs<sup>-</sup> mutants from lumbosacral ganglia was indistinguishable from that of the wild type. This is the first report to demonstrate a phenotype for the LATs transcription unit dependent on the anatomical location of latency.

Quantitative analysis of establishment function demonstrated that the LATs<sup>-</sup> mutant KOS/62 established latent infection in 87% fewer trigeminal ganglionic neurons than did KOS/1 (LATs<sup>+</sup>), a likely explanation for the reduced reactivation frequency of KOS/62 from this site. Less than 15% of the KOS/1  $\beta$ -Gal-positive neurons contained detectable HSV antigen 3 to 4 days postinfection (p.i.). However, HSV antigen was detected in the majority of the  $\beta$ -Gal-expressing neurons infected with KOS/62, suggesting that the failure to establish latency was the result of inefficient viral shutoff. Our findings demonstrate that the LATs play a role in promoting efficient establishment in trigeminal ganglionic neurons and that loss of this function is not manifested in lumbosacral ganglia.

### MATERIALS AND METHODS

**Construction of viral mutants.** The three mutants used in this study, KOS/1, KOS/62, and KOS/29 (kindly provided by L. T. Feldman), were constructed from the parental strain KOS(M). KOS/29 is an LATs promoter mutant which has a 200-bp *Pst*I fragment (118,659 to 118,863 bp) deleted in the internal long repeat and in the equivalent position in the terminal long repeat (8). This deletion removes the CREB binding site (23), the TATA, and the transcriptional start site (8). The virus produces no detectable LATs (8). KOS/62 is an LAT<sup>-</sup> mutant in which HSV type 1 (HSV-1) sequences from the *Sac*II site at 118,842 bp to the *Hpa*I site at 120,466 bp of the internal long repeat and the corresponding region of the terminal long repeat were deleted and replaced with the *E. coli*  $\beta$ -Gal gene. Both copies of the LATs are disrupted in this virus (reference 11 and this report). Thus, the LATs promoter drives  $\beta$ -Gal in this virus. In KOS/1, a large region of the LATs promoter was placed in front of the  $\beta$ -Gal gene and inserted into the *Eco*RV site at 97,646 bp in the glycoprotein C locus. This resulted in the disruption of glycoprotein C and the expression of  $\beta$ -Gal during latency in an LATs<sup>+</sup> virus (12). The genomic structures of these viruses are shown schematically in Fig. 1. All restriction enzyme sites are referred to as the corresponding positions in the published HSV-1 sequence of strain 17 syn<sup>+</sup> (for a review, see reference 24).

**Southern blot analysis of viral genomic structures.** In order to confirm that the virus reactivating in the cultures had the expected genomic structure, total infected cell DNA was isolated, digested with various restriction endonucleases according to the manufacturers' (Bethesda Research Laboratories, Promega, and New England Biolabs) recommendations, electrophoresed in agarose gels, transferred to nitrocellulose, and probed with various nick translated <sup>32</sup>P-labeled probes as described previously (3, 9).

**Quantitative PCR detection of HSV DNA present in latently infected ganglia.** Quantitative polymerase chain reaction (PCR) was carried out precisely as previously described except that both trigeminal ganglia from each mouse were pooled for DNA extraction (18). Briefly, mice were infected as described above, and DNA was extracted from the ganglia at 30 days p.i. Tissues were disrupted in 20 mM Tris (pH 7.5)–200 mM EDTA (pH 8.0) and 1.0% sodium dodecyl sulfate and incubated at 50°C with 100  $\mu$ g of proteinase K (Sigma) per ml overnight. Samples were extracted with

phenol-chloroform (1 $\times$ ) and chloroform (1 $\times$ ) and precipitated with ethanol in the presence of 0.3 M sodium acetate. Samples were hydrated in 100  $\mu$ l of 10 mM Tris (pH 8.0)–1 mM EDTA (TE) and incubated with 100  $\mu$ g of RNase A (Sigma) at 37°C for 2 h, incubated for an additional 2 h with proteinase K as described above, and again extracted and precipitated. After hydration, aliquots which were not used further were quantified in a Beckman model 2400 spectrophotometer. Additional aliquots were examined by gel electrophoresis to assess the size of the DNA.

Samples (100 ng) of ganglionic DNA or, as a standard, 100 ng of mouse brain DNA spiked with known concentrations of HSV DNA was mixed with 50 pmol of each of two primer pairs. One primer pair, CTTAACAGCGTCAACAGCGT and CAAAGAGGTGGCGGAGT, is specific for the HSV-1 TK gene, and the second pair of primers, AGTGTGCGGGGATGCAGT and ACGCGAGAGCCCCACGTA, is specific for a single-copy mouse gene (adipin [18]). The DNAs were reacted in a 100- $\mu$ l volume in the presence of 50 mM KCl–10 mM Tris (pH 8.4)–4.5 mM MgCl<sub>2</sub>–100  $\mu$ g of gelatin per ml–200  $\mu$ M each deoxynucleoside triphosphate–4 U of *Taq* polymerase (Bethesda Research Laboratories). PCR was performed for 30 cycles of 1 min at 94°C, 2 min at 55°C, and 3 min at 72°C, with a final extension of 7 min at 72°C. Products were electrophoresed on 12% polyacrylamide gels and transferred to nylon filters (Magnagraph; Molecular Separations Inc.) and UV cross-linked. The filters were prehybridized and hybridized exactly as described previously (18). The probe for the HSV PCR product was CAGATCTTGGTGGCGTG end labeled with T4 polynucleotide kinase (Bethesda Research Laboratories) according to the enzyme manufacturer's protocol. The probe for the mouse PCR product was end-labeled AGTCGAAGGTGTG-GTTAC. Blots were washed as described previously (18) except that additional washes at 52°C were performed. Blots were exposed to X-ray film (Kodak) for photography and exposed in a Molecular Dynamics PhosphorImager and analyzed with ImageQuant software (Molecular Dynamics) for quantification.

**Acute replication kinetics.** The kinetics of acute replication of these viruses was determined as described previously (42). In brief, 4- to 5-week-old Swiss Webster mice were bilaterally inoculated via corneal scarification with 5  $\times$  10<sup>4</sup> PFU in 10  $\mu$ l per eye. On days 1 through 7 p.i., animals ( $n$  = 3 per day for each virus) were sacrificed by lethal dose of sodium pentobarbital, and eyes and trigeminal ganglia were aseptically removed, snap frozen, and stored at -70°C. Tissues were subsequently homogenized in media, and serial 10-fold dilutions of homogenates were overlaid with media containing 0.3% human immunoglobulin G and monitored for plaque formation.

**Cocultivation.** Male Swiss Webster mice, 4 to 5 weeks old, were inoculated as described above with KOS/1, KOS/62, KOS/29, or KOS(M). At 30 days p.i., animals were sacrificed and trigeminal ganglia were removed aseptically and cocultivated as described previously (43). In later experiments, mice were inoculated bilaterally via both corneal scarification (5  $\times$  10<sup>4</sup> PFU per eye) and the snout (3  $\times$  10<sup>5</sup> PFU per 25  $\mu$ l per whisker pad) with KOS/1 or KOS/62. Cocultivation of trigeminal ganglia from animals inoculated was carried out at 90 and 140 days p.i.

**Induced reactivation in vivo.** Mice were inoculated as for cocultivation studies. In addition, groups of animals were inoculated via the footpad with 5  $\times$  10<sup>5</sup> PFU as described previously (41). Thirty days p.i., mice were subjected to the hyperthermia induction procedure as described in reference

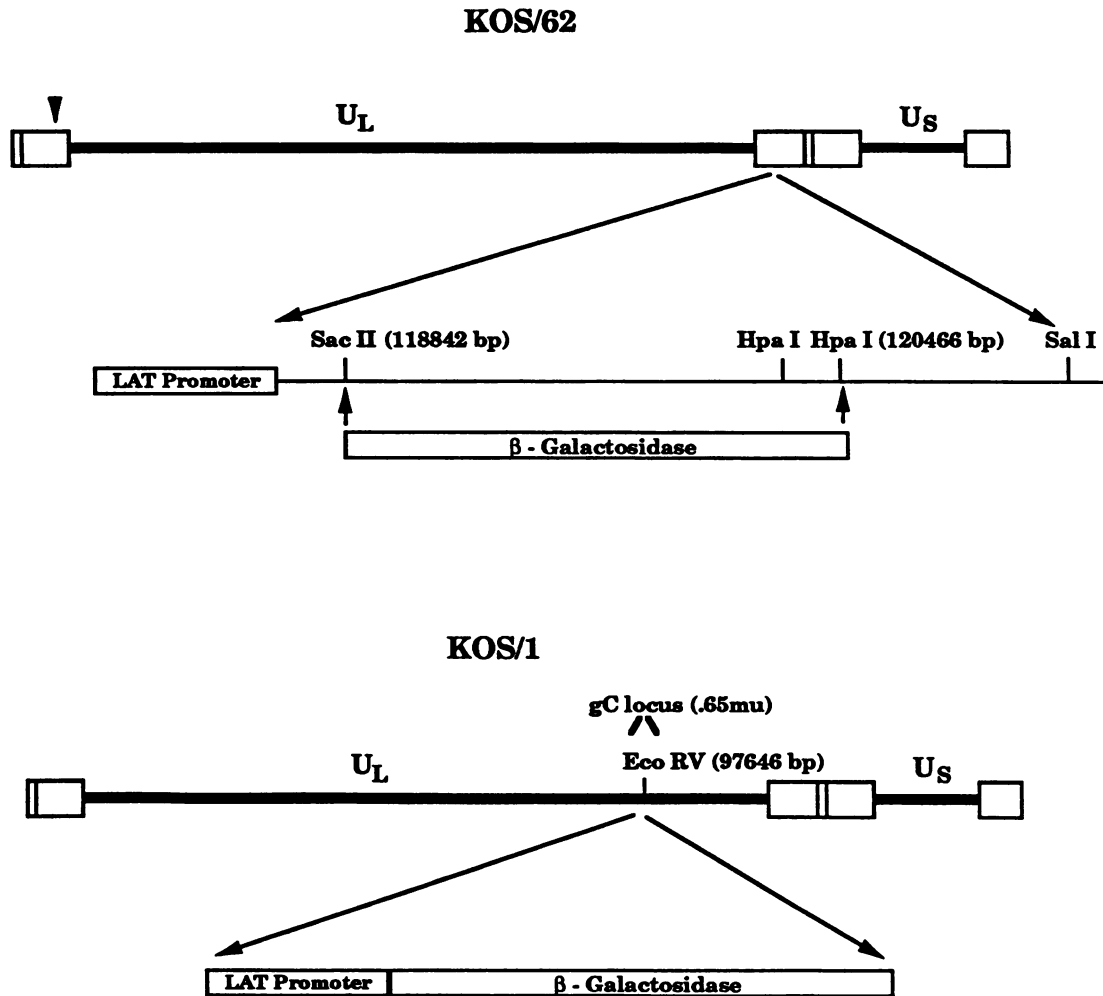

FIG. 1. Representation of genomic structures of HSV-1 LATs<sup>+</sup> (KOS/1) and LATs<sup>-</sup> (KOS/62) mutants showing the locus of *E. coli*  $\beta$ -Gal gene insertion. Details of the LATs promoter  $\beta$ -Gal construct for KOS/1 are being reported elsewhere (11). The construct for KOS/1 was inserted into the *EcoRV* site within the glycoprotein C locus of the parental strain, KOS(M). In the KOS/62 construct, the region in the internal long repeat is expanded, showing the *SacII* and *HpaI* sites. This same region is contained within the terminal long repeat (arrowhead). HSV sequences between these two restriction sites in both the internal long repeat and the terminal long repeat were deleted and replaced by the of *E. coli*  $\beta$ -Gal gene. Abbreviations: mu, map units; U<sub>L</sub>, unique long region; U<sub>S</sub>, unique short region.

34a. Twenty-four hours posttreatment, relevant ganglia were removed, homogenized, and assayed for infectious virus as described above.

**$\beta$ -Gal staining in ganglia. Evaluation of in vivo LATs promoter activity.** Male Swiss Webster mice, 4 to 5 weeks old, were inoculated with KOS/1 or KOS/62 as described above. On days 2, 3, 4, 6, 15, 30, 90, and 140 p.i., animals were anesthetized with sodium pentobarbital (50mg/kg of body weight) and perfused with a solution of 1% paraformaldehyde-0.02% glutaraldehyde-0.02% Nonidet P-40 in phosphate-buffered saline (PBS), pH 7.2. Ganglia were removed, postfixated for 15 min in the same solution, rinsed in PBS, and placed in a solution containing 5 mM of potassium ferricyanide, 5 mM of ferrocyanide, 2 mM of MgCl<sub>2</sub>, 0.02% Nonidet P-40, and 0.1  $\mu$ g of 5-bromo-4-chloro-3-indolyl- $\beta$ -galactopyranoside (X-Gal) (Fisher Biotech) per ml in PBS, pH 7.2. After an overnight incubation at 31°C, ganglia were rinsed in PBS, cleared in glycerol, and mounted between two glass slides. Assessments of the type and number of  $\beta$ -Gal-containing cells per ganglion as well as the distribution and

intensity of staining within the  $\beta$ -Gal-positive cell population were carried out independently by two observers (N.M.S. and R.L.T.).

**Colocalization of  $\beta$ -Gal and HSV antigen.** Ganglia from the preceding section from days 3, 4, and 6 p.i. were rinsed in PBS and postfixated in 4% paraformaldehyde for 3 h. The subsequent dehydration, paraffin embedding, and immunoperoxidase staining for HSV antigens were as described in reference 34a. Serial sections (10  $\mu$ m thick) were cut and systematically examined so that assessment of antigen could be made at multiple levels in each neuron.

## RESULTS

The following experiments were designed to confirm and extend previous studies examining the function of the LATs transcription unit in establishment, maintenance, and in vivo reactivation. The experimental plan was to compare the LATs<sup>-</sup> establishment/reactivation phenotype in trigeminal and lumbosacral ganglia. Induced in vivo reactivation from

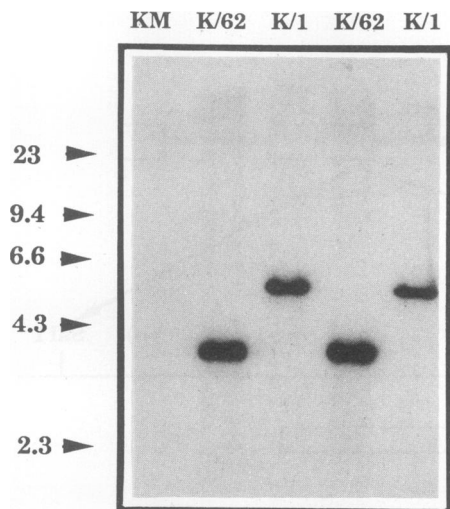

FIG. 2. Southern blot analysis of DNA isolated from rabbit skin cells infected with virus recovered from latently infected trigeminal ganglia. Shown are *SalI* digests of two independent isolates of KOS/1 (K/1) and KOS/62 (K/62) probed with  $^{32}\text{P}$ -labeled sequences specific for the *E. coli*  $\beta$ -Gal gene. The first lane contains *SalI*-digested DNA obtained from KOS(M) (KM)-infected rabbit skin cells.

both of these ganglionic sites was now possible with the hyperthermia induction procedure described in reference 34a.

Since LATs transcripts have been detected at relatively constant levels in ganglionic neurons during latency, the LATs promoter has been considered to be continually active in latently infected cells (for a review, see reference 39). Therefore, LATs<sup>+</sup> (KOS/1) and LATs<sup>-</sup> (KOS/62) mutants which contained  $\beta$ -Gal controlled by the LATs promoter were utilized so that latently infected cells could be detected histochemically and counted. The establishment efficiency of the LATs<sup>-</sup> and LATs<sup>+</sup> mutants could thus be compared directly at the cellular level. The feasibility of this approach has been demonstrated in a previous study in which the  $\beta$ -Gal gene was inserted behind the LATs promoter in an LATs<sup>-</sup> mutant (15). Although quantitative analysis of latency was not done in that study, latently infected neurons were identified histochemically as "blue cells."

**Characterization of HSV-1 LATs<sup>+</sup> and LATs<sup>-</sup> mutants.** The genomic structures of KOS/1 (LATs<sup>+</sup>) and KOS/62 (LATs<sup>-</sup>) are shown schematically in Fig. 1. These structures were confirmed by Southern blot restriction fragment length polymorphism analysis with seven different restriction enzymes and a variety of specific probes. A representative blot is shown in Fig. 2. The DNAs were cleaved with *SalI* and probed with radiolabeled sequences specific for the *E. coli*  $\beta$ -Gal gene. As expected, no hybridization was seen in the KOS(M) lane. The KOS/62 lanes each contained a labeled band at about 4.1 kb, which was in agreement with the predicted size of 4.15 kb (from a *SalI* site at the 5' end of the  $\beta$ -Gal gene to the HSV-1 *SalI* site at 120,902 bp in the internal long repeat or the corresponding site in the terminal long repeat at 5,464 bp). As described above, both copies of the LATs are disrupted in this mutant. The KOS/1 lanes contained a 4.8-kb band, which was in agreement with the predicted size of 4.832 kb from the *SalI* site in the  $\beta$ -Gal gene to the viral *SalI* site at 98,739 bp. KOS/29 has a 200-bp deletion in both copies of the LATs promoter, is LATs<sup>-</sup>,

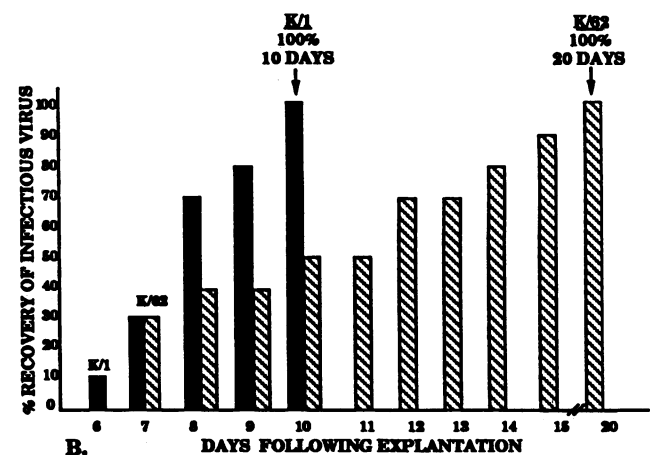
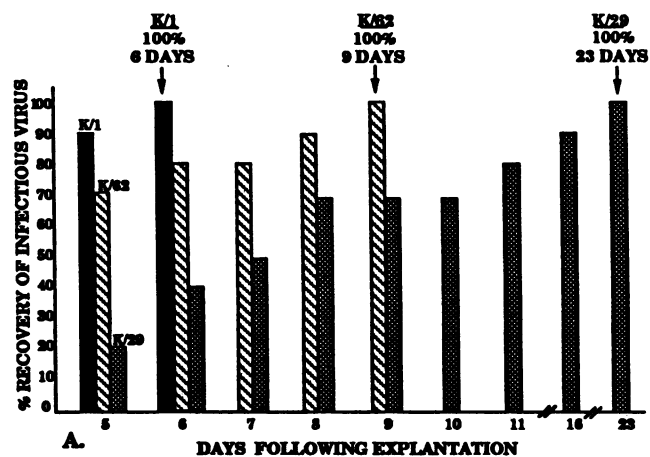

FIG. 3. Reactivation of LATs<sup>+</sup> and LATs<sup>-</sup> mutants from latently infected mouse trigeminal ganglia after explant cocultivation. The percentage of ganglia positive for virus is represented on the vertical axis. Bars represent the cumulative percentages of positive ganglia at a given time point. Ten ganglia for each virus were tested. The reactivation profiles at 30 days (A) and 140 days (B) p.i. are shown. Abbreviations: K/1, KOS/1; K/62, KOS/62; K/29, KOS/29.

and has been previously described (8). No unexpected perturbations of the genomes were detected (Fig. 2 and data not shown).

**Establishment and reactivation phenotypes of KOS(M), KOS/1, KOS/62, and KOS/29 in trigeminal ganglia.** Groups of animals were inoculated via bilateral corneal scarification with  $5 \times 10^4$  PFU of each of the three mutants, KOS/1 (LATs<sup>+</sup>), KOS/62 (LATs<sup>-</sup>), and KOS/29 (LATs<sup>-</sup>), and the parental strain, KOS(M). At 30 days p.i., trigeminal ganglia from animals inoculated with each virus were evaluated for (i) latent virus by explant cocultivation and (ii) the ability of the virus to reactivate in vivo. In addition, latency in ganglia from KOS/1- and KOS/62-infected mice was quantified by counting the cells in which active transcription from the LATs promoter was detected as  $\beta$ -Gal activity.

**Explant cocultivation.** The establishment function of KOS(M), KOS/1, KOS/62, and KOS/29 was assessed qualitatively by standard explant cocultivation 30 days p.i. Virus was recovered from trigeminal ganglia of 100% of the mice, demonstrating that all three mutant viruses could establish a latent infection and reactivate in vitro (Fig. 3A). Both LATs<sup>-</sup> viruses, however, reactivated with significantly de-

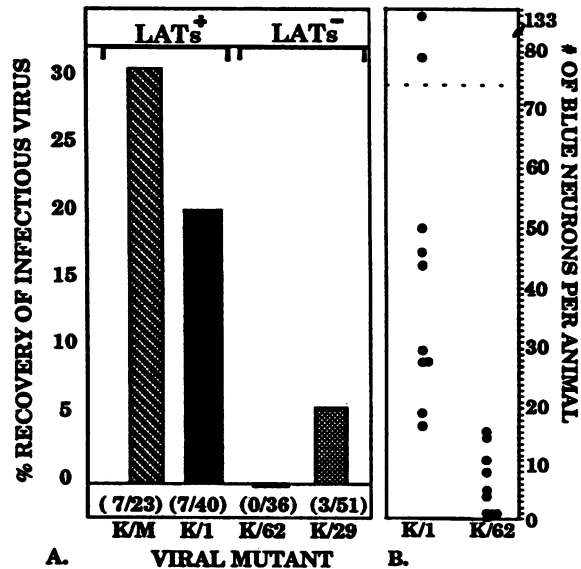

FIG. 4. Comparisons of the frequencies of in vivo reactivation (A) and the numbers of latently infected neurons (B) in trigeminal ganglia of mice latently infected with LATs<sup>+</sup> and LATs<sup>-</sup> viruses. These data are compiled from results with mice inoculated bilaterally via corneal scarification. The number of animals positive for virus of the number tested is indicated below each bar in panel A. Solid circles in panel B represent individual animals. The number of blue neurons is the total number in the two trigeminal ganglia of each animal. The dashed line is drawn at the frequency of reactivation determined in panel A. Abbreviations are same as for Fig. 3.

layed kinetics ( $P < 0.005$ ; Student's  $t$  test), a finding reported by others (22, 37). These results clearly demonstrated that 100% of the animals were latently infected by these inoculation procedures.

**Induced reactivation in vivo.** To date, the only phenotypic difference of an LATs<sup>-</sup> mutant demonstrated in vivo has been a decreased frequency of reactivation induced by iontophoresis of epinephrine in the rabbit eye model (14). To examine whether the reactivation frequency of LATs<sup>-</sup> mutants would also be reduced in mice when the hyperthermia induction procedure was used, the reactivation system described in reference 34a was employed. Latently infected mice were subjected to hyperthermia as described and were sacrificed 24 h later, and the relevant ganglia were assayed for infectious virus. A comparison of the induced reactivation frequencies of KOS(M), KOS/1, KOS/29, and KOS/62 clearly demonstrates that both LATs<sup>-</sup> mutants (KOS/29 and KOS/62) reactivated with a greatly reduced frequency, (reactivating in 6% [3 of 51] and 0% [0 of 36] of the animals, respectively, than either the parental virus [KOS(M)] (reactivating in 35% [7 of 20] of the animals) or the LATs<sup>+</sup> mutant (KOS/1) (reactivating in 18% [7 of 40] of the animals) (Fig. 4A). Statistical analysis (Fisher's exact test) of these results showed a significant difference in reactivation frequencies between the parental strain, KOS(M), and both KOS/29 ( $P = 0.02$ ) and KOS/62 ( $P = 0.002$ ). The difference between KOS(M) and KOS/1 was not significant.

**Quantitation of latently infected cells.** The preceding data suggest two alternatives. First, the LATs transcription unit might be required for induced reactivation. Second, transcription from this locus may be important prior to reactivation, i.e., in the establishment of latency, with the phenotypic expression of this function being reduced frequency of

reactivation. In order to distinguish between these two alternatives, it was essential to accurately determine the number of latently infected cells in the ganglia of animals inoculated with LATs<sup>+</sup> and LATs<sup>-</sup> mutants. By using  $\beta$ -Gal expression as a marker of latently infected neurons, ganglia latently infected with KOS/1 (LATs<sup>+</sup>) or KOS/62 (LATs<sup>-</sup>) were fixed and assayed for enzyme activity in situ. To avoid the inaccuracy inherent in generating a number from sectioned ganglia, the histochemical assay was performed with whole ganglia which were subsequently cleared and pressed.

Quantitative analysis was carried out with groups of 20 latently infected ganglia from mice inoculated via the cornea with either the LATs<sup>+</sup> (KOS/1) or the LATs<sup>-</sup> (KOS/62) mutant. This analysis revealed a dramatic difference in establishment efficiencies between KOS/1 and KOS/62 ( $P = 0.00004$ ). The number of latently infected neurons in KOS/1-infected trigeminal ganglia averaged 45.8 neurons per mouse (range, 16 to 133) and for KOS/62, the number averaged 5.9 (range, 0 to 15). Therefore, the number of latently infected neurons in ganglia of mice inoculated with the LATs<sup>-</sup> mutant was reduced nearly an order of magnitude (Fig. 4B). These data strongly suggested that the LATs locus was functioning to facilitate establishment of latency.

With the assumption that all blue neurons are equally capable of reactivating in this model, it is possible to compare the reactivation frequency observed with the variance about the mean in the number of latently infected neurons per mouse. Such an analysis predicts that about 80 latently infected neurons per mouse are required for reactivation in this model. Extrapolation of these results to KOS/62 predicts a reactivation frequency of less than 1 per 200 mice.

**Acute replication kinetics.** It was now important to demonstrate that the reduced number of latently infected cells in the ganglia of KOS/62-infected mice was not a result of inefficient replication of this virus in vivo. Therefore, the acute replication kinetics for KOS/1, KOS/62, KOS/29, and KOS(M) were determined. Groups of mice ( $n = 21$  per group) were inoculated bilaterally via corneal scarification with  $5 \times 10^4$  PFU of each virus. The amount of infectious virus in the eyes and trigeminal ganglia pooled from three animals on days 1 through 7 was determined as PFU per gram of tissue. As shown in Fig. 5, KOS/1, the LATs<sup>+</sup> mutant, replicated less efficiently than KOS(M), yielding approximately 10-fold-fewer PFU per gram in both the eyes and trigeminal ganglia. The reason for this has not been determined but may involve the loss of glycoprotein C, which has been shown to play a nonessential role in HSV infectivity (13). In contrast, both LATs<sup>-</sup> mutants (KOS/62 and KOS/29) reached titers at the periphery and in the trigeminal ganglia equivalent to those of the parental strain [KOS(M)] and with identical kinetics. Therefore, differences in the establishment or reactivation capabilities of LATs<sup>-</sup> mutants could definitely not be attributed to the inability of these viruses to replicate efficiently during the acute phase of infection or to replicate to detectable levels in ganglia after reactivation.

These results indicated that LATs were indeed functioning to facilitate establishment but did not preclude an additional role for LATs in induced reactivation. If the reduced reactivation phenotype of LATs<sup>-</sup> mutants was due solely to the reduced numbers of latently infected ganglionic neurons, increasing this number should result in increased reactivation frequency. In order to test this hypothesis, we developed a bilateral corneal scarification and snout abrasion inoculation procedure to increase the portal of entry of the

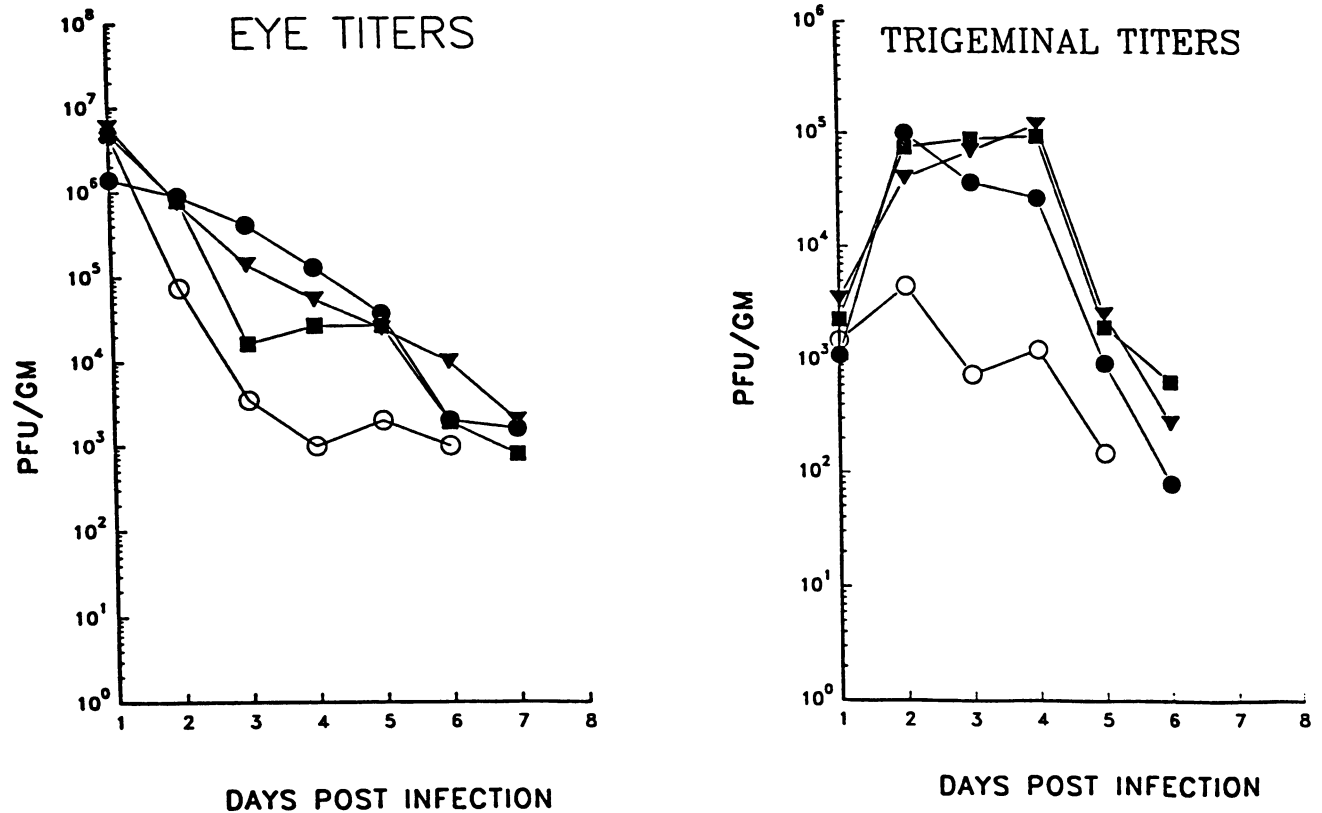

FIG. 5. Acute replication kinetics of LATs<sup>+</sup> and LATs<sup>-</sup> viruses following bilateral corneal scarification. Mice were infected as described in the text, and at the indicated times p.i., samples were assayed in triplicate for virus content. Symbols: ▼, KOS(M); ○, KOS/1; ■, KOS/62; ●, KOS/29. GM, gram.

virus. Animals inoculated by this procedure with KOS/1 and KOS/62 were evaluated 30 days p.i. for observation of induced reactivation frequency and quantitation of latently infected neurons as described above. Results from these experiments are shown in Fig. 6A. An increased frequency of reactivation in the KOS/1-infected mice (30%, 6 of 20) was seen. However, as in the previous experiment, no reactivations in KOS/62-infected animals (0 of 30) were detected.

This inoculation procedure resulted in an increase in the number of latently infected ( $\beta$ -Gal-positive) neurons in KOS/1-infected ganglia (average, 61.5; range, 17 to 125), which could explain the increase in reactivation frequency observed. KOS/62-infected animals also had an increase in the number of latently infected cells compared with animals inoculated via bilateral corneal scarification alone (average, 23.2; range, 16 to 33). However, this number was still 64% less than the number of latently infected neurons seen with KOS/1 and was still far less than the predicted number of latently infected neurons required for reactivation in this model (Fig. 6B). These data confirmed results from our first set of experiments, indicating that the LATs function to facilitate the establishment of latency. Because the number of latently infected neurons detected in KOS/62-infected mice was still very low, it was not possible to determine whether LATs also functioned directly in reactivation.

**Analysis of HSV DNA present in latently infected ganglia.** Several laboratories have previously reported that the LATs locus plays no role during the establishment of latency (16, 17, 22, 35). This conclusion was based on experiments designed to quantify HSV DNA present in latently infected

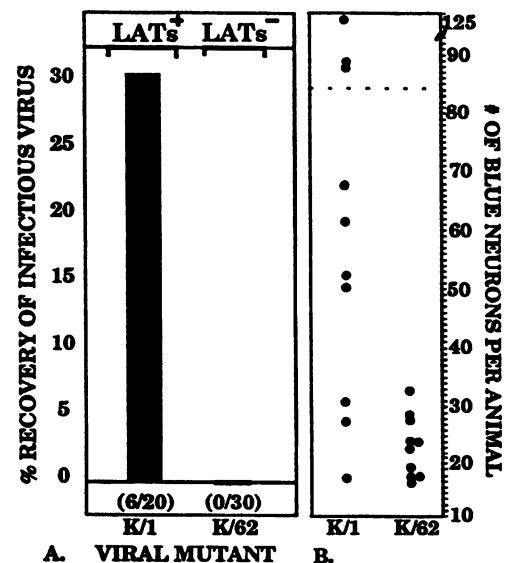

FIG. 6. Comparisons of the frequencies of in vivo reactivation (A) and the numbers of latently infected neurons (B) in trigeminal ganglia of mice latently infected with LATs<sup>+</sup> and LATs<sup>-</sup> mutants. These data are compiled from results with mice inoculated bilaterally via corneal scarification and snout abrasion. The number of animals positive for virus of the number tested is indicated below each bar in panel A. Solid circles in panel B represent individual animals. The number of blue neurons is the total number in the two trigeminal ganglia of each animal. The dashed line is drawn at the frequency of reactivation determined in panel A. Abbreviations are same as for Fig. 3.

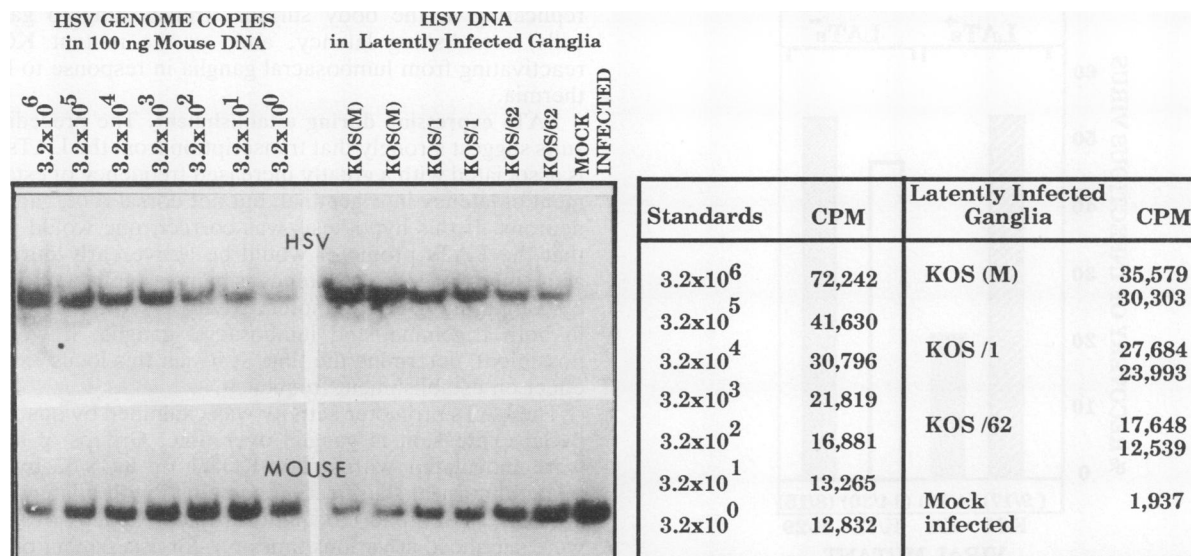

FIG. 7. Quantification of HSV DNA present in latently infected trigeminal ganglia by PCR. Mice were infected with KOS(M), KOS/1, or KOS/62 as described in the text. Thirty days p.i., ganglion pairs were harvested and DNA was extracted for quantitative PCR. Two primer pairs were present in the PCR as described in Materials and Methods. One pair is specific for the HSV-1 TK gene, and the second pair is specific for the single-copy mouse adipsin gene. PCR products were electrophoresed and blotted to nylon membranes. The blots were hybridized to a  $^{32}\text{P}$ -labeled oligonucleotide specific for the HSV TK gene product (top panels) and then stripped and hybridized to a probe specific for the product of the mouse adipsin gene (bottom panels). The left panels are a reconstruction of known amounts of HSV genomes in 100 ng of mouse DNA. The right panels show results with 100 ng of latently infected ganglionic DNA. Autoradiograms were produced for photographic purposes. The blots were also scanned on a Molecular Dynamics PhosphorImager, and counts per minute (CPM) present in the bands were determined by using ImageQuant software (table at right).

ganglia by slot blot hybridization. We next sought to determine whether the amount of HSV DNA present in latently infected ganglia was correlated with the number of  $\beta$ -Gal-positive neurons present. The purpose of these experiments was twofold: to determine the HSV genome copy number present per LATs promoter-positive neuron, and to gain evidence that some unknown difference in LATs promoter activities between KOS/1 and KOS/62 was not responsible for the observed difference in establishment frequencies identified in trigeminal ganglia as described above.

Initial experiments to quantify HSV DNA present in latently infected ganglia by slot blot hybridization were inconclusive. By preadsorbing the probe employed to a filter saturated with mouse DNA, a specific signal could be obtained at  $10^4$  HSV genomes per  $1 \mu\text{g}$  of mouse DNA. Regardless of the infecting strain,  $3 \times 10^4$  to  $2 \times 10^5$  HSV genome equivalents per microgram were detected in samples of latently infected ganglia. Although the amount of HSV DNA detected in the ganglia infected with LATs<sup>-</sup> mutants was often lower than that in the LATs<sup>+</sup> samples, the groups overlapped, a result consistent with previous reports by others (22, 35). However, the level of sensitivity was not sufficient to detect HSV DNA in all latently infected ganglia and not linear enough at this level to unambiguously document a 30 to 60% difference between strains (data not shown). Therefore, the more sensitive approach of quantitative PCR in which both HSV and mouse DNA could be simultaneously quantified was employed (18).

Pairs of trigeminal ganglia from mice latently infected with KOS(M), KOS/1, or KOS/62 were pooled, and the DNA was extracted and treated precisely as described previously (18). Results of such an analysis are shown in Fig. 7. The top panels are from an autoradiogram of the resulting blot probed with an oligonucleotide specific for the HSV TK gene

PCR product. The bottom panels are from an autoradiogram of the same blot hybridized to an oligonucleotide probe specific for the mouse adipsin gene PCR product. The radioactivity present in the bands was quantified by exposing the blots on a Molecular Dynamics PhosphorImager and analyzing the resulting image with ImageQuant software. As can be seen, a reasonable linearity was seen in the standards reconstruction experiment between 320 and  $3.2 \times 10^5$  genomes of HSV in 100 ng of mouse DNA. Linearity fell off above and below this range, and competition between the primer pairs was observed.

Both mice infected with KOS(M) had larger amounts of latent DNA than did those infected with KOS/1, indicating that this mutant did not establish abnormally high levels of latent infections. However, the KOS/62-infected mice contained significantly less latent HSV DNA than did those infected with KOS/1. In fact, very few copies were detected in one of the KOS/62-infected mice, and neither value from these animals was within the linear range of the standards. The number of genome copies present in the KOS/1-infected mice could be estimated with reasonable accuracy. With the assumption that about  $20 \mu\text{g}$  of DNA was present in a trigeminal ganglion as we performed the dissections (an average number derived during the course of these studies; data not shown), there would be  $3.6 \times 10^7$  and  $1.2 \times 10^6$  HSV genome equivalents per ganglion in the KOS/1-infected mice. These numbers are consistent with those reported by others (0.3 to 3.0 HSV genomes per cell genome [18, 35]), as there are between  $10^6$  and  $10^7$  cells in the ganglion. The average number of blue neurons present in 10 ganglia from mice inoculated with KOS/1 at the same time as those mentioned above was 31.2 (range, 13 to 146). Therefore, there were between  $3 \times 10^4$  and  $1 \times 10^6$  HSV genome equivalents per blue neuron. The biological significance and



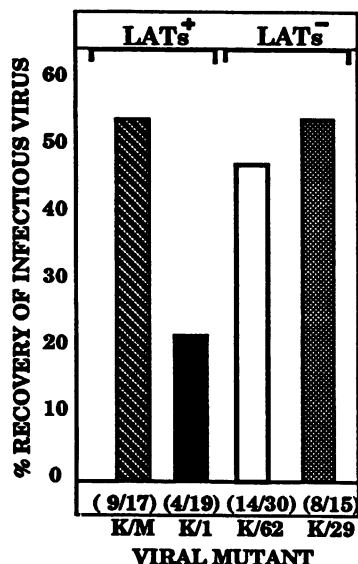

FIG. 8. Comparison of the frequency of in vivo reactivation from lumbosacral ganglia of mice latently infected with LATs<sup>+</sup> and LATs<sup>-</sup> viruses. These data were compiled from results with mice inoculated via footpad abrasion. The number of animals positive for virus of the number tested is indicated below each bar. Abbreviations are same as for Fig. 3.

activity of the HSV DNA detected by these techniques is not known (18), but the fact that less was found in ganglia latently infected with KOS/62 is consistent with the hypothesis that this mutant fails to establish latency efficiently.

**Establishment and reactivation in lumbosacral ganglia.** Because hyperthermia effectively induces reactivation in vivo in lumbosacral ganglia (34a), it was possible to test LATs<sup>-</sup> mutants for establishment as well as induced reactivation phenotype at this ganglionic site. Groups of mice were inoculated via the footpad with equivalent titers of KOS(M), KOS/1, KOS/62, or KOS/29. Thirty days p.i., latently infected animals were evaluated for induced reactivation frequency, and the number of latently infected neurons was determined as described above.

In direct contrast to the results obtained with trigeminal ganglia, the frequency of induced reactivations of these same mutants from the lumbosacral ganglia were indistinguishable from the wild type (Fig. 8). The two LATs<sup>-</sup> mutants, KOS/29 and KOS/62, reactivated by induction in 53% (8 of 15) and 47% (14 of 30) of the animals, respectively. These values are not statistically different from the 53% (9 of 17 animals) reactivation rate of the parental strain KOS(M) and are higher than that for the LATs<sup>+</sup> mutant, KOS/1, at 21% (4 of 19 animals). Thus, the reduced reactivation phenotype observed with trigeminal ganglia was not observed with lumbosacral ganglia.

The number of latently infected neurons in KOS/62 (LATs<sup>-</sup>)-infected lumbosacral ganglia was now higher (average, 80 per mouse; range, 51 to 101) than the number in KOS/1-infected ganglia (average, 56; range, 43 to 84). These data demonstrate that when sufficient numbers of lumbosacral ganglionic neurons were latently infected with LATs<sup>-</sup> mutants, induced reactivation was also efficient. In addition, the block in establishment observed with the trigeminal ganglia was not apparent with the lumbosacral ganglia. The results demonstrate clearly that no generalized defect is present in the mutant KOS/62. This virus is fully capable of

replicating at the body surface, transporting to ganglion cells, establishing latency, and, as the mutant KOS/29, reactivating from lumbosacral ganglia in response to hyperthermia.

**LATs expression during establishment.** The preceding results suggest strongly that transcription from the LATs locus is associated with a greatly increased frequency of establishment of latency in trigeminal, but not dorsal root, ganglionic neurons. If this hypothesis was correct, one would predict that the LATs promoter would be active early during the acute infection stage as latency is being established. Further, by comparing LATs promoter activity of KOS/1 and KOS/62 in both trigeminal and lumbosacral ganglia, it would be possible to determine the time at which this locus exerts its effect on establishment frequency.

The LATs promoter activity was examined by quantifying  $\beta$ -Gal expression in ganglia over time. Groups of animals were inoculated with either KOS/1 or KOS/62 by using bilateral corneal scarification combined with bilateral snout abrasion or footpad inoculation routes. Groups of animals were sacrificed at various times p.i. for assessment of LATs promoter activity. These data are summarized in Fig. 9.

Blue cells could be detected as early as 2 days p.i. with either virus at both anatomic locations. However, the number detected was low. On day 3, equivalent numbers of blue neurons were seen in trigeminal ganglia from the KOS/1- and KOS/62-infected mice ( $n = 8$  ganglia for each; averages were 163.5 and 193.8, respectively, and ranges were 72 to 225 and 95 to 292, respectively). This was also true of day 4 ganglia, although by this time one ganglion from a mouse infected with KOS/62 had a low number of blue neurons (KOS/1,  $n = 10$ , average was 168.2, and range was 77 to 192; for KOS/62,  $n = 10$ , average was 157.7, and range was 32 to 304). By day 6, the difference between KOS/1 and KOS/62 observed at 30 days p.i. was readily apparent and statistically very significant (KOS/1,  $n = 12$ , average was 197, and range was 103 to 390; KOS/62,  $n = 14$ , average was 90.9, and range was 24 to 152;  $P = 0.0004$ , unpaired T test).

As shown in Fig. 10, many intensely blue neurons with blue axonal processes were present on day 6 in trigeminal and lumbosacral ganglia from both KOS/1- and KOS/62-infected animals. It was evident at this time point that for the trigeminal ganglia, there were far fewer blue neurons in KOS/62-infected ganglia than in ganglia infected with equivalent titers of KOS/1 (Fig. 10A and B). In contrast, lumbosacral ganglia examined on day 6 from mice inoculated with KOS/1 or KOS/62 were indistinguishable (Fig. 10C and D). At both sites by day 15, the intensity of blue was markedly lower and the actual number of blue neurons had decreased in parallel in KOS/1- and KOS/62-infected animals. This decrease in the number of blue neurons continued through day 30. The overall intensity also further diminished, the diffuse cytoplasmic staining present earlier in most cells was no longer apparent, and a punctate distribution of the enzyme within the positive neurons was most common.

A most significant finding of this experiment was that equal numbers of  $\beta$ -Gal-positive neurons were seen in trigeminal ganglia infected with either KOS/1 or KOS/62 through 3 to 4 days p.i., after which time the numbers began to diverge. Clearly then, both of these viruses reached the ganglia and expressed the LATs promoter in equivalent numbers of neurons early after infection. These data suggested that transcription from the LATs locus exerted its influence early during acute infection (between days 3 and 6) and might be involved in the switch from acute infection to latency. If this was the case, one would predict that with



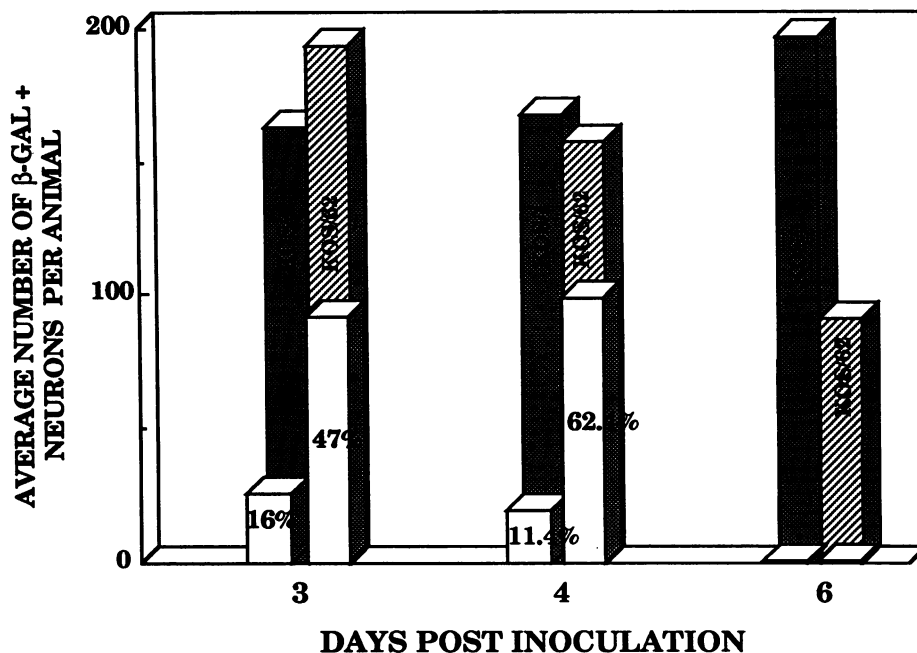

FIG. 9. LAT promoter transcription and HSV antigen production during the establishment of latency. Shown is the comparison of the average numbers of LATs promoter transcription positive (blue) neurons and the percentages of these which were also HSV antigen positive in trigeminal ganglia of KOS/1- and KOS/62-infected mice on days 3, 4, and 6 p.i. Mice were bilaterally inoculated on the cornea and snout. The total number of blue neurons per animal was determined from ganglionic whole mounts stained with X-Gal as described in the text. Each bar represents the average from 8 to 14 animals. The ganglia were subsequently processed for the detection of HSV antigen, and the percentage of HSV antigen-positive  $\beta$ -Gal-positive neurons was determined by examining serial sections. A minimum of 125  $\beta$ -Gal-positive neurons were examined for each group. The superimposed open bars represent the percentages of  $\beta$ -Gal-positive HSV antigen-positive neurons determined from the sectioned ganglia (see text for details).

LATs<sup>+</sup> strains such as KOS/1, expression of the LATs promoter would be associated with a shutoff of viral protein synthesis on days 3 to 4 p.i. and that two populations of cells would be detected at this time: one expressing LATs and one expressing viral antigen. In contrast, with KOS/62 (LATs<sup>-</sup>), expression of the LATs promoter would colocalize with HSV antigen in neurons. Further, such a difference between these strains should be detectable in trigeminal but not lumbosacral ganglionic neurons.

Immunohistochemical staining for HSV antigens was combined with detection of  $\beta$ -Gal to examine the relationship between LATs promoter activity and antigen production. Animals were inoculated as above with either KOS/1 or KOS/62, and relevant ganglia were harvested and processed on days 3 and 4 p.i. Serial sections were examined with a 100 $\times$  oil immersion objective, and care was taken to examine several levels of each blue neuron for the presence of HSV antigen. It was found that in all cases, there were 5 to 10 times more antigen-positive neurons than neurons expressing  $\beta$ -Gal. Therefore, the LATs promoter was active only in a small subset of infected neurons. HSV antigen could be detected in some of the blue neurons. It was of particular interest that compared with results for ganglia infected with KOS/1, there was a significantly higher frequency of colocalization of  $\beta$ -Gal and HSV antigen in KOS/62-infected trigeminal but not lumbosacral ganglia (summarized in Fig. 9).

In KOS/62-infected trigeminal ganglia on day 3 p.i., 47% (118 of 249)  $\beta$ -Gal-positive neurons also contained HSV antigen. Only 16% (21 of 131) of the blue neurons in KOS/1-infected ganglia also contained HSV antigen. By day 4 p.i., the difference between the strains was even greater

(colocalization with KOS/62, 62.4% [103 of 165]; colocalization with KOS/1, 11.4% [14 of 125]). In lumbosacral ganglia, colocalization occurred at about the same frequency with both viruses (day 3, colocalization with KOS/1, 23% [30 of 130]; colocalization with KOS/62, 20% [40 of 200]; day 4, colocalization with KOS/1, 18% [15 of 85]; colocalization with KOS/62, 14% [30 of 210]).

With both viruses, the amount and subcellular distribution of HSV antigen staining in  $\beta$ -Gal-expressing cells was variable, ranging from pale to intense staining restricted to the nucleus to diffuse or punctate cytoplasmic staining. Vacuolar degeneration and abnormal nuclear morphology were occasionally apparent, indicating that at least some of these neurons did not survive. These findings may account for the reduction in establishment of latency seen with KOS/62 in trigeminal ganglia. Indeed, the nearly threefold decrease in establishment seen with this inoculation route is in close agreement with the three to fourfold increase in antigen-positive,  $\beta$ -Gal-positive cells and indicates that KOS/62 may not be efficiently shut off during establishment.

**Maintenance of latency.** Long-term experiments were performed to determine whether the absence of the LATs transcription unit resulted in a more rapid loss of latently infected neurons. Animals from the group infected as described above were maintained and analyzed for the virus' ability to reactivate in cocultivation and for the number of blue neurons present at 90 and 140 days p.i. As can be seen in Fig. 3B, virus in 100% of the ganglia from animals infected with both LATs<sup>+</sup> and LATs<sup>-</sup> mutants reactivated by explant cocultivation at 140 days p.i. This is in agreement with a previous report examining the long-term maintenance of an LATs<sup>-</sup> mutant (35). However, the kinetics of reactivation of

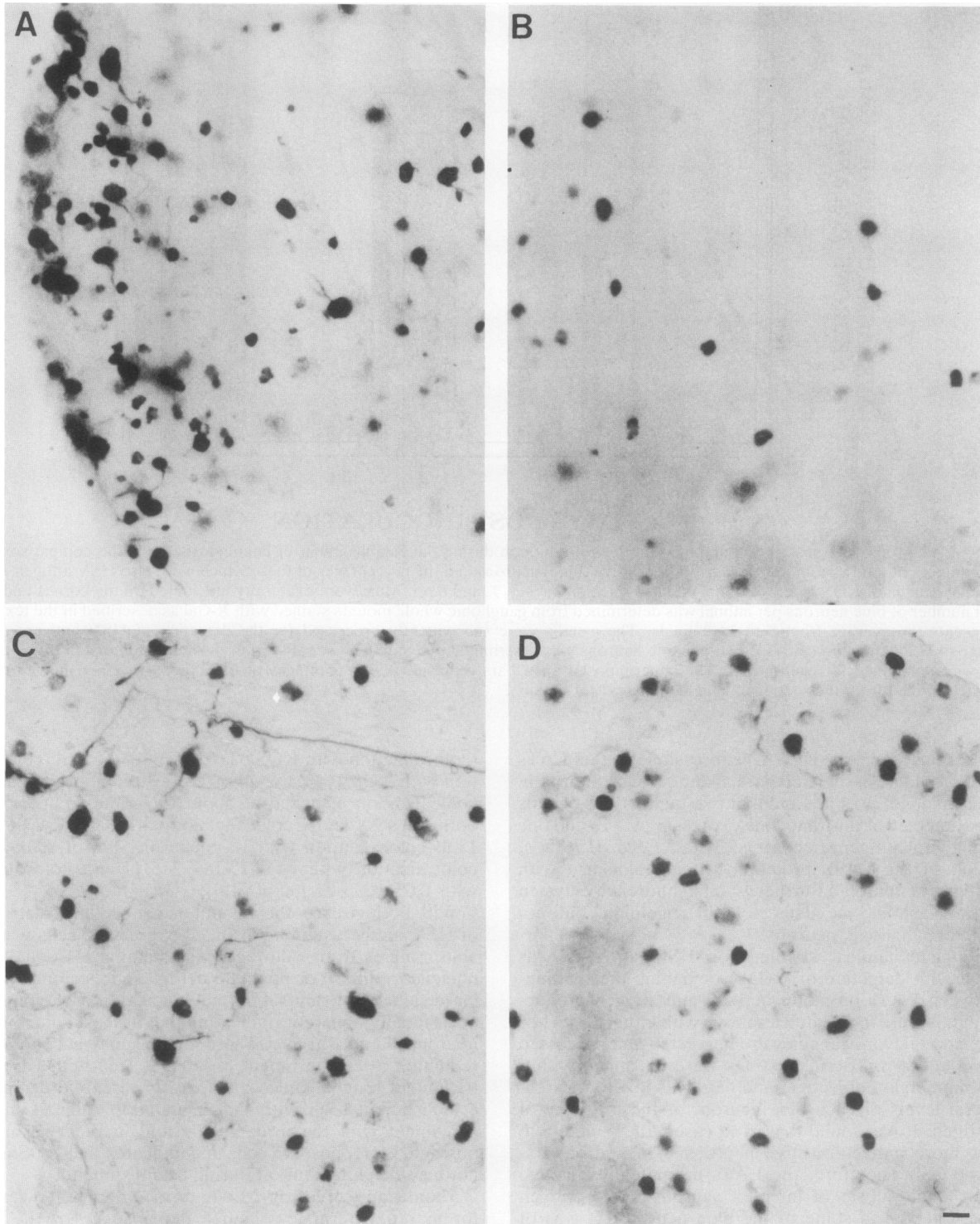

FIG. 10. In situ localization of *E. coli*  $\beta$ -Gal activity in representative whole mounts of trigeminal (A and B) and lumbosacral (C and D) ganglia 6 days after inoculation with equivalent titers of the LATs<sup>+</sup> mutant KOS/1 (A and C) and the LATs<sup>-</sup> mutant KOS/62 (B and D).

both viruses were reduced significantly from those seen at 30 days p.i. (compare with Fig. 3A). The number of  $\beta$ -Gal-positive neurons also declined at 90 days p.i. ( $n = 20$ ; for KOS/1, the average was 39.9 and the range was 20 to 59; for KOS/62, the average was 12.4 and the range was 3 to 27).

This trend continued through 140 days ( $n = 6$ ; for KOS/1 the average was 30.6 and the range was 24 to 45; for KOS/62, the average was 11.6 and the range was 6 to 18), but the decrease observed was not significantly different from the observations at 90 days. Therefore, regardless of the genotype,

latent infections were maintained with comparable efficiencies throughout the 4.5-month period of study, indicating no role for LATs in maintenance. The number of cells expressing  $\beta$ -Gal decreased over the first 30 days p.i. with both viruses (see above), and this trend continued for the length of the study. This suggests that some LATs-expressing neurons either down regulated this promoter, lost the virus, or died. Further, the kinetics of reactivation in cocultivation cultures reflected the number of blue neurons detected. Thus, as the number detected was reduced, reactivation in culture required more time.

## DISCUSSION

The LATs are a related group of RNA molecules found in the nucleus of a population of neurons in latently infected ganglia (4, 5, 20, 26, 33, 38, 40, 44, 45). Because this is the only region of the HSV genome transcriptionally active during latency, a great deal of effort has been placed in determining the functional significance of the LATs or protein products from this locus. The LATs RNAs have been mapped on the viral genome by *in situ* hybridization of latently infected ganglia by using a series of small oligonucleotide probes (45). The promoter for the LATs has been identified some 700 bp upstream from the start of the LATs (8). This has led to the demonstration that the LATs are a metabolic byproduct of a larger transcription unit (7, 10). However, to date, no functional mRNA or protein encoded by this locus has been identified.

Studies with mice have found that LATs<sup>-</sup> mutants reactivate *in vitro* with reduced kinetics (22, 37) or reduced frequency (22) in trigeminal ganglia in explant cocultivation experiments. In similar experiments, others have shown that LATs mutants reactivate with wild-type kinetics and frequency in mouse trigeminal ganglia (2) and dorsal root ganglia (35) and rabbit trigeminal ganglia (14). The reduced reactivation kinetics observed in the studies above has been interpreted as a reduced ability of LATs<sup>-</sup> mutants to reactivate. Our data suggest that this phenomenon may be explained at least in part by reduced establishment by such mutants.

There has been only one report of *in vivo* reactivation studies with an LATs mutant. After iontophoresis of epinephrine in the rabbit eye model, an LATs<sup>-</sup> mutant was not induced to reactivate above the background of spontaneous virus shedding. The authors concluded that the LATs locus enhanced induced reactivation but were unable to determine whether the LATs were an absolute requirement (14).

Analysis of these findings is complicated by the fact that it is not possible to quantify the establishment of latency by LATs<sup>-</sup> mutants on a cellular level. The ability of HSV-1 LATs mutants to establish latent infections has been addressed by indirect measures, including determination of acute viral replication kinetics and quantitation of viral DNA extracted from ganglion tissues (14, 16, 22). These experiments have led to the general consensus that the LATs locus is not required for establishment of latency (39). Unfortunately, these methods are not sensitive enough to detect viral DNA in all ganglia known to be latently infected (14) and may not reflect the true amount of biologically active viral DNA present (22).

In this study, it was demonstrated that KOS/29 reactivated *in vivo* in trigeminal ganglia in response to hyperthermia, although with greatly reduced frequency. In lumbosacral ganglia this mutant, as well as the LATs<sup>-</sup> mutant KOS/62, reactivated with wild-type frequency. These findings dem-

onstrate that the LATs locus is not an absolute requirement for induced reactivation from trigeminal ganglia and appears to play no role in induced reactivation from the lumbosacral ganglia in this model. Analysis of establishment of latency by the LATs<sup>-</sup> mutant KOS/62 following corneal inoculation demonstrated 87% fewer latently infected neurons in trigeminal ganglia than was found with the LATs<sup>+</sup> mutant KOS/1. Further confirmation of a defect in establishment is the fact that quantitative PCR revealed fewer HSV genomes present in KOS/62 latently infected ganglia. Reduced establishment is a likely explanation for the lack of reactivation of this mutant from this anatomic location. However, our findings do not preclude the possibility that the LATs transcription unit may also function in reactivation from this site. In lumbosacral ganglia, KOS/62 established as many as or more latent infections than KOS/1 and reactivated with wild-type frequency.

Examination of ganglionic neurons for LATs promoter activity ( $\beta$ -Gal) and HSV antigen during the establishment phase of infection demonstrated that the LATs promoter was active in only a small subset of infected neurons. In KOS/1-infected ganglia, the great majority of  $\beta$ -Gal-positive neurons contained no HSV antigen, a finding consistent in both trigeminal and lumbosacral ganglia. Conversely, in trigeminal ganglia infected with KOS/62, the majority of  $\beta$ -Gal-positive neurons contained HSV antigen, while in lumbosacral ganglia, the extent of colocalization was similar to that observed with KOS/1. Light microscopic examination indicated that at least some of these  $\beta$ -Gal-positive, antigen-positive neurons did not survive. These results strongly suggest that viral shutoff in trigeminal neurons is inefficient in the absence of LATs transcription. Thus, we conclude that expression of the HSV-1 LATs locus facilitates establishment of latency in the trigeminal but not the lumbosacral ganglia. The LATs function is not an absolute requirement but serves to greatly increase the number of neurons in which establishment occurs.

In humans, the most common site of HSV-1 latency is the trigeminal ganglia, resulting from primary infection of the oral mucosa. Primary oral-labial infections with HSV-1 recur more frequently than such infections with HSV-2. The converse is also true in that HSV-2 recurrences are much more prevalent than HSV-1 recurrences after primary genital infection (21, 32). However, to date, specific viral functions which contribute to this ganglionic site-specific behavior have not been identified. This is the first report of an HSV-1 genotype expressed as distinct phenotypes in ganglia at different anatomic locations. This finding emphasizes the importance of considering the anatomic site used for experimental analyses of establishment and reactivation functions of HSV-1 LATs. Furthermore, it suggests the intriguing possibility that the LATs transcription unit may play a role in the clinical recurrence patterns of HSV-1 and HSV-2 in humans.

The fact that the HSV-1 LATs function to enhance establishment in trigeminal but not lumbosacral neurons would seem at first to be a paradox, and it may be that the mouse model breaks down in this regard. However, our findings are consistent with the pattern of recurrent disease in humans if one postulates that the permissiveness of neurons at various ganglionic sites varies and that this permissiveness plays an important role in the progression of a reactivation event to disease recurrence at the body surface. It is very clear that establishment of latency can occur in the absence of LATs or most other HSV gene transcription (15-18, 22, 27, 35, 37). Therefore, the idea of a default establishment

pathway, due to the nonpermissiveness of the neuron, must be entertained. If one postulates that lumbosacral neurons are less permissive than trigeminal neurons, one could predict that this default pathway might be dominant for HSV-1 and that the effect of the absence of LATs transcription in HSV-1 strains would not be seen in this tissue. Conversely, in more permissive trigeminal neurons the effect would be apparent, as the default pathway would no longer be as dominant.

Neurovirulence is clearly not a prerequisite for the establishment of or reactivation from latency (43). Therefore, neurovirulence is likely to be titrated by a combination of the requirement to preserve the host and the requirement to replicate in neurons following reactivation to produce recurrent disease. If lumbosacral neurons are less permissive, HSV-2 strains would be predicted to be more neurovirulent than HSV-1 strains. This has long been known to be true (28–31). This model would also predict that HSV-1 could establish latency in lumbosacral neurons and, because HSV-1 is less capable of replication in these cells, reactivate without causing apparent disease at the body surface. An additional prediction of this hypothesis is that HSV-2 strains would also carry an establishment function which would be apparent in the normal target tissue. It has recently been reported that HSV-2 also encodes LATs during latency and that the transcription unit is similar to but distinct from that seen in HSV-1 (25). It will be of great interest to examine the roles of the HSV-2 LATs in establishment and reactivation and compare the phenotypic expression of HSV-2 LATs<sup>-</sup> mutants in trigeminal and lumbosacral ganglia. Such experiments are currently in progress.

Finally, a variety of procedures have been shown to induce the reactivation of HSV-1 experimentally, and these include UV light, superinfection, chemical treatments, iontophoresis of epinephrine, physical trauma, neurectomy (reviewed in reference 34), and transient hyperthermia (34a). It should be emphasized that the interplay of viral and host factors which lead to reactivation and recurrent disease is undoubtedly complex and that the relative importance of any one factor may be dependent on the nature of the induction event and, as demonstrated in this study, the specific ganglionic site of latency.

#### ACKNOWLEDGMENTS

This work was supported by Public Health Service grant NS 25879 of the National Institute of Neurological and Communicative Disorders and Stroke and a Life Health Insurance Medical Research Fund grant to R.L.T. Additional support was provided by PHS grant AI 22667 from the National Institute of Allergy and Infectious Diseases to L. Stanberry and R.L.T.

We especially thank L. T. Feldman (UCLA) for mutants KOS/62 and KOS/1 prior to publication.

#### REFERENCES

1. Batchelor, A. H., and P. O'Hare. 1990. Regulation and cell-type-specific activity of a promoter located upstream of the latency-associated transcript of herpes simplex virus type 1. *J. Virol.* **64**:3269–3276.
2. Block, T. M., J. G. Spivack, I. Steiner, S. Deshmane, M. T. McIntosh, R. P. Lirette, and N. W. Fraser. 1990. A herpes simplex virus type 1 latency-associated transcript mutant reactivates with normal kinetics from latent infection. *J. Virol.* **64**:3417–3426. (Erratum, **64**:4603).
3. Costa, R. H., K. G. Draper, G. Devi-Rao, R. L. Thompson, and E. K. Wagner. 1985. Virus-induced modification of the host cell is required for expression of the bacterial chloramphenicol acetyltransferase gene controlled by a late herpes simplex virus promoter (VP5). *J. Virol.* **56**:19–30.
4. Croen, K. D., J. M. Ostrove, L. J. Dragovic, J. E. Smialek, and S. E. Straus. 1987. Latent herpes simplex virus in human trigeminal ganglia. Detection of an immediate early gene. *N. Engl. J. Med.* **317**:1427–1432.
5. Croen, K. D., J. M. Ostrove, L. J. Dragovic, and S. E. Straus. 1988. Patterns of gene expression and sites of latency in human nerve ganglia are different for varicella-zoster and herpes simplex viruses. *Proc. Natl. Acad. Sci. USA* **85**:9773–9777.
6. Deatly, A. M., J. G. Spivack, E. Lavi, and N. W. Fraser. 1987. RNA from an immediate early region of the type 1 herpes simplex virus genome is present in the trigeminal ganglia of latently infected mice. *Proc. Natl. Acad. Sci. USA* **84**:3204–3208.
7. Devi-Rao, G. B., S. A. Goodart, L. M. Hecht, R. Rochford, M. K. Rice, and E. K. Wagner. 1991. Relationship between polyadenylated and nonpolyadenylated herpes simplex virus type 1 latency-associated transcripts. *J. Virol.* **65**:2179–2190.
8. Dobson, A. T., F. Sedarati, G. Devi-Rao, W. M. Flanagan, M. J. Farrell, J. G. Stevens, E. K. Wagner, and L. T. Feldman. 1989. Identification of the latency-associated transcript promoter by expression of rabbit beta-globin mRNA in mouse sensory nerve ganglia latently infected with a recombinant herpes simplex virus. *J. Virol.* **63**:3844–3851.
9. Draper, K. G., G. Devi-Rao, R. H. Costa, E. D. Blair, R. L. Thompson, and E. K. Wagner. 1986. Characterization of the genes encoding herpes simplex virus type 1 and type 2 alkaline exonucleases and overlapping proteins. *J. Virol.* **57**:1023–1036.
10. Farrell, M. J., A. T. Dobson, and L. T. Feldman. 1991. Herpes simplex virus latency-associated transcript is a stable intron. *Proc. Natl. Acad. Sci. USA* **88**:790–794.
11. Feldman, L. T. Unpublished data.
12. Feldman, L. T., A. T. Dobson, and T. Margolis. Unpublished data.
13. Herold, B. C., D. WuDunn, N. Soltys, and P. G. Spear. 1991. Glycoprotein C of herpes simplex virus type 1 plays a principal role in the adsorption of virus to cells and in infectivity. *J. Virol.* **65**:1090–1098.
14. Hill, J. M., F. Sedarati, R. T. Javier, E. K. Wagner, and J. G. Stevens. 1990. Herpes simplex virus latent phase transcription facilitates *in vivo* reactivation. *Virology* **174**:117–125.
15. Ho, D. Y., and E. S. Mocarski. 1989. Herpes simplex virus latent RNA (LATs) is not required for latent infection in the mouse. *Proc. Natl. Acad. Sci. USA* **86**:7596–7600.
16. Izumi, K. M., A. M. McKelvey, G. Devi-Rao, E. K. Wagner, and J. G. Stevens. 1989. Molecular and biological characterization of a type 1 herpes simplex virus (HSV-1) specifically deleted for expression of the latency associated transcript (LATs). *Microb. Pathog.* **7**:121–134.
17. Javier, R. T., J. G. Stevens, V. B. Dissette, and E. K. Wagner. 1988. A herpes simplex virus transcript abundant in latently infected neurons is dispensable for establishment of the latent state. *Virology* **166**:254–257.
18. Katz, J. P., E. T. Bodin, and D. M. Coen. 1990. Quantitative polymerase chain reaction analysis of herpes simplex virus DNA in ganglia of mice infected with replication-incompetent mutants. *J. Virol.* **64**:4288–4295.
19. Krause, P. R., K. D. Croen, J. M. Ostrove, and S. E. Straus. 1990. Structural and kinetic analyses of herpes simplex virus type 1 latency-associated transcripts in human trigeminal ganglia and in cell culture. *J. Clin. Invest.* **86**:235–241.
20. Krause, P. R., K. D. Croen, S. E. Straus, and J. M. Ostrove. 1988. Detection and preliminary characterization of herpes simplex virus type 1 transcripts in latently infected human trigeminal ganglia. *J. Virol.* **62**:4819–4823.
21. Lafferty, W., M. Remington, C. Winter, A. Fahlander, and L. Corey. 1985. Natural history of concomitant pharyngeal and genital HSV infection: influence on viral type and anatomic site on recurrence rates. *Clin. Res.* **33**:408A.
22. Leib, D. A., C. L. Bogard, M. Kosz-Vnenchak, K. A. Hicks, D. M. Coen, D. M. Knipe, and P. A. Schaffer. 1989. A deletion mutant of the latency-associated transcript of herpes simplex virus type 1 reactivates from the latent state with reduced

- frequency. *J. Virol.* **63**:2893–2900.
23. Leib, D. A., K. C. Nadeau, S. A. Rundle, and P. A. Schaffer. 1991. The promoter of the latency-associated transcripts of herpes simplex virus type 1 contains a functional cAMP-response element: role of the latency-associated transcripts and cAMP in reactivation of viral latency. *Proc. Natl. Acad. Sci. USA* **88**:48–52.
  24. McGeoch, D. J. 1989. The genomes of the human herpesviruses: contents, relationships, and evolution. *Annu. Rev. Microbiol.* **43**:235–265.
  25. Mitchell, W. J., S. L. Deshmane, A. Dolan, D. J. McGeoch, and N. W. Fraser. 1990. Characterization of herpes simplex virus type 1 transcription during latent infection of mouse trigeminal ganglia. *J. Virol.* **64**:5342–5348.
  26. Mitchell, W. J., R. P. Lirette, and N. W. Fraser. 1990. Mapping of low abundance latency-associated RNA in the trigeminal ganglia of mice latently infected with herpes simplex virus type 1. *J. Gen. Virol.* **71**:125–132.
  27. Mitchell, W. J., I. Steiner, S. M. Brown, A. R. MacLean, J. H. Subak-Sharpe, and N. W. Fraser. 1990. A herpes simplex virus type 1 variant, deleted in the promoter region of the latency-associated transcripts, does not produce any detectable minor RNA species during latency in the mouse trigeminal ganglion. *J. Gen. Virol.* **71**:953–957.
  28. Mogensen, S. 1977. Role of macrophages in hepatitis induced by herpes simplex virus types 1 and 2 in mice. *Infect. Immun.* **15**:686–691.
  29. Mogensen, S. C., B. Teisner, and H. K. Andersen. 1974. Focal necrotic hepatitis in mice as a biological marker for differentiation of herpesvirus hominis type 1 and type 2. *J. Gen. Virol.* **25**:151–155.
  30. Plummer, G., J. L. Waner, and C. P. Bowling. 1968. Comparative studies of type 1 and type 2 herpes simplex viruses. *Br. J. Exp. Pathol.* **49**:202–208.
  31. Plummer, G., J. L. Waner, A. Phuangsab, and C. R. Goodheart. 1970. Type 1 and type 2 herpes simplex viruses: serological and biological differences. *J. Virol.* **5**:51–59.
  32. Reeves, W. C., L. Corey, H. G. Adams, L. A. Vontver, and K. K. Holmes. 1982. Risk of recurrence after first episodes of genital herpes: relation to HSV type and antibody response. *N. Engl. J. Med.* **305**:315–319.
  33. Rock, D. L., A. B. Nesburn, H. Ghiasi, J. Ong, T. L. Lewis, J. R. Lokensgard, and S. L. Wechsler. 1987. Detection of latency-related viral RNAs in trigeminal ganglia of rabbits latently infected with herpes simplex virus type 1. *J. Virol.* **61**:3820–3826.
  34. Roizman, B., and A. E. Sears. 1990. Herpes simplex viruses and their replication, p. 1795–1841. *In* B. N. Fields, et al. (ed.), *Virology*, 2nd ed. Raven Press, New York.
  - 34a. Sawtell, N. M., and R. L. Thompson. 1992. Rapid in vivo reactivation of herpes simplex virus in latently infected murine ganglionic neurons after transient hyperthermia. *J. Virol.* **66**:2150–2156.
  35. Sedarati, F., K. M. Izumi, E. K. Wagner, and J. G. Stevens. 1989. Herpes simplex virus type 1 latency-associated transcription plays no role in establishment or maintenance of a latent infection in murine sensory neurons. *J. Virol.* **63**:4455–4458.
  36. Spivack, J. G., and N. W. Fraser. 1988. Expression of herpes simplex virus type 1 latency-associated transcripts in the trigeminal ganglia of mice during acute infection and reactivation of latent infection. *J. Virol.* **62**:1479–1485.
  37. Steiner, I., J. G. Spivack, R. P. Lirette, S. M. Brown, A. R. MacLean, J. H. Subak-Sharpe, and N. W. Fraser. 1989. Herpes simplex virus type 1 latency-associated transcripts are evidently not essential for latent infection. *EMBO J.* **8**:505–511.
  38. Steiner, I., J. G. Spivack, D. R. O'Boyle, E. Lavi, and N. W. Fraser. 1988. Latent herpes simplex virus type 1 transcription in human trigeminal ganglia. *J. Virol.* **62**:3493–3496.
  39. Stevens, J. G. 1989. Human herpesviruses: a consideration of the latent state. *Microbiol. Rev.* **53**:318–332.
  40. Stevens, J. G., E. K. Wagner, G. B. Devi-Rao, M. L. Cook, and L. T. Feldman. 1987. RNA complementary to a herpesvirus alpha gene mRNA is prominent in latently infected neurons. *Science* **235**:1056–1059.
  41. Thompson, R. L., M. L. Cook, G. B. Devi-Rao, E. K. Wagner, and J. G. Stevens. 1986. Functional and molecular analyses of the avirulent wild-type herpes simplex virus type 1 strain KOS. *J. Virol.* **58**:203–211.
  42. Thompson, R. L., S. K. Rogers, and M. A. Zerhusen. 1989. Herpes simplex virus neurovirulence and productive infection of neural cells is associated with a function which maps between 0.82 and 0.832 map units on the HSV genome. *Virology* **172**:435–450.
  43. Thompson, R. L., and J. G. Stevens. 1983. Biological characterization of a herpes simplex virus intertypic recombinant which is completely and specifically non-neurovirulent. *Virology* **131**:171–179.
  44. Wagner, E. K., W. M. Flanagan, G. Devi-Rao, Y. F. Zhang, J. M. Hill, K. P. Anderson, and J. G. Stevens. 1988. The herpes simplex virus latency-associated transcript is spliced during the latent phase of infection. *J. Virol.* **62**:4577–4585.
  45. Wechsler, S. L., A. B. Nesburn, R. Watson, S. M. Slanina, and H. Ghiasi. 1988. Fine mapping of the latency-related gene of herpes simplex virus type 1: alternative splicing produces distinct latency-related RNAs containing open reading frames. *J. Virol.* **62**:4051–4058.
  46. Wheatley, S. C., L. M. Kemp, J. N. Wood, and D. S. Latchman. 1990. Cell lines derived from dorsal root ganglion neurons are nonpermissive for HSV and express only the latency-associated transcript following infection. *Exp. Cell. Res.* **190**:243–246.
  47. Zwaagstra, J. C., H. Ghiasi, S. M. Slanina, A. B. Nesburn, S. C. Wheatley, K. Lillycrop, J. Wood, D. S. Latchman, K. Patel, and S. L. Wechsler. 1990. Activity of herpes simplex virus type 1 latency-associated transcript (LAT) promoter in neuron-derived cells: evidence for neuron specificity and for a large LAT transcript. *J. Virol.* **64**:5019–5028.