

## Supporting Information

# C-H Bonds as Ubiquitous Functionality: A General Approach to Complex Arylated Pyrazoles via Sequential Regioselective C-arylation and N-alkylation Enabled by SEM-group Transposition

## <sup>1</sup>H and <sup>13</sup>C NMR Spectra

*Roman Goikhman, Teresa L. Jacques, Dalibor Sames\**

Department of Chemistry, Columbia University, 3000 Broadway, New York, New York 10027

sames@chem.columbia.edu

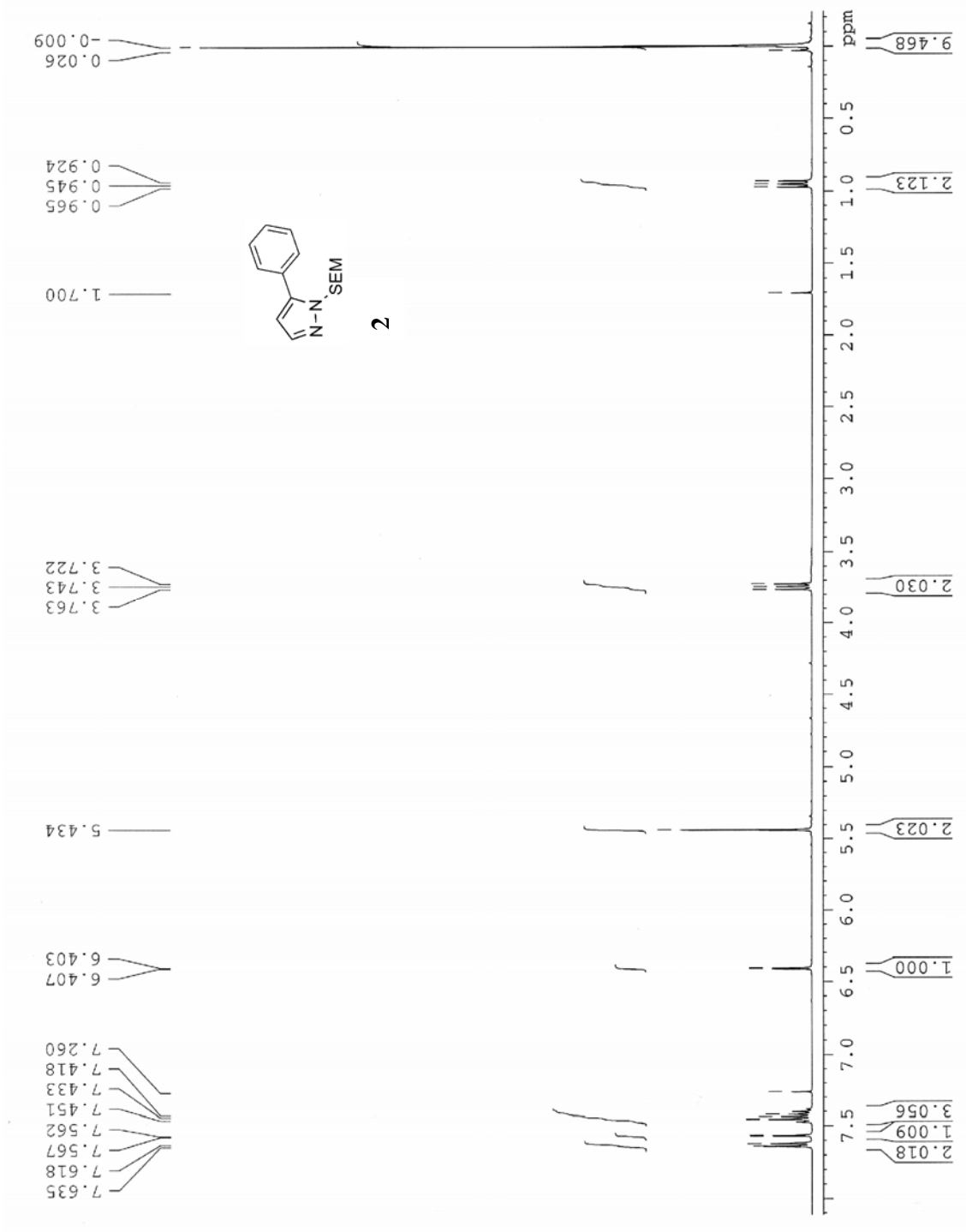

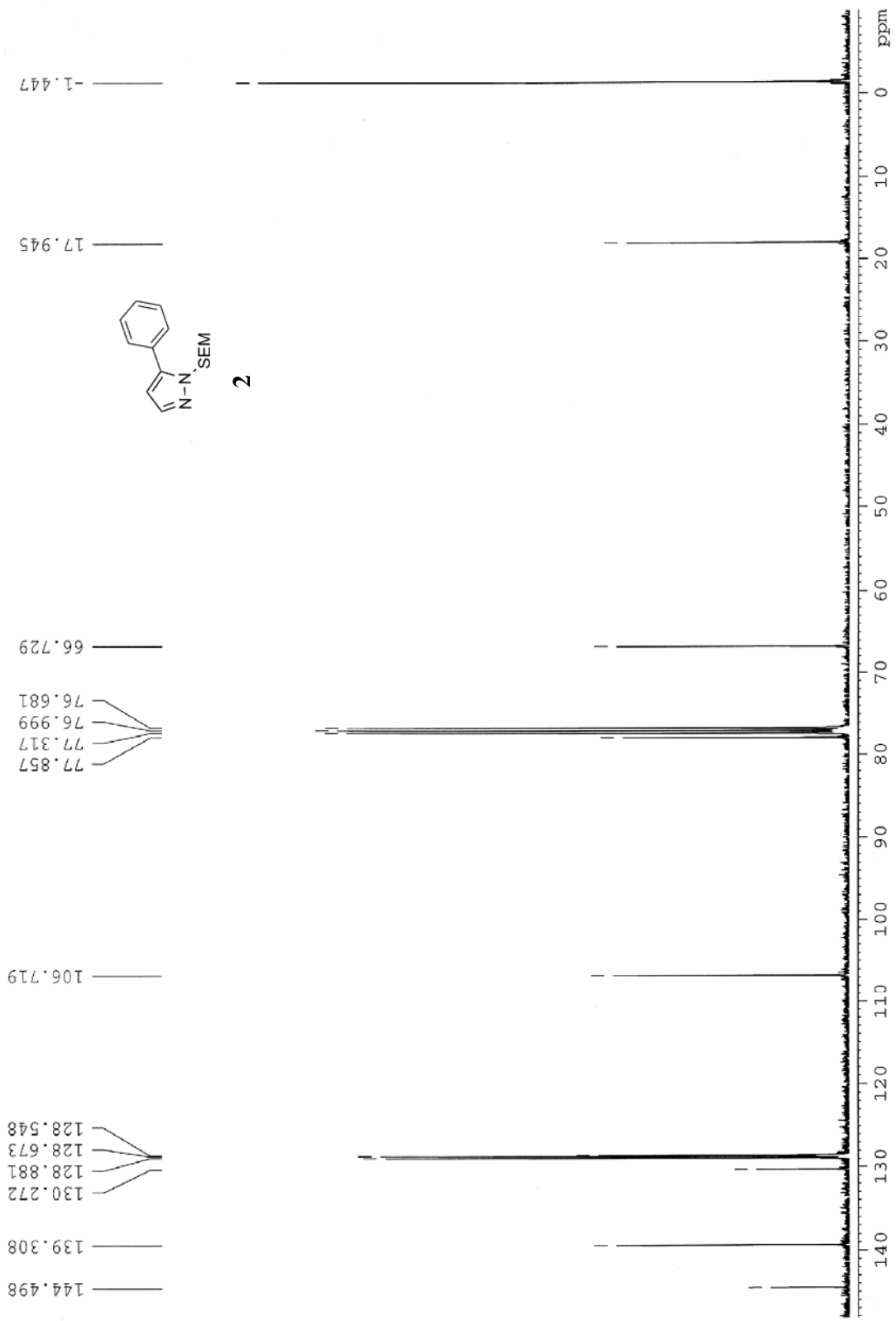

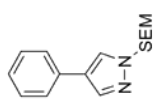
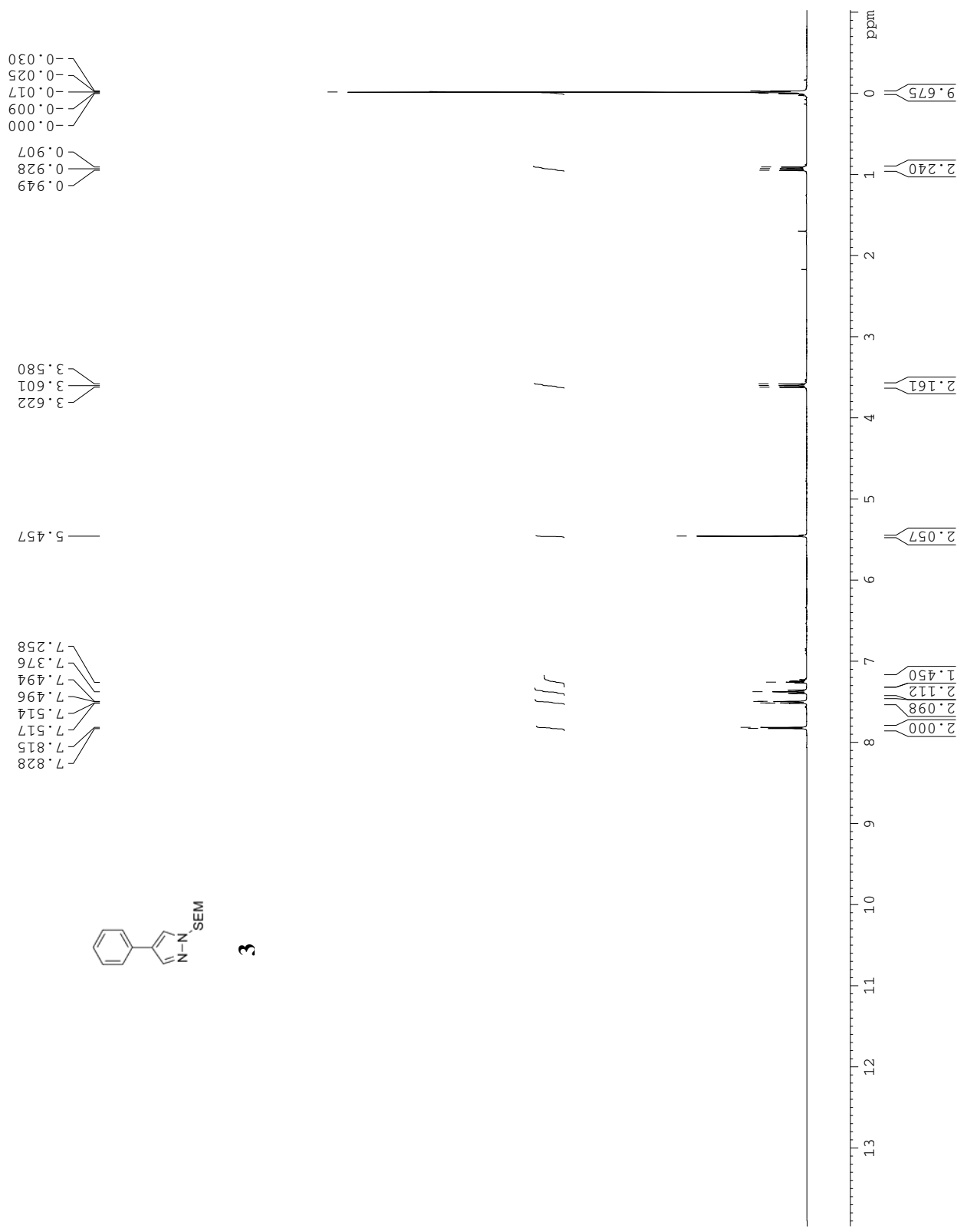

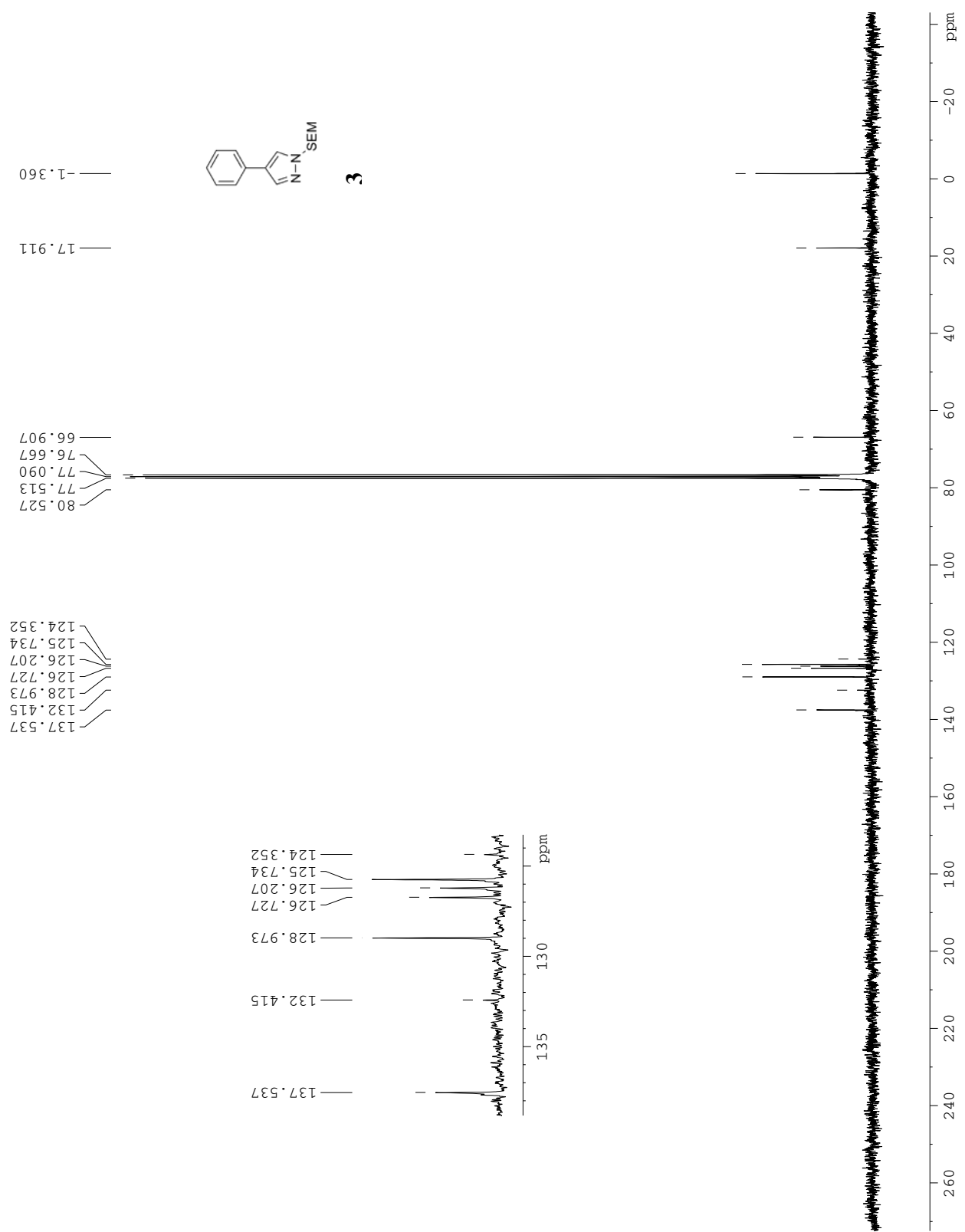

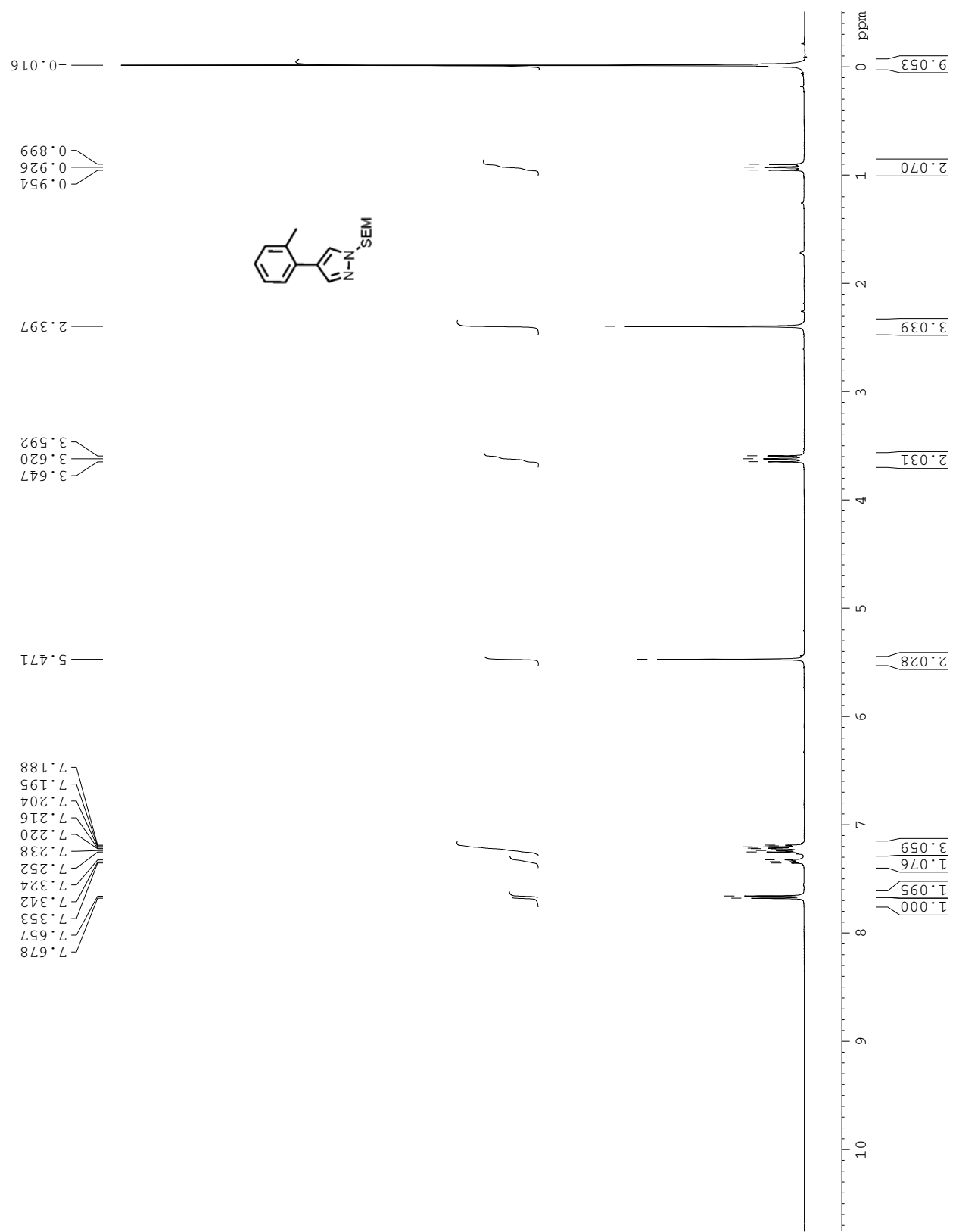

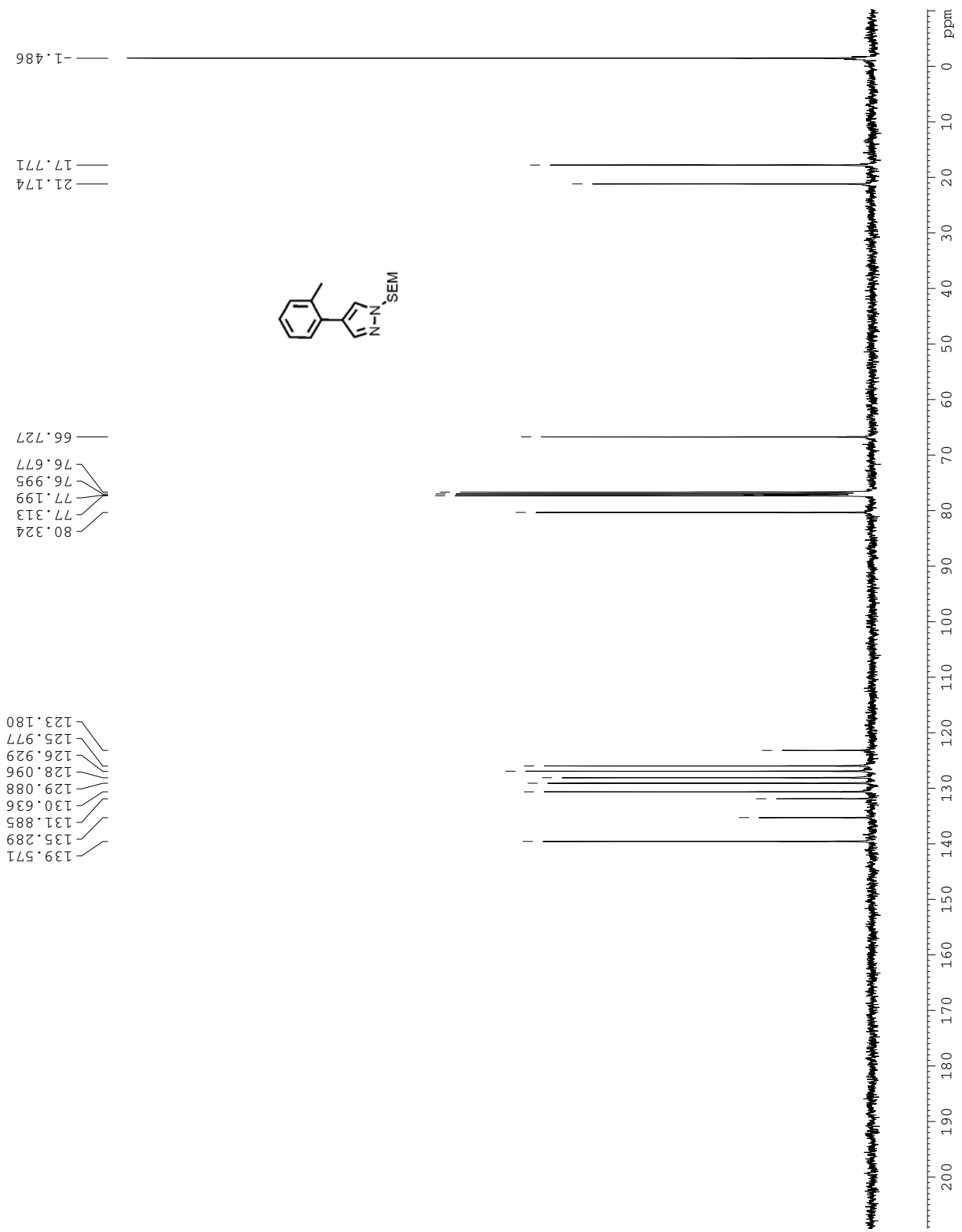

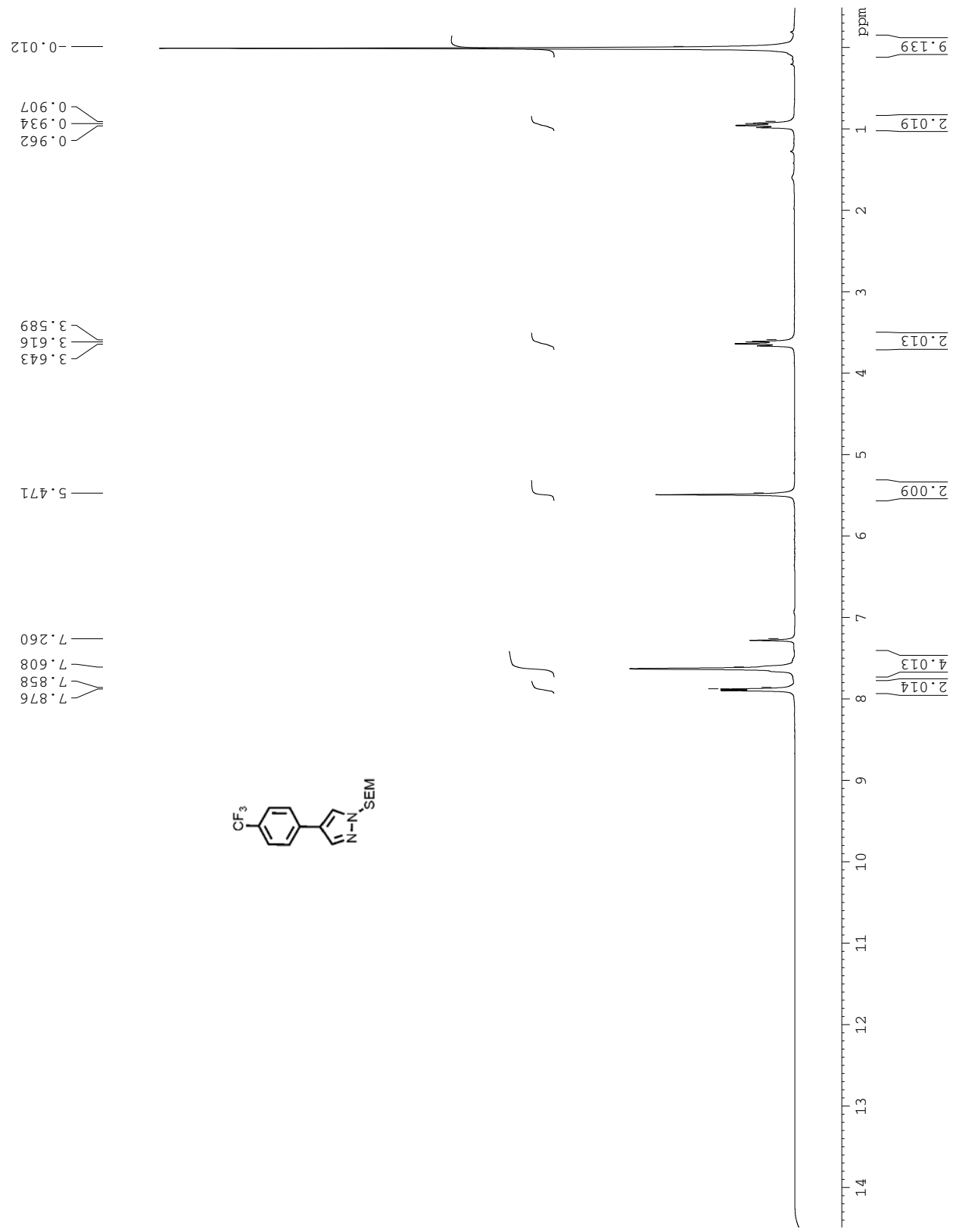



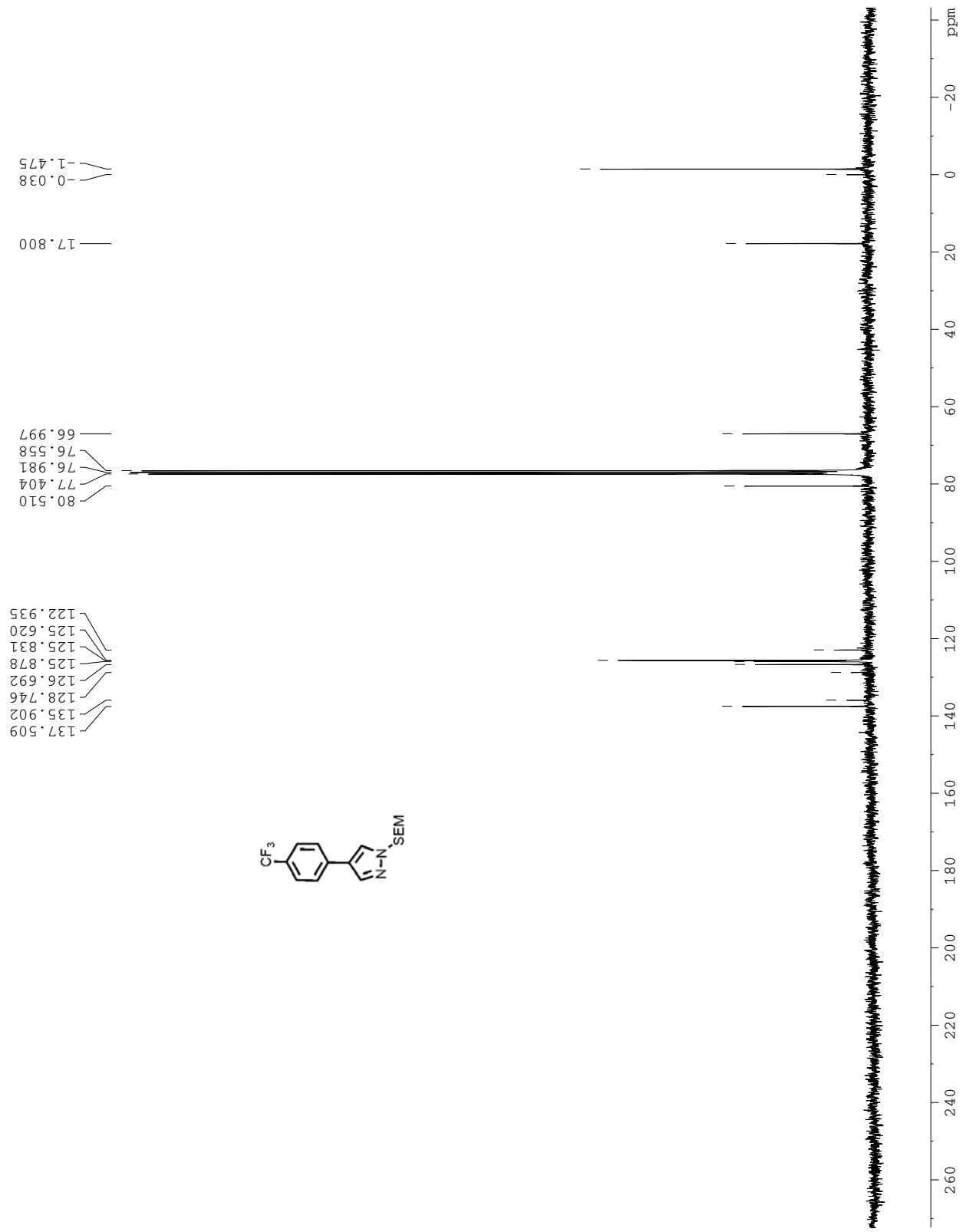

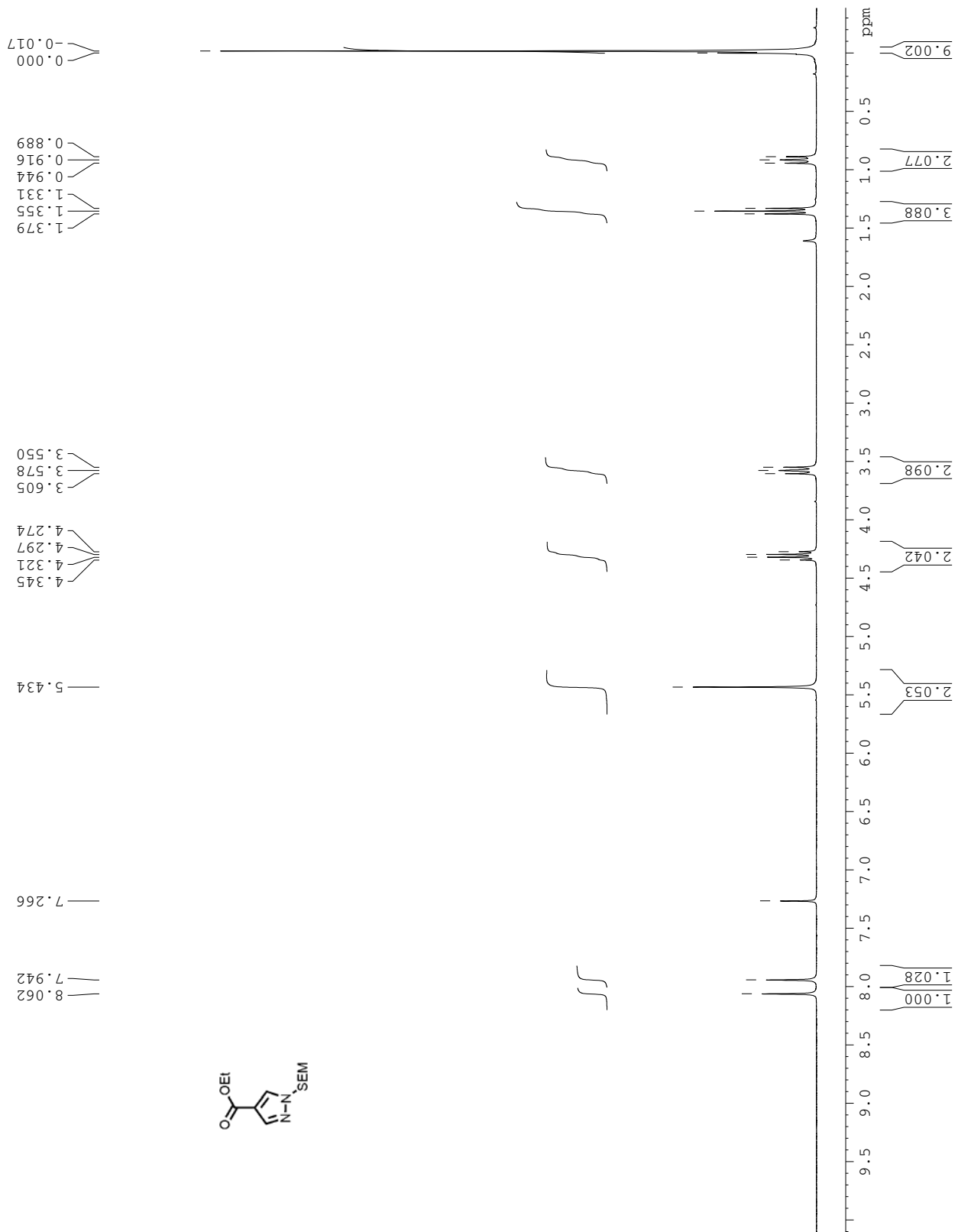

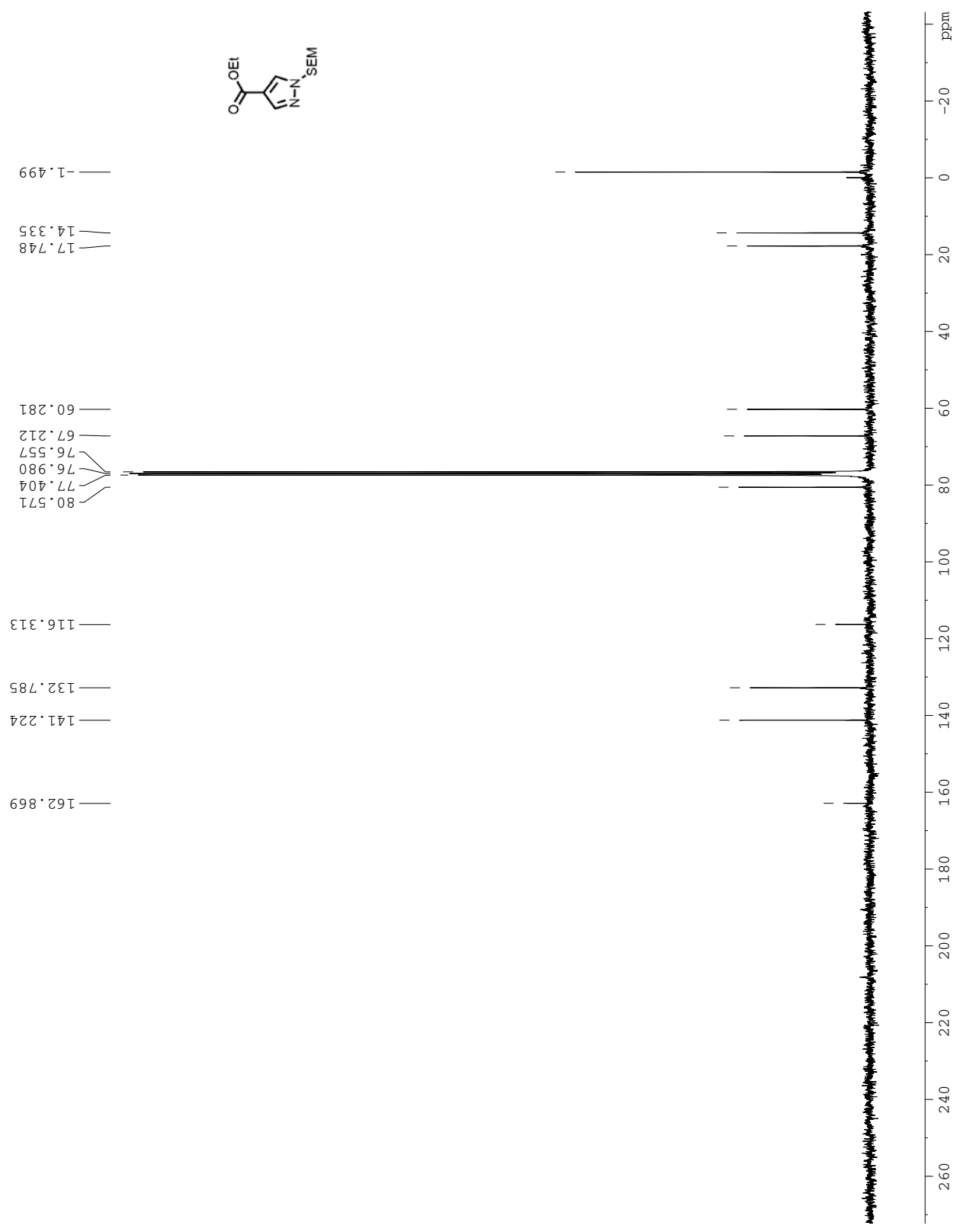

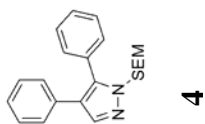
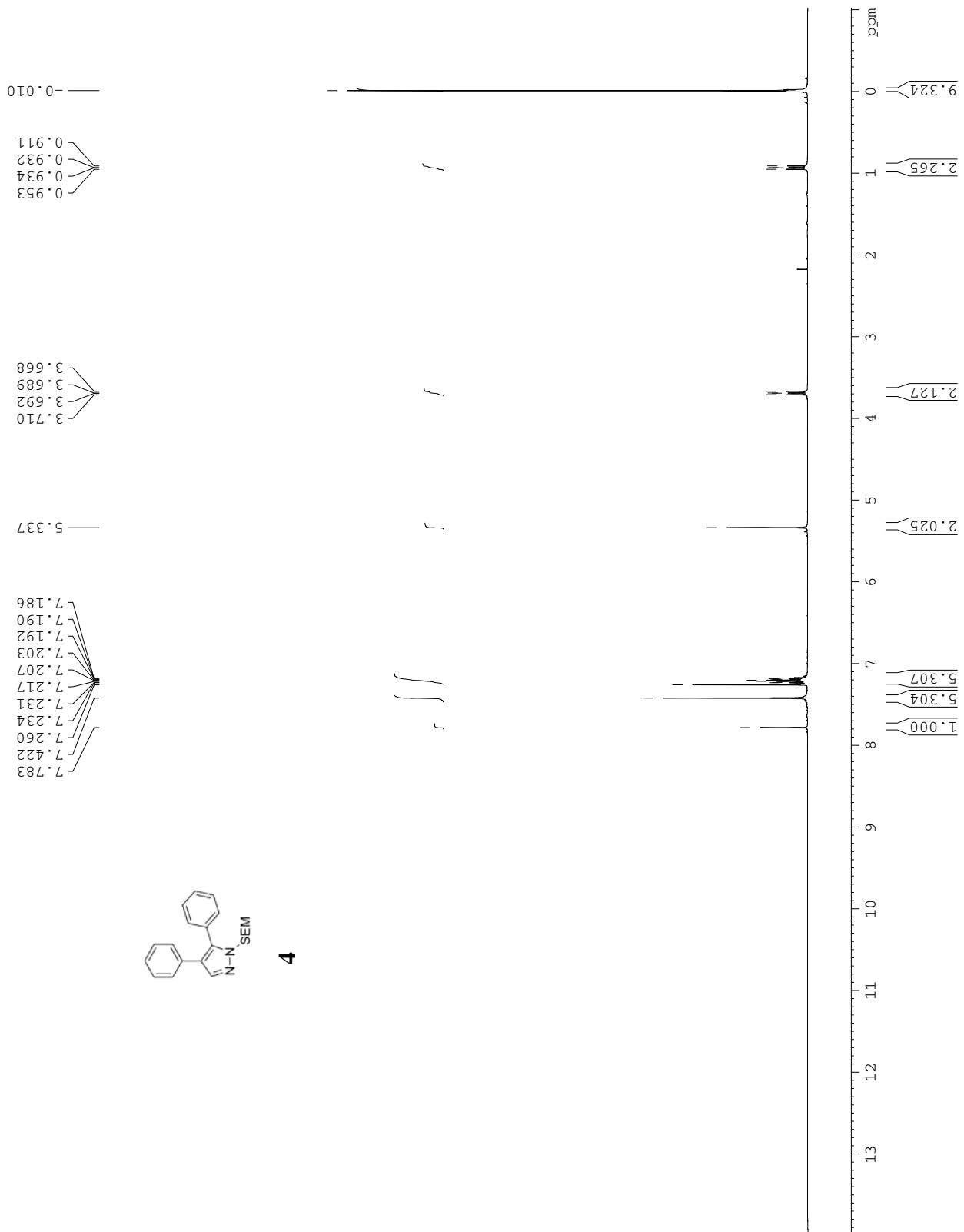

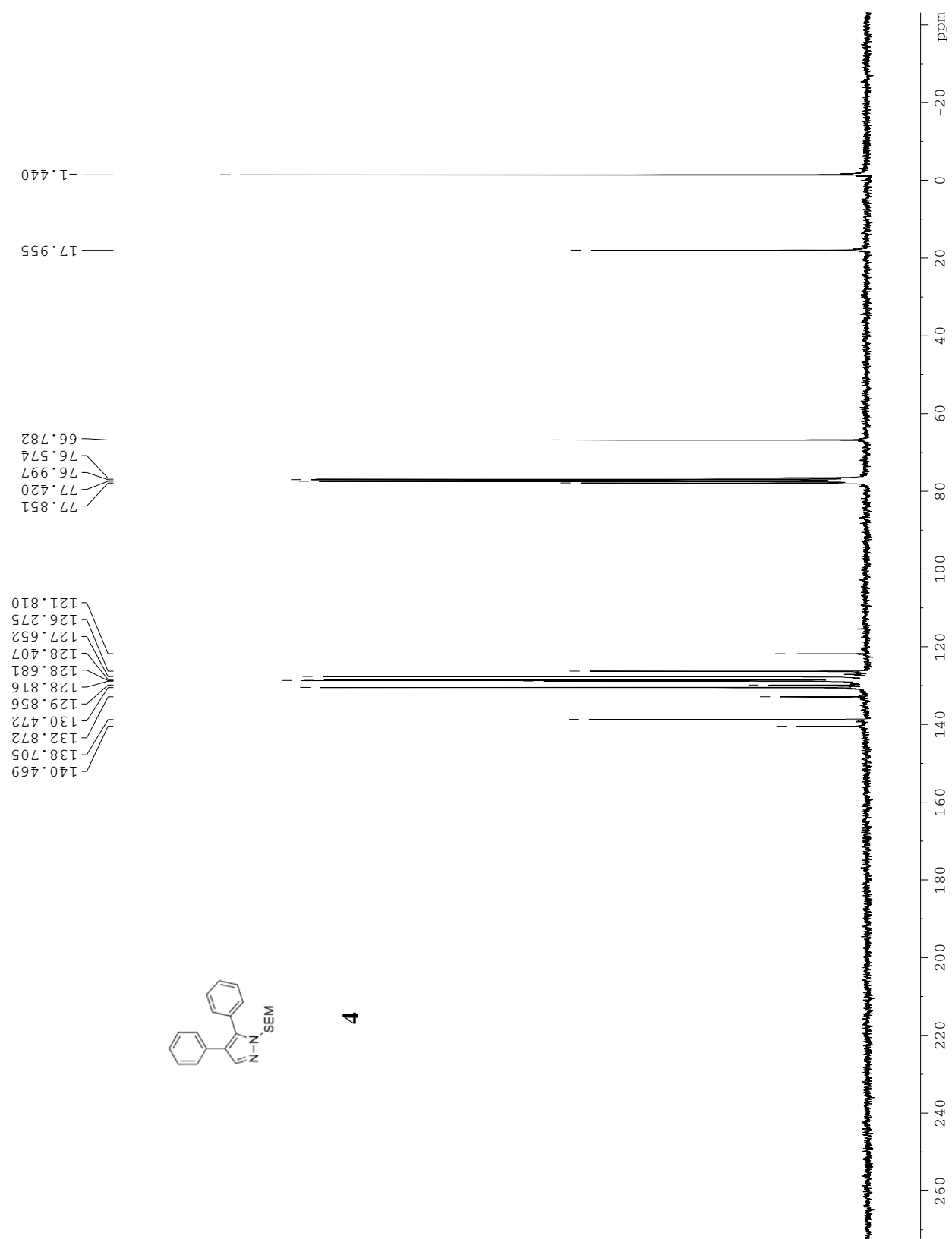

4

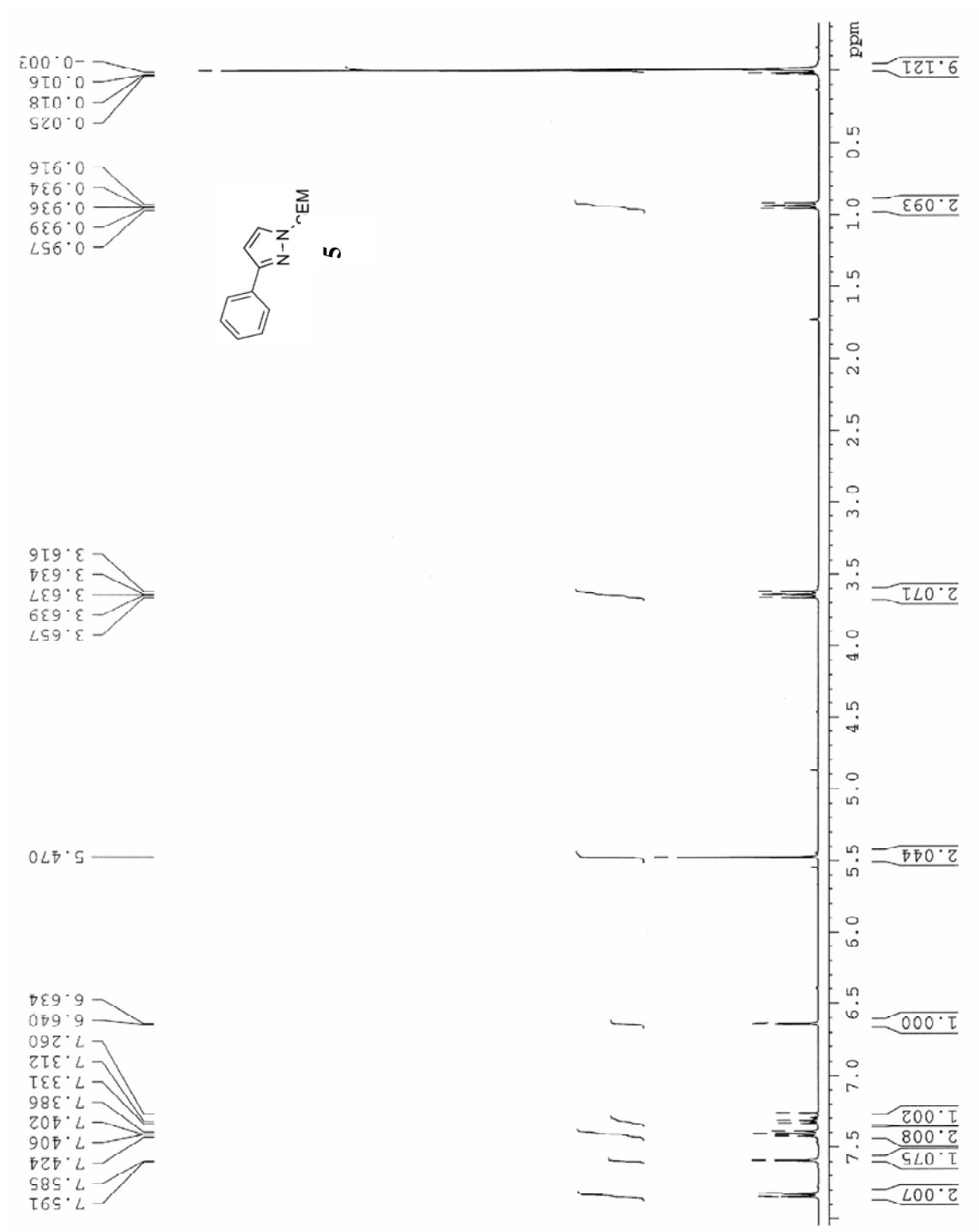

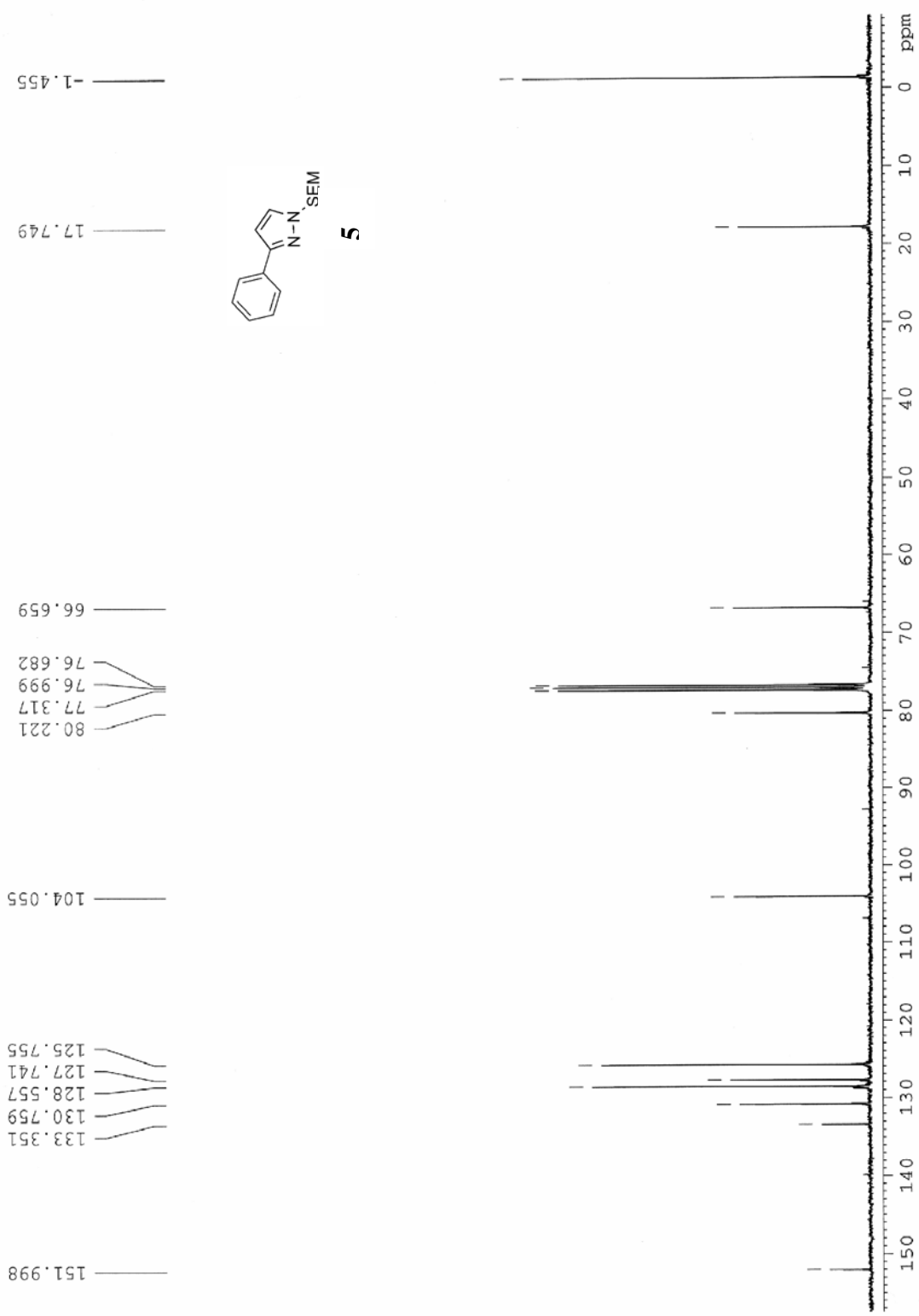

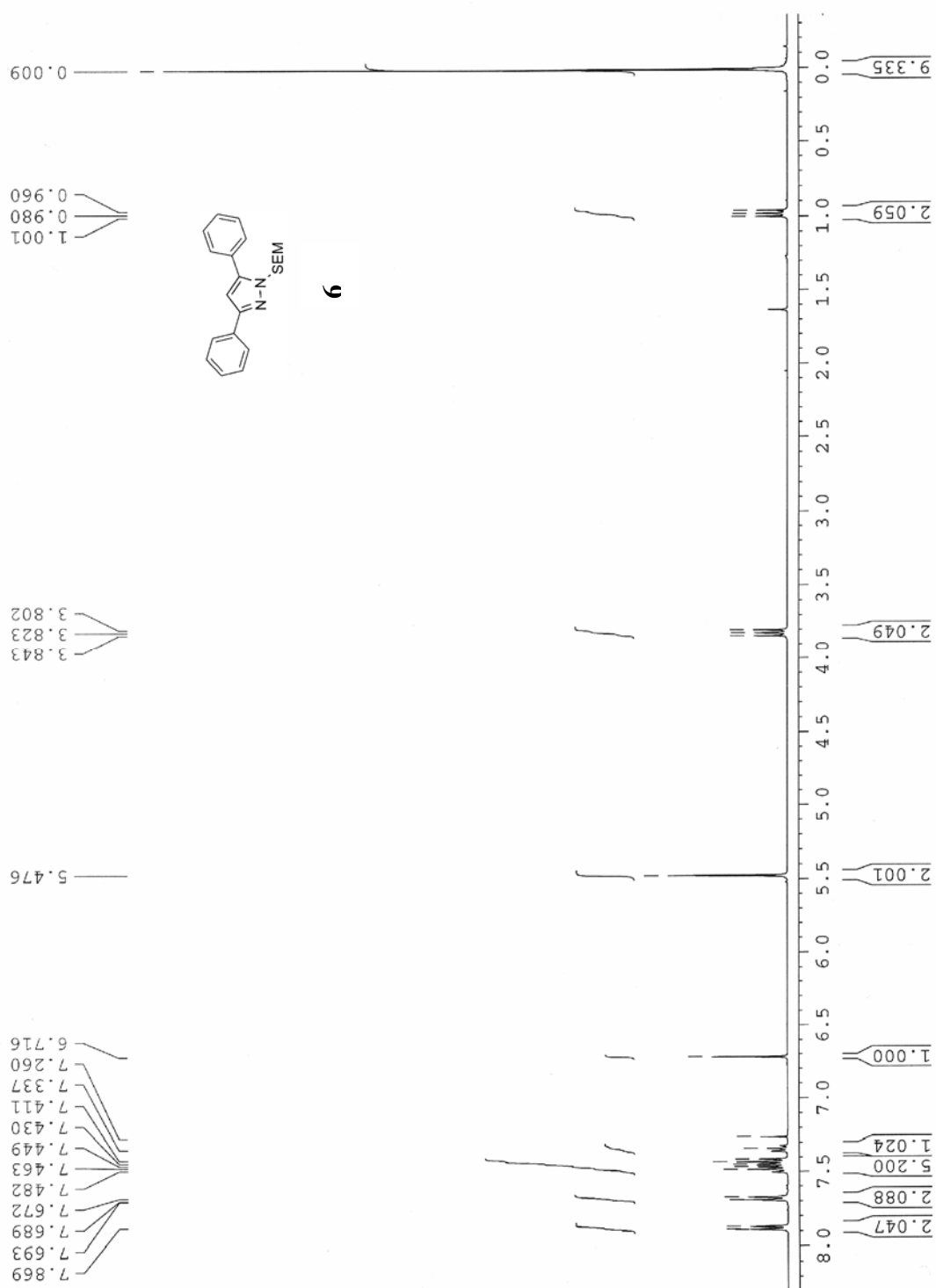



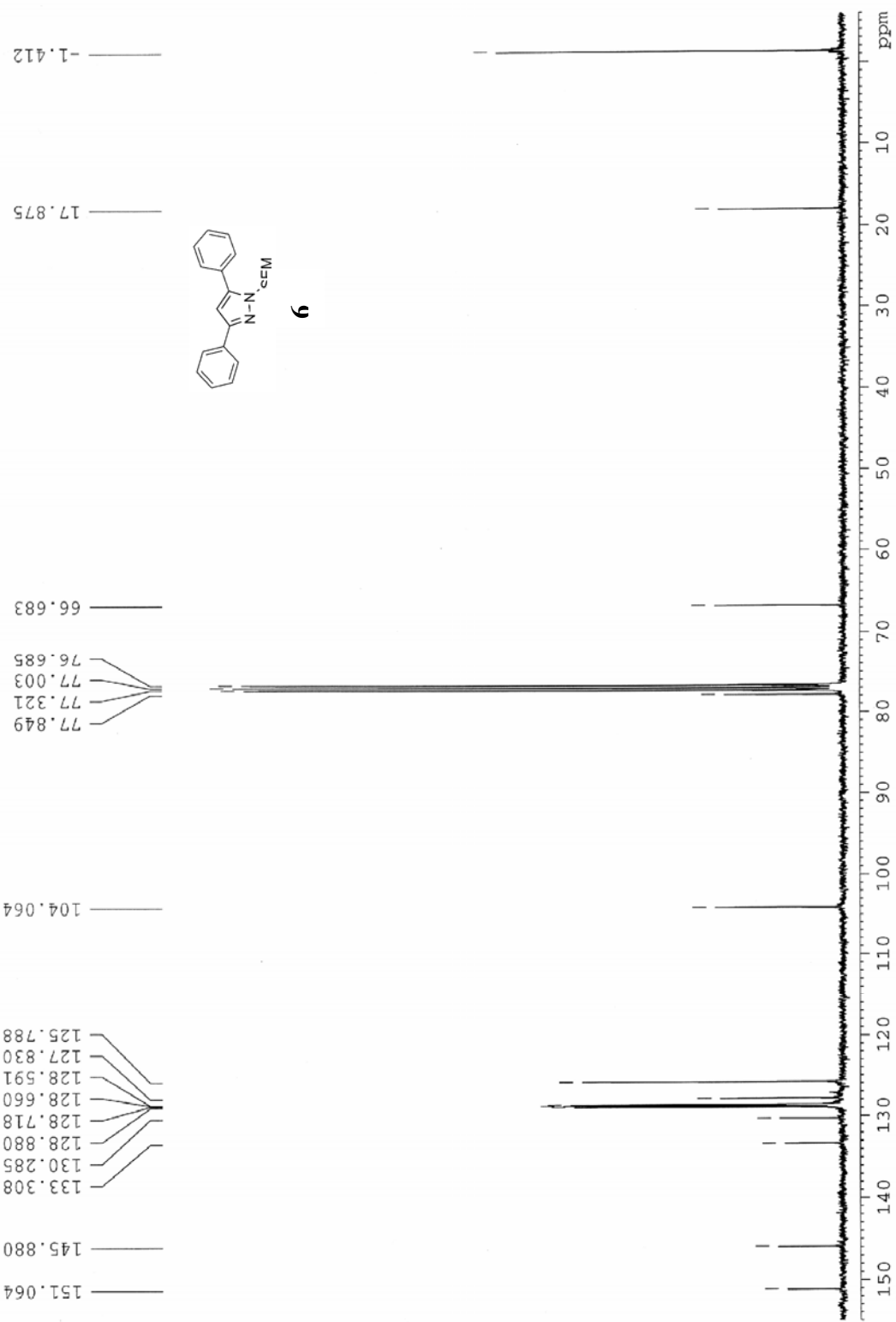

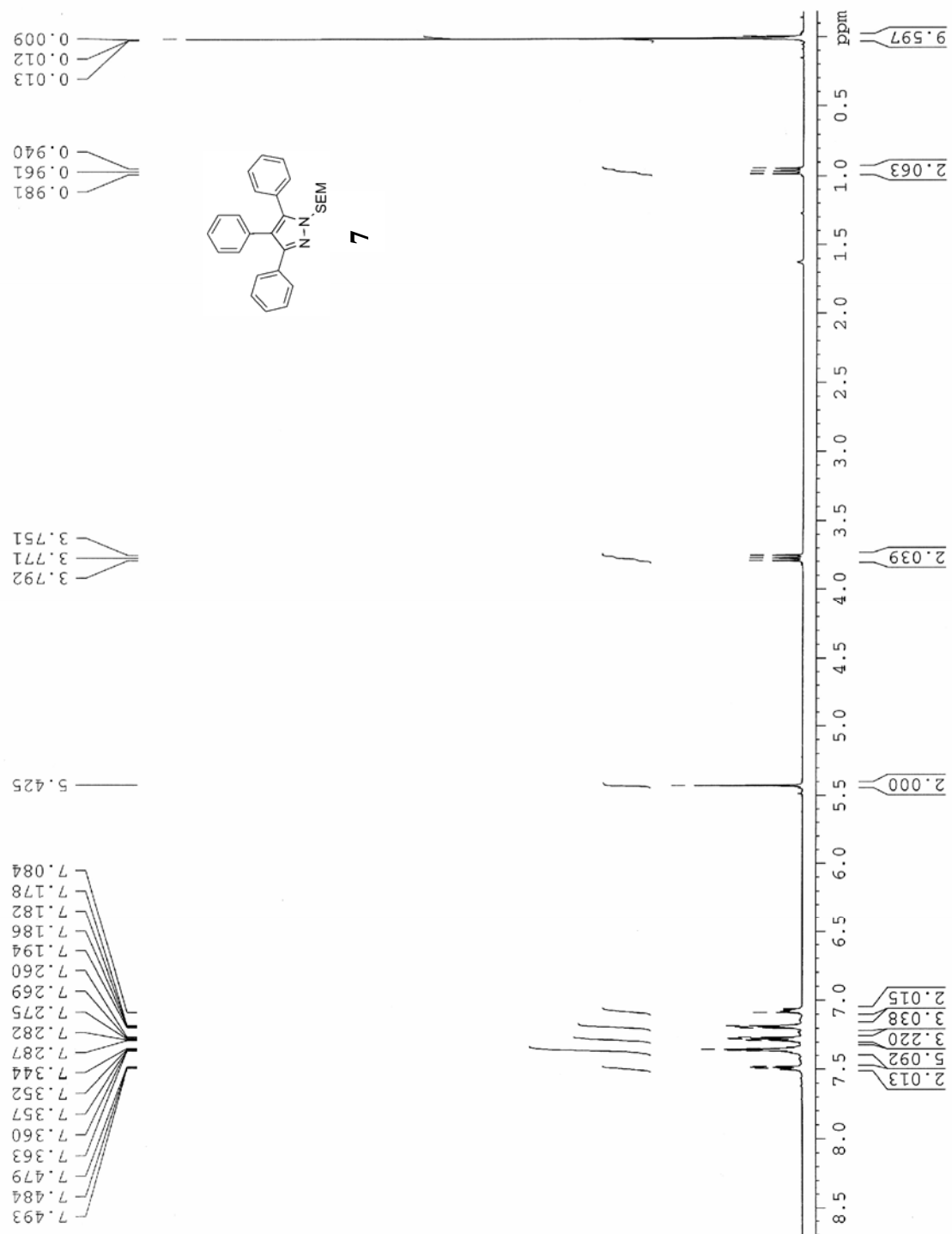

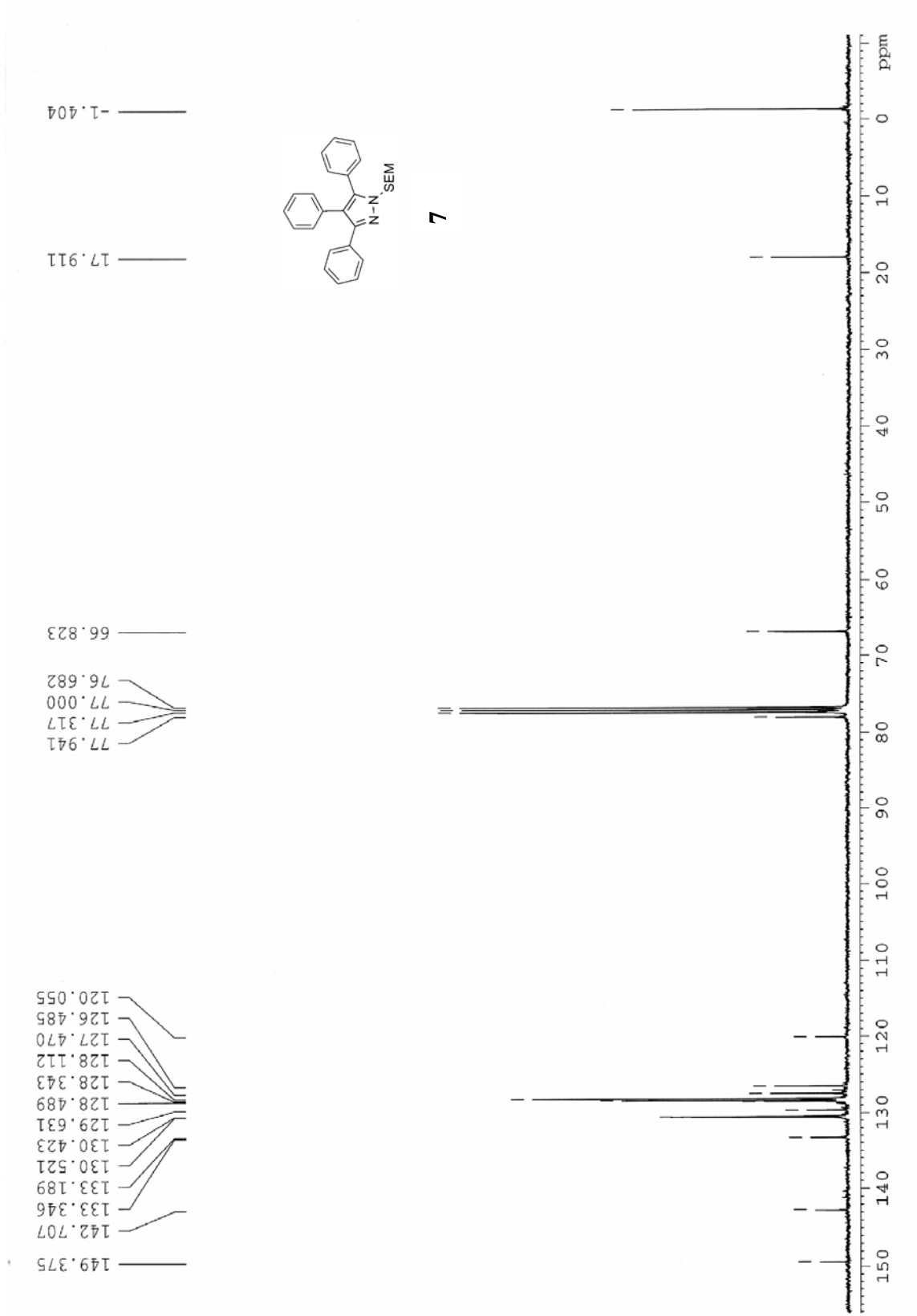

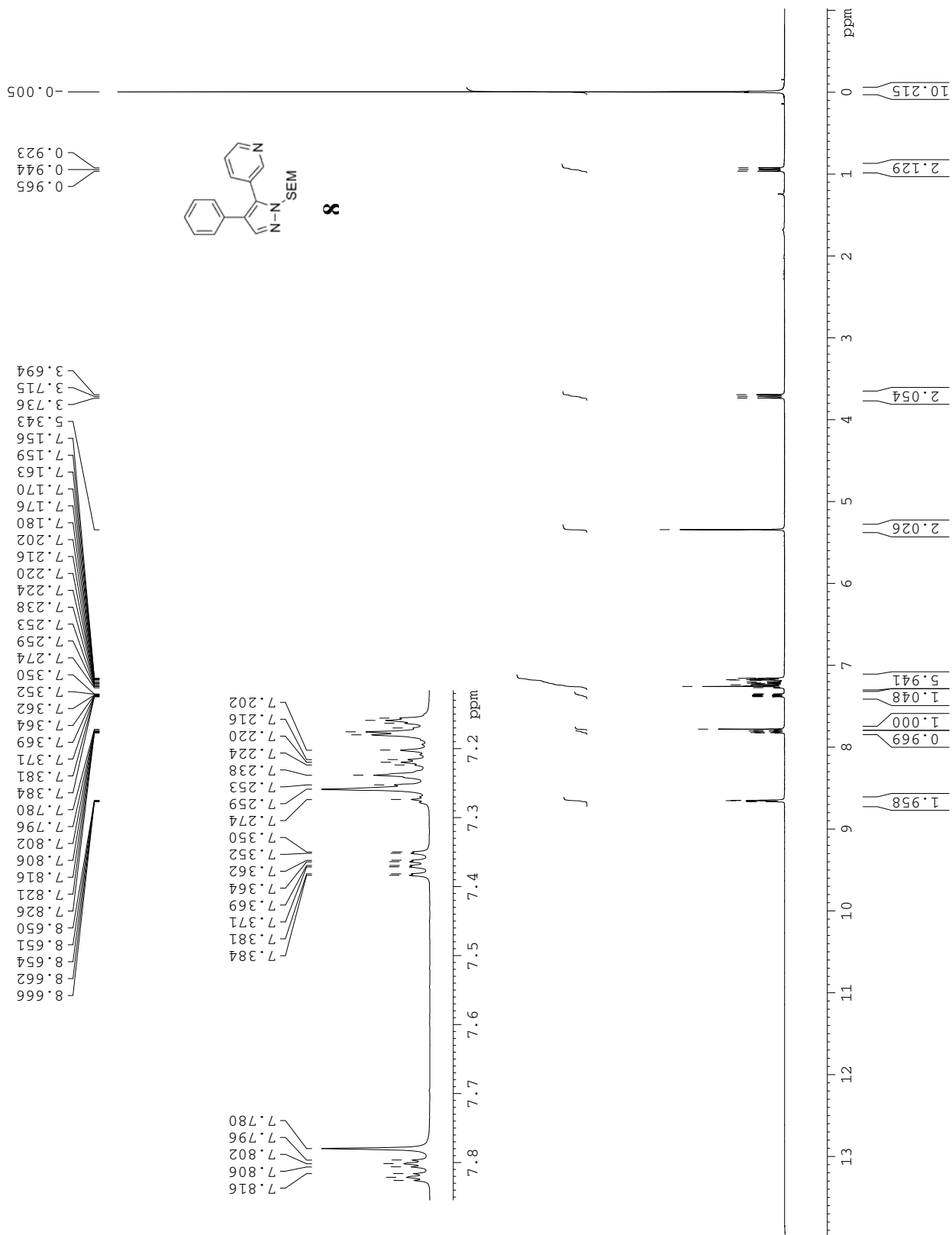

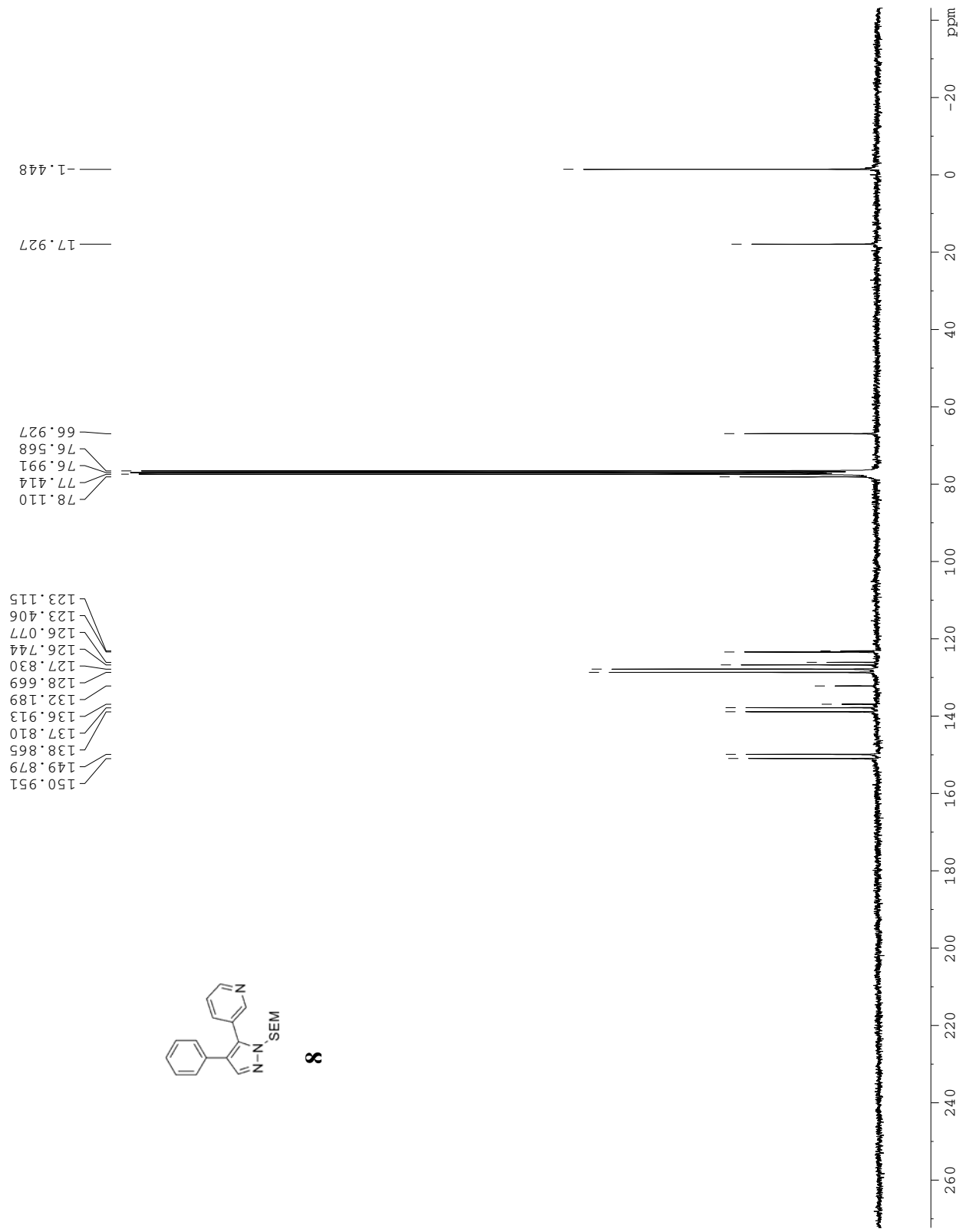

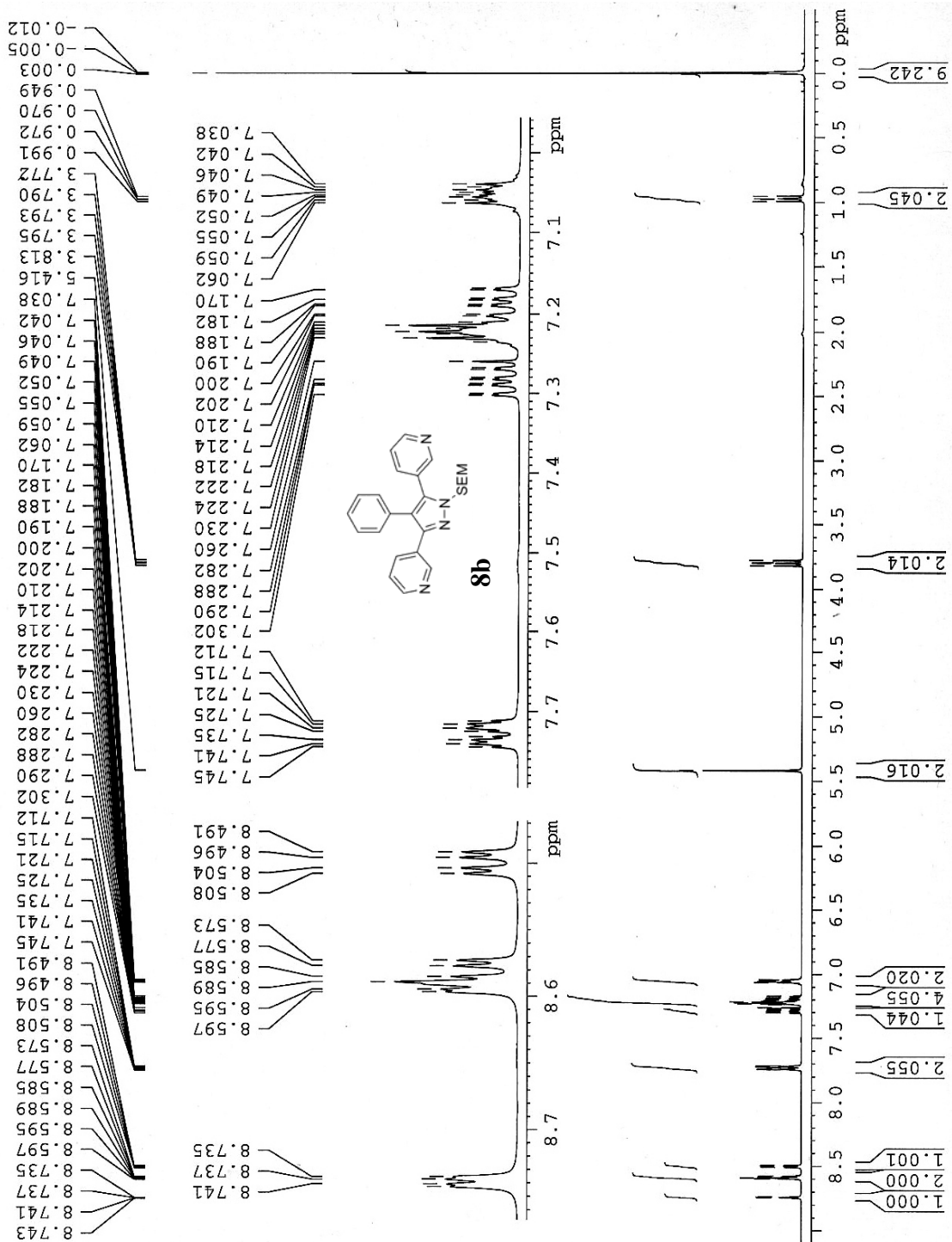

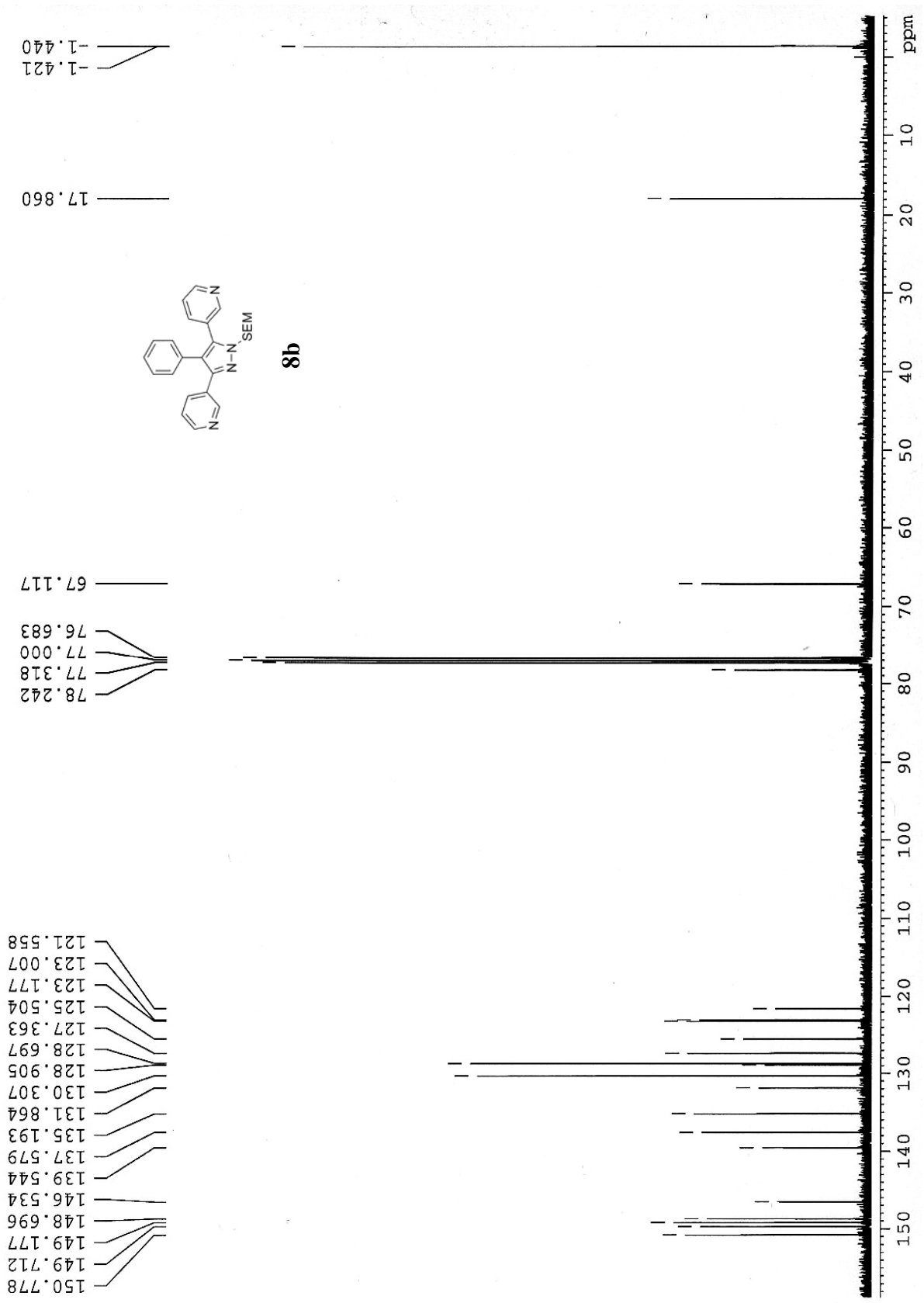

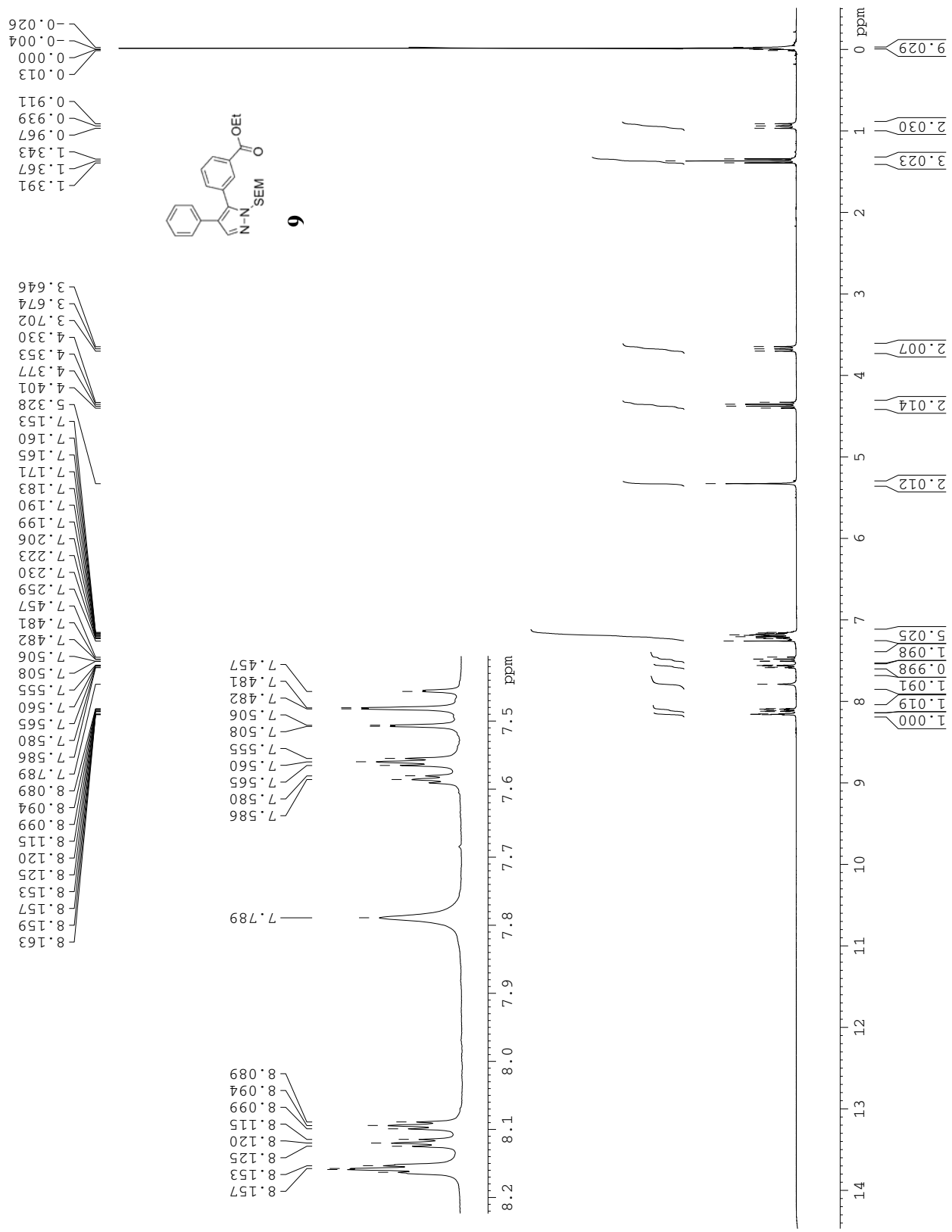



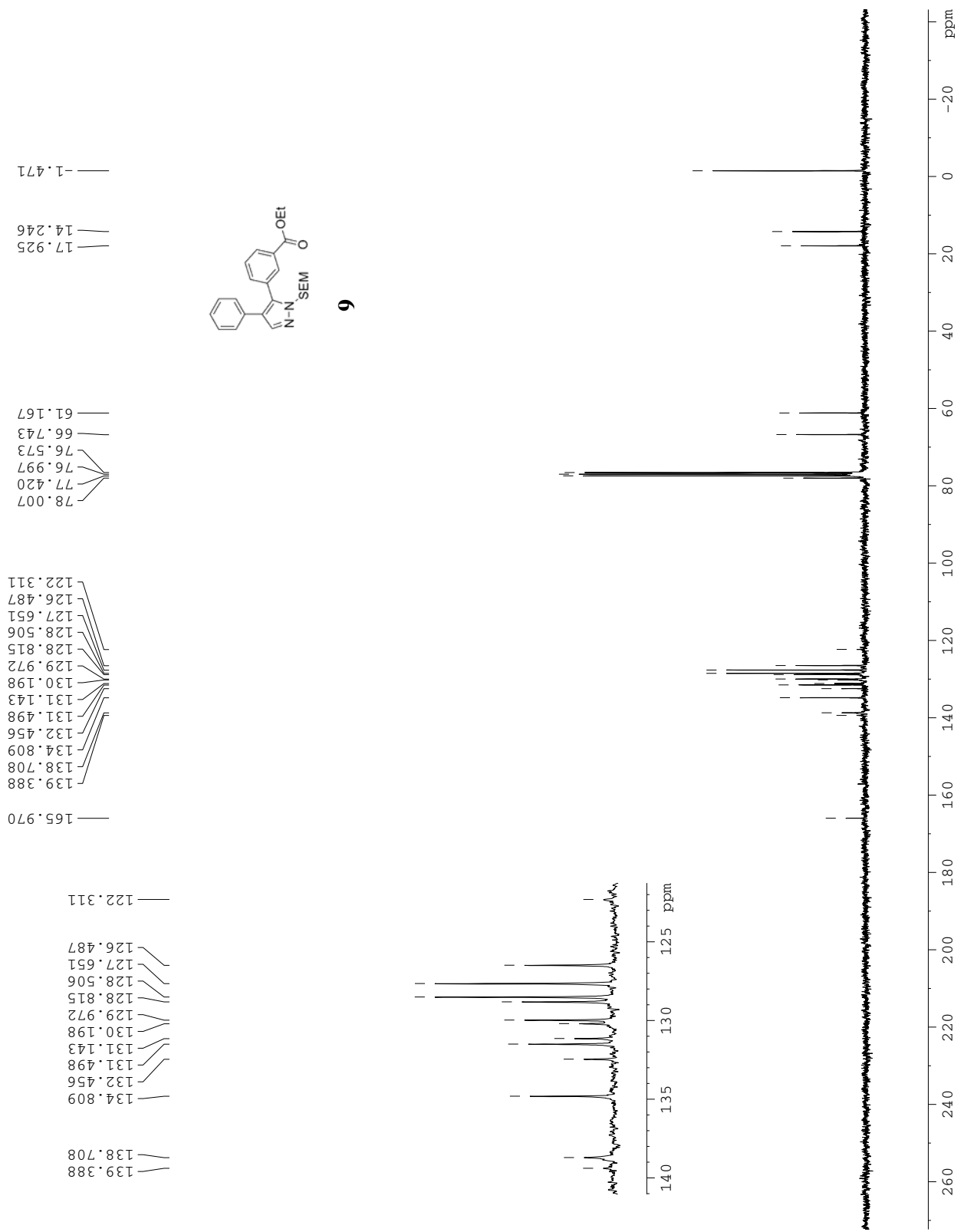

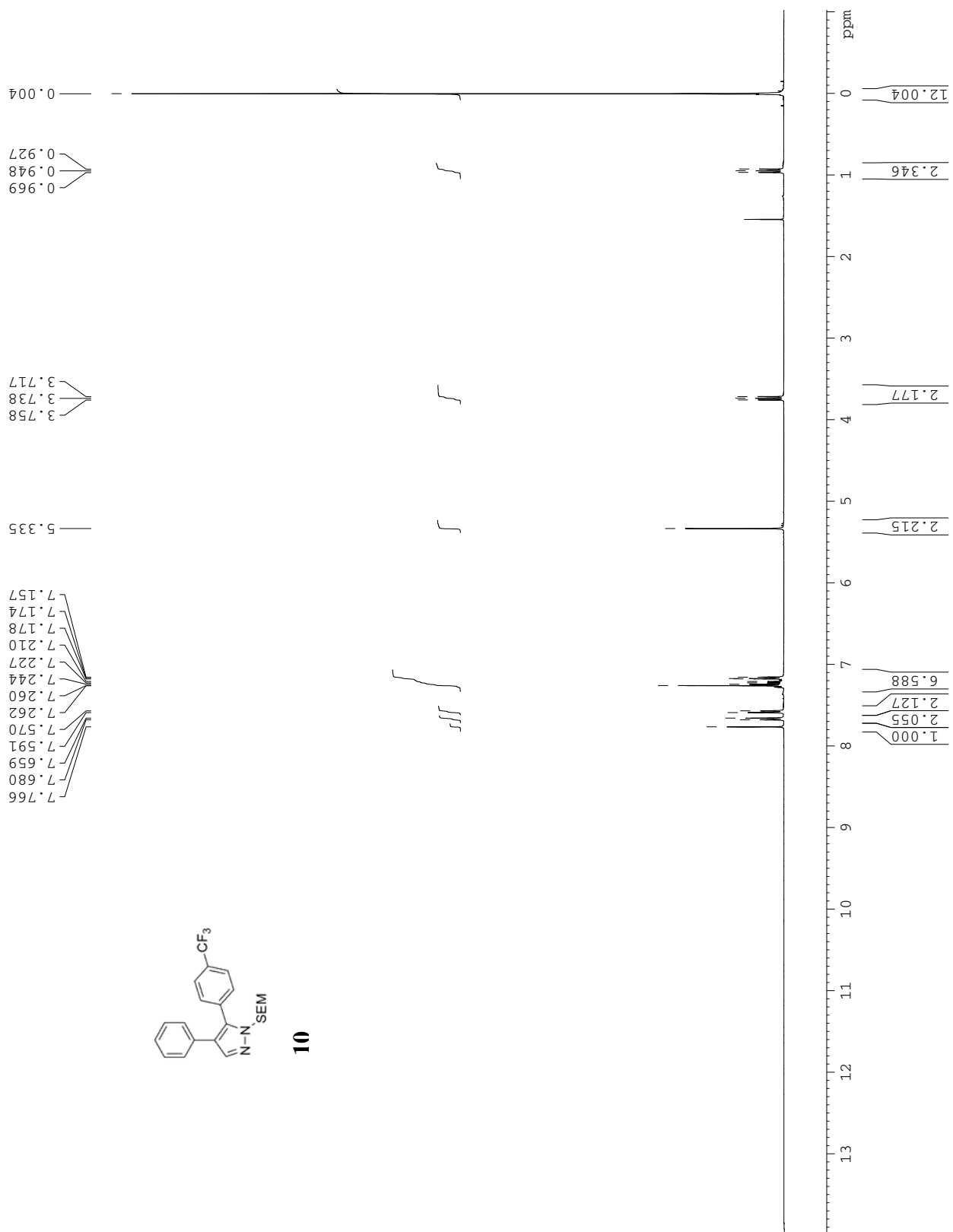

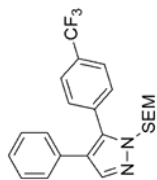

**10**

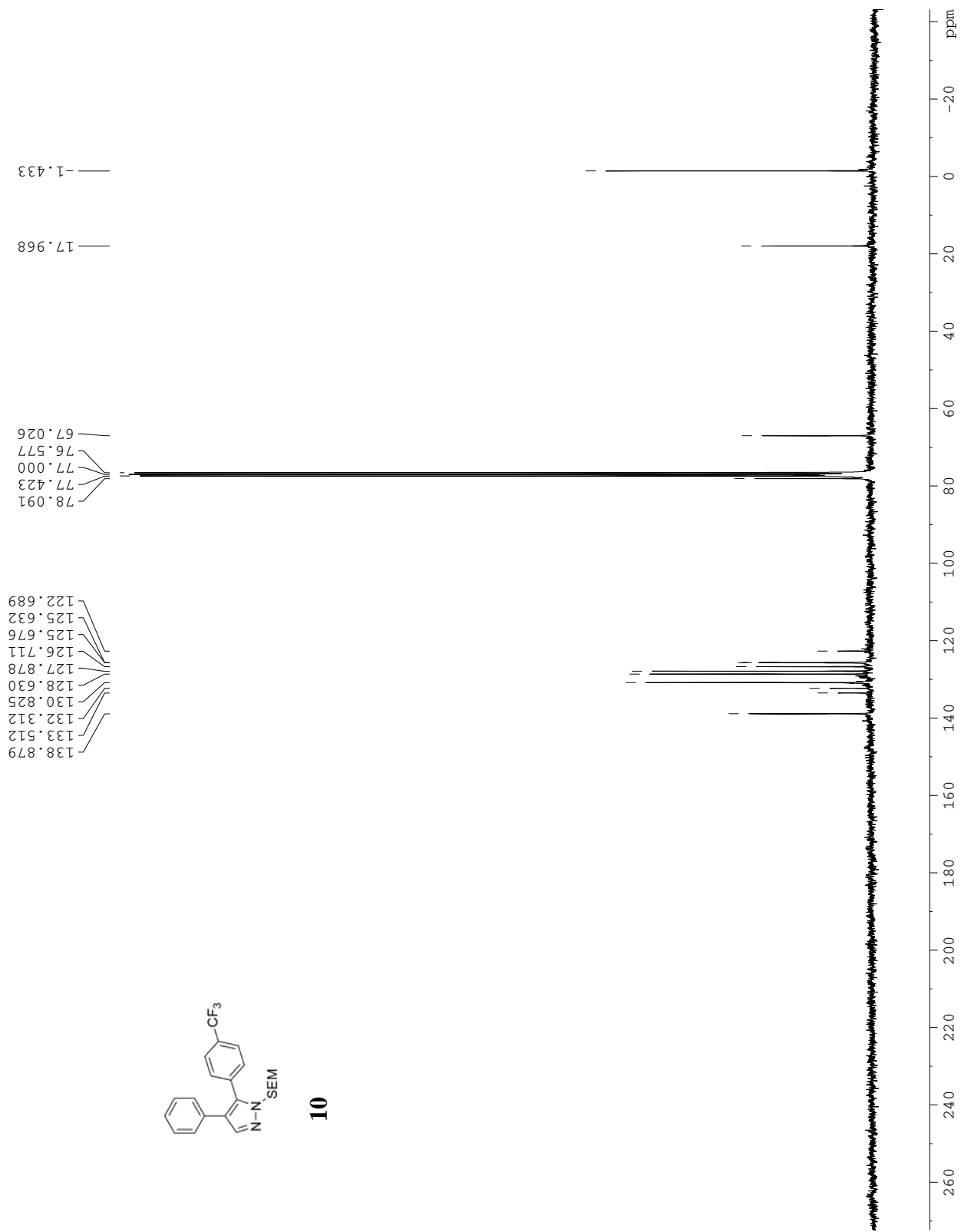

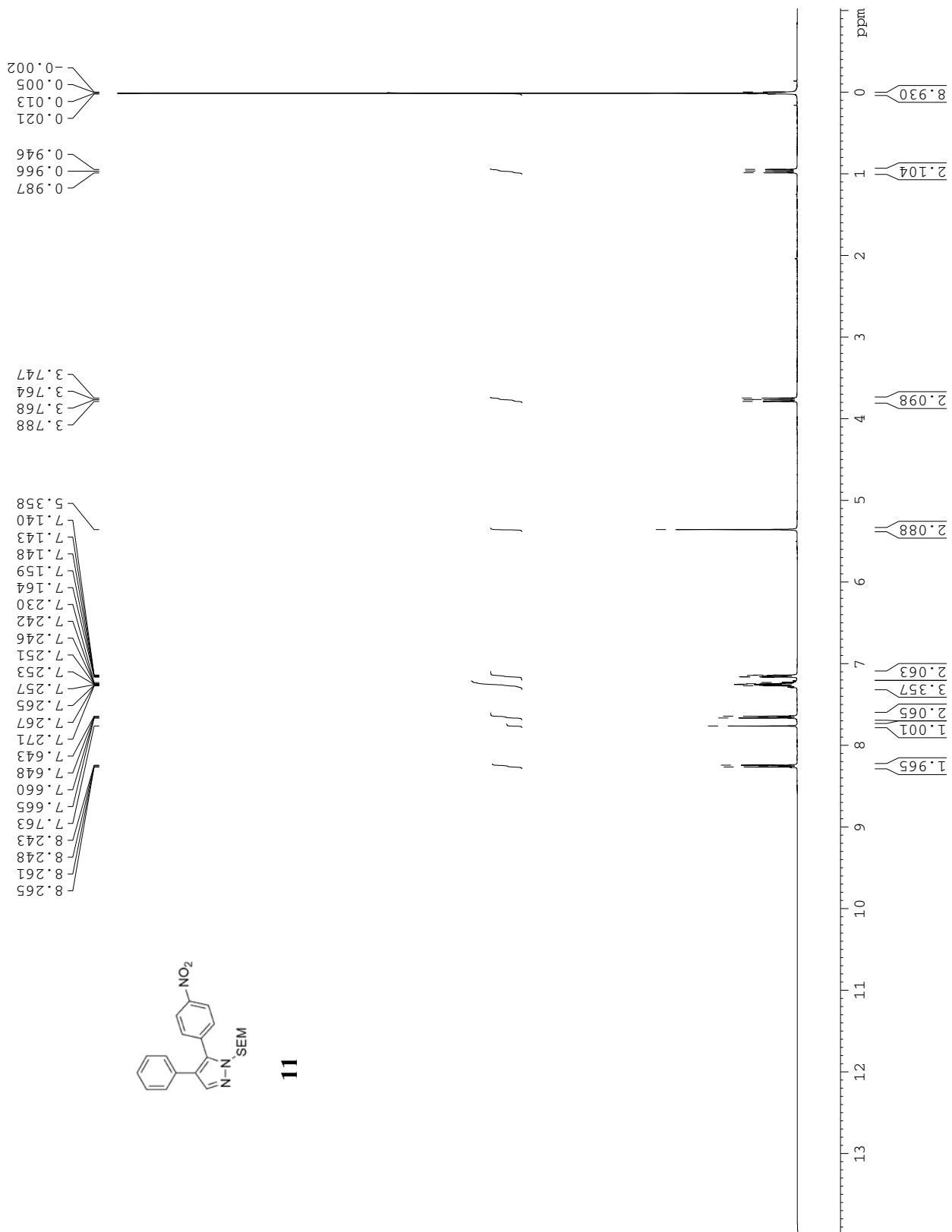

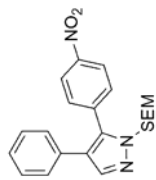

11

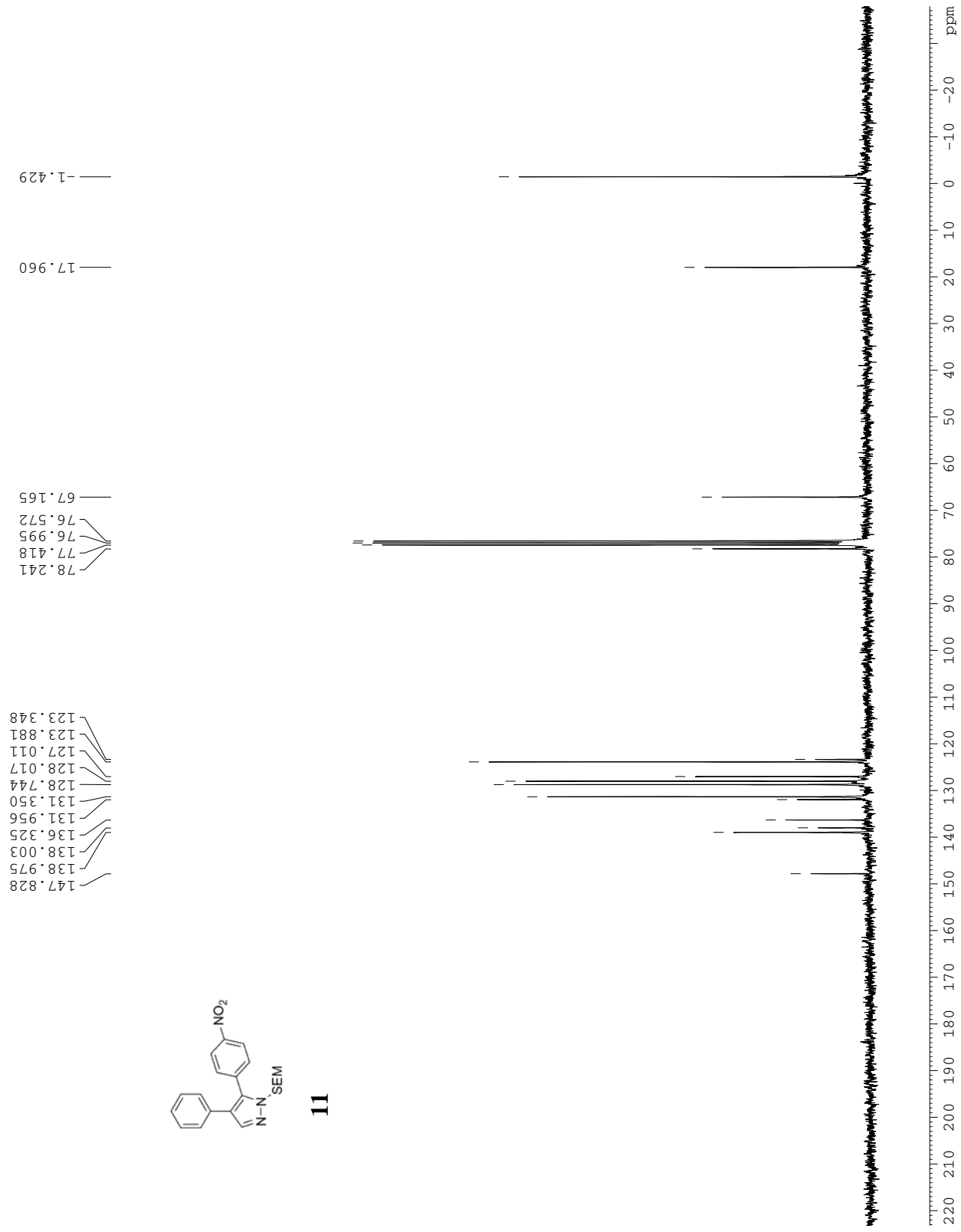

TLJ-1-247 1H 400MHz CDC  
after HPLC purificatio.

0.989  
0.968  
0.947

3.784  
3.750  
3.730  
3.709

5.383

7.809  
7.374  
7.354  
7.334  
7.295  
7.274  
7.259  
7.222  
7.207  
7.042  
7.023  
7.005  
6.984

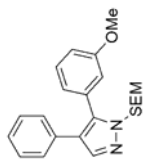

12

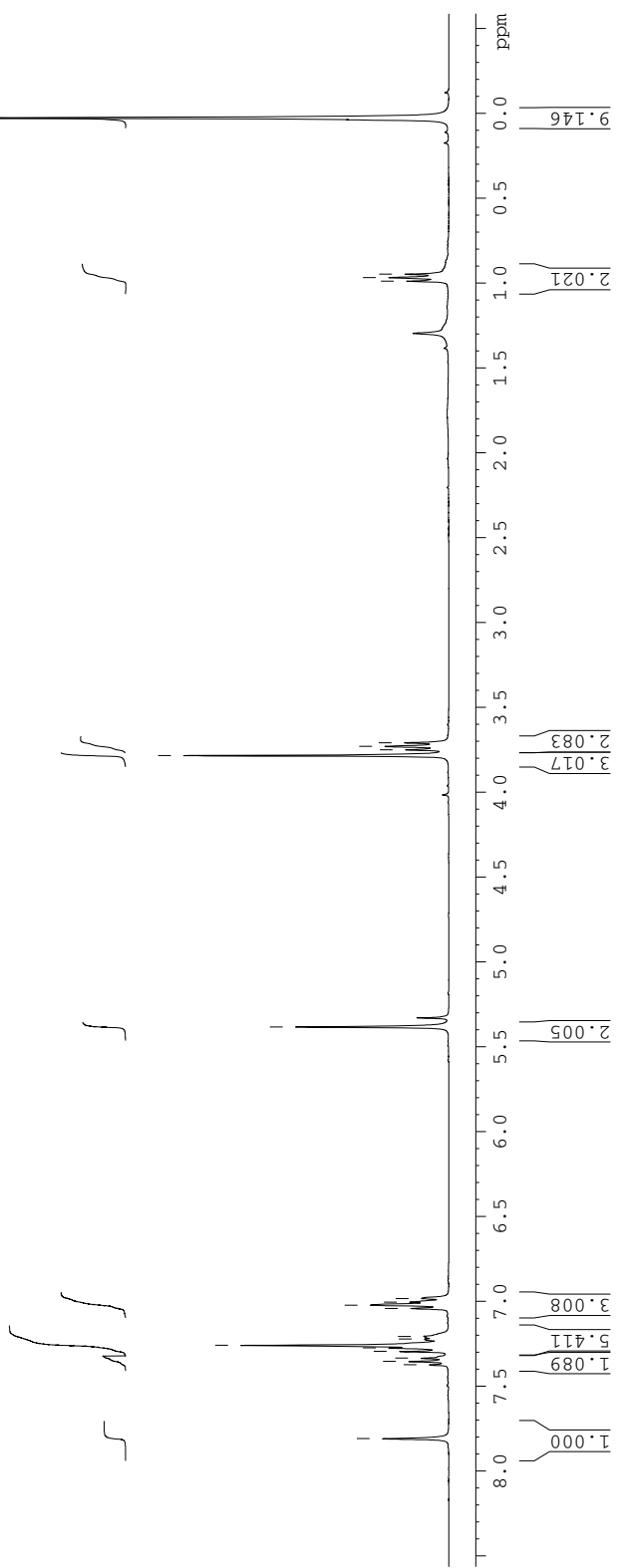

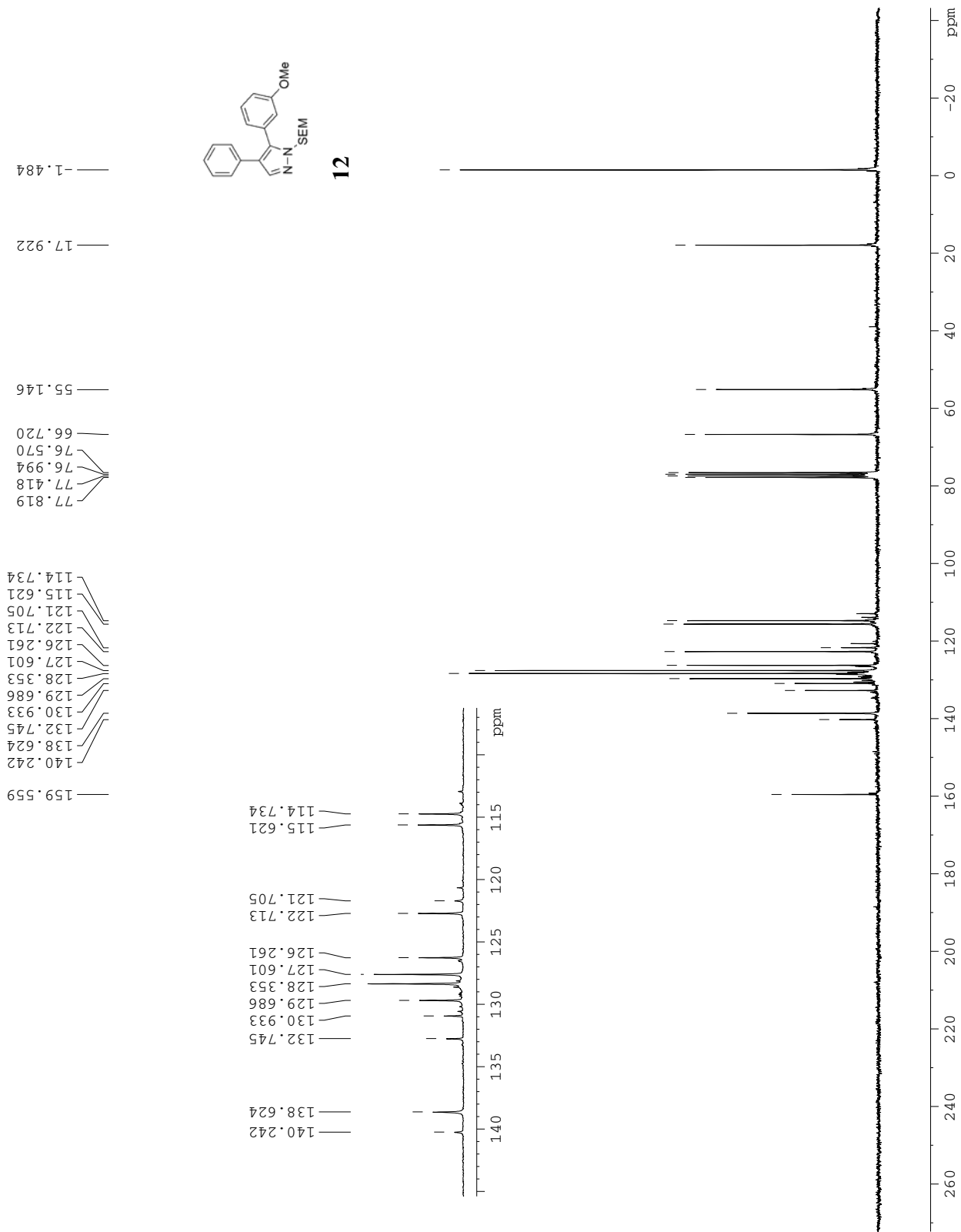

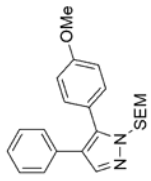
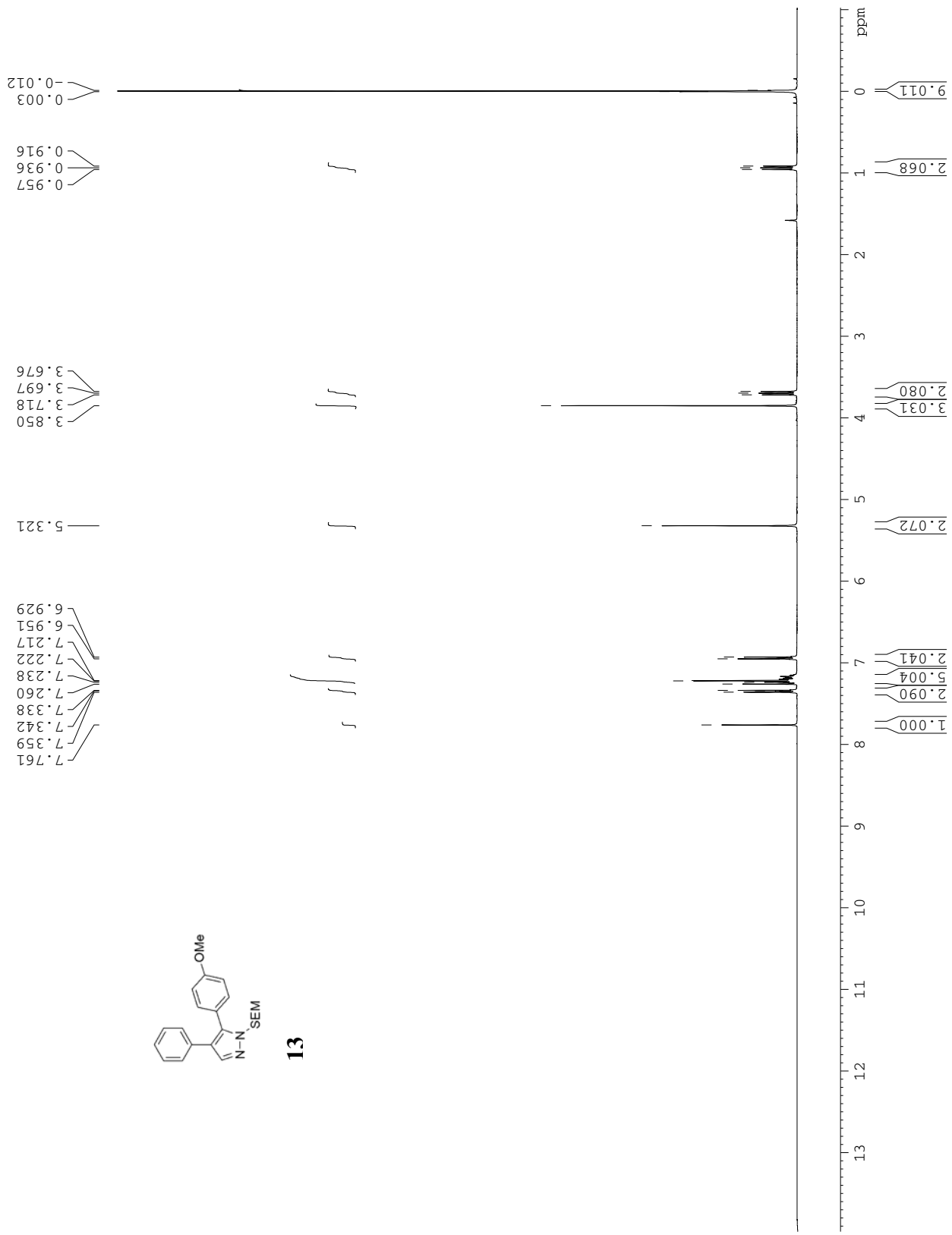

13



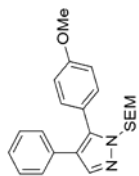

13

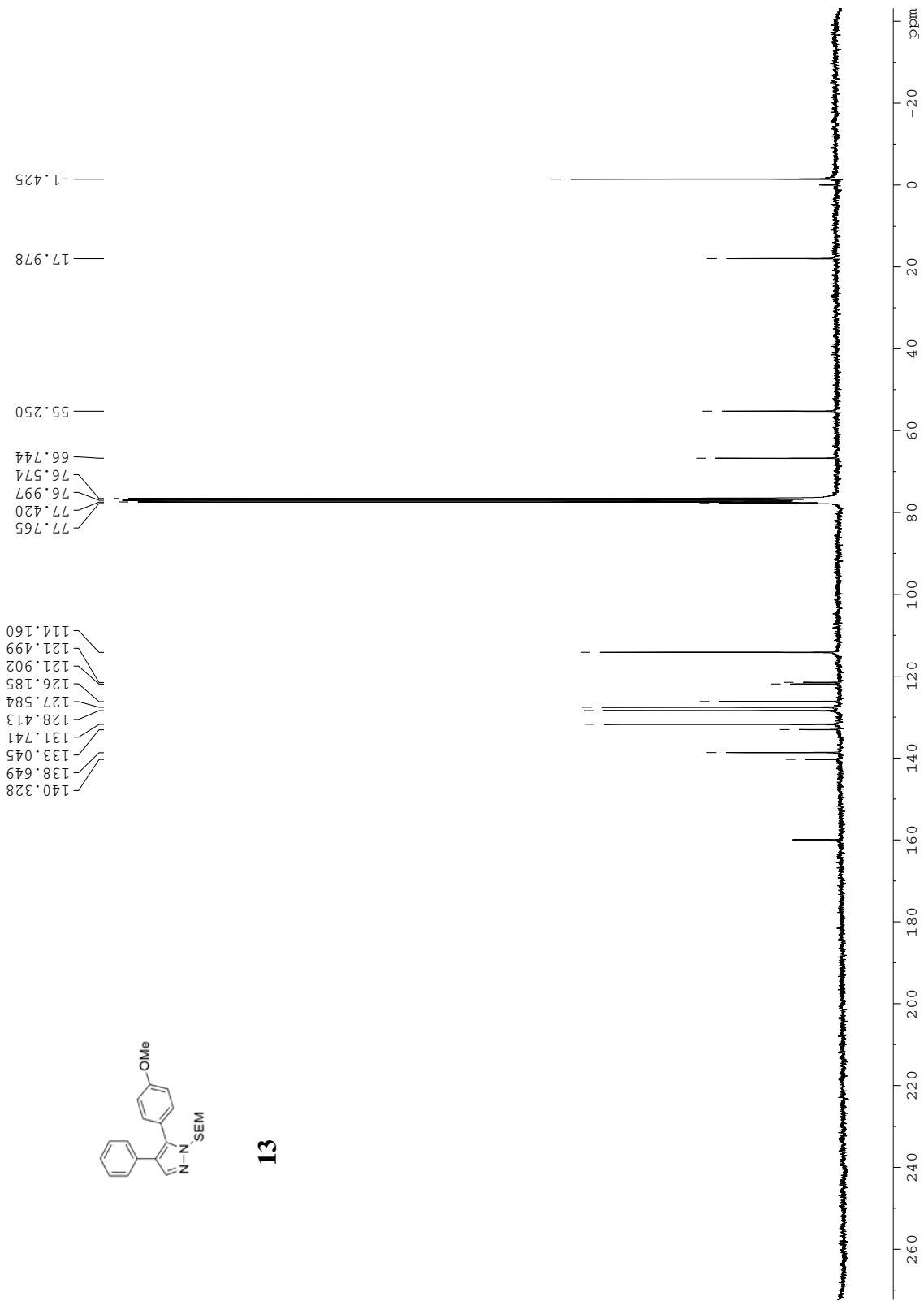

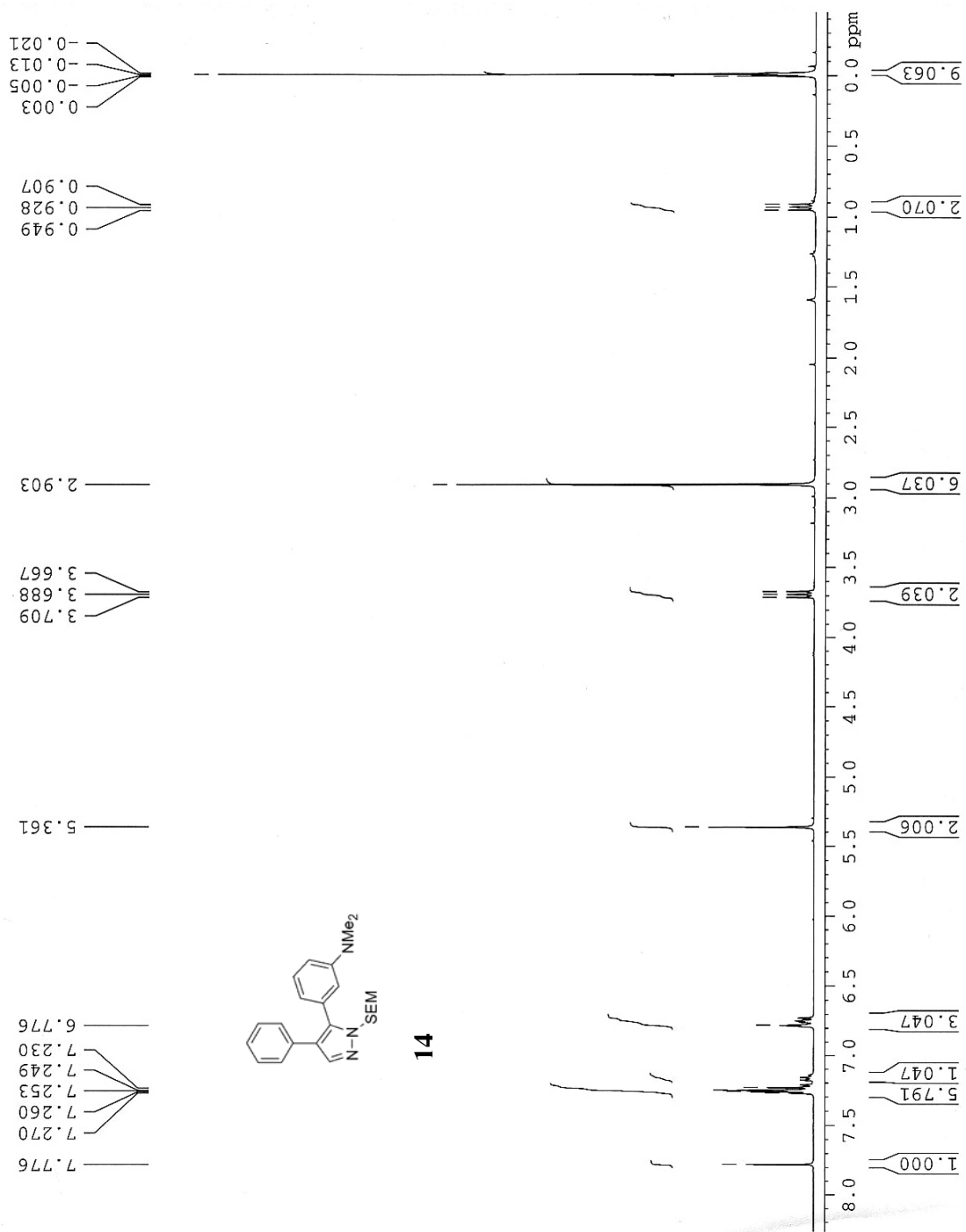

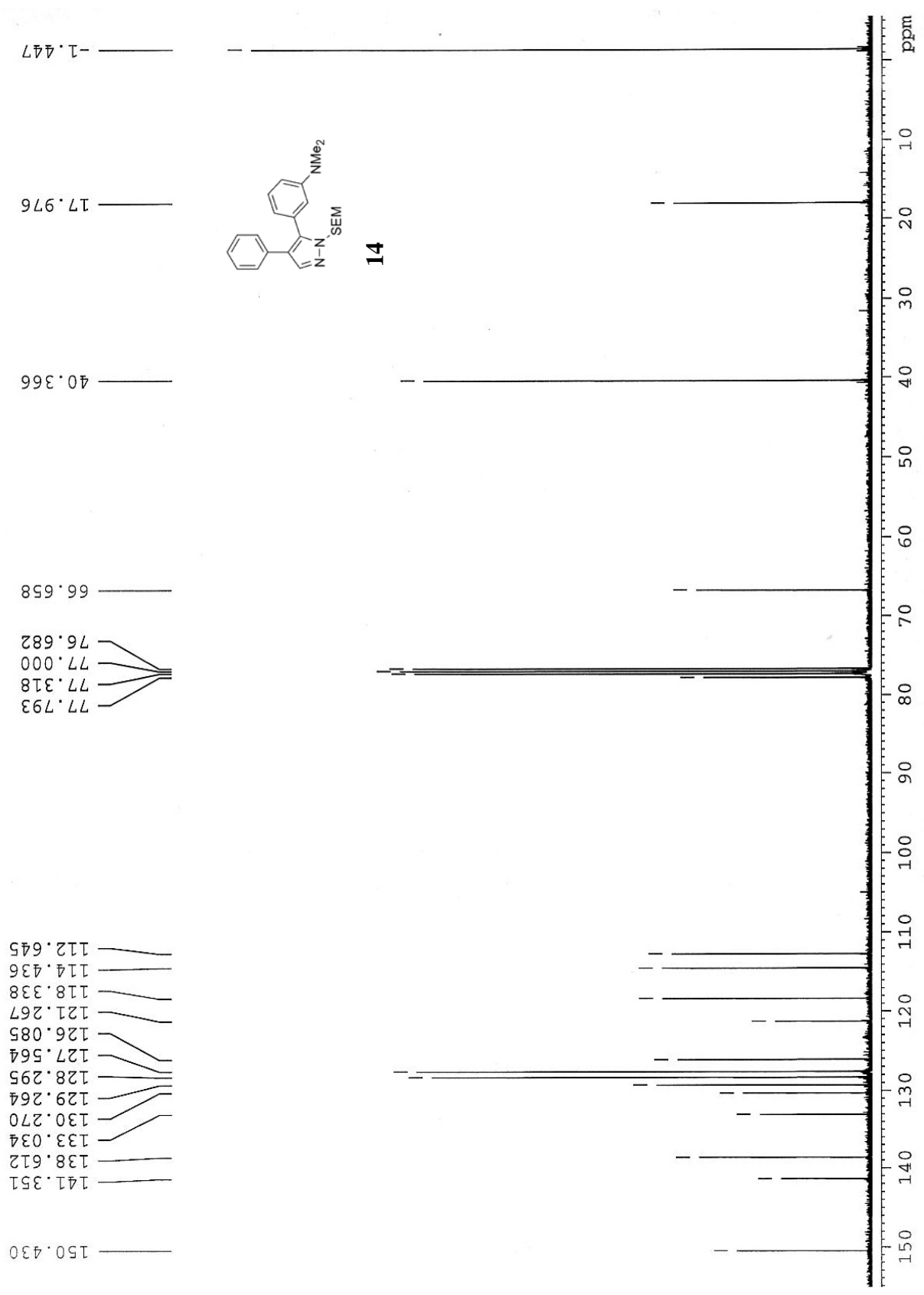

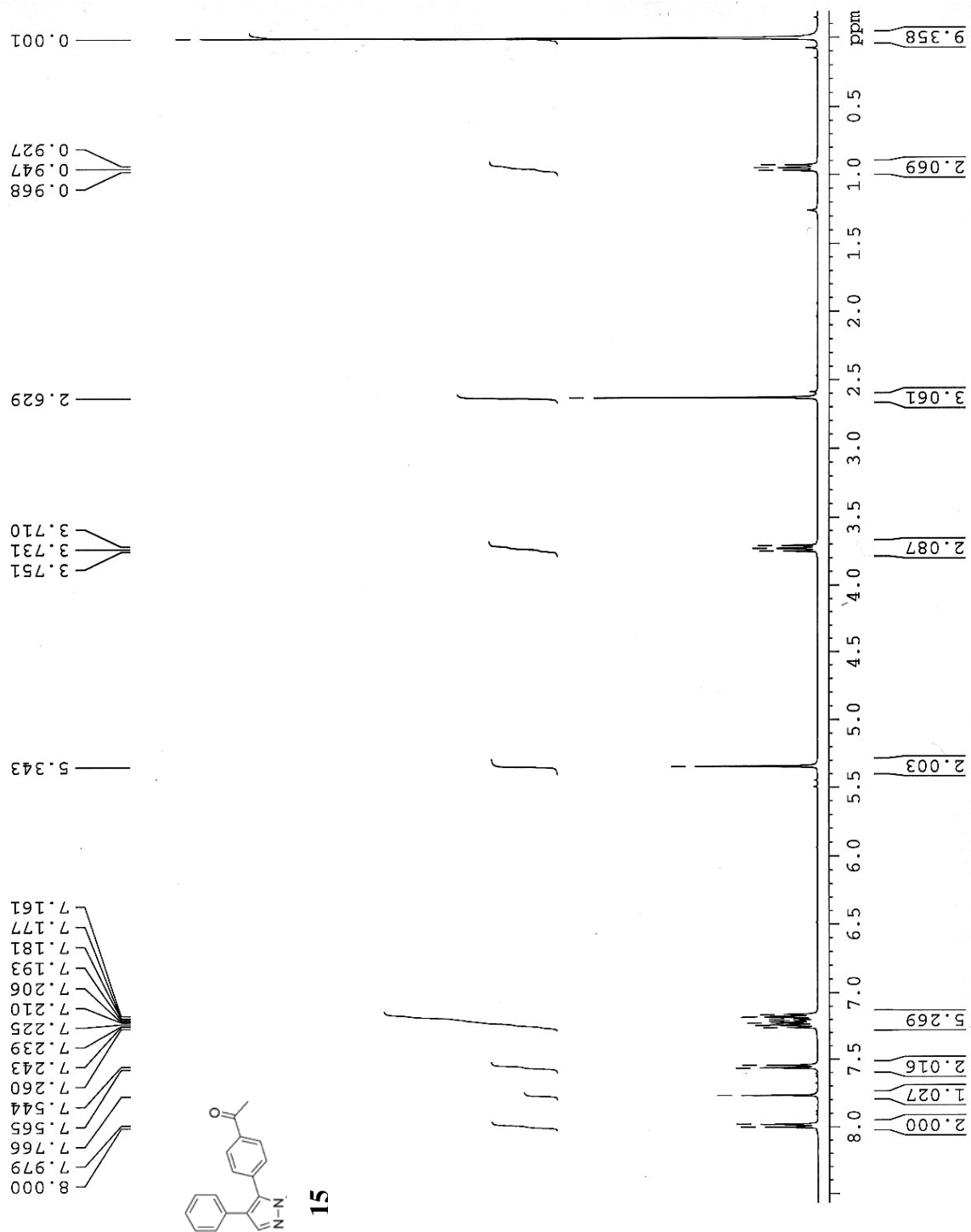

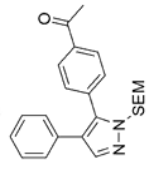
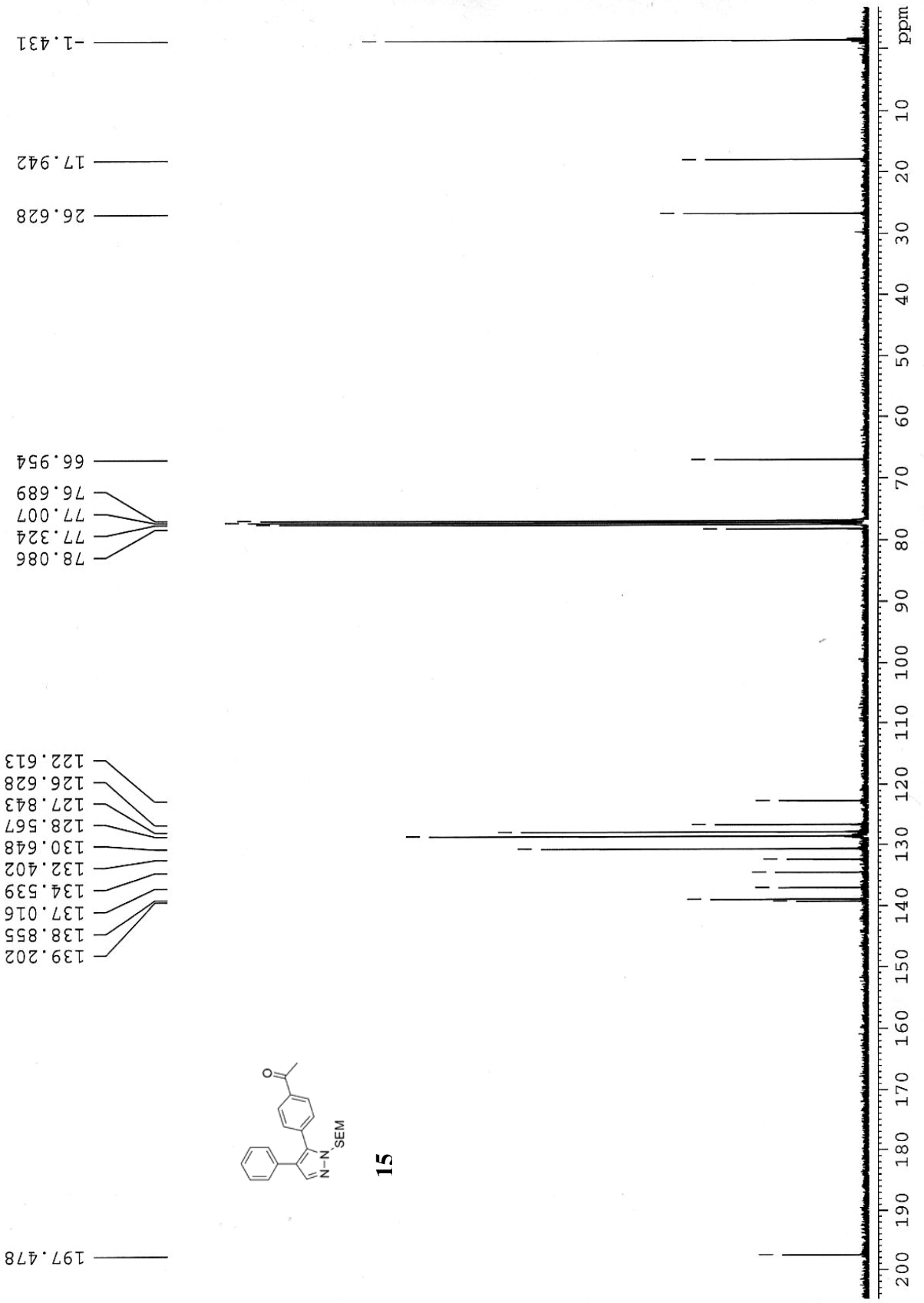

15

TLJ-2-051p 1H 400MHz CDCl3

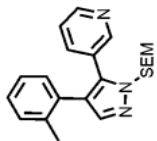

16

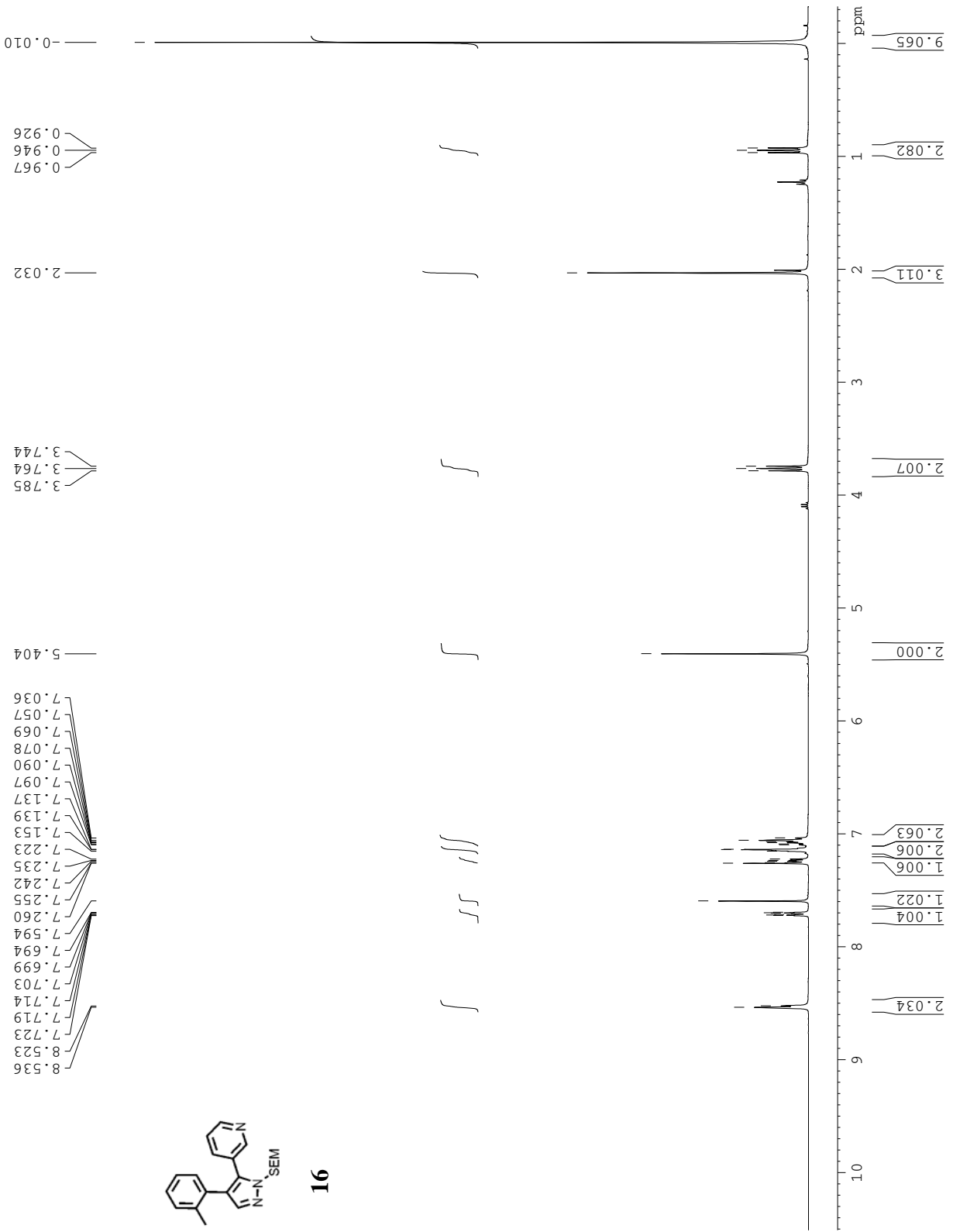

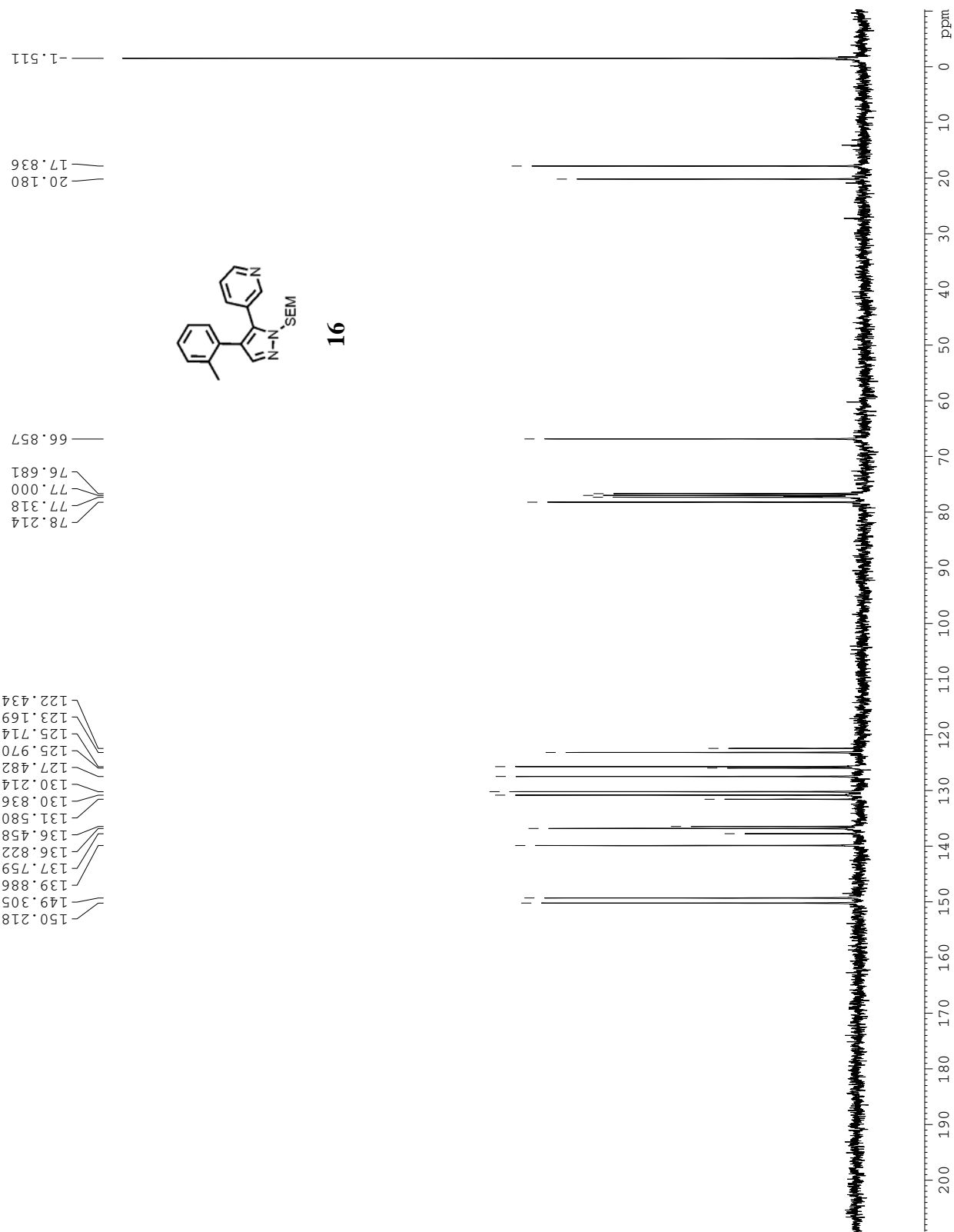

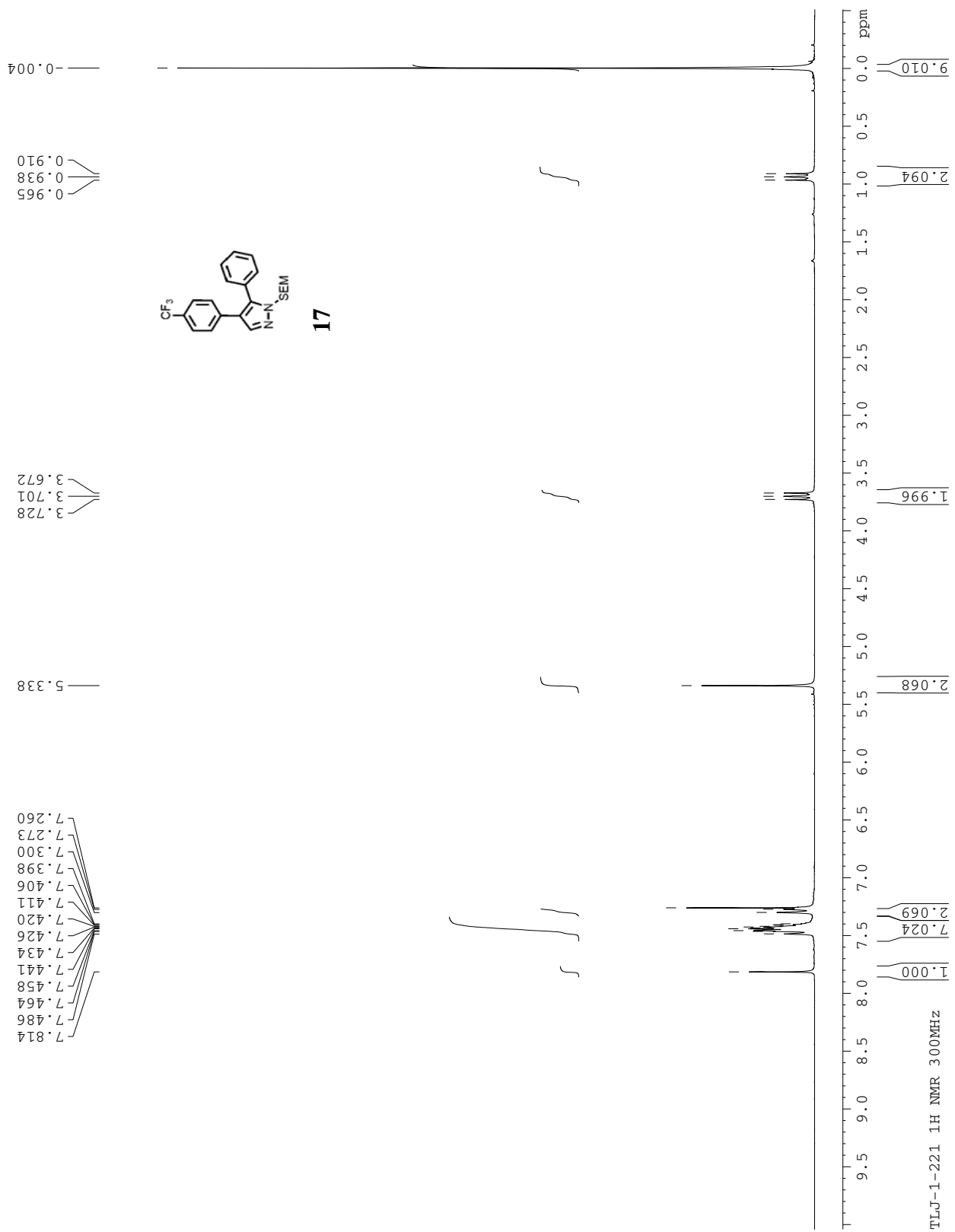



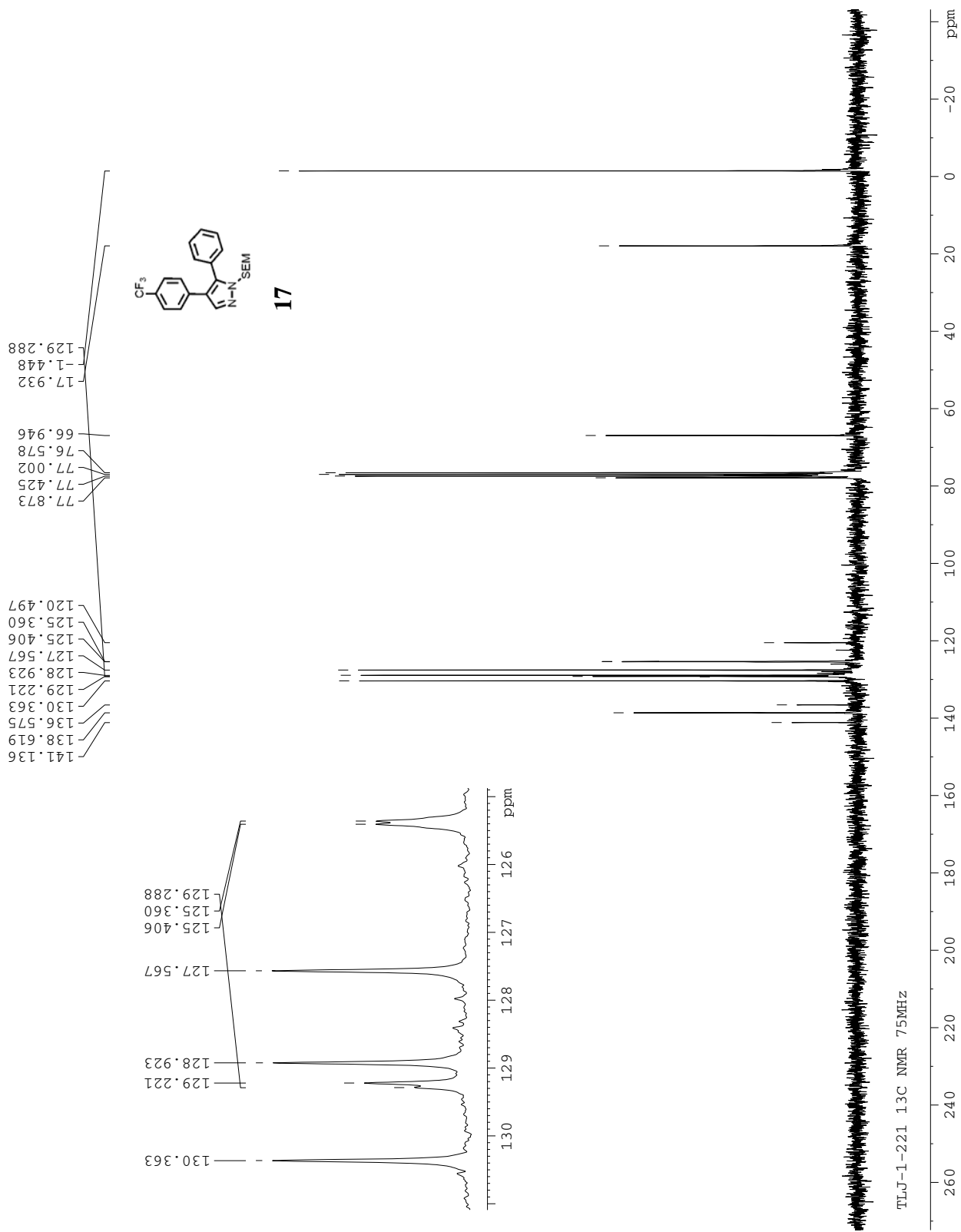

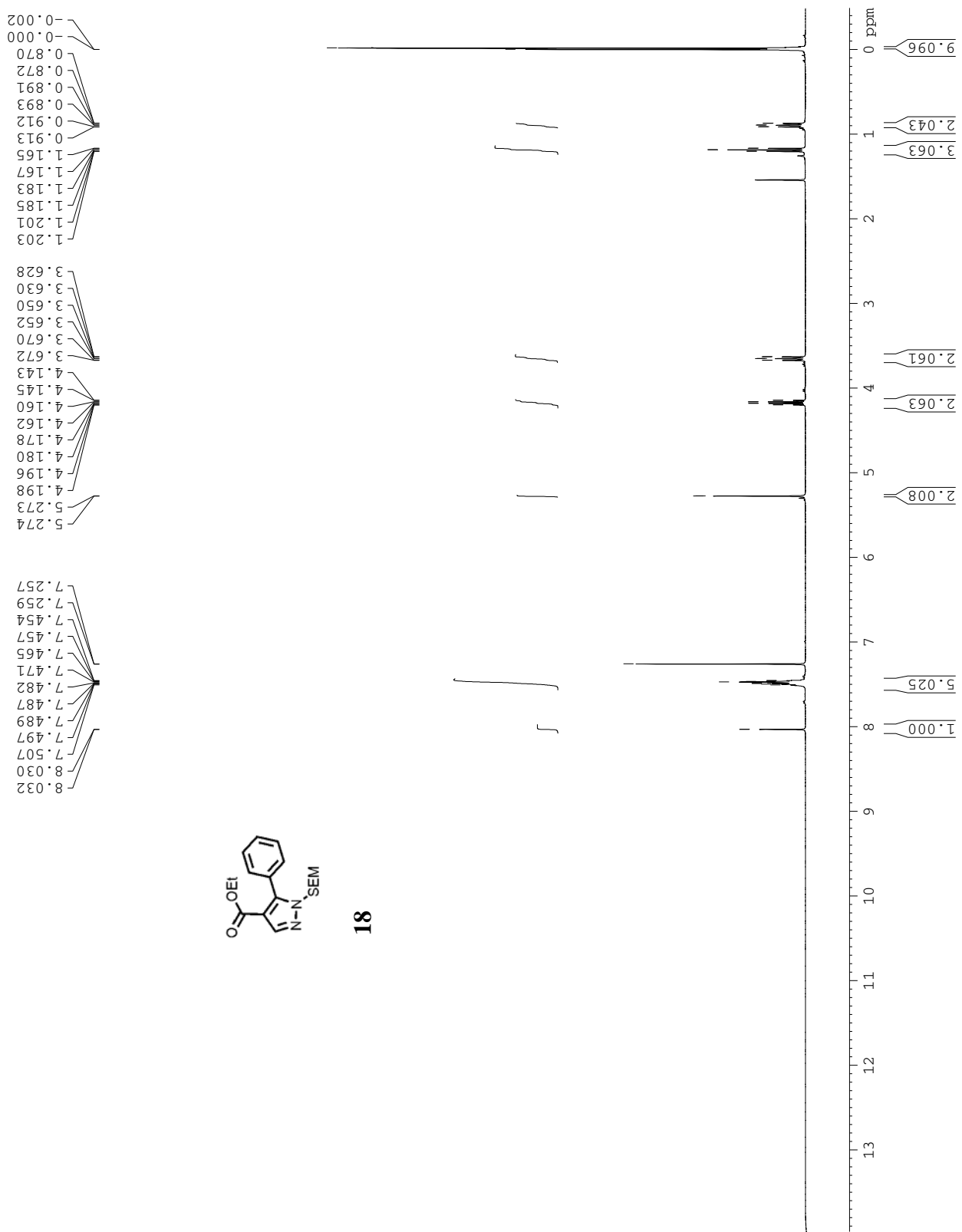

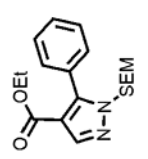
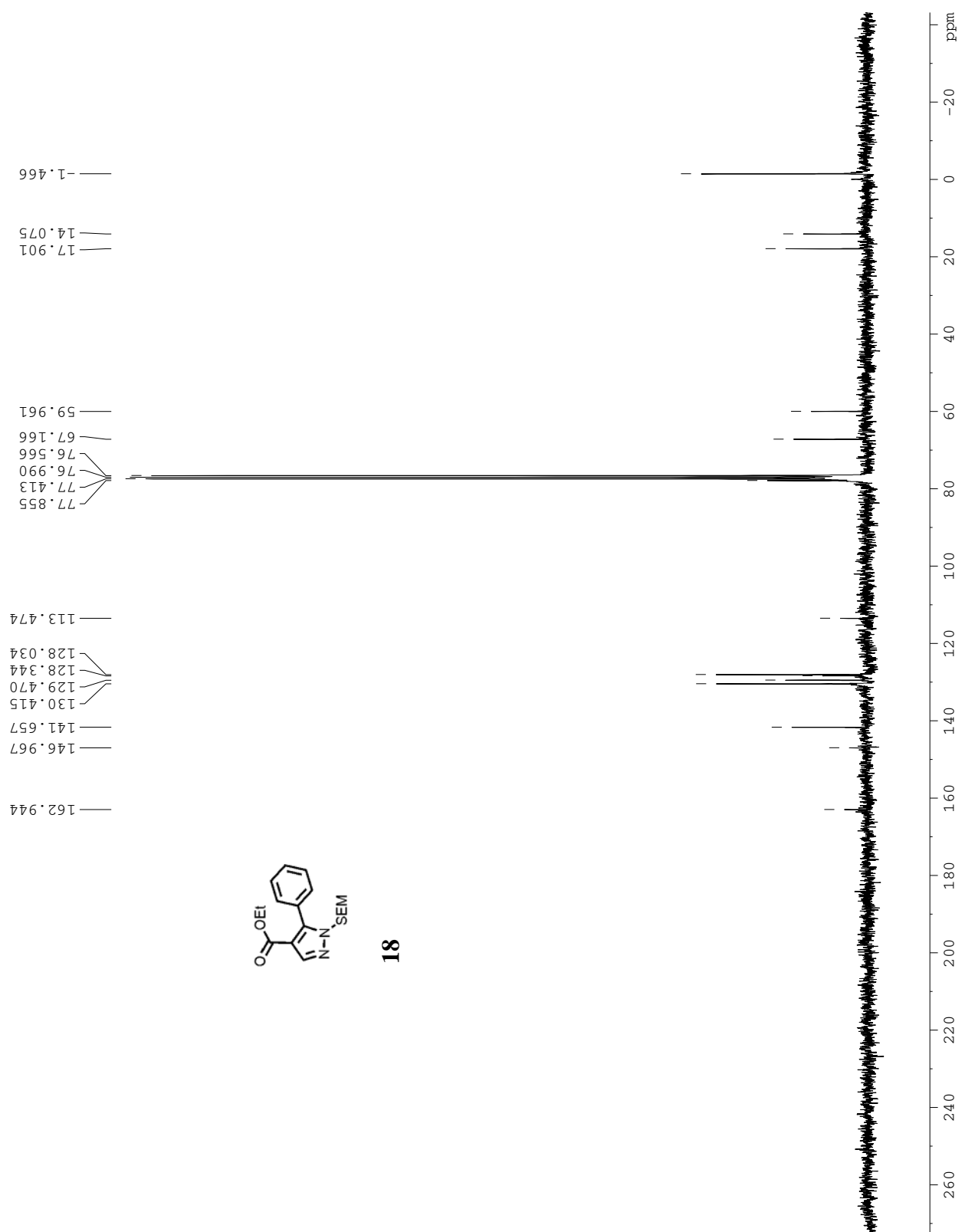

18

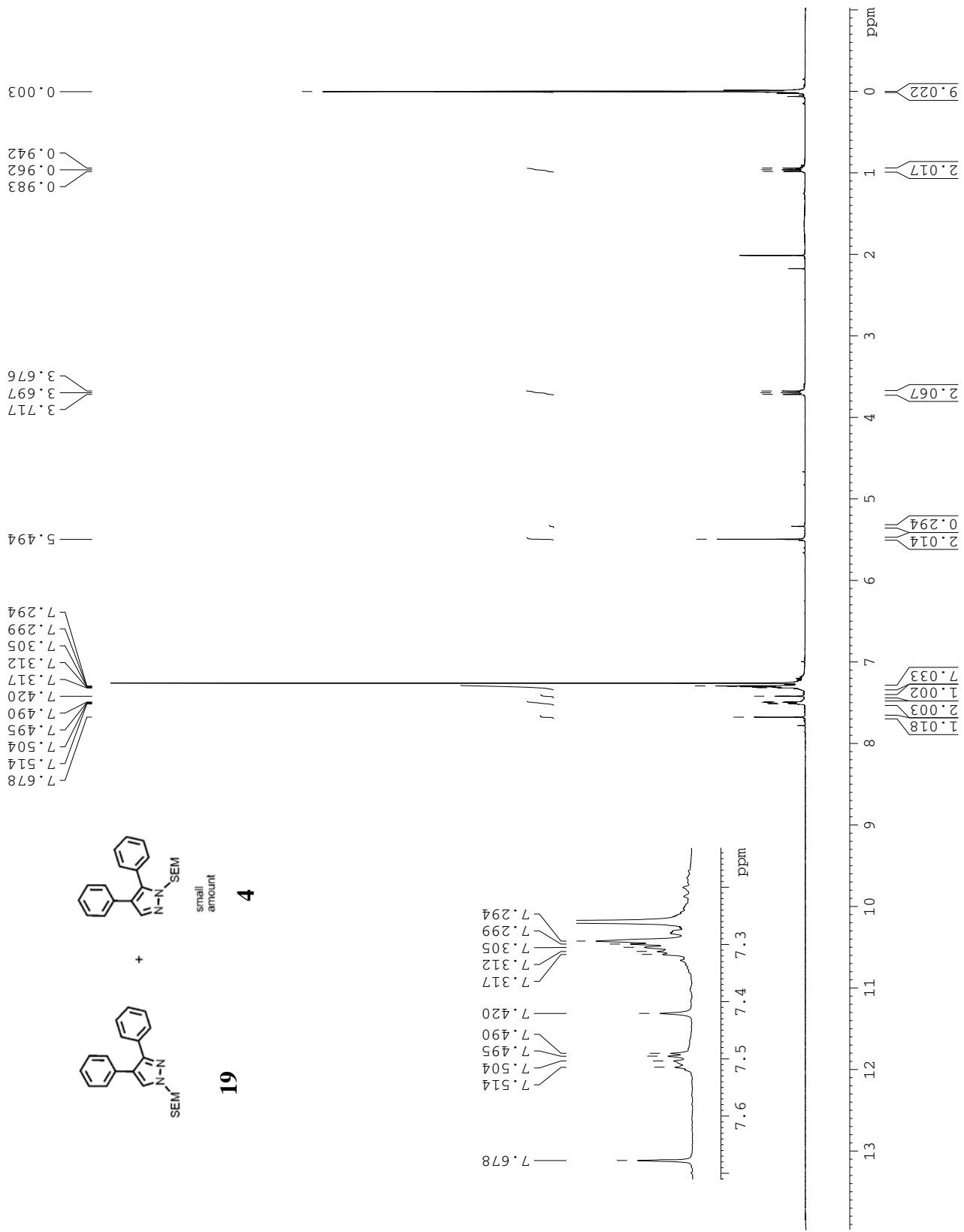

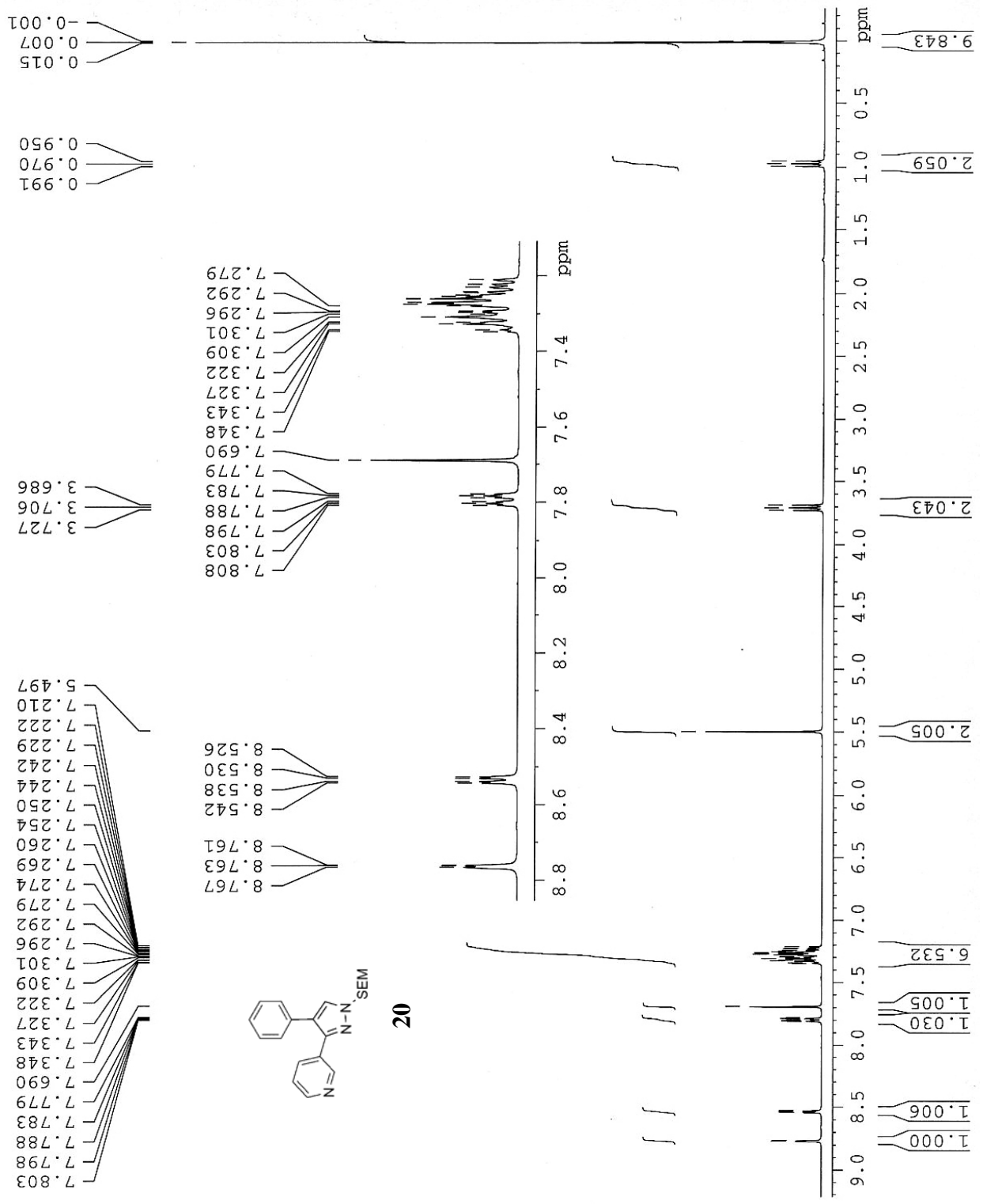

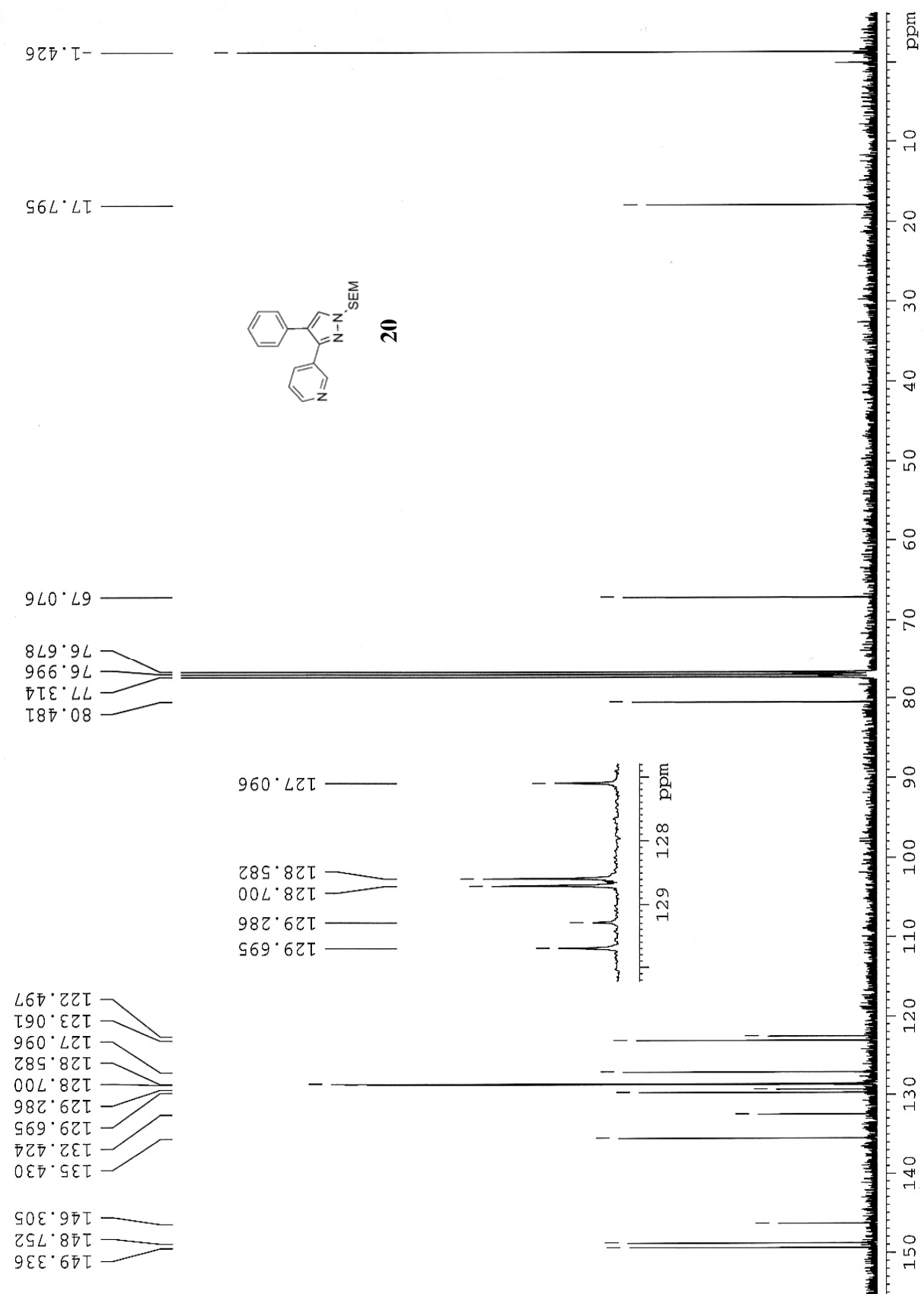

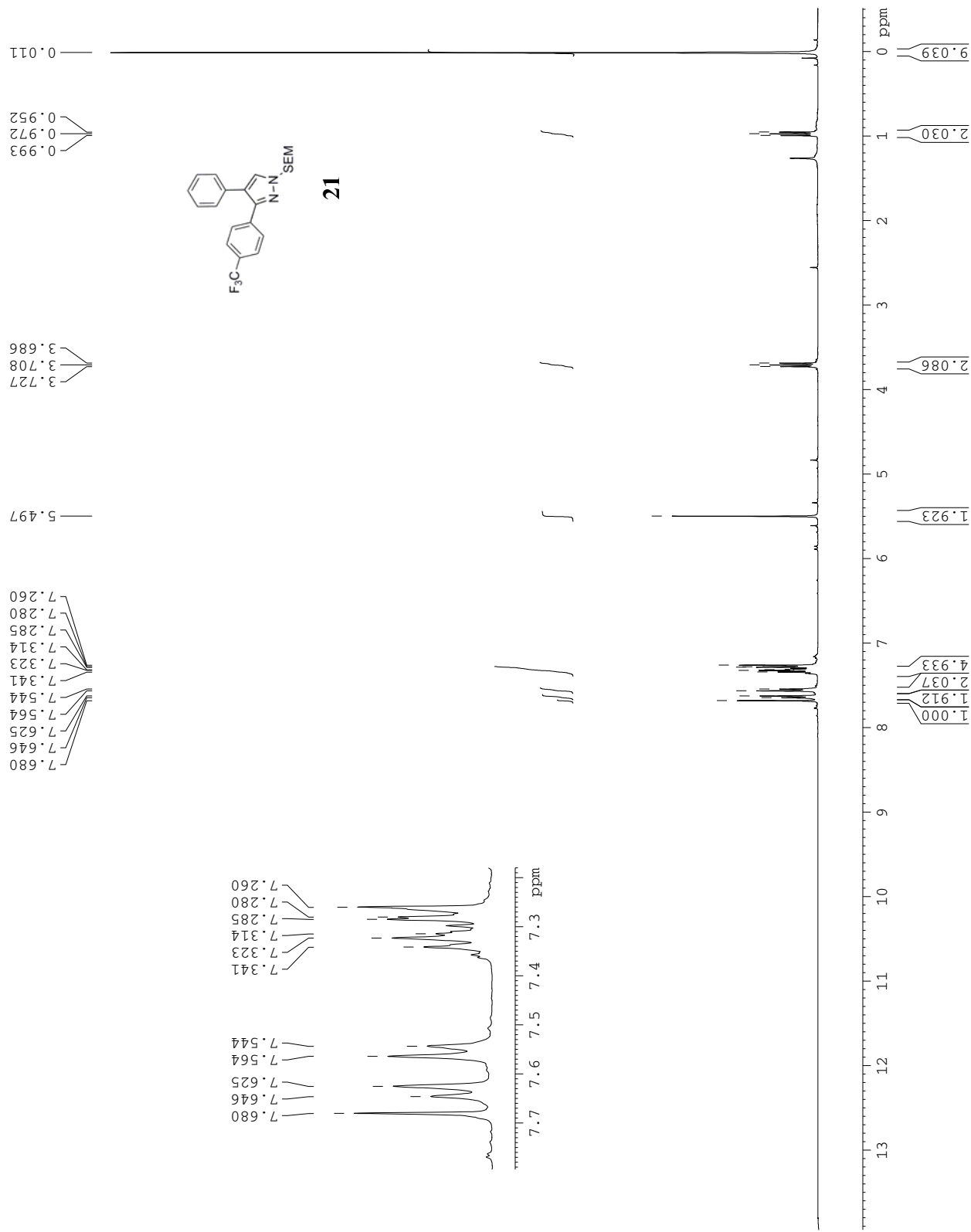

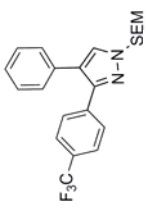

**21**

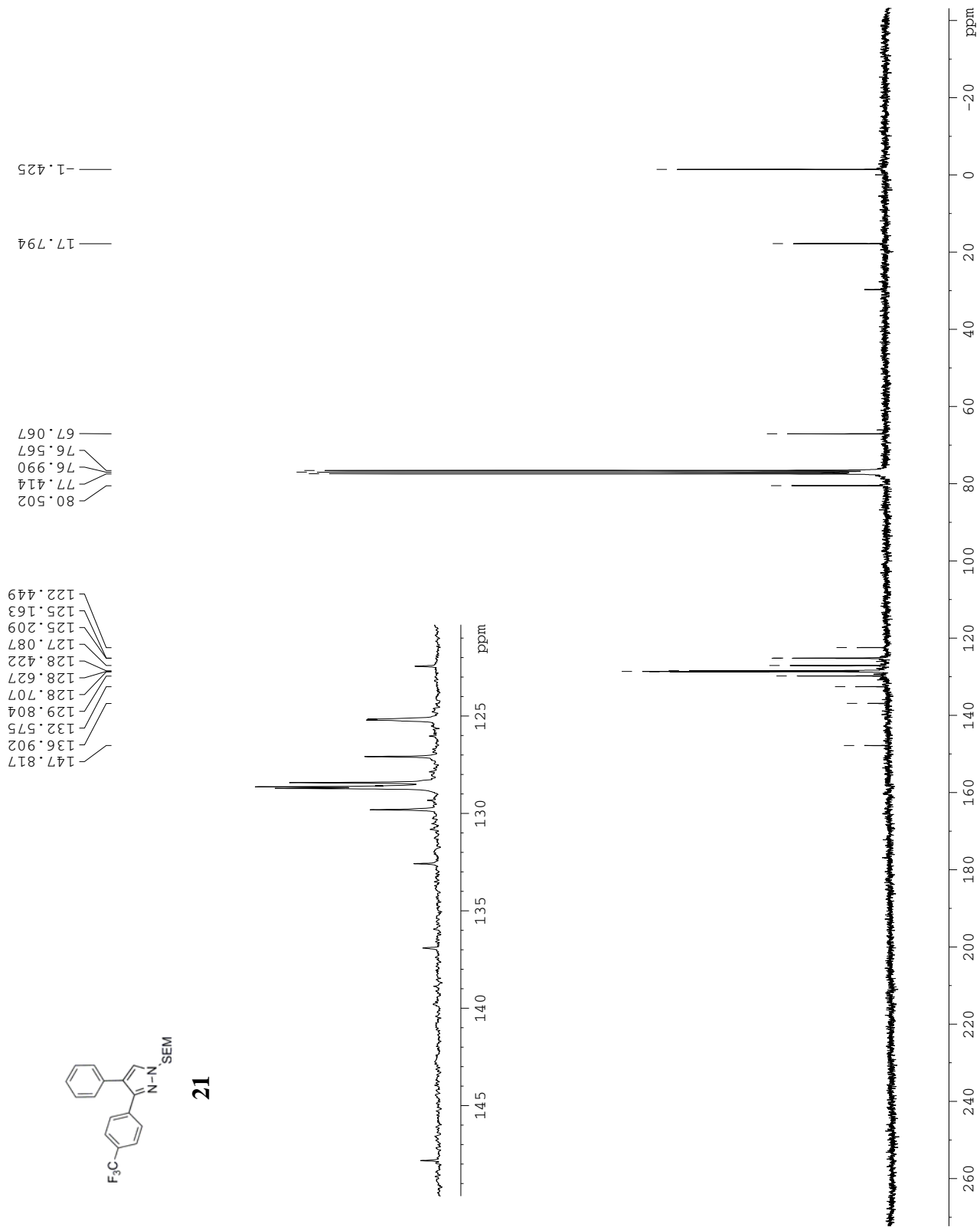



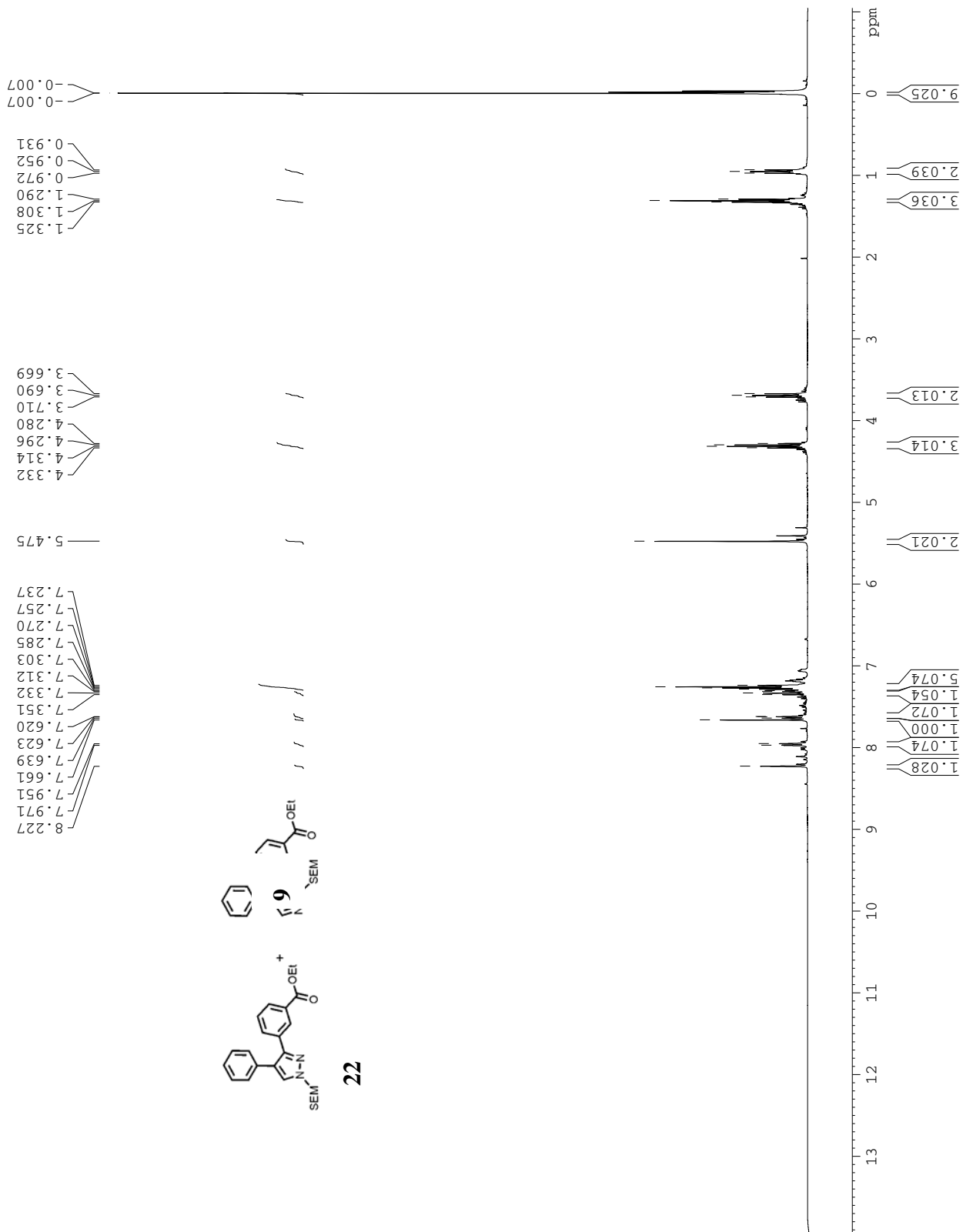

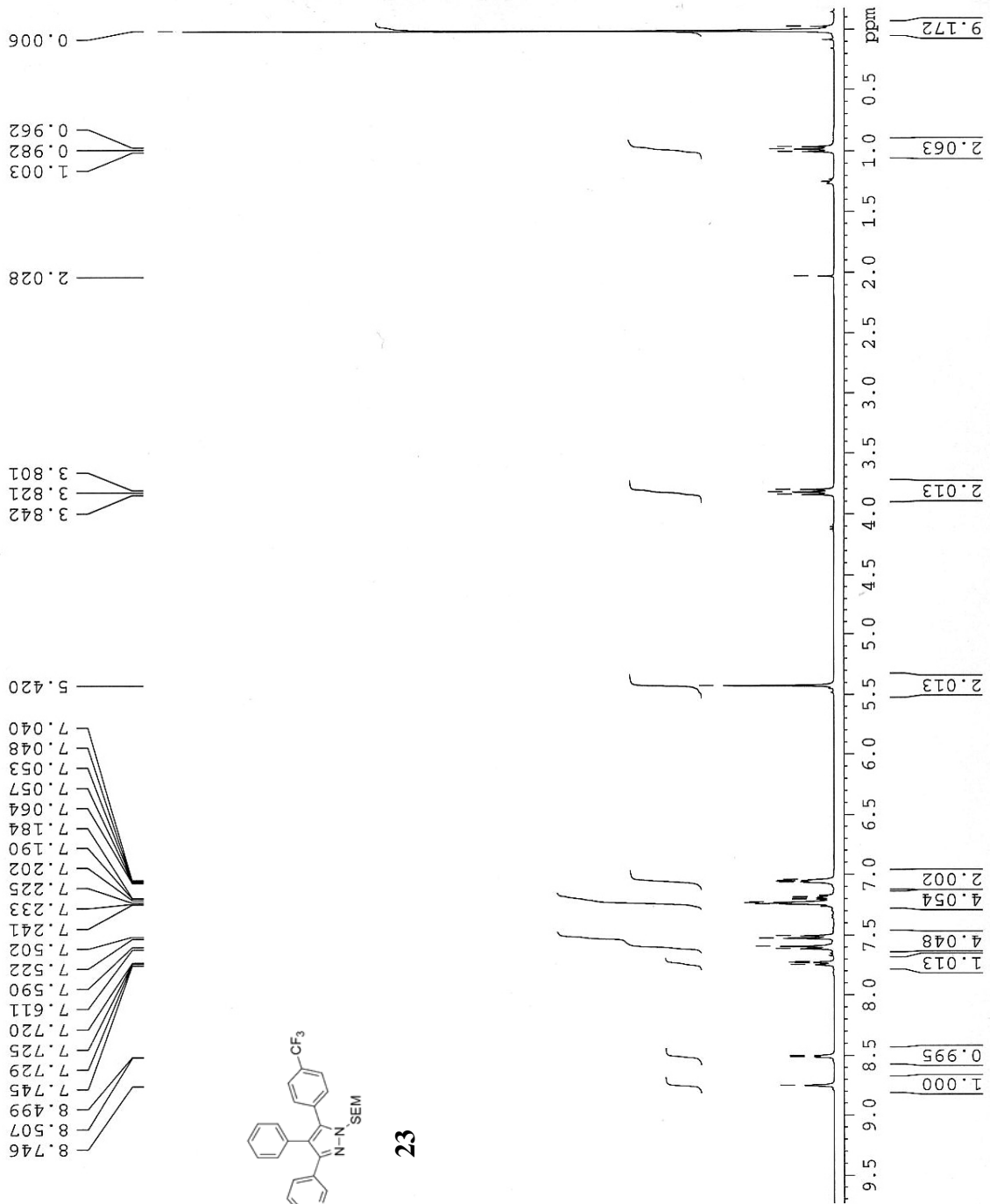

23

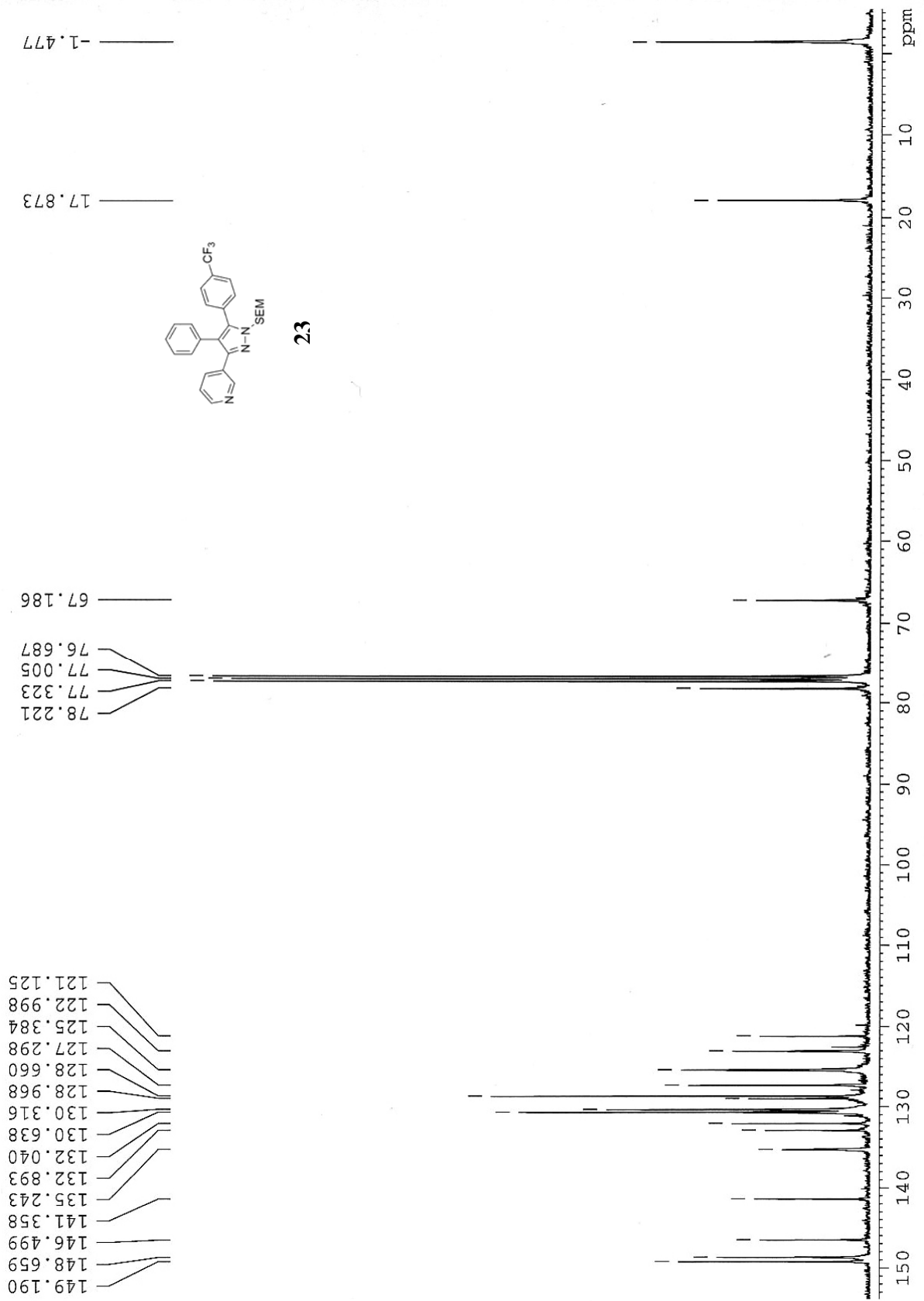

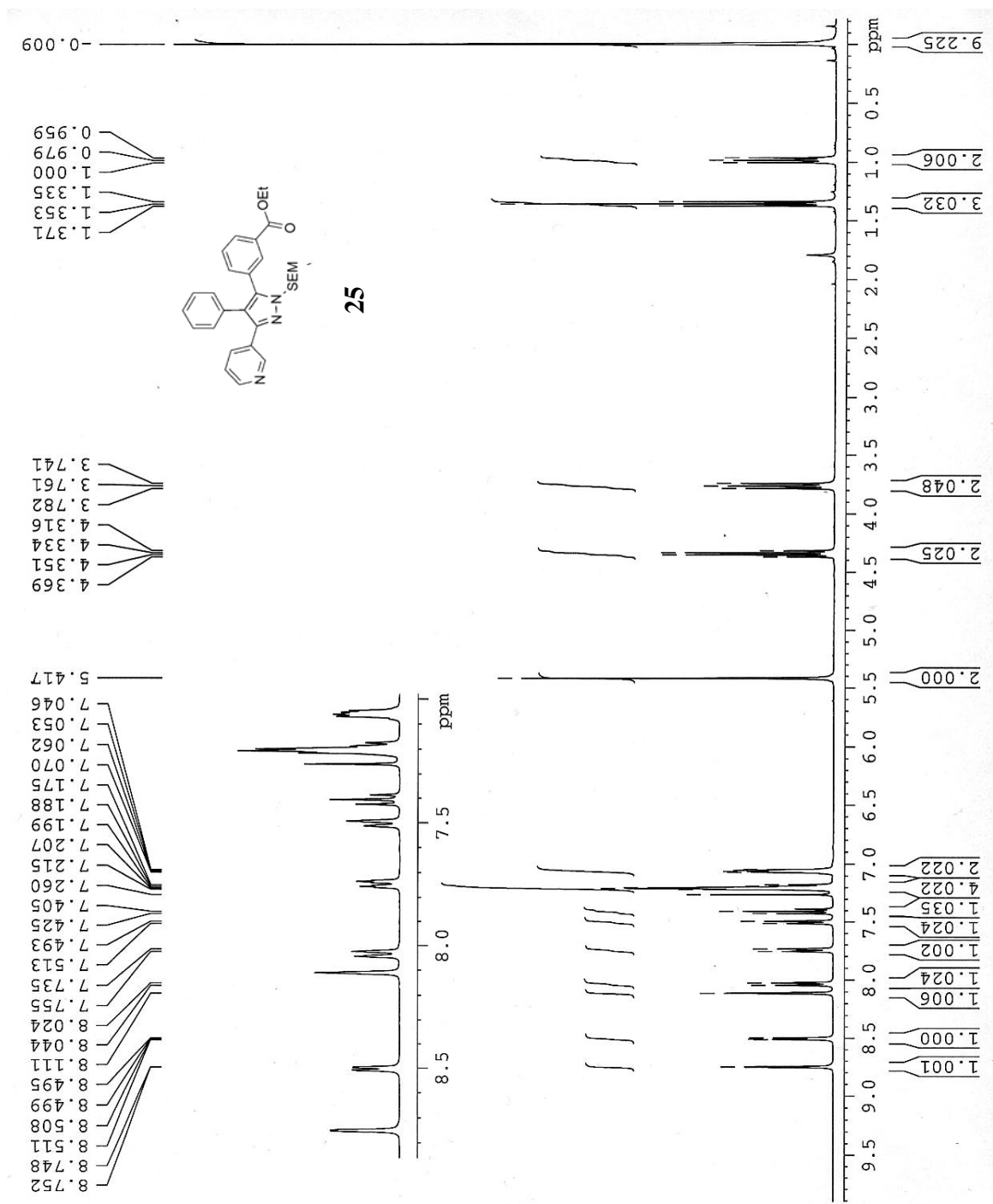

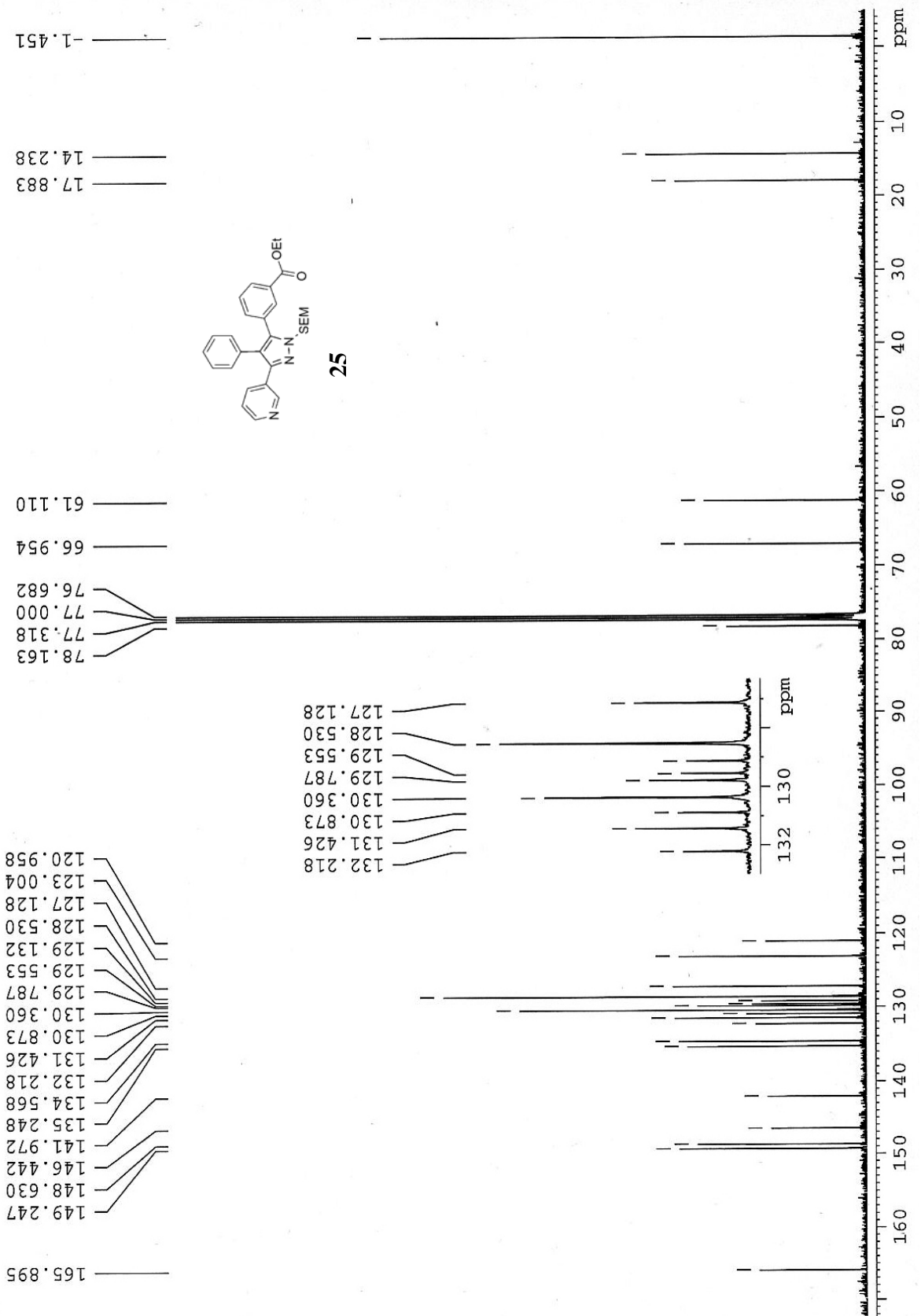

TLJ-1-206 1H 300MHz CDCl<sub>3</sub>

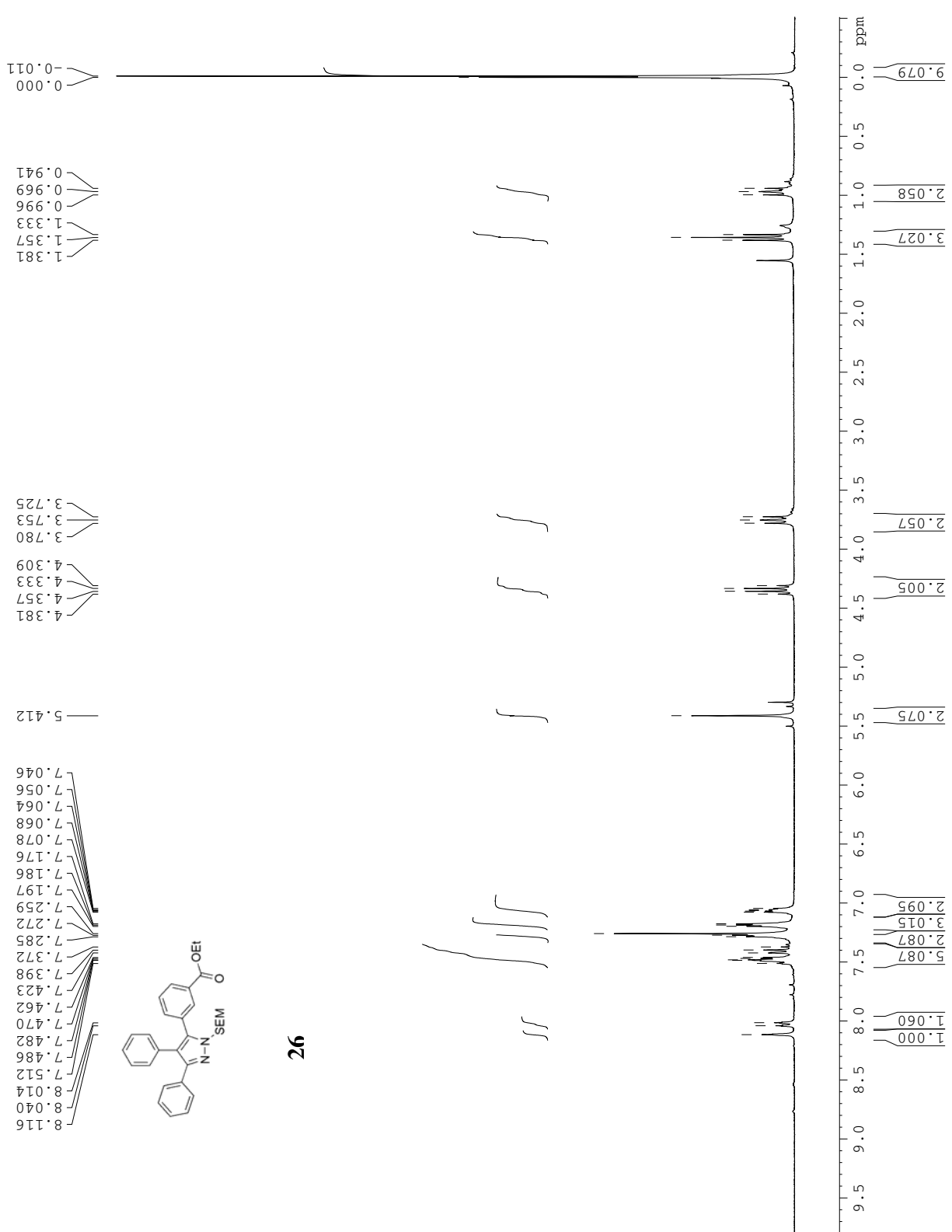

26

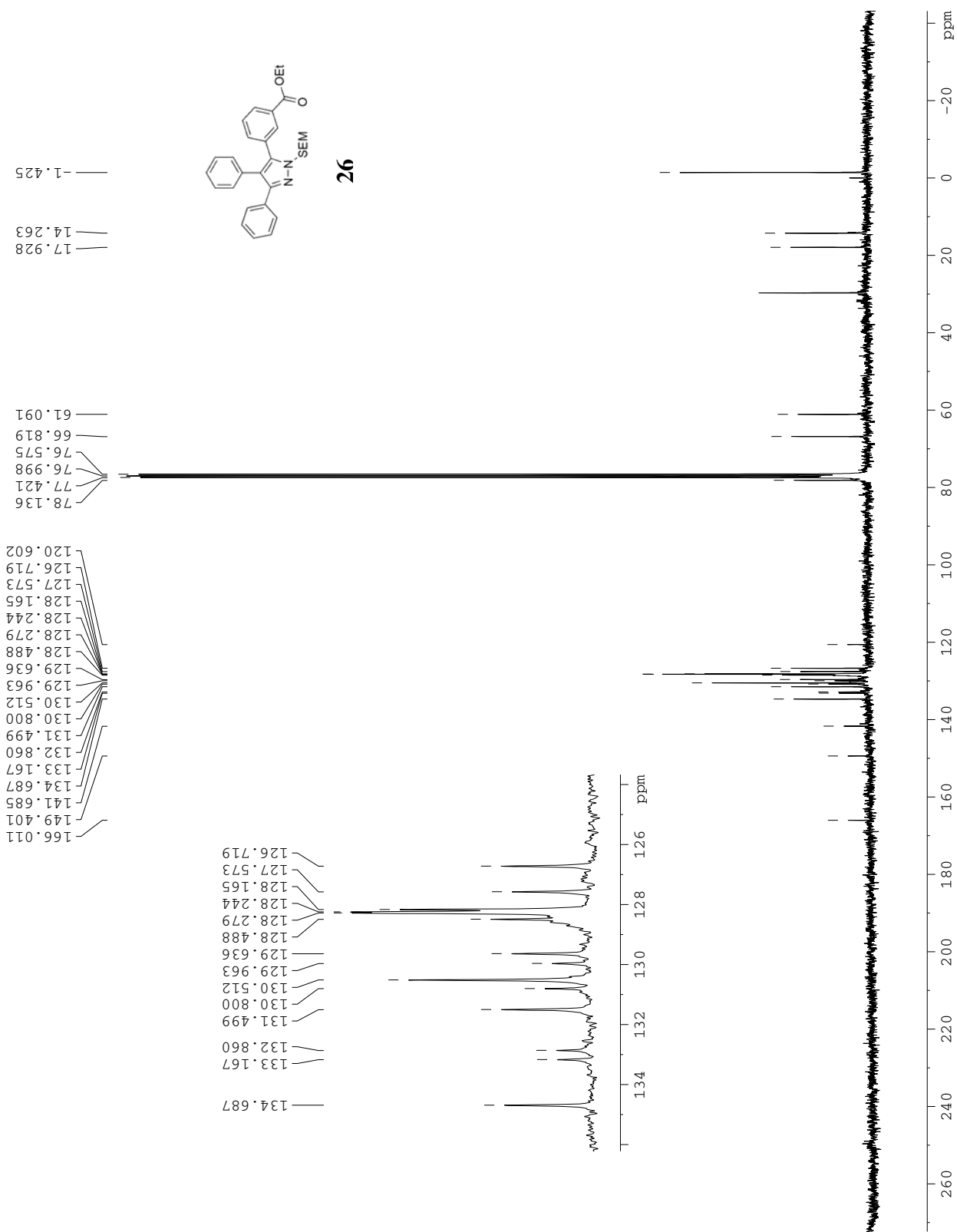

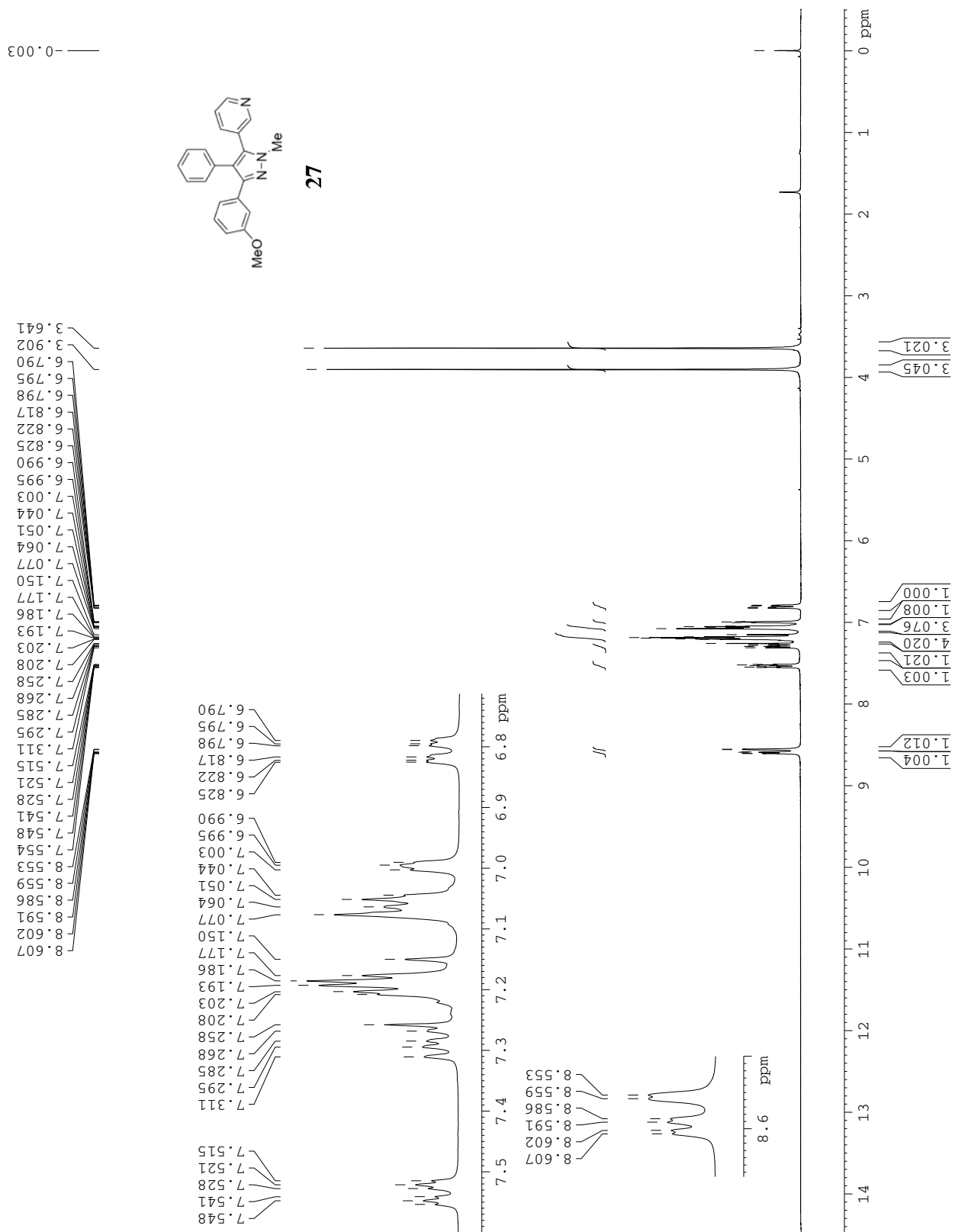





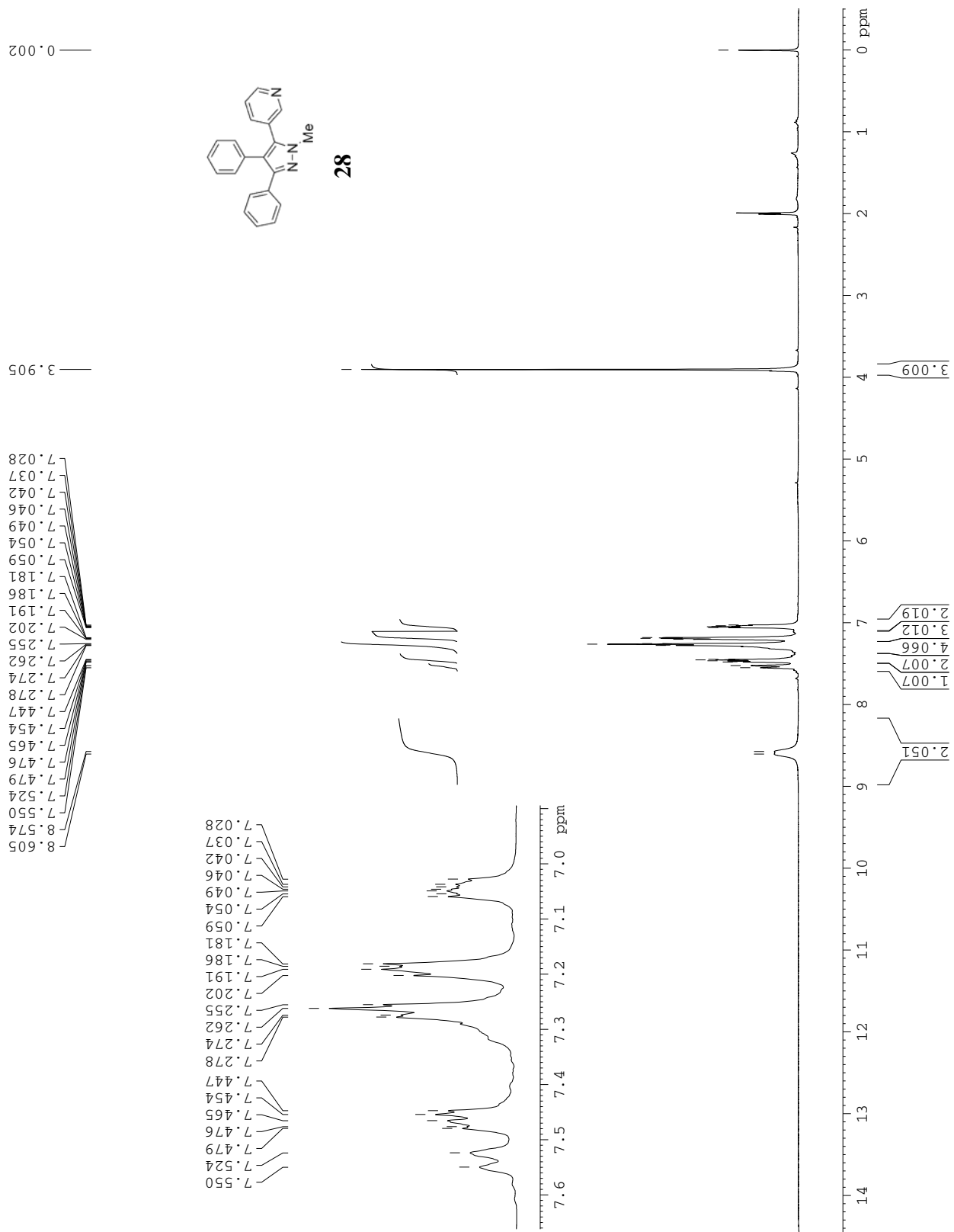

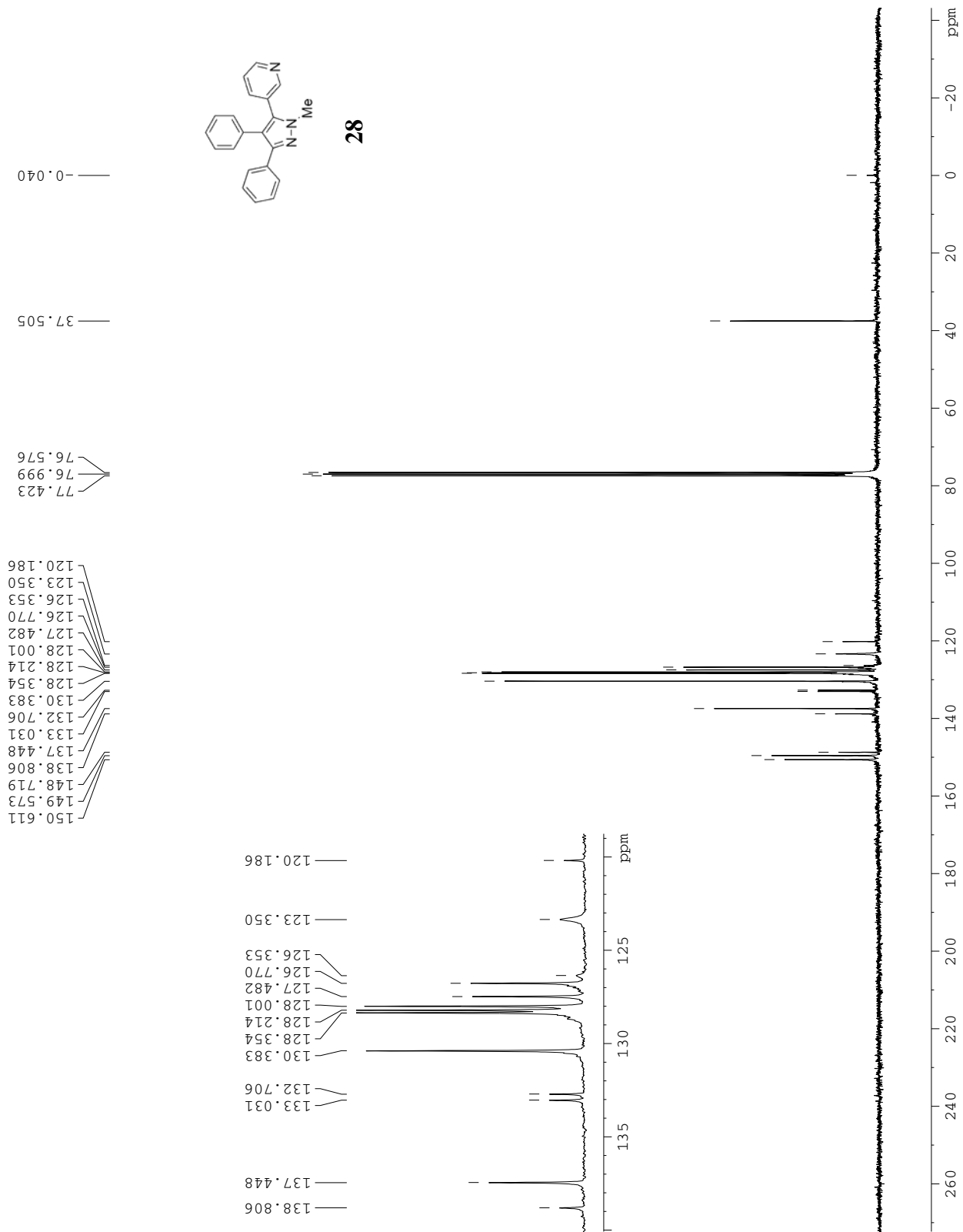

TLJ-1-218 1H 300MHz CDC13

1.337  
1.313  
1.289

3.915  
4.265  
4.289  
4.303  
4.313  
4.326  
4.336  
7.022  
7.032  
7.036  
7.040  
7.044  
7.054  
7.193  
7.203  
7.214  
7.243  
7.255  
7.273  
7.290  
7.303  
7.315  
7.340  
7.471  
7.520  
7.526  
7.532  
7.546  
7.552  
7.582  
7.586  
7.591  
7.613  
7.919  
7.923  
7.945  
7.949  
8.183  
8.188  
8.559  
8.598  
8.607

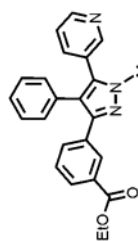

29

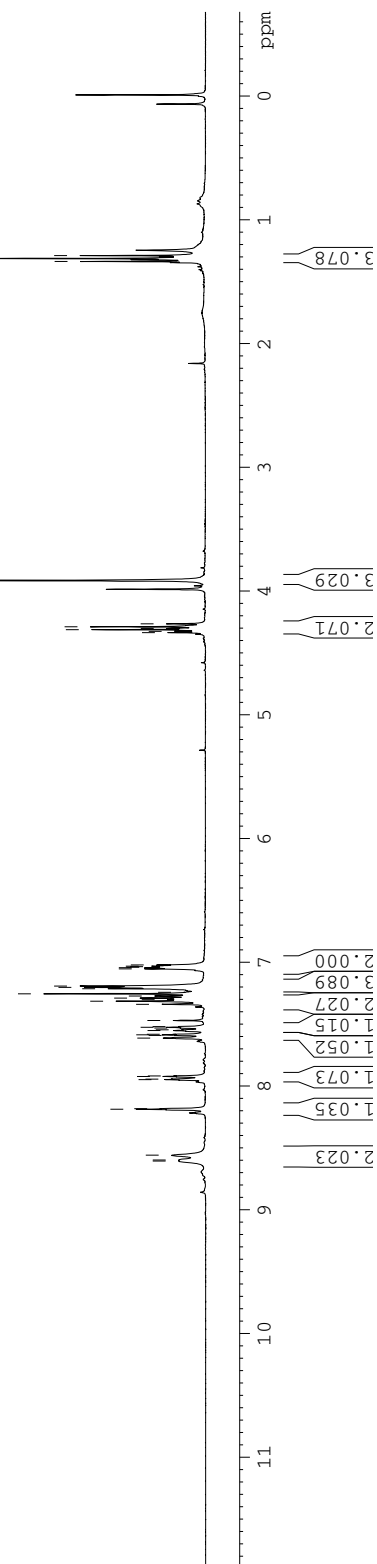
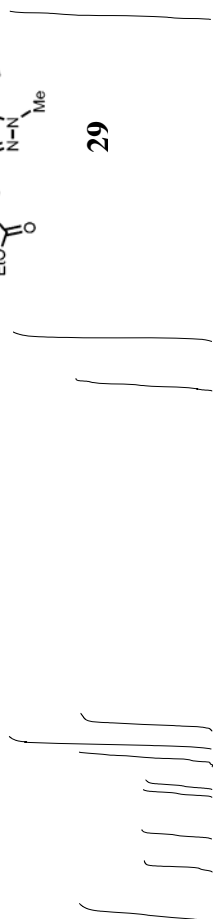

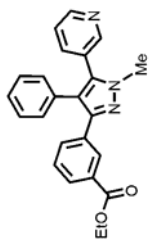

29

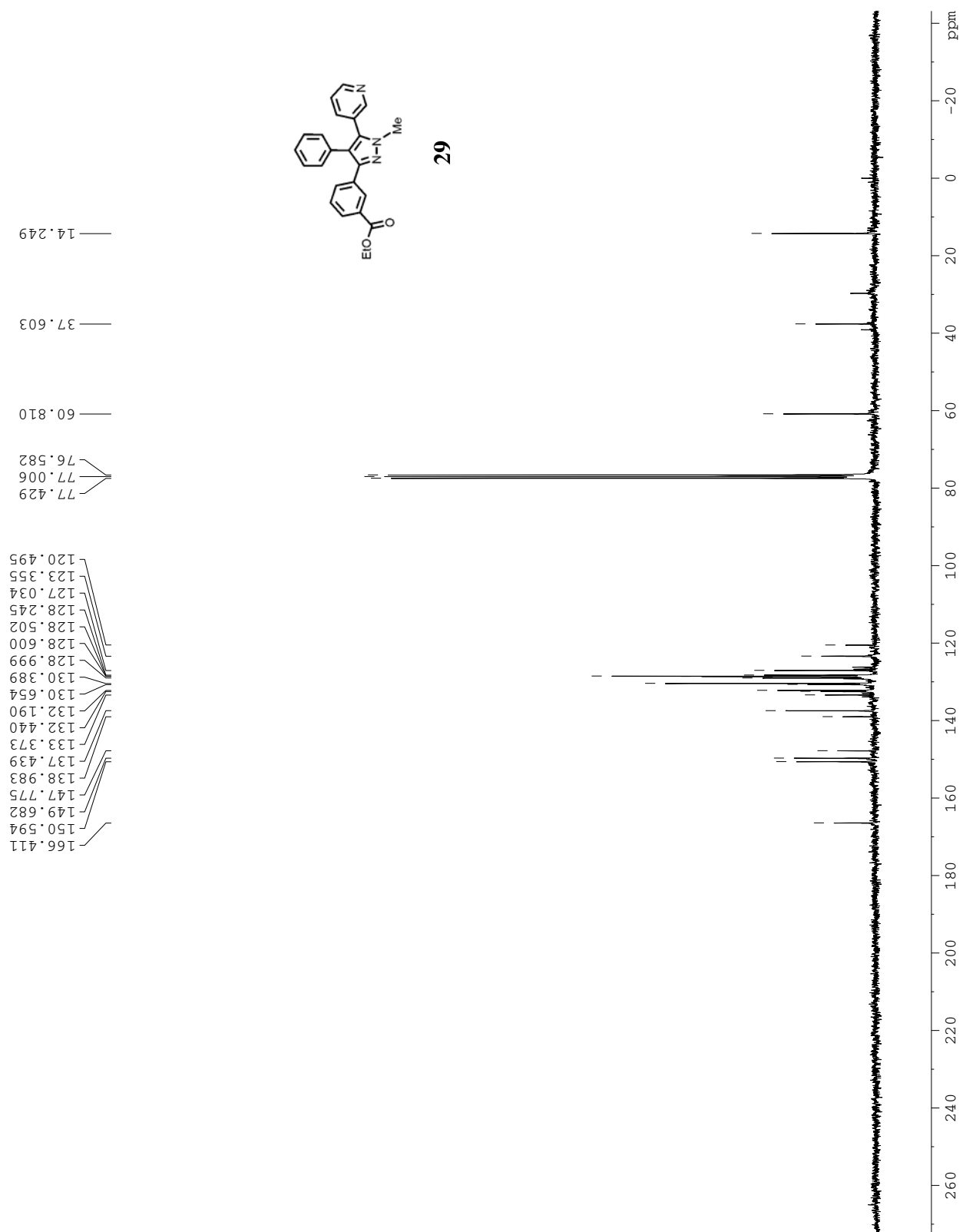

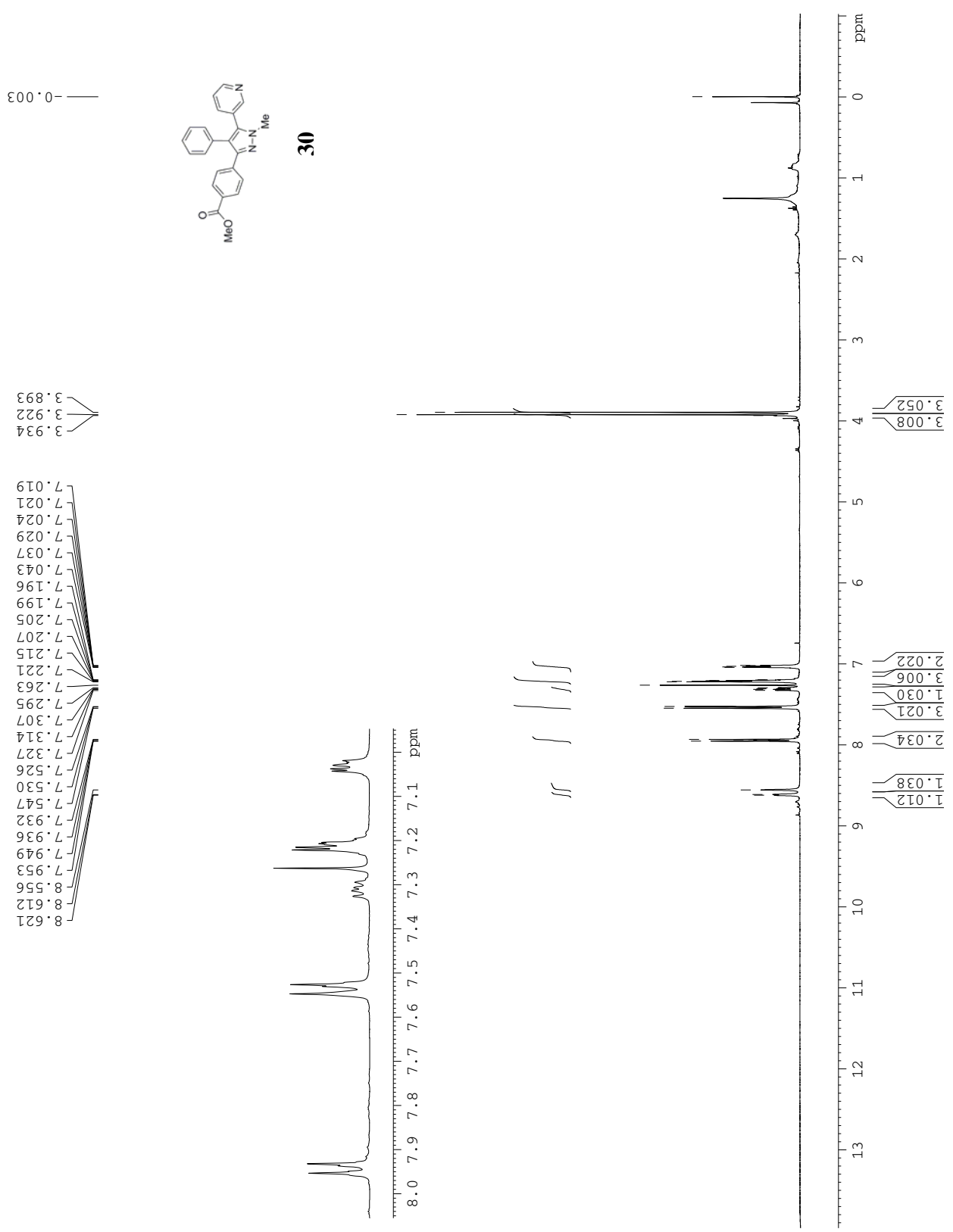

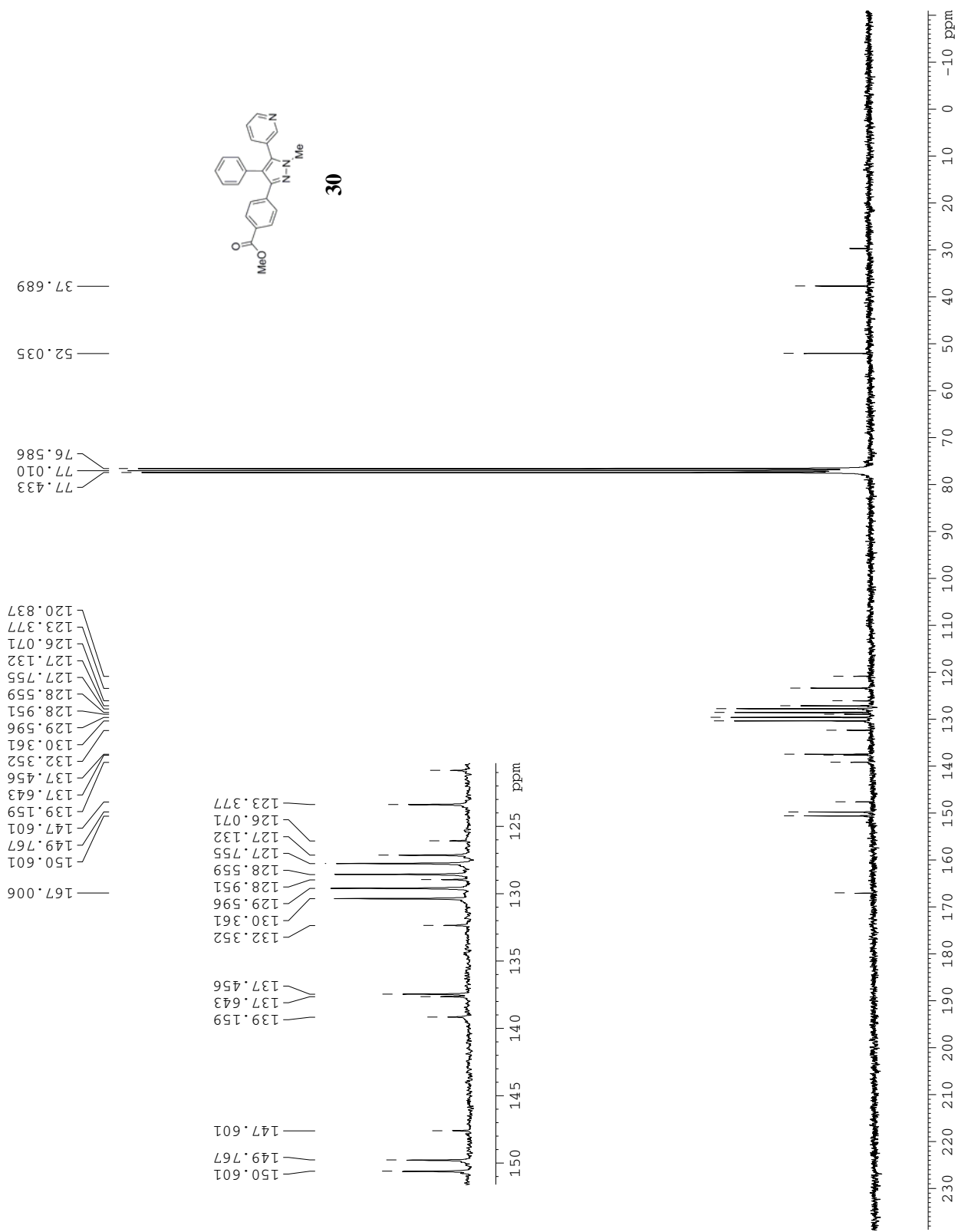

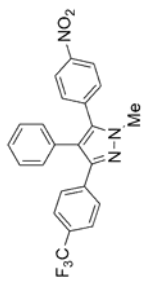

31

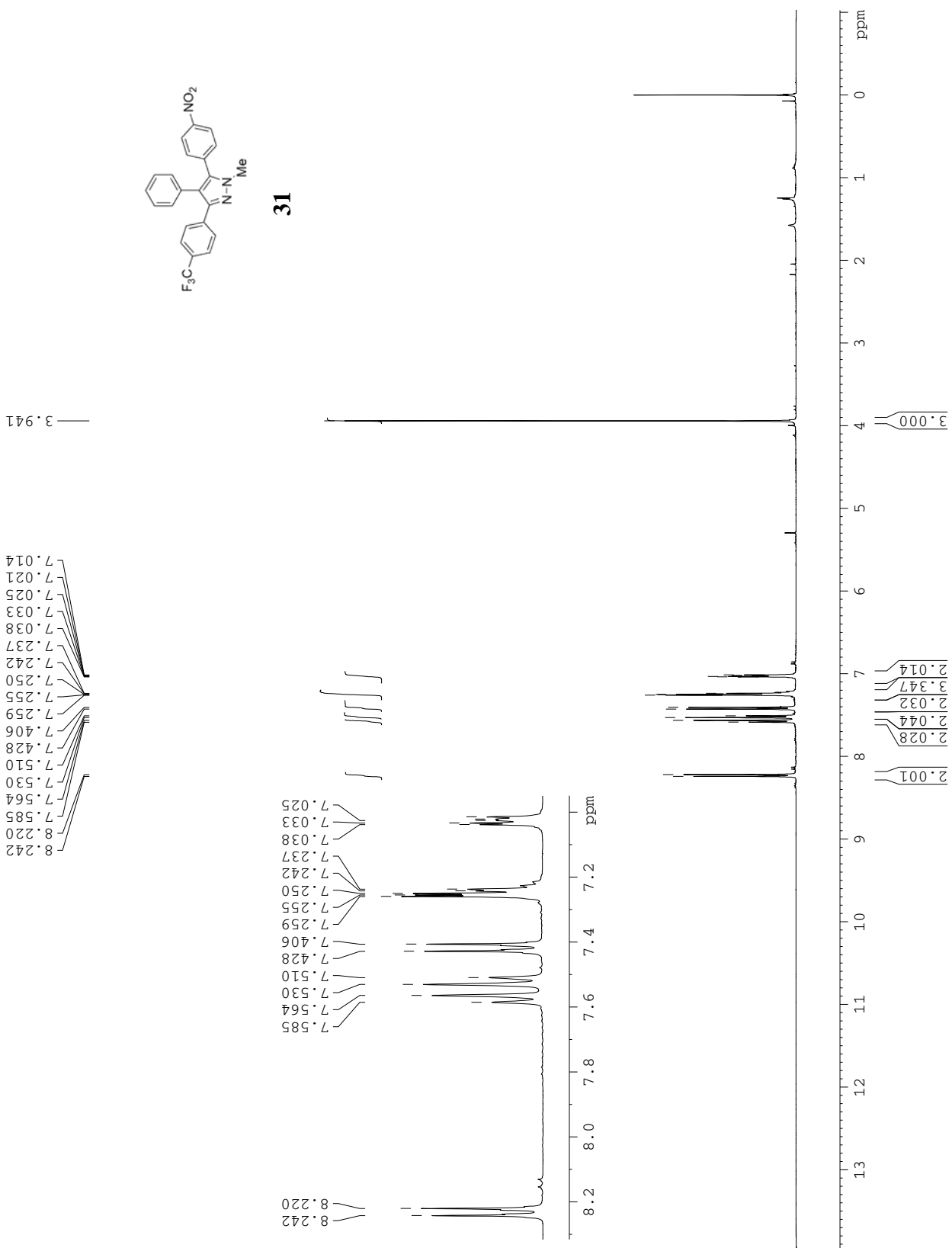



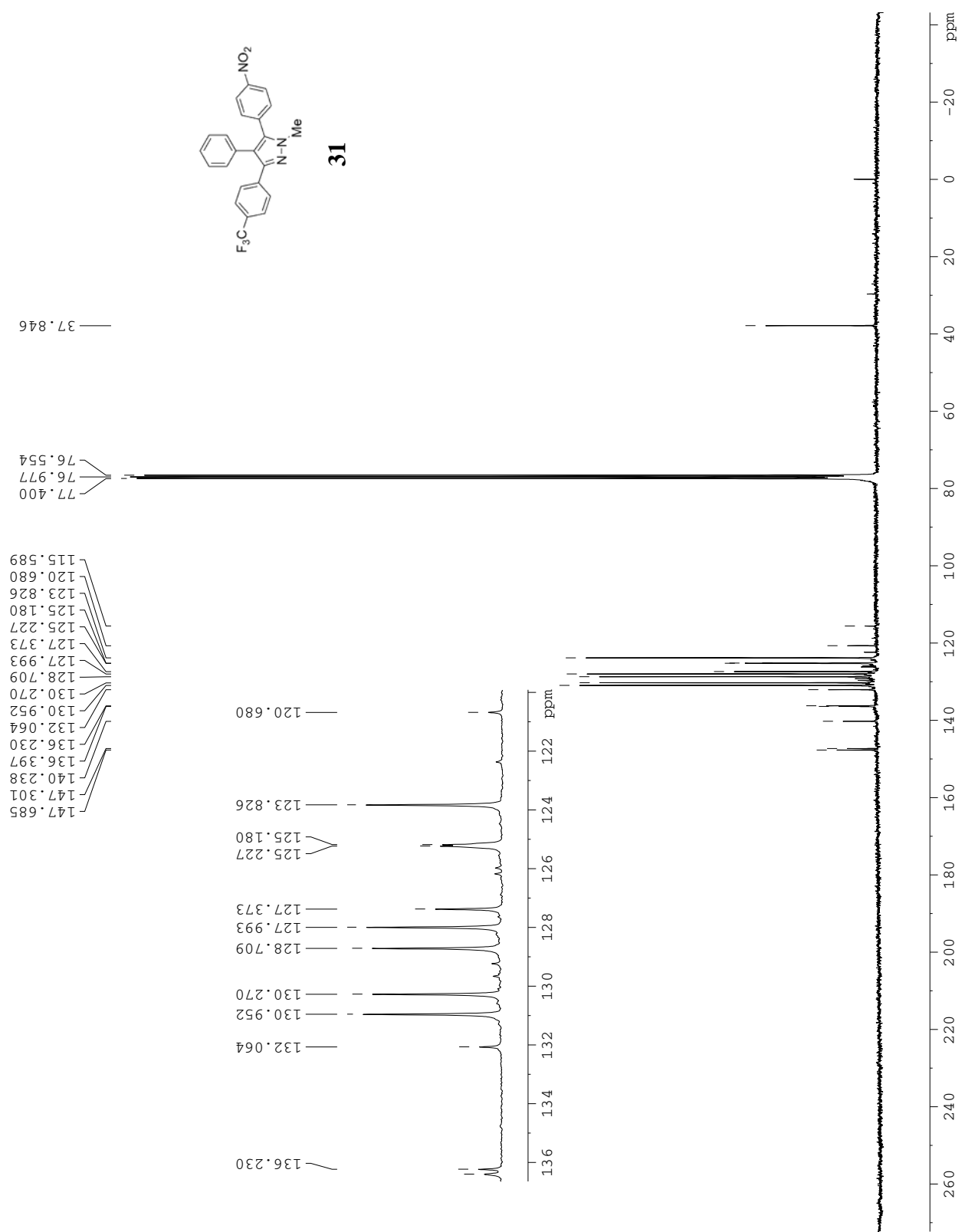

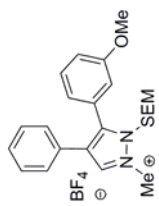
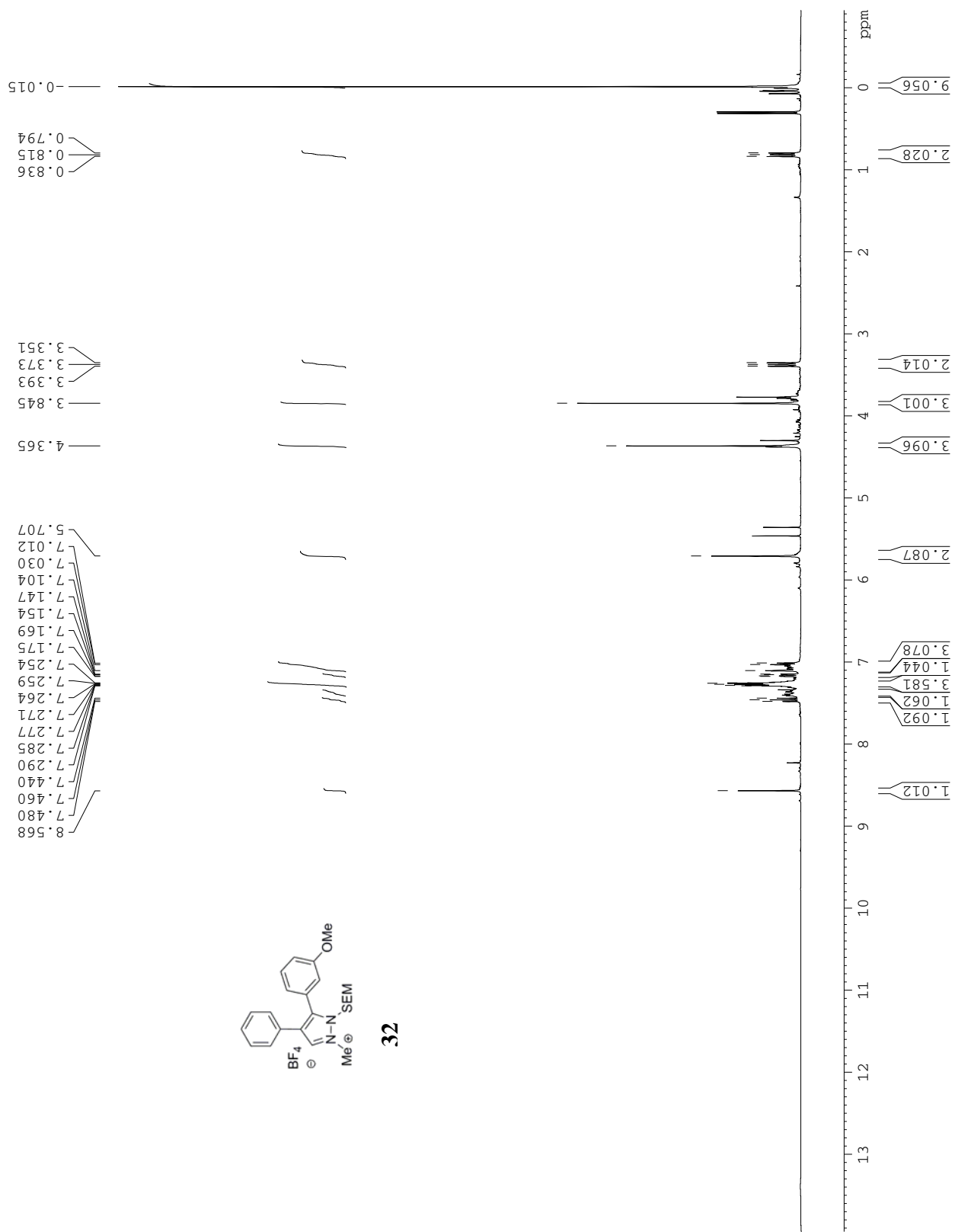

32

—0.001

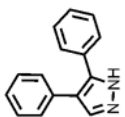

SI

7.631  
7.479  
7.473  
7.468  
7.463  
7.458  
7.455  
7.335  
7.328  
7.319  
7.303  
7.264  
7.254  
7.252  
7.244

—11.518

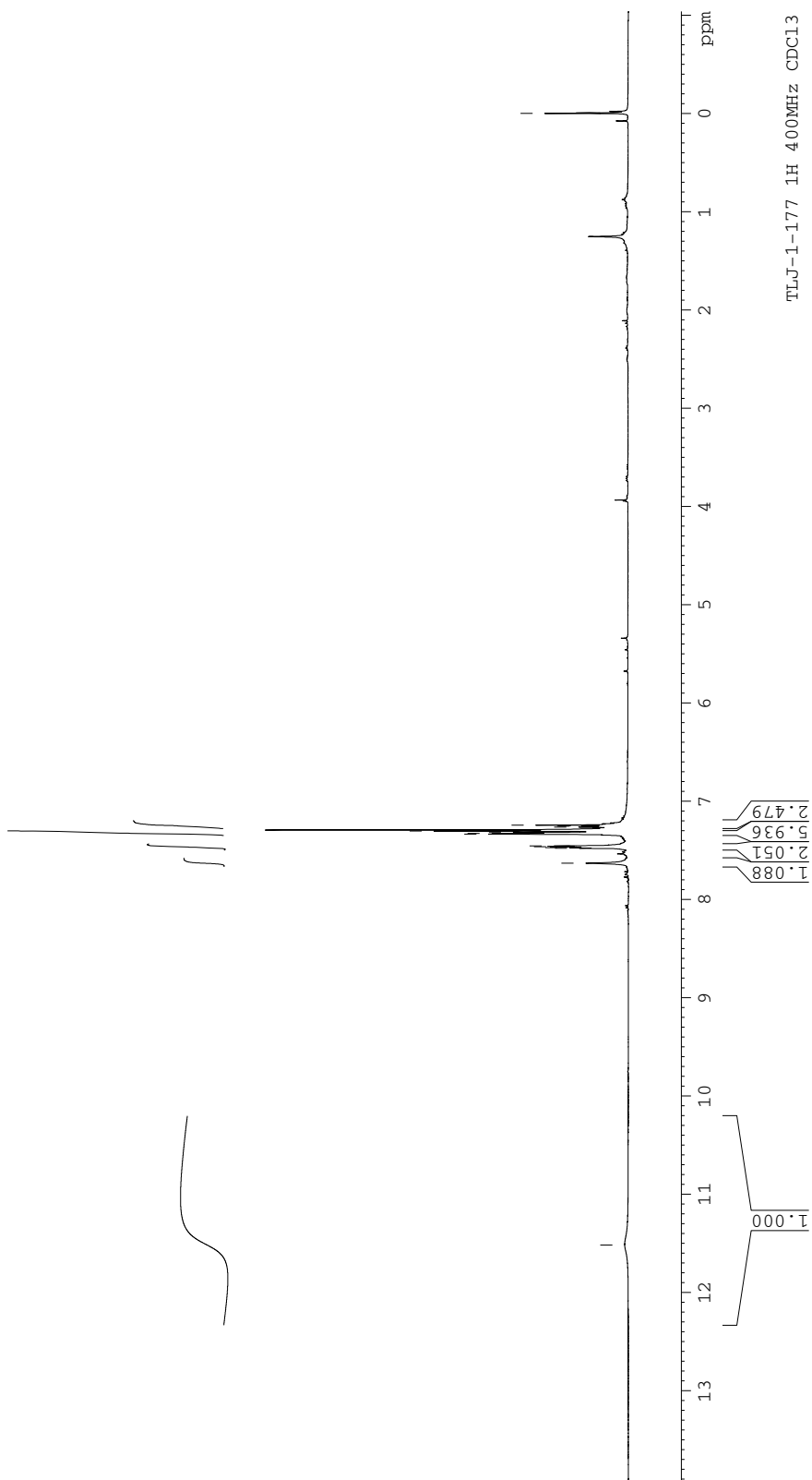

TLJ-1-177 1H 400MHz DMSO

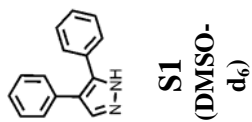

2.502  
2.498

8.314  
8.311  
7.399  
7.327  
7.306  
7.288  
7.268  
7.247  
7.244  
7.225

13.193  
13.051

13.193  
13.051

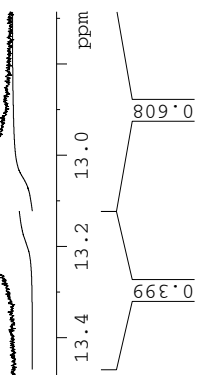

3.161  
6.952

0.399  
0.608



TLJ-2-084 13C 75MHz CDCl3

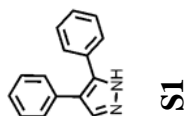

77.416  
76.993  
76.569

135.052  
133.103  
131.316  
128.600  
128.482  
128.406  
128.178  
127.981  
127.921  
126.559

135.052  
133.103  
131.316  
128.600  
128.482  
128.406  
128.178  
127.981  
127.921  
126.559

135  
130  
125  
ppm

190  
180  
170  
160  
150  
140  
130  
120  
110  
100  
90  
80  
70  
60  
50  
40  
30  
20  
10  
ppm

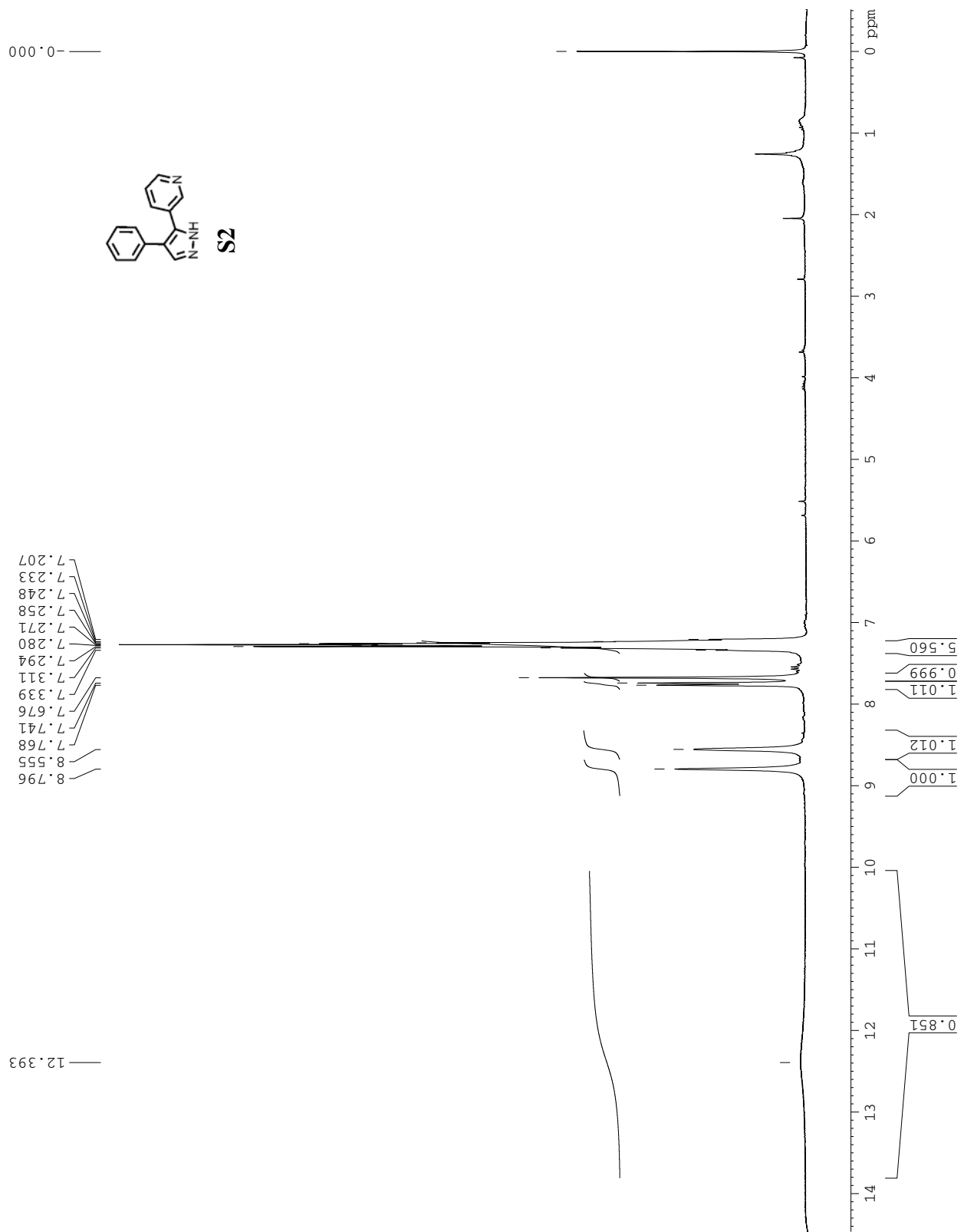

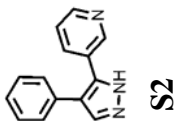

77.426  
77.003  
76.579

148.913  
148.831  
143.014  
135.594  
132.461  
128.723  
128.517  
126.999  
123.347  
120.909  
132.274

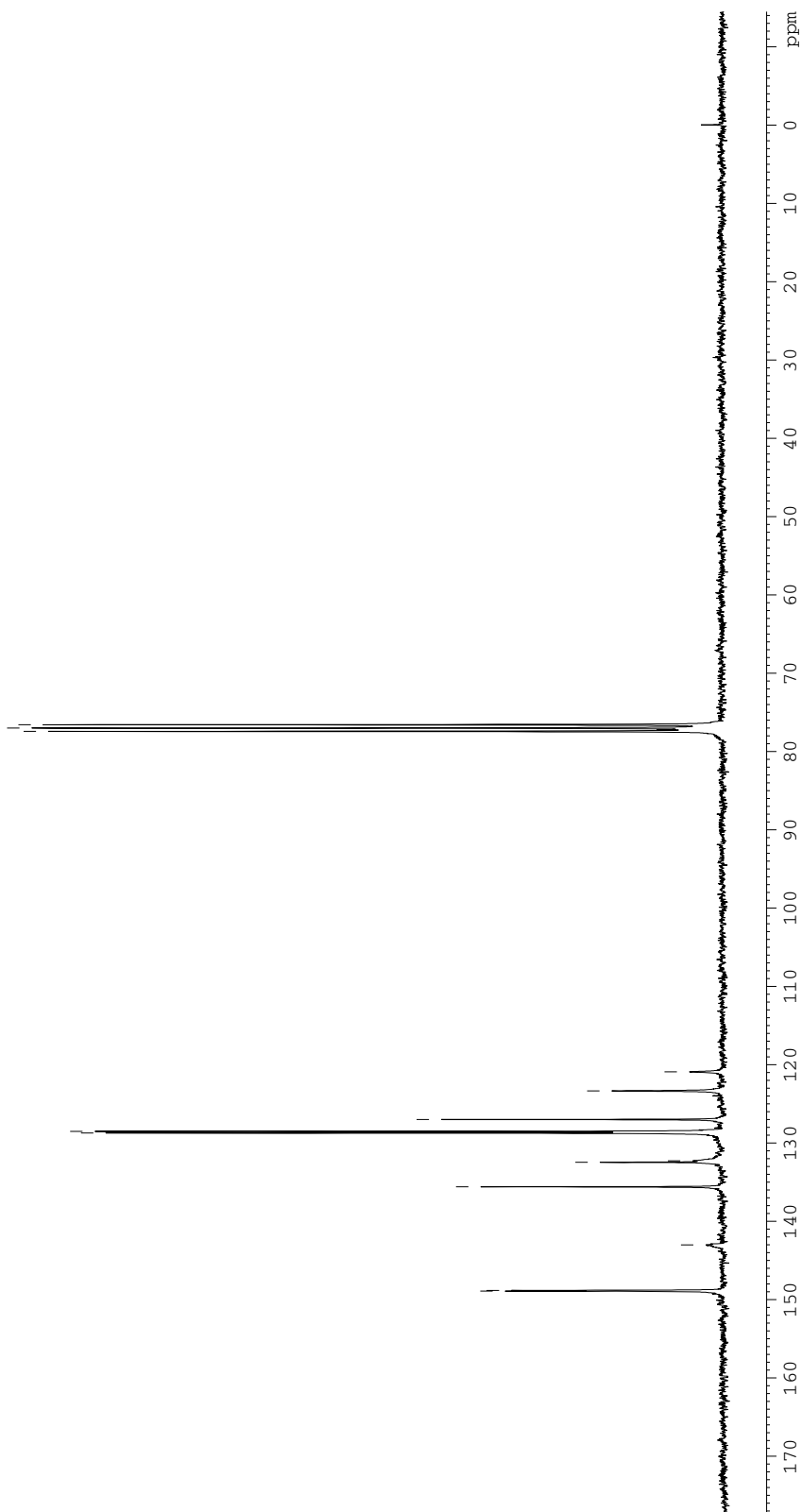

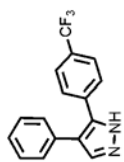

S3

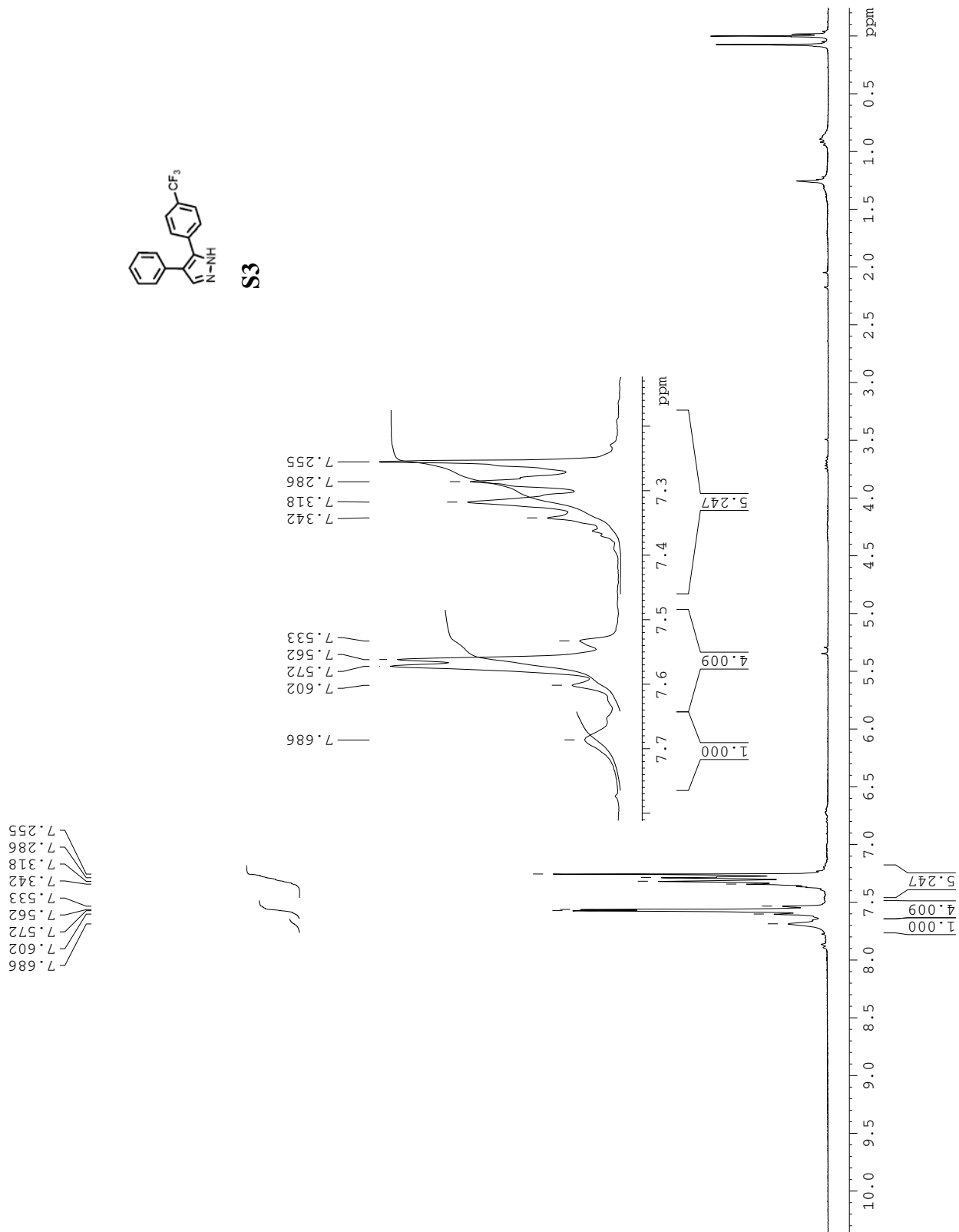



TLJ-1-150 1H 400MHz DMSO-d

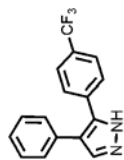

**S3**  
(DMSO-d<sub>6</sub>)

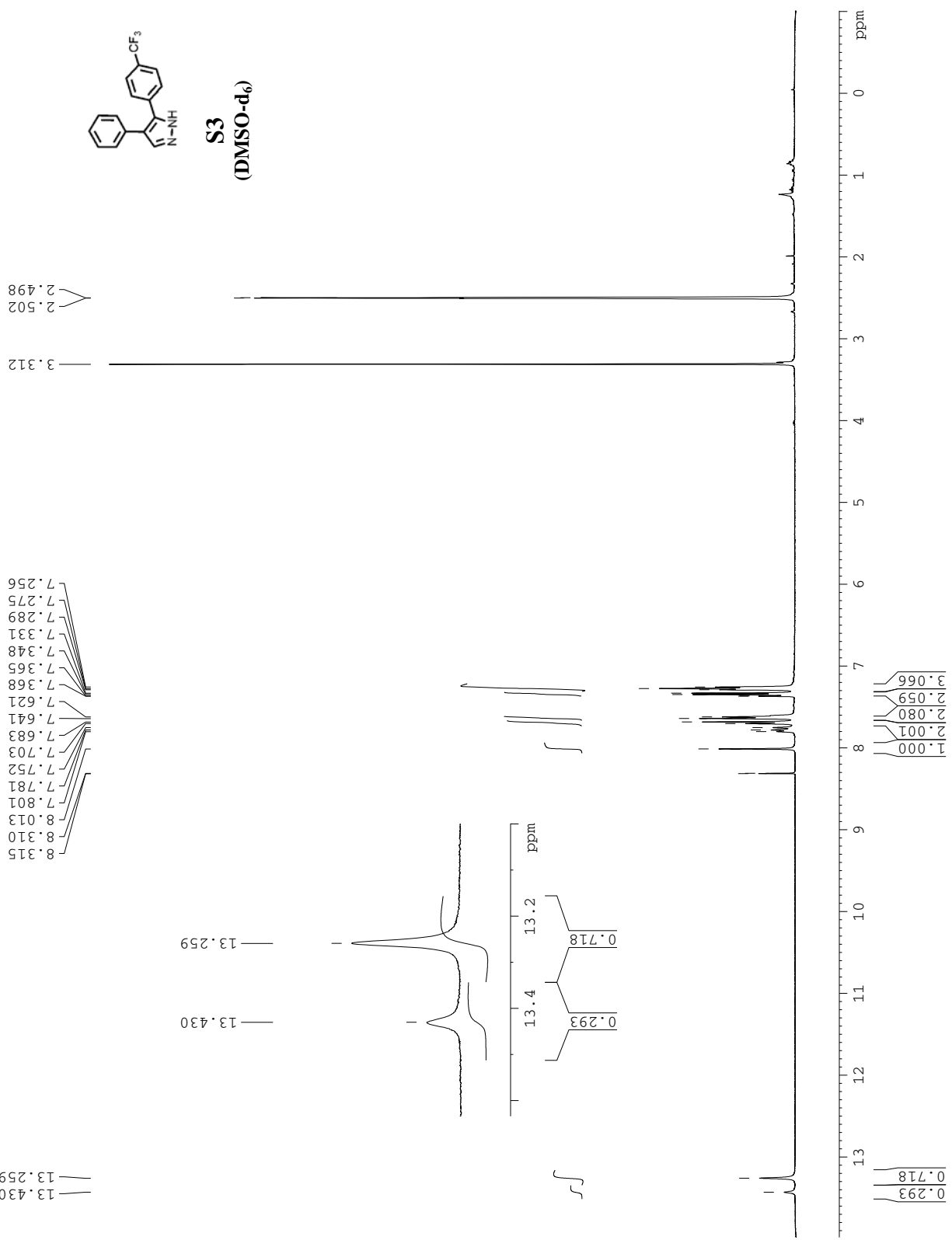

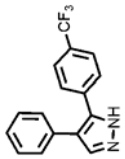

S3

77.316  
76.999  
76.681

135.568  
132.454  
130.127  
129.803  
128.707  
128.618  
128.318  
127.083  
125.491  
125.457  
122.695  
120.919

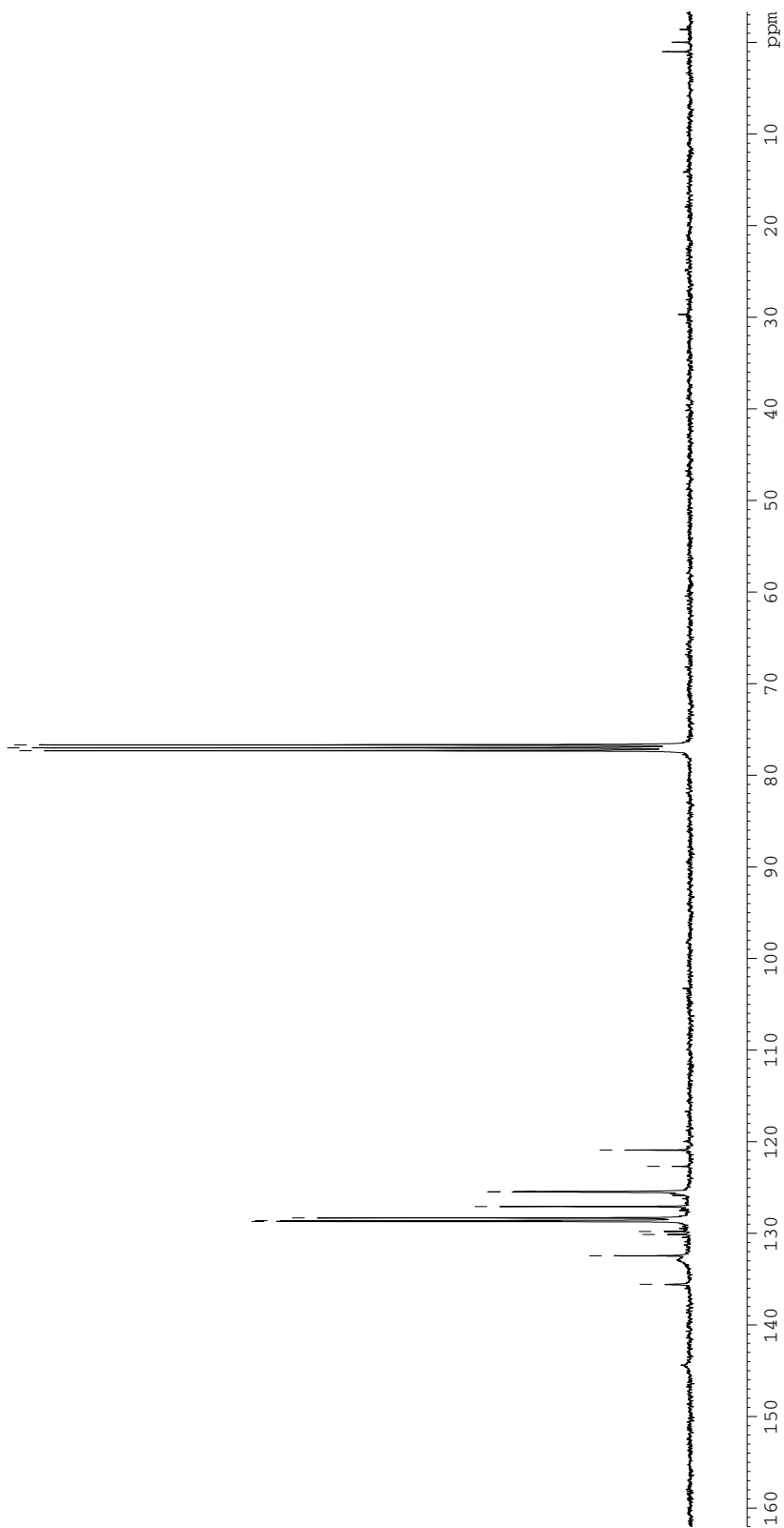

TLJ-2-095 1H NMR 300MHz CDCl3

-0.002

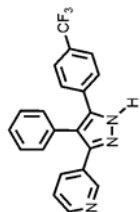

24

8.721  
8.528  
7.623  
7.597  
7.524  
7.495  
7.472  
7.444  
7.345  
7.335  
7.330  
7.324  
7.185  
7.180  
7.176  
7.171  
7.167

7.623  
7.597  
7.524  
7.495  
7.472  
7.444  
7.345  
7.335  
7.330  
7.324  
7.185  
7.180  
7.176  
7.171  
7.167

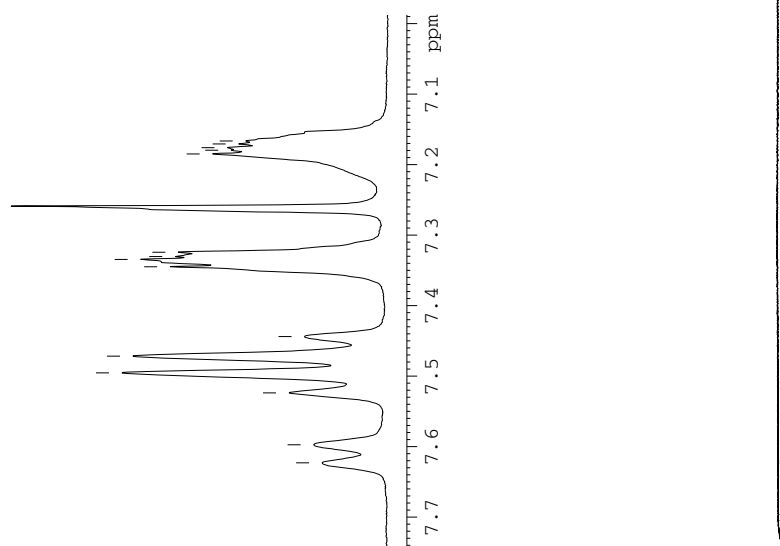

14 13 12 11 10 9 8 7 6 5 4 3 2 1 0 ppm

1.000  
1.000  
2.014  
2.073  
3.062  
3.010

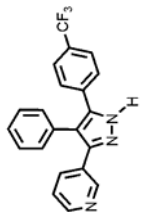

**24**  
(500MHz in  
DMSO-d<sub>6</sub>)

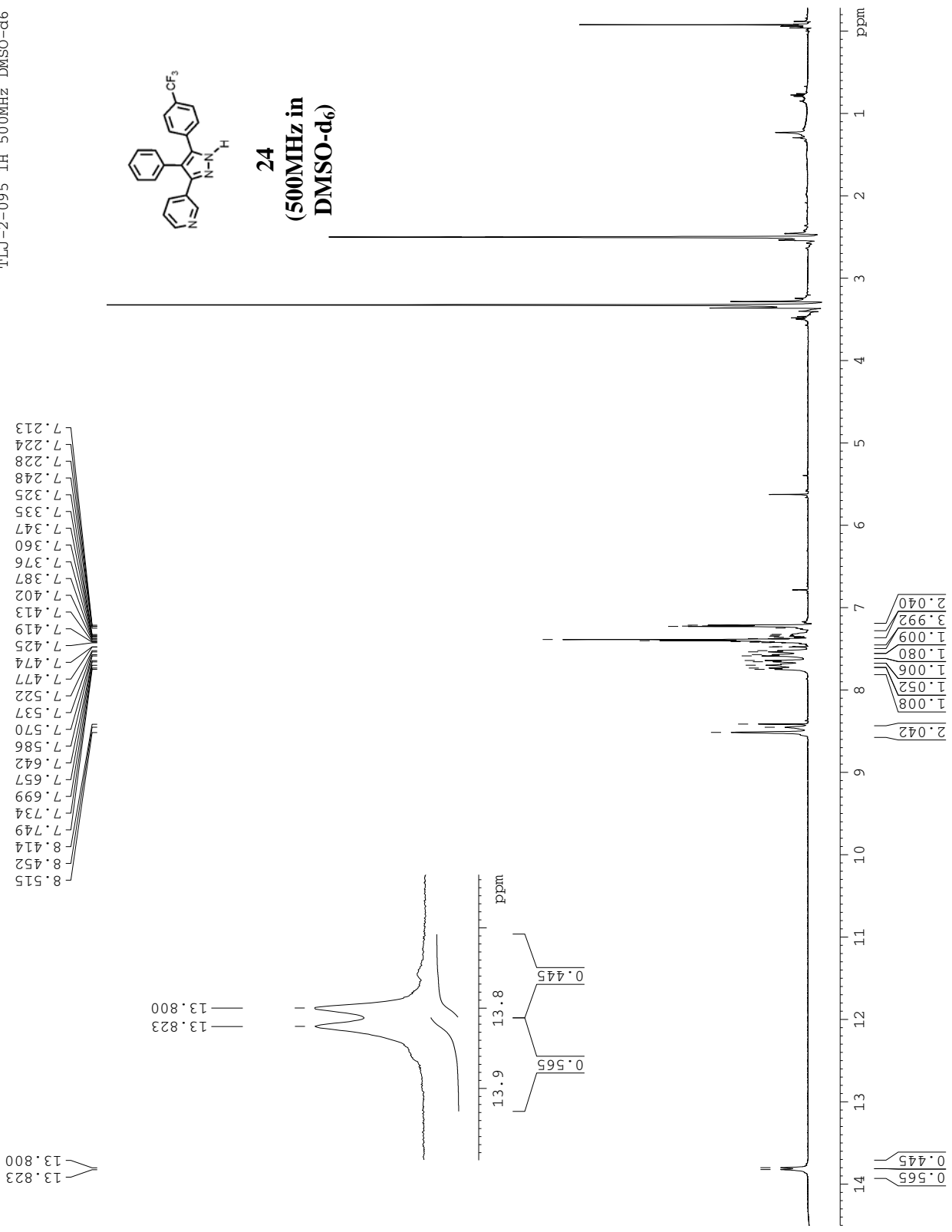

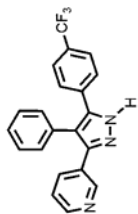

24

148.830  
148.421  
135.193  
134.327  
132.044  
130.432  
130.231  
129.031  
127.820  
127.740  
125.541  
123.406  
119.013  
125.498  
129.812  
129.378  
123.346

135.193  
134.327  
132.044  
130.432  
130.231  
129.031  
127.820  
127.740  
125.541  
123.406  
119.013  
125.498  
129.812  
129.378  
123.346

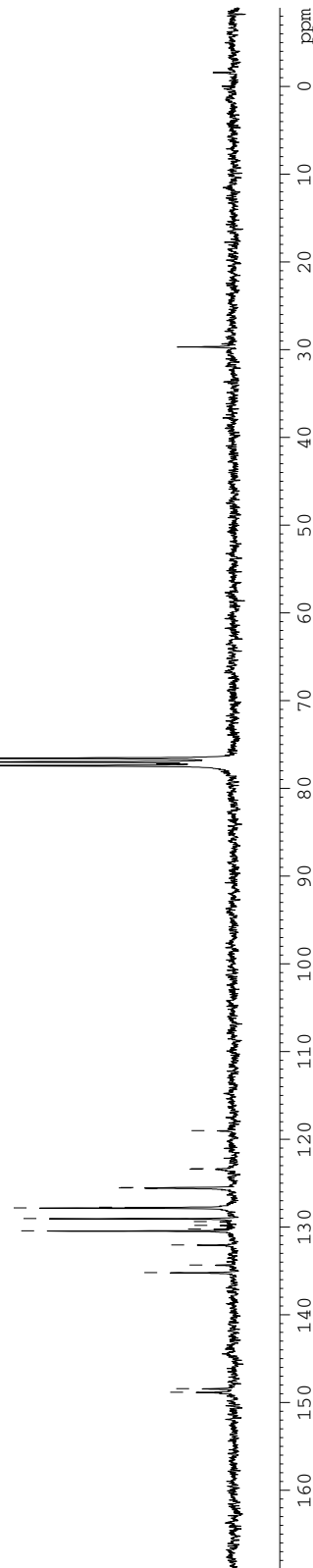
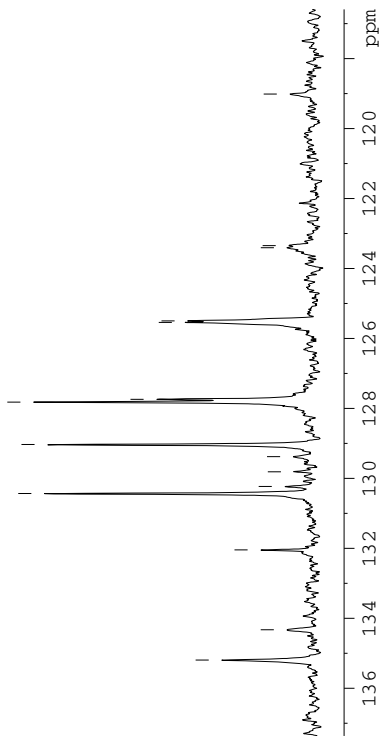



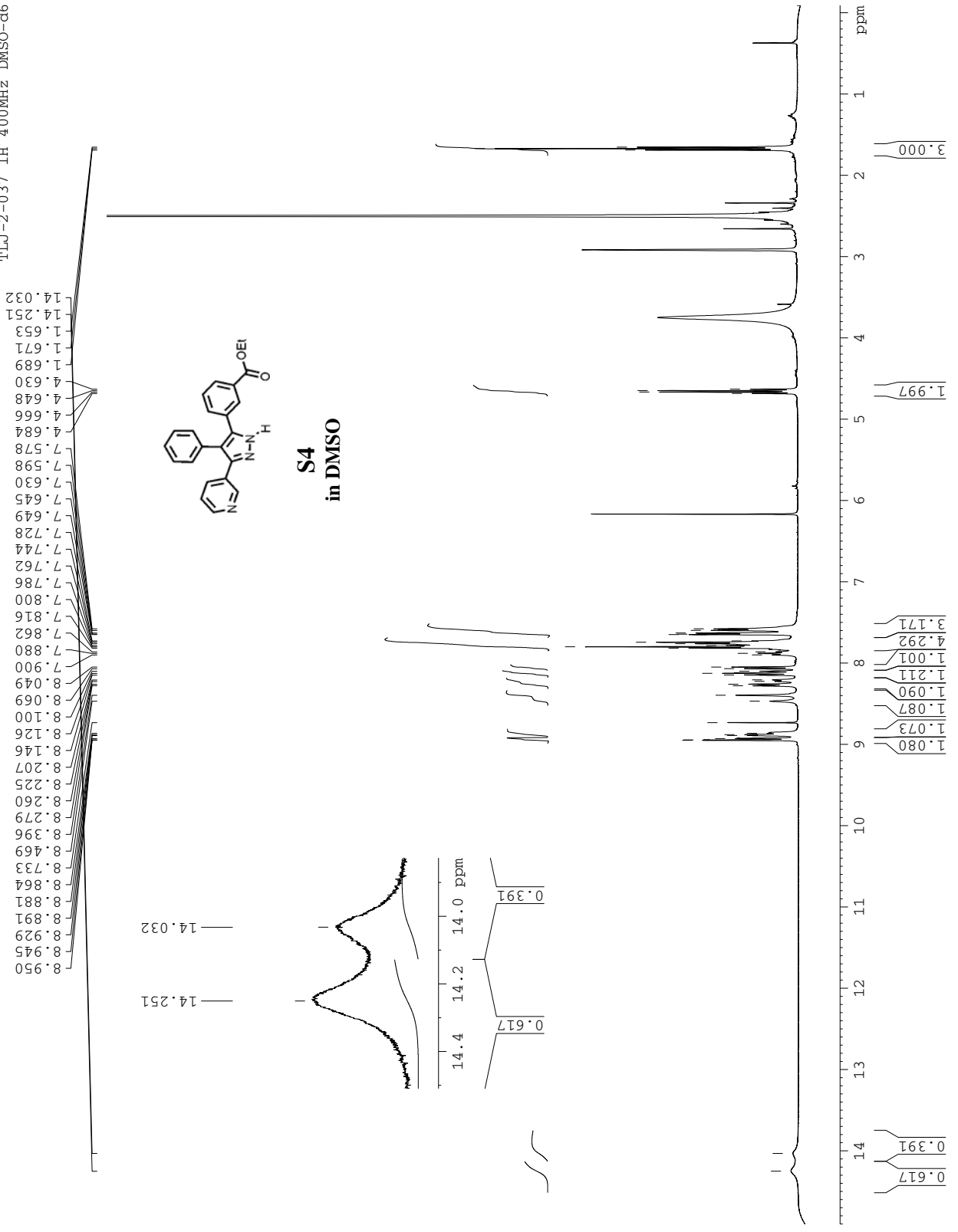

TLJ-2-037 13C 75MHz CDCl3

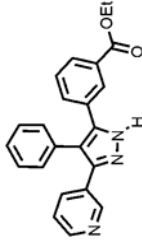

S4

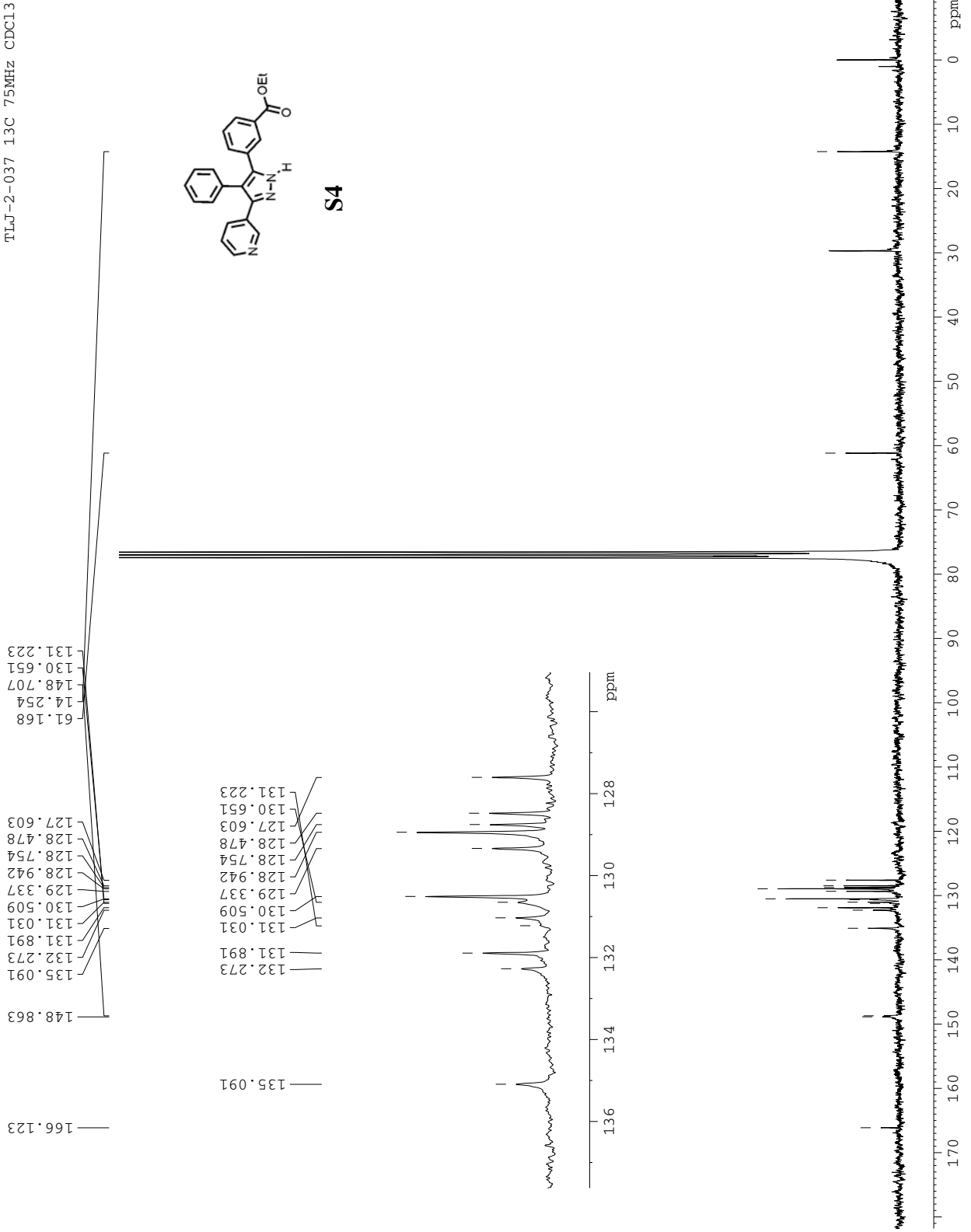



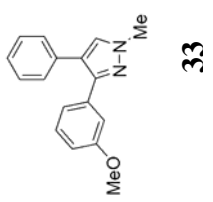
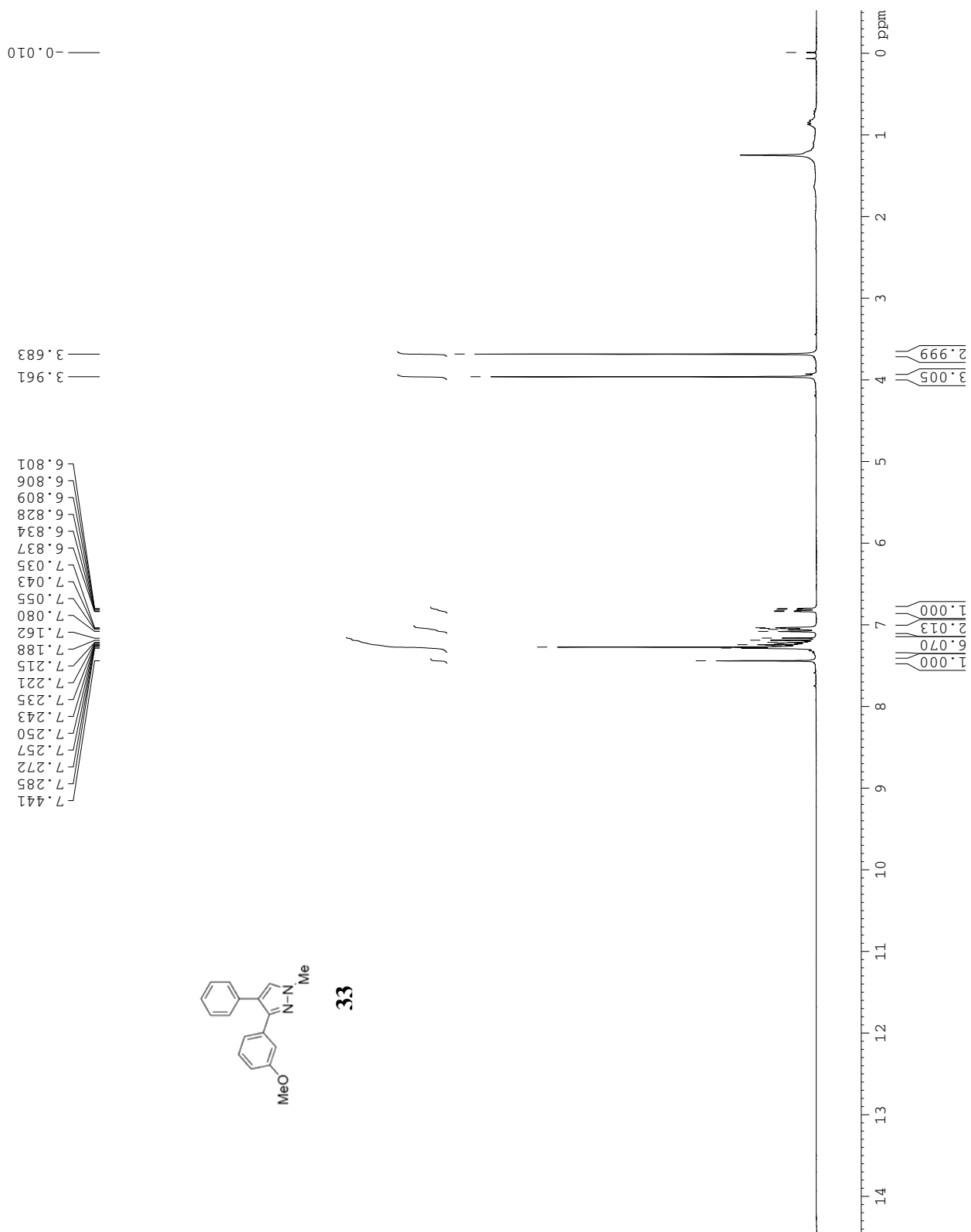

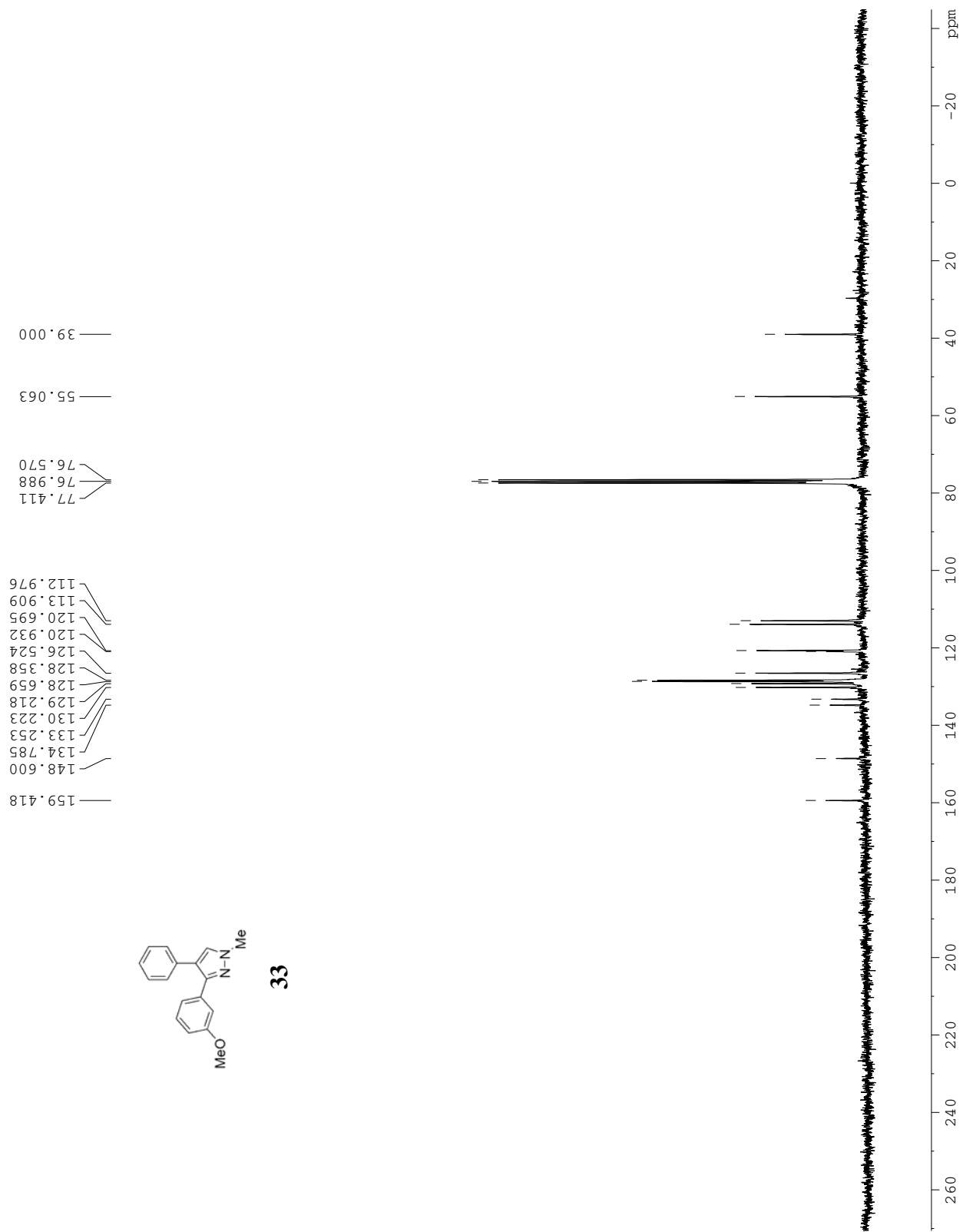

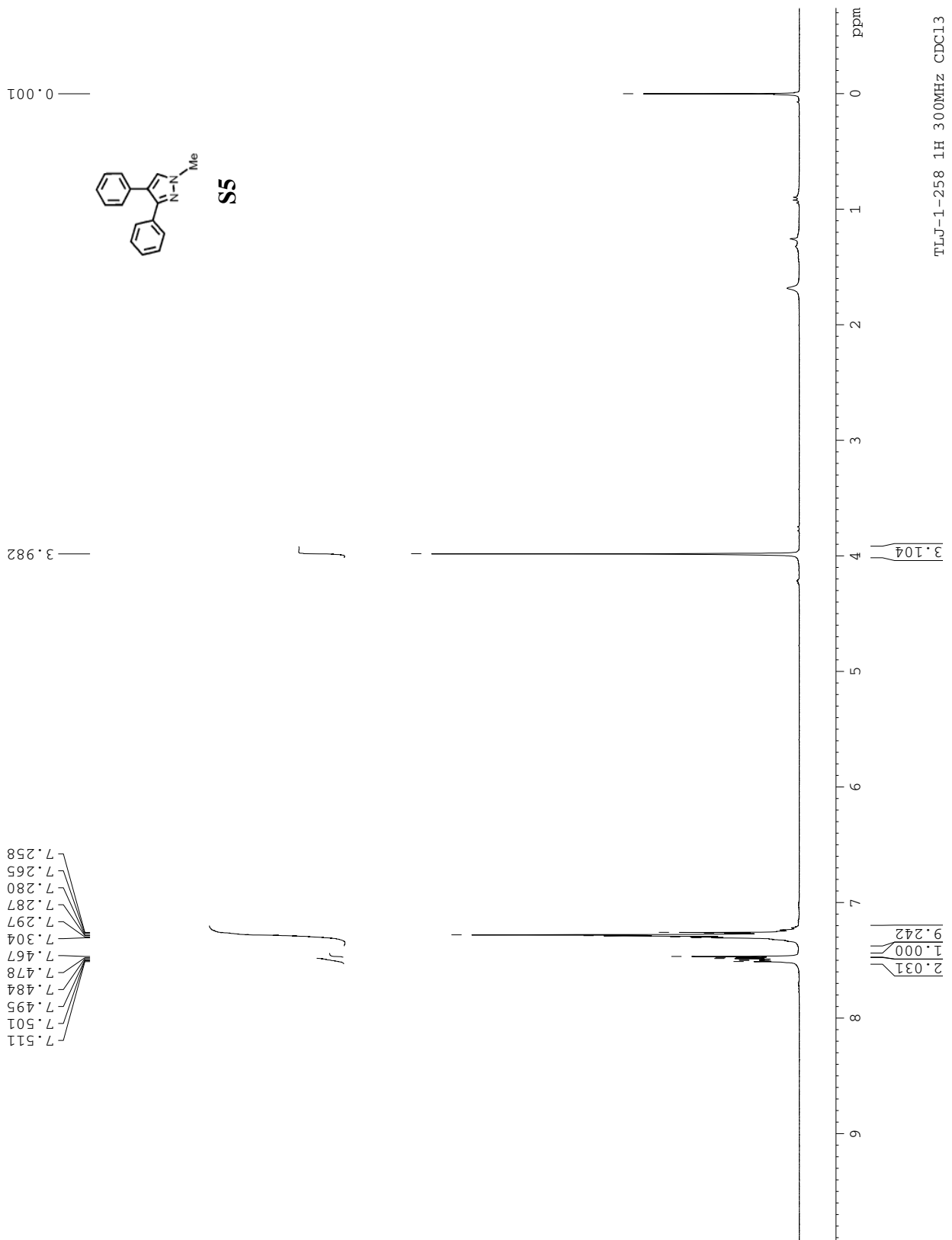

TLJ-1-258 1H 300MHz CDCl3

TLJ-1-258 13C 75MHz CDCl3

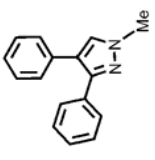

S5

148.763  
133.505  
133.275  
130.896  
130.234  
128.547  
128.421  
128.247  
127.474  
126.492  
120.846

77.426  
77.002  
76.579

39.033

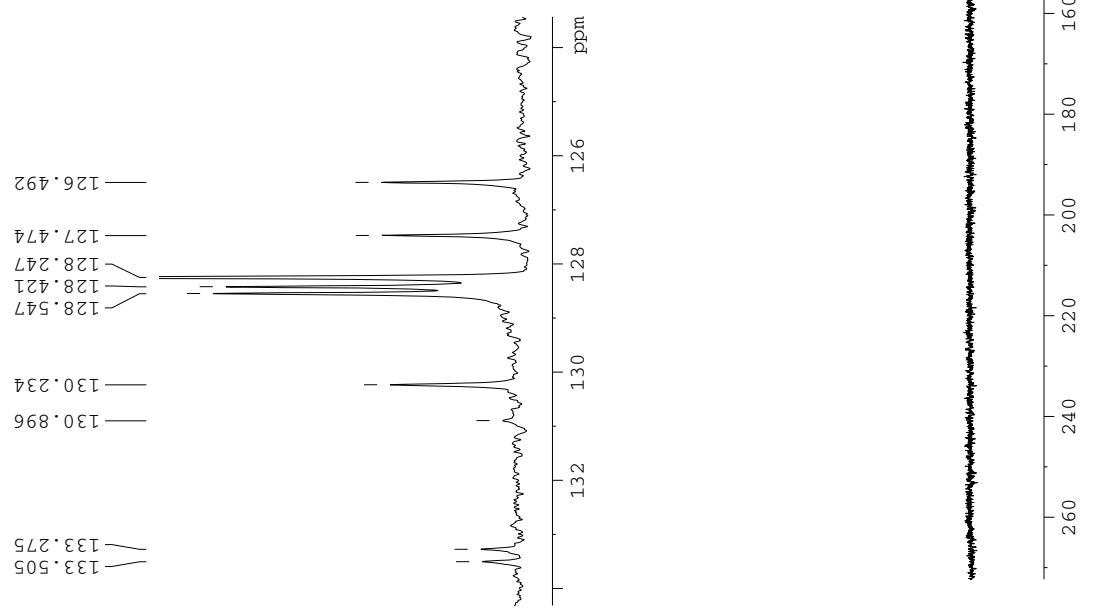

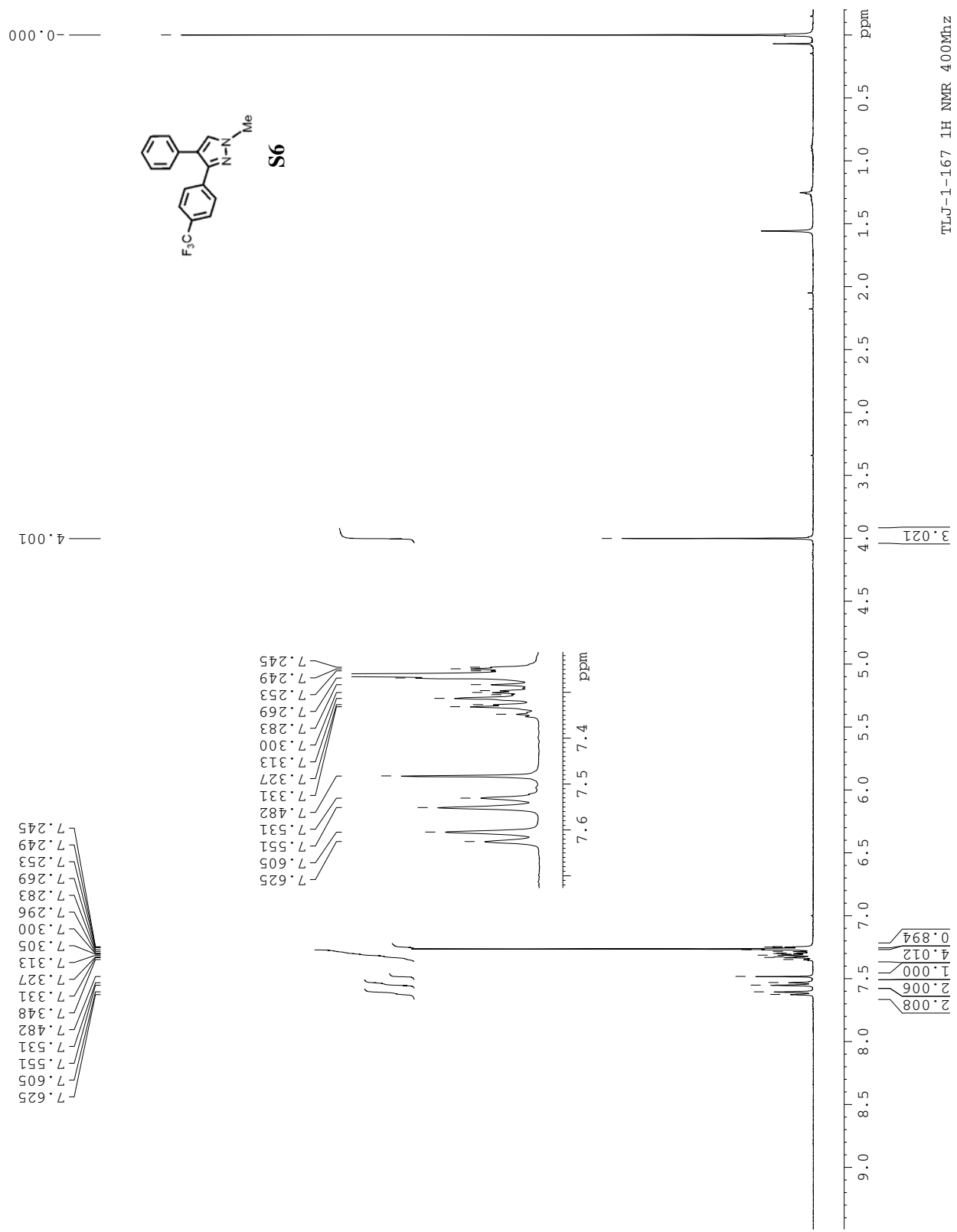

TLJ-1-167 13C 75MHz CDCl3

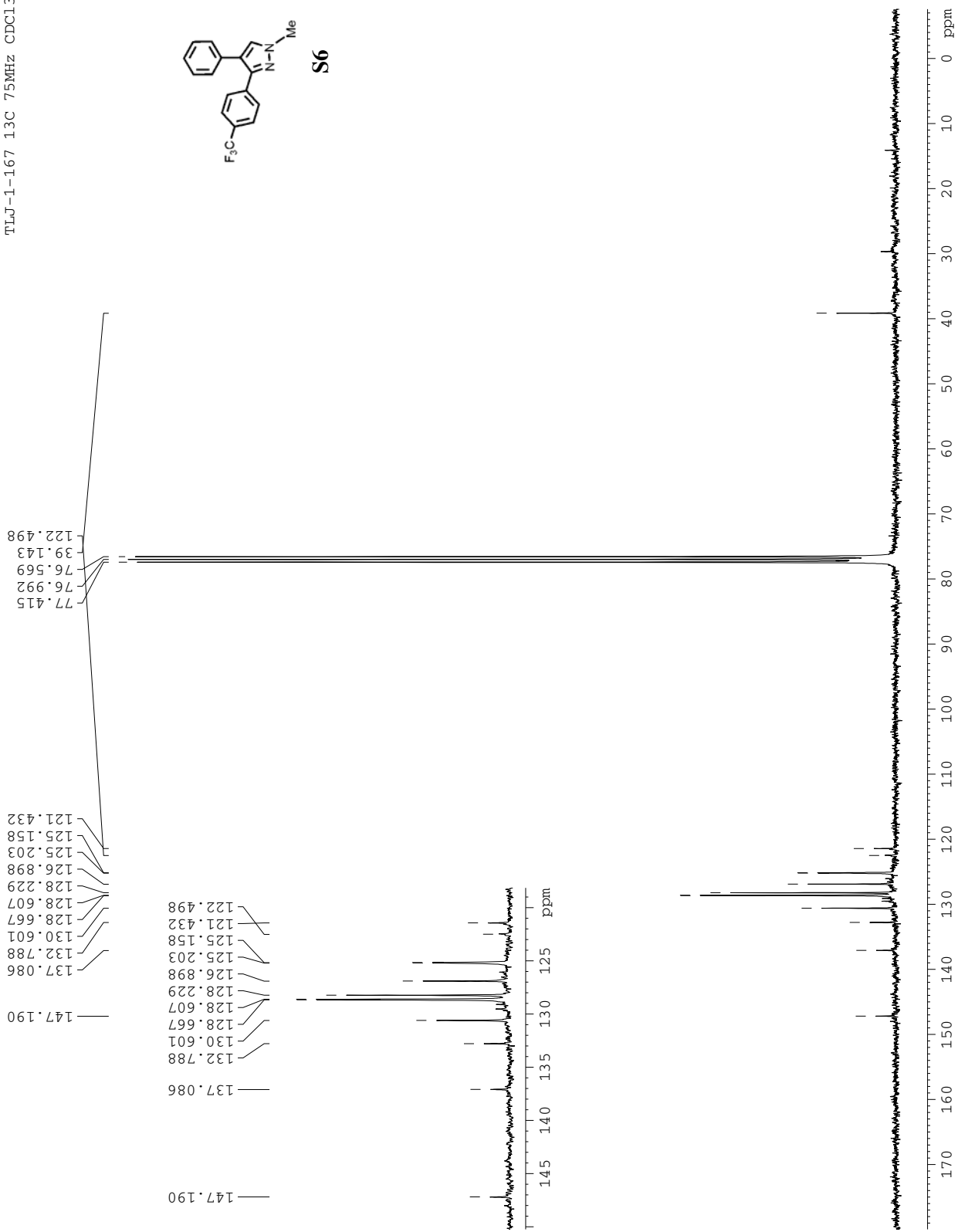
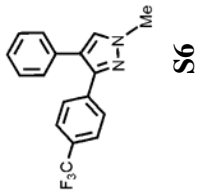

TLJ-1-217 1H NMR 400MHz CDCl3

