

A TBP-containing multiprotein complex (TIF-IB) mediates transcription specificity of murine RNA polymerase I

Dirk Eberhard, Laszlo Tora¹, Jean-Marc Egly¹ and Ingrid Grummt*

Institute of Cell and Tumor Biology, German Cancer Research Center, D-69120 Heidelberg, Germany and ¹Institut de Chimie Biologique, Faculté de Médecine, 11 rue Humann, 67085 Strasbourg cédex, France

Received July 6, 1993; Revised and Accepted August 2, 1993

ABSTRACT

TIF-IB is a transcription factor which interacts with the mouse ribosomal gene promoter and nucleates the formation of an initiation complex containing RNA polymerase I (Pol I). We have purified this factor to near homogeneity and demonstrate that TIF-IB is a large complex (<200 kDa) which contains several polypeptides. One of the subunits present in this protein complex is the TATA-binding protein (TBP) as revealed by copurification of TIF-IB activity and TBP over different chromatographic steps including immunoaffinity purification. In addition to TBP, three tightly associated proteins (TAFs-I) with apparent molecular weights of 95, 68, and 48 kDa are contained in this multimeric complex. This subunit composition is similar—but not identical—to the analogous human factor SL1. Depletion of TBP from TIF-IB-containing fractions by immunoprecipitation eliminates TIF-IB activity. Neither TBP alone nor fractions containing other TBP complexes are capable of substituting for TIF-IB activity. Therefore, TIF-IB is a unique complex with Pol I-specific TAFs distinct from other TBP-containing complexes. The identification of TBP as an integral part of the murine rDNA promoter-specific transcription initiation factor extends the previously noted similarity of transcriptional initiation by the three nuclear RNA polymerases and underscores the importance of TAFs in determining promoter specificity.

INTRODUCTION

Different molecular mechanisms are involved in the process of transcription initiation by the three classes of nuclear RNA polymerases. Class I, II and III RNA polymerase promoters differ not only in their DNA recognition sequences and their overall structural organization but also interact with a distinct set of basic transcription factors that are required for accurate transcription initiation (for review, see 1). These general factors serve in part to precisely position the RNA polymerase at the transcription start site. In addition to specific binding to promoter sequences,

they interact with each other and/or the polymerase to form a productive transcription initiation complex. To understand this process, the function of the factors necessary for initiation by the three classes of nuclear RNA polymerases must be determined.

Transcription initiation of murine ribosomal RNA genes by RNA polymerase I (Pol I) has been shown to require in addition to Pol I four factors, designated TIF-IA, TIF-IB, TIF-IC, and UBF (2). Two of these factors, TIF-IB and UBF, are specific DNA binding proteins which function early in the initiation pathway. Promoter selectivity is conferred by TIF-IB, the basal factor which specifically interacts with the core region of the mouse rDNA promoter and nucleates transcription complex formation (3). Cooperative interaction between TIF-IB and the upstream binding factor UBF has been shown to increase binding of TIF-IB to its target sequence (4). Apparently, UBF recruits TIF-IB to the template which, in turn, allows for higher promoter activity. The association of TIF-IB with the rDNA promoter, in the presence or absence of UBF, creates a primary preinitiation complex that recruits Pol I, either alone or in association with the two auxiliary factors TIF-IA and TIF-IC to the template to form a preinitiation complex (2).

Much previous work has focussed on the functional differences which exist between the transcription apparatus of the different classes of RNA polymerases. Initially it was assumed that each class of polymerases would utilize a distinct set of accessory factors to transcribe its set of genes. However, recent experimental evidence suggest that the different polymerases use similar strategies, and even the same or closely related polypeptides, to transcribe their target genes. First, in yeast at least three subunits are shared between the Pol I, Pol II, and Pol III enzymes (for review, see 5). Second, at least one factor, the TATA-binding protein (TBP), is required for transcription by all three classes of RNA polymerases (6–12). Thus, TBP is a general transcription factor for all nuclear RNA polymerases. Presumably the choice for a given class of promoters is accomplished by association of TBP with other accessory proteins, termed TAFs (for TBP-associated factors). Recent studies utilizing biochemical and immunoaffinity approaches have resulted in the separation of distinct TBP complexes and the identification of specific TAFs

* To whom correspondence should be addressed

whose complexity raises the possibility that different TAFs may be selective for different classes of promoters and for distinct regulatory factors. In fact, TAFs that are distinct from each other were identified in at least two chromatographically distinct populations of TFIID which respond to different transcription activators (13, 14). Recent data have indicated that the Pol III-specific factor TFIIB consists of TBP and specific associated factors (for review, see 15). Furthermore, TBP has also been shown to be a component of SL1, the human factor that is most likely homologous to the murine factor TIF-IB (9). Therefore, it seems that utilization of TBP by all three RNA polymerases is strongly conserved.

An unusual property of ribosomal gene transcription is the species-specificity of promoter recognition (16). This species-specificity has been shown to be mediated in the human system by SL1 and in the mouse system by TIF-IB (17–20). It is not known which of the different polypeptides is involved in promoter recognition and is responsible for the species-specific differences of this central Pol I transcription factor. To elucidate the molecular mechanisms which direct promoter recognition of murine Pol I, we have purified TIF-IB to near homogeneity. We demonstrate that—analogue to the human factor SL1—TIF-IB behaves as a macromolecular complex consisting of TBP and three associated proteins whose molecular weights are similar but not identical to its human counterpart.

MATERIALS AND METHODS

Partial purification of transcription factors and *in vitro* transcription assays

200 ml of a mixture of nuclear and cytoplasmic extracts were chromatographed on DEAE-Sepharose CL-6B, followed by Heparin-Ultrogel. Partial separation of individual factor activities was obtained by step-elution with buffer AM (20 mM Tris-HCl, pH 7.9, 0.1 mM EDTA, 20% glycerol, 5 mM MgCl₂, 1 mM DTE, 0.5 mM PMSF) containing different salt concentrations. TIF-IA and TIF-IC eluted at 200 mM KCl, Pol I and UBF at 400 mM KCl, and TIF-IB at 600 mM KCl. The H-200 fraction was further purified by chromatography on Q-Sepharose (300 mM). *In vitro* transcription reactions (25 μ l) contained 10–50 ng of template DNA (pMrWT/Nde I) and a mixture of crude Pol I (H-400 fraction), partially purified TIF-IA and TIF-IC (Q-Sepharose fraction), and TIF-IB at different stages of purification. The cell-free transcription system and the analysis of the RNA has been described elsewhere (21, 22).

Purification of TIF-IB

A typical purification of TIF-IB started from about 6×10^{10} cultured Ehrlich ascites cells which were harvested in the exponential phase of growth. 600 ml of a mixture of nuclear and cytoplasmic extracts were purified by chromatography on DEAE-Sepharose, Heparin-Ultrogel, CM-Sepharose, and Mono-S as described (3). TIF-IB was eluted from the Mono-S column with a salt gradient from 0.3 to 0.7 M KCl. Fractions containing TIF-IB activity (eluting at 450 mM KCl) were pooled and used for affinity purification.

Sedimentation velocity centrifugation

TIF-IB (200 μ l of a Mono-S fraction) was layered onto a 3.5 ml linear (20–40%) glycerol gradient containing 3% sucrose in buffer AM-100 and centrifuged in a SW60 rotor at 55,000 rpm for 14 h at 4°C. 200 μ l fractions were collected and assayed

in the reconstituted transcription system. 100 μ l of each fraction were precipitated with 10% TCA and, after SDS-PAGE, TBP was detected by immunoblotting. Molecular mass standards used for estimation of the native molecular weight of TIF-IB were catalase (240 kDa), lactate dehydrogenase (140 kDa), albumin (66 kDa) and carbonic anhydrase (31 kDa) which were run on a parallel gradient.

Western blotting

Western blotting was performed by transferring proteins separated by SDS-PAGE to nitrocellulose filters. Nonspecific interaction of the antibody was prevented by blocking the filters for 1 h in phosphate-buffered saline containing 2.5% nonfat dry milk and 0.05% Tween-20. A monoclonal antibody raised against the N-terminal region of hTBP (mAB3G3, ref. 14) was diluted 1:2,000 into the same buffer without Tween-20. After incubation for 1 h, the filter was washed and incubated in a 1:2,500 dilution of horseradish peroxidase-conjugated anti-mouse IgG antibody (Promega). Signals were detected using the ECL system (Amersham) according to the manufacturer's instructions. The same procedure was also applied for immunoblots using the monoclonal antibody 1TA which was directed against a Pol II-specific TAF (TAFII-100) with an apparent molecular mass of about 100 kDa (manuscript in preparation).

Affinity purification of the Pol I-specific TBP-TAF complex

The monoclonal antibodies (3G3) reacting with the first 17 amino acids of recombinant human TBP were coupled to protein A-Sepharose CL-4B and crosslinked with dimethylpimelimidate as

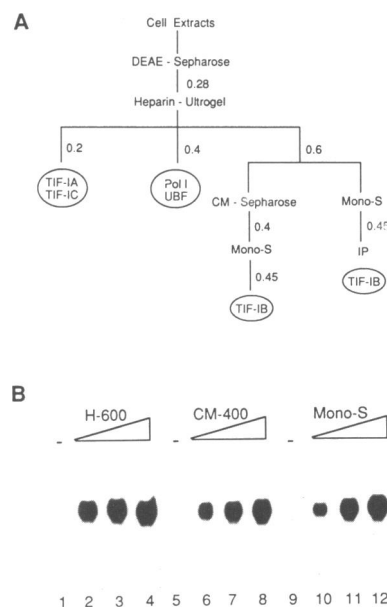

Figure 1. Assay for TIF-IB activity. **A)** Diagram illustrating the fractionation scheme used to separate individual factors. The numbers refer to the molar KCl concentrations used for elution. **B)** Transcription complementation assay used for monitoring TIF-IB activity. The assays contained a crude Pol I fraction (H-400 plus H-200 fraction, lanes 1, 5, 9) and increasing amounts of TIF-IB at different stages of purification. 0.5, 1.5 and 3 μ l of fractions eluted from the Heparin column at 600 mM KCl (H-600, lanes 2–4), 0.5, 1.5 and 3 μ l of fractions eluted from CM-Sepharose at 400 mM KCl (CM-400, lanes 6–8), and 0.1, 0.5 and 1 μ l of fractions separated on a Mono-S FPLC column (Mono-S, lanes 10–12) were assayed.

described (23). All solutions used for immunoprecipitation reactions contained the following set of protease inhibitors: aprotinin (5 $\mu\text{g/ml}$), pepstatin (5 $\mu\text{g/ml}$), leupeptin (5 $\mu\text{g/ml}$), benzamidinhydrochloride (2 mM), antipain (2 $\mu\text{g/ml}$) and chymostatin (2 $\mu\text{g/ml}$). For pre-clearing, 2 ml of pooled Mono-S fractions containing TIF-IB activity were preincubated with 100 μl of protein A-Sepharose at 4°C for 1 h in buffer AM-100 supplemented with 0.1% NP-40. After centrifugation at 2,000 rpm, the supernatant was transferred to a tube containing 0.1 ml of coupled mAB3G3 affinity resin and incubated at 4°C for 3 h with gentle agitation. The coupled antibody-protein A complexes were pelleted by centrifugation and then washed four times with 0.7 M KCl, 5 mM MgCl₂, 20 mM Tris-HCl (pH 7.9), 0.1 mM EDTA, 20% glycerol, 0.1% NP-40 and twice with buffer AM-100. The immunoprecipitated TIF-IB complex was eluted by addition of a 1,000-fold excess of the peptide PA81 (14) for 3 h at 4°C with rotation. After centrifugation, the eluate was collected and assayed for transcriptional activity.

RESULTS

The experimental system to purify TIF-IB

To establish a convenient assay for monitoring TIF-IB activity throughout the individual purification steps, we fractionated cell extracts from cultured mouse cells according to the scheme depicted in Figure 1A. The first steps of the purification procedure involved chromatography on DEAE-Sepharose and Heparin-Ultrogel. Step-elution on the Heparin column separates the components of the Pol I transcription system into three fractions which are required to reconstitute transcription (3). Under the experimental conditions applied, factors TIF-IA and TIF-IC do not bind to the column and, therefore, are found in the 200 mM KCl step (H-200). The H-400 fraction contains Pol I and UBF, whereas TIF-IB is contained in the H-600 fraction. The H-200 and H-400 fraction did not exhibit any transcriptional activity neither on their own (data not shown) nor in combination (Fig. 1B, lanes 1, 5, 9). This fraction (a mixture of H-200 and

H-400) will be referred to as crude Pol I fraction. When the H-600 fraction or further purified TIF-IB fractions (CM-400, Mono-S) were added to this crude Pol I fraction, specific transcription was restored in a concentration-dependent manner (Fig. 1B). At optimal TIF-IB concentration, a 100-fold stimulation of transcription was observed which emphasizes the central role of TIF-IB in transcription initiation from the mouse rDNA promoter.

TIF-IB sediments as a 200 kDa protein complex which contains TBP

To determine the native molecular mass, the sedimentation of TIF-IB was analyzed by glycerol gradient centrifugation. As shown in Figure 2A, TIF-IB activity sedimented slightly faster than lactate dehydrogenase. Thus TIF-IB behaves like a protein or a polypeptide complex with an apparent molecular mass of approximately 200 kDa (Fig. 2A). Since it has been shown before that the functionally homologous human factor SL1 represents a multisubunit complex with one of the subunits being TBP (9), we tested for the presence of TBP in the active TIF-IB fractions by Western blot analysis (Fig. 2B). The peak of TIF-IB activity precisely coincided with the peak of TBP protein. Because murine TBP is a 35 kDa monomer (24), this result indicates that TIF-IB contains TBP which appears to be associated with additional protein(s).

The coincidence of TIF-IB activity with the presence of TBP in the glycerol fractions prompted us to determine whether the two activities remained within one complex, or were separable by chromatography in the presence of 2 M urea. Figure 3 shows the distribution of TIF-IB activity and TBP in fractions eluted from a Mono-S FPLC column with a linear salt gradient (from 300 to 700 mM KCl) in the presence of 2 M urea. Both on this column and after fractionation on a Mono-Q FPLC column (data not shown), TIF-IB activity persistently copurified with TBP. Thus, TBP appears to be an integral component of TIF-IB.

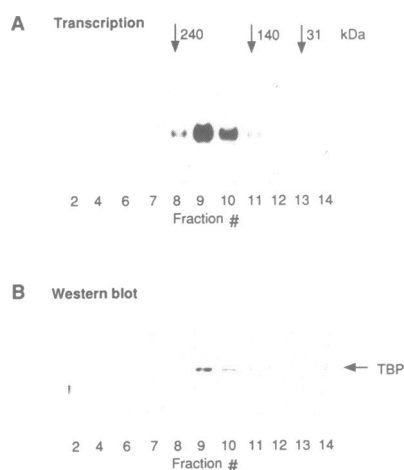

Figure 2. Glycerol gradient sedimentation analysis of TIF-IB. 200 μl of a Mono-S fraction were centrifuged in a SW60 rotor at 55,000 rpm for 14 h at 4°C on a 3.5 ml linear (20–40%) glycerol gradient. 200 μl fractions were collected, and aliquots were assayed in the reconstituted transcription system (A) or on immunoblots using TBP antibodies (B). The positions of molecular mass standards run on a parallel gradient are marked by arrows.

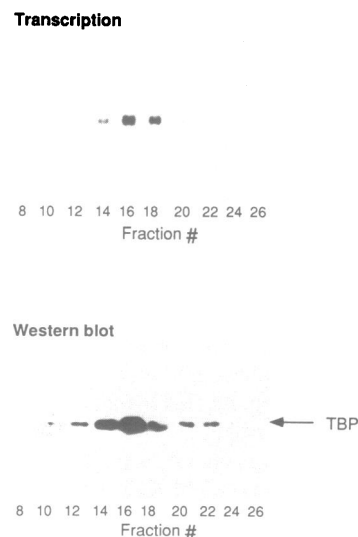

Figure 3. Co-purification of TIF-IB activity and TBP under denaturing conditions. TIF-IB (CM-400 fraction) was fractionated on a Mono-S FPLC column in the presence of 2 M urea using a salt gradient from 0.3 to 0.7 M KCl. After dialysis, 0.2 μl of each fraction were assayed for TIF-IB activity in the reconstituted transcription system (top), or for TBP by Western blotting using mAB3G3 (bottom). The peak of TIF-IB activity eluted at 450 mM KCl.

Heat-inactivation of TIF-IB

It has been reported that mild heat treatment eliminates TBP activity in HeLa cell nuclear extracts (25). Transcriptional activity of such heat-treated extracts could be restored by recombinant TBP (11, 26). To investigate whether TBP inactivation will eliminate TIF-IB activity, TIF-IB was incubated for 15 min at various temperatures before assaying in the reconstituted transcription system. In parallel, the heat sensitivity of recombinant human TBP (hTBP) was monitored in a Pol II transcription assay containing the adenovirus major late promoter and HeLa extract which was depleted of TFIID by chromatography on phosphocellulose. Addition of hTBP to the depleted extract restored Pol II transcription to levels similar to those obtained with untreated extract (data not shown). TIF-IB directed Pol I transcription was inactivated with the same kinetics as TFIID-dependent transcription on the adenovirus major late promoter (Fig. 4, lanes 1–6). Addition of untreated TIF-IB rescued transcriptional activity (lane 8). However, in contrast to the Pol II system, specific Pol I transcription could not be recovered by supplementing the assays with recombinant human TBP (lane 7). Actually, addition of hTBP to the Pol I system was inhibitory. A similar inhibitory effect of excess of TBP has also been observed in other systems (27, 28). Thus, this effect is probably specific and not attributable to a bacterial protein contaminant. Nevertheless, the finding that TIF-IB exhibits the same temperature sensitivity as TBP but cannot be restored by exogenous TBP suggests that besides TBP another subunit of TIF-IB was inactivated by the heat treatment. Alternatively, the failure to reconstitute transcription by TBP may reflect insufficient assembly of the Pol I-specific TBP-TAF complexes after inactivation of endogenous TBP.

hTBP antibodies deplete TIF-IB activity

In an attempt to prove more directly that TBP is part of TIF-IB activity and to identify the murine Pol I-specific TBP-associated proteins, we tried to immunoprecipitate TIF-IB with anti-TBP antibodies (Fig. 5A). The polyclonal antibodies were raised against recombinant human TBP. In the experiment shown in Figure 5A, TIF-IB was first incubated with anti-hTBP before the antigen-antibody complexes were removed by coupling to

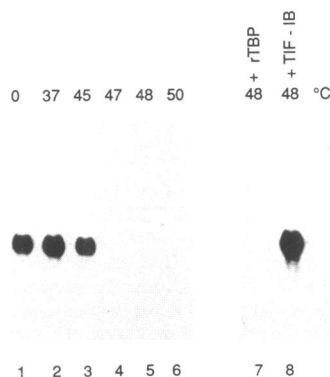

Figure 4. Heat inactivation of TIF-IB. TIF-IB (CM-400 fraction) was incubated for 15 min at the temperatures indicated above the lanes before being tested for transcriptional activity in the reconstituted system (lanes 1–6). In lanes 7 and 8, the assays containing heat-inactivated TIF-IB were supplemented with either recombinant human TBP (rTBP) or with TIF-IB.

protein G-Sepharose beads. Then the supernatant from the immunoprecipitation reaction was assayed for TIF-IB activity. Incubation of TIF-IB with the TBP-antibodies resulted in an almost complete loss of transcriptional activity (compare lanes 1 and 2). Again, this inhibition could be overcome by supplementing the reactions with additional TIF-IB (lane 3), but not with recombinant TBP (lane 4). Control depletions with unrelated antibodies had essentially no effect on TIF-IB activity (lane 5).

To investigate whether the observed effects on Pol I transcription correlate with the specific removal of TBP, the relevant fractions were analyzed for the presence of TBP by immunoblotting. In agreement with the data shown above, TBP was present in the TIF-IB fraction used for immunoprecipitation (lane 1). After incubation with the anti-TBP antibodies, this signal was not detected any more indicating that the antibodies have effectively removed TBP (lane 2). Depletion of TIF-IB with control serum caused a slight drop in the TBP signal, presumably due to dilution effects (lane 3). The quantitative correspondence between TIF-IB-mediated transcriptional activity and the amount of TBP suggests that TBP is not copurifying with TIF-IB by coincidence but is a *bona fide* component of this factor.

Precipitation of TIF-IB polypeptides by TBP antibodies

The following immunoprecipitation experiments were performed with a monoclonal antibody (3G3) which recognized the first 17 amino acids of TBP. Thus, by using an excess of a synthetic peptide (PA81) encompassing these 17 amino acids, TBP and its associated proteins can be efficiently eluted in its native state from immunoprecipitates (14). To identify the subunit composition of TIF-IB, partially purified TIF-IB (Mono-S fraction) was affinity purified with TBP antibodies covalently linked to protein A-Sepharose. After extensive washing, bound proteins were eluted with the PA81 peptide, and analyzed by gel electrophoresis (Fig. 6A) and by Western blotting (Fig. 6B). The

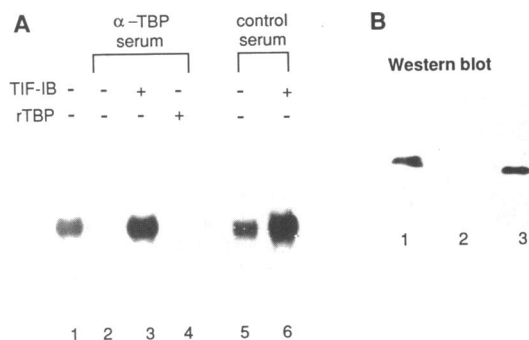

Fig. 5. Immunoprecipitation of TIF-IB with anti-TBP antibodies. **A)** Pol I transcription is inhibited by TBP depletion. 30 μ l of partially purified TIF-IB (CM-400) were incubated with 1 μ l of polyclonal anti-TBP serum (lanes 2–4) or with control serum (lanes 5 and 6). After incubation for 1.5 h at 4°C, the reactions were transferred to microtubes containing 10 μ l of hydrated protein G-Sepharose and incubated for 1 h at 4°C. The supernatants of the immunoprecipitation reaction were tested in the standard transcription assay in the absence of additional factors (lanes 2 and 5), or in the presence of TIF-IB (lanes 3 and 6) and recombinant TBP (lane 4). Lane 1 shows the activity of the undepleted TIF-IB fraction. **B)** Western blot. The TIF-IB fraction used for immunoprecipitation (lane 1) and the supernatants of the reactions treated with the anti-TBP serum (lane 2) or the control serum (lane 3) were analyzed by immunoblotting using mAB3G3.

silver-stained protein gel shows that besides contaminating BSA and keratin bands migrating around 65 kDa, there are three prominent polypeptides with approximate molecular masses of 95, 68, and 48 kDa which were eluted together with TBP from the immunoprecipitate (Fig. 6A, lane 8). The molar ratio of these individual polypeptides was identical in several TIF-IB preparations indicating that they are integral parts of TIF-IB. None of these three polypeptides was observed when the immunoprecipitates were eluted with a non-specific peptide (data not shown). Thus these three polypeptides represent murine Pol I-specific TBP associated factors, i.e. TAFs-I.

To determine the transcriptional activity of affinity-purified TIF-IB, increasing amounts of the immunoprecipitate were tested in the reconstituted transcription system. Both in the crude Pol I system (Fig. 6C) or in the presence of highly purified factors (Fig. 6D), the TBP-TAF complex stimulated Pol I transcription similar to the activity observed with conventionally purified TIF-

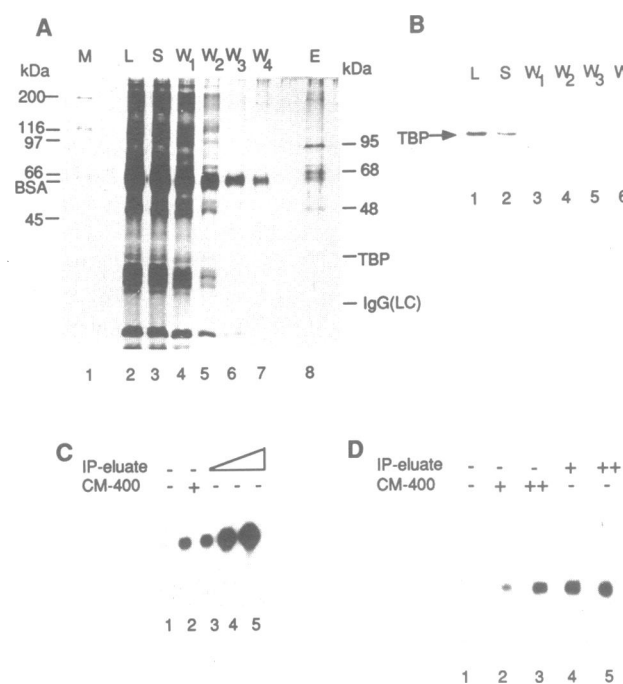

Figure 6. The immunopurified TBP-TAF complex is TIF-IB. **A)** Polypeptide composition of affinity-purified TIF-IB. 200 μg of a partially purified TIF-IB fraction (Mono-S fraction) were immunoprecipitated with mAB3G3 coupled to protein A-Sepharose. Precipitated TBP and associated proteins were eluted with an epitope-specific peptide. To prevent unspecific binding of TIF-IB to Sepharose, the immunoprecipitation was performed in the presence of BSA. The polypeptides present in the load (L), the supernatant (S), the first four wash steps (W₁₋₄), and the eluate (E) were separated by 10% SDS-PAGE and visualized by silver staining. The position of the molecular weight standards (M) and of BSA are indicated. **B)** Western blot. The TIF-IB-containing Mono-S fraction (L), the supernatant of the immunoprecipitation (S), different wash steps (W₁₋₄), and the eluate of the immunoprecipitate (E) were separated by 10% SDS-PAGE and analyzed on Western blots using 3G3 anti-TBP antibodies. **C)** Transcriptional activity of affinity-purified TIF-IB in a partially purified reconstituted system. 1.5 μl of TIF-IB (CM-400 fraction, lane 2) and increasing amounts (0.08, 0.2, and 1 μl) of the IP-eluate (lanes 3-5) were assayed for transcriptional activity in the presence of a crude Pol I fraction (H-200 and H-400 fractions). **D)** Transcriptional activity of affinity-purified TIF-IB in a highly purified reconstituted transcription system. The same fractions as those shown in (C) were compared in a reconstituted assay containing highly purified Pol I, TIF-IA, TIF-IC and UBF each of which was purified on at least five chromatographic columns (2).

IB. Thus the TBP-TAF complex functionally substitutes for TIF-IB, a finding which suggests that TBP together with three TAFs represent the polypeptide composition of the murine Pol I transcription factor TIF-IB.

The Pol I-specific TBP-TAF complex is distinct from Pol II-specific complexes

The size of the largest TIF-IB subunit is very similar to the 95–100 kDa TAF-II (TAF_{II}-100) present in mammalian TFIID complexes (29, 30). Pol I-specific TBP-TAF complexes constitute only a minor fraction (less than 5%) of cellular TBP containing protein complexes, and therefore even small contaminations by Pol II or III-specific TBP-TAF complexes could distort the protein composition of TIF-IB fractions. Although the employed fractionation scheme separated TIF-IB activity from the vast majority of TFIID (data not shown), we had to prove that the polypeptides present in the TIF-IB immunoprecipitate were different from those found in immunoprecipitates derived from a TFIID-containing fraction. For this, fractions containing TIF-IB or TFIID, respectively, were precipitated with the α-TBP antibodies and eluted with the epitope peptide. The eluted proteins were analyzed for transcriptional activity as well as by immunoblotting and silver-staining (Fig. 7). The Western blot was probed both with monoclonal antibodies directed against TBP and with antibodies which recognize the Pol II-specific TAF_{II}-100 (L.Tora, unpublished). As expected, the antibody directed against TAF_{II}-100 labelled a 95–100 kDa protein in the TFIID fraction which was absent in TIF-IB (Fig. 7A). Although in this experiment the TIF-IB-containing fraction contained only half the amount of TBP, TAF_{II}-100 was not detected at higher eluate concentrations or at longer exposures

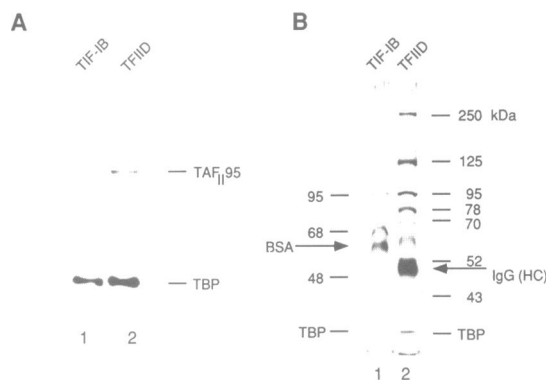

Figure 7. TIF-IB subunits are distinct from TFIID-specific TAFs. **A)** Western blot of immunoprecipitated TIF-IB and TFIID fractions. TIF-IB and TFIID were partially purified by chromatography on DEAE-Sepharose, Heparin-Ultragel and S-Sepharose. TFIID eluted at 300 mM KCl from the S-Sepharose column, whereas TIF-IB eluted at 700 mM KCl. Concentrated fractions were precipitated with purified mAB3G3 coupled to protein A-Sepharose. Lane 1 shows the eluate of an immunoprecipitation carried out with 200 μg of a partially purified TIF-IB fraction. Lane 2 shows the eluate of an immunoprecipitated TFIID fraction. The filter was probed both with the anti-TBP antibody mAB3G3 and with mAB1TA which recognizes the human Pol II-specific TAF_{II}-100. **B)** Polypeptide composition of affinity-purified TIF-IB and TFIID. The same fractions used for the Western blot were electrophoresed on an 8% SDS-polyacrylamide gel and visualized by silver staining. The molecular weights of individual TAFs specific for TIF-IB (lane 1) and TFIID (lane 2) are indicated at both sides (in kDa). The positions of BSA present in the TIF-IB eluate and of the IgG heavy chain (HC) are marked by arrows.

of the autoradiogram. In addition, this fraction did not stimulate Pol II basal transcription indicating that the TIF-IB used for immunoprecipitation was not contaminated with free TBP or Pol II-specific TBP-TAF complexes. A comparison of the immunoeuates on a silver-stained SDS gel revealed TBP and the three murine proteins TAF_I-95, TAF_I-68, and TAF_I-48 in the TIF-IB fraction (Fig. 7B, lane 1), and the characteristic Pol II-specific TAFs with apparent molecular masses of 250, 125, 95, 78, 70, and 52 kDa in the TFIID fraction (Fig. 7B, lane 2). Clearly, the TAFs present in TIF-IB are different in number and size than those in TFIID. The only exception is a 95–100 kDa protein which is found in immunoeuates both from TIF-IB and TFIID. Since, however, the 95 kDa protein present in TIF-IB is not recognized by the TAF_I-100 antibody (Fig. 7A, compare lanes 1 and 2), it very likely represents a different protein. Thus all the Pol I-specific TAFs contained in TIF-IB are different from those found in TFIID.

DISCUSSION

In this communication we report on the purification of TIF-IB, the murine factor that confers promoter selectivity to Pol I. We show that—similar to the analogous human factor SL1—this selectivity factor is a large multimeric protein complex, one of the subunits being TBP. The presence of TBP as an integral part of TIF-IB enabled us to purify this factor to near homogeneity by immunoaffinity techniques using antibodies directed against TBP. Previous attempts to identify the polypeptide composition of TIF-IB failed because of the low cellular abundance of this factor. After five chromatographic columns neither TBP nor any of the TAFs were visible among the different polypeptides (3). This finding corresponds to early results from Tjian's laboratory concerning the purification of SL1 by conventional methods (31). Despite a large gain in the specific activity of SL1 by a series of chromatographic steps, they have been unable to identify the SL1 polypeptide(s) and to carry out a biochemical characterization of this factor due to the lack of sufficient material. In retrospective, the previous failures to purify TIF-IB or SL1 by conventional procedures is not surprising taken into account the low amount of this factor in the cell and the losses during each fractionation step. The recent discovery that SL1 is a complex containing TBP tightly associated with three distinct polypeptides (9), together with the ability to track TBP by antibodies, facilitated the purification of this Pol I promoter-selective transcription factor. However, although the method of immunoaffinity chromatography reduces the number of chromatographic steps and thus increases the yield of TIF-IB, the biochemical characterization and the cloning of the individual subunits will be a formidable task considering the large amounts of cells required to yield sufficient amounts of TIF-IB. According to our estimation, the total amount of TBP complexes involved in Pol I transcription is at least one order of magnitude lower than the TBP-TAF complexes required for Pol II and Pol III gene transcription. Note that we have obtained approximately 200 ng of native TIF-IB from about 5×10^{11} ascites cells. Assuming a final yield of 10% of TIF-IB, this amount corresponds to about 500 molecules of TIF-IB per cell, a number which corresponds to the number of ribosomal transcription units per diploid cell. Therefore, the cloning of the murine Pol I-specific TAFs will require about 10^{13} cells. Another drawback in the purification is the need to completely separate TIF-IB from TFIID which in mouse appears to be more difficult to achieve than in humans.

The recent findings that one general factor, the TATA box binding protein, is required for transcription by all three classes of RNA polymerases and that specific arrays of associated polypeptides (TAFs) direct promoter specificity of a given class of RNA polymerase underscores the importance of TAFs in determining promoter specificity by different RNA polymerases. Apparently TIF-IB/SL1 is functionally analogous to TFIID and TFIIB, the TBP-containing factors which nucleate transcription complex formation on Pol II and III promoters (for review, see 15, 32). Thus TBP is a common component of transcription complexes for all three classes of polymerases and the basic mechanisms of initiation complex assembly appear to be strongly conserved. This finding suggests that TBP is a primordial eukaryotic transcription factor that evolved to function with distinct gene promoters.

The TAFs, on the other hand, appear to play an important role in selecting the appropriate RNA polymerase. Although some of the Pol II-specific TAFs have been cloned, and their properties have been analyzed (33–37), the function of most TFIID subunits is unknown. The presence of multiple subunits indicates that there is an intrinsic assembly process where one or more of the TAFs interact directly with TBP, and subsequently recruit the RNA polymerase-specific TAFs via protein-protein interactions into TBP-containing multiprotein complexes specific for a given class of genes. The role of TBP in rDNA promoter recognition is unknown. It may be involved in DNA binding or in the interaction with some other compound of the transcription apparatus. In fact, TBP appears to be capable of specifically recognizing sequences that are quite dissimilar to a conventional TATA box (38) and evidence has also been presented that TBP can be anchored to TATA-less promoters by means of protein-protein interactions with an undefined tethering activity (39, 40). Probably both possibilities are realized at the rDNA promoter. Binding-competition studies have demonstrated that TBP has a low but significant affinity to the core region of the murine rDNA promoter (J. Heix, unpublished results). The binding affinity compares to that of the SV40 major late promoter, i.e. ca. 10% of consensus TATA boxes. It has been concluded that many, if not all, TATA-less promoters differ from TATA-containing promoters simply in the affinity of their –30 regions for binding of TFIID, with functional binding supported in part by other nearby promoter elements (41). Quite likely, the association of TBP with different combinations of TAFs modifies both its binding specificity and its ability to communicate with different transcription activators and thus determines promoter specificity.

The composition of TAFs in various TBP complexes involved in transcription by the three classes of RNA polymerases is very different, and no common subunit appears to be shared by the polymerase-specific TBP complexes. This structural complexity reflects the different functions and the diversity of transcriptional regulation exhibited by SL1/TIF-IB, TFIID and TFIIB, respectively. The relatively more simple TAF composition of Pol I- and Pol III-specific TBP complexes may reflect (a) more restricted role(s) in interactions with promoter-specific regulators, RNA polymerases and their accessory factors. On the other hand, the more elaborate assembly of TFIID as compared to SL1/TIF-IB and TFIIB may reflect the diversity of genes transcribed by Pol II as well as the fact that thousands of mRNA coding genes have to be expressed in a temporally regulated and spatially restricted manner. Indeed, a large number of polypeptides that interact with TBP have been described (42–46). To accommodate all these interactions, the assortment of proteins

that exist in complex with TBP *in vivo* must constantly be in flux.

Considering that the only function of Pol I is to transcribe ribosomal RNA genes, it is surprising that TIF-IB/SL1 is a large multimeric protein containing TBP and several polypeptides. These Pol I-specific TAFs are different from TAFs present in Pol II- or Pol III-specific TBP complexes and apparently serve distinct functions. We envision that the Pol I-specific TAFs most likely interact with the upstream binding factor UBF and with RNA polymerase I. Moreover, one or more of the TAFs very likely contact the species-specific element of the rDNA promoter. In this context it should be recalled that a characteristic feature of rRNA transcription by Pol I is species specificity. Earlier work has established that the TIF-IB/SL1 fraction is responsible for this phenomenon. SL1 was required to transcribe the human rDNA template, whereas the murine factor TIF-IB was required to transcribe mouse rDNA (19, 20). Interestingly, the murine Pol I-specific TAFs identified in this study are similar but not identical to those of SL1 (9). The most obvious difference resides in the largest polypeptide which has a molecular mass of 110 kDa in SL1 and 95 kDa in TIF-IB. This finding suggests that this subunit may play an important role in species-specific promoter recognition. However, the final elucidation of the molecular mechanisms that govern specific transcription of Pol I genes, will require the purification, cloning as well as structural and functional comparison of the individual TAFs in the TIF-IB and SL1 complex.

ACKNOWLEDGEMENTS

We thank Bettina Erny for help in cell culture and extract preparation. We are grateful to Henk Stunnenberg and Udo Rudloff for help and stimulating discussions. We would also like to thank Yves Lutz for monoclonal antibodies (3G3, 1TA) and Adrien Straub for microsequencing TAF_{II}-100. This work was supported by the Deutsche Forschungsgemeinschaft (Leibniz-Programm and SFB 229), the Fonds der Chemischen Industrie and by a grant of the Science Program of the Commission of the European community (SCI*-0259-C).

REFERENCES

- Sawadogo, M. and Sentenac, A. (1990). *Annu. Rev. Biochem.* **59**, 711–754.
- Schnapp, A. and Grummt, I. (1991). *J. Biol. Chem.* **266**, 24588–24595.
- Schnapp, A., Hédelt, W., Clos, J., Schreck, R., Cvekl, A., and Grummt, I. (1990a). *Nucl. Acids Res.* **18**, 1385–1393.
- Bell, S. P., Learned, R. M., Jantzen, H.-M., and Tjian, R. (1988). *Science* **241**, 1192–1197.
- Sentenac, A. (1985). *CRC Crit. Rev. Biochem.* **18**, 31–90.
- Lobo, S., Lister, J., Sullivan, M. L., and Hernandez, N. (1991). *Genes&Dev.* **5**, 1477–1489.
- Margottin, F., Dujardin, G., Gerard, M., Egly, J.-M., Huet, J., and Sentenac, A. (1991). *Nature* **251**, 424–426.
- Simmen, K., Bernues, J., Parry, H. D., Stunnenberg, H. G., Berkenstamm, A., Cavallini, B., Egly, J.-M., and Mattaj, I. (1991). *EMBO J.* **10**, 1853–1862.
- Comai, L., Tanese, N., and Tjian, R. (1992). *Cell* **68**, 965–976.
- Schultz, C. M., Reeder, R. H., and Hahn, S. (1992). *Cell* **69**, 697–702.
- White, R. J., Jackson, S. P., and Rigby, P. W. J. (1992). *Proc. Natl. Acad. Sci. USA* **89**, 1949–1953.
- Cormack, B. R. and Struhl, K. (1992). *Cell* **69**, 685–696.
- Brou, C., Wu, J., Ali, S., Scheer, E., Lang, C., Davidson, I., Chambon, P., and Tora, L. (1993a). *Nucl. Acids Res.* **21**, 5–12.
- Brou, C., Chaudhary, S., Davidson, I., Lutz, Y., Wu, J., Egly, J.-M., Tora, L., and Chambon, P. (1993b). *EMBO J.* **12**, 489–499.
- Rigby, P. W. J. (1993). *Cell* **72**, 7–10.
- Grummt, I., Roth, E., and Paule, M. (1982). *Nature* **296**, 173–174.
- Mishima, Y., Financsek, I., Kominami, R., and Muramatsu, M. (1982). *Nucl. Acids Res.* **10**, 6659–6670.
- Miesfeld, R. and Arnheim, N. (1984). *Mol. Cell. Biol.* **4**, 221–227.
- Bell, S. P., Pikaard, C. S., Reeder, R. H., and Tjian, R. (1989). *Cell* **59**, 489–497.
- Bell, S. P., Jantzen, H.-M., and Tjian, R. (1990). *Genes&Dev.* **4**, 943–954.
- Clos, J., Buttgerit, D., and Grummt, I. (1986). *Proc. Natl. Acad. Sci. USA* **83**, 604–608.
- Schnapp, A., Pfeleiderer, C., Rosenbauer, H., and Grummt, I. (1990b). *EMBO J.* **9**, 2857–2863.
- Harlow, E. and Lane, D. (1988). Cold Spring Harbor Lab., Cold Spring Harbor, NY.
- Tamura, T., Sumita, K., Fujino, I., Aoyama, A., Horikoshi, M., Hoffmann, A., Roeder, R. G., Muramatsu, M., and Mikoshiba, K. (1991). *Nucl. Acids Res.* **19**, 3861–3865.
- Nakajima, N., Horikoshi, M., and Roeder, R. G. (1988). *Mol. Cell. Biol.* **8**, 4028–4040.
- Peterson, M. G., Tanese, N., Pugh, B. F., and Tjian, R. (1990). *Science* **245**, 1625–1630.
- Kelleher, R. J., Flanagan, P. M., and Kornberg, R. D. (1990). *Cell* **61**, 1209–1215.
- Martin, K. J., Lilie, J. W., and Green, M. R. (1990). *Nature* **346**, 147–152.
- Tanese, N., Pugh, B. F., and Tjian, R. (1991). *Genes&Dev.* **5**, 2212–2224.
- Zhou, Q., Liebermann, P. M., Boyer, T. G., and Berk, A. J. (1992). *Genes&Dev.* **6**, 1964–1974.
- Learned, R. M., Cordes, S., and Tjian, R. (1985). *Mol. Cell. Biol.* **5**, 1358–1369.
- Pugh, B. F. and Tjian, R. (1992). *J. Biol. Chem.* **267**, 679–682.
- Hoey, T., Weinzierl, R. O. J., Gill, G., Chen, J. L., Dynlacht, B. D., and Tjian, R. (1993). *Cell* **72**, 247–260.
- Weinzierl, R. O. J., Dynlacht, B. D., and Tjian, R. (1993). *Nature* **362**, 511–517.
- Ruppert, S., Wang, E., and Tjian, R. (1993). *Nature* **362**, 175–179.
- Hisatake, K., Hasegawa, S., Takada, R., Nakatani, Y., Horikoshi, M., and Roeder, R. G. (1993). *Nature* **362**, 179–181.
- Dynlacht, B. D., Weinzierl, R. O. J., Admon, A., and Tjian, R. (1993). *Nature* **363**, 176–179.
- Singer, V. L., Wobbe, C. R., and Struhl, K. (1990). *Genes&Dev.* **4**, 636–645.
- Pugh, B. F. and Tjian, R. (1990). *Cell* **61**, 1187–1197.
- Pugh, B. F. and Tjian, R. (1991). *Genes&Dev.* **5**, 1935–1945.
- Wiley, S. R., Kraus, R. J., and Mertz, J. E. (1992). *Proc. Natl. Acad. Sci. USA* **89**, 5814–5818.
- Stringer, K. F., Ingles, C. J., and Greenblatt, I. (1990). *Nature* **345**, 783–786.
- Lee, W. S., Kao, C. C., Bryant, G. O., Liu, X., and Berk, A. J. (1991). *Cell* **67**, 365–376.
- Liebermann, P. M. and Berk, A. J. (1991). *Genes&Dev.* **5**, 2441–2454.
- Meisterernst, M. and Roeder, R. G. (1991). *Cell* **67**, 557–567.
- Inostroza, J. A., Mermelstein, F. H., Ha, I., Lane, W. S., and Reinberg, D. (1992). *Cell* **70**, 477–489.