

A

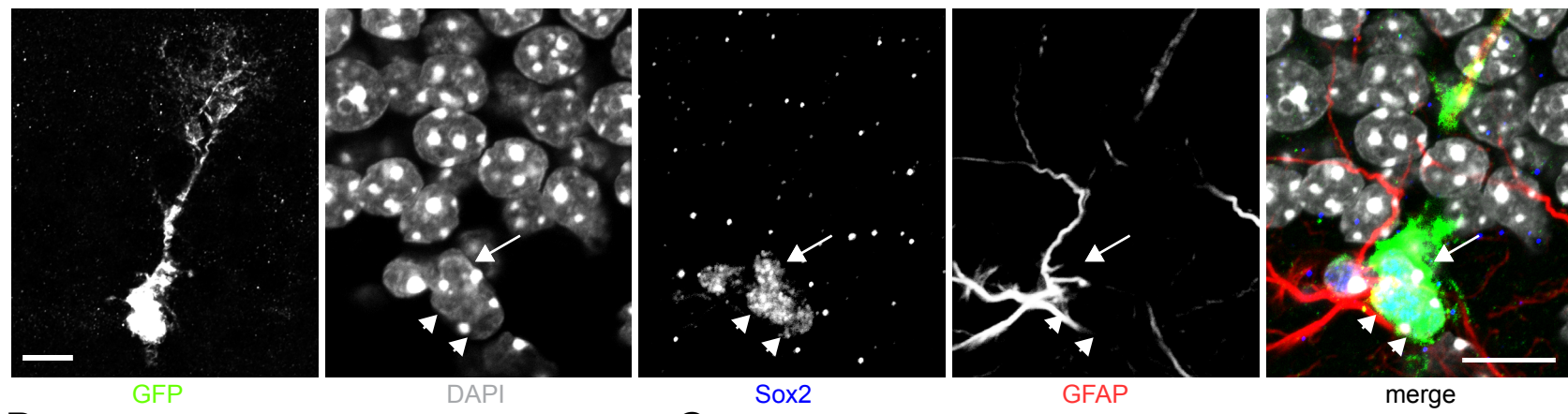

B

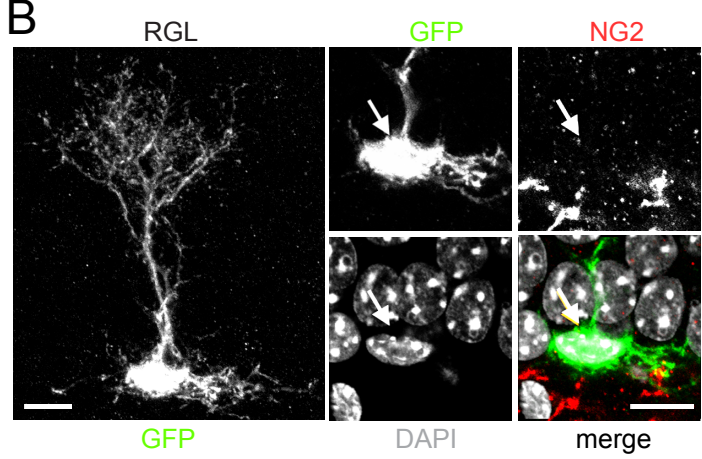

C

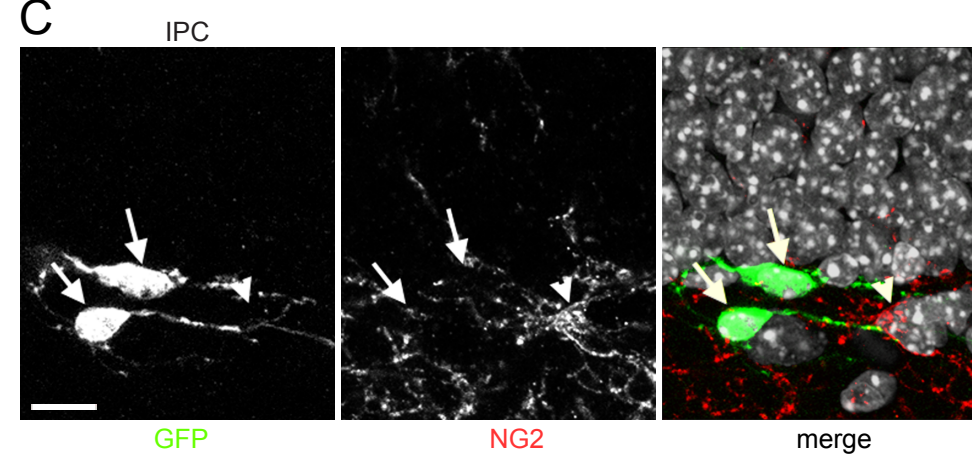

D

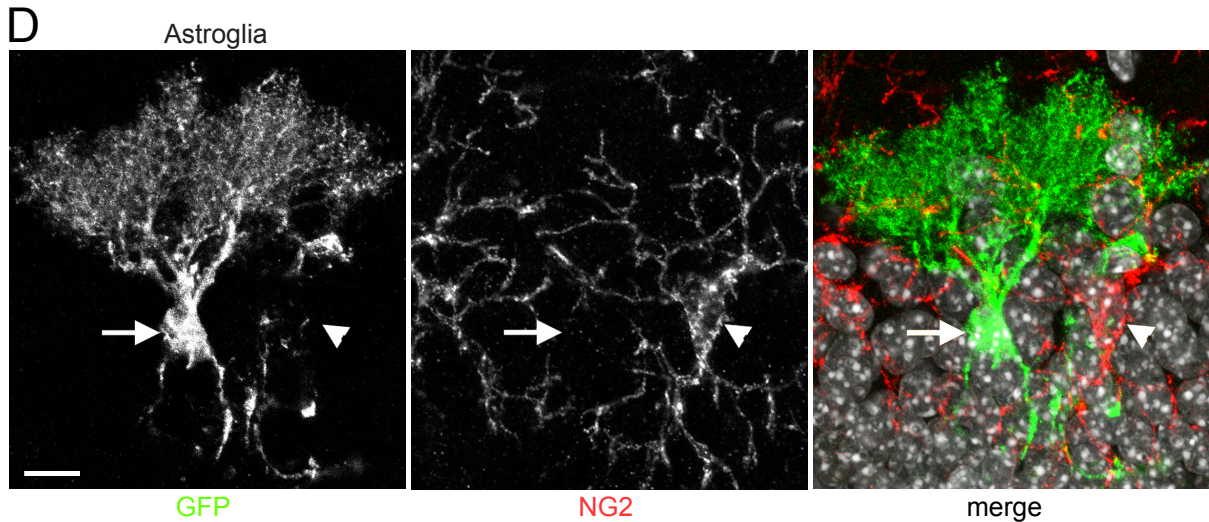

E

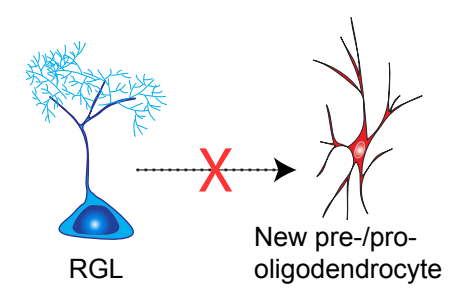

A

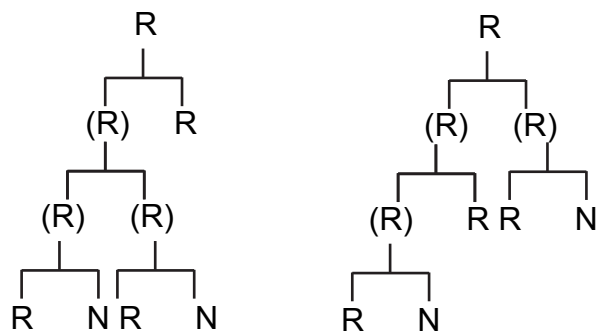

B

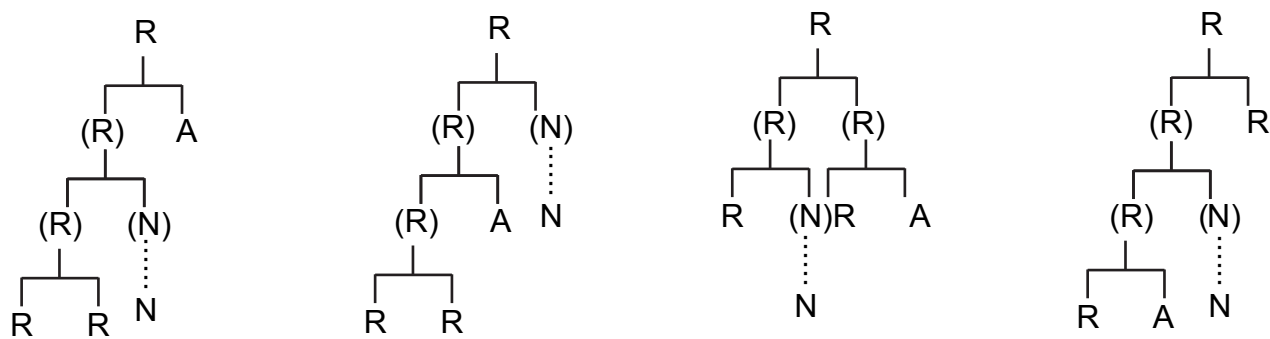

A

Clone classification	Cell number per clone (1 mpi)								
	1	2	3	4	5	6	14	17	20
Quiescent (single R)	14								
Expansion (R + R)		2							
Unipotent (R + A)		6	4		1				
Unipotent (R + N)		6	3		2	2		1	
Multipotent (R + A + N)					2		1		1
Differentiated (no R)	1	3	4		1				

B

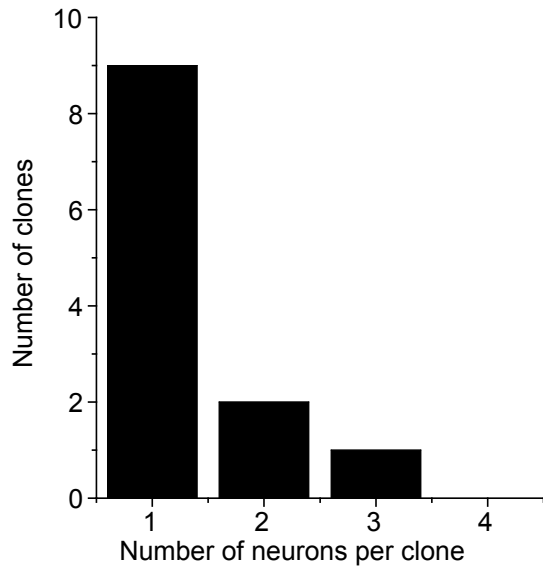

C

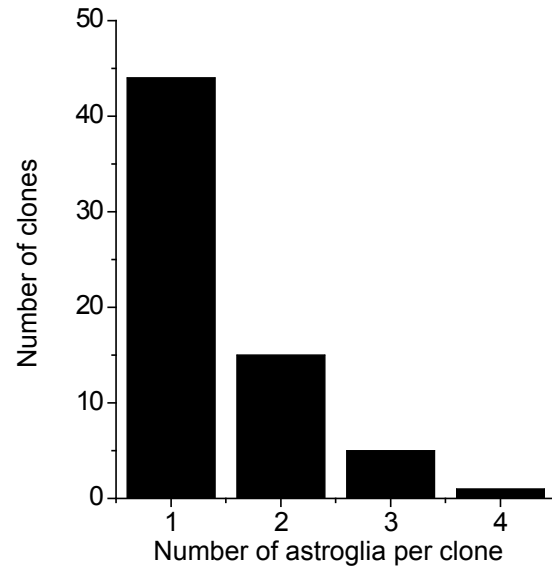

D

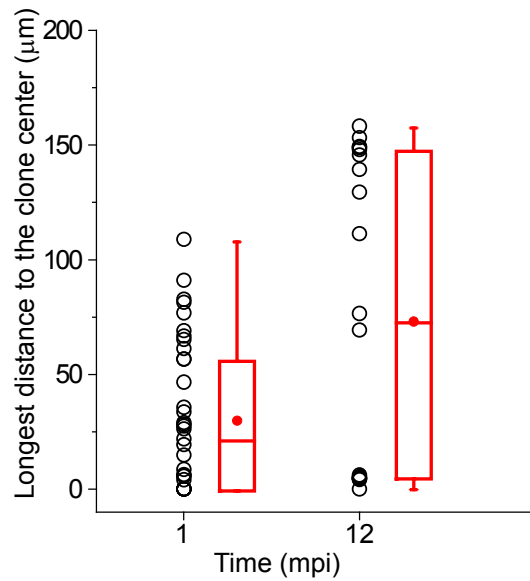

E

