

Tc00.1047053510889.310

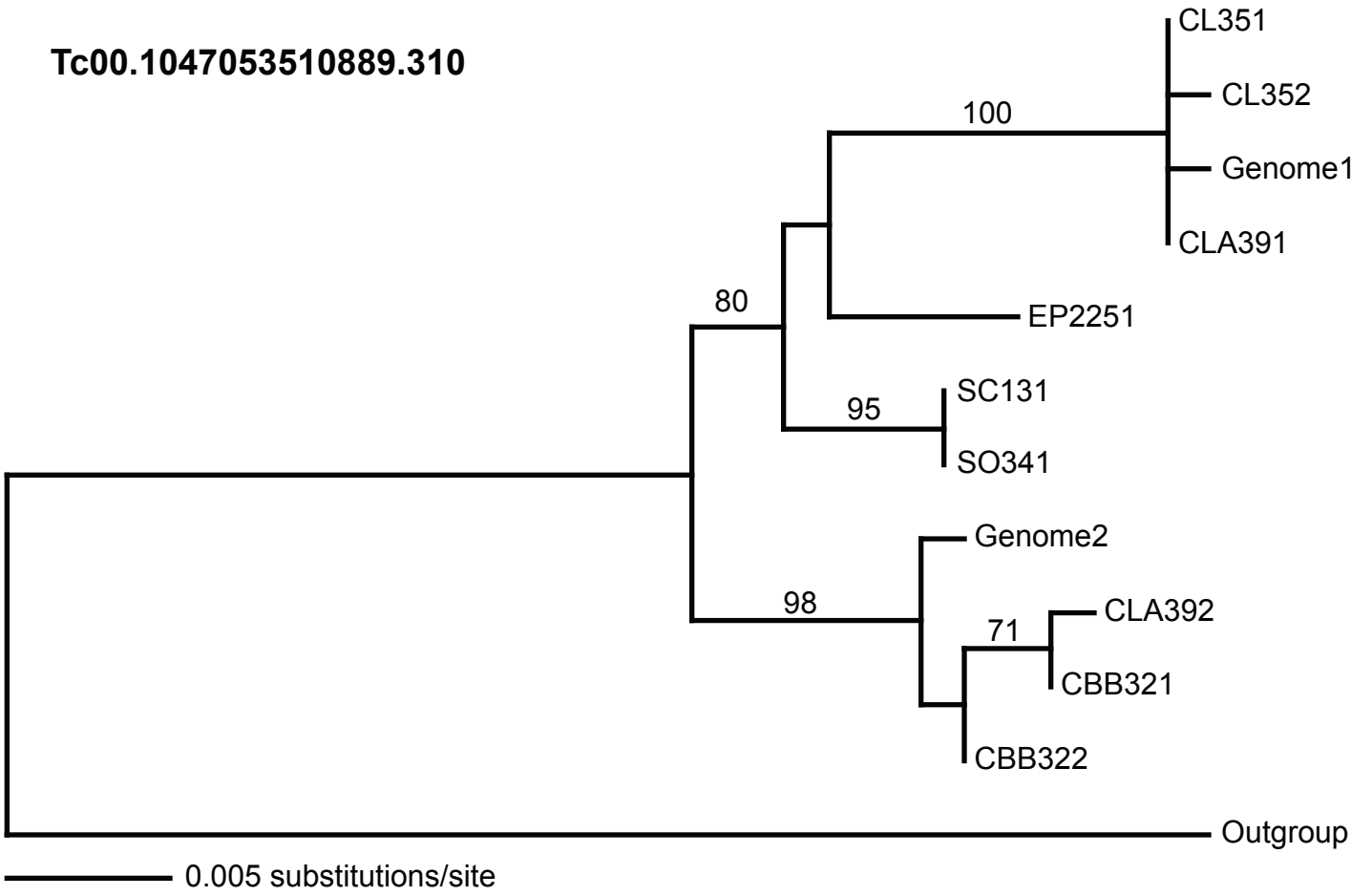

Tc00.1047053509561.20

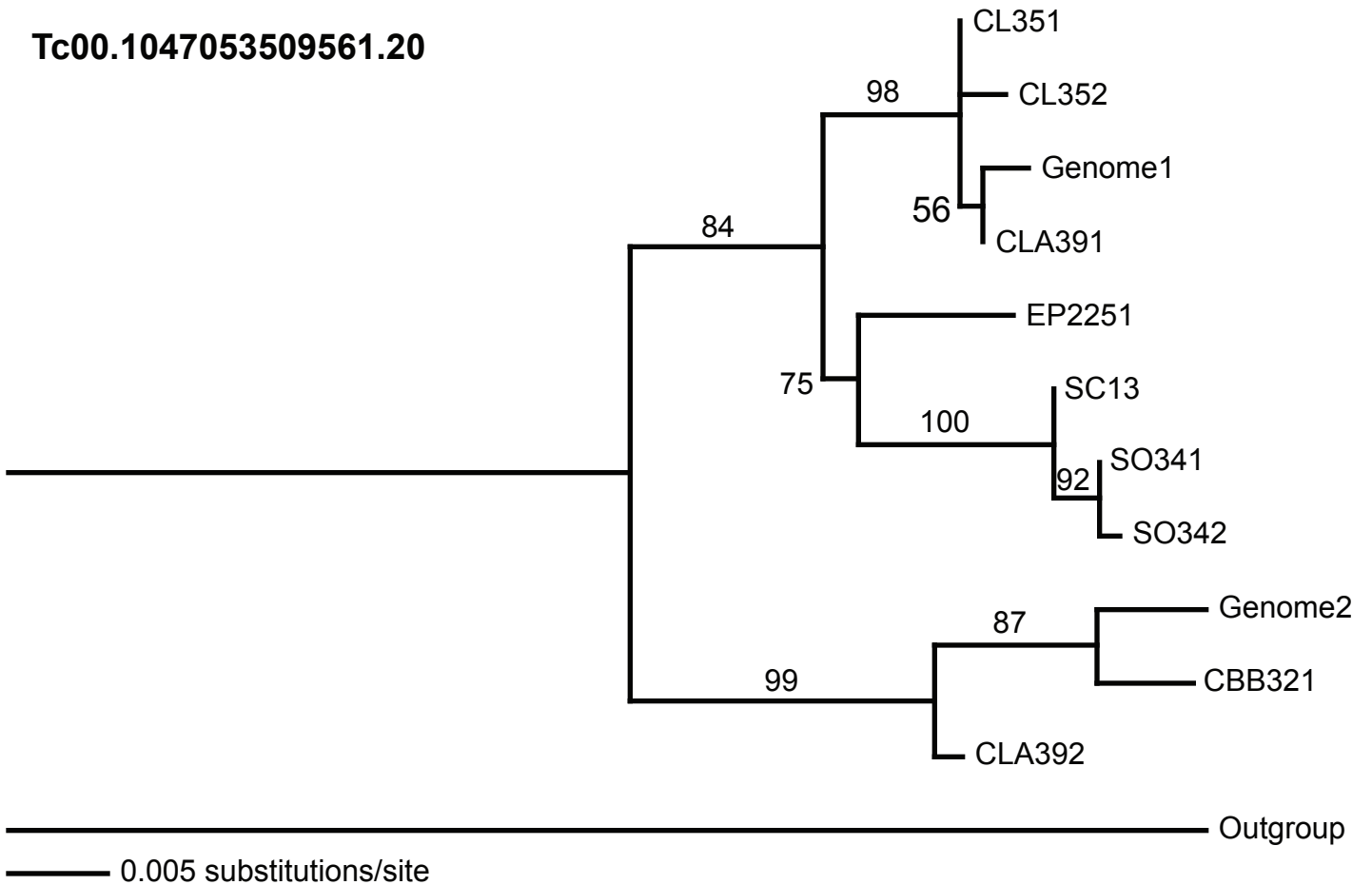

Tc00.1047053508719.70

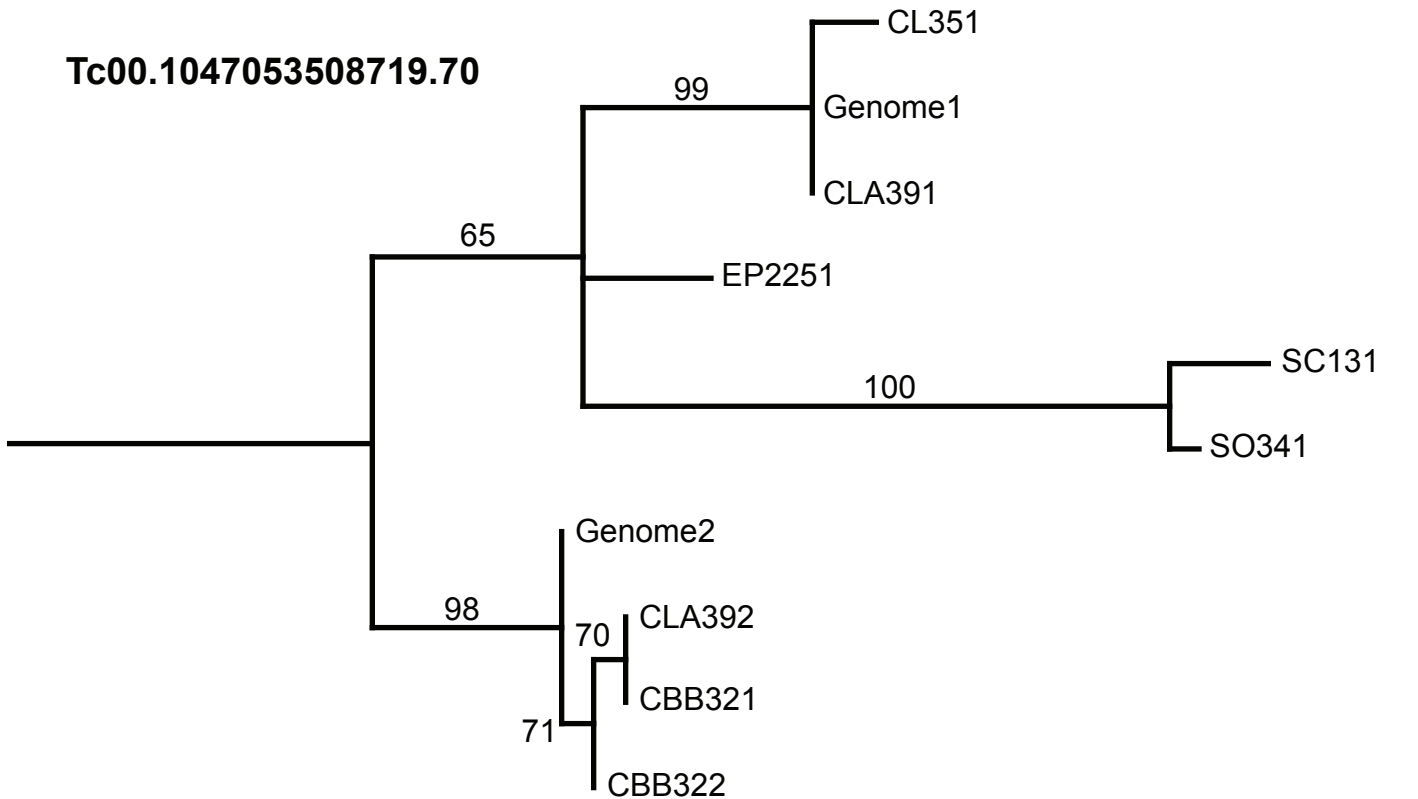

Outgroup

0.005 substitutions/site

Tc00.1047053508461.80

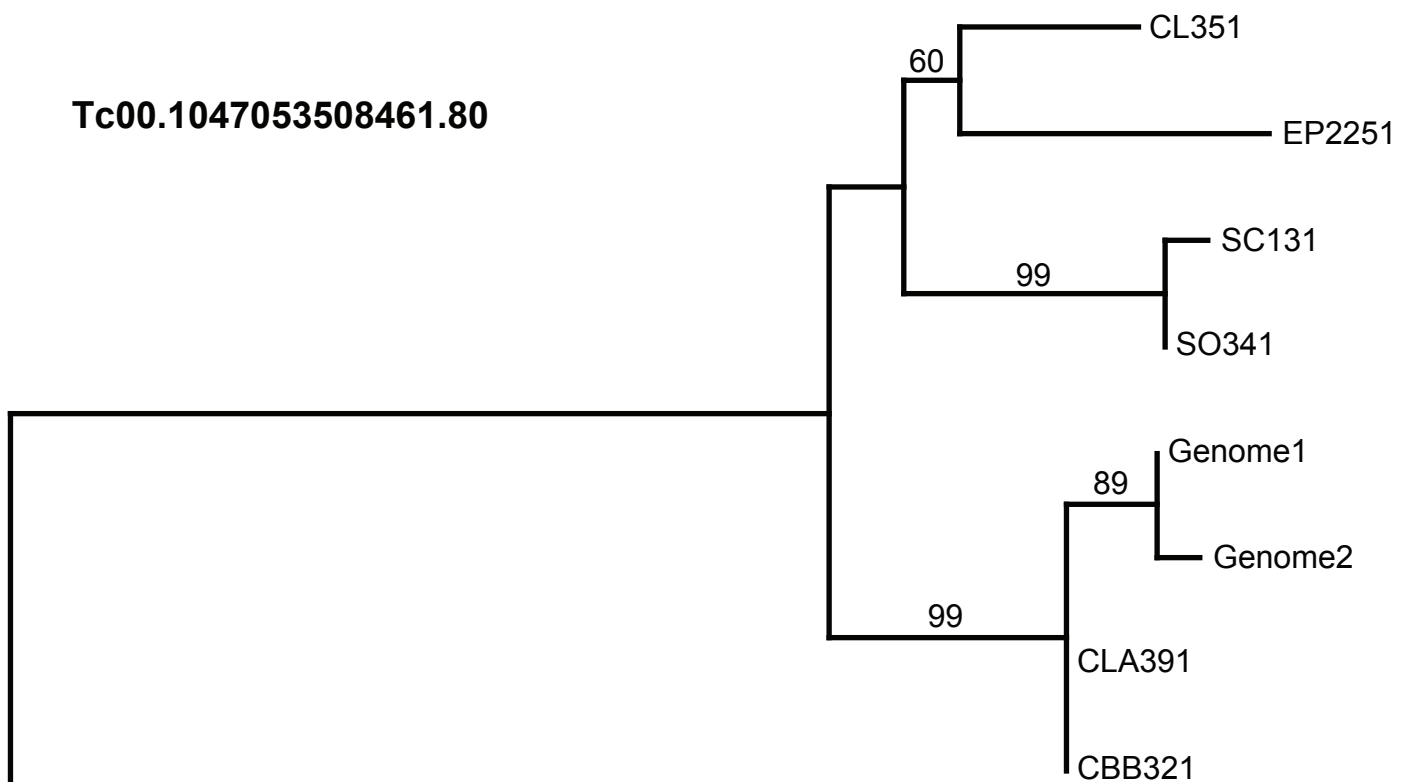

Outgroup

0.005 substitutions/site

Tc00.1047053506529.310

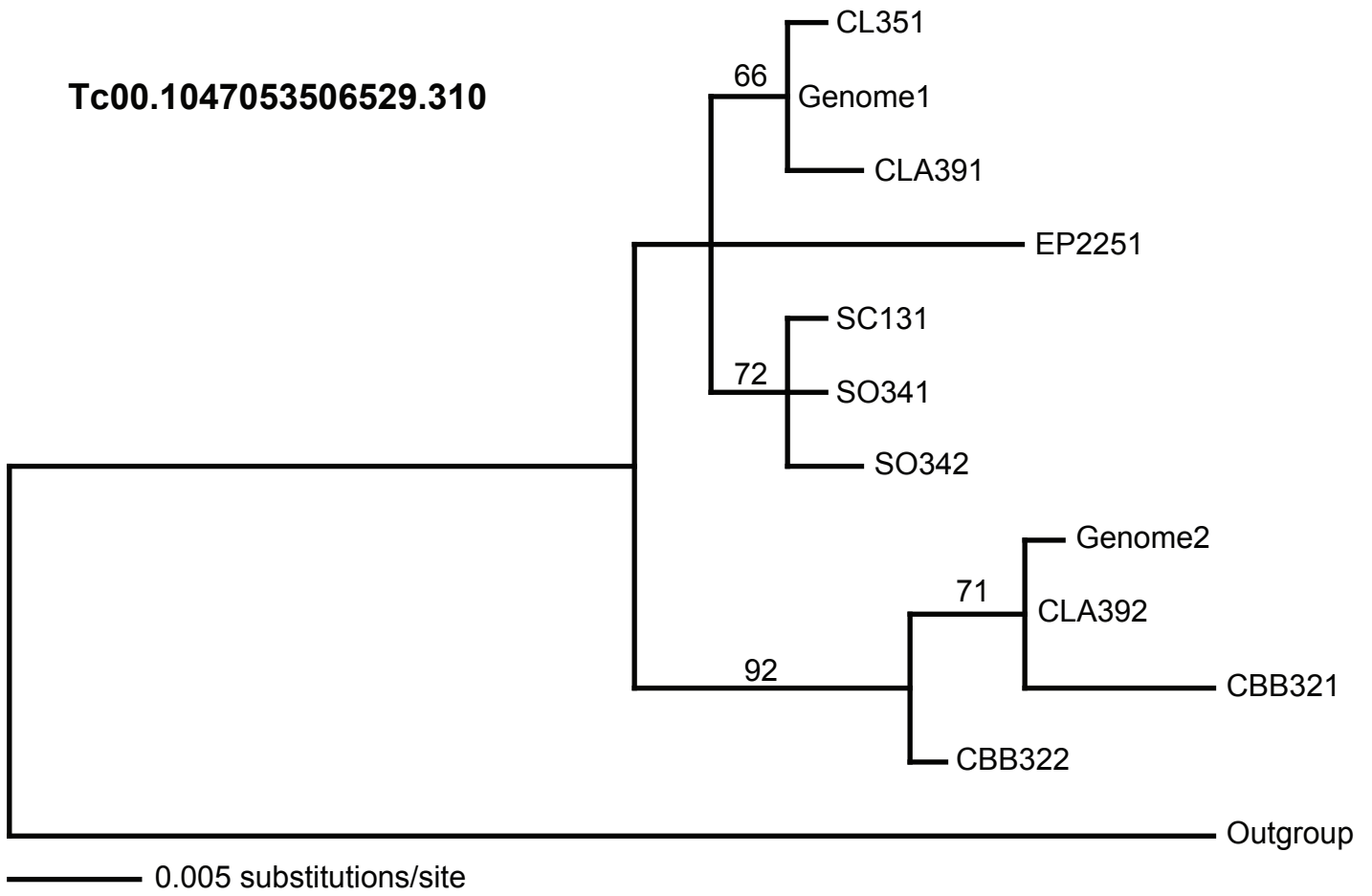

Tc00.1047053504059.20

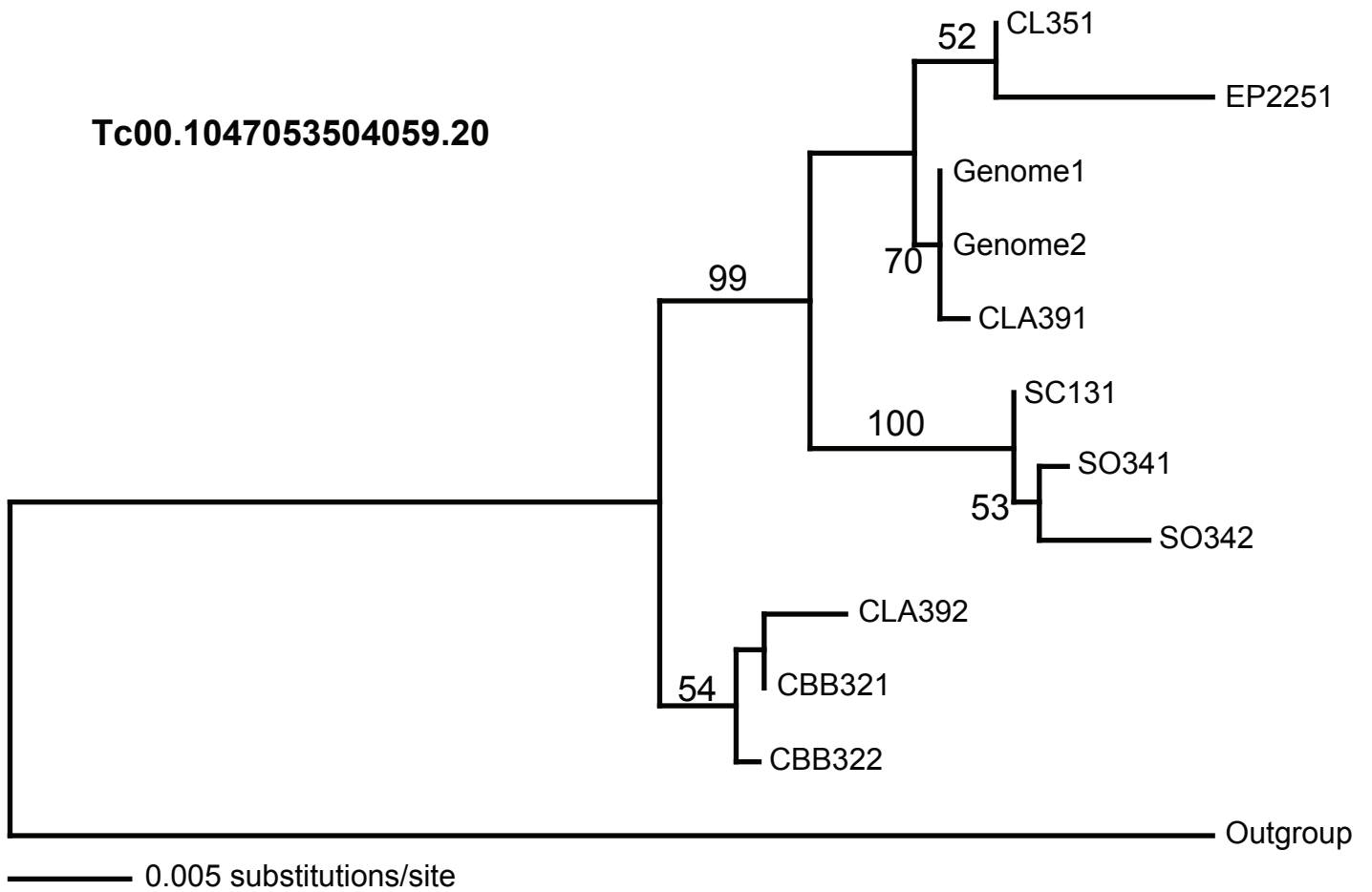

Tc00.1047053504013.40

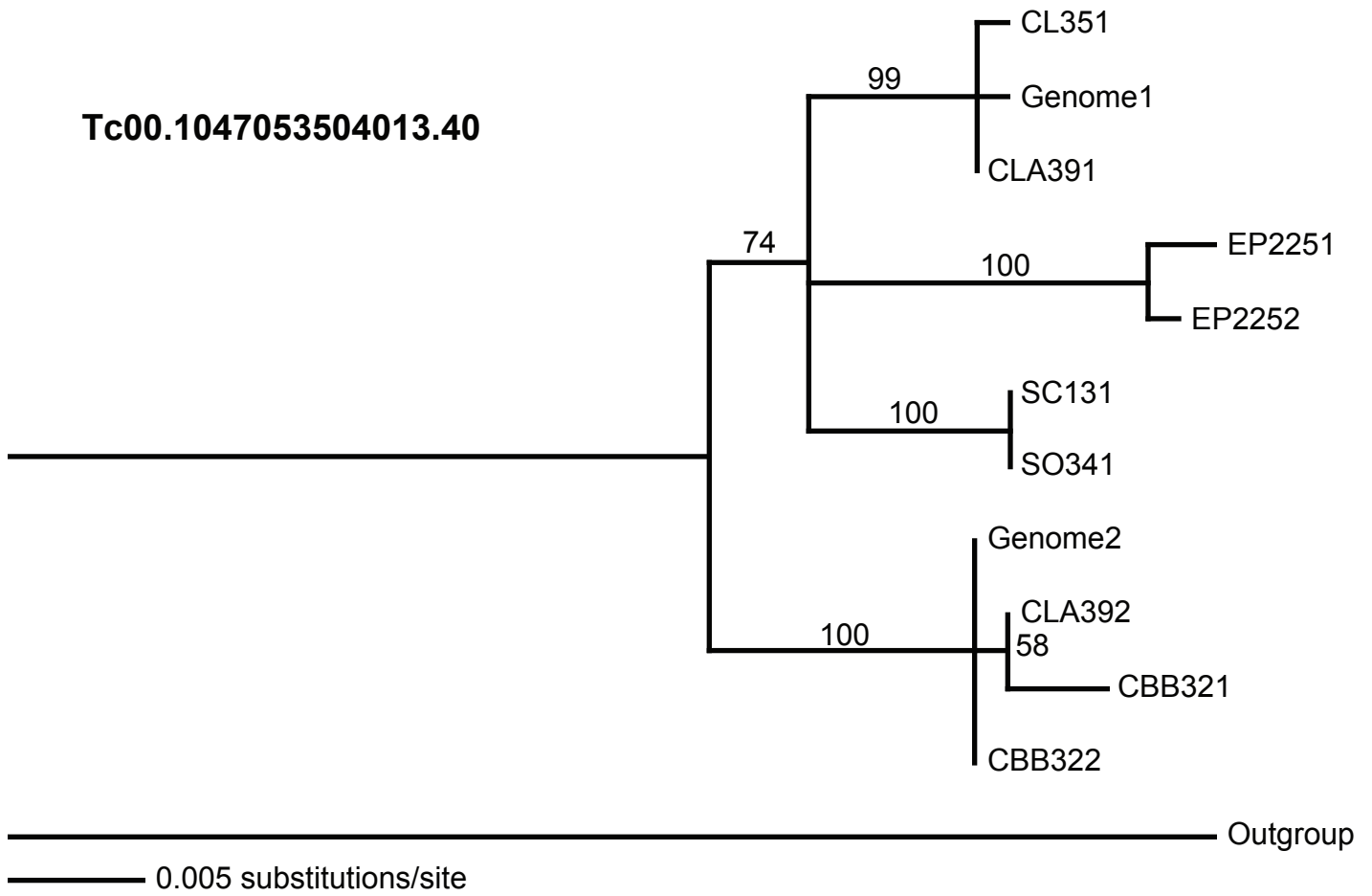

Tc00.1047053503909.76

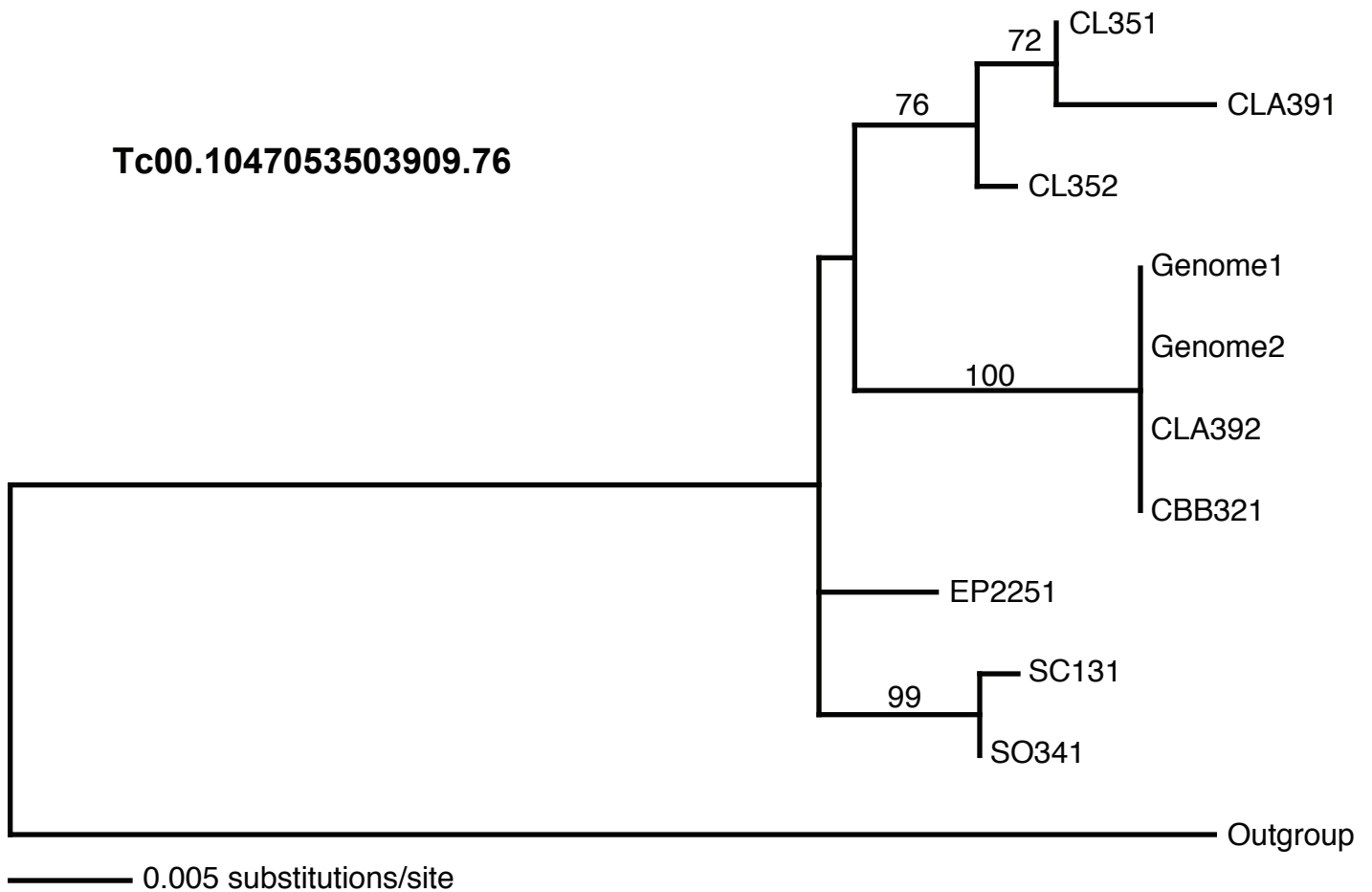

Tc00.1047053510889.210

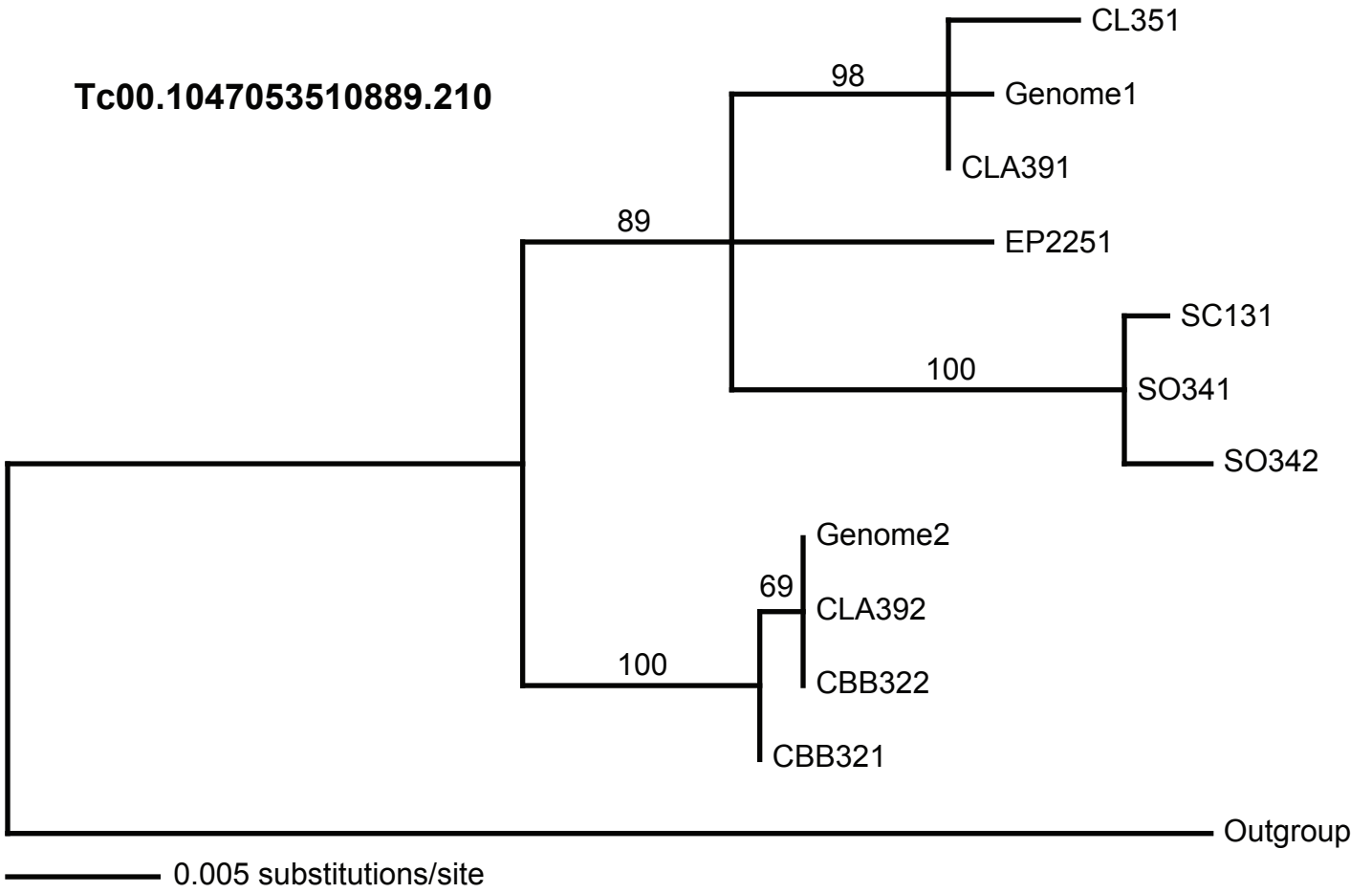

Tc00.1047053507801.70

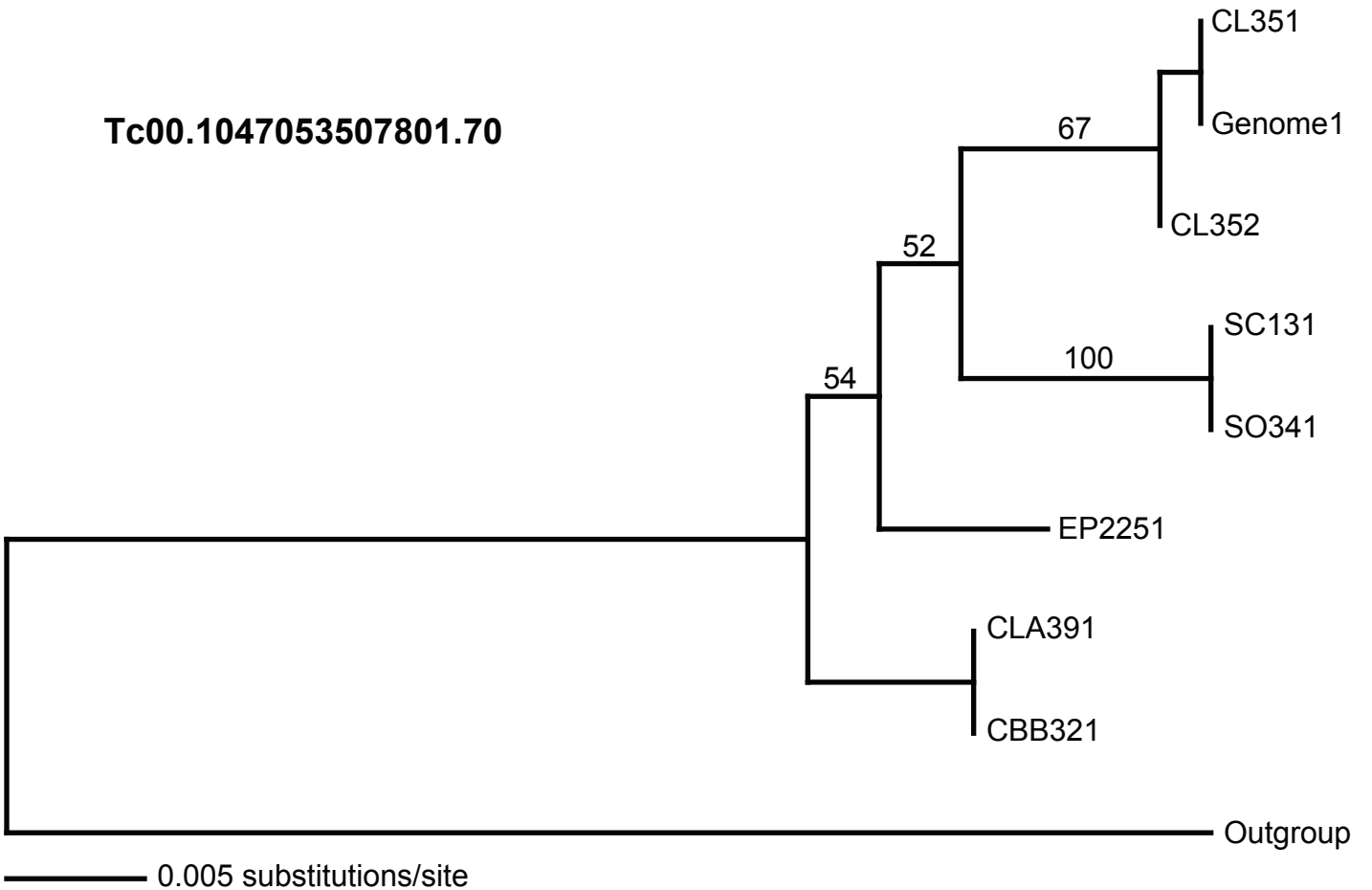

Tc00.1047053510123.24

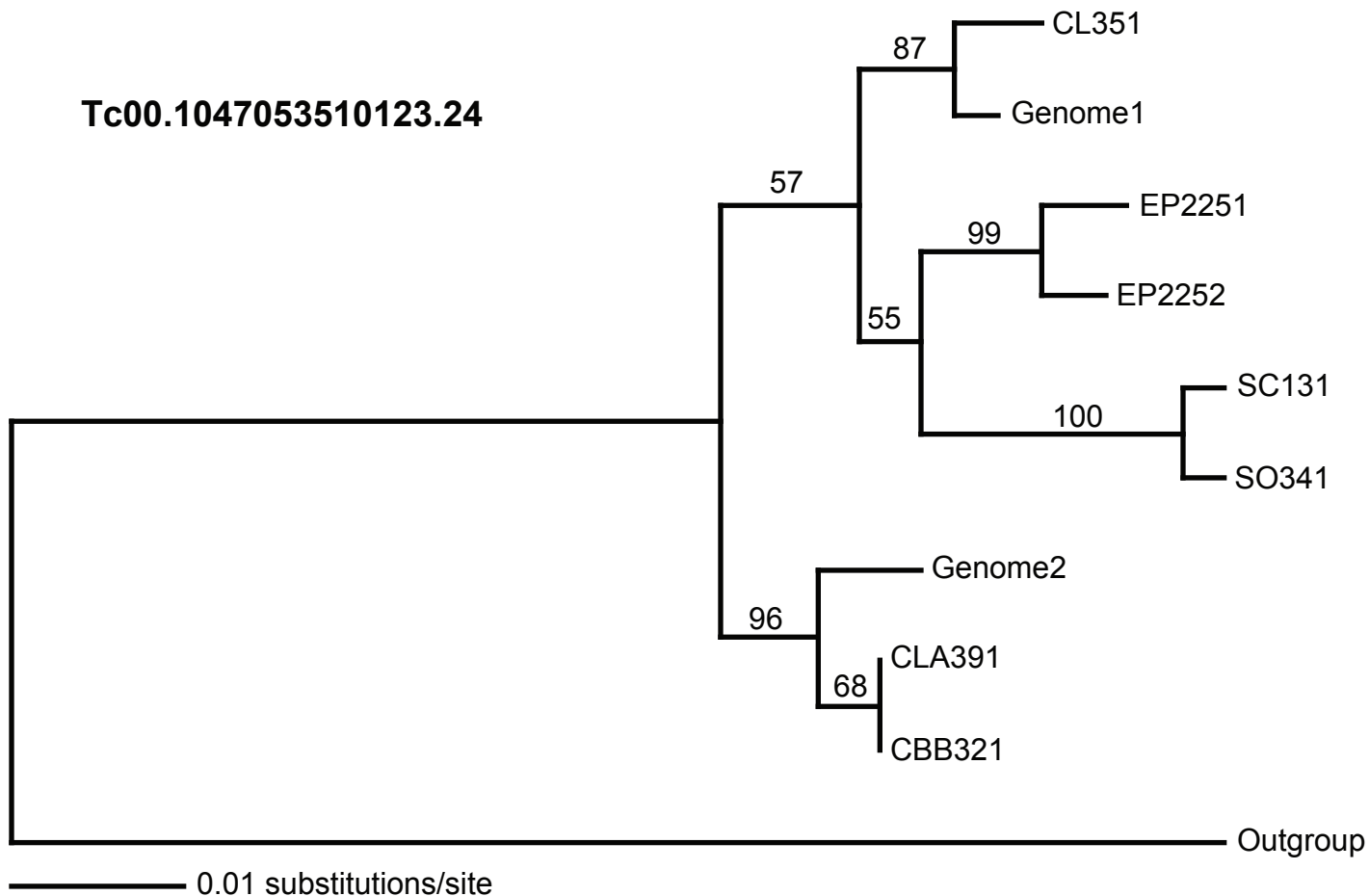

Tc00.1047053511529.200

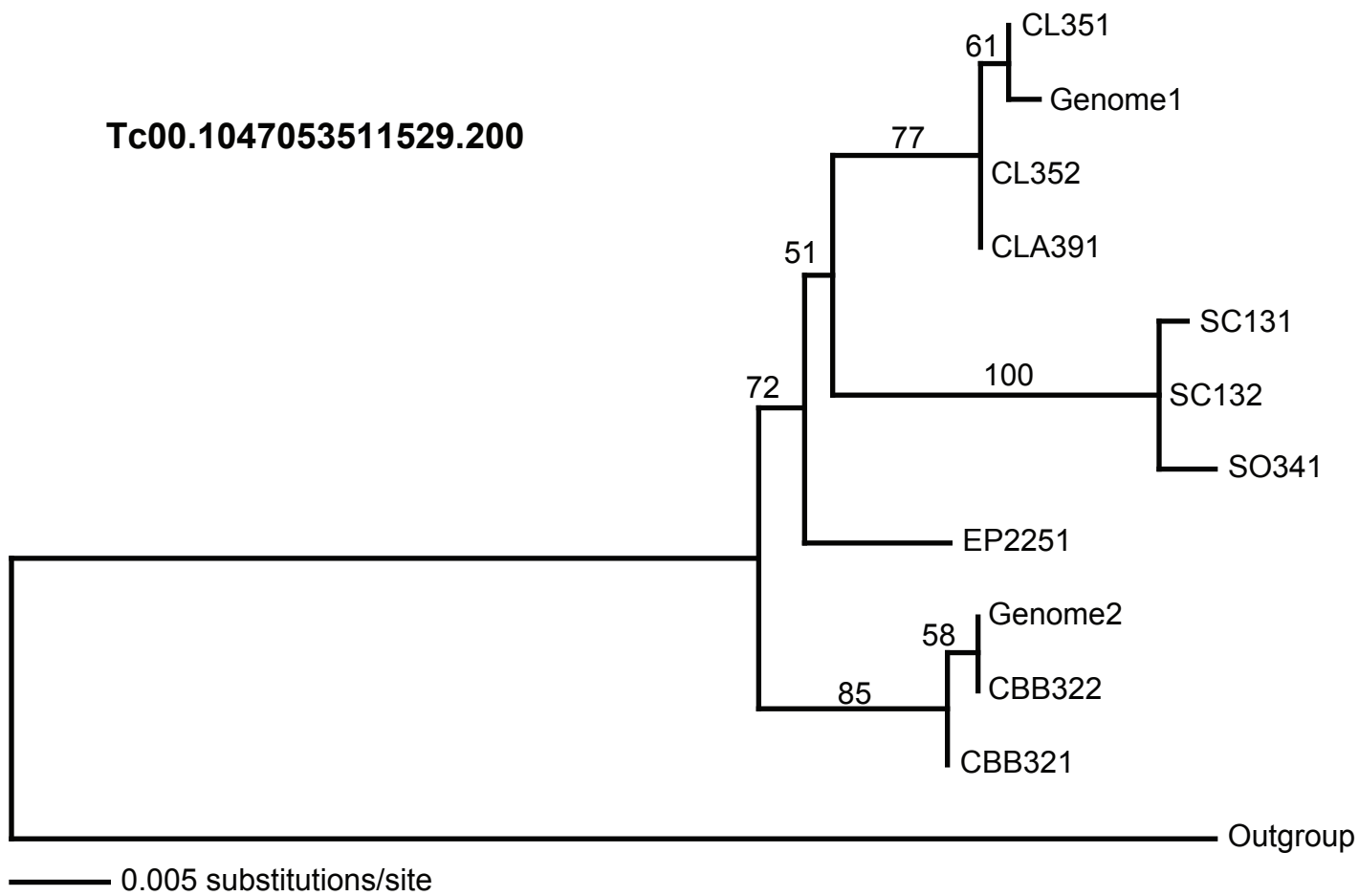

Tc00.1047053511153.124

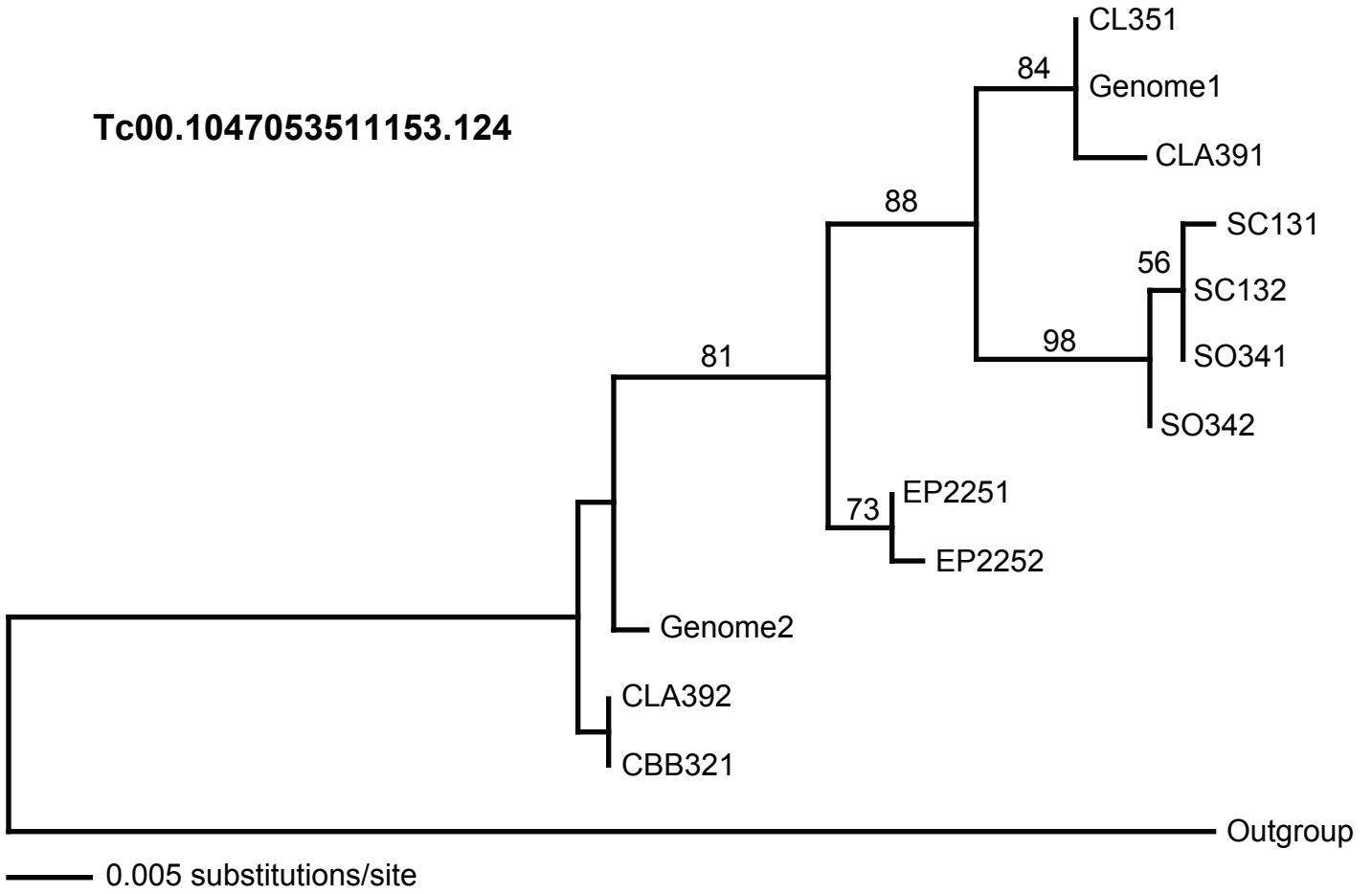

Tc00.1047053510131.90

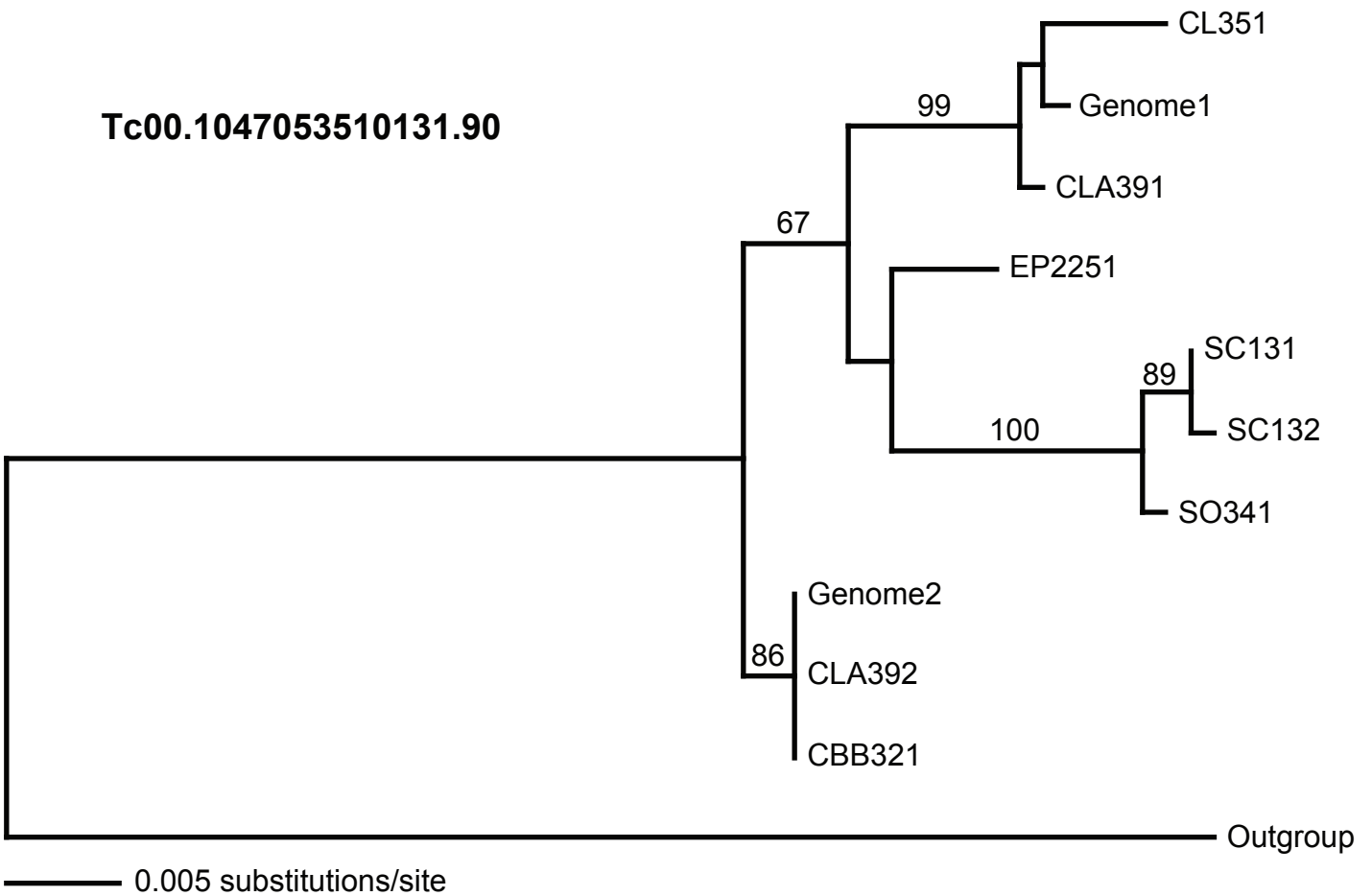

Tc00.1047053508153.540

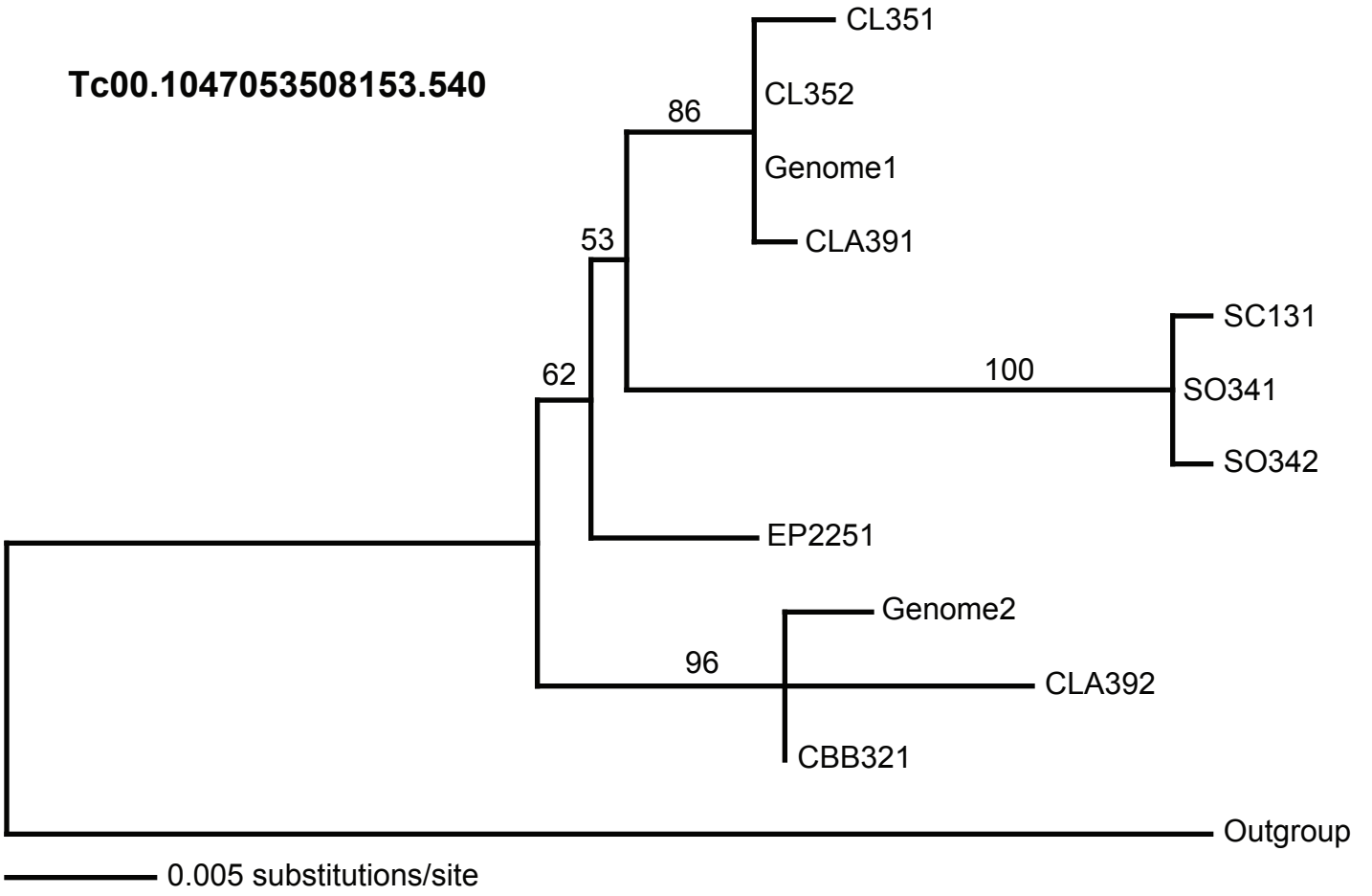

Tc00.1047053503865.40

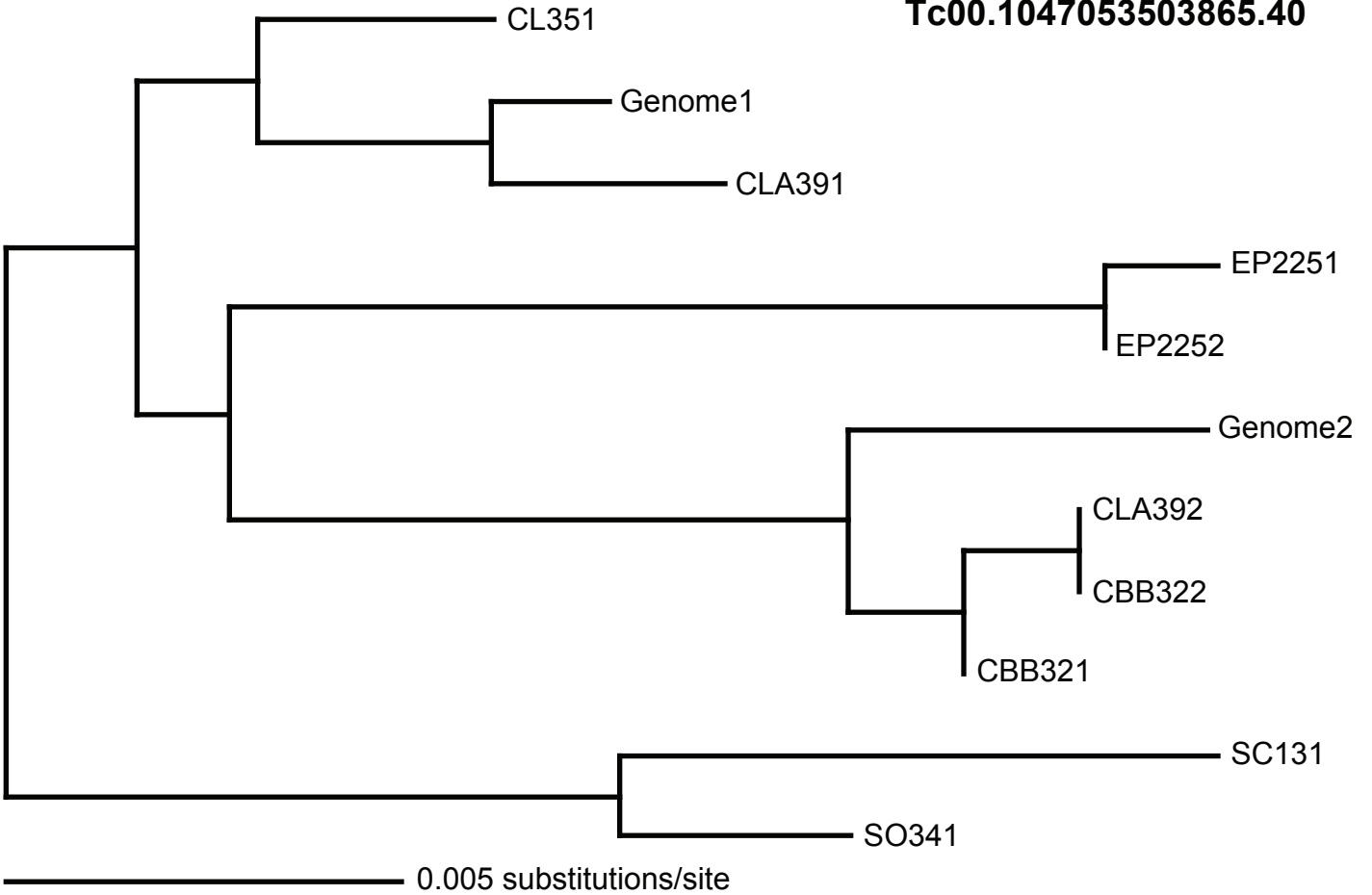

Tc00.1047053510765.50

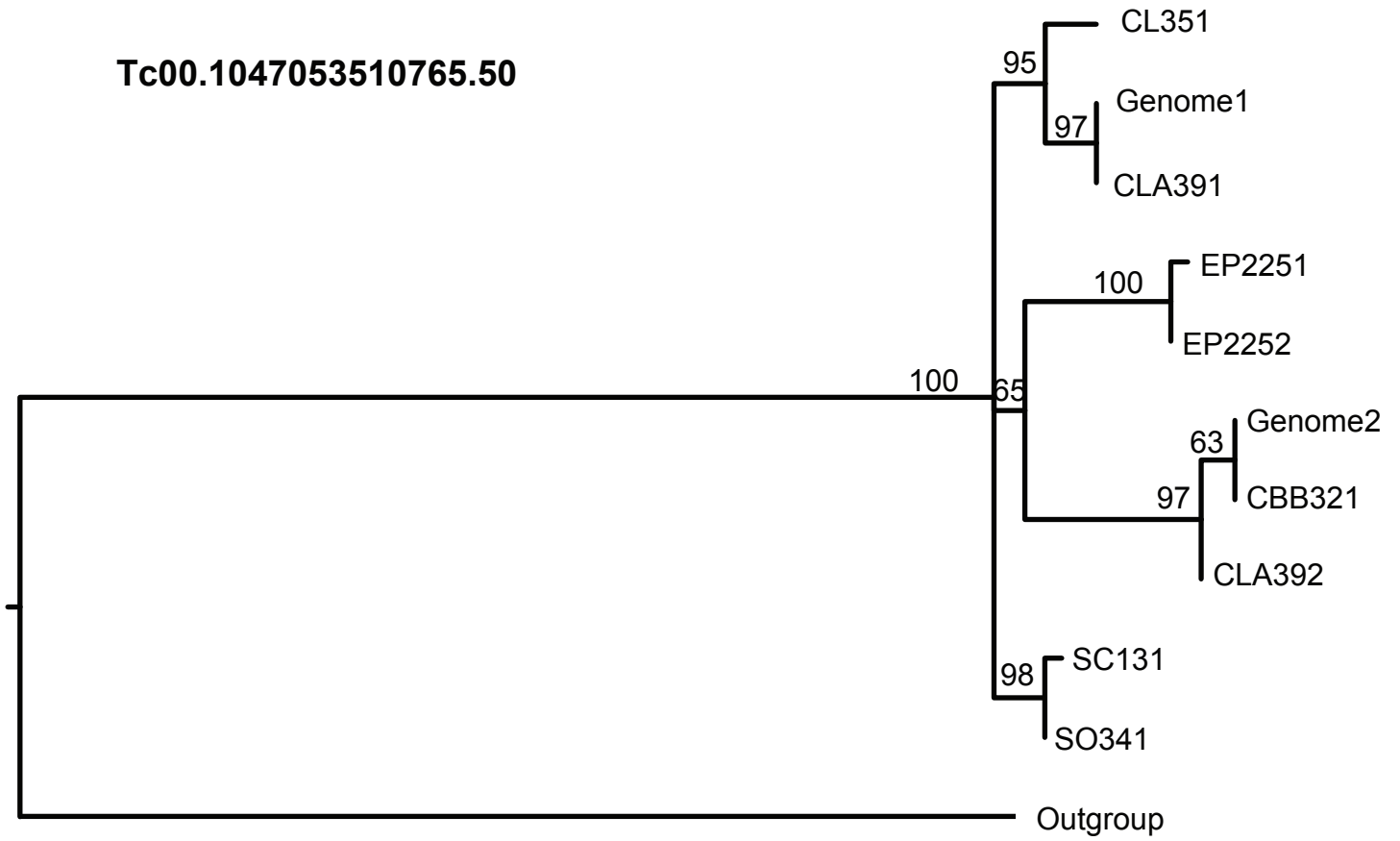

0.009 substitutions/site

Tc00.1047053509967.50

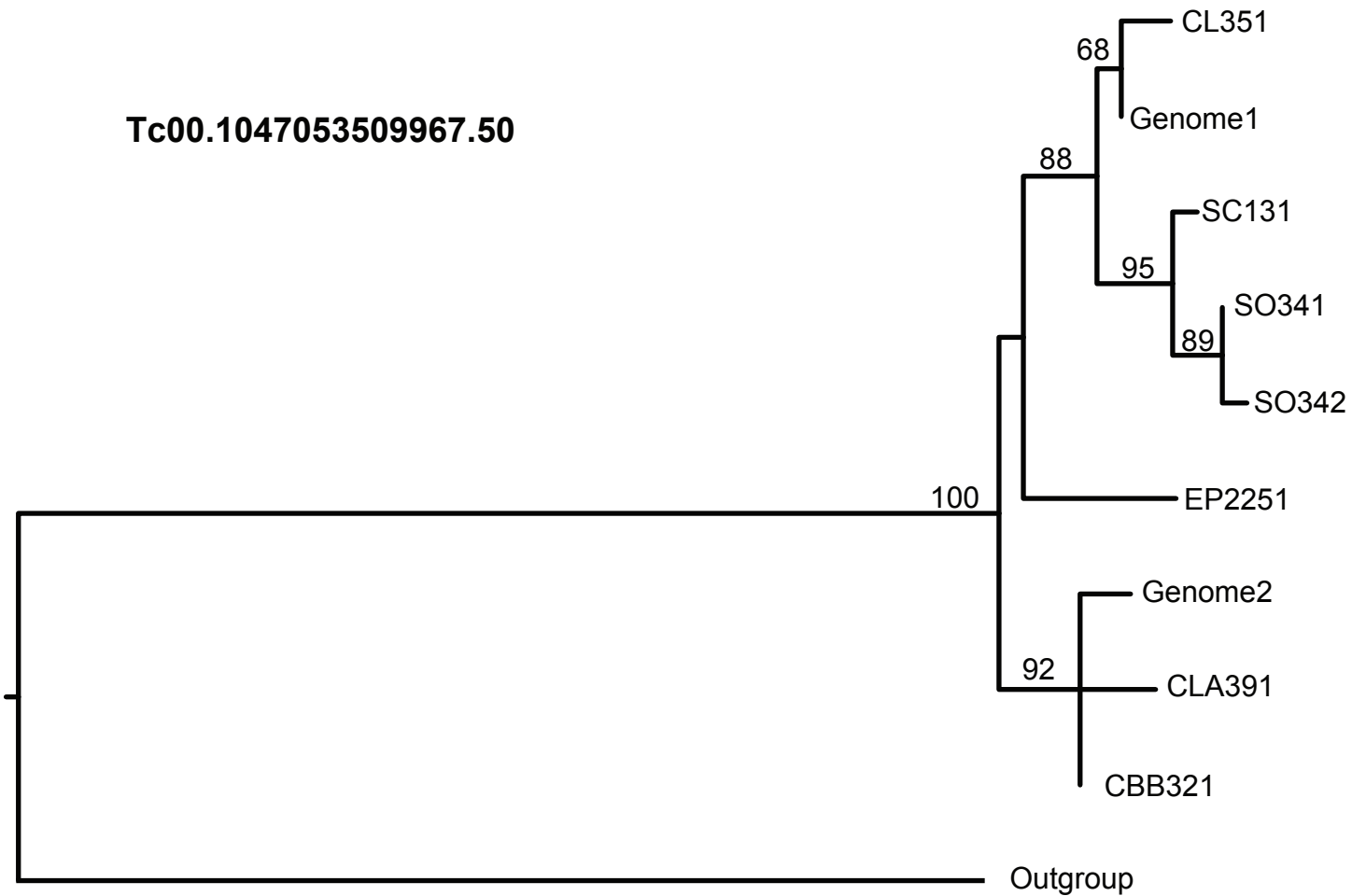

0.009 substitutions/site

Tc00.1047053510101.480

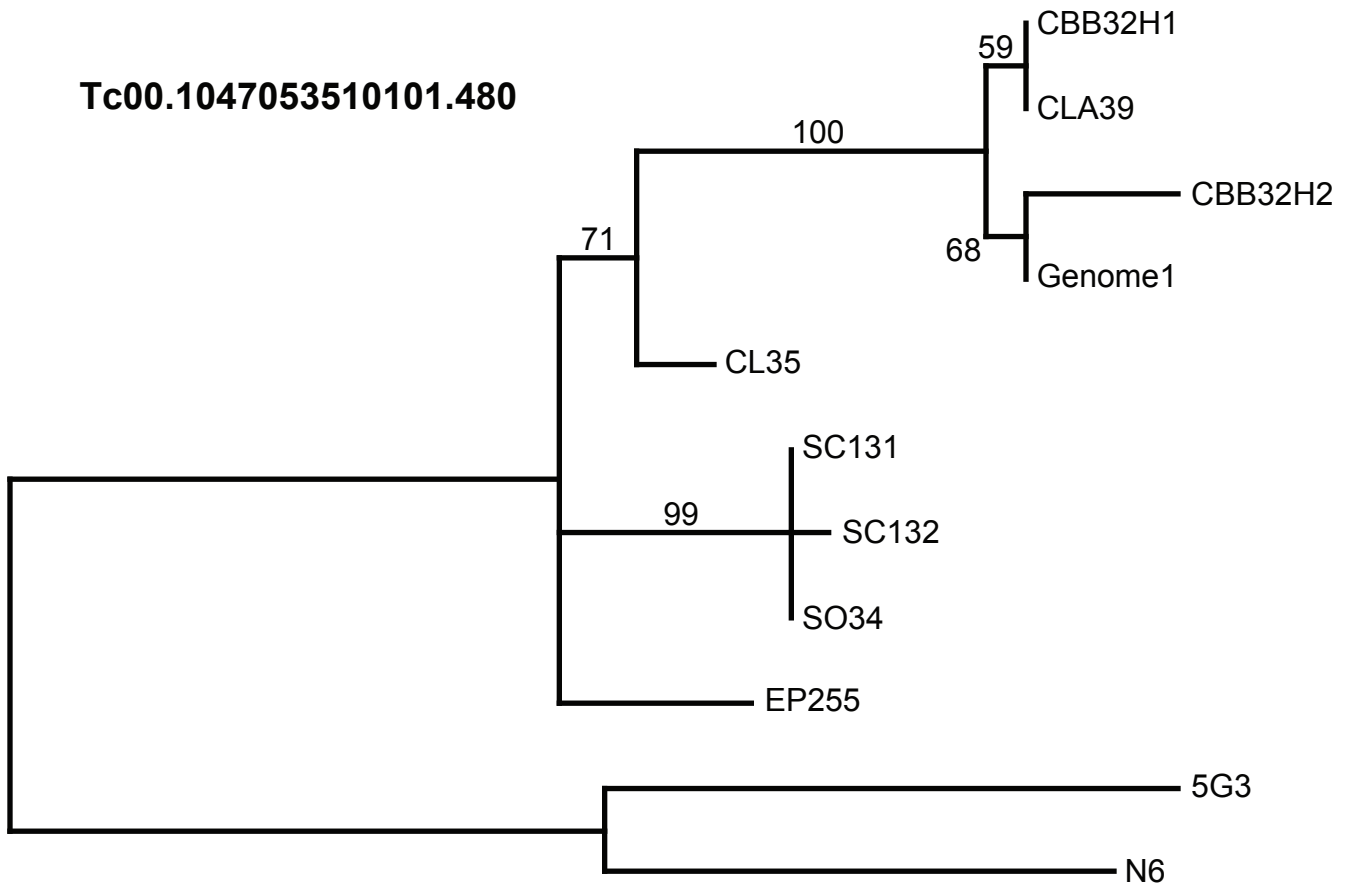

0.005 substitutions/site

Tc00.1047053506525.150

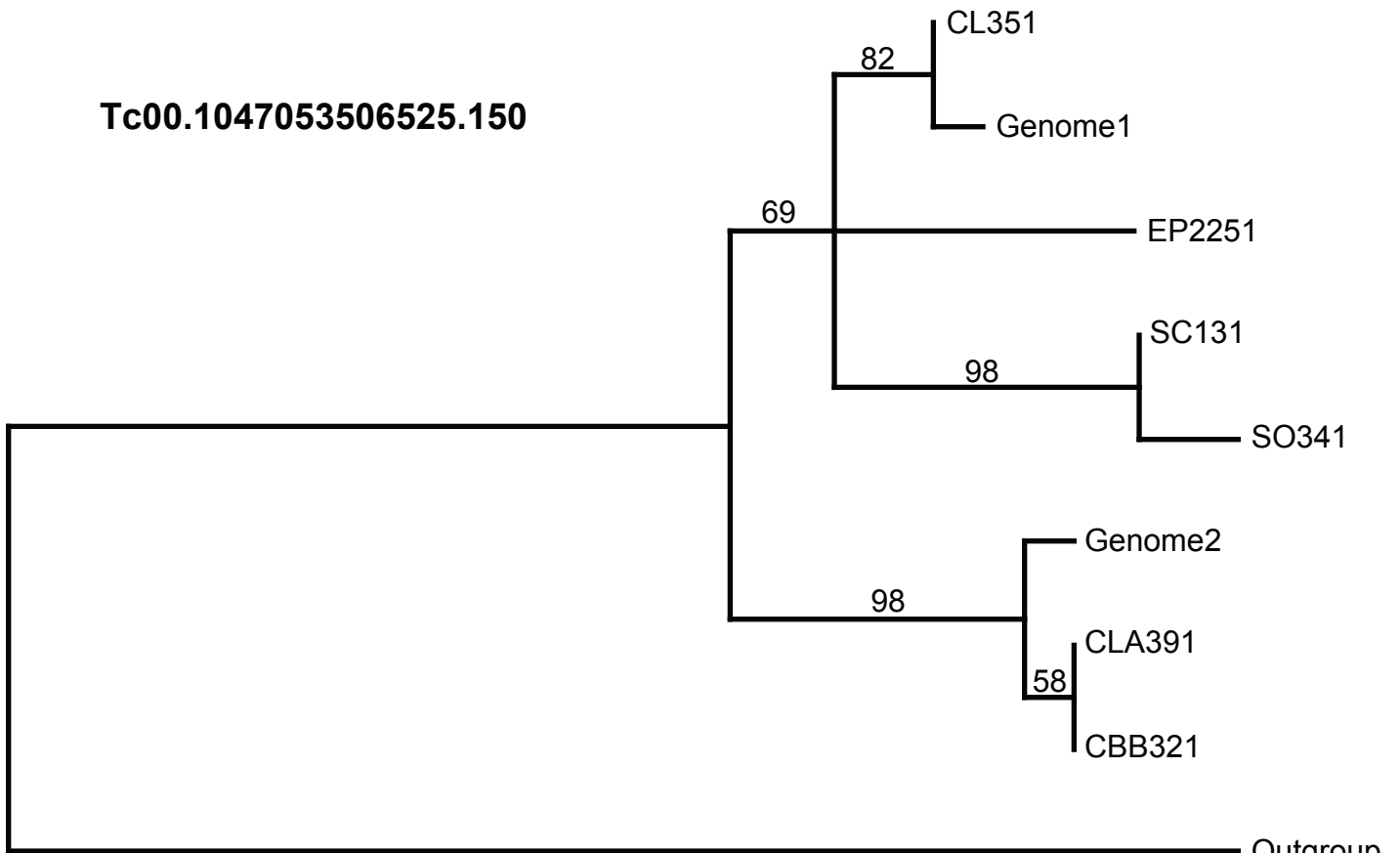

0.005 substitutions/site

Tc00.1047053504045.100

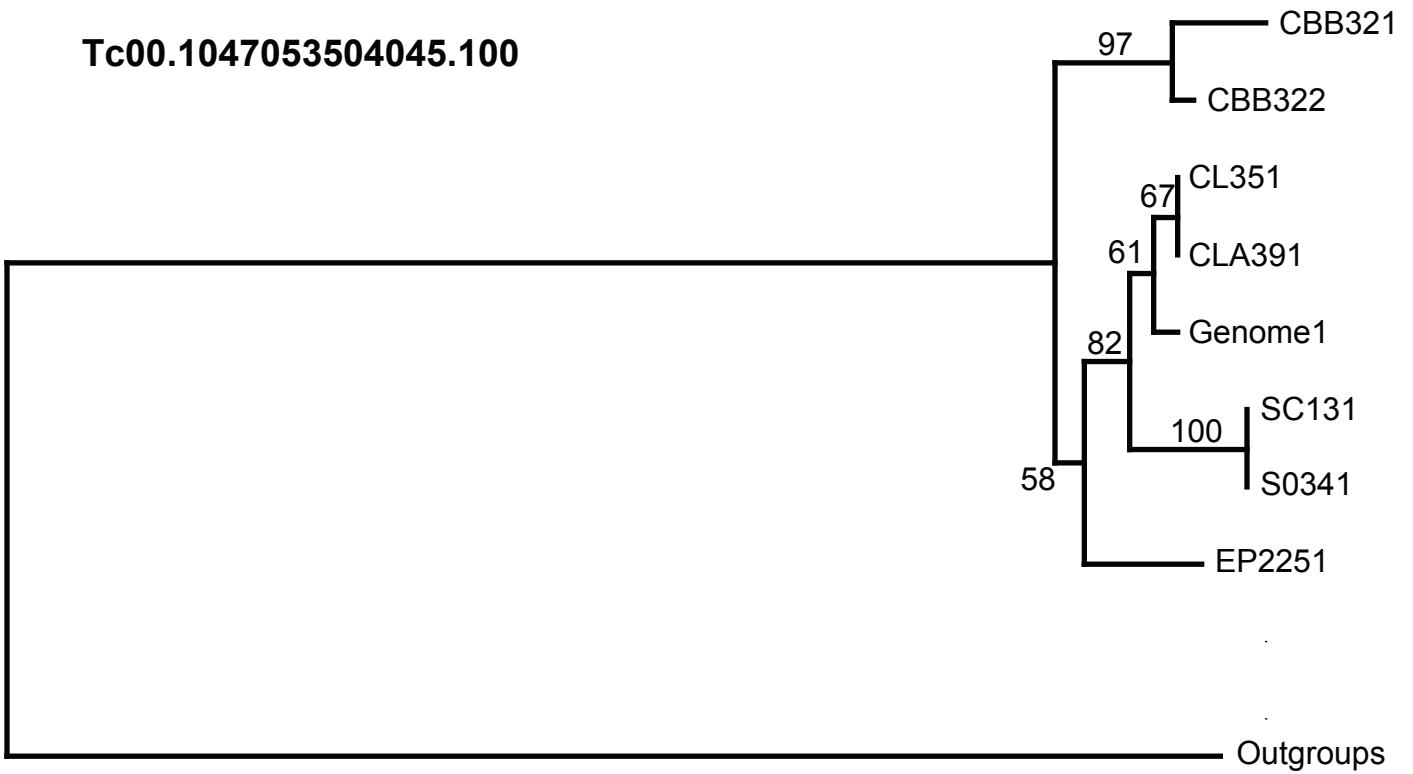

— 0.005 substitutions/site

Tc00.1047053504057.80

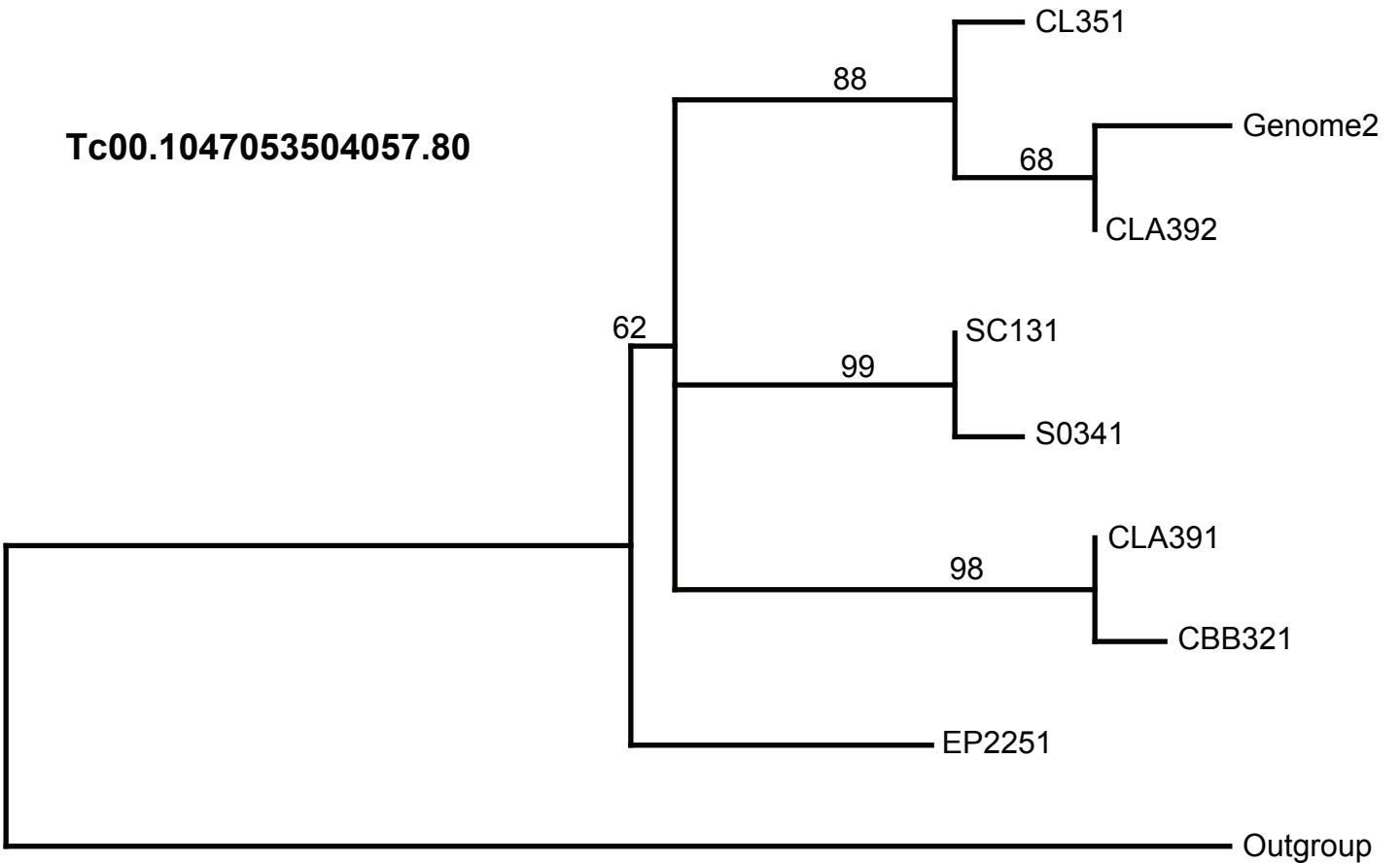

— 0.005 substitutions/site

Tc00.1047053510877.190

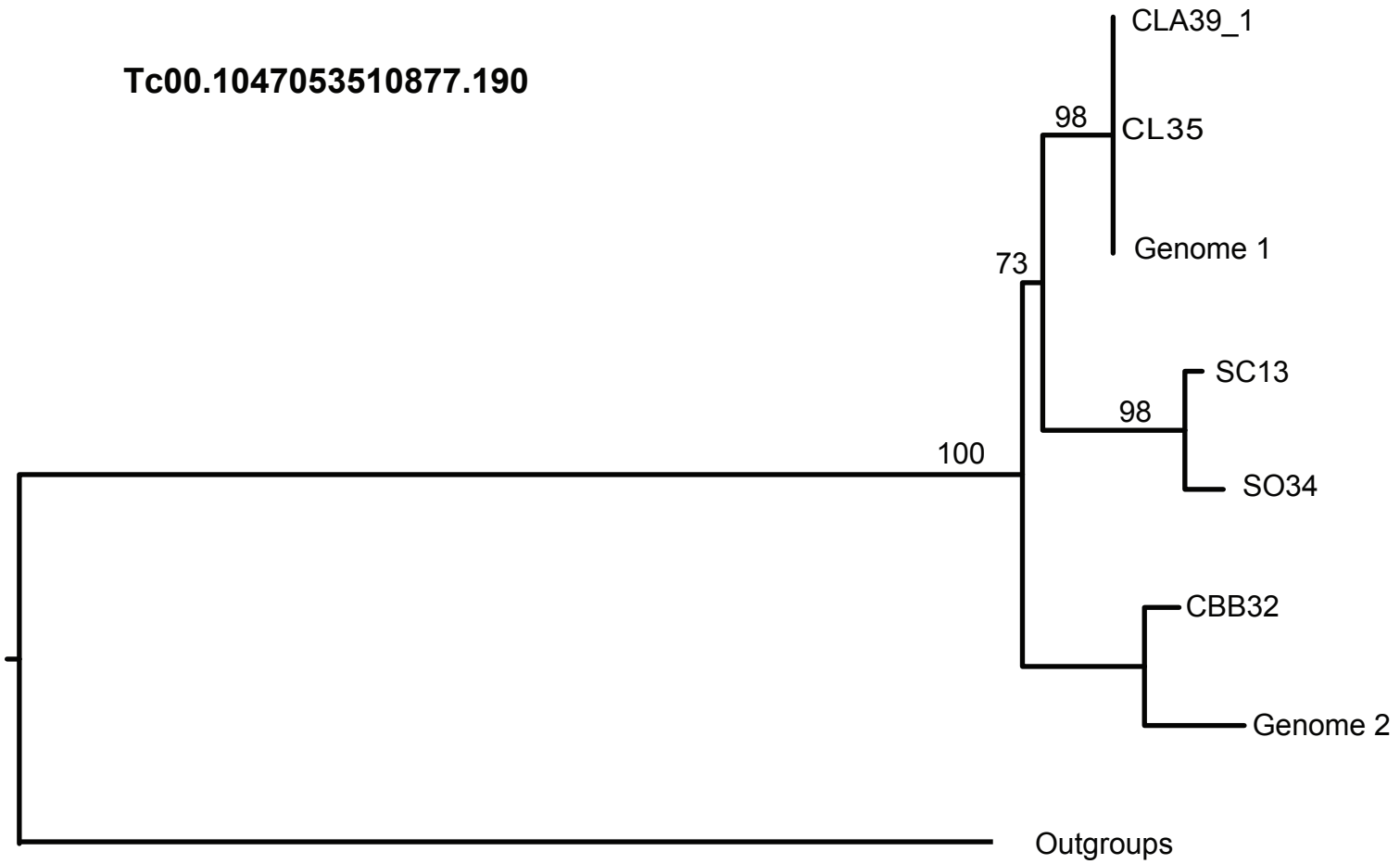

0.02 substitutions/site

Tc00.1047053506739.20

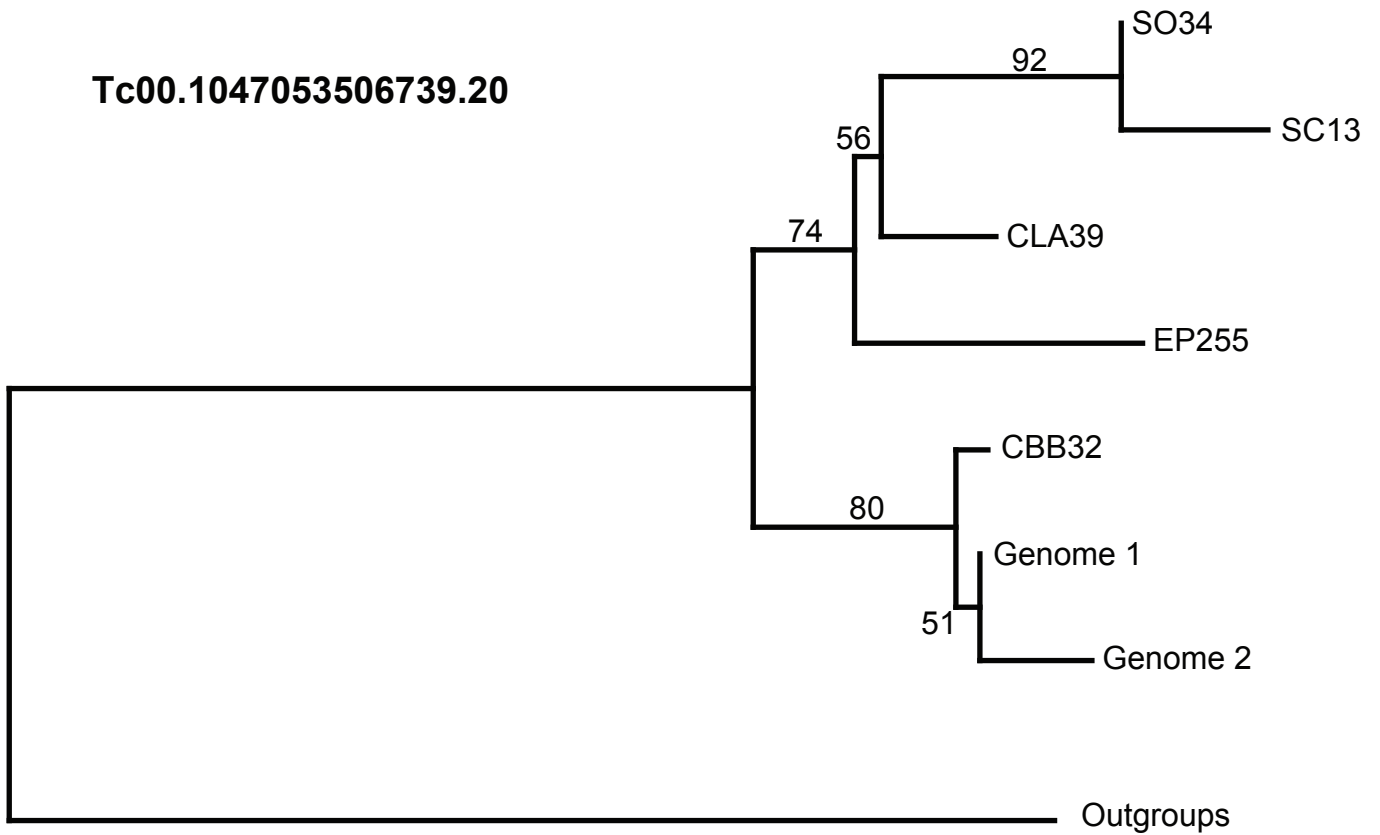

0.01 substitutions/site

Tc00.1047053509007.30

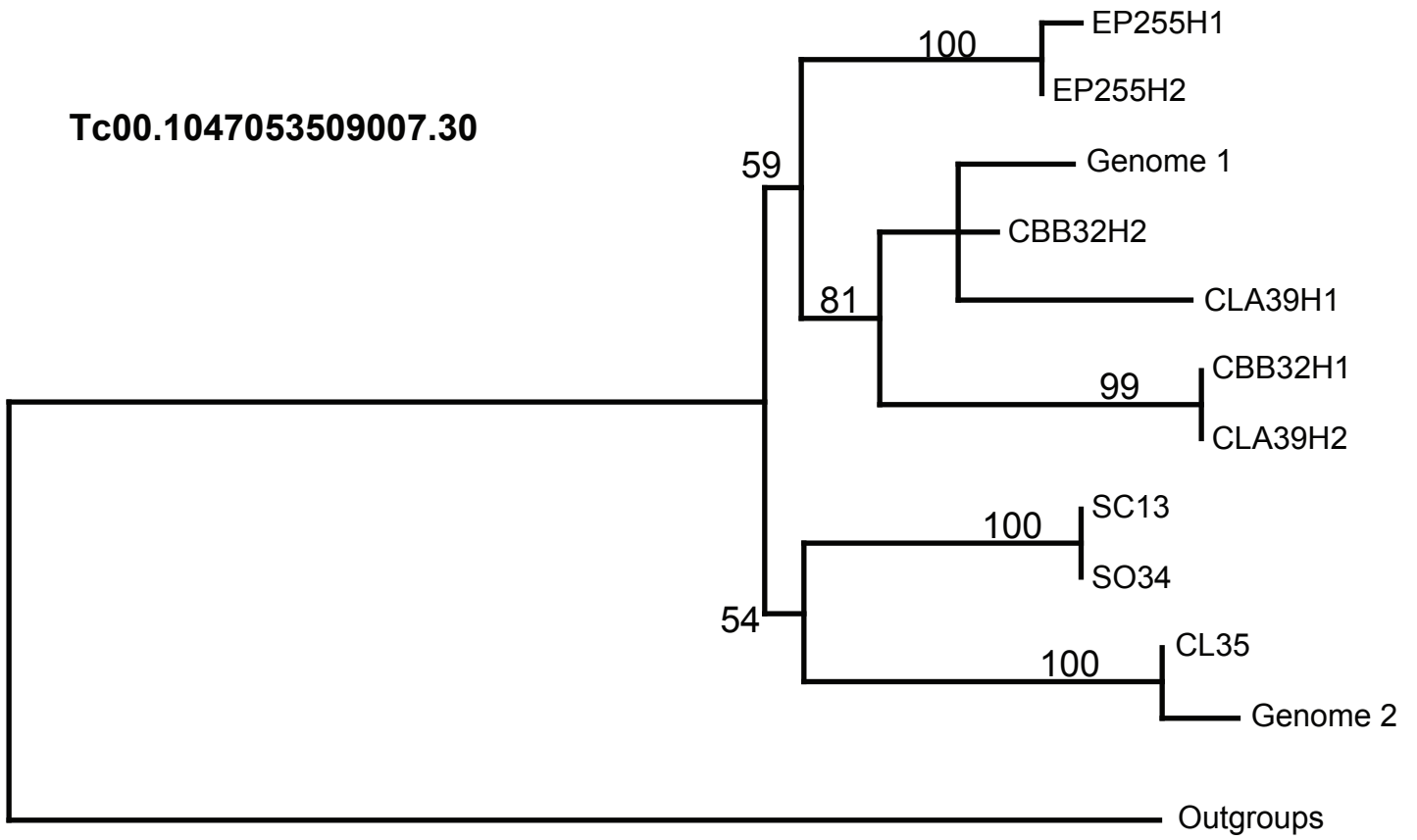

0.005 substitutions/site

Tc00.1047053506247.200

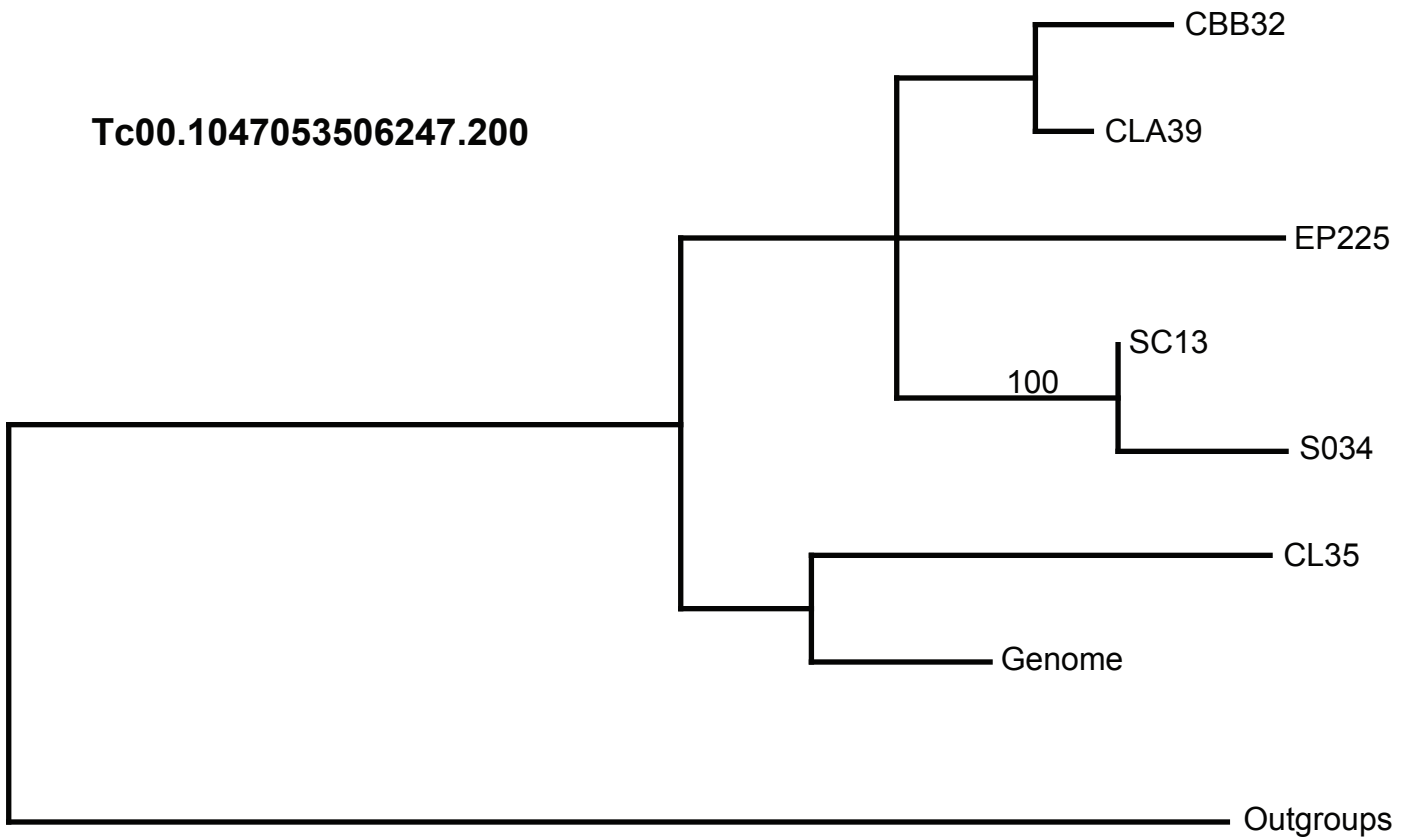

0.005 substitutions/site

Tc00.1047053509105.70

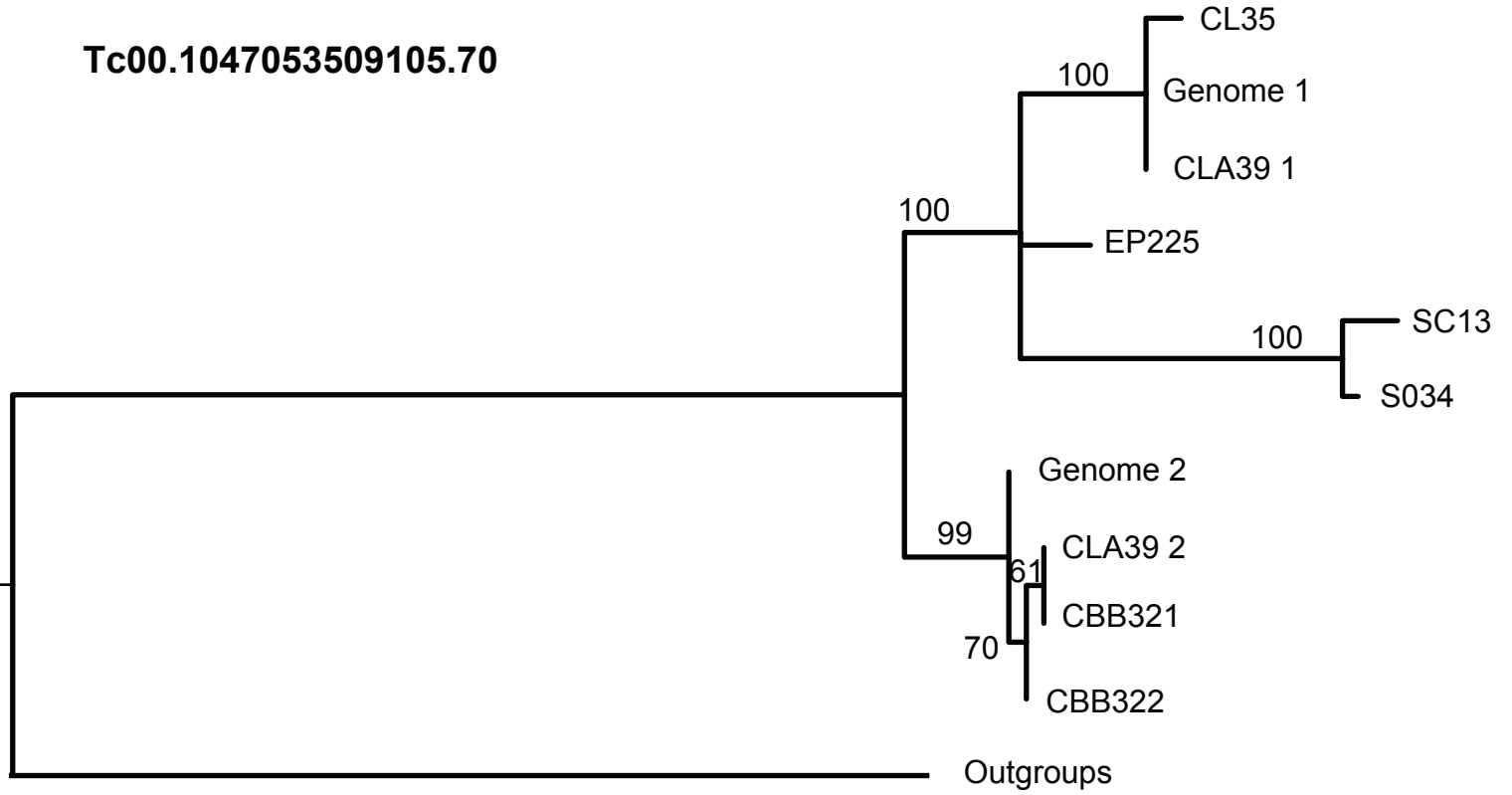

0.009 substitutions/site

HSP70

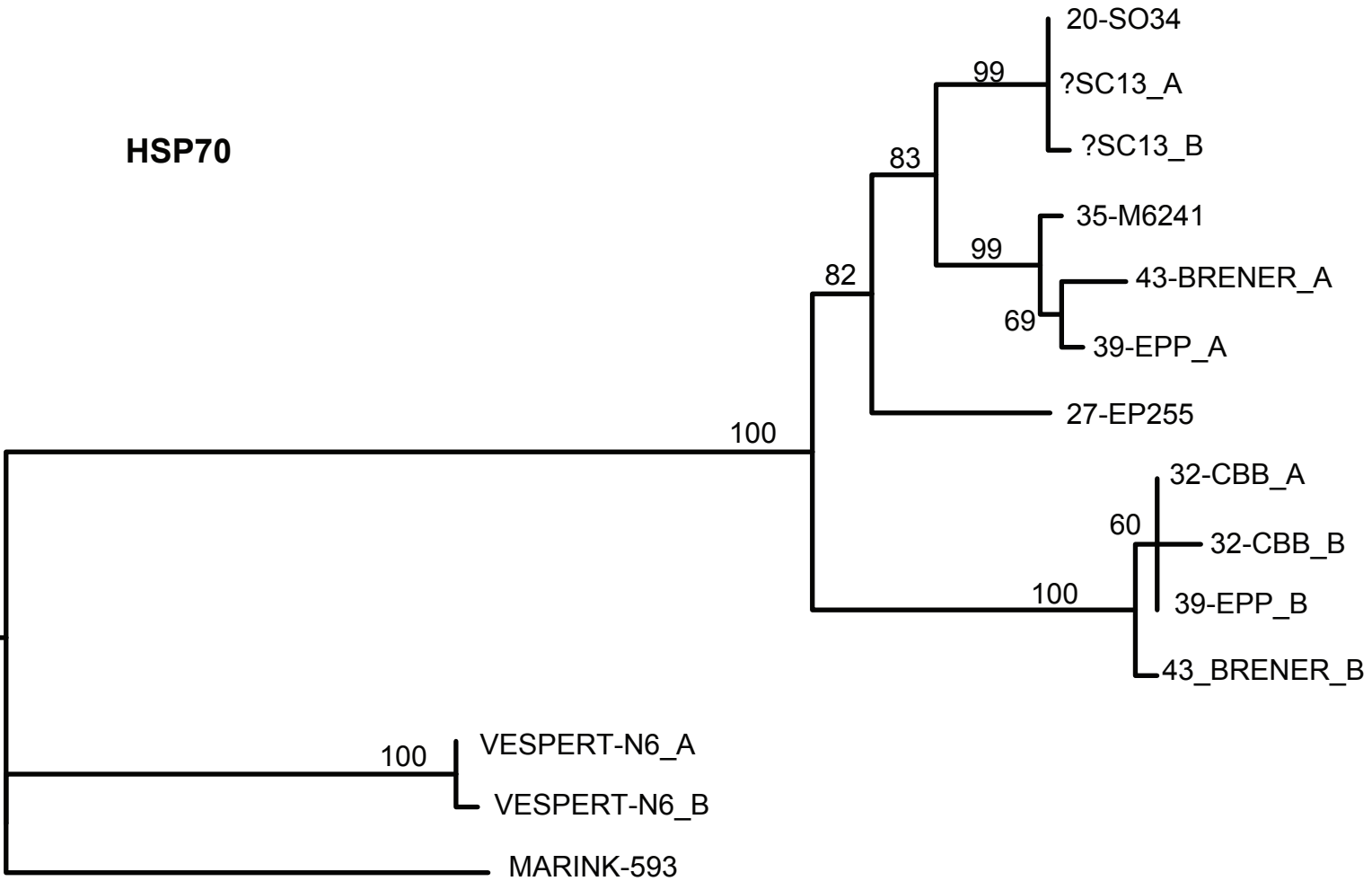

0.02 substitutions/site