

# KEGG pathways for *Trichuris suis*

March 24, 2011

## List of Figures

1	ko01110 Biosynthesis of secondary metabolites . . . . .	2
2	ko05200 Pathways in cancer . . . . .	3
3	ko01120 Microbial metabolism in diverse environments . . . . .	4
4	ko05016 Huntington's disease . . . . .	5
5	ko00190 Oxidative phosphorylation . . . . .	6
6	ko03010 Ribosome . . . . .	7
7	ko05010 Alzheimer's disease . . . . .	8
8	ko05012 Parkinson's disease . . . . .	9
9	ko04010 MAPK signaling pathway . . . . .	10
10	ko00230 Purine metabolism . . . . .	11
11	ko04141 Protein processing in endoplasmic reticulum . . . . .	12
12	ko04110 Cell cycle . . . . .	13
13	ko00240 Pyrimidine metabolism . . . . .	14
14	ko04810 Regulation of actin cytoskeleton . . . . .	15
15	ko04120 Ubiquitin mediated proteolysis . . . . .	16
16	ko04310 Wnt signaling pathway . . . . .	17
17	ko04910 Insulin signaling pathway . . . . .	18
18	ko04510 Focal adhesion . . . . .	19
19	ko04111 Cell cycle - yeast . . . . .	20

20	ko04530 Tight junction	21
21	ko03013 RNA transport	22
22	ko04114 Oocyte meiosis	23
23	ko04145 Phagosome	24
24	ko04722 Neurotrophin signaling pathway	25
25	ko04914 Progesterone-mediated oocyte maturation	26
26	ko03050 Proteasome	27
27	ko04113 Meiosis - yeast	28
28	ko04916 Melanogenesis	29
29	ko04520 Adherens junction	30
30	ko04062 Chemokine signaling pathway	31
31	ko04144 Endocytosis	32
32	ko04020 Calcium signaling pathway	33
33	ko05211 Renal cell carcinoma	34
34	ko04360 Axon guidance	35
35	ko04670 Leukocyte transendothelial migration	36
36	ko00510 N-Glycan biosynthesis	37
37	ko04666 Fc gamma R-mediated phagocytosis	38
38	ko05215 Prostate cancer	39
39	ko04012 ErbB signaling pathway	40
40	ko05210 Colorectal cancer	41
41	ko04080 Neuroactive ligand-receptor interaction	42
42	ko04660 T cell receptor signaling pathway	43
43	ko05100 Bacterial invasion of epithelial cells	44
44	ko04350 TGF-beta signaling pathway	45
45	ko05160 Hepatitis C	46
46	ko04150 mTOR signaling pathway	47
47	ko05120 Epithelial cell signaling in Helicobacter pylori infection	48
48	ko05212 Pancreatic cancer	49
49	ko00010 Glycolysis / Gluconeogenesis	50
50	ko03030 DNA replication	51

51	ko04070 Phosphatidylinositol signaling system . . . . .	52
52	ko00970 Aminoacyl-tRNA biosynthesis . . . . .	53
53	ko05110 Vibrio cholerae infection . . . . .	54
54	ko05220 Chronic myeloid leukemia . . . . .	55
55	ko00520 Amino sugar and nucleotide sugar metabolism . . . . .	56
56	ko00280 Valine, leucine and isoleucine degradation . . . . .	57
57	ko04912 GnRH signaling pathway . . . . .	58
58	ko05131 Shigellosis . . . . .	59
59	ko04142 Lysosome . . . . .	60
60	ko00020 Citrate cycle (TCA cycle) . . . . .	61
61	ko05213 Endometrial cancer . . . . .	62
62	ko03020 RNA polymerase . . . . .	63
63	ko05145 Toxoplasmosis . . . . .	64
64	ko04340 Hedgehog signaling pathway . . . . .	65
65	ko04270 Vascular smooth muscle contraction . . . . .	66
66	ko04920 Adipocytokine signaling pathway . . . . .	67
67	ko05142 Chagas disease (American trypanosomiasis) . . . . .	68
68	ko03420 Nucleotide excision repair . . . . .	69
69	ko05223 Non-small cell lung cancer . . . . .	70
70	ko00562 Inositol phosphate metabolism . . . . .	71
71	ko05130 Pathogenic Escherichia coli infection . . . . .	72
72	ko05217 Basal cell carcinoma . . . . .	73
73	ko00500 Starch and sucrose metabolism . . . . .	74
74	ko03022 Basal transcription factors . . . . .	75
75	ko04260 Cardiac muscle contraction . . . . .	76
76	ko05214 Glioma . . . . .	77
77	ko05146 Amoebiasis . . . . .	78
78	ko04380 Osteoclast differentiation . . . . .	79
79	ko05222 Small cell lung cancer . . . . .	80
80	ko04972 Pancreatic secretion . . . . .	81
81	ko00620 Pyruvate metabolism . . . . .	82

82	ko00564 Glycerophospholipid metabolism	83
83	ko04664 Fc epsilon RI signaling pathway	84
84	ko04330 Notch signaling pathway	85
85	ko04370 VEGF signaling pathway	86
86	ko04662 B cell receptor signaling pathway	87
87	ko04720 Long-term potentiation	88
88	ko04974 Protein digestion and absorption	89
89	ko00640 Propanoate metabolism	90
90	ko04540 Gap junction	91
91	ko04730 Long-term depression	92
92	ko00250 Alanine, aspartate and glutamate metabolism	93
93	ko04962 Vasopressin-regulated water reabsorption	94
94	ko00030 Pentose phosphate pathway	95
95	ko00513 Various types of N-glycan biosynthesis	96
96	ko00380 Tryptophan metabolism	97
97	ko04612 Antigen processing and presentation	98
98	ko00480 Glutathione metabolism	99
99	ko00650 Butanoate metabolism	100
100	ko03320 PPAR signaling pathway	101
101	ko05323 Rheumatoid arthritis	102
102	ko02010 ABC transporters	103
103	ko00051 Fructose and mannose metabolism	104
104	ko04630 Jak-STAT signaling pathway	105
105	ko05221 Acute myeloid leukemia	106
106	ko04976 Bile secretion	107
107	ko03060 Protein export	108
108	ko04650 Natural killer cell mediated cytotoxicity	109
109	ko04115 p53 signaling pathway	110
110	ko00563 Glycosylphosphatidylinositol(GPI)-anchor biosynthesis	111
111	ko00071 Fatty acid metabolism	112
112	ko00330 Arginine and proline metabolism	113

113	ko00680 Methane metabolism	114
114	ko05410 Hypertrophic cardiomyopathy (HCM)	115
115	ko04620 Toll-like receptor signaling pathway	116
116	ko05218 Melanoma	117
117	ko04130 SNARE interactions in vesicular transport	118
118	ko03410 Base excision repair	119
119	ko04971 Gastric acid secretion	120
120	ko00710 Carbon fixation in photosynthetic organisms	121
121	ko05412 Arrhythmogenic right ventricular cardiomyopathy (ARVC)	122
122	ko00270 Cysteine and methionine metabolism	123
123	ko04210 Apoptosis	124
124	ko03008 Ribosome biogenesis in eukaryotes	125
125	ko00627 Aminobenzoate degradation	126
126	ko00350 Tyrosine metabolism	127
127	ko04320 Dorso-ventral axis formation	128
128	ko05414 Dilated cardiomyopathy	129
129	ko05014 Amyotrophic lateral sclerosis (ALS)	130
130	ko03430 Mismatch repair	131
131	ko00052 Galactose metabolism	132
132	ko04140 Regulation of autophagy	133
133	ko04930 Type II diabetes mellitus	134
134	ko05216 Thyroid cancer	135
135	ko04512 ECM-receptor interaction	136
136	ko04970 Salivary secretion	137
137	ko00720 Carbon fixation pathways in prokaryotes	138
138	ko00260 Glycine, serine and threonine metabolism	139
139	ko03018 RNA degradation	140
140	ko00670 One carbon pool by folate	141
141	ko00534 Glycosaminoglycan biosynthesis - heparan sulfate	142
142	ko05416 Viral myocarditis	143
143	ko05219 Bladder cancer	144

144	ko00910 Nitrogen metabolism	145
145	ko00561 Glycerolipid metabolism	146
146	ko04966 Collecting duct acid secretion	147
147	ko04745 Phototransduction - fly	148
148	ko04960 Aldosterone-regulated sodium reabsorption	149
149	ko04973 Carbohydrate digestion and absorption	150
150	ko03015 mRNA surveillance pathway	151
151	ko00040 Pentose and glucuronate interconversions	152
152	ko00310 Lysine degradation	153
153	ko04013 MAPK signaling pathway - fly	154
154	ko00983 Drug metabolism - other enzymes	155
155	ko03440 Homologous recombination	156
156	ko00600 Sphingolipid metabolism	157
157	ko05020 Prion diseases	158
158	ko04514 Cell adhesion molecules (CAMs)	159
159	ko04710 Circadian rhythm - mammal	160
160	ko04060 Cytokine-cytokine receptor interaction	161
161	ko00630 Glyoxylate and dicarboxylate metabolism	162
162	ko00410 beta-Alanine metabolism	163
163	ko00790 Folate biosynthesis	164
164	ko00514 Other types of O-glycan biosynthesis	165
165	ko04610 Complement and coagulation cascades	166
166	ko00360 Phenylalanine metabolism	167
167	ko04011 MAPK signaling pathway - yeast	168
168	ko00900 Terpenoid backbone biosynthesis	169
169	ko04622 RIG-I-like receptor signaling pathway	170
170	ko00290 Valine, leucine and isoleucine biosynthesis	171
171	ko00860 Porphyrin and chlorophyll metabolism	172
172	ko04626 Plant-pathogen interaction	173
173	ko00980 Metabolism of xenobiotics by cytochrome P450	174
174	ko00760 Nicotinate and nicotinamide metabolism	175

175	ko00450 Selenocompound metabolism	176
176	ko04623 Cytosolic DNA-sensing pathway	177
177	ko00362 Benzoate degradation	178
178	ko00062 Fatty acid elongation in mitochondria	179
179	ko00903 Limonene and pinene degradation	180
180	ko04146 Peroxisome	181
181	ko04621 NOD-like receptor signaling pathway	182
182	ko00982 Drug metabolism - cytochrome P450	183
183	ko02020 Two-component system	184
184	ko00130 Ubiquinone and other terpenoid-quinone biosynthesis	185
185	ko00565 Ether lipid metabolism	186
186	ko04740 Olfactory transduction	187
187	ko05143 African trypanosomiasis	188
188	ko03040 Spliceosome	189
189	ko05140 Leishmaniasis	190
190	ko04964 Proximal tubule bicarbonate reclamation	191
191	ko04614 Renin-angiotensin system	192
192	ko03450 Non-homologous end-joining	193
193	ko03070 Bacterial secretion system	194
194	ko00521 Streptomycin biosynthesis	195
195	ko04940 Type I diabetes mellitus	196
196	ko00830 Retinol metabolism	197
197	ko04950 Maturity onset diabetes of the young	198
198	ko01040 Biosynthesis of unsaturated fatty acids	199
199	ko00460 Cyanoamino acid metabolism	200
200	ko00625 Chloroalkane and chloroalkene degradation	201
201	ko00363 Bisphenol degradation	202
202	ko00950 Isoquinoline alkaloid biosynthesis	203
203	ko04122 Sulfur relay system	204
204	ko00590 Arachidonic acid metabolism	205
205	ko00511 Other glycan degradation	206

206	ko00072	Synthesis and degradation of ketone bodies	207
207	ko00340	Histidine metabolism	208
208	ko00532	Glycosaminoglycan biosynthesis - chondroitin sulfate	209
209	ko00930	Caprolactam degradation	210
210	ko00281	Geraniol degradation	211
211	ko04640	Hematopoietic cell lineage	212
212	ko00960	Tropane, piperidine and pyridine alkaloid biosynthesis	213
213	ko00740	Riboflavin metabolism	214
214	ko00626	Naphthalene degradation	215
215	ko00920	Sulfur metabolism	216
216	ko00053	Ascorbate and aldarate metabolism	217
217	ko00140	Steroid hormone biosynthesis	218
218	ko00624	Polycyclic aromatic hydrocarbon degradation	219
219	ko00061	Fatty acid biosynthesis	220
220	ko05322	Systemic lupus erythematosus	221
221	ko04975	Fat digestion and absorption	222
222	ko04742	Taste transduction	223
223	ko00750	Vitamin B6 metabolism	224
224	ko00601	Glycosphingolipid biosynthesis - lacto and neolacto series	225
225	ko00430	Taurine and hypotaurine metabolism	226
226	ko04711	Circadian rhythm - fly	227
227	ko00785	Lipoic acid metabolism	228
228	ko00603	Glycosphingolipid biosynthesis - globo series	229
229	ko00643	Styrene degradation	230
230	ko04712	Circadian rhythm - plant	231
231	ko05340	Primary immunodeficiency	232
232	ko00440	Phosphonate and phosphinate metabolism	233
233	ko00730	Thiamine metabolism	234
234	ko00780	Biotin metabolism	235
235	ko00591	Linoleic acid metabolism	236
236	ko00400	Phenylalanine, tyrosine and tryptophan biosynthesis	237



237	ko00965	Betalain biosynthesis	238
238	ko00940	Phenylpropanoid biosynthesis	239
239	ko00512	Mucin type O-Glycan biosynthesis	240
240	ko05150	Staphylococcus aureus infection	241
241	ko05144	Malaria	242
242	ko00770	Pantothenate and CoA biosynthesis	243
243	ko00471	D-Glutamine and D-glutamate metabolism	244
244	ko00604	Glycosphingolipid biosynthesis - ganglio series	245
245	ko00901	Indole alkaloid biosynthesis	246
246	ko00945	Stilbenoid, diarylheptanoid and gingerol biosynthesis	247
247	ko01055	Biosynthesis of vancomycin group antibiotics	248
248	ko04112	Cell cycle - Caulobacter	249
249	ko04744	Phototransduction	250
250	ko00533	Glycosaminoglycan biosynthesis - keratan sulfate	251
251	ko00642	Ethylbenzene degradation	252
252	ko00100	Steroid biosynthesis	253
253	ko01051	Biosynthesis of ansamycins	254
254	ko00660	C5-Branched dibasic acid metabolism	255
255	ko00524	Butirosin and neomycin biosynthesis	256
256	ko00944	Flavone and flavonol biosynthesis	257
257	ko00592	alpha-Linolenic acid metabolism	258
258	ko00401	Novobiocin biosynthesis	259
259	ko00531	Glycosaminoglycan degradation	260
260	ko00908	Zeatin biosynthesis	261
261	ko00523	Polyketide sugar unit biosynthesis	262
262	ko04977	Vitamin digestion and absorption	263

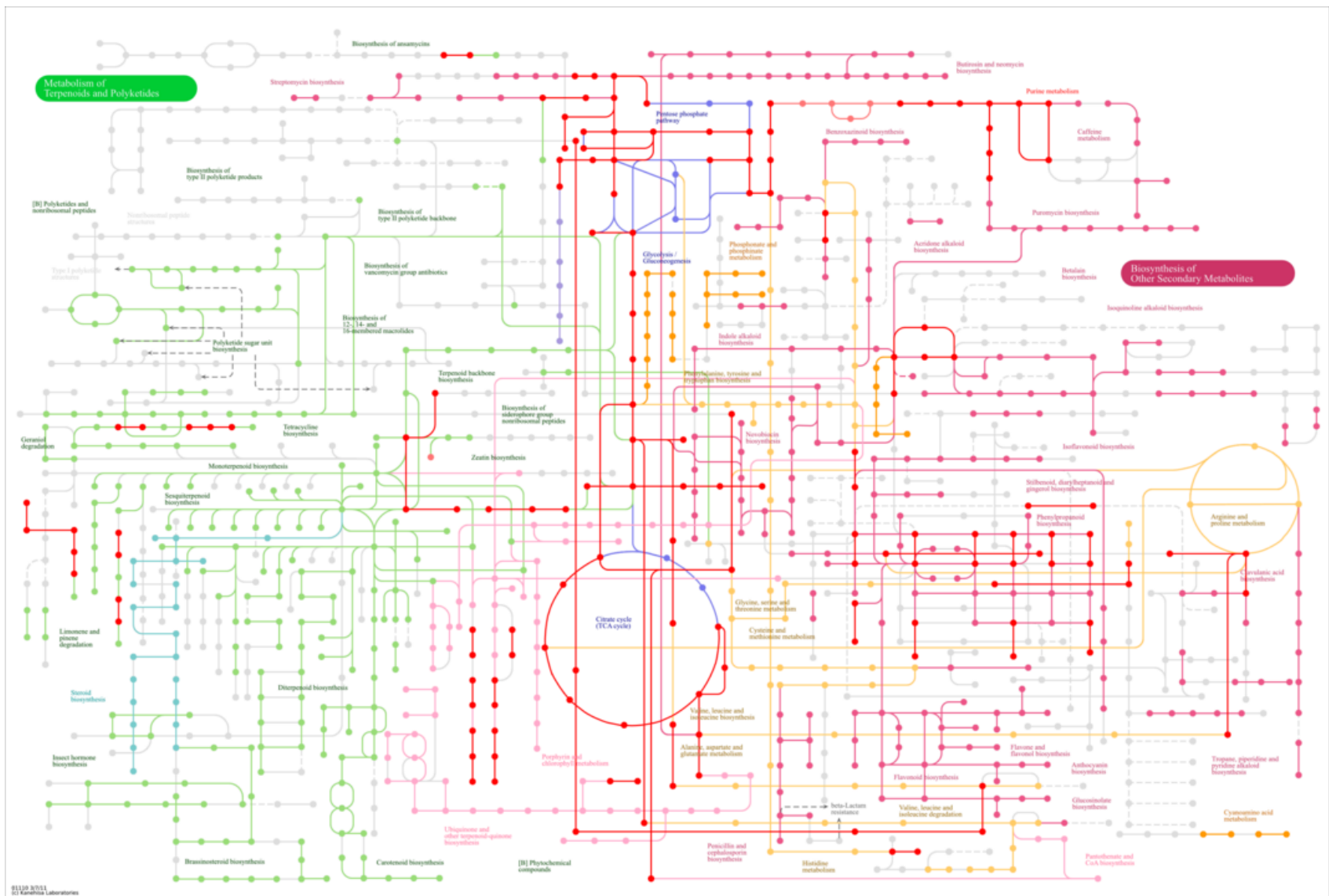

Figure 1: ko01110 Biosynthesis of secondary metabolites

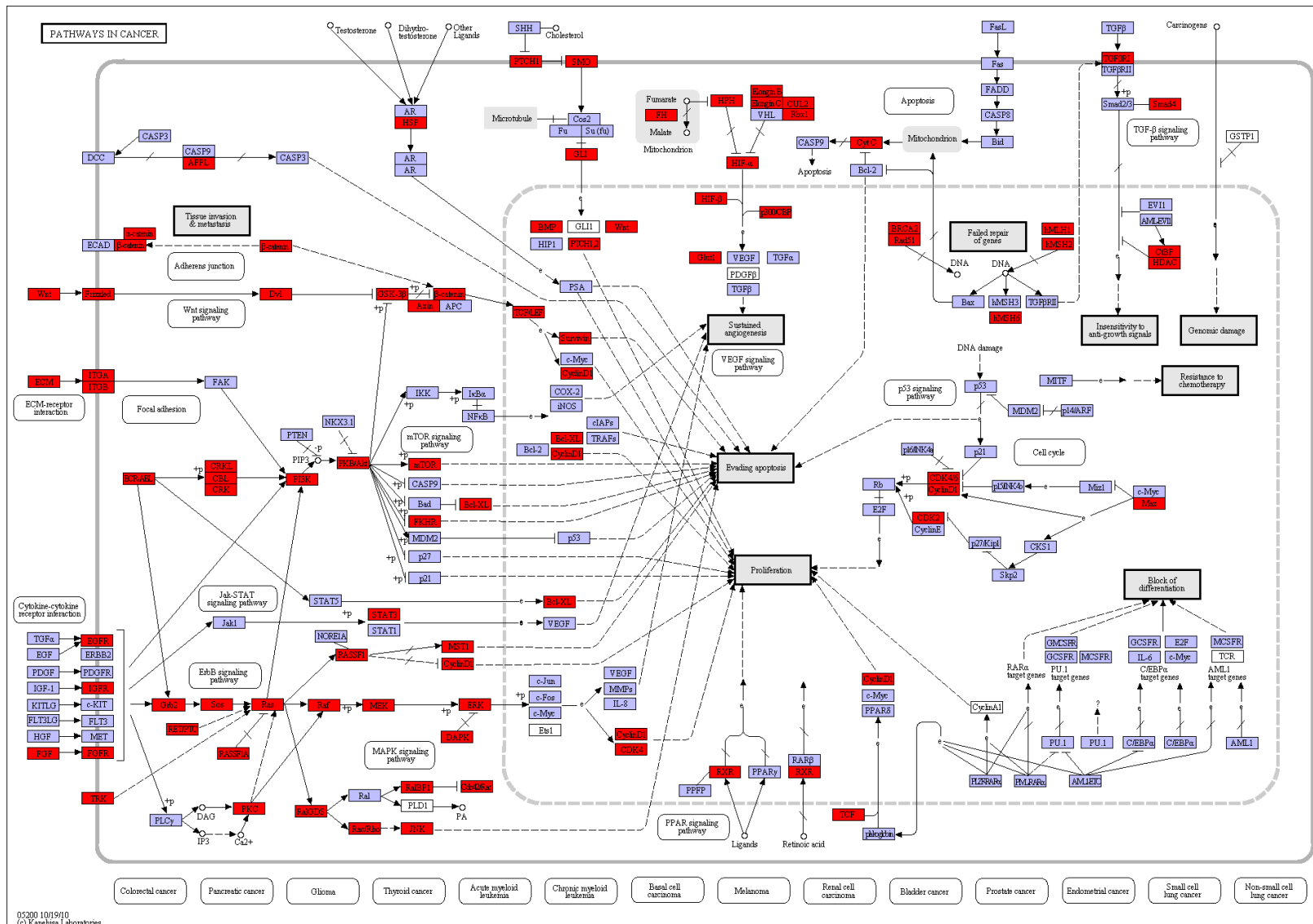

Figure 2: ko05200 Pathways in cancer

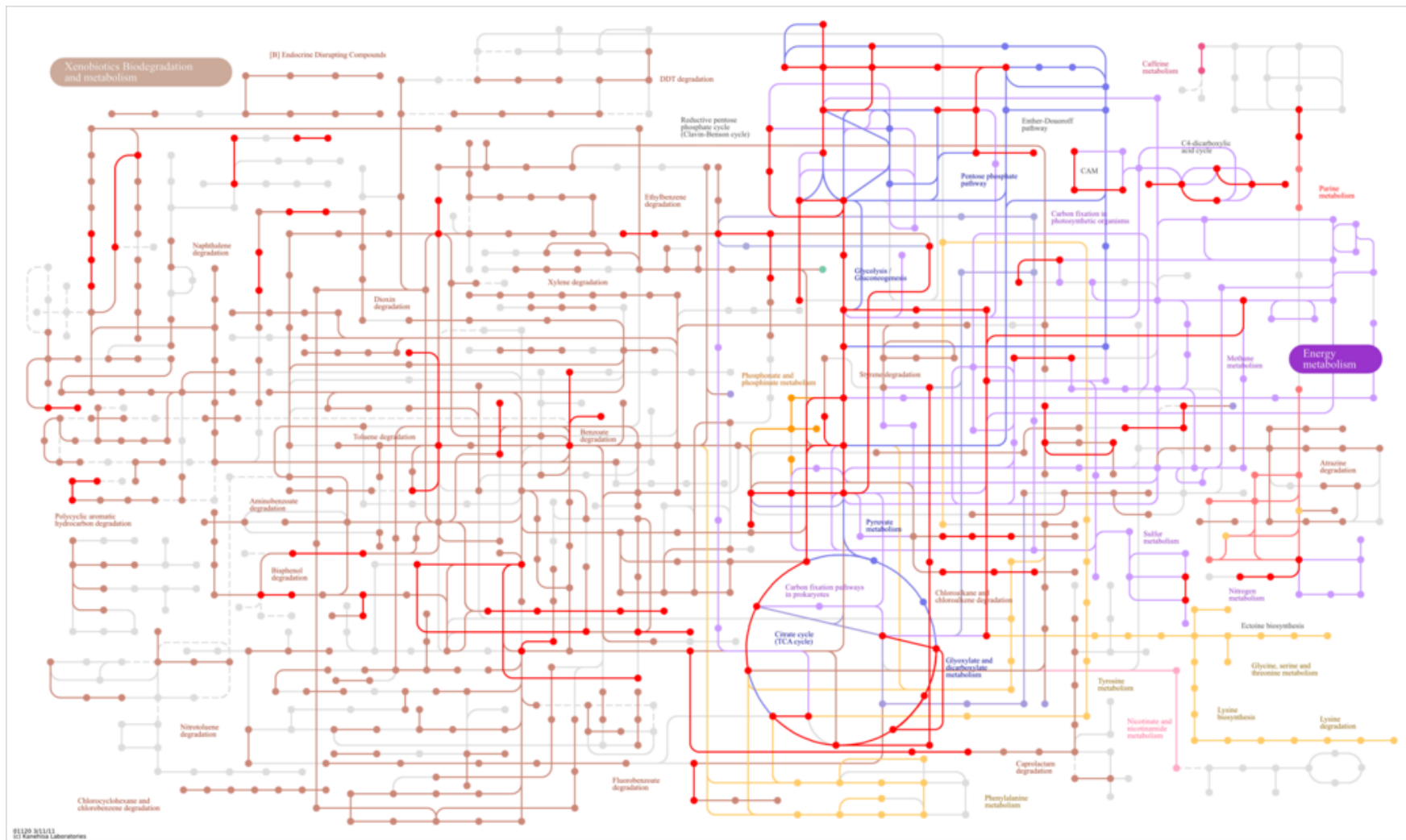

Figure 3: ko01120 Microbial metabolism in diverse environments

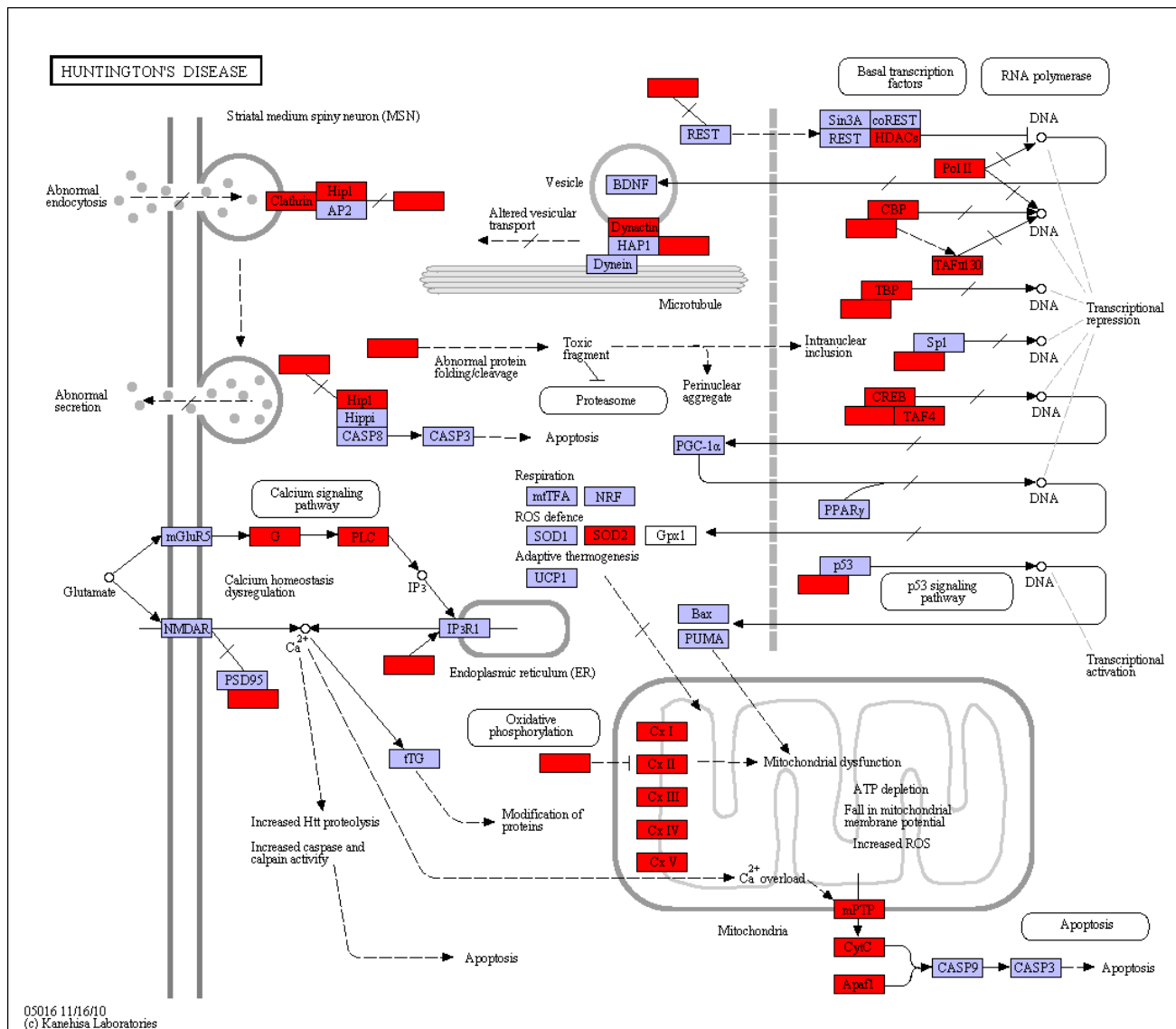

Figure 4: ko05016 Huntington's disease



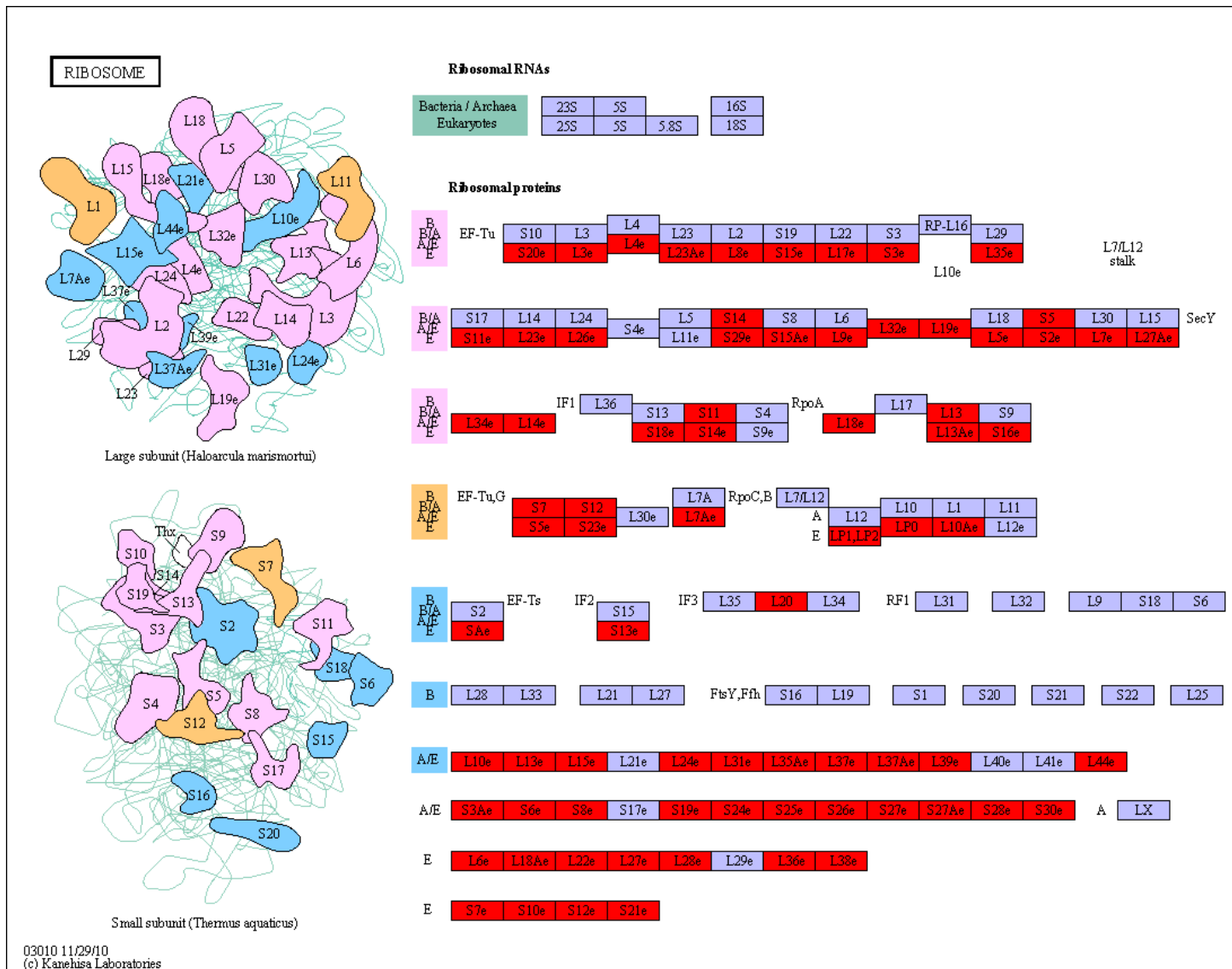

Figure 6: ko03010 Ribosome





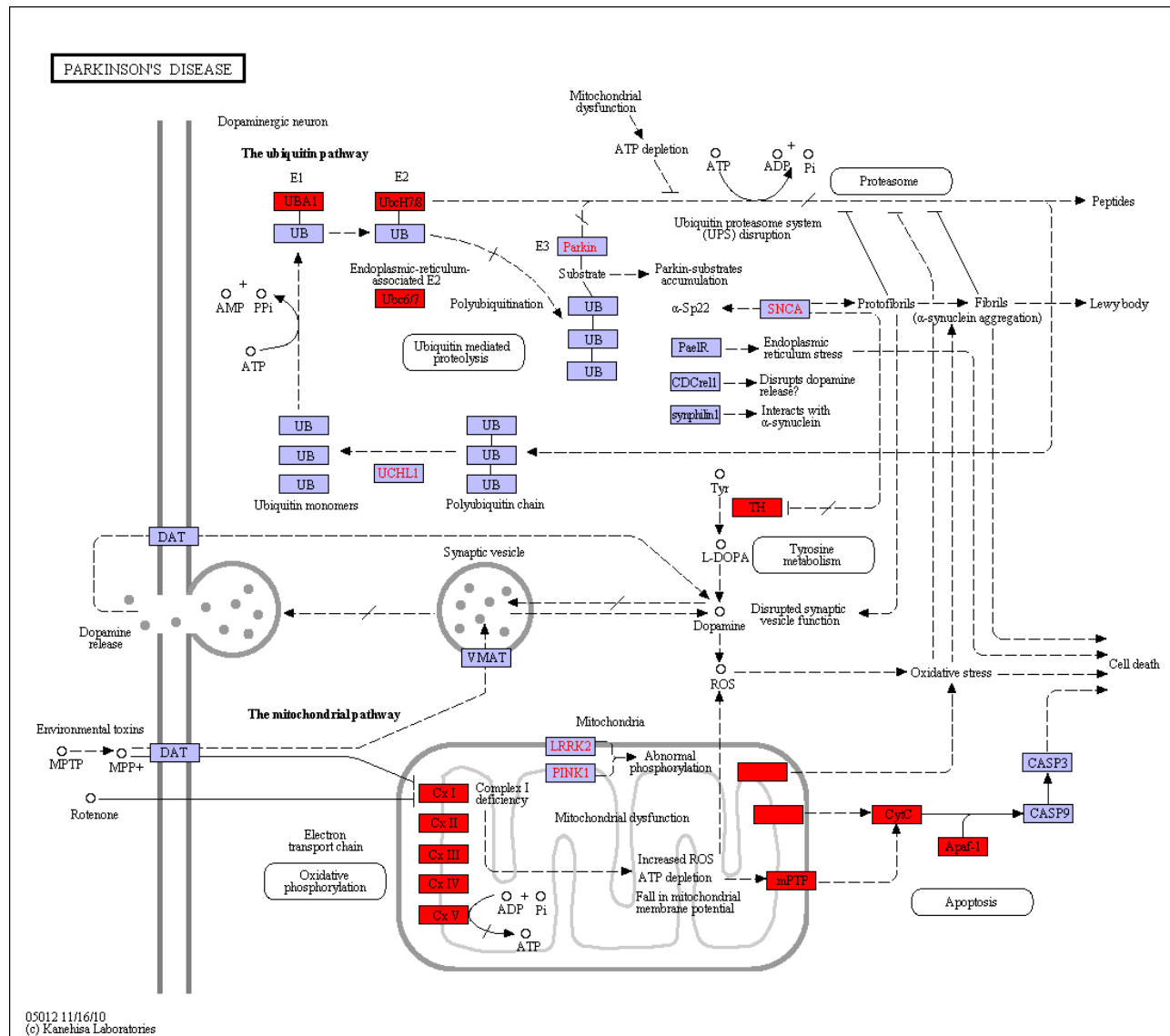

Figure 8: ko05012 Parkinson's disease

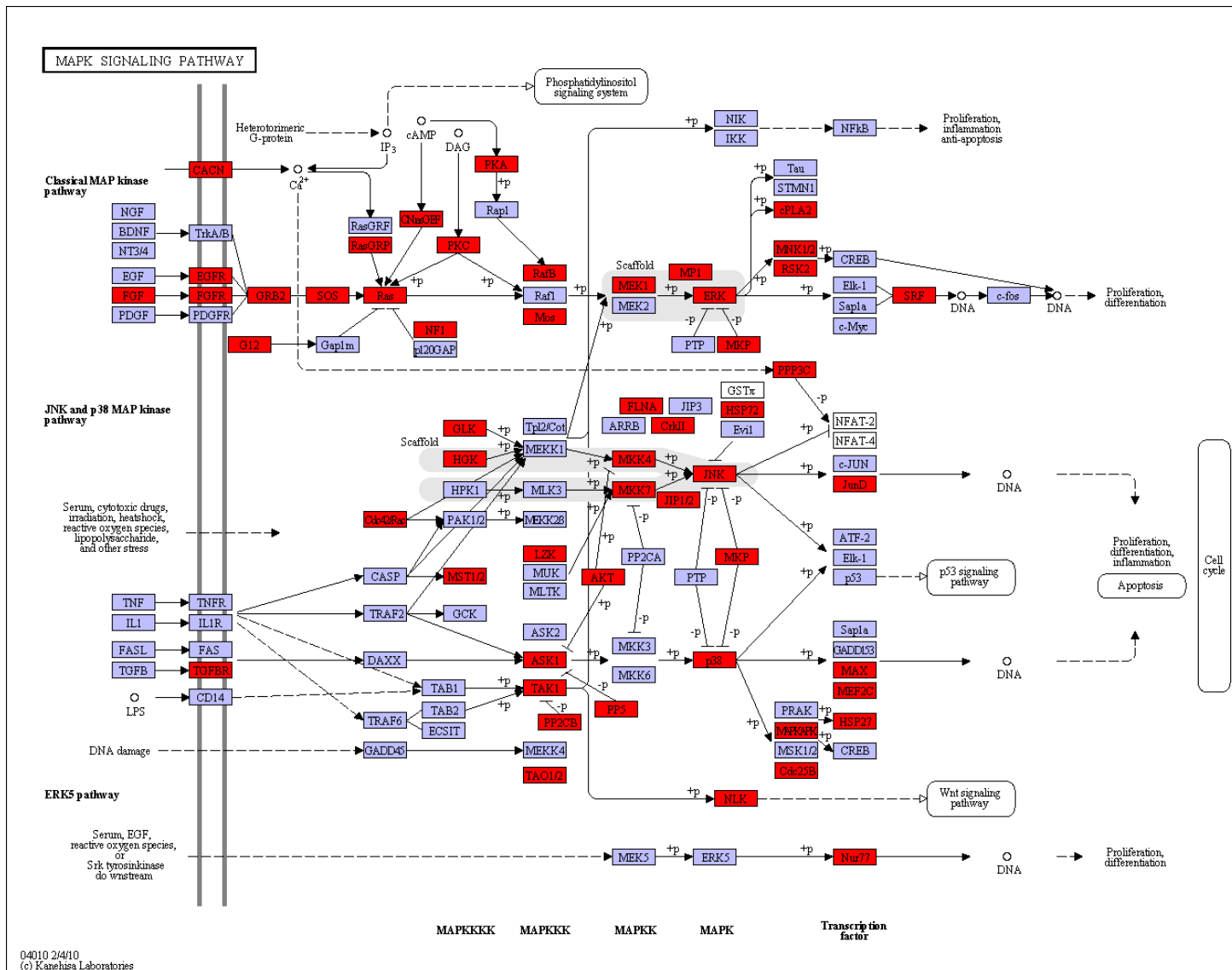

Figure 9: ko04010 MAPK signaling pathway





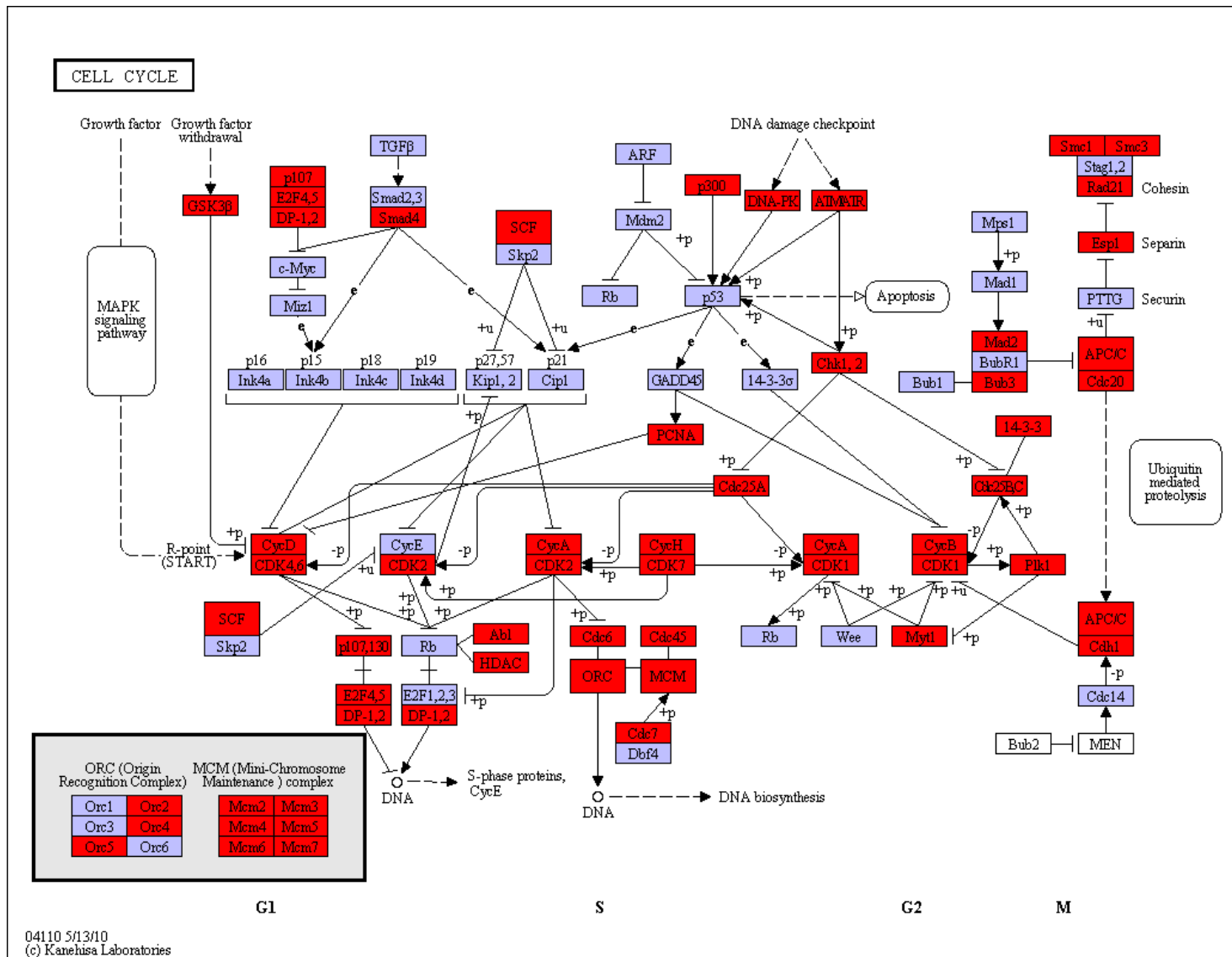

Figure 12: ko04110 Cell cycle



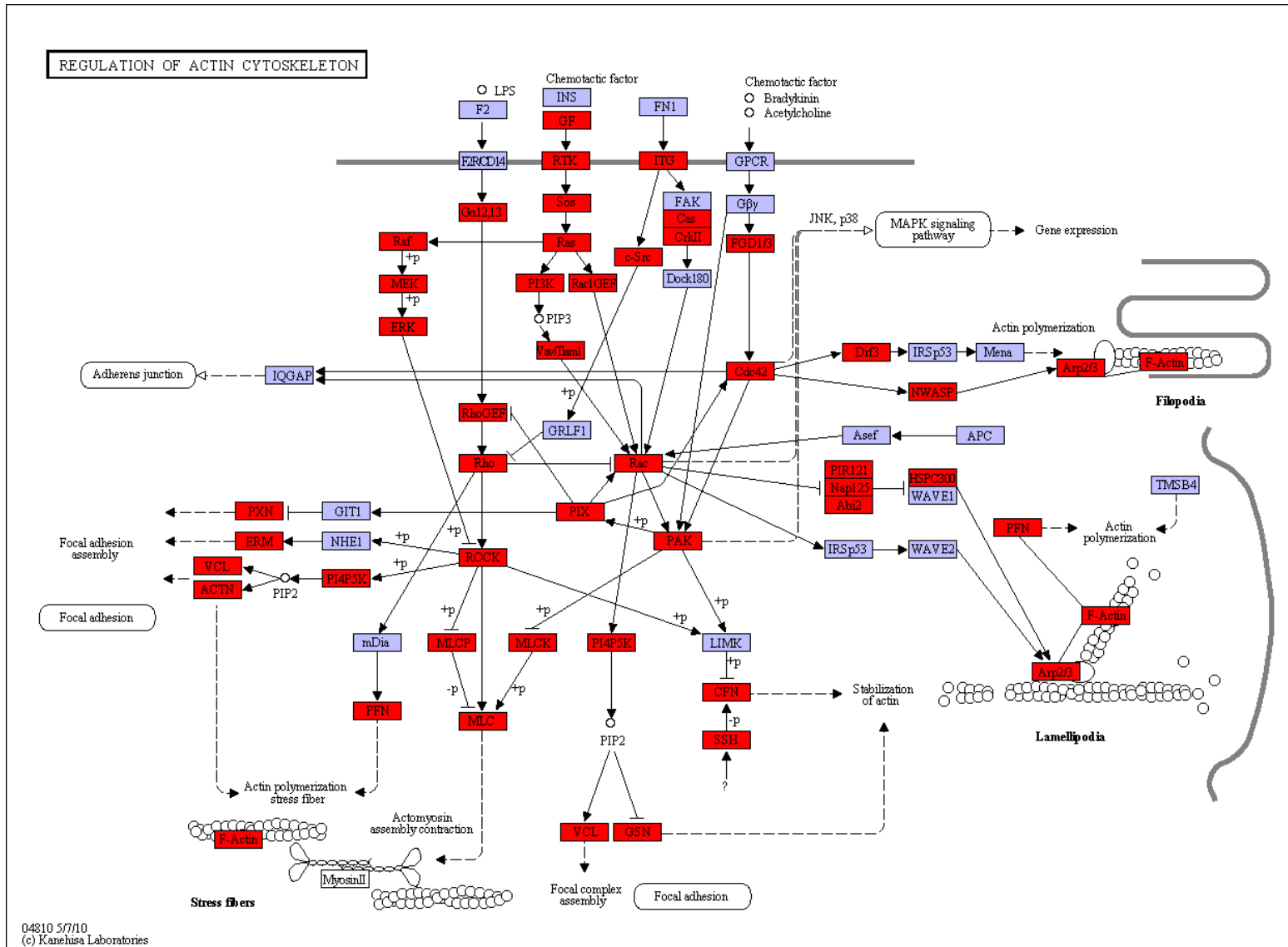

Figure 14: ko04810 Regulation of actin cytoskeleton

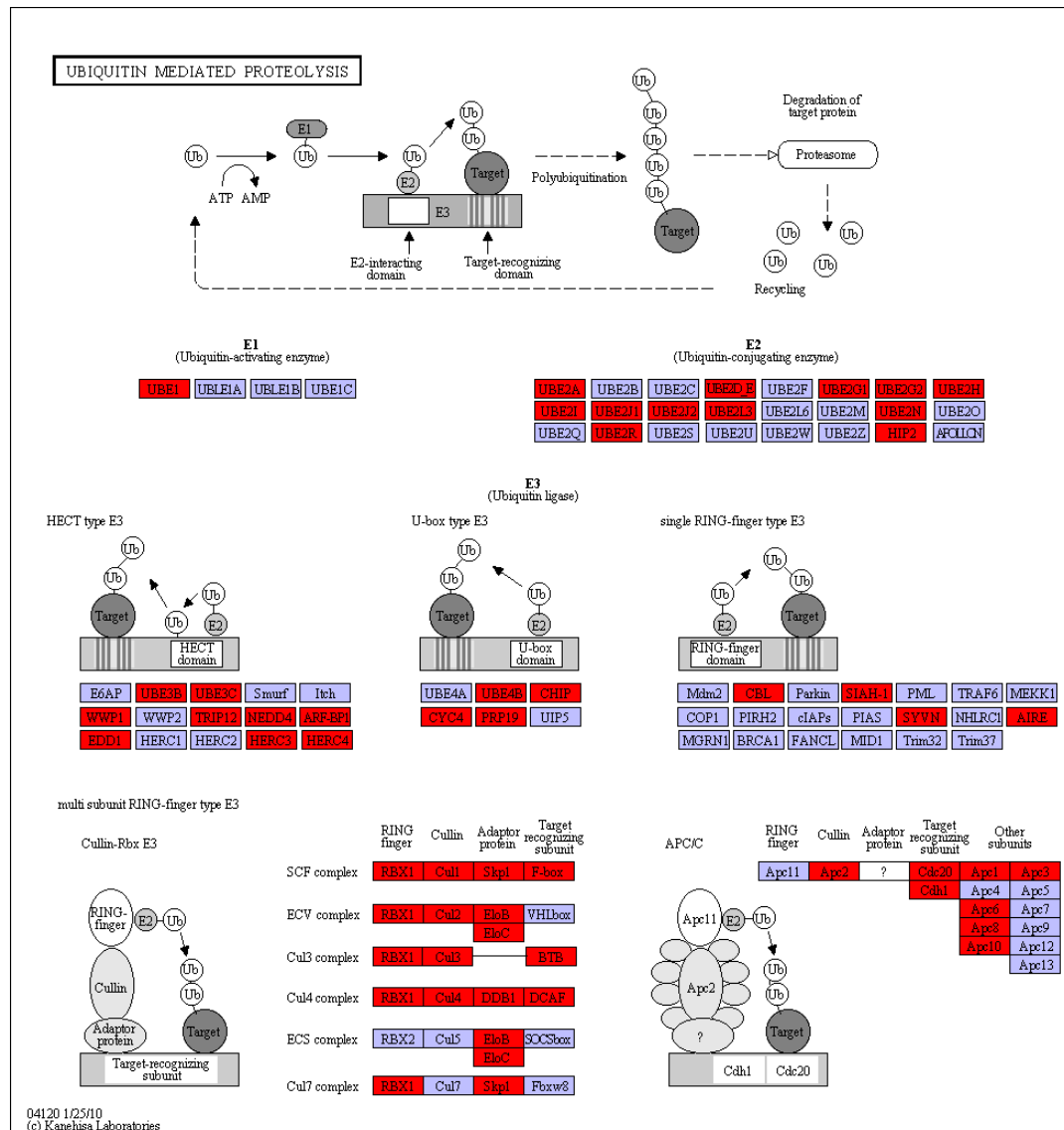

Figure 15: ko04120 Ubiquitin mediated proteolysis



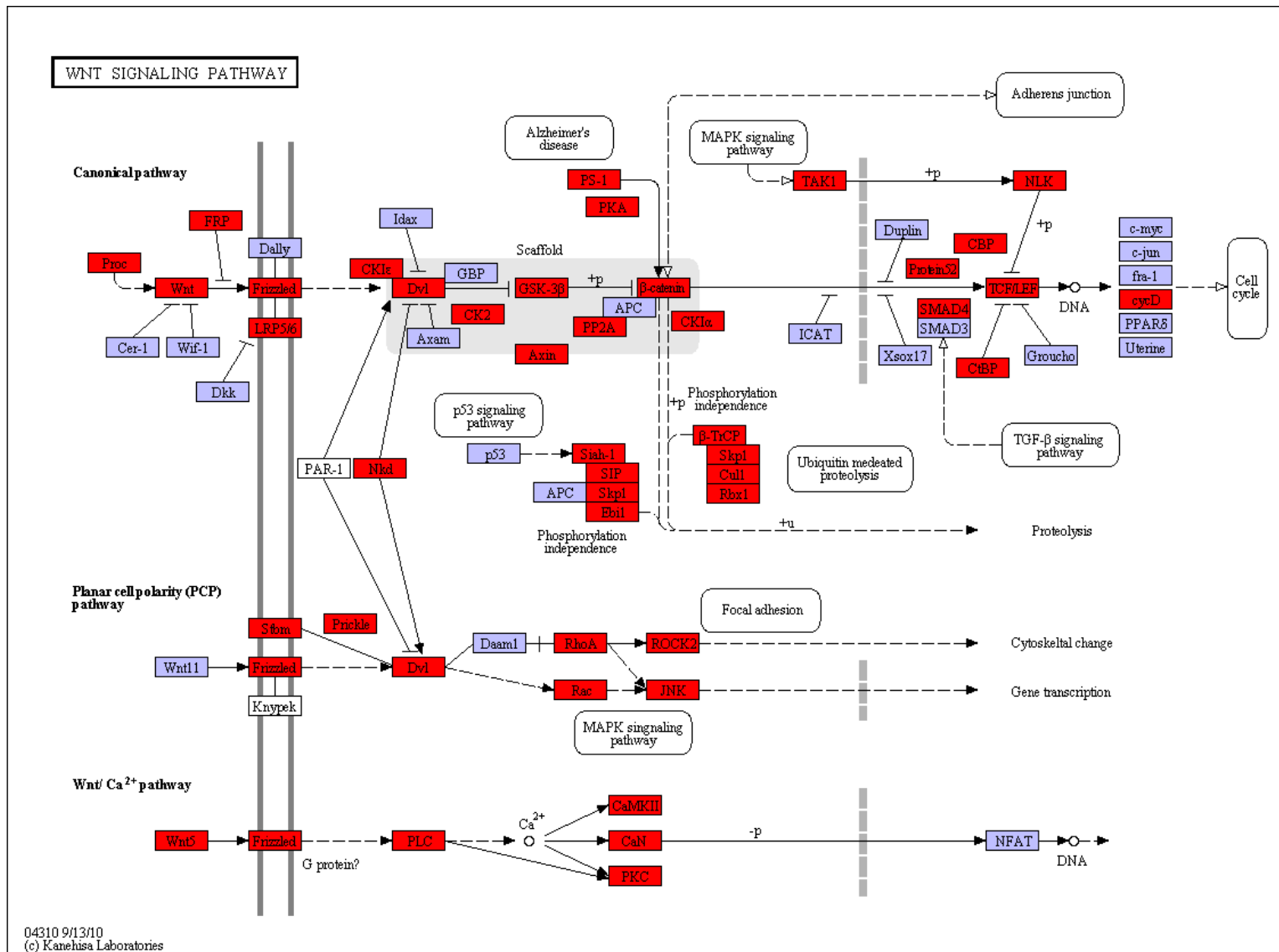

Figure 16: ko04310 Wnt signaling pathway

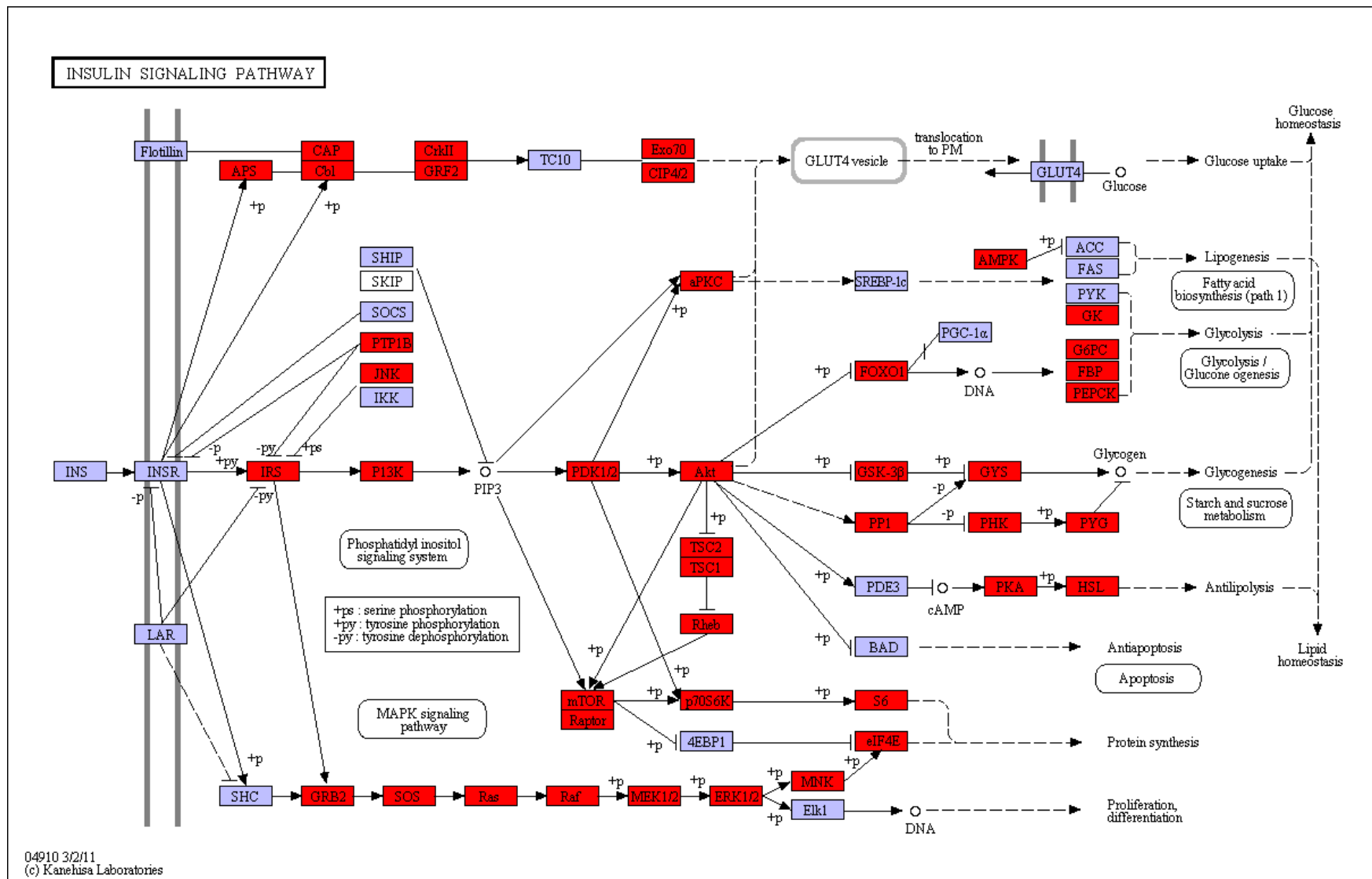

Figure 17: ko04910 Insulin signaling pathway

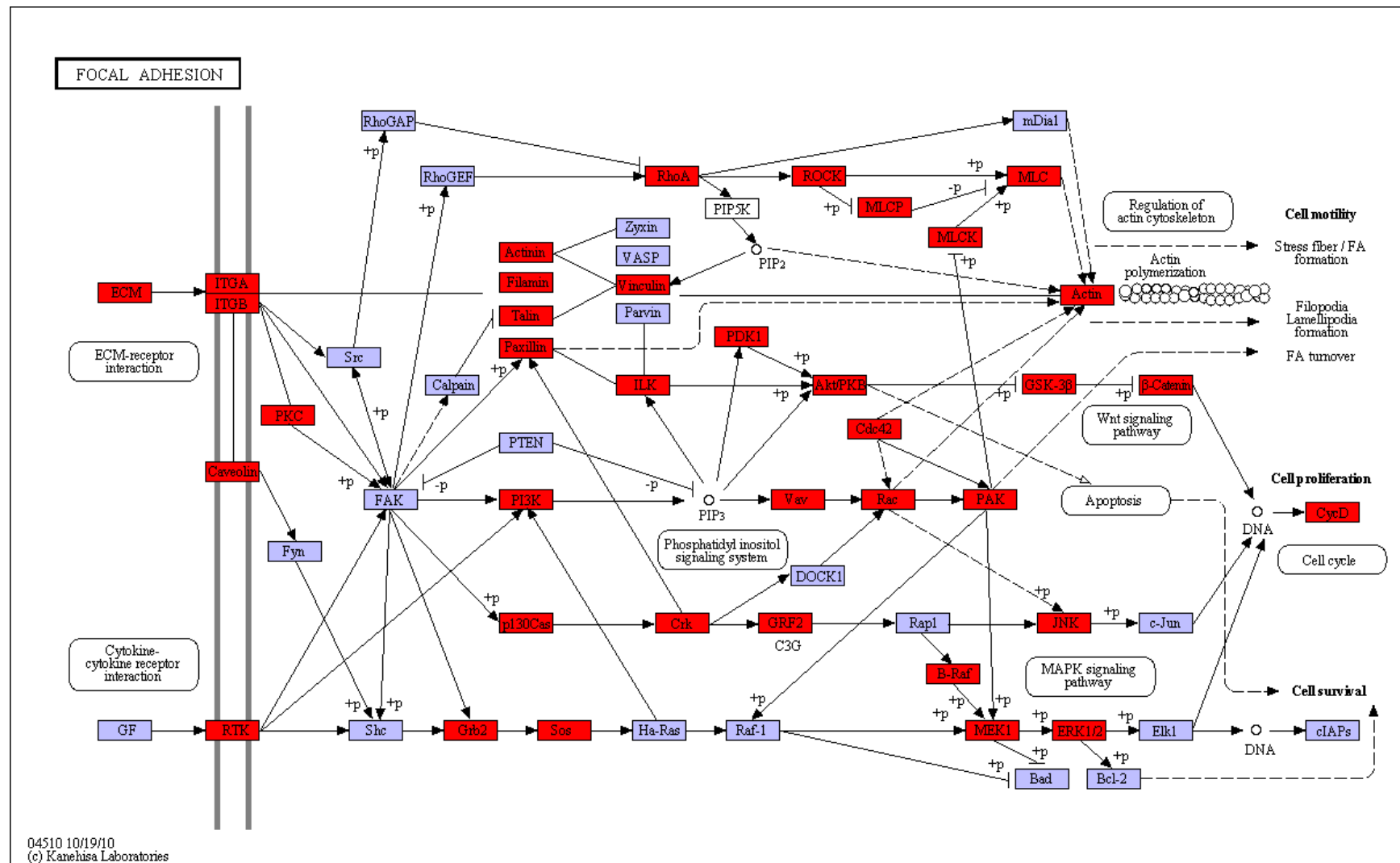

Figure 18: ko04510 Focal adhesion

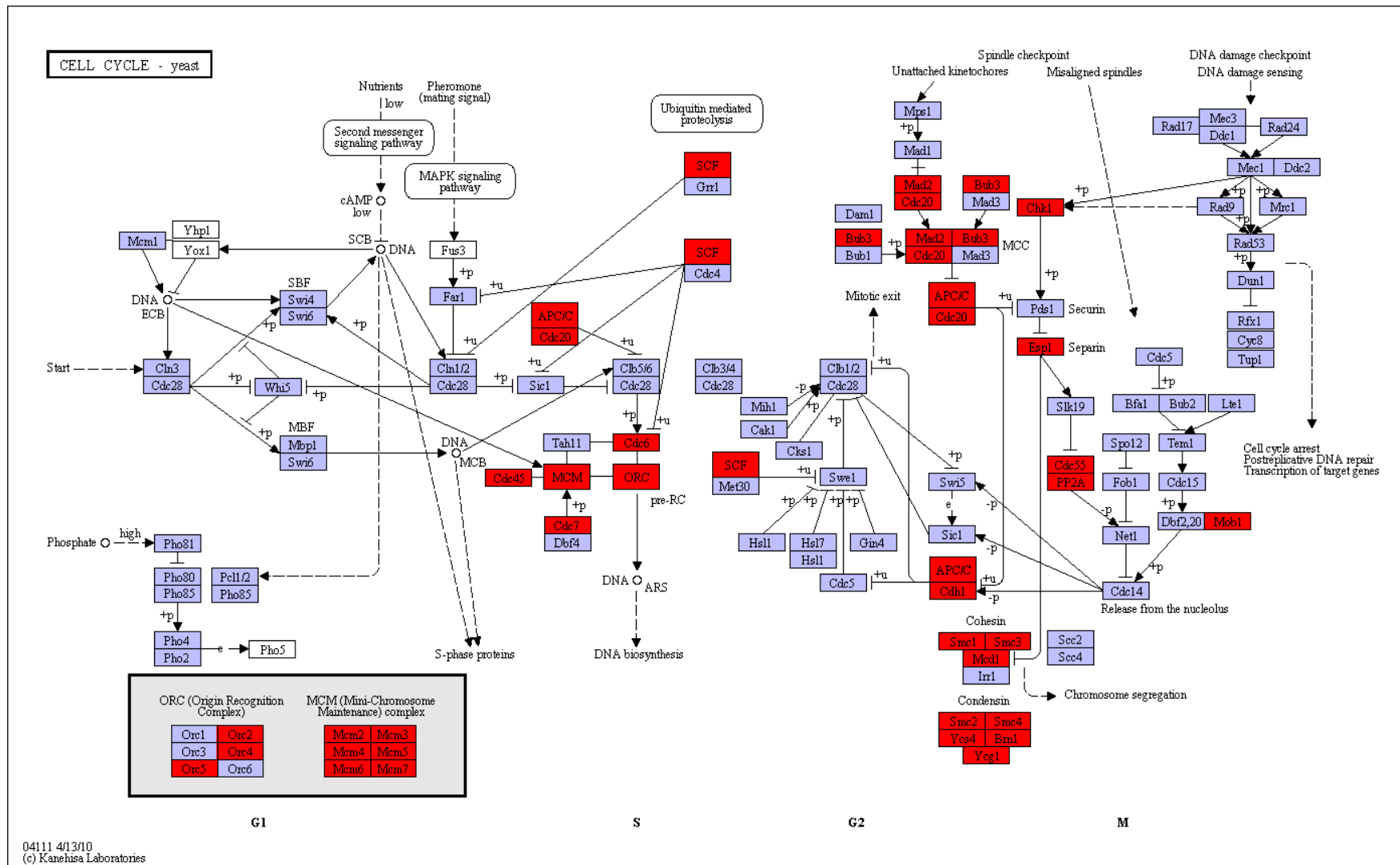

Figure 19: ko04111 Cell cycle - yeast



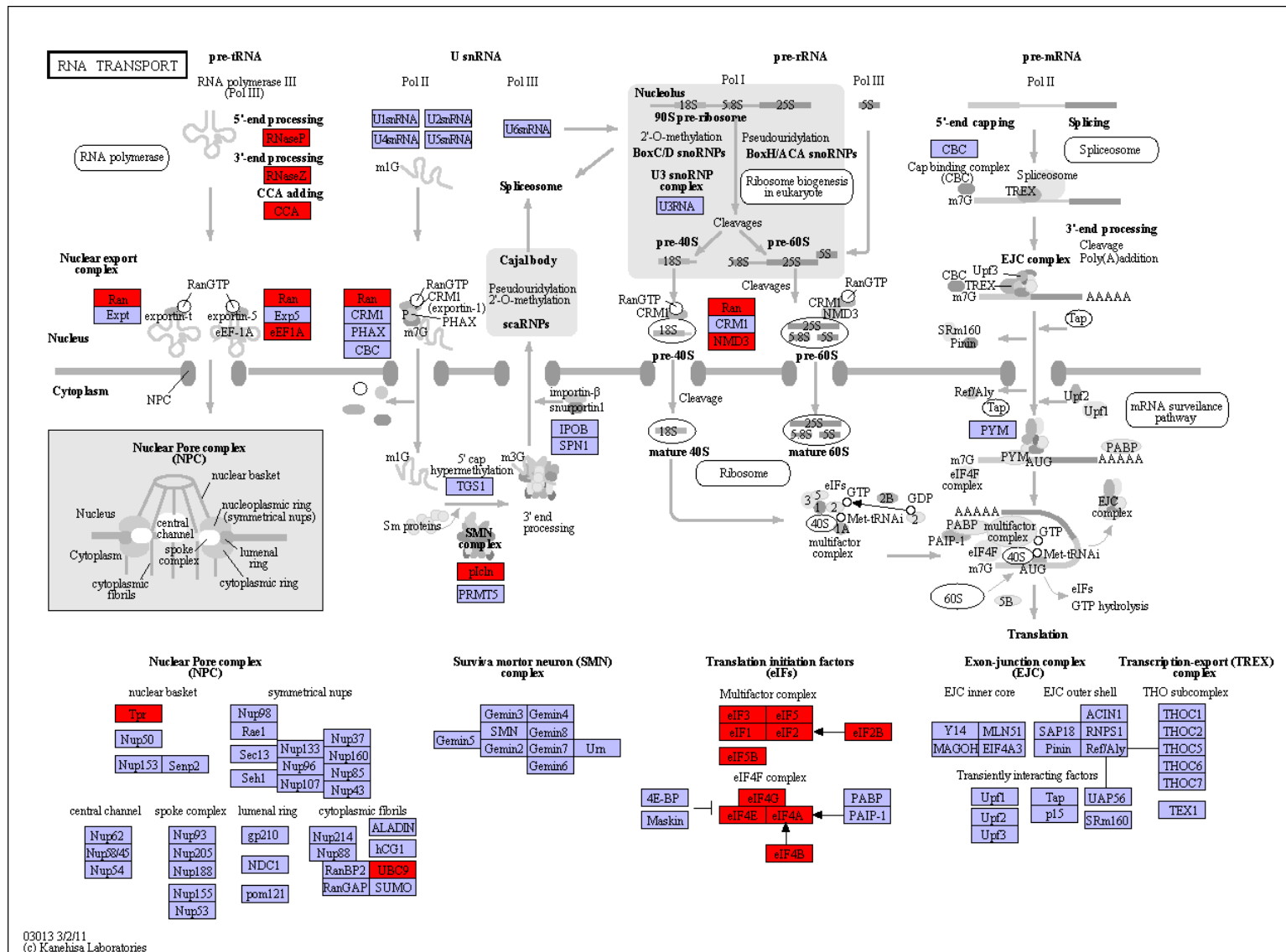

Figure 21: ko03013 RNA transport

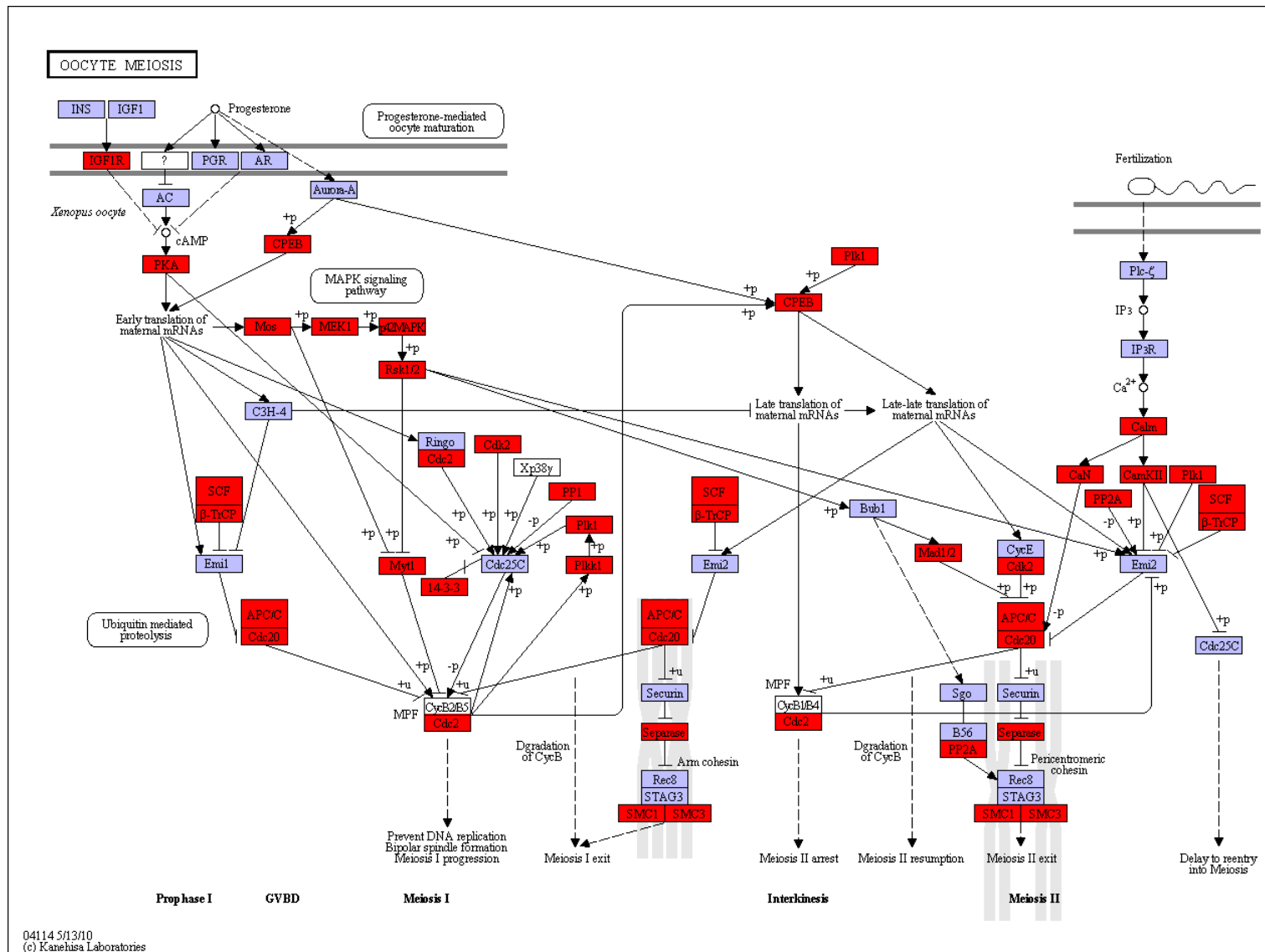

Figure 22: ko04114 Oocyte meiosis

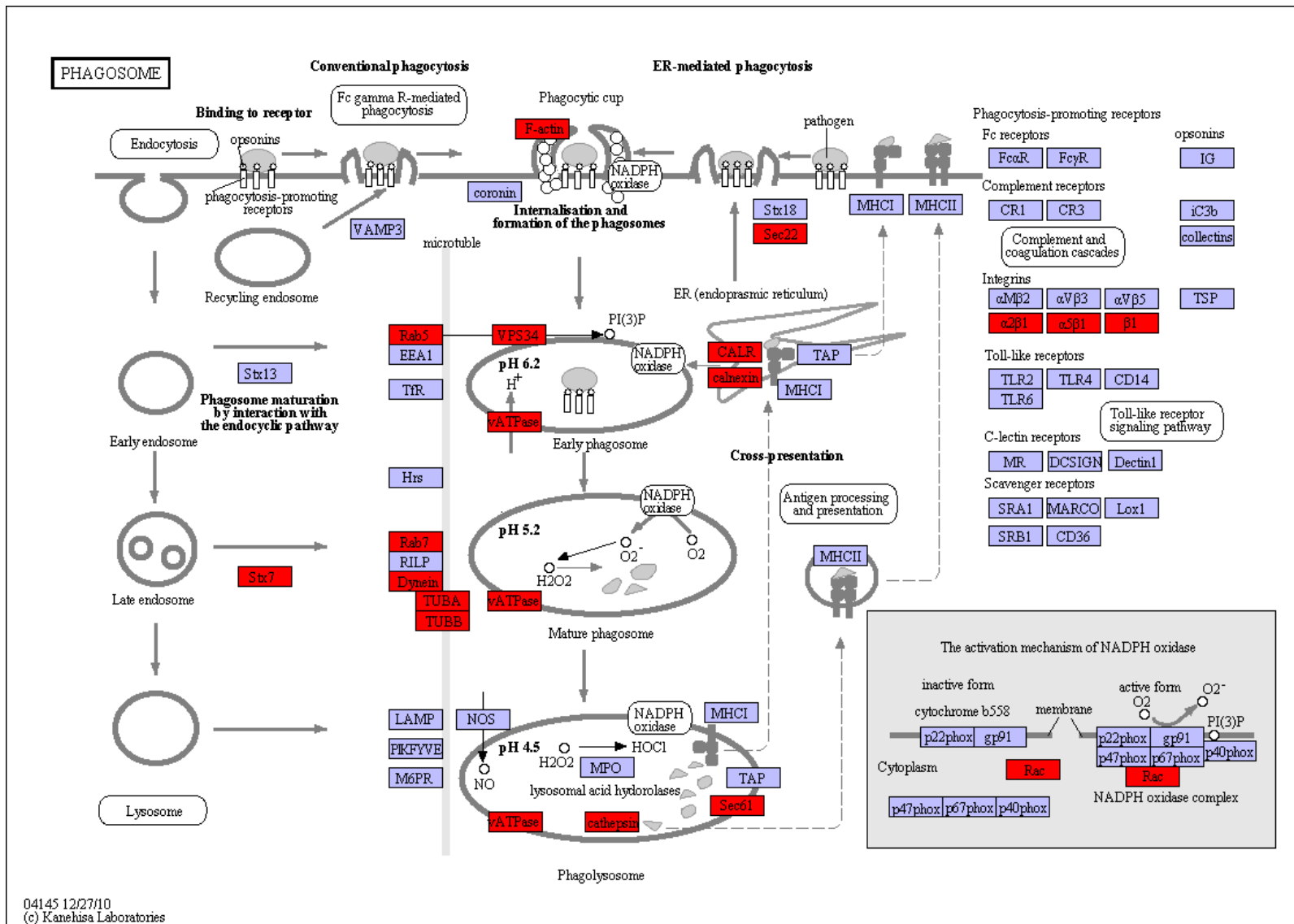

Figure 23: ko04145 Phagosome





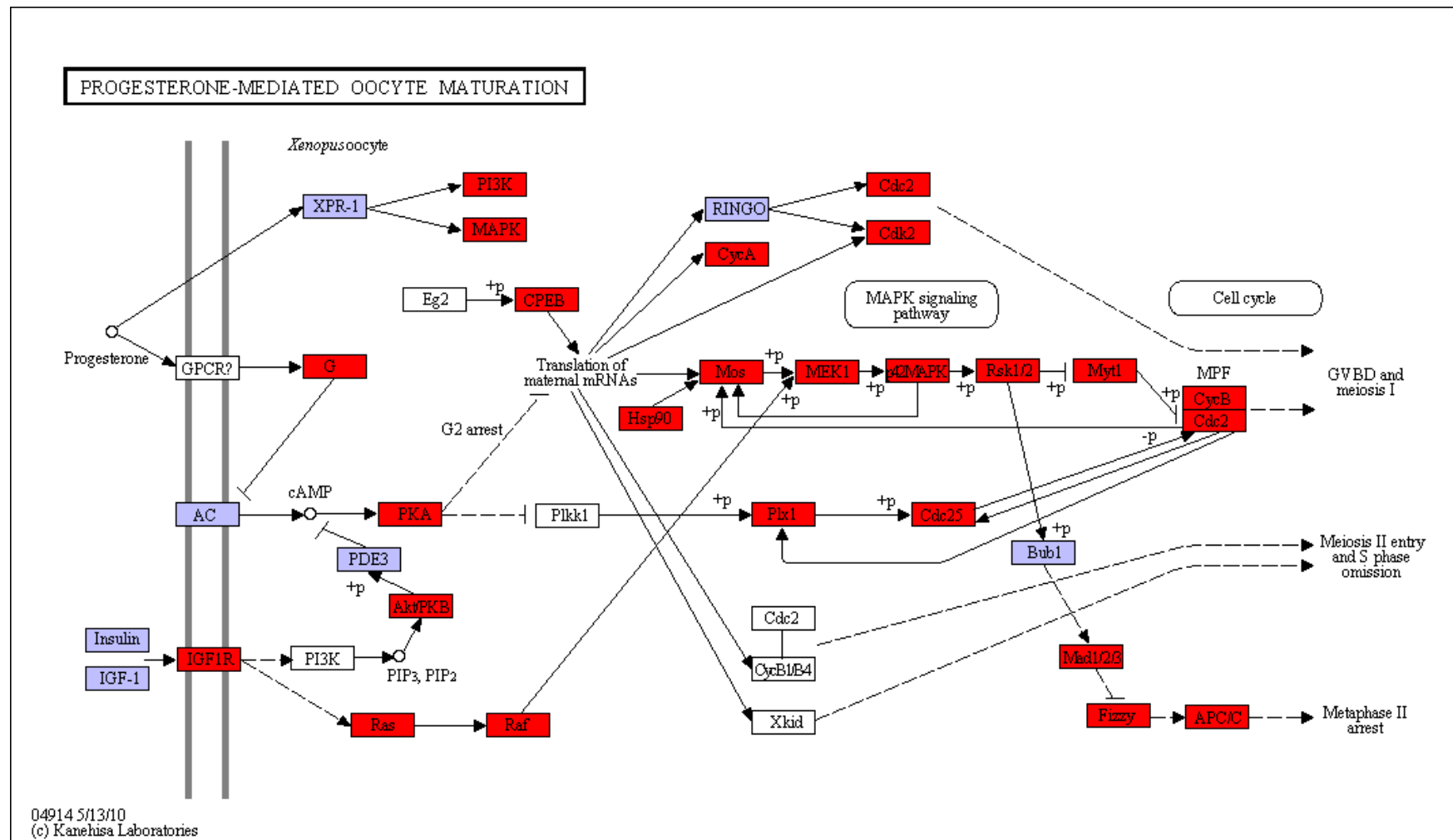

Figure 25: ko04914 Progesterone-mediated oocyte maturation

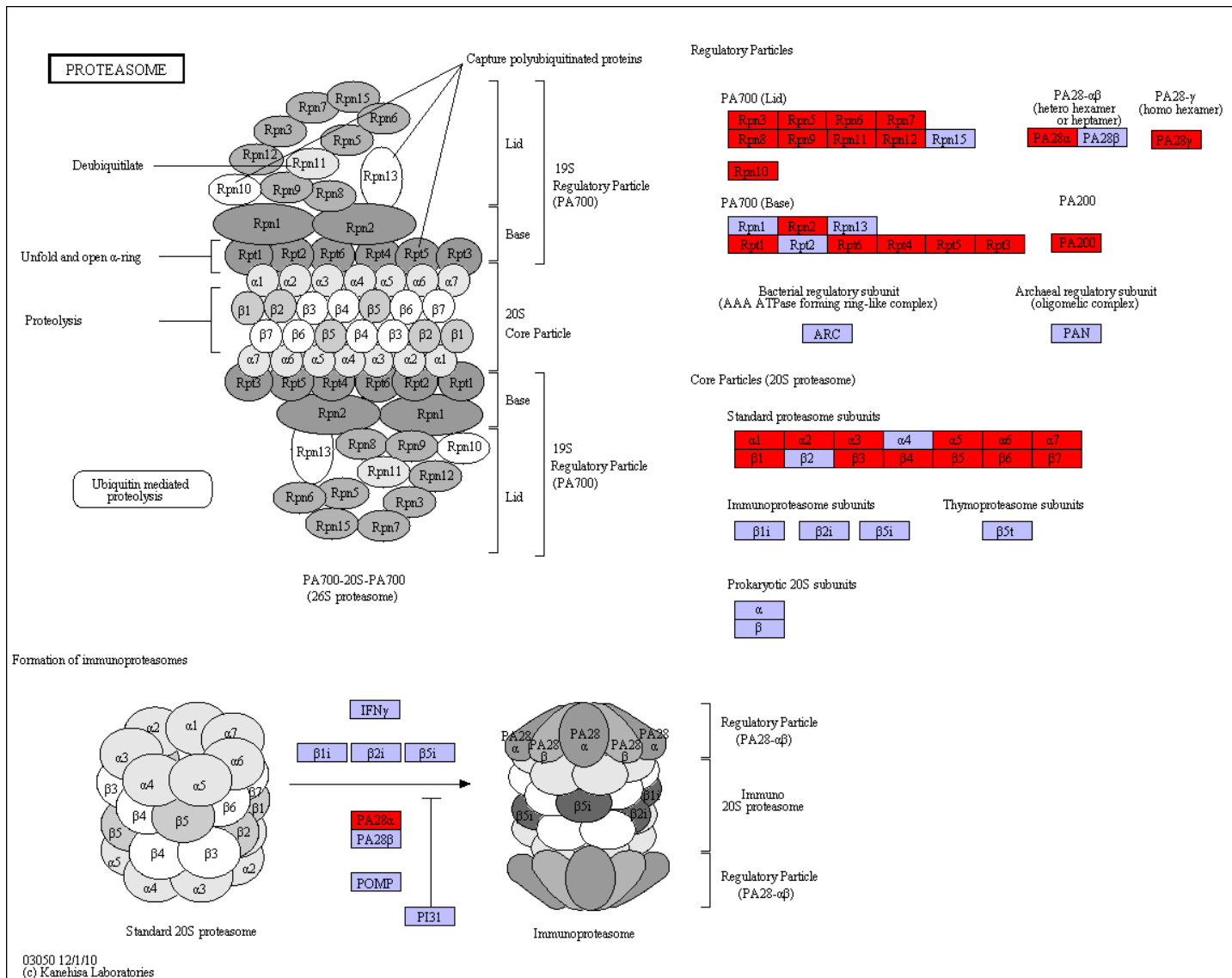

Figure 26: ko03050 Proteasome

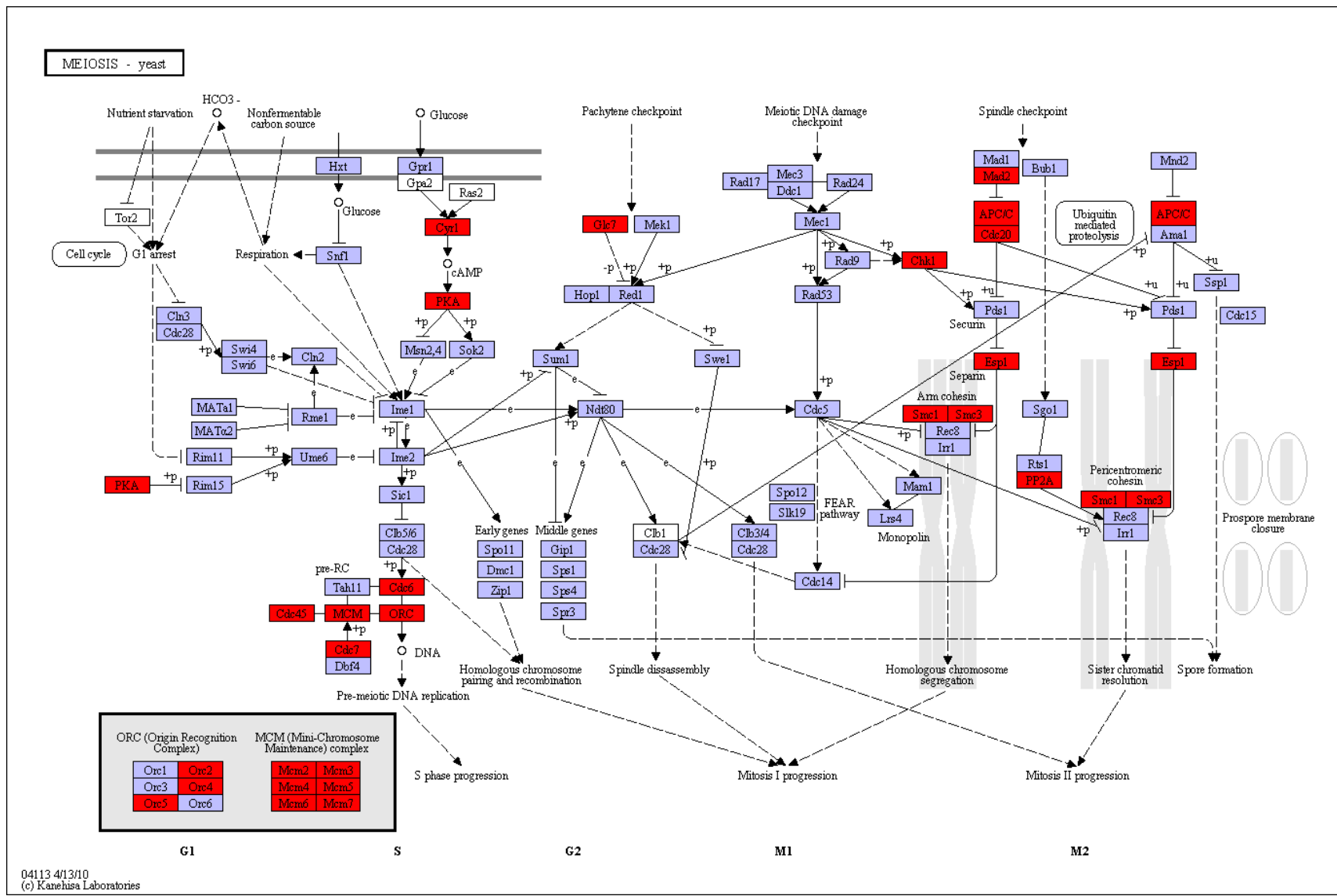

Figure 27: ko04113 Meiosis - yeast

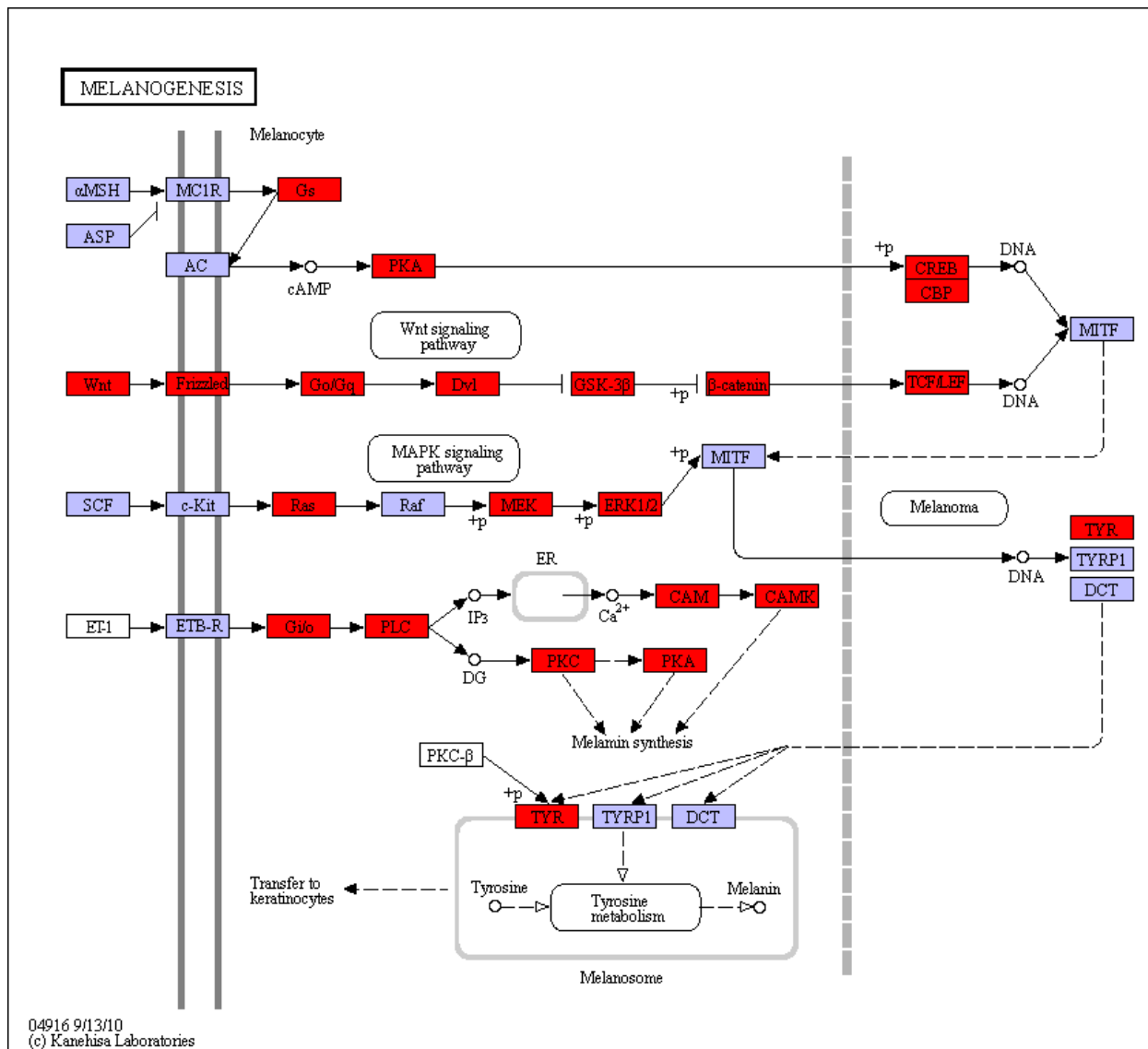

Figure 28: ko04916 Melanogenesis



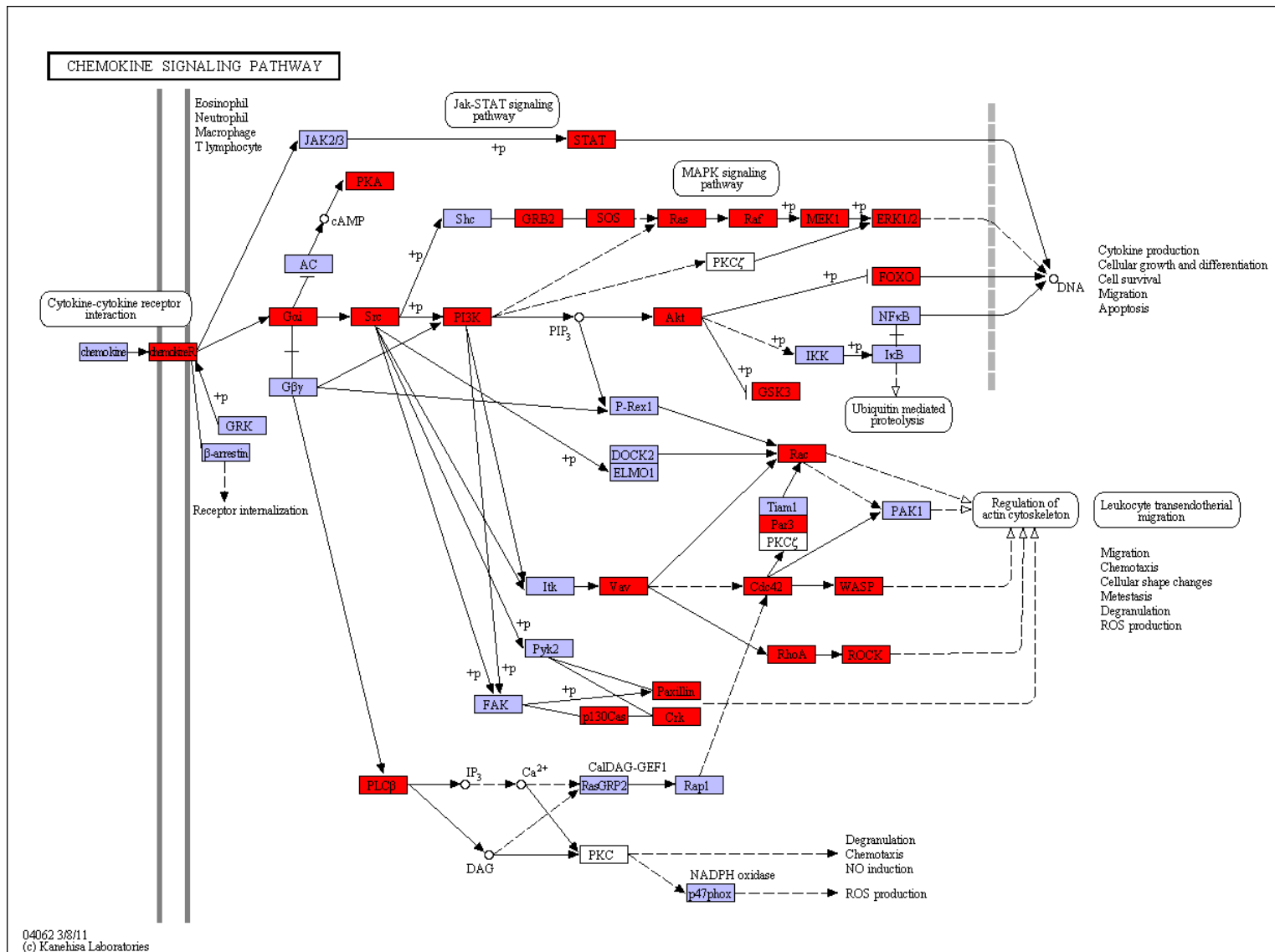

Figure 30: ko04062 Chemokine signaling pathway







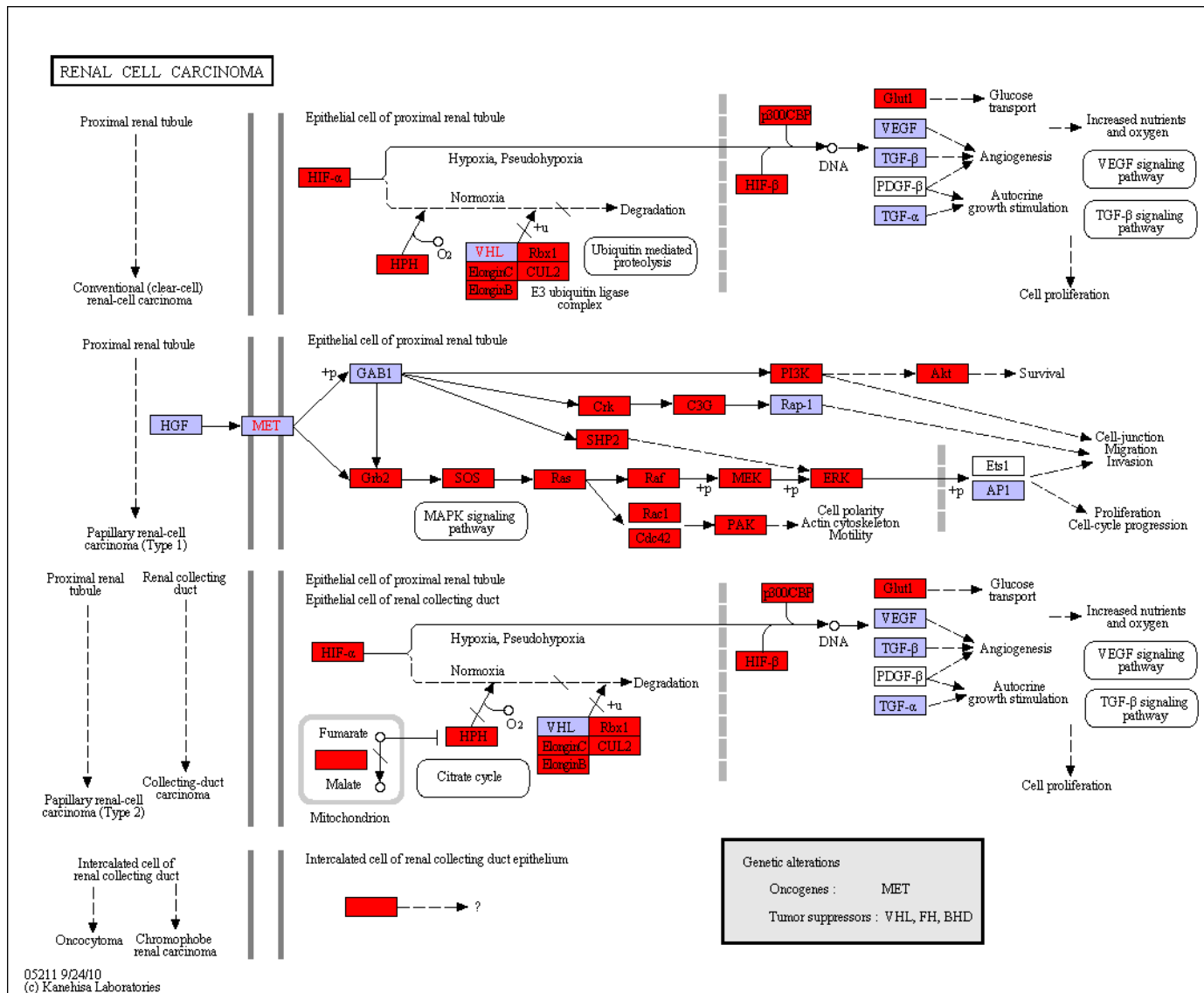

Figure 33: ko05211 Renal cell carcinoma

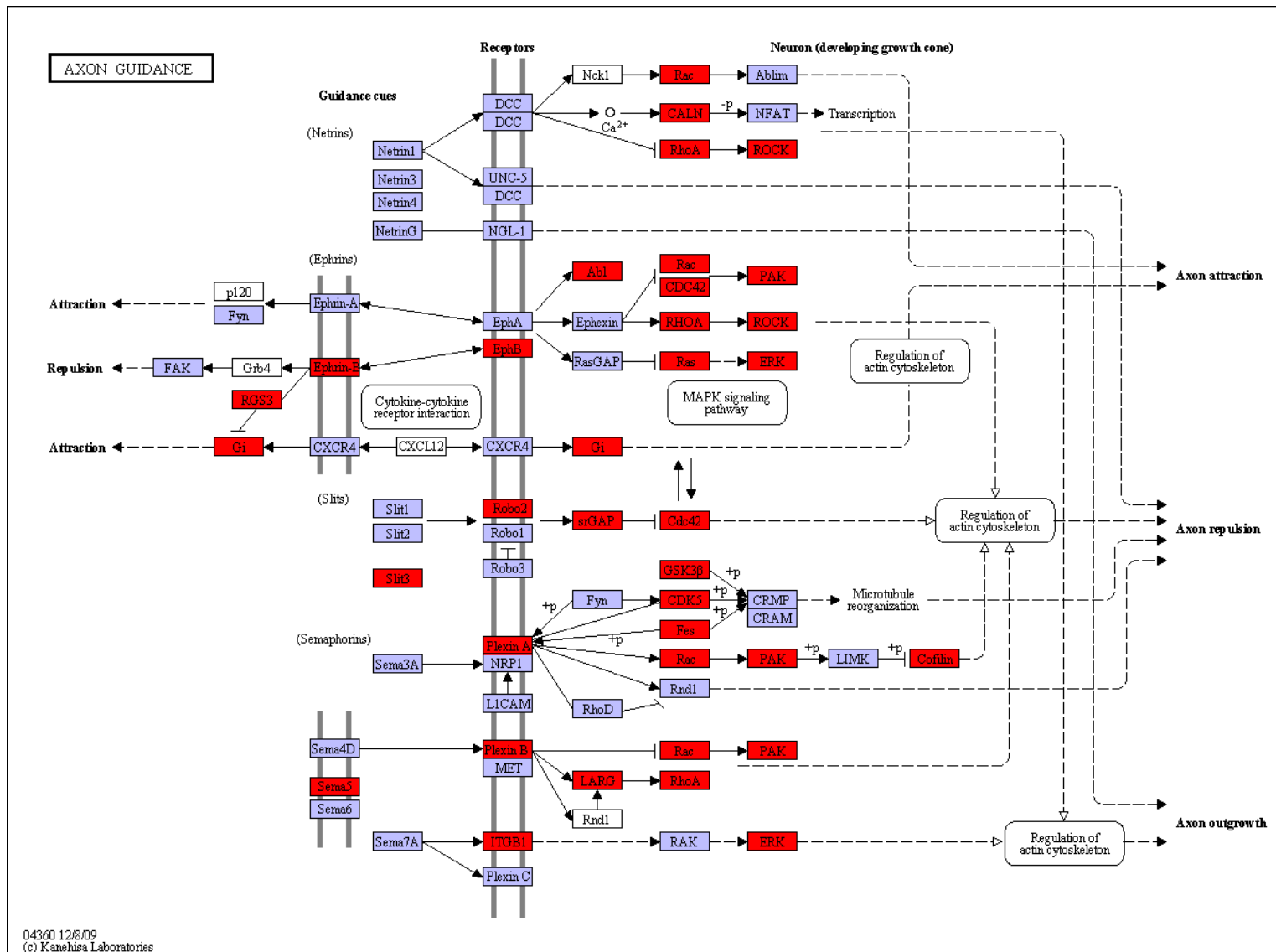

Figure 34: ko04360 Axon guidance

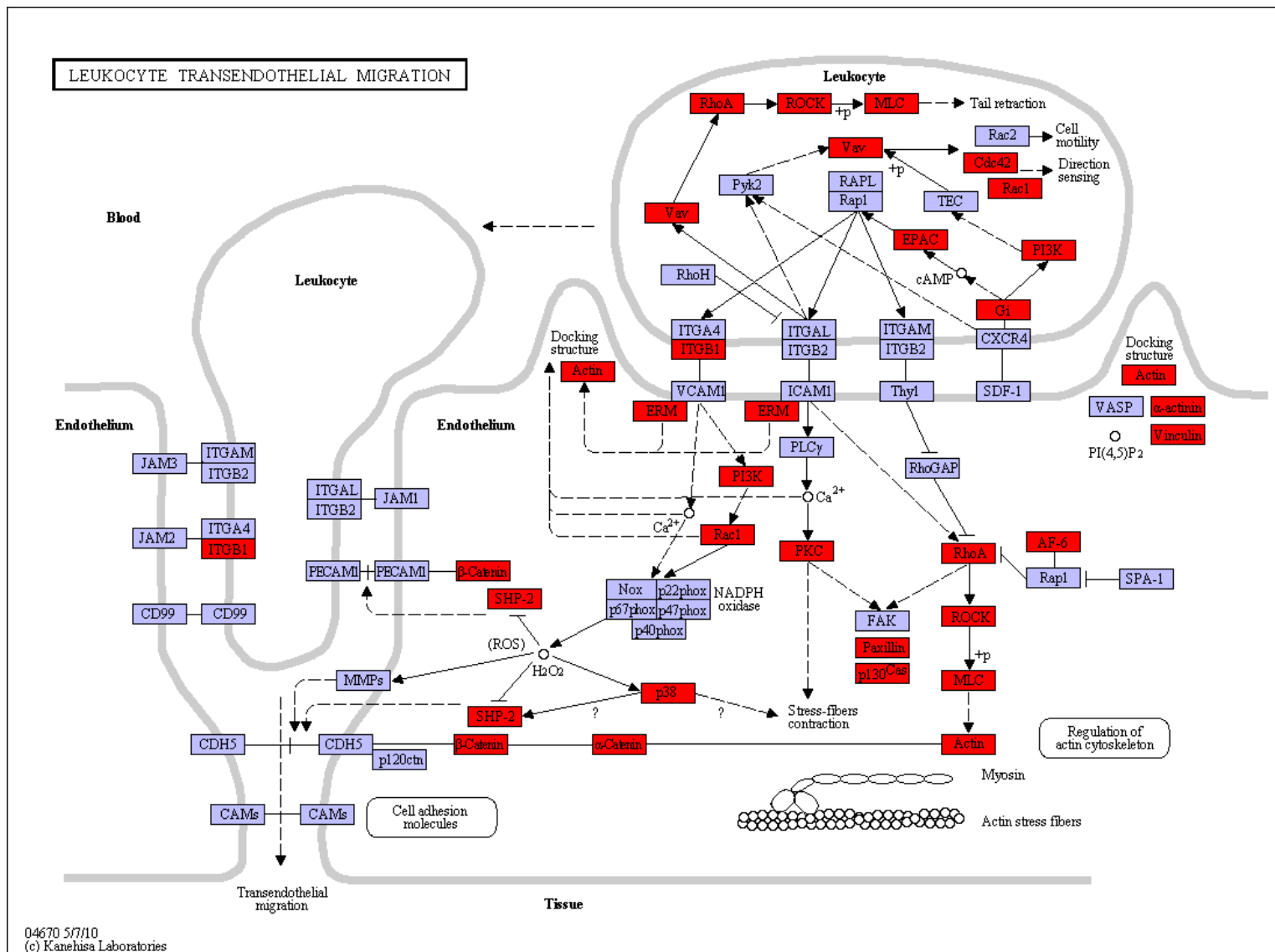

Figure 35: ko04670 Leukocyte transendothelial migration

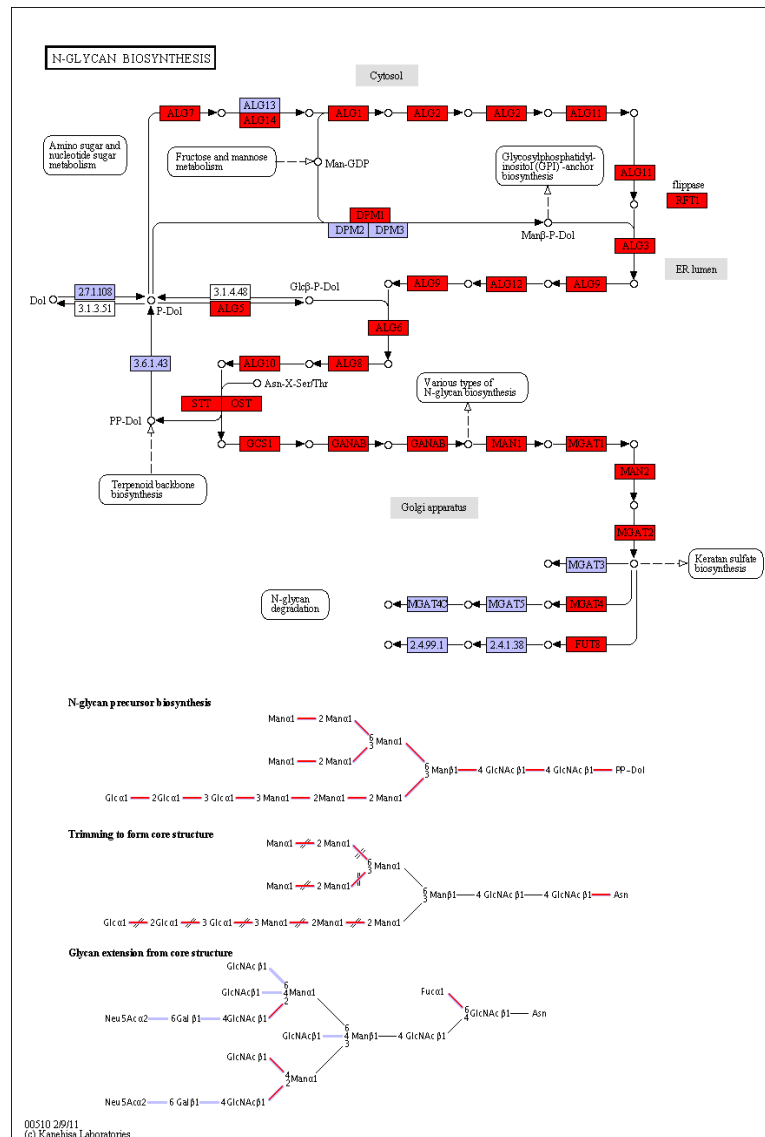

Figure 36: ko00510 N-Glycan biosynthesis

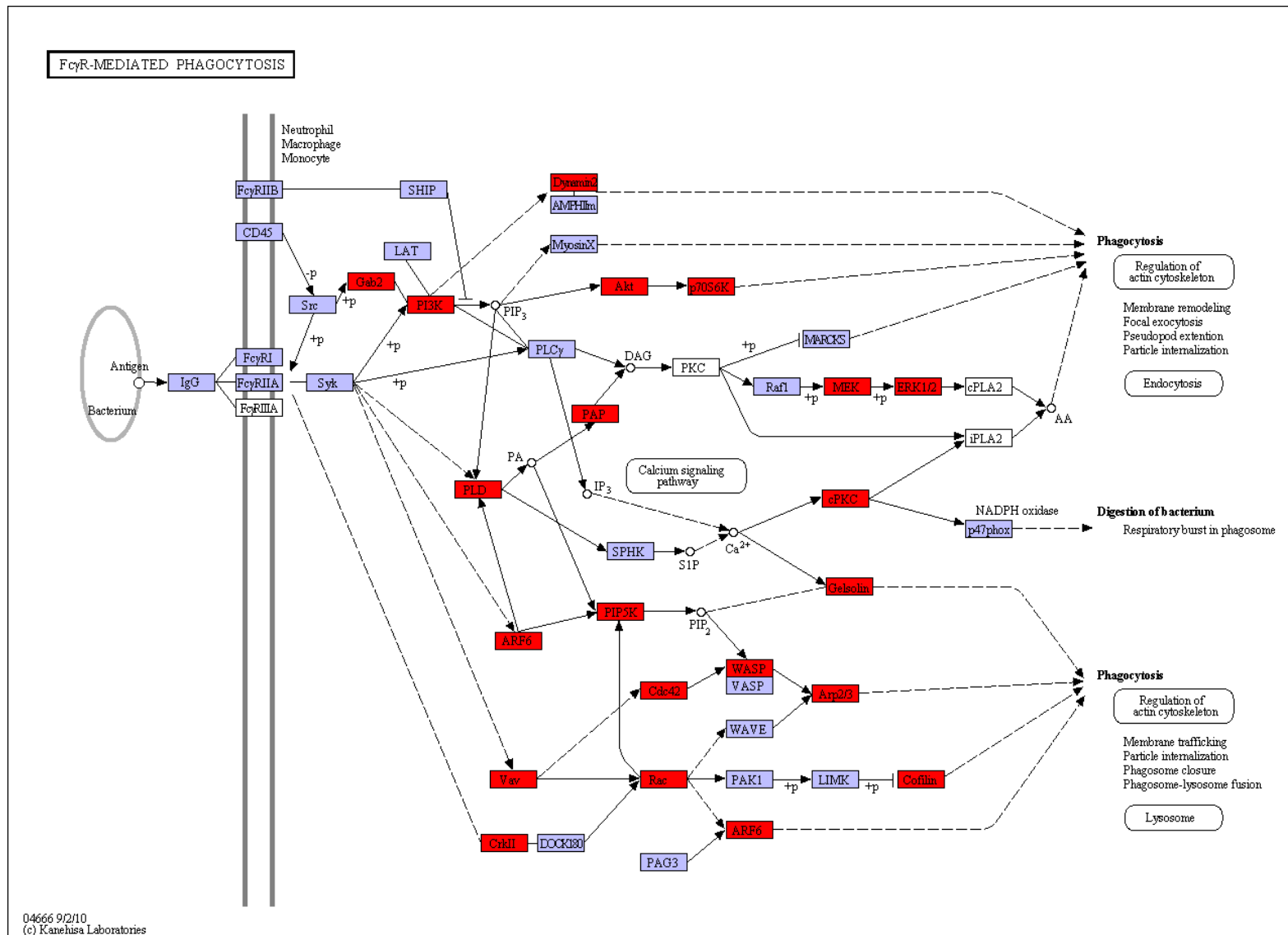

Figure 37: ko04666 Fc gamma R-mediated phagocytosis

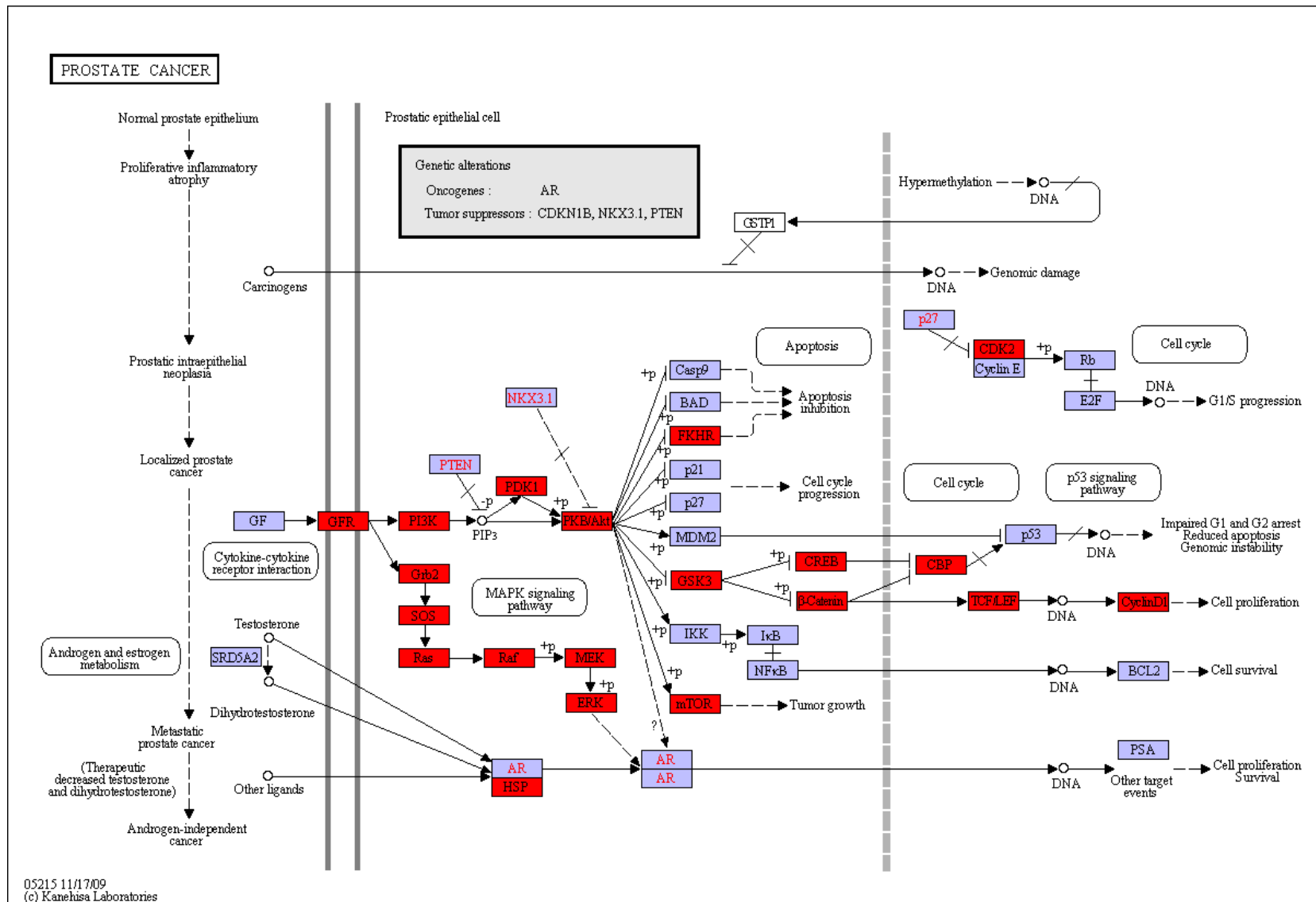

Figure 38: ko05215 Prostate cancer

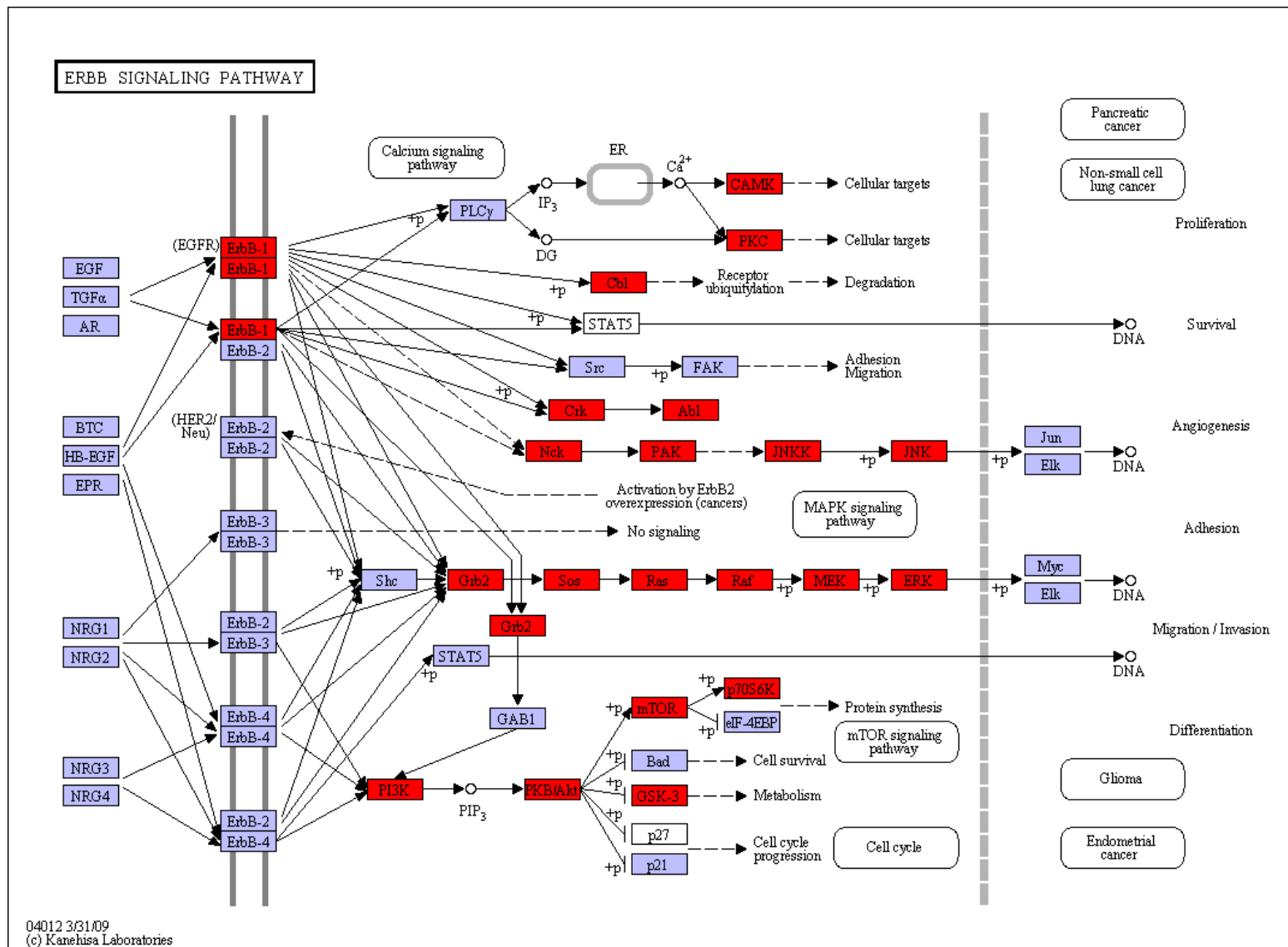

Figure 39: ko04012 ErbB signaling pathway



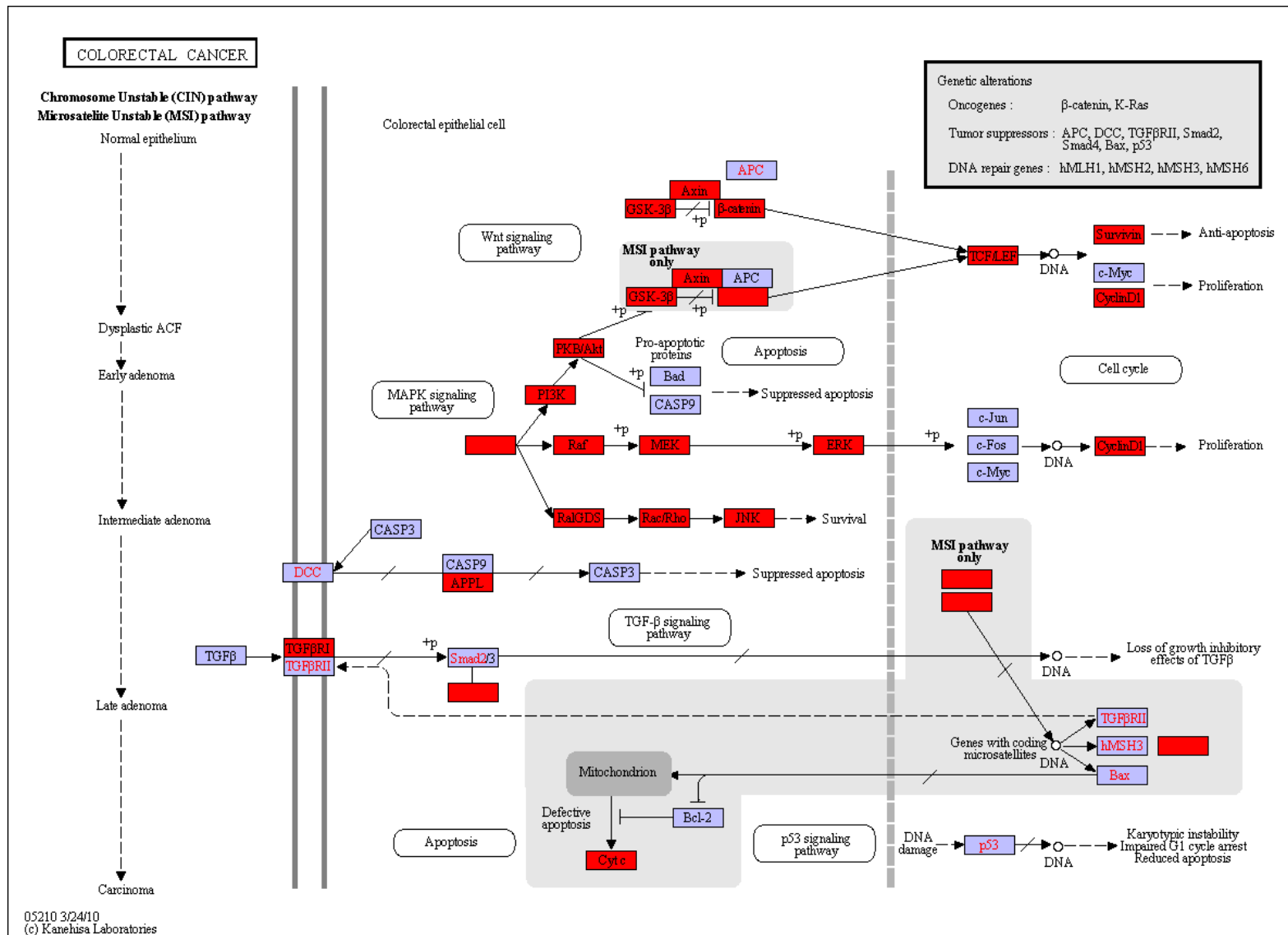

Figure 40: ko05210 Colorectal cancer

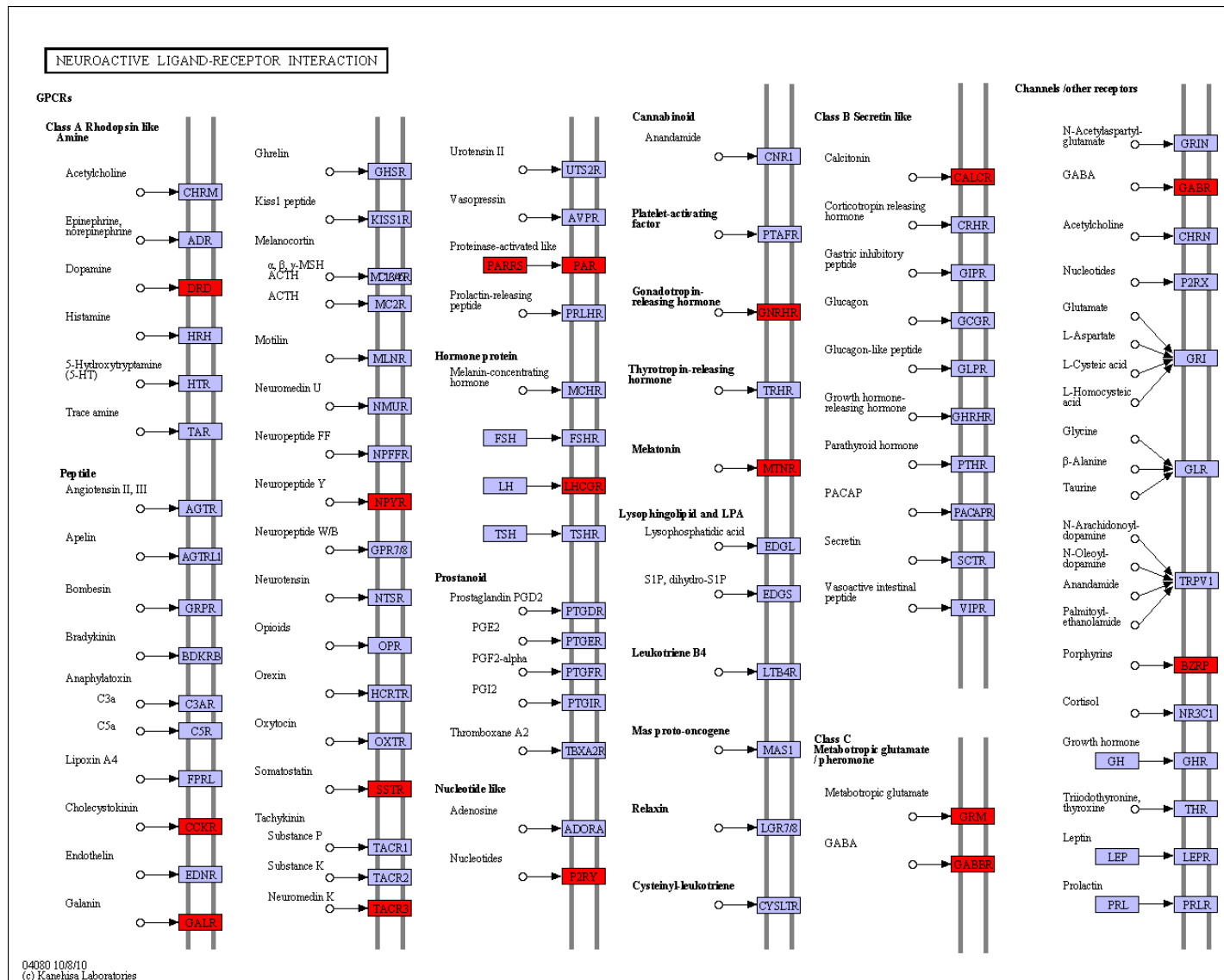

Figure 41: ko04080 Neuroactive ligand-receptor interaction



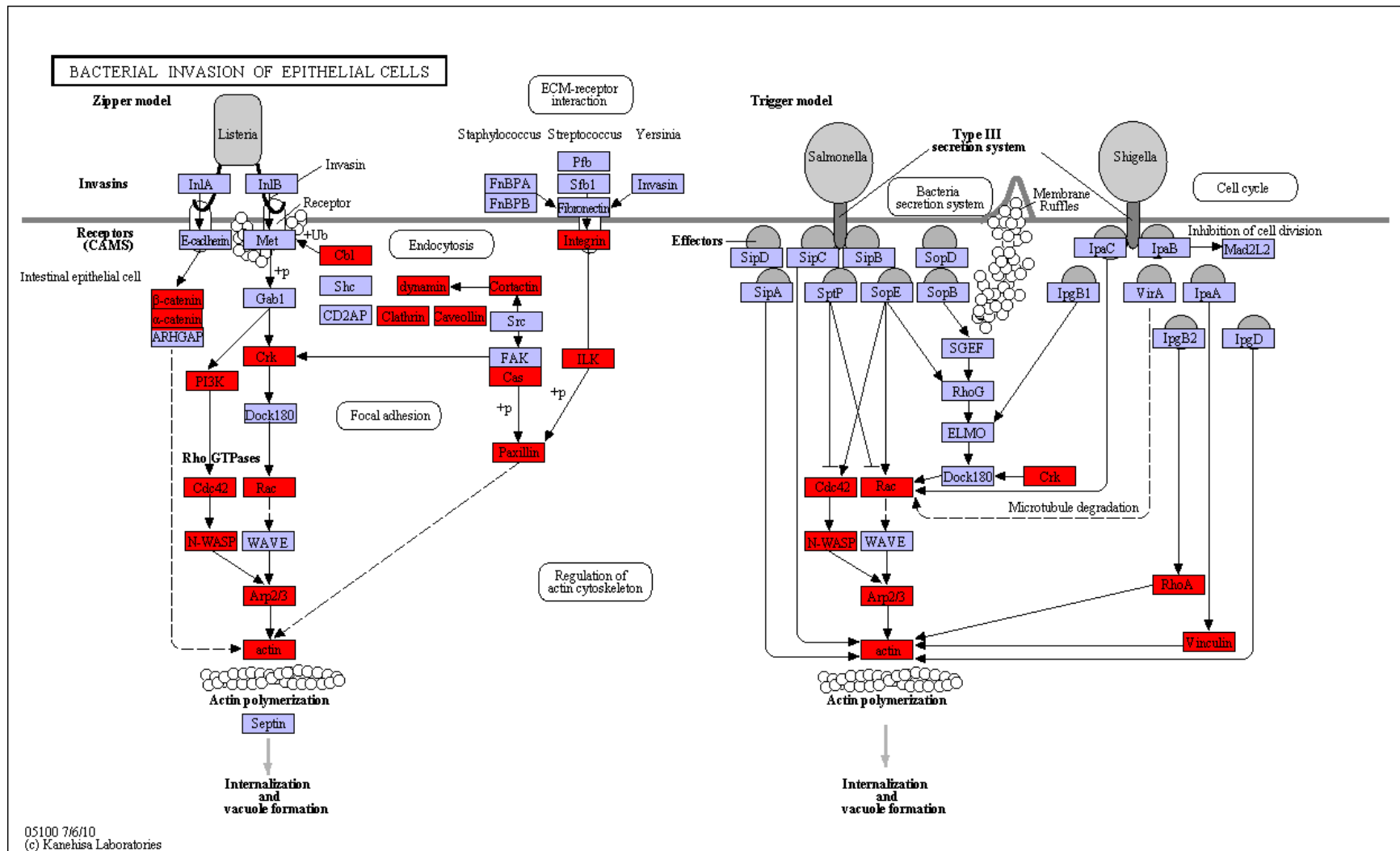

Figure 43: ko05100 Bacterial invasion of epithelial cells



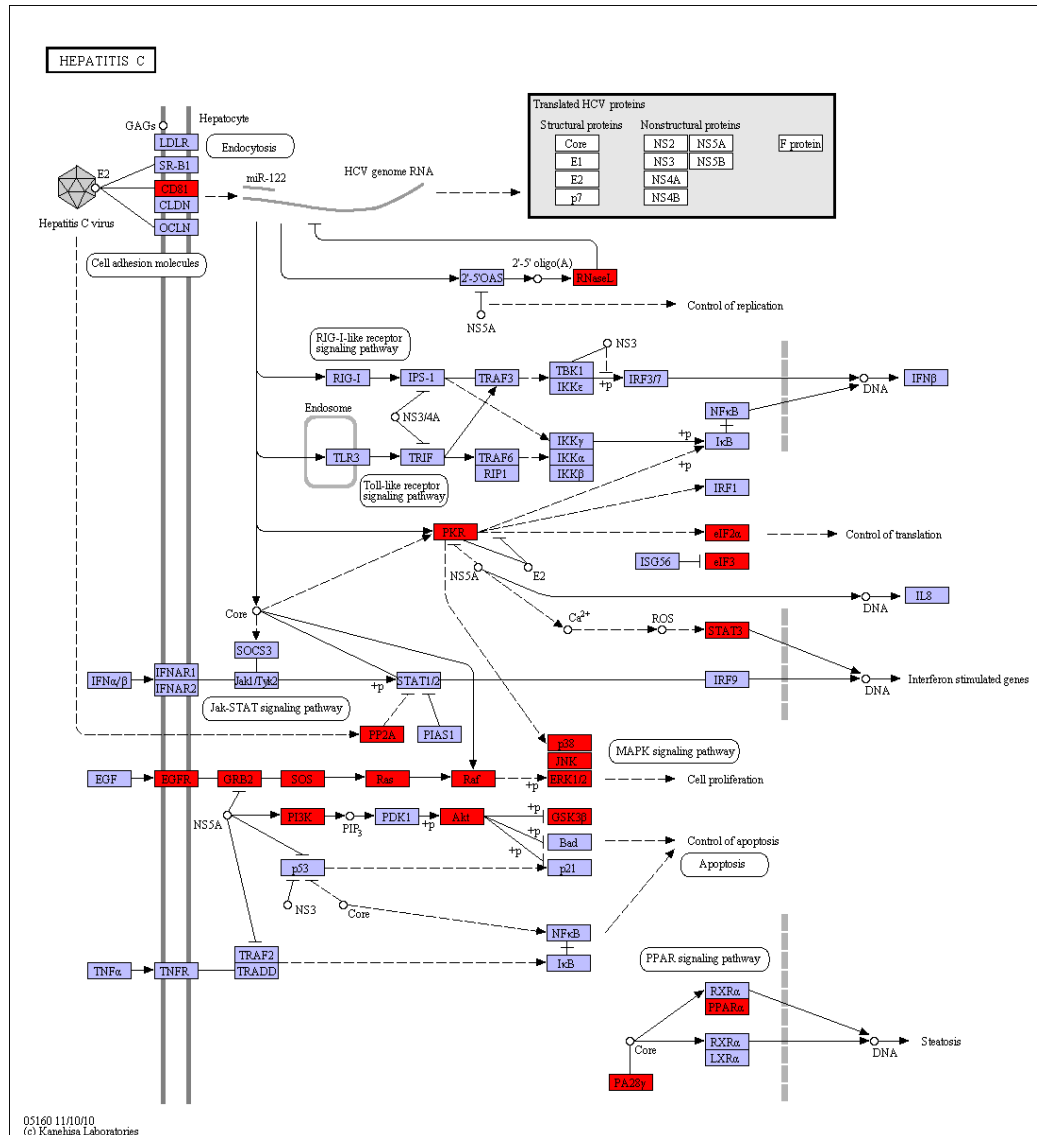

Figure 45: ko05160 Hepatitis C

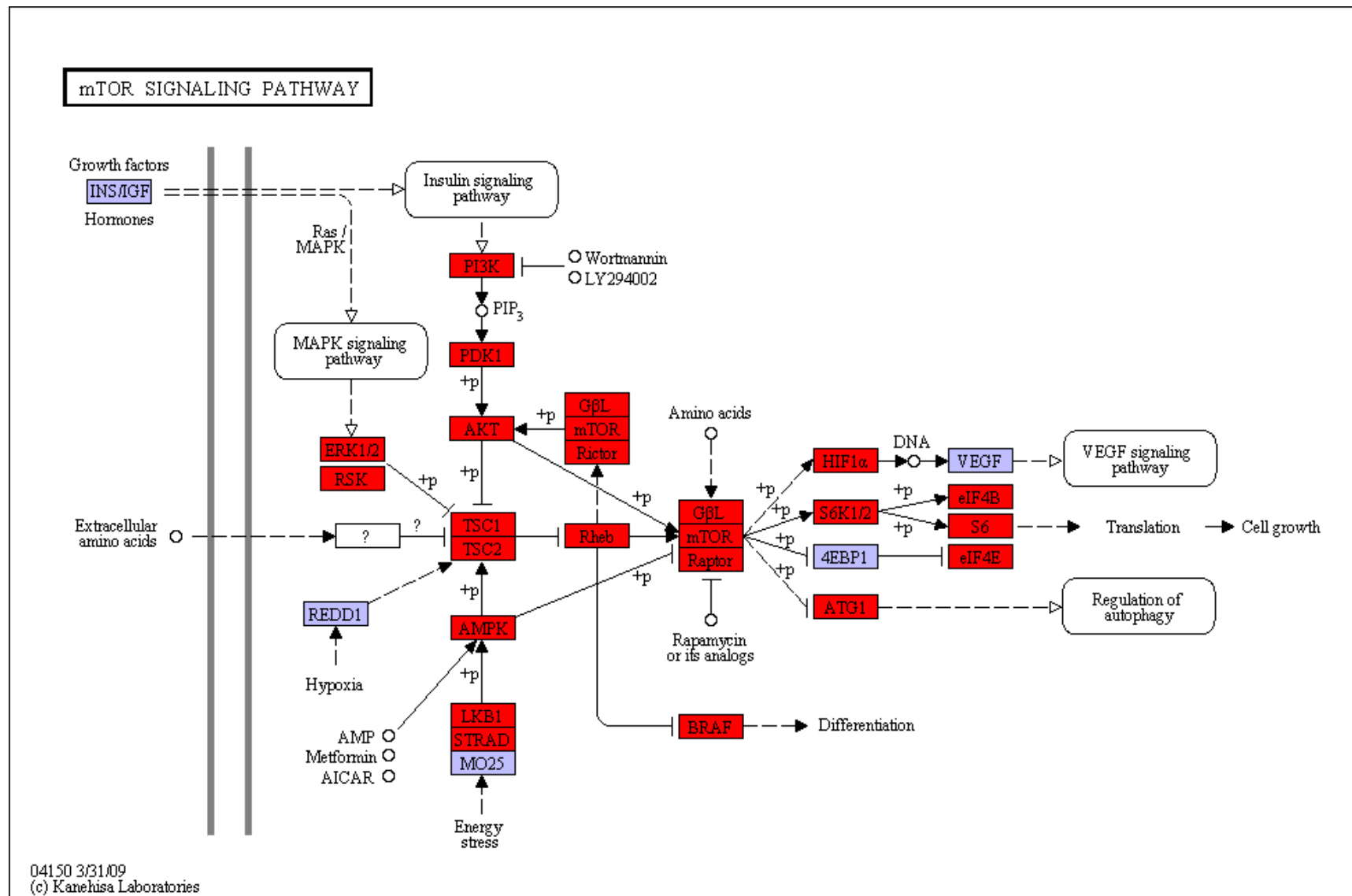

Figure 46: ko04150 mTOR signaling pathway

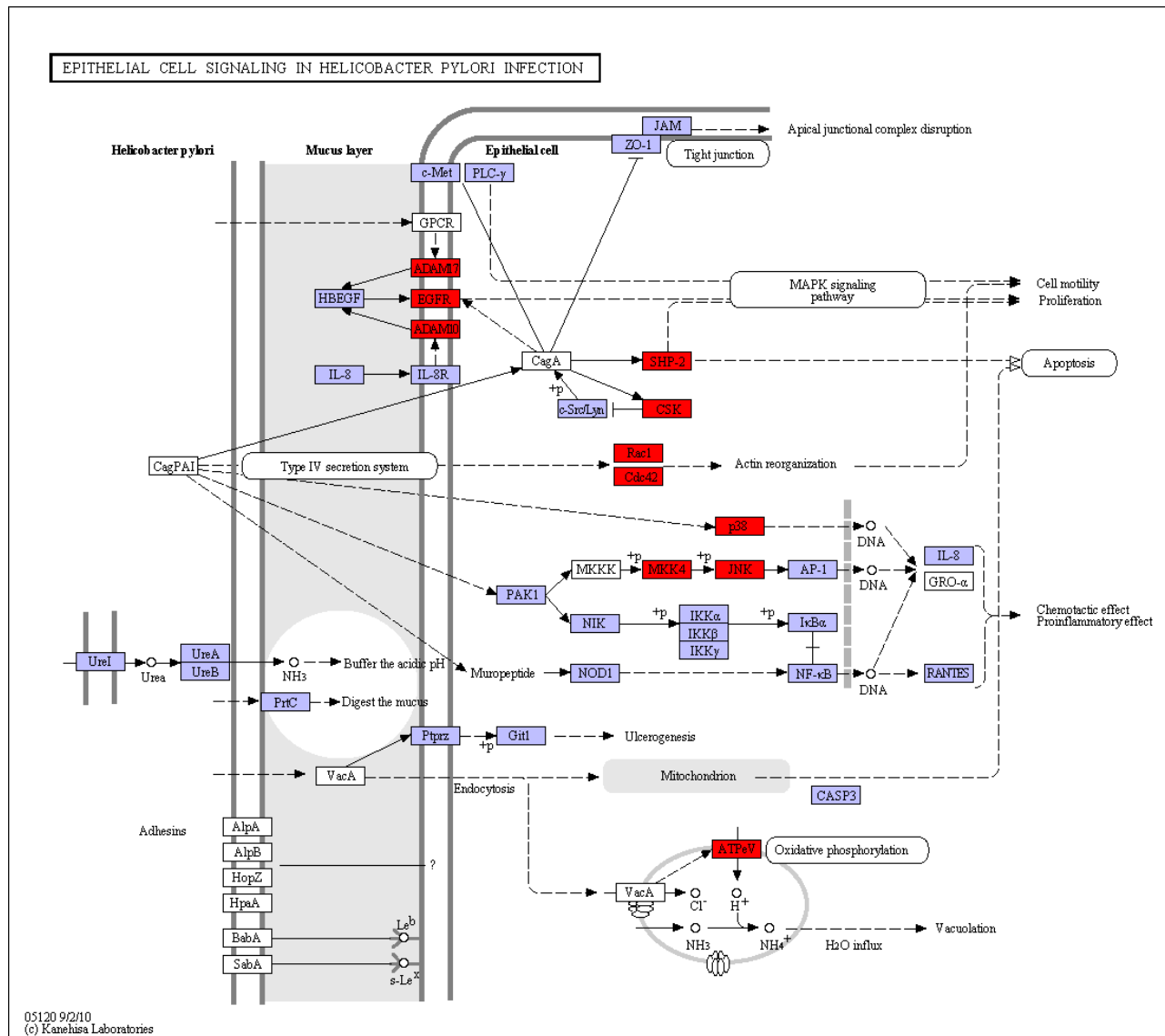

Figure 47: ko05120 Epithelial cell signaling in *Helicobacter pylori* infection



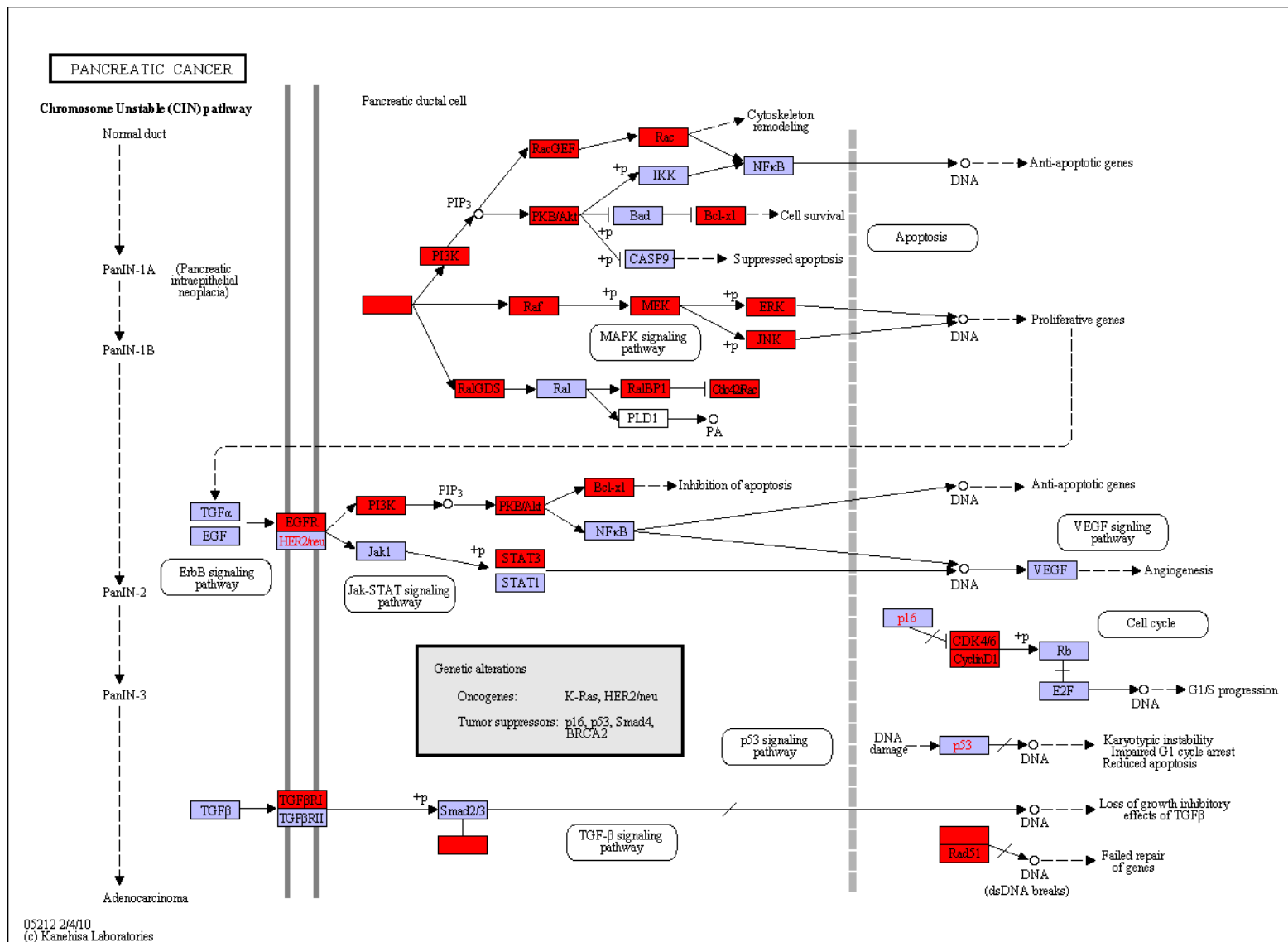

Figure 48: ko05212 Pancreatic cancer

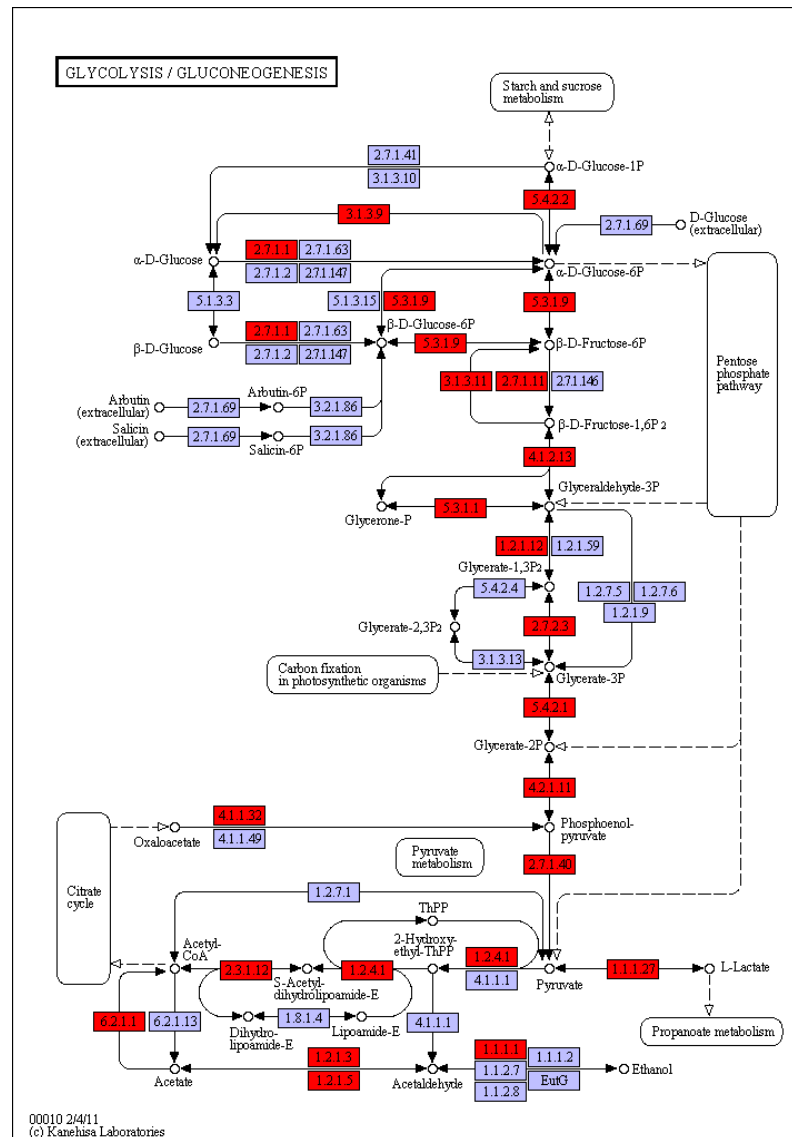

Figure 49: ko00010 Glycolysis / Gluconeogenesis

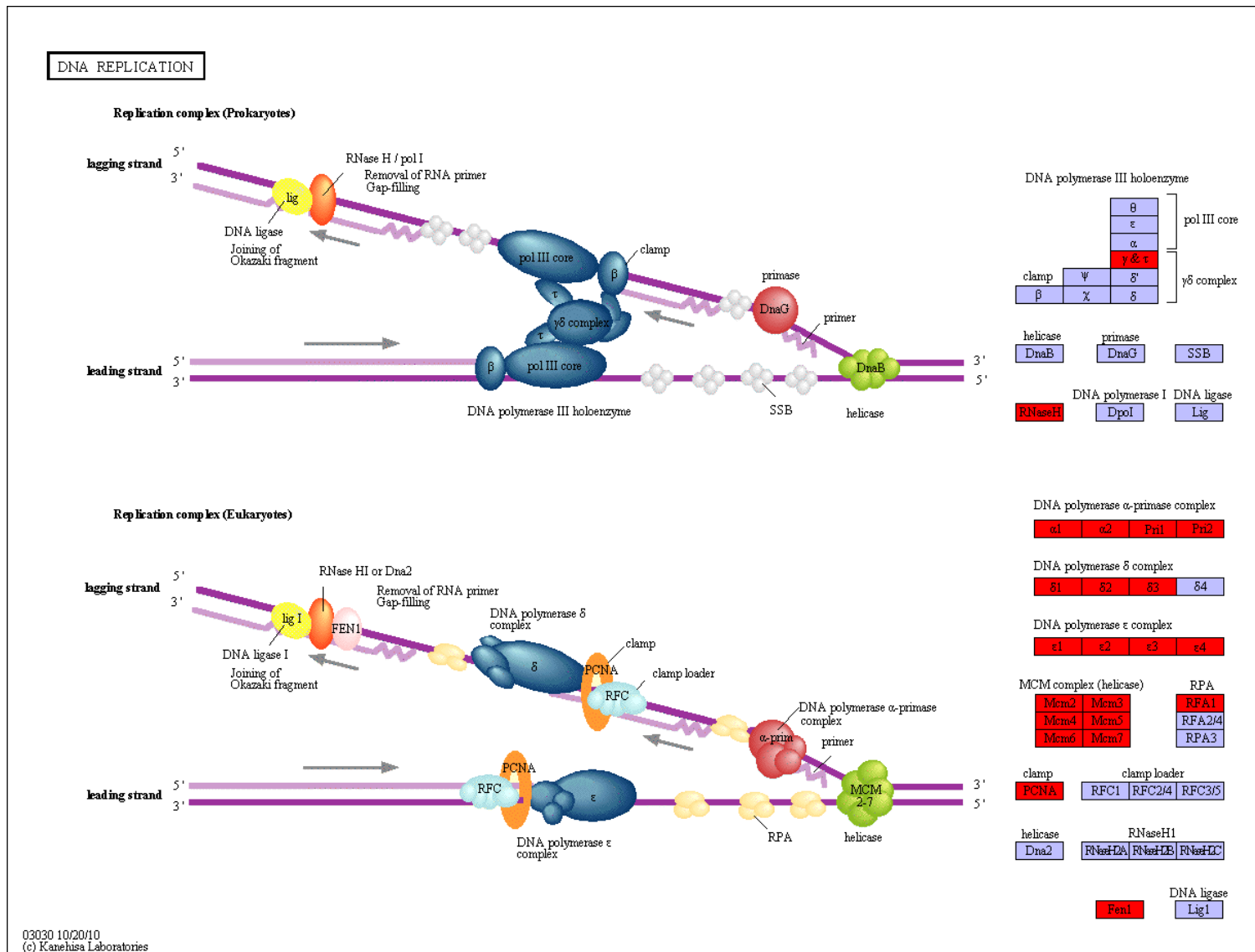

Figure 50: ko03030 DNA replication



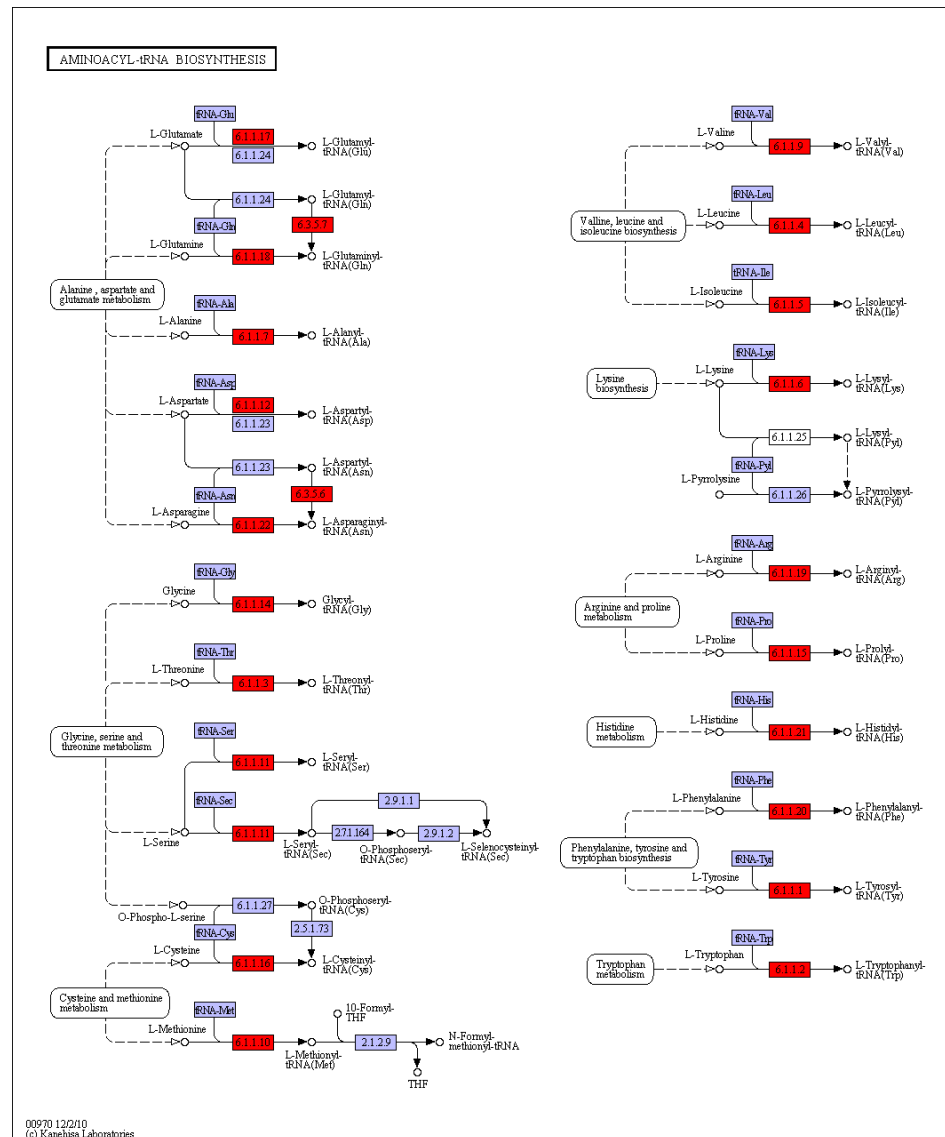

Figure 52: ko00970 Aminoacyl-tRNA biosynthesis

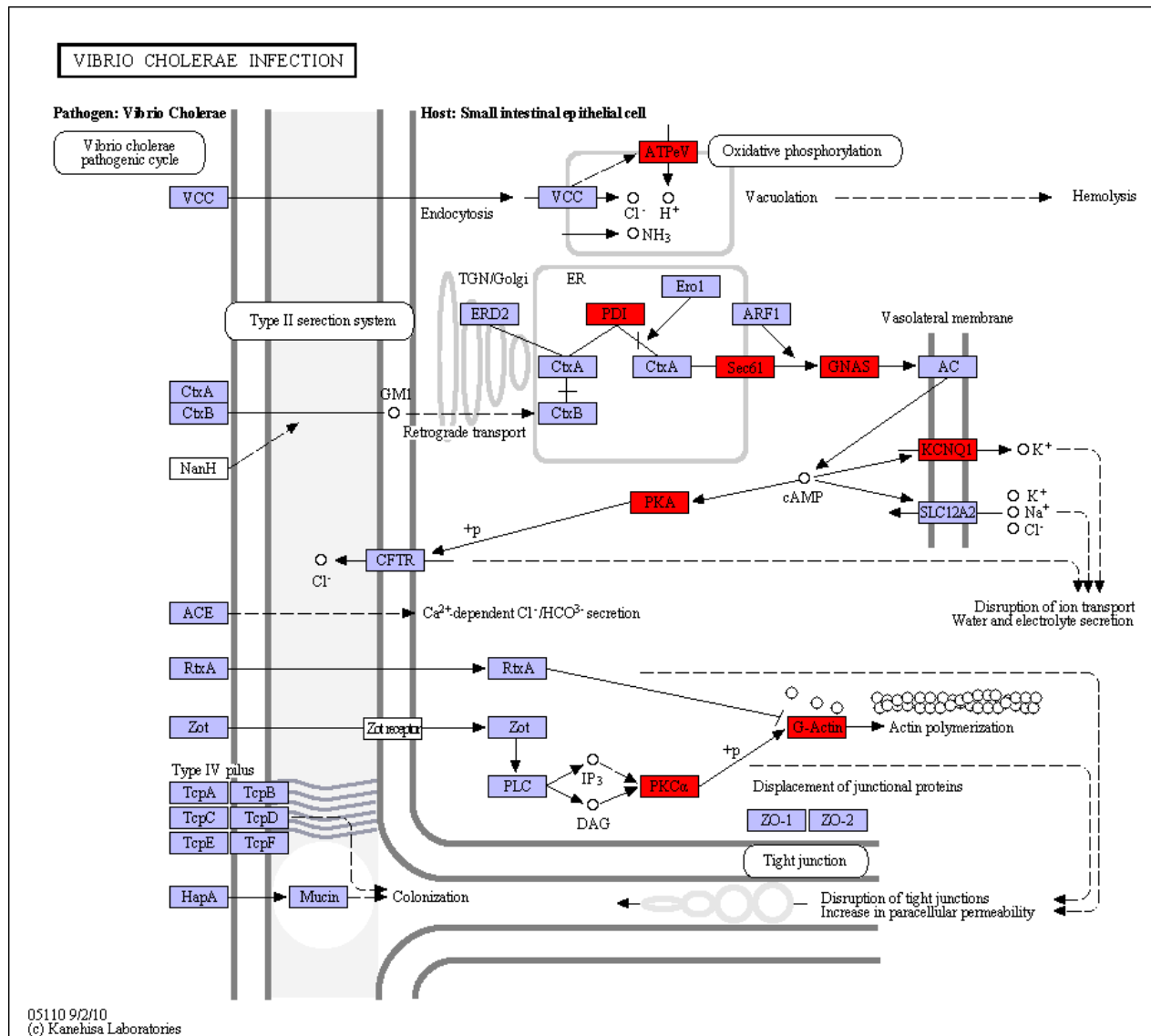

Figure 53: ko05110 *Vibrio cholerae* infection

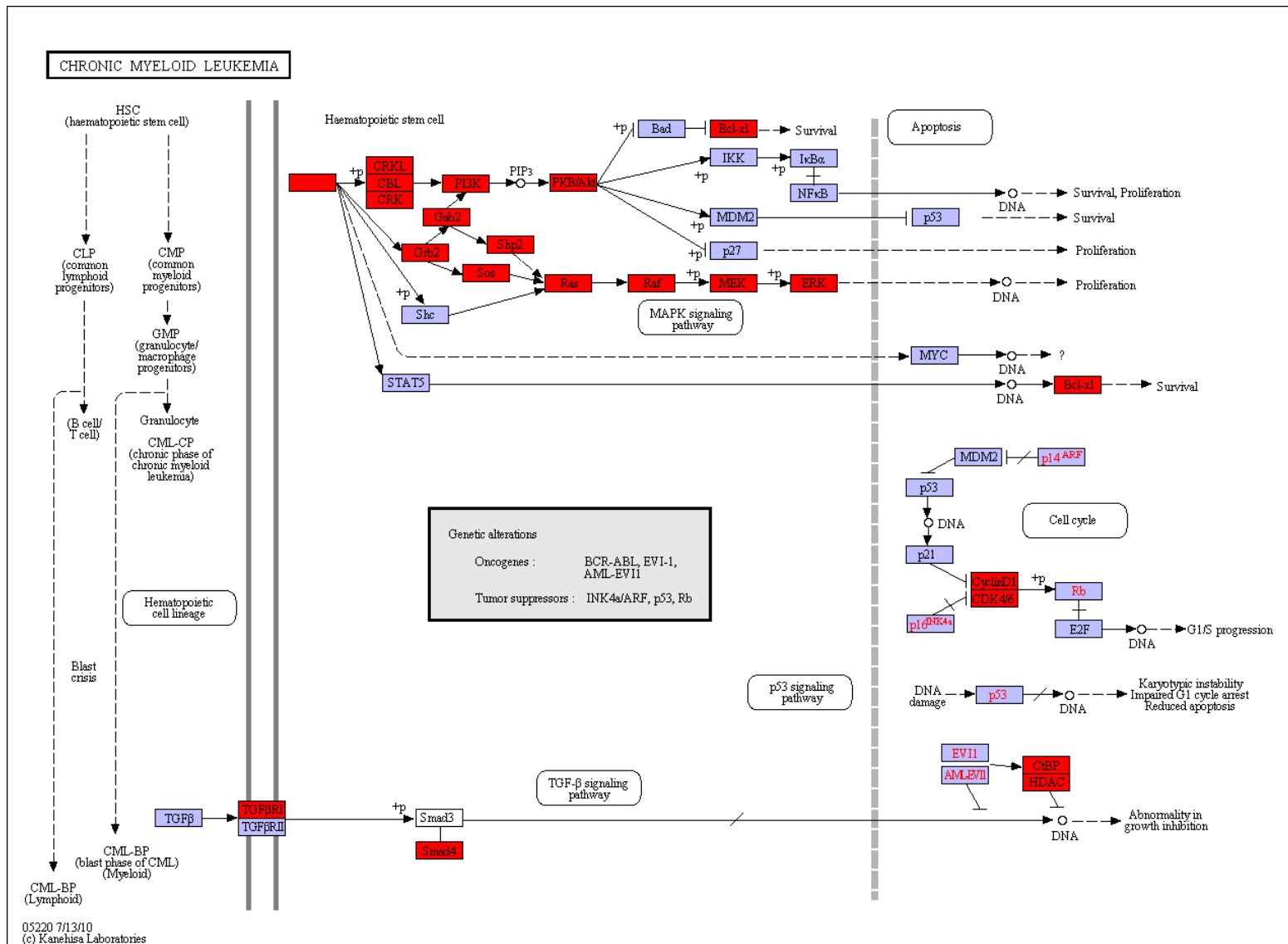

Figure 54: ko05220 Chronic myeloid leukemia

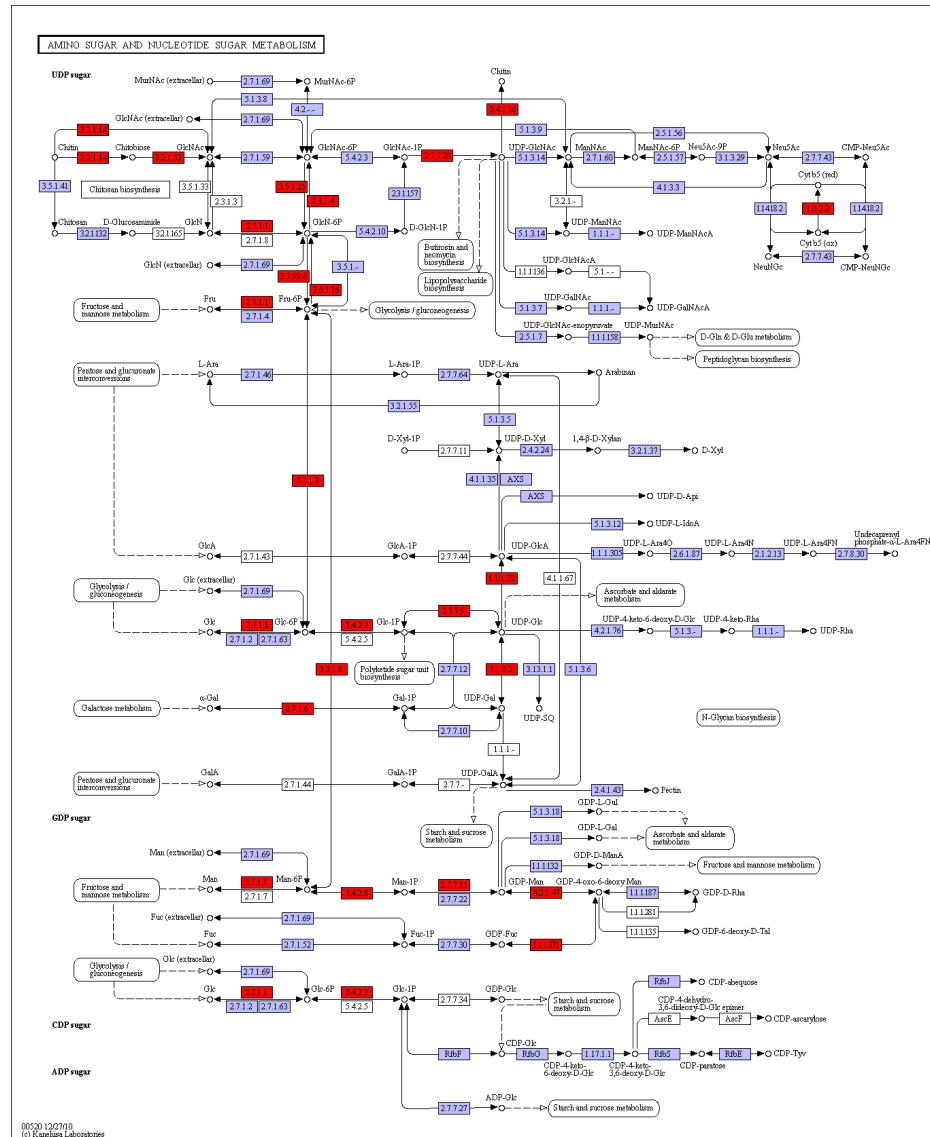

Figure 55: ko00520 Amino sugar and nucleotide sugar metabolism



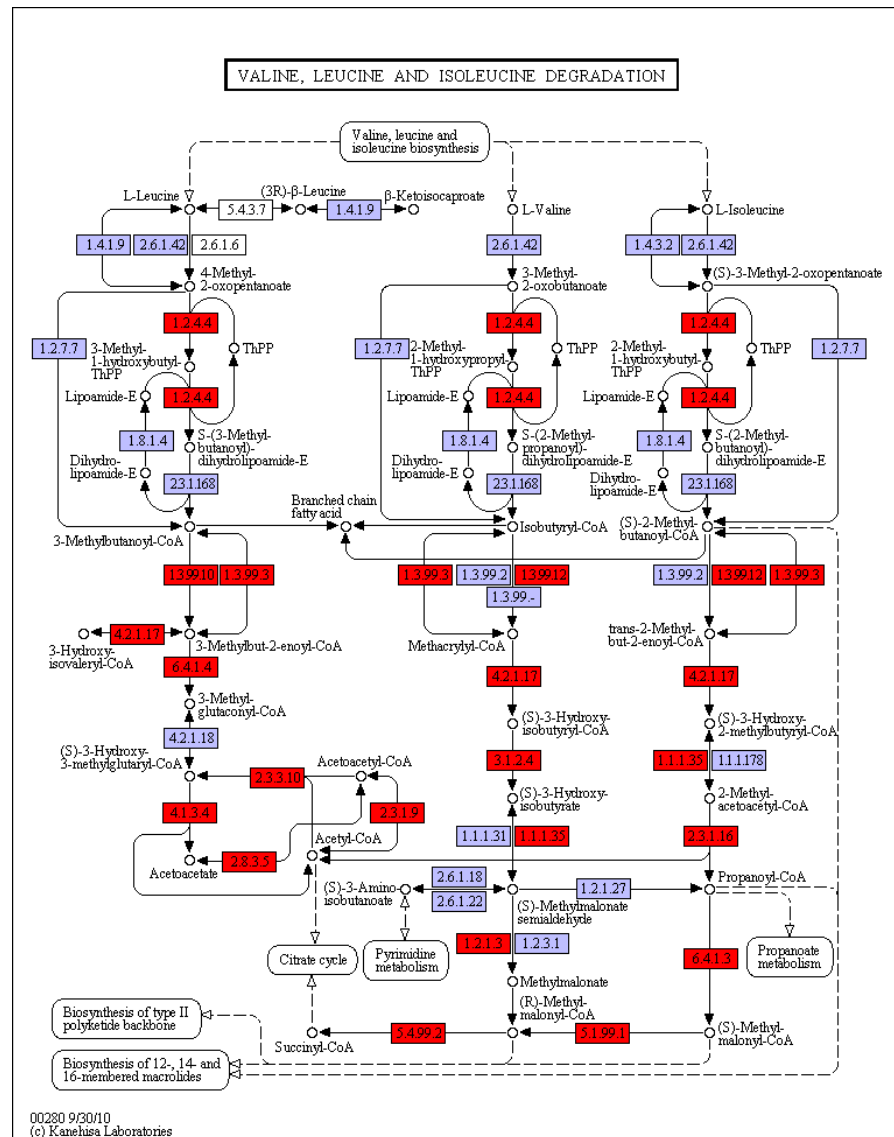

Figure 56: ko00280 Valine, leucine and isoleucine degradation

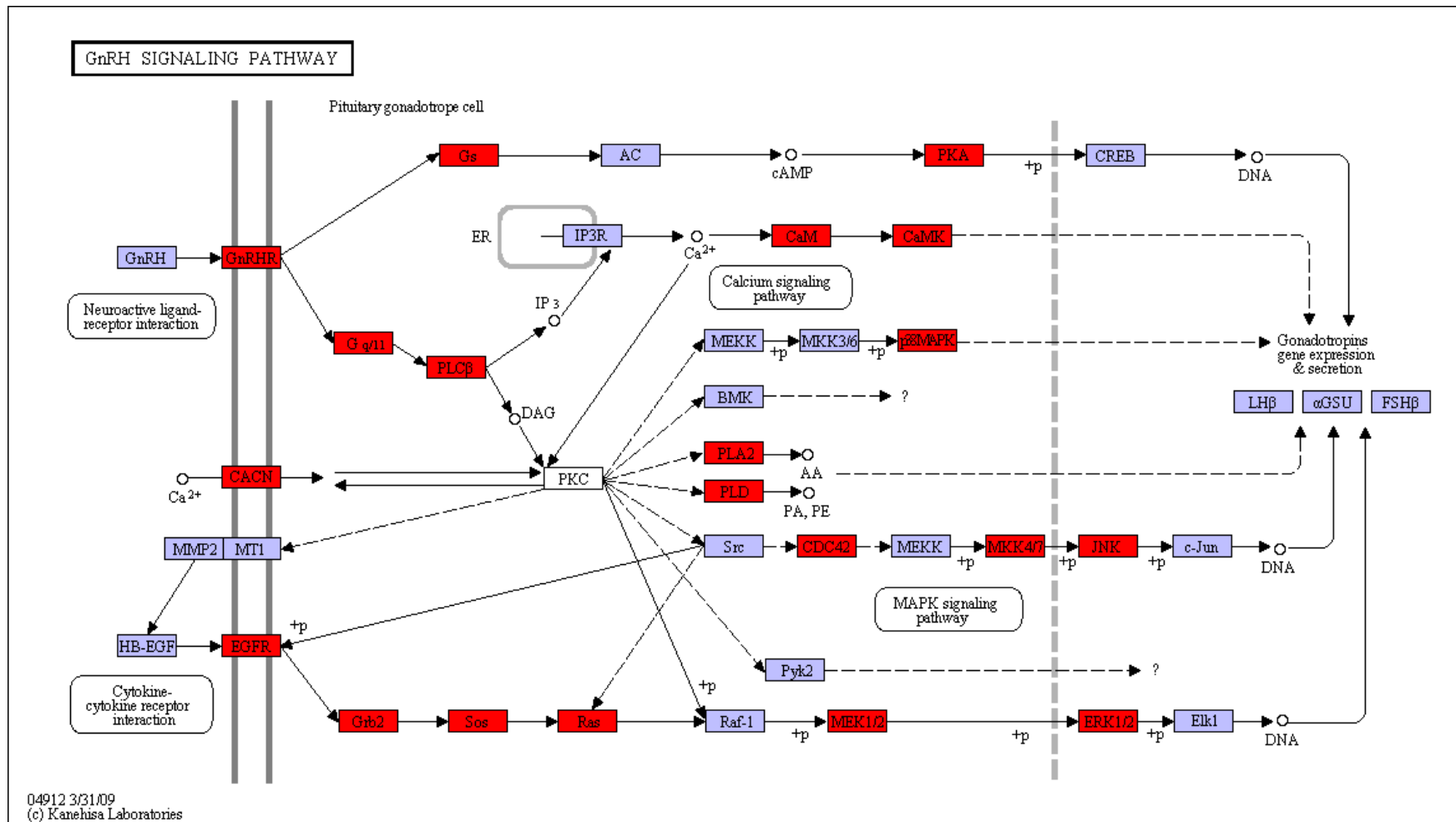

Figure 57: ko04912 GnRH signaling pathway

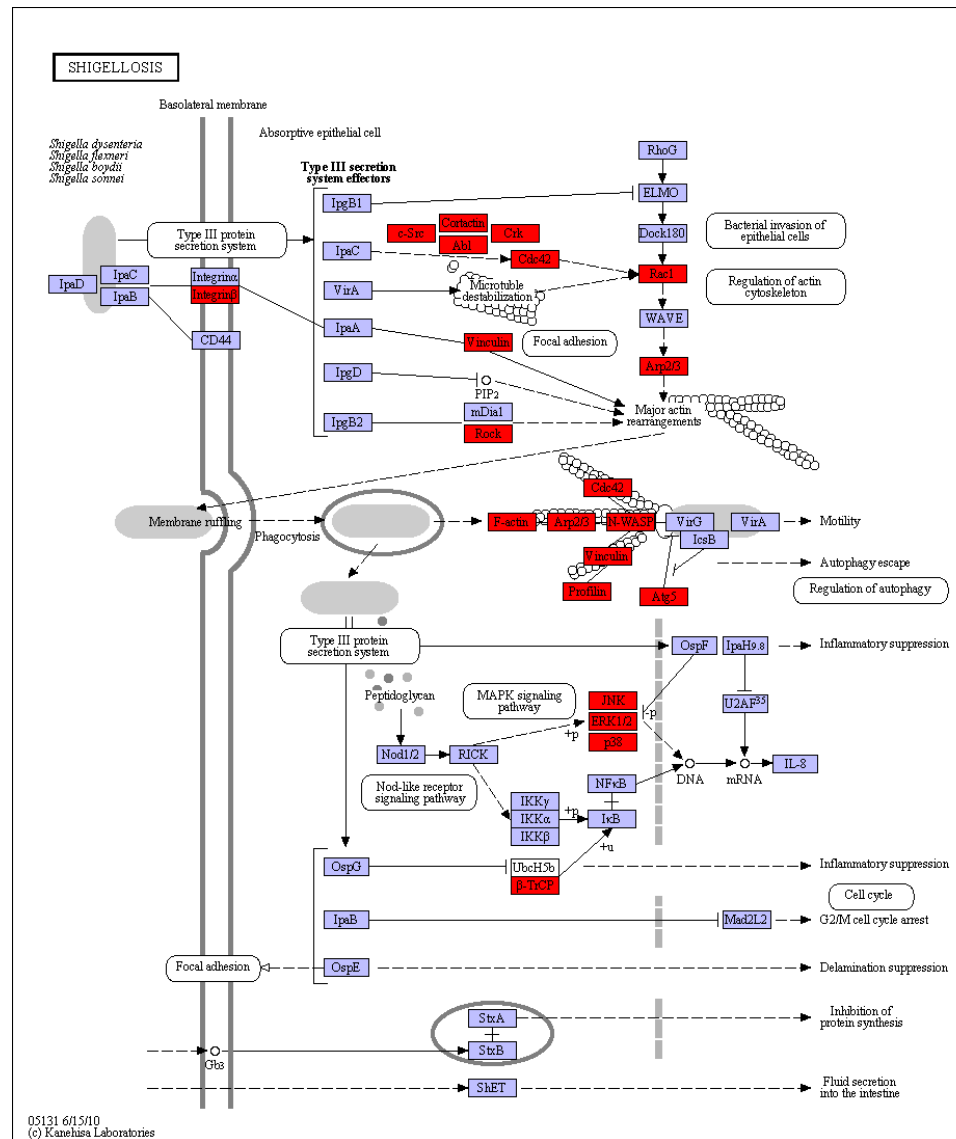

Figure 58: ko05131 Shigellosis

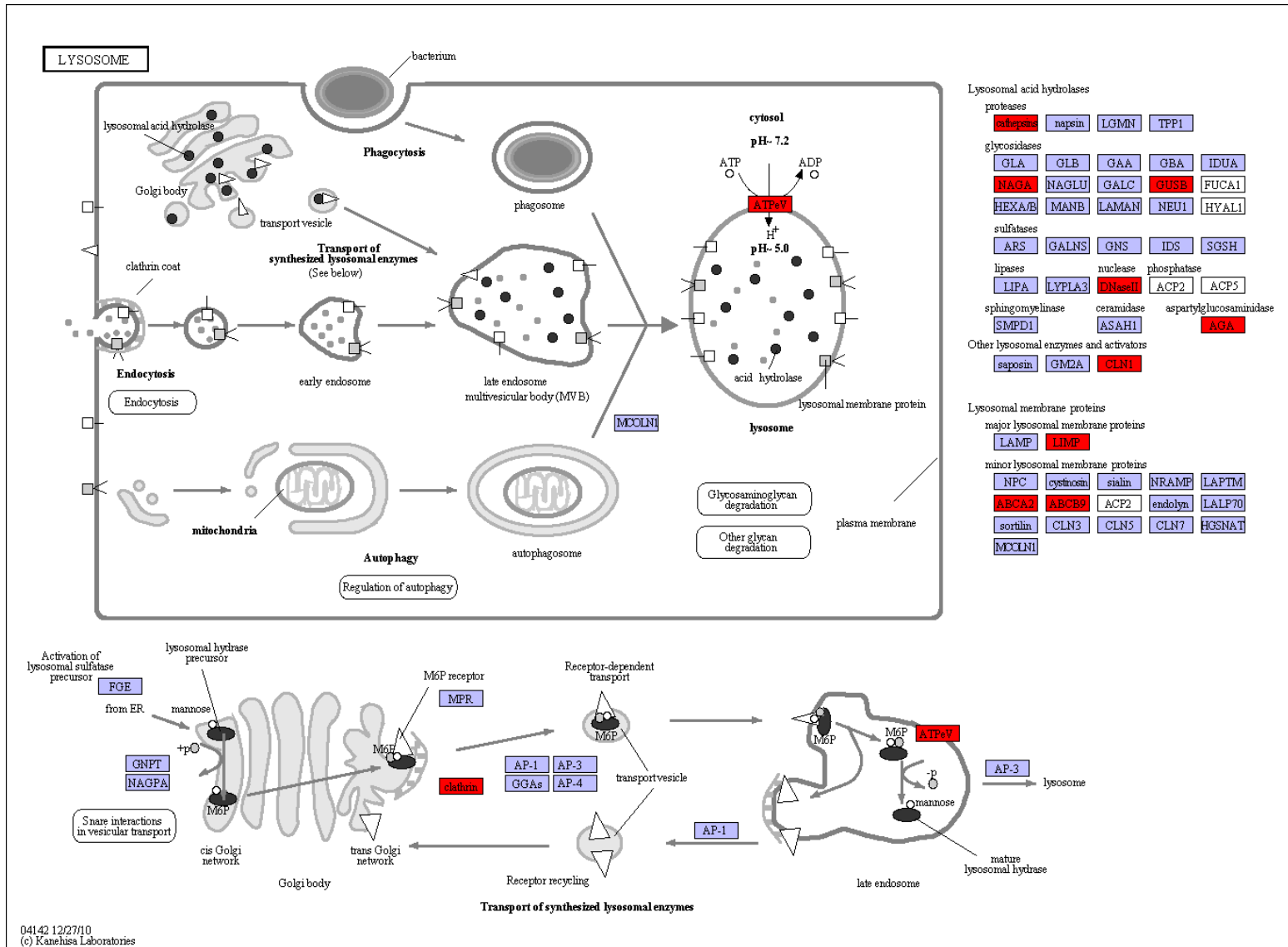

Figure 59: ko04142 Lysosome

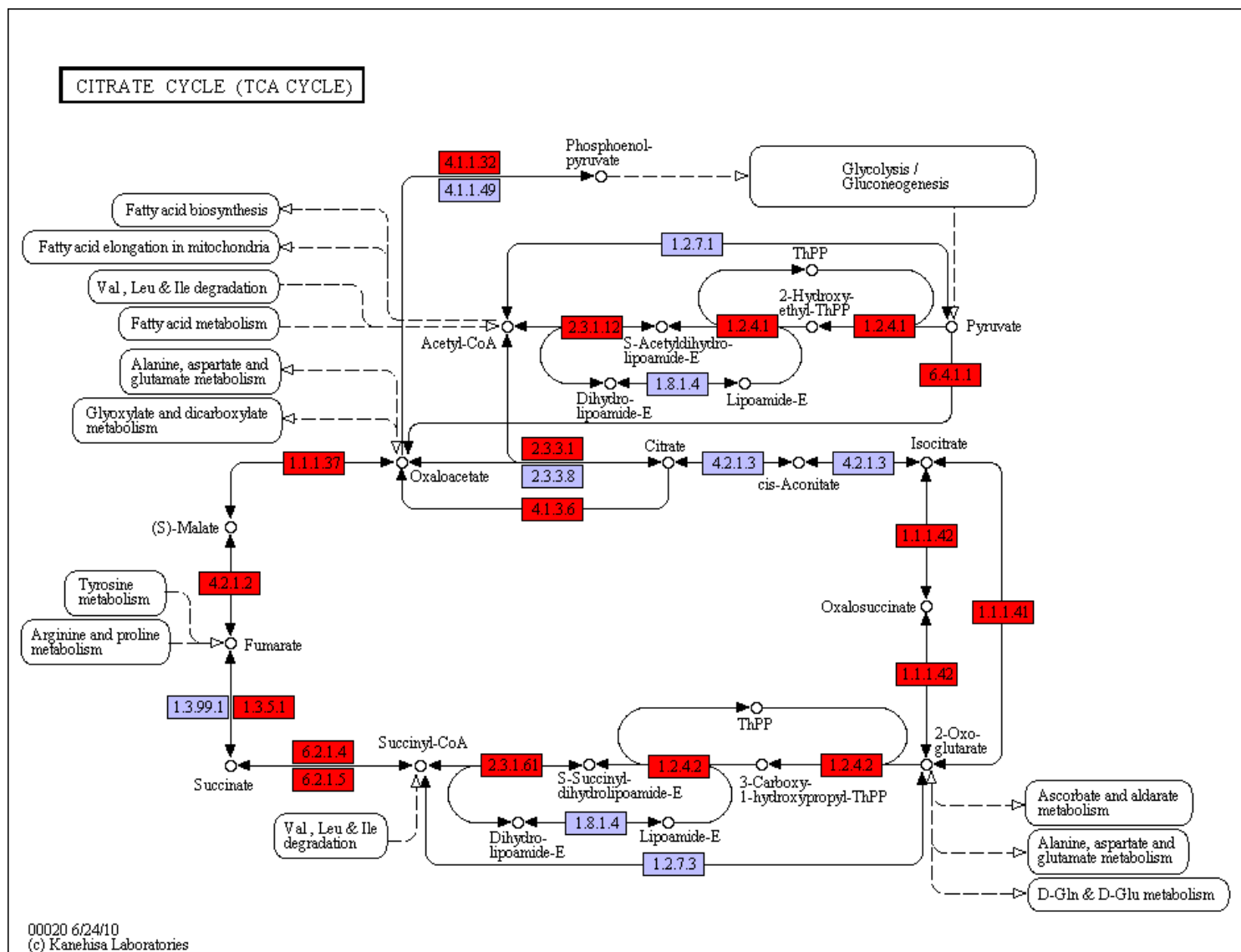

Figure 60: ko00020 Citrate cycle (TCA cycle)

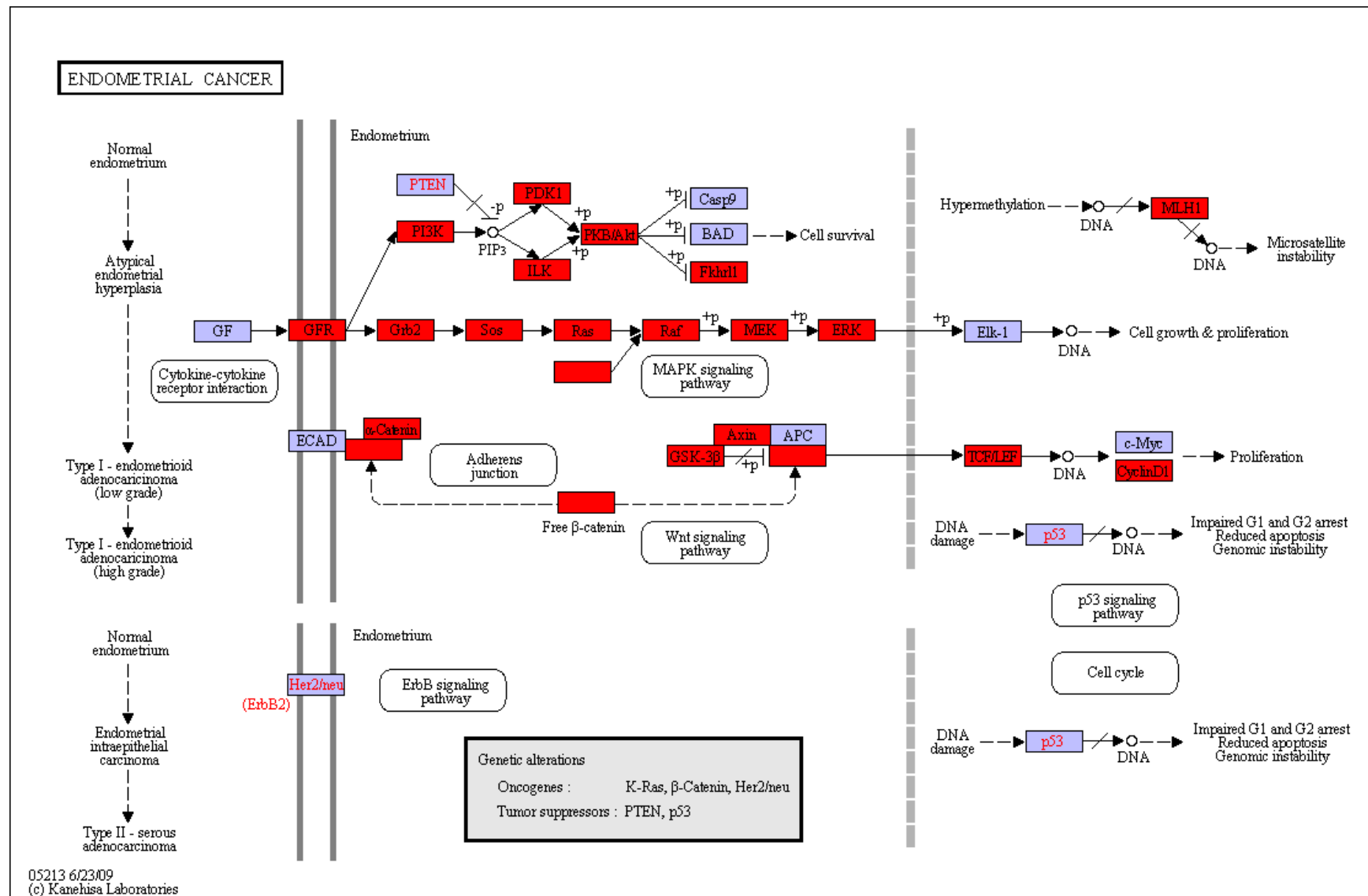
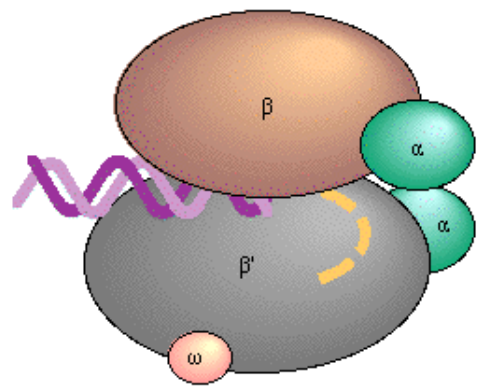
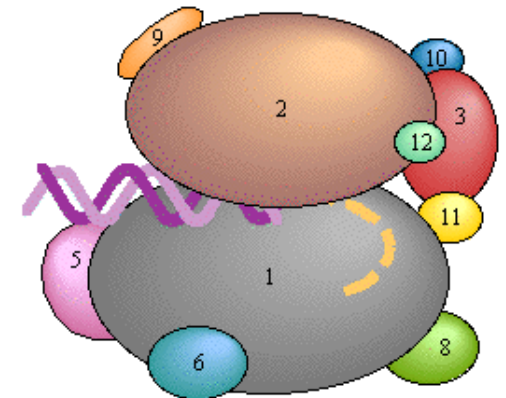

Figure 61: ko05213 Endometrial cancer

RNA POLYMERASE



RNA polymerase (*Thermus aquaticus*)



RNA polymerase II (*Saccharomyces cerevisiae*)

Bacterial

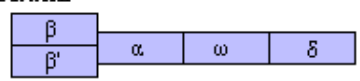

Archaeal

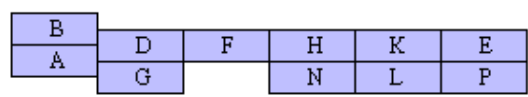

Eukaryotic Pol II

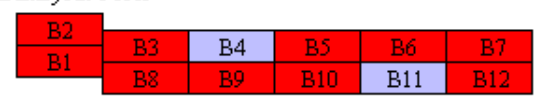

Eukaryotic Pol III

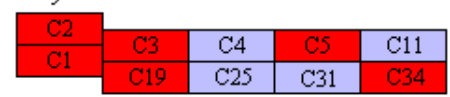

Eukaryotic Pol I

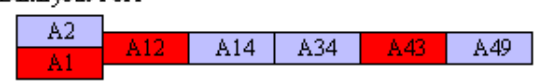

03020 6/14/10  
(c) Kanehisa Laboratories

Figure 62: ko03020 RNA polymerase

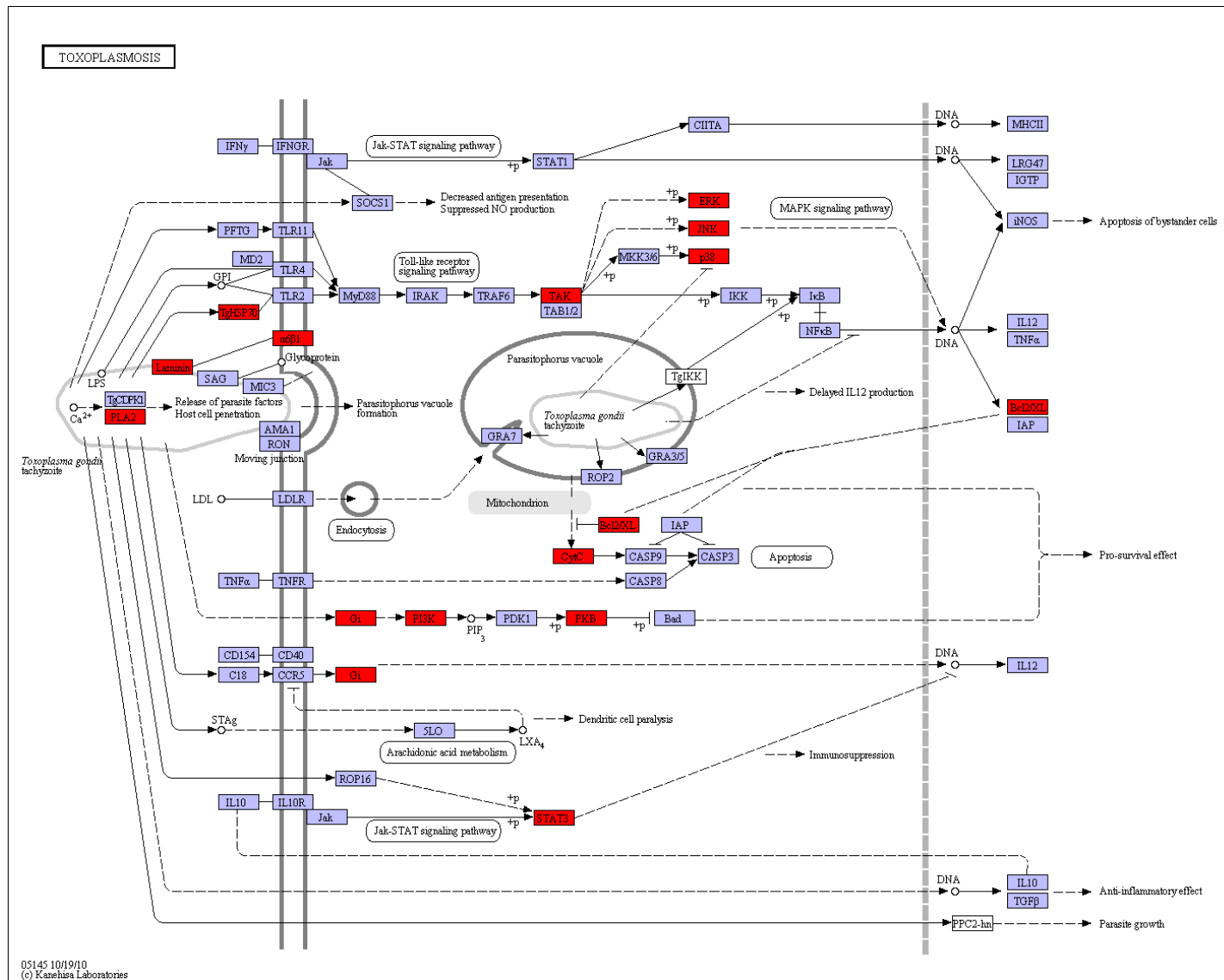

Figure 63: ko05145 Toxoplasmosis



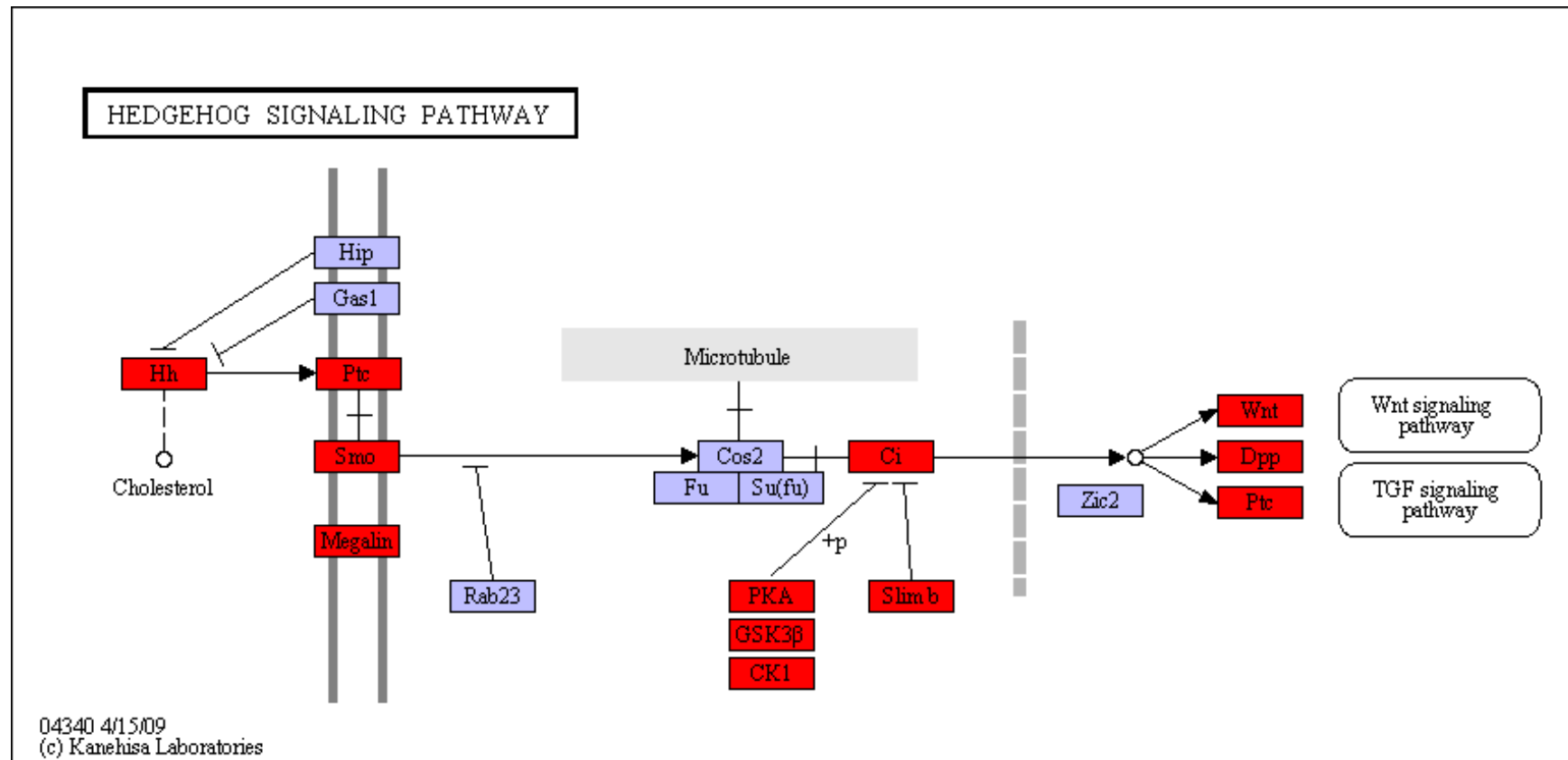

Figure 64: ko04340 Hedgehog signaling pathway

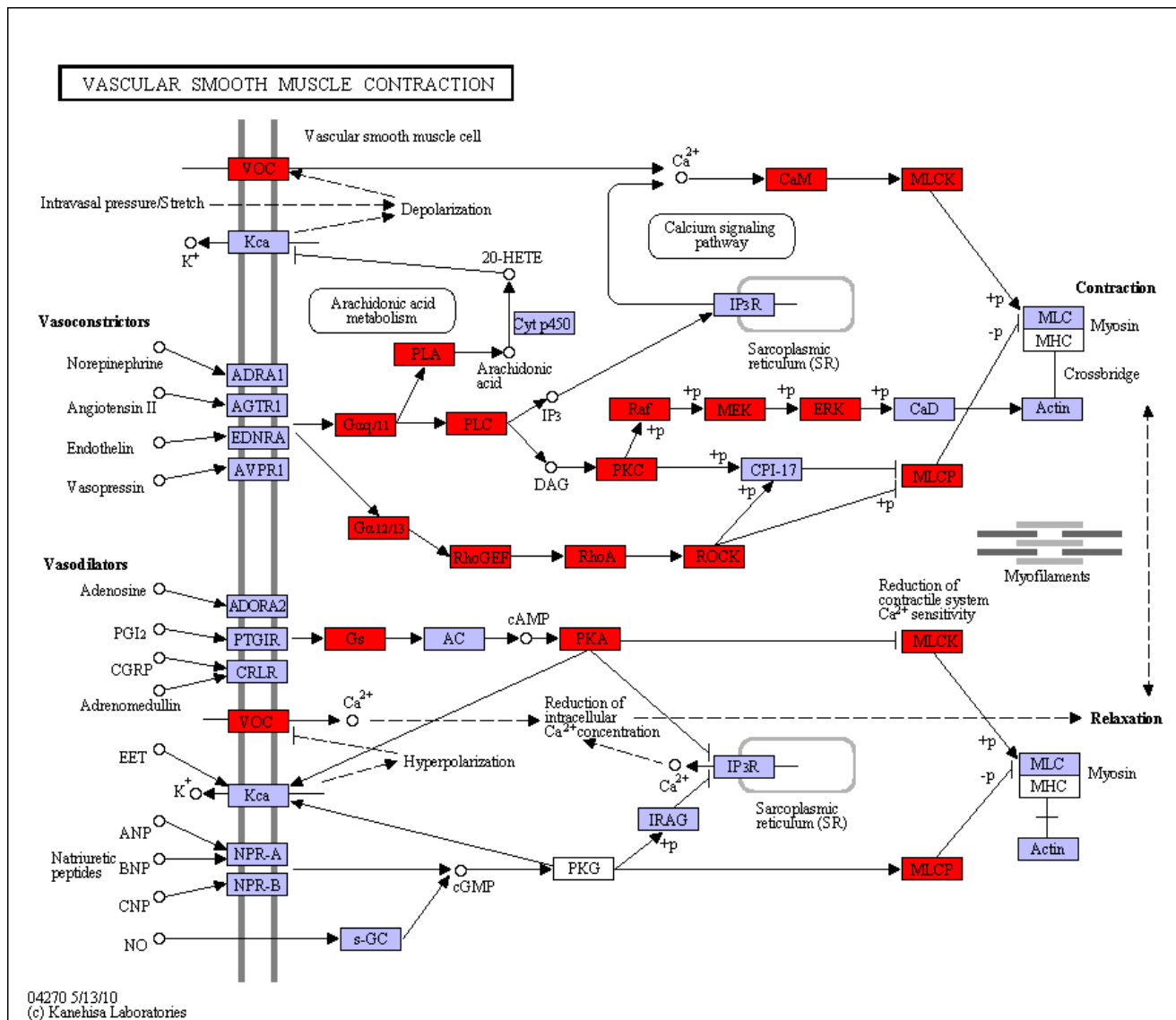

Figure 65: ko04270 Vascular smooth muscle contraction

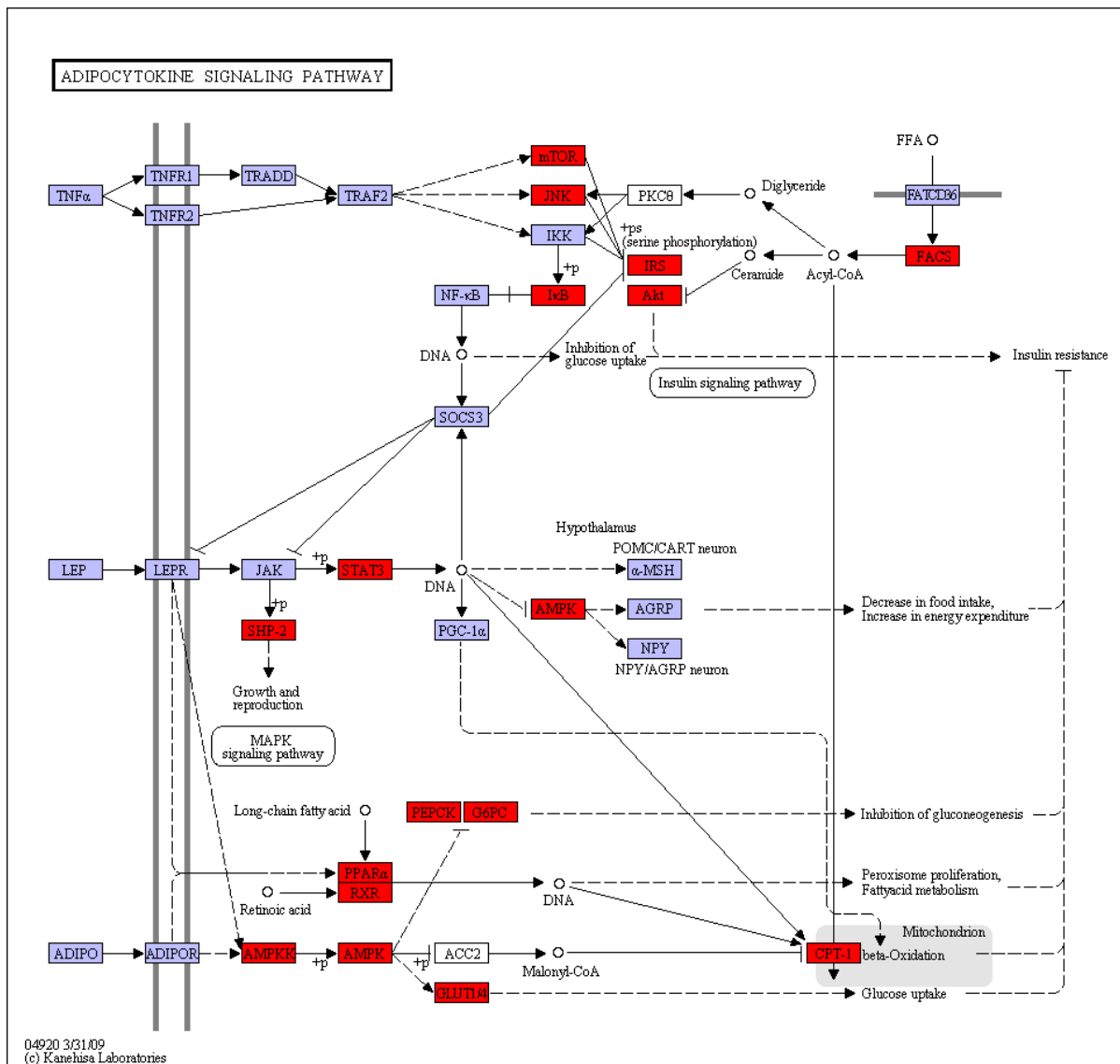

Figure 66: ko04920 Adipocytokine signaling pathway

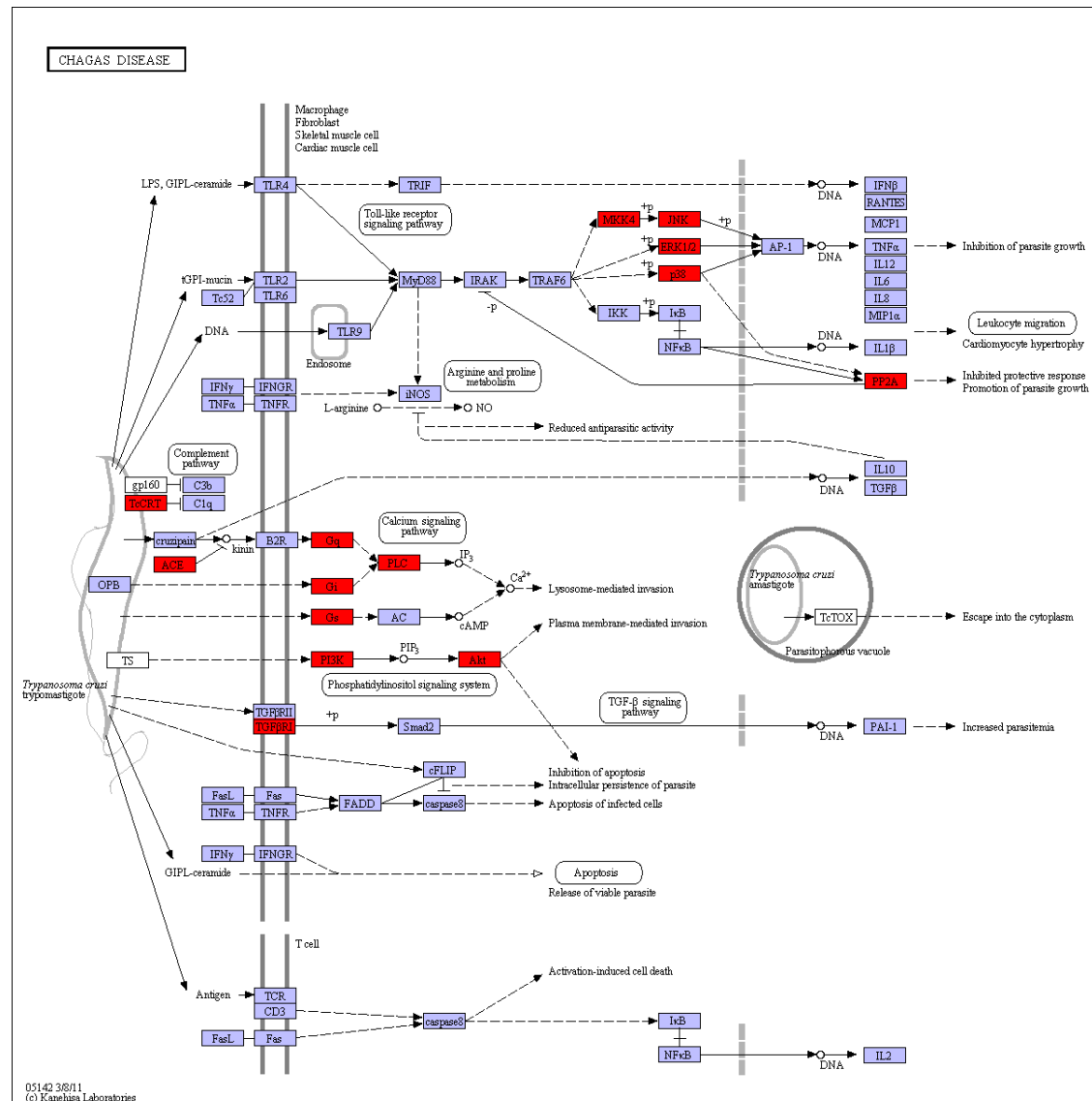

Figure 67: ko05142 Chagas disease (American trypanosomiasis)

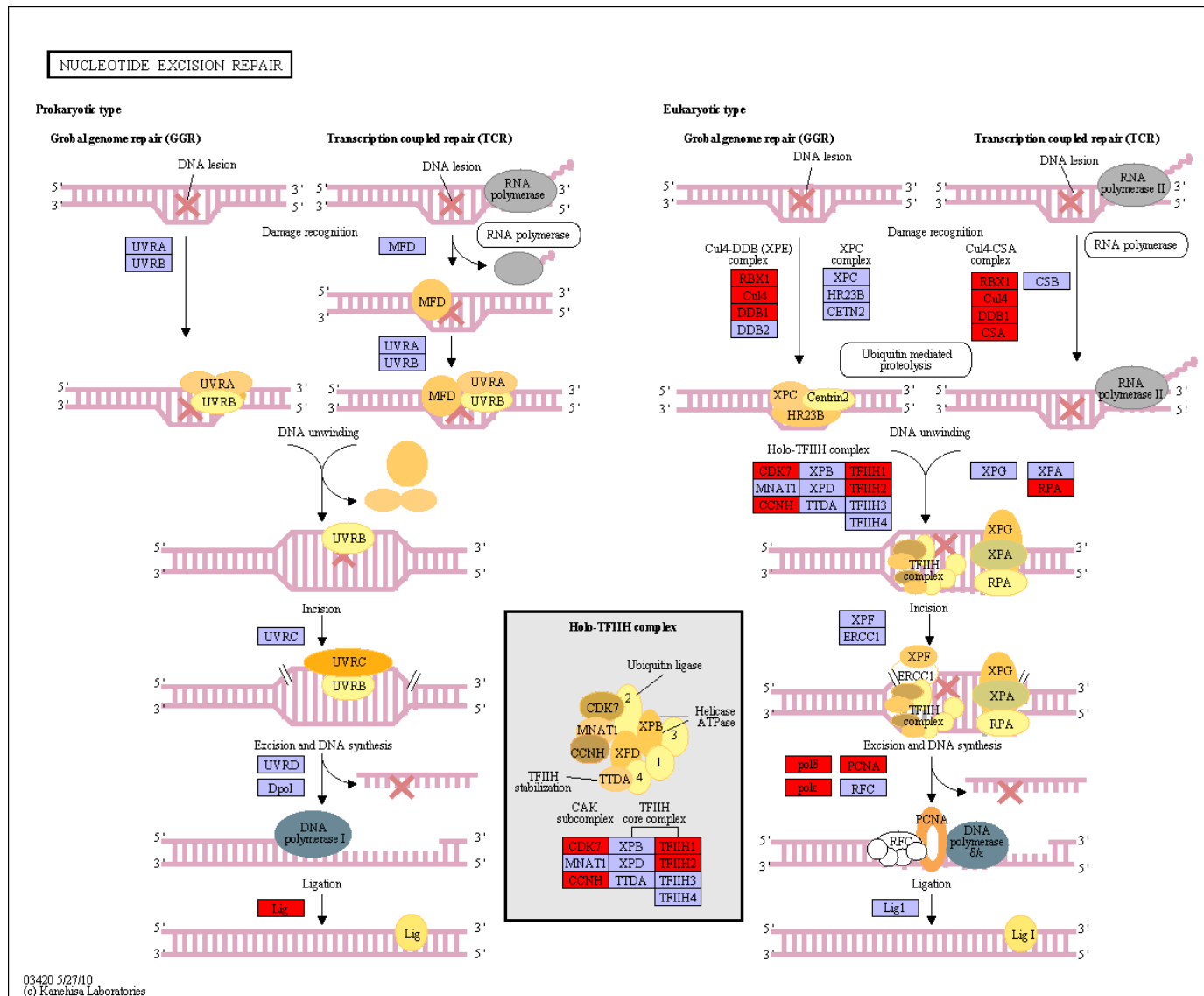

Figure 68: ko03420 Nucleotide excision repair

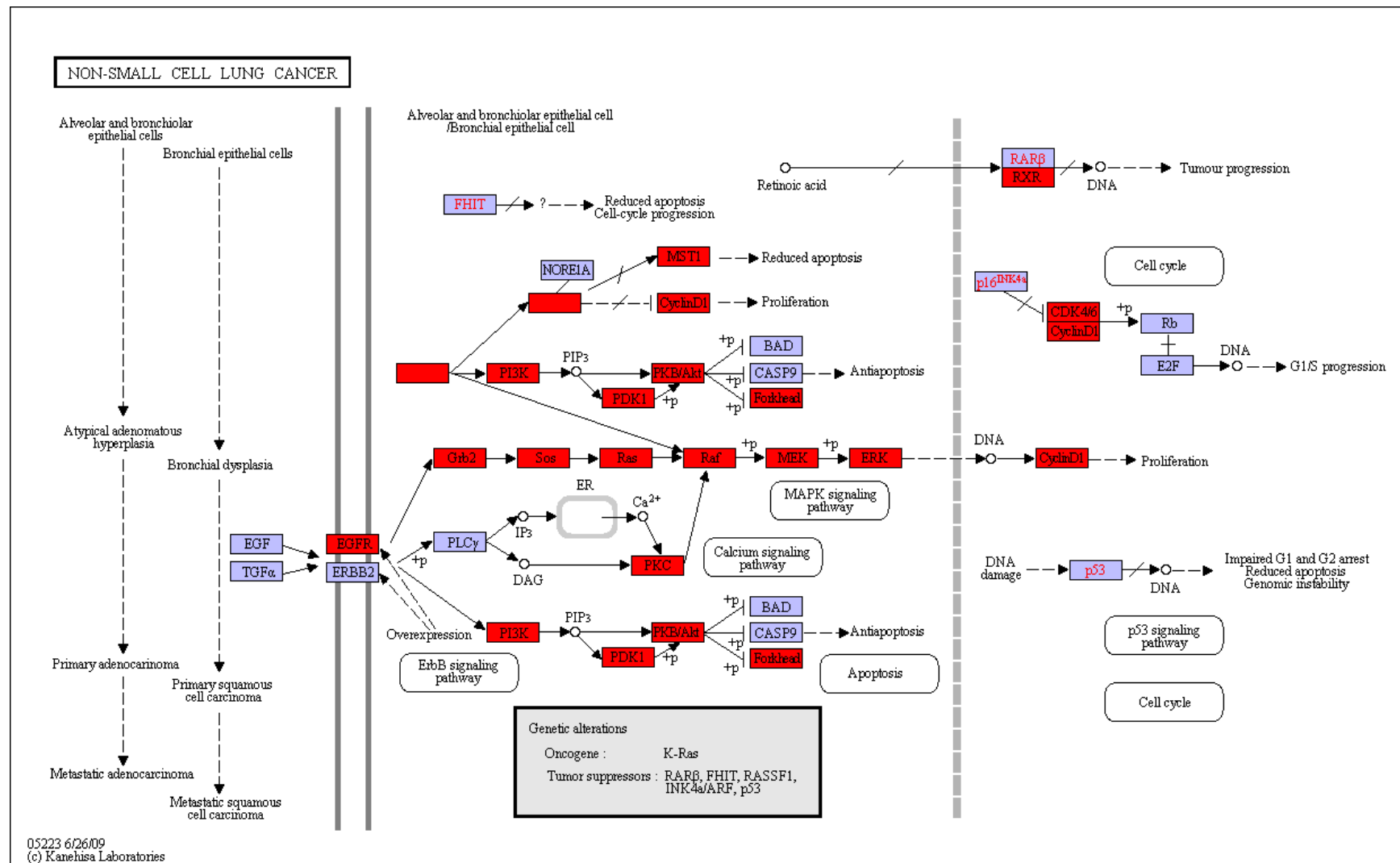

Figure 69: ko05223 Non-small cell lung cancer

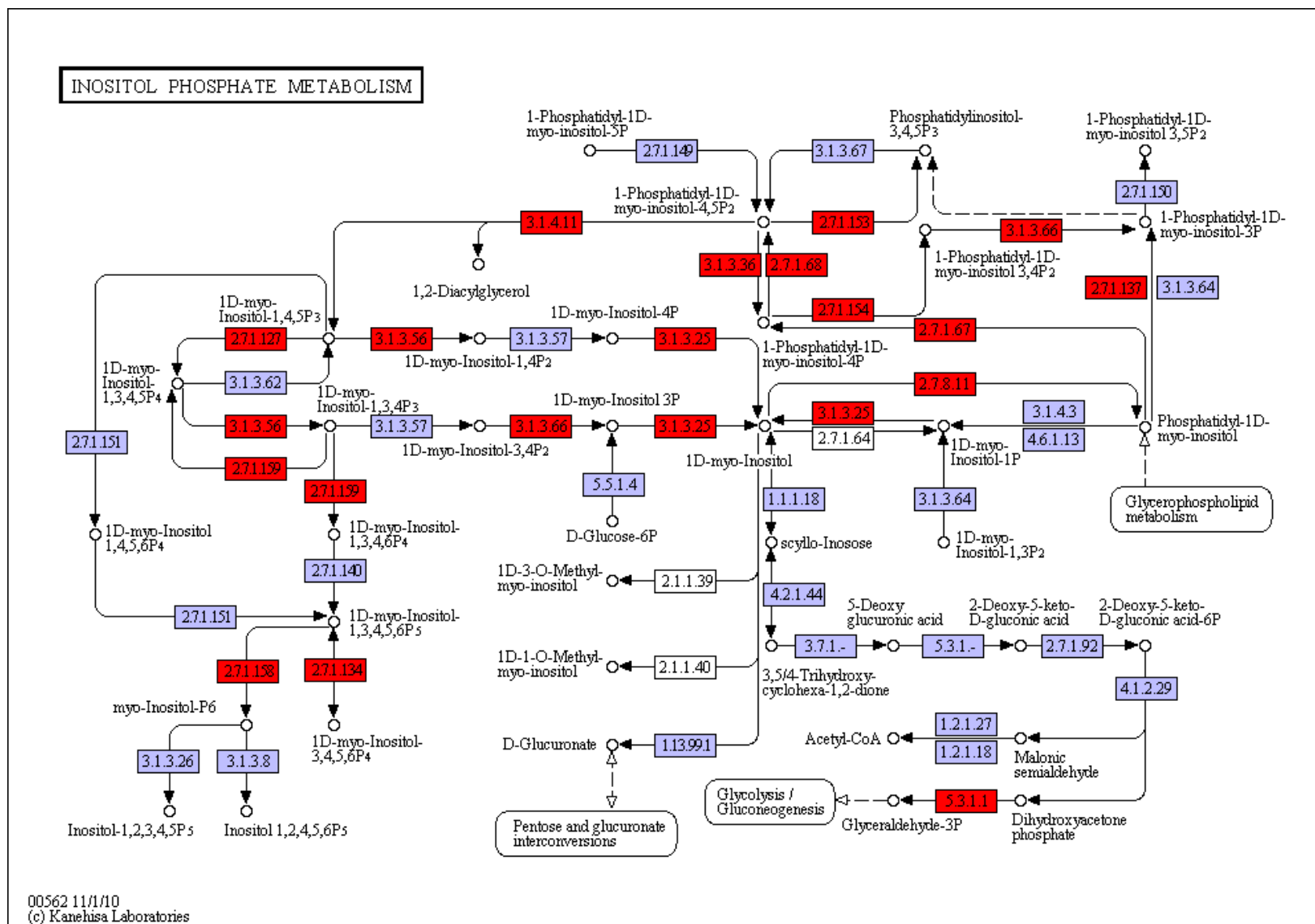

Figure 70: ko00562 Inositol phosphate metabolism

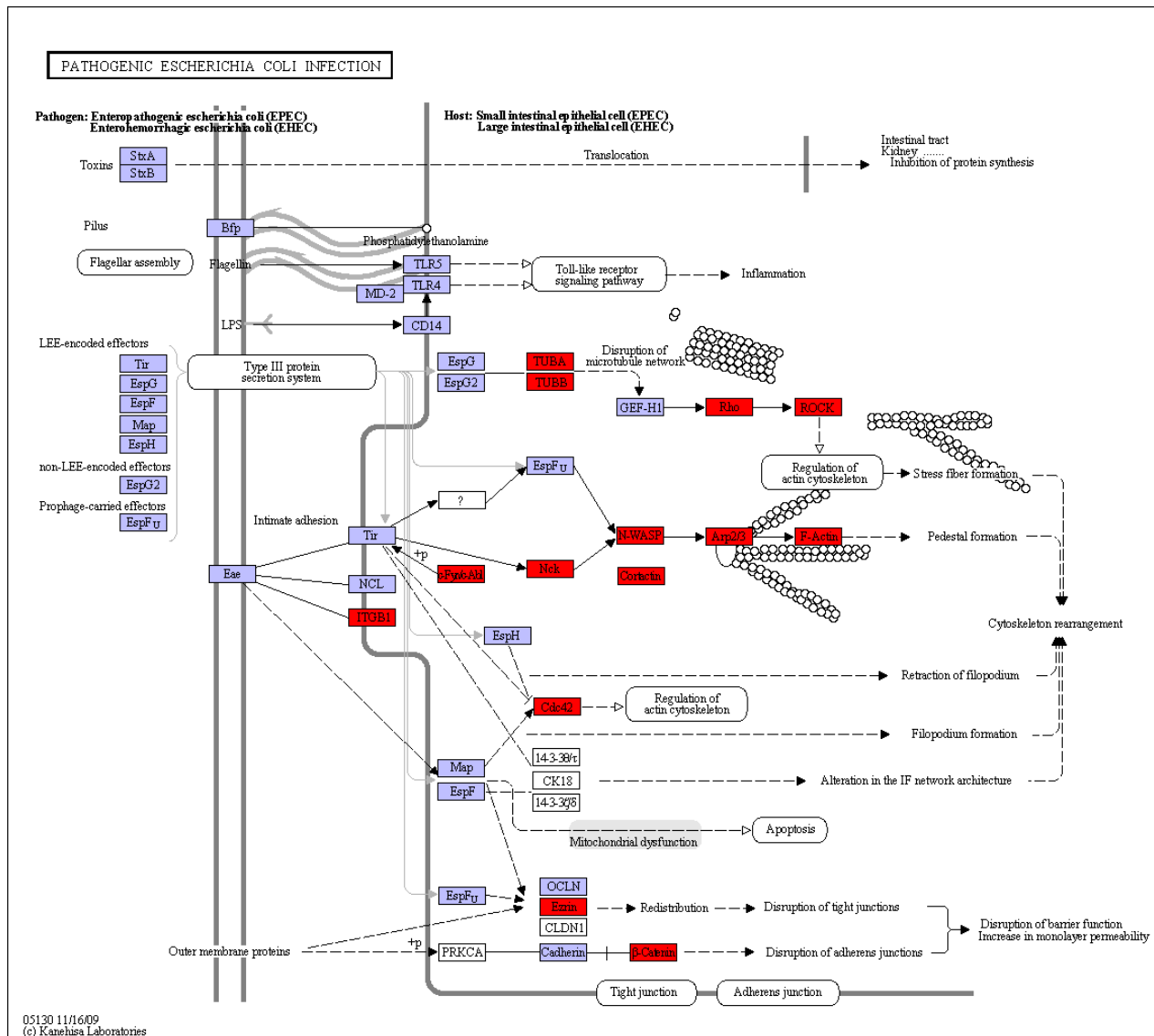

Figure 71: ko05130 Pathogenic *Escherichia coli* infection



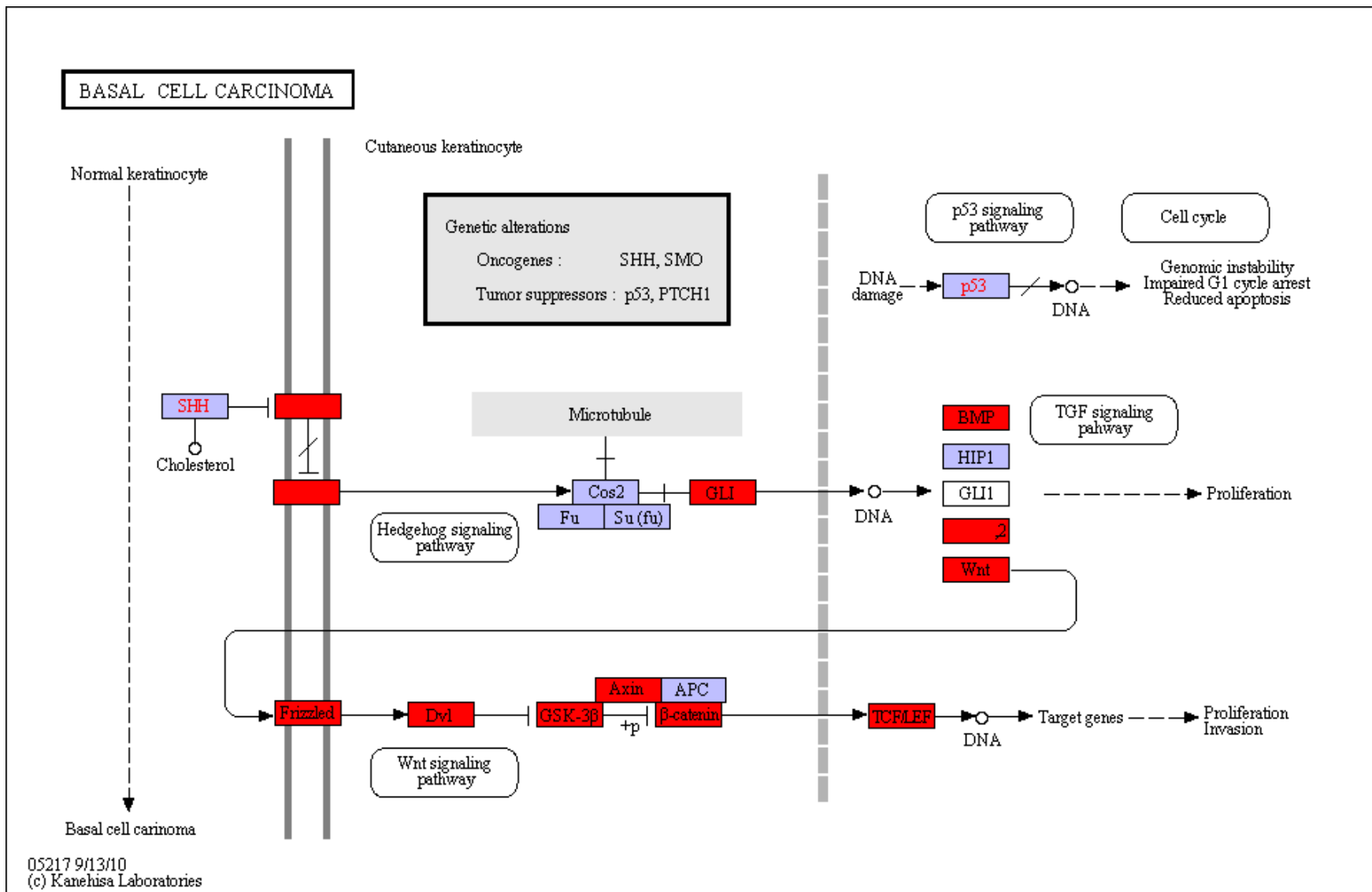
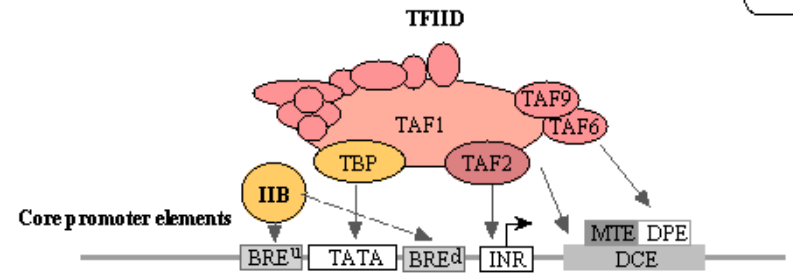
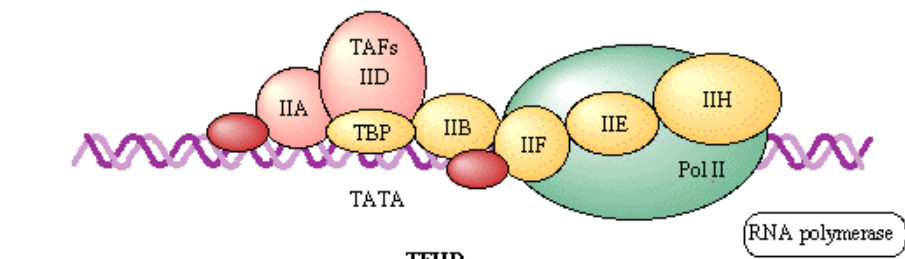

Figure 72: ko05217 Basal cell carcinoma



**BASAL TRANSCRIPTION FACTORS (EUKARYOTES)**



**General transcription factors for RNA polymerase II**

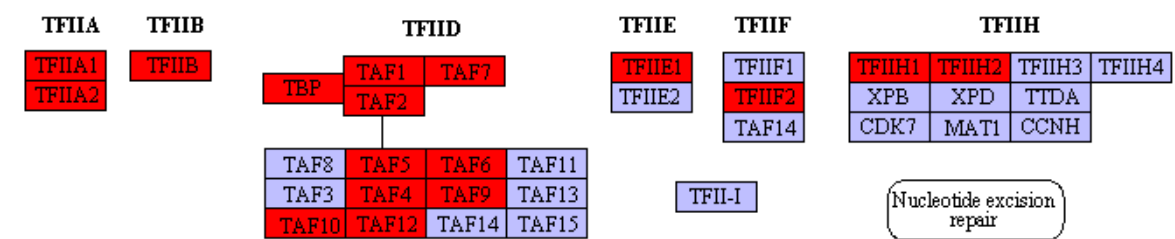

03022 3/15/11  
(c) Kanehisa Laboratories

Figure 74: ko03022 Basal transcription factors

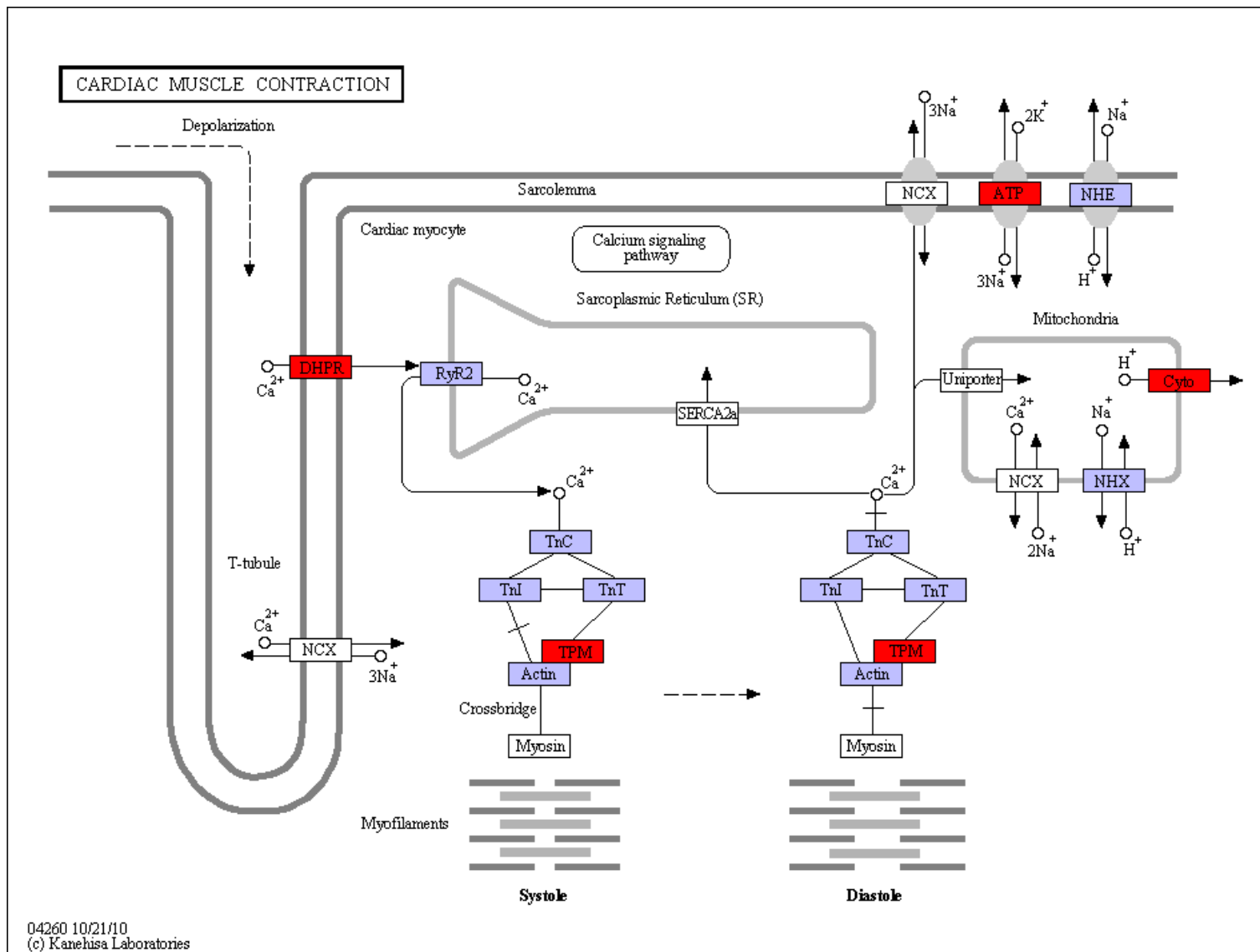

Figure 75: ko04260 Cardiac muscle contraction

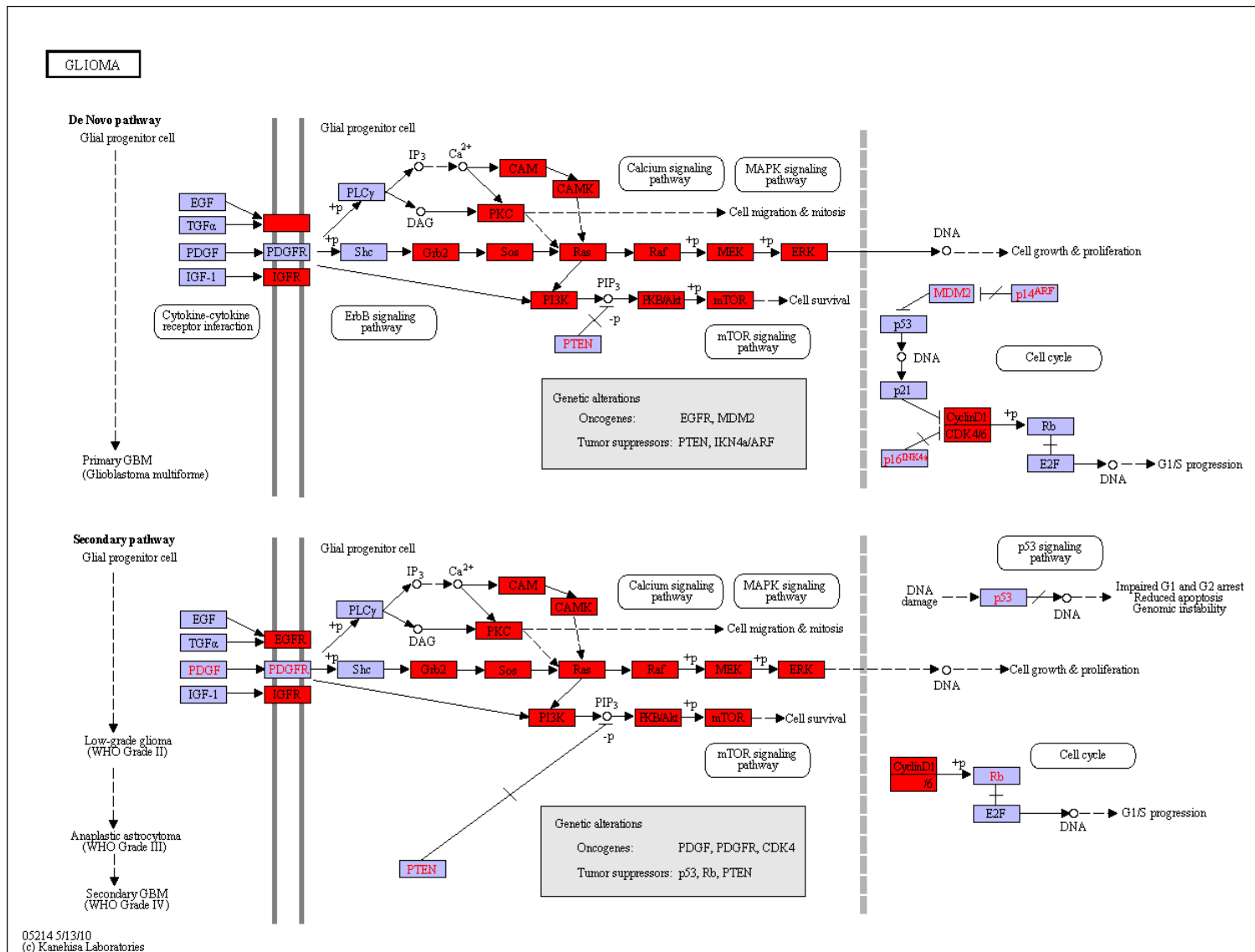

Figure 76: ko05214 Glioma

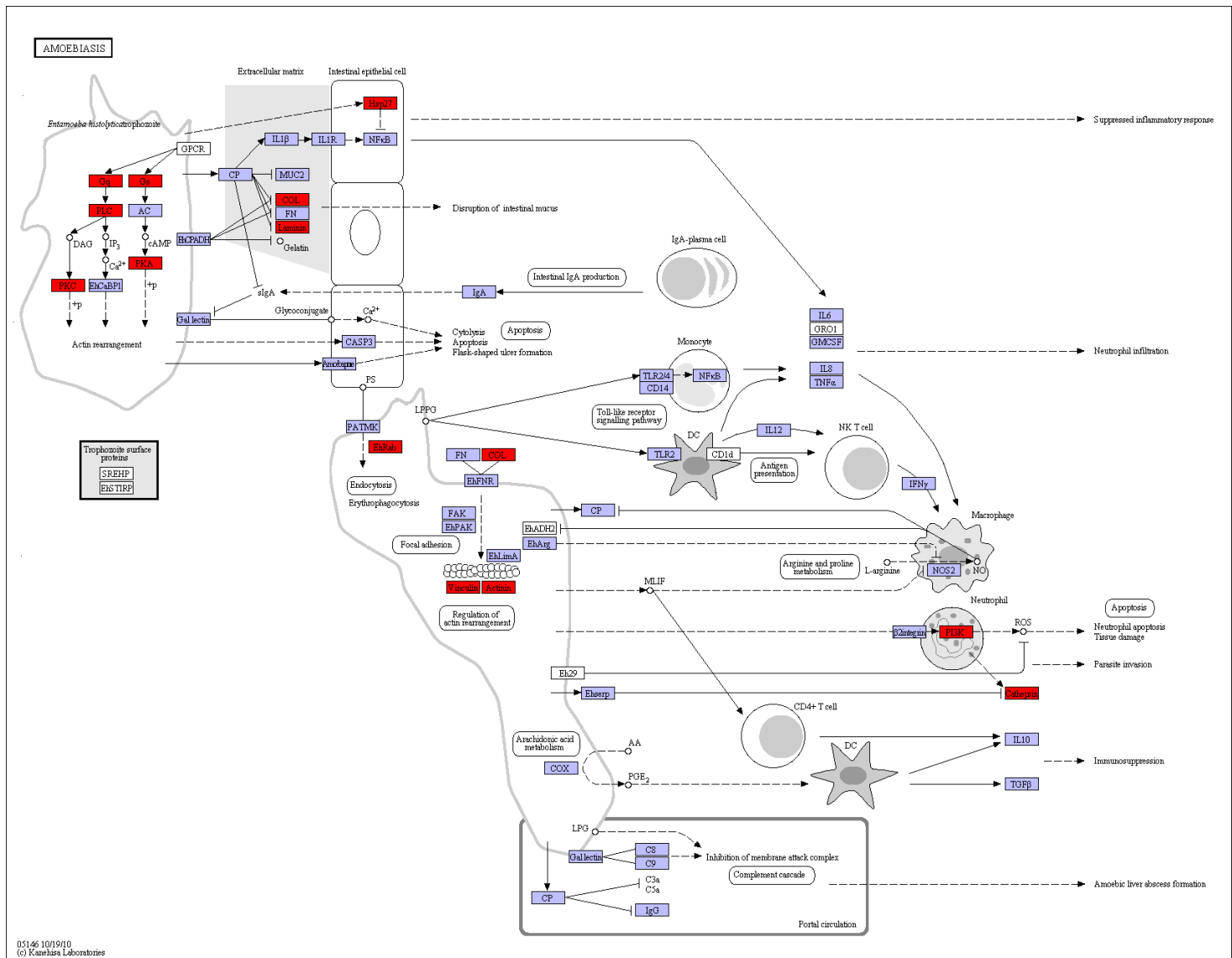

Figure 77: ko05146 Amoebiasis

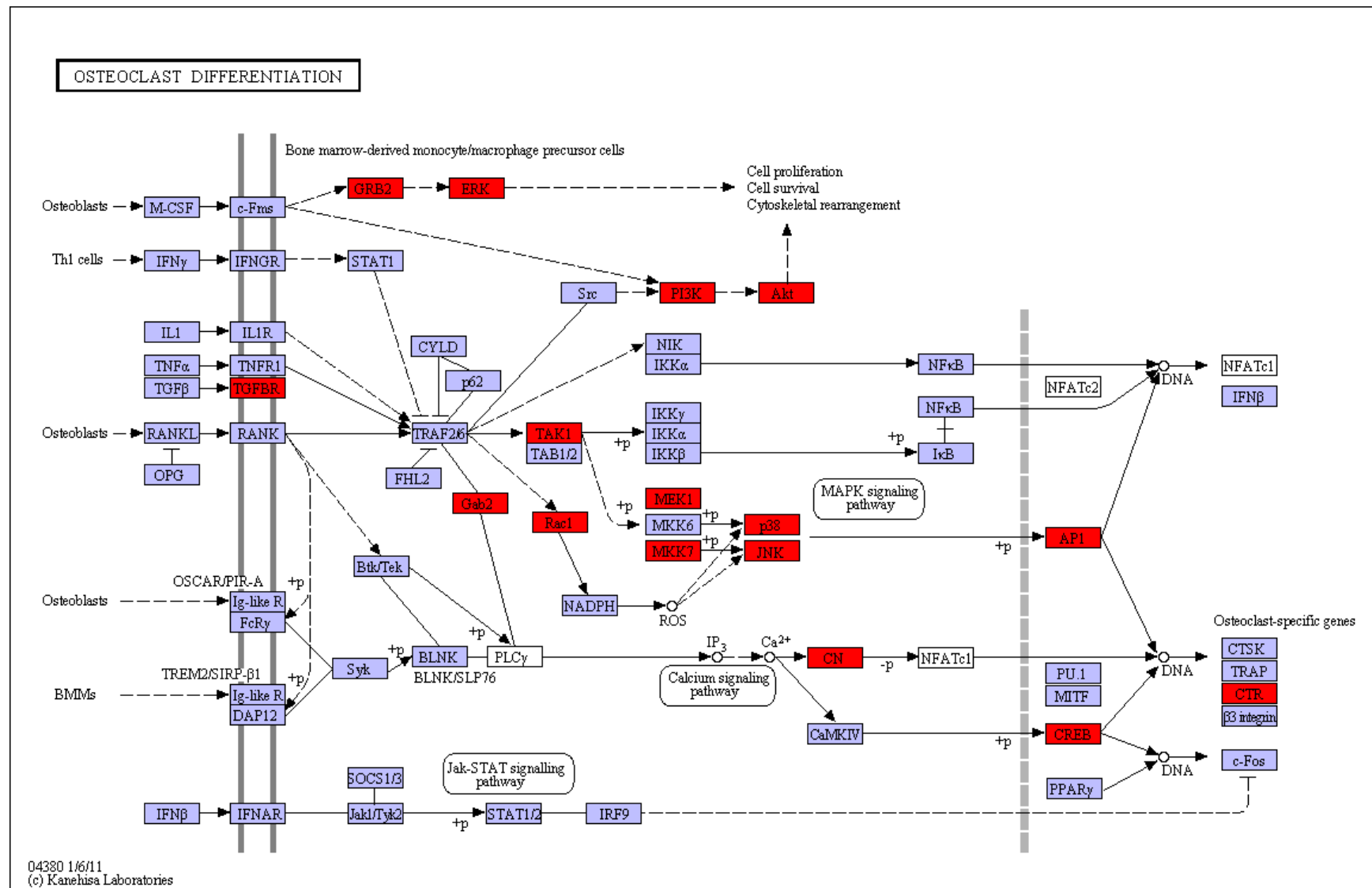

Figure 78: ko04380 Osteoclast differentiation

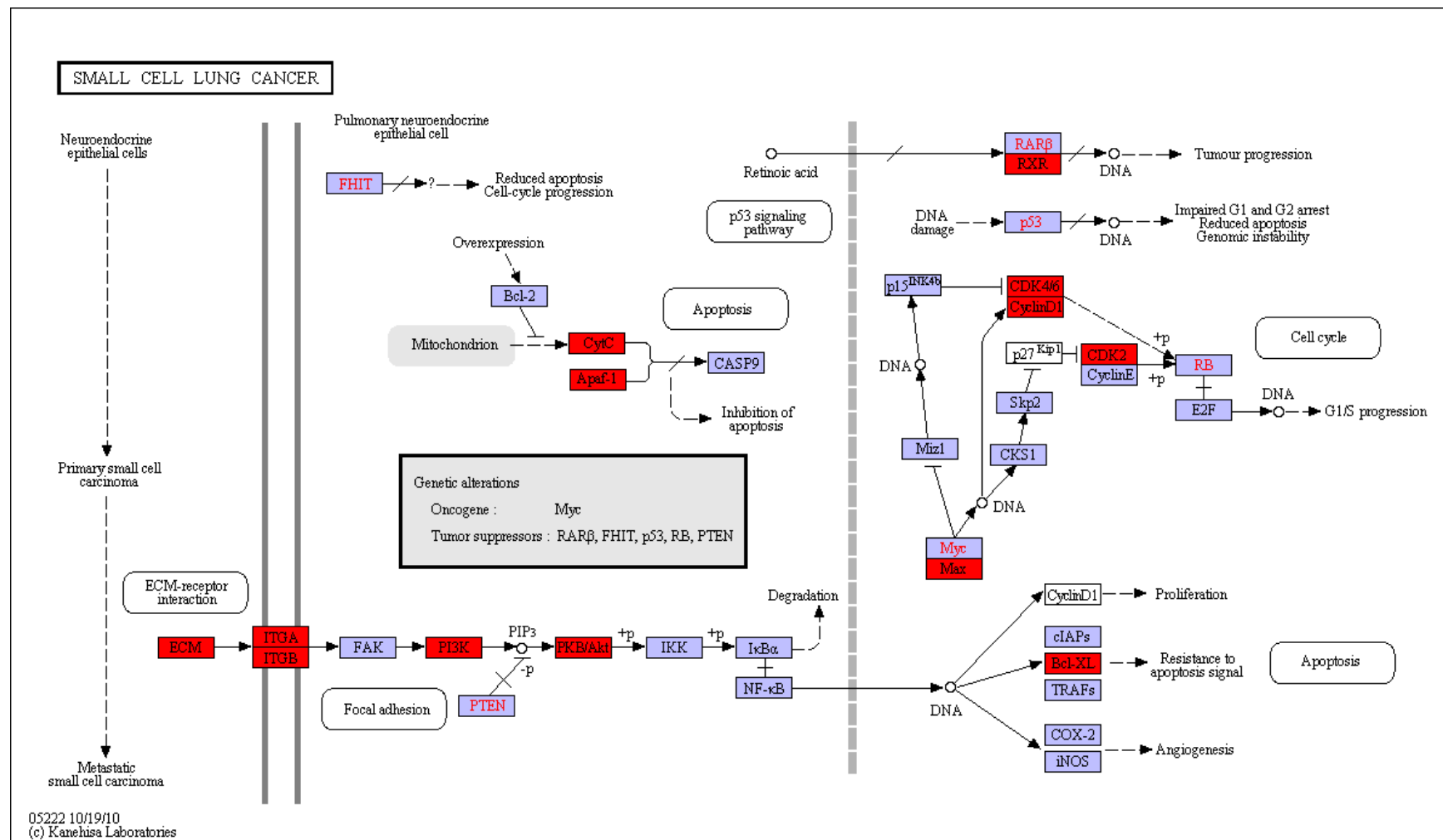

Figure 79: ko05222 Small cell lung cancer



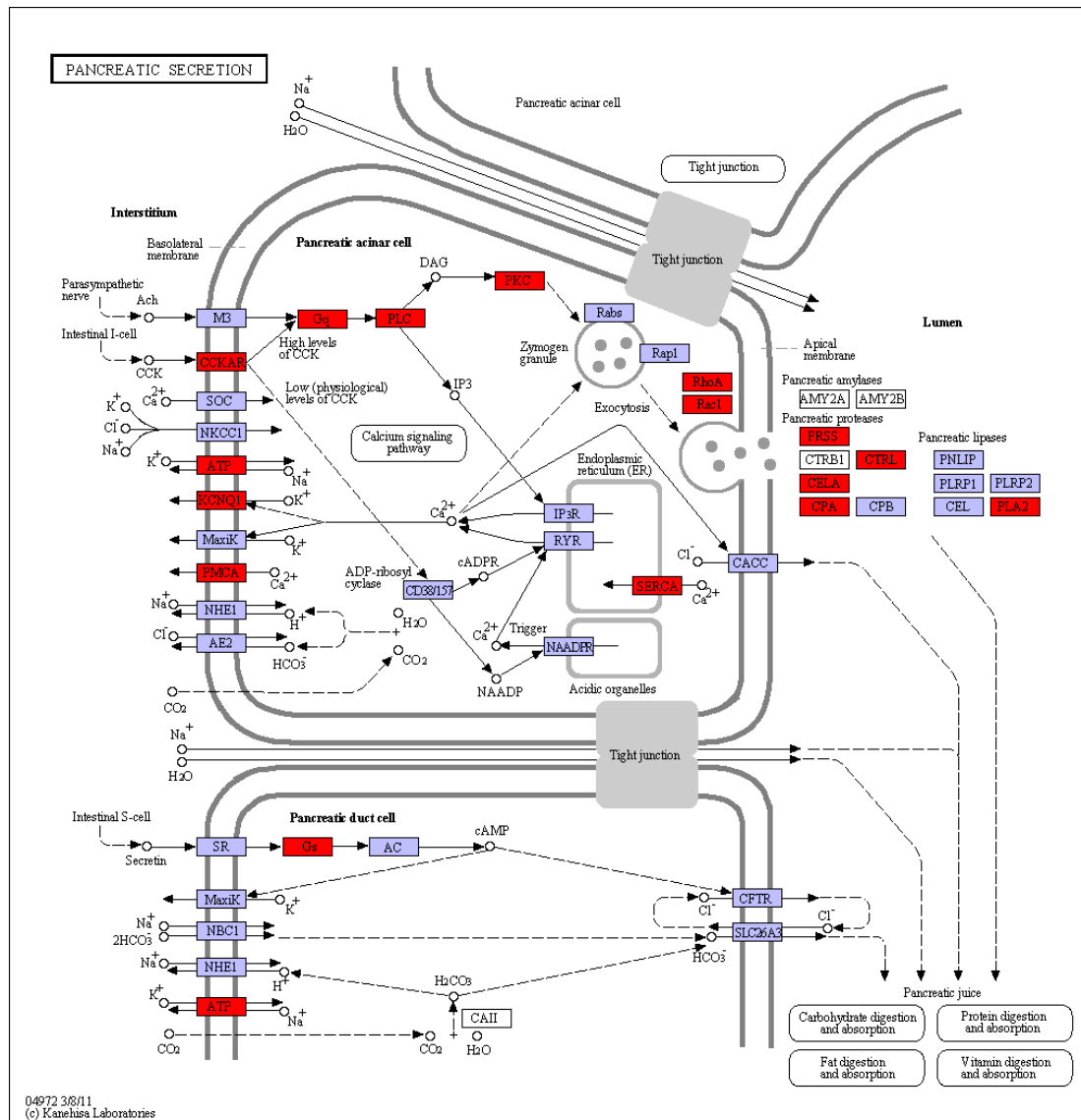

Figure 80: ko04972 Pancreatic secretion

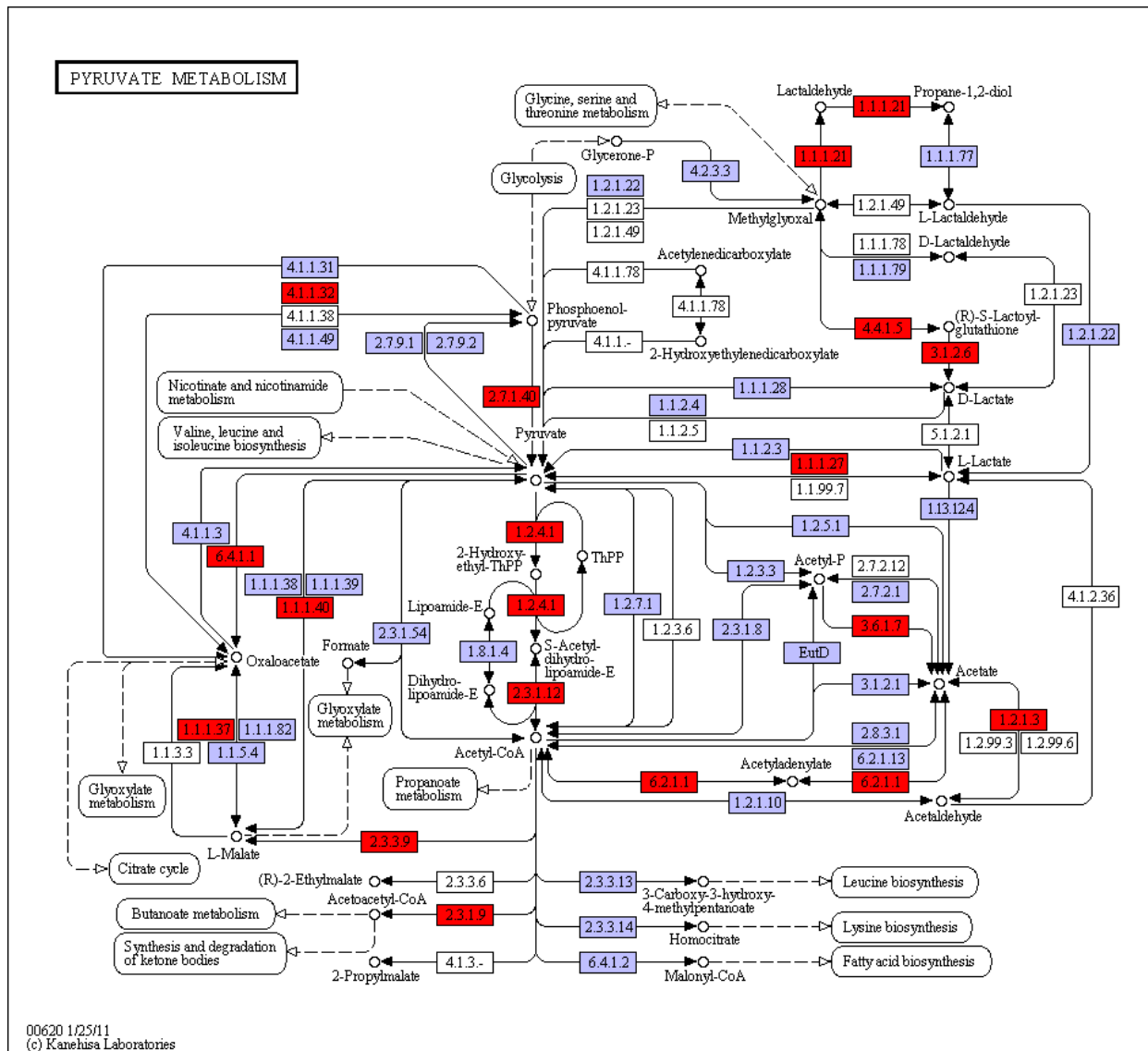

Figure 81: ko00620 Pyruvate metabolism



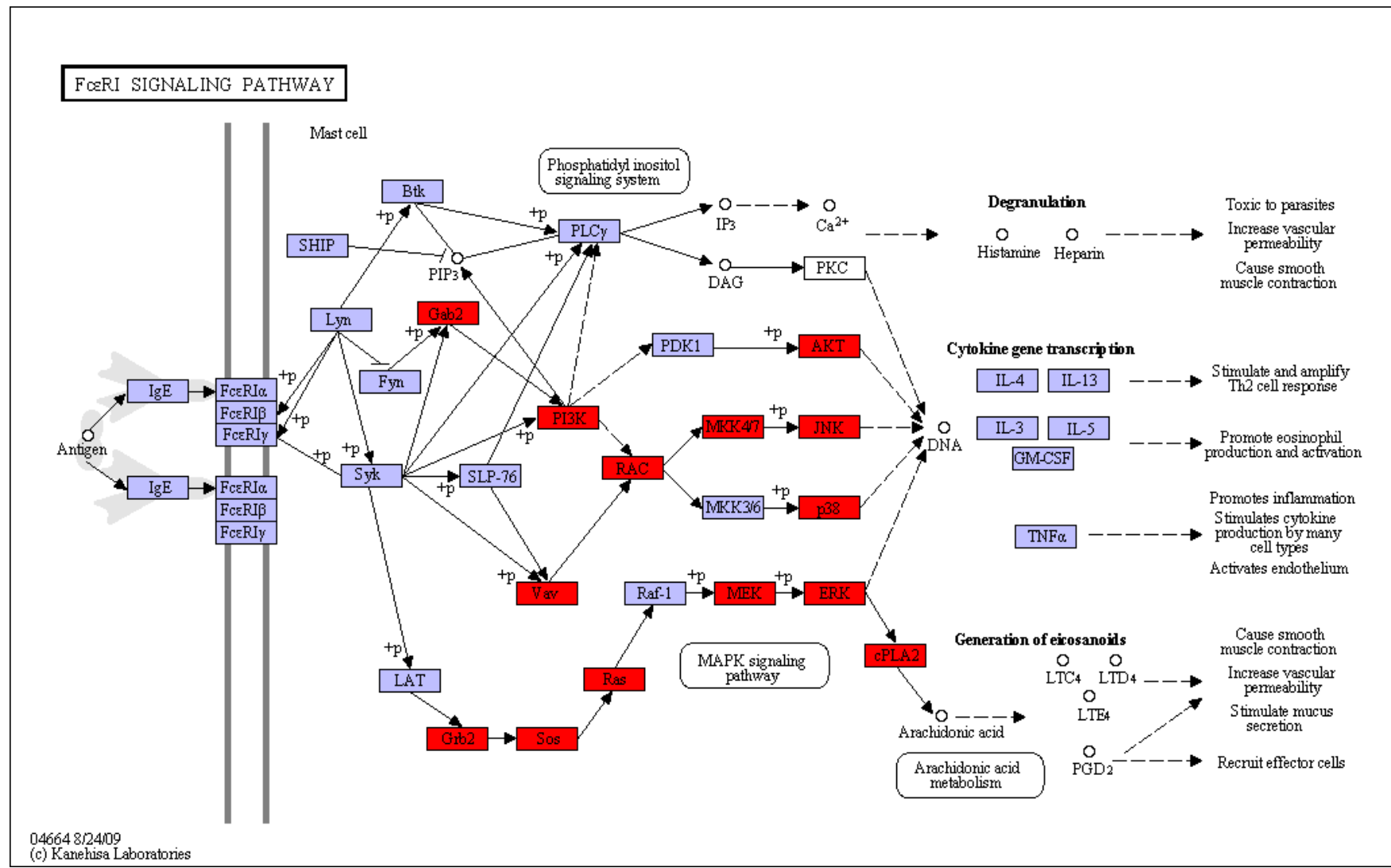

Figure 83: ko04664 Fc epsilon RI signaling pathway

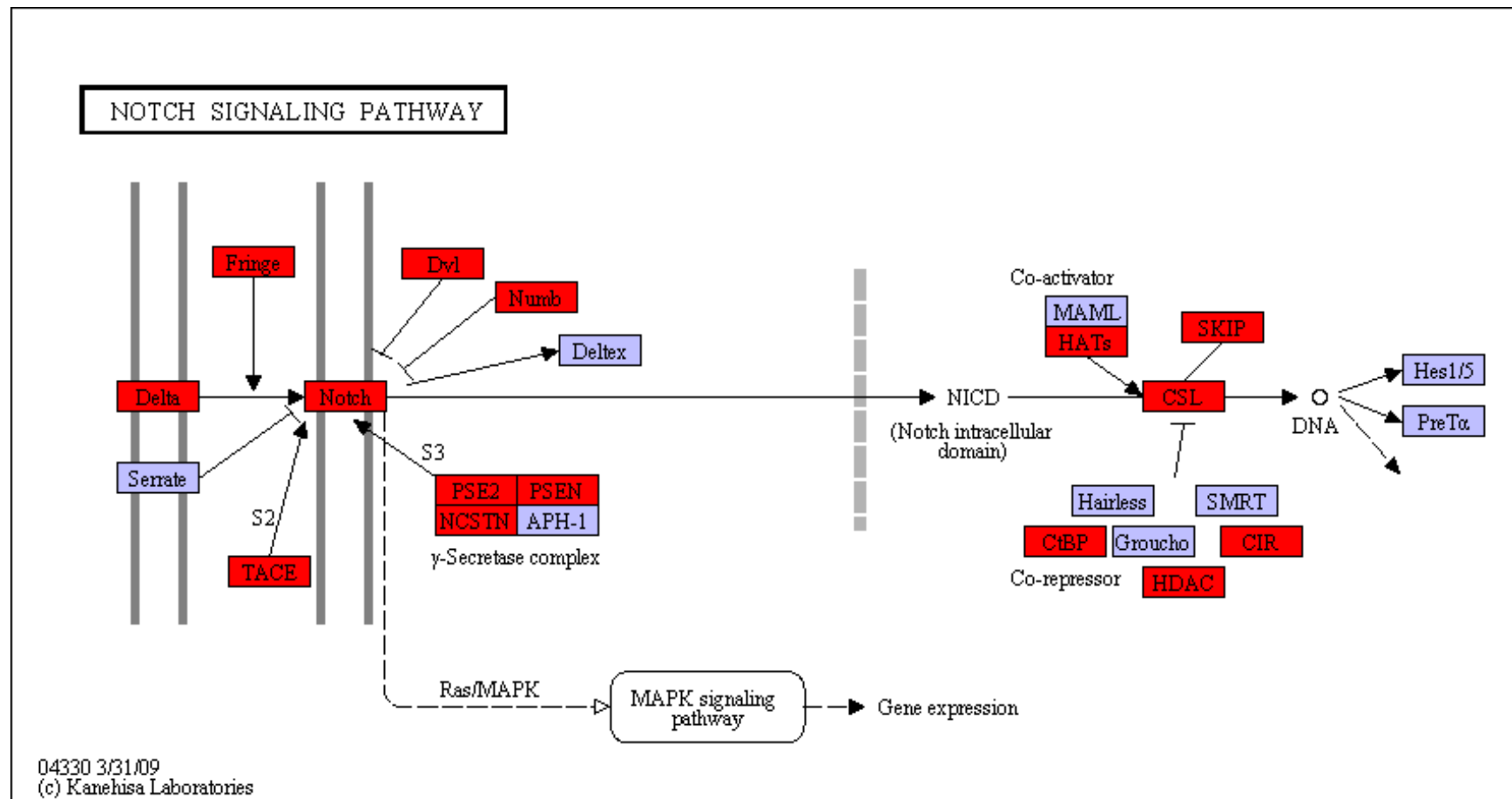

Figure 84: ko04330 Notch signaling pathway

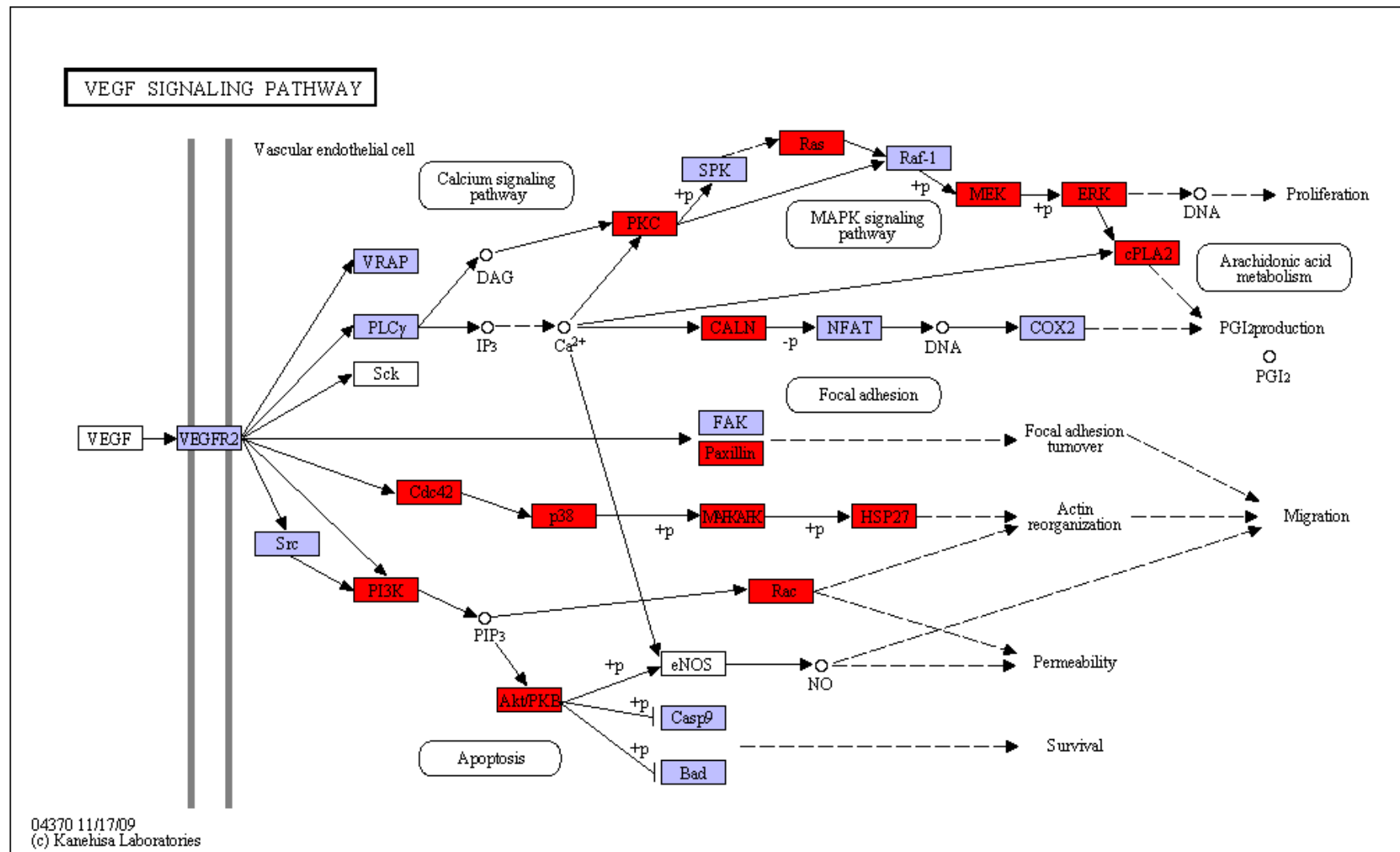

Figure 85: ko04370 VEGF signaling pathway

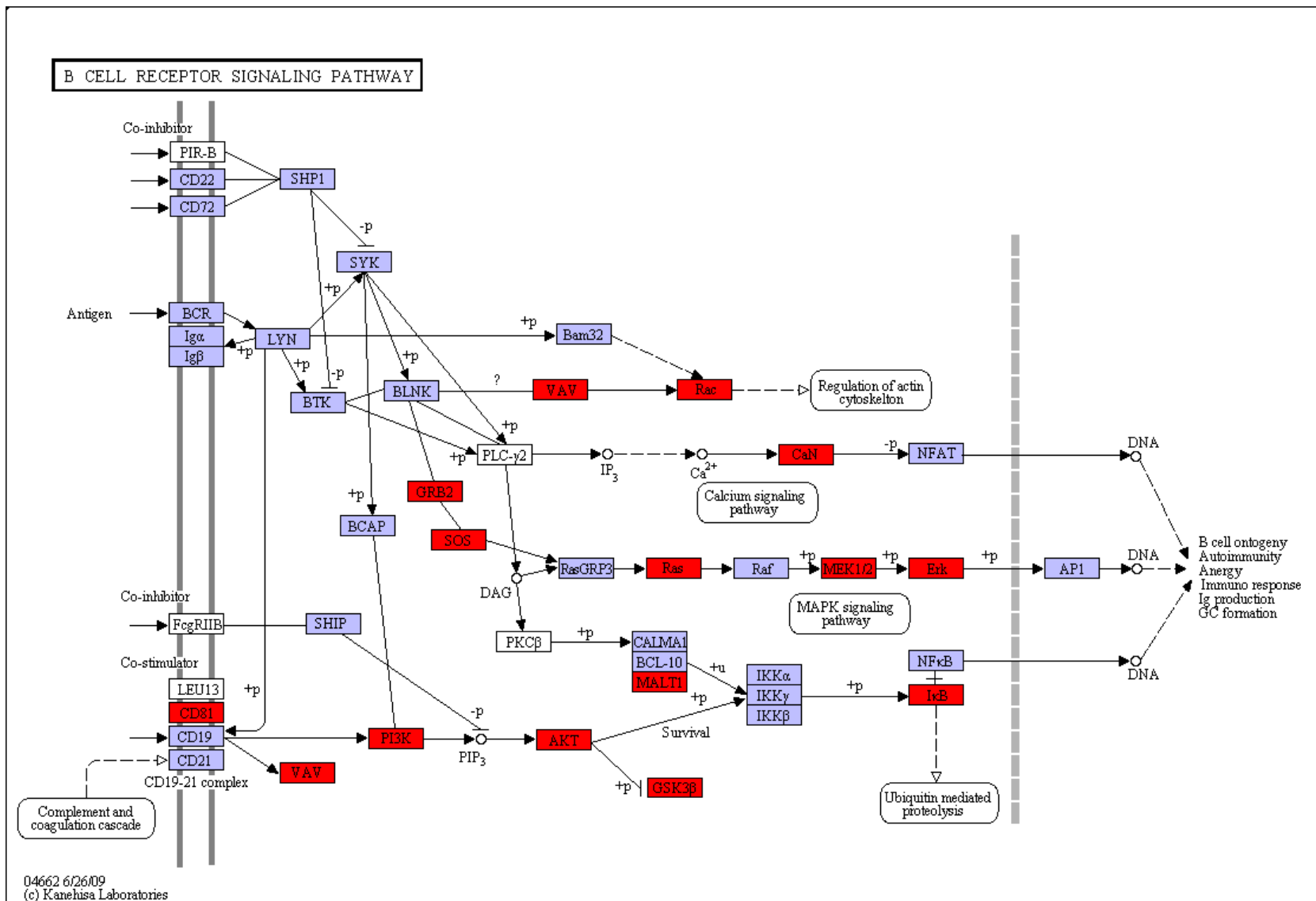

Figure 86: ko04662 B cell receptor signaling pathway

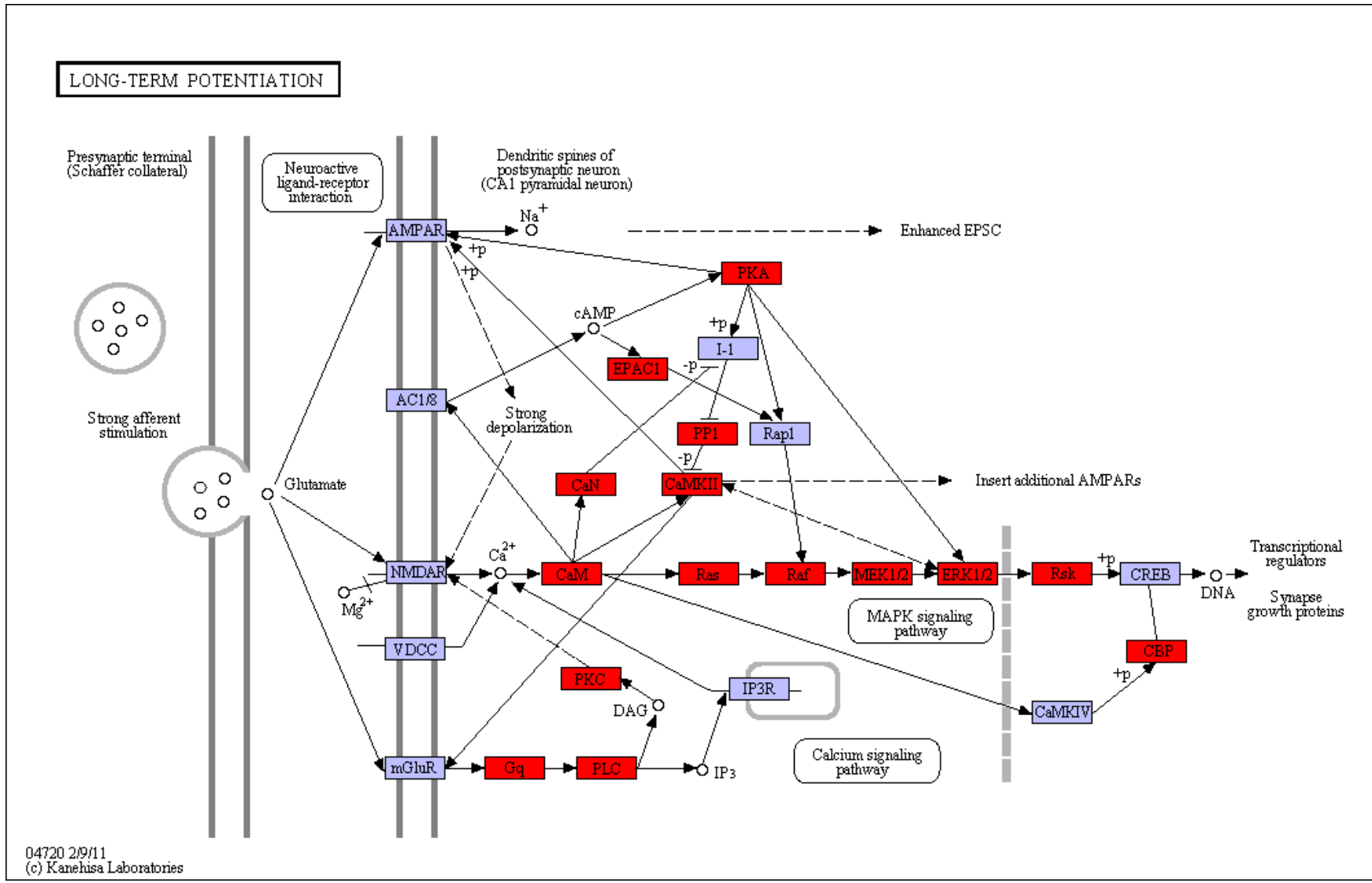

Figure 87: ko04720 Long-term potentiation



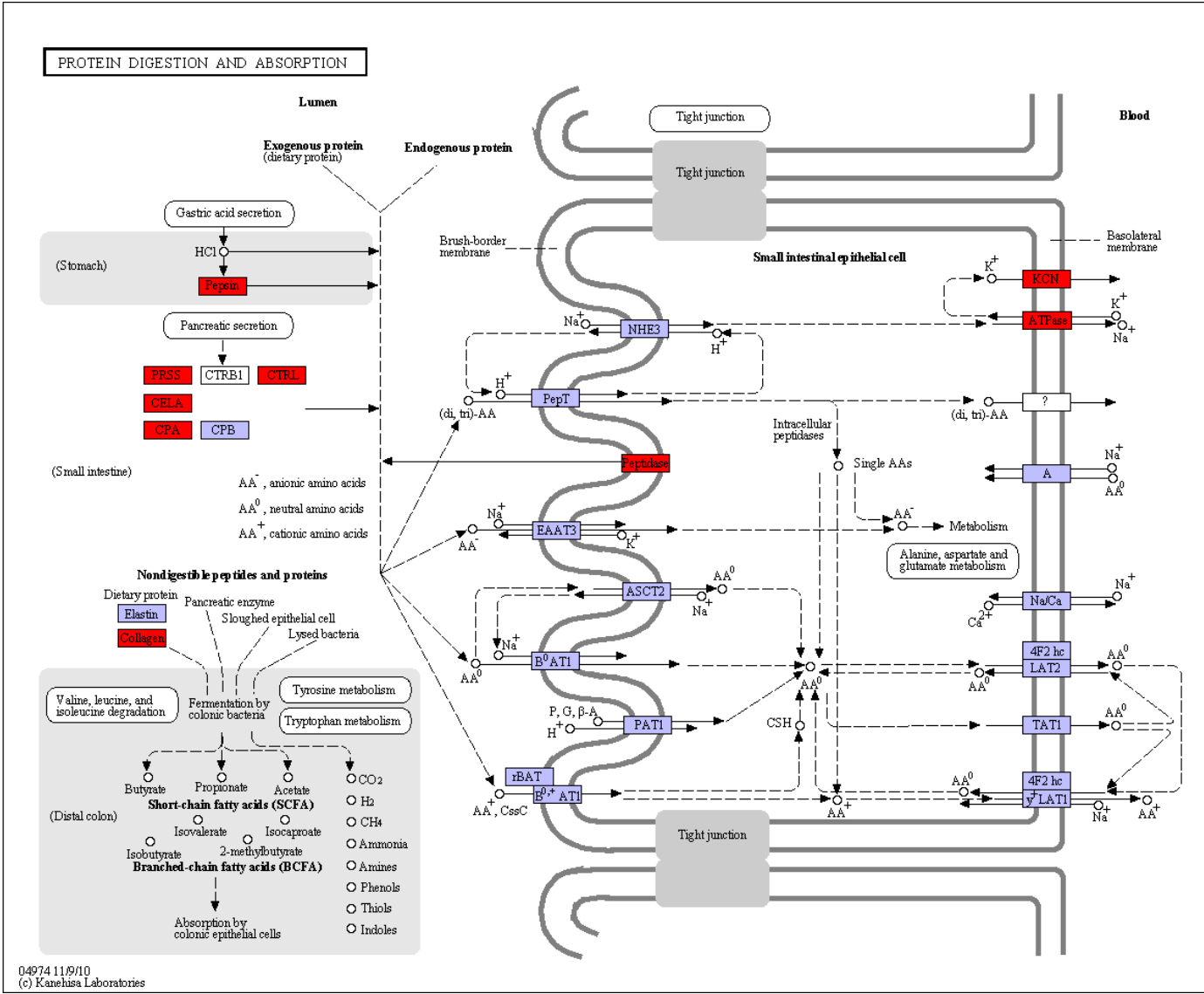

Figure 88: ko04974 Protein digestion and absorption



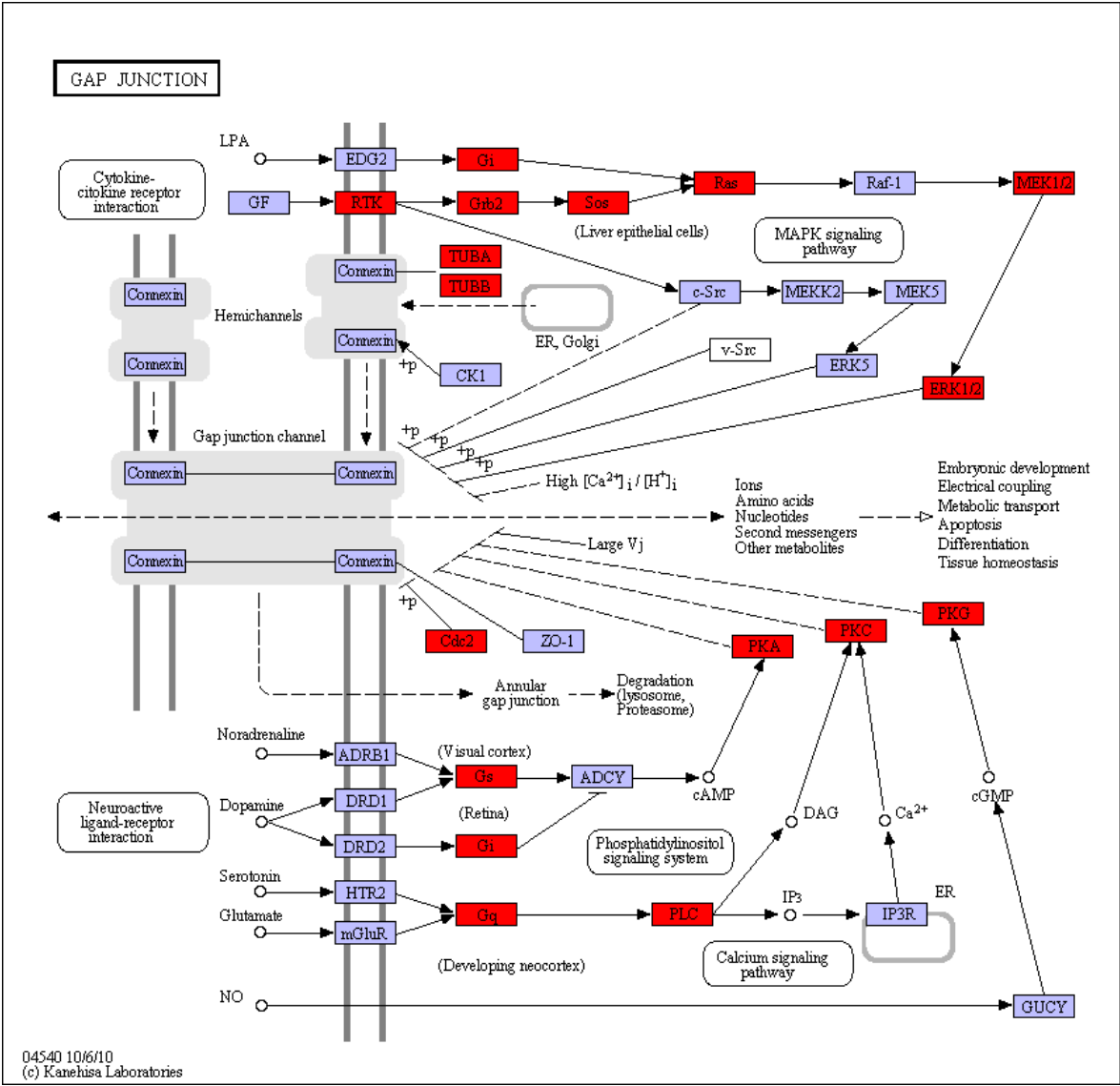

Figure 90: ko04540 Gap junction

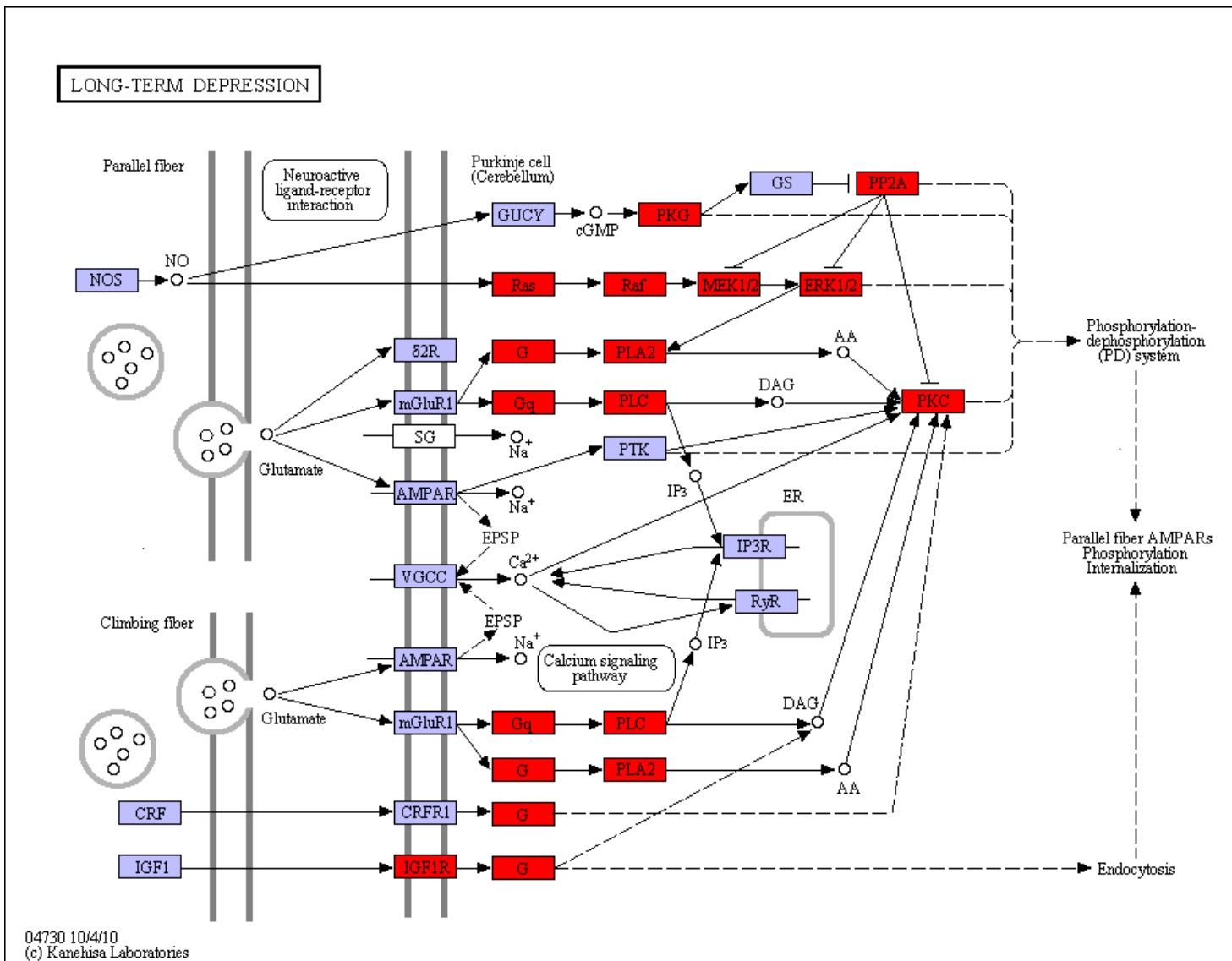

Figure 91: ko04730 Long-term depression

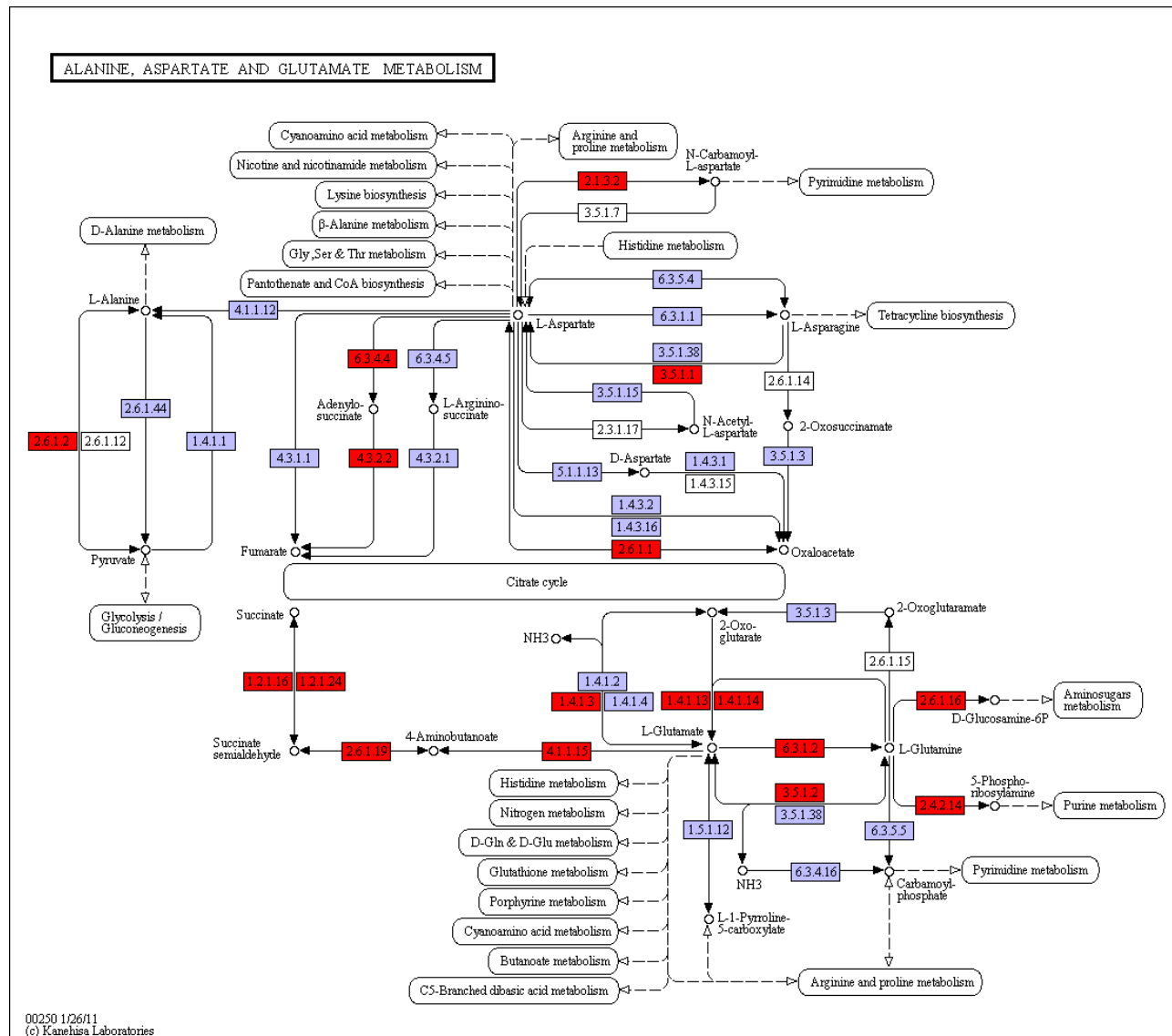

Figure 92: ko00250 Alanine, aspartate and glutamate metabolism

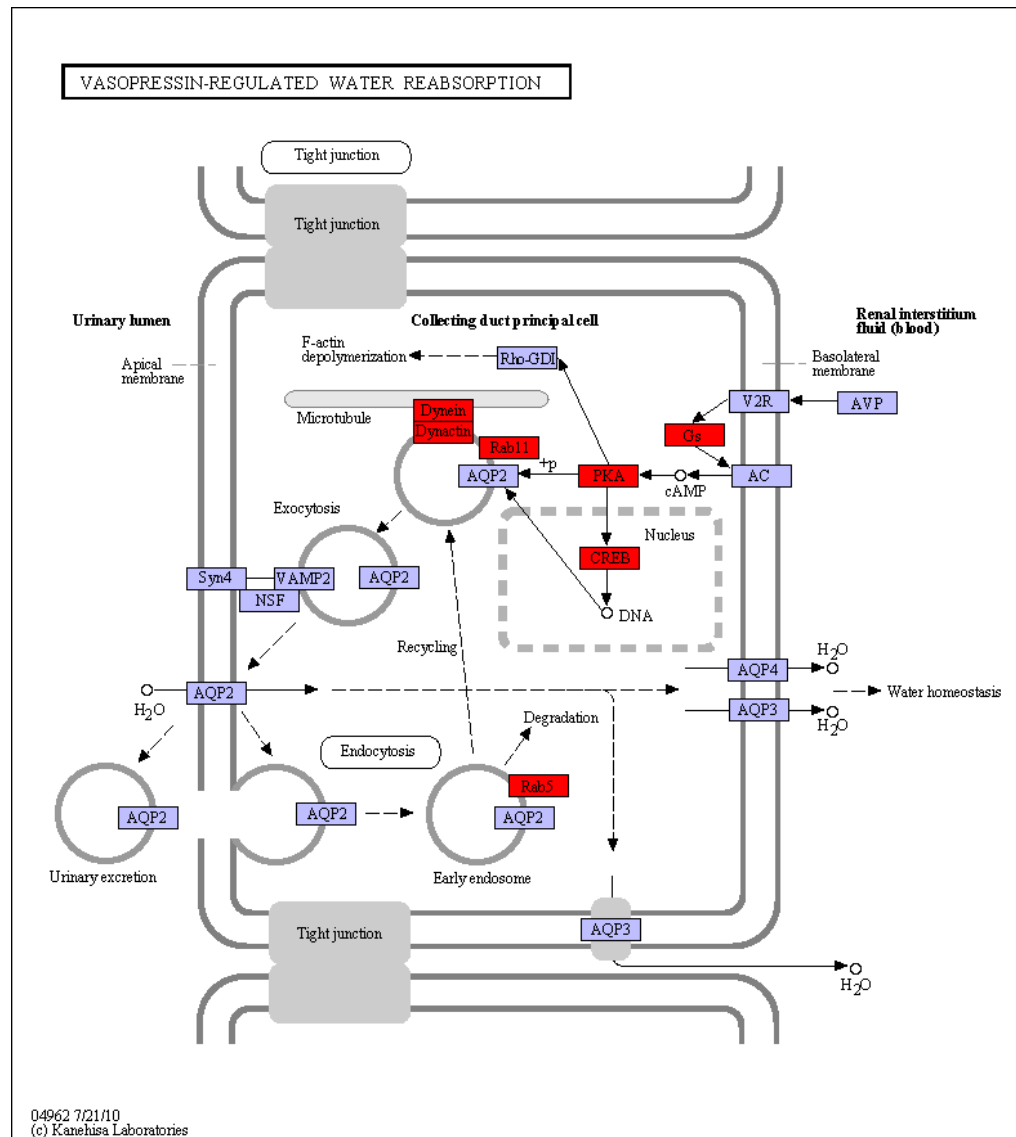

Figure 93: ko04962 Vasopressin-regulated water reabsorption

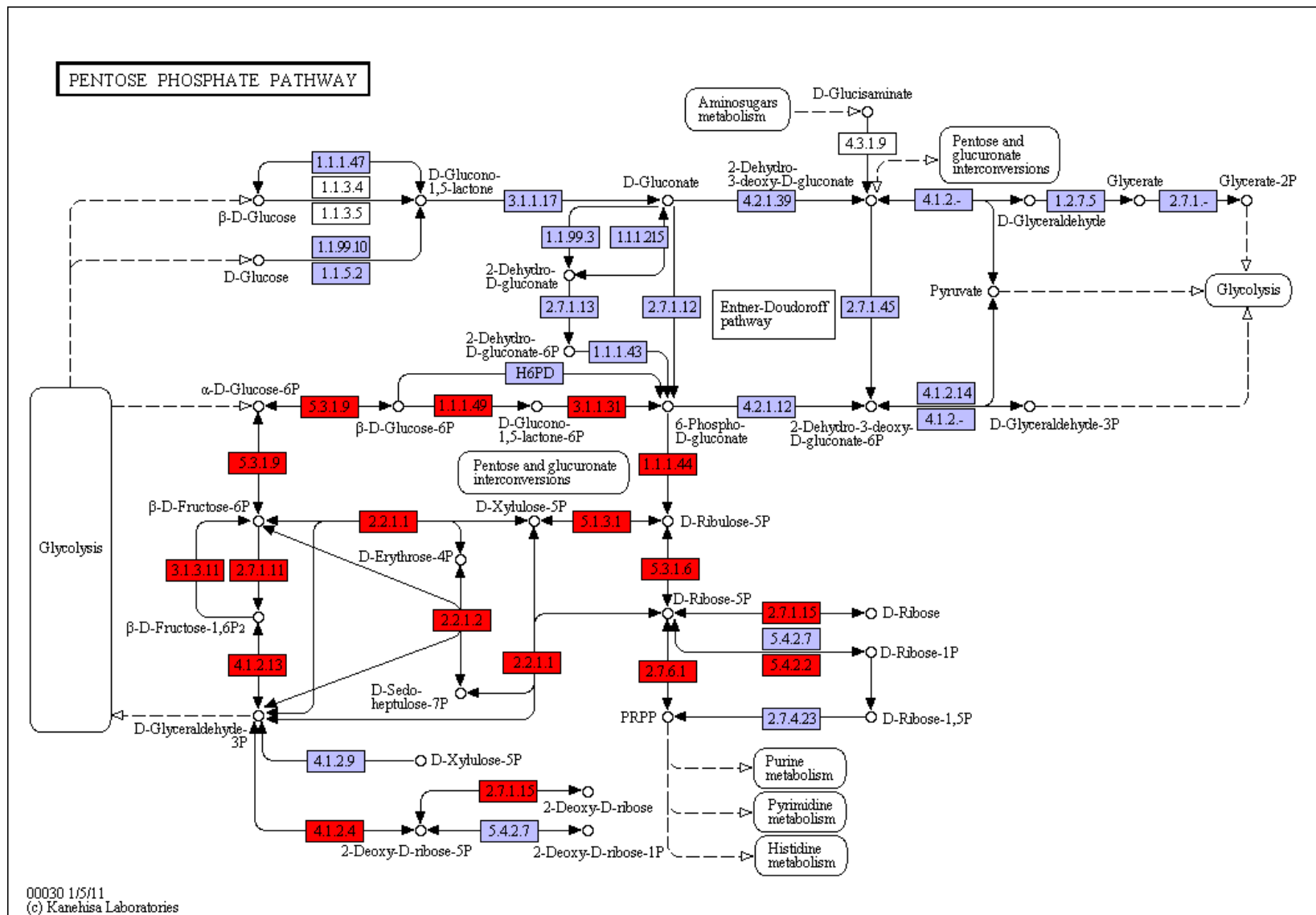

Figure 94: ko00030 Pentose phosphate pathway







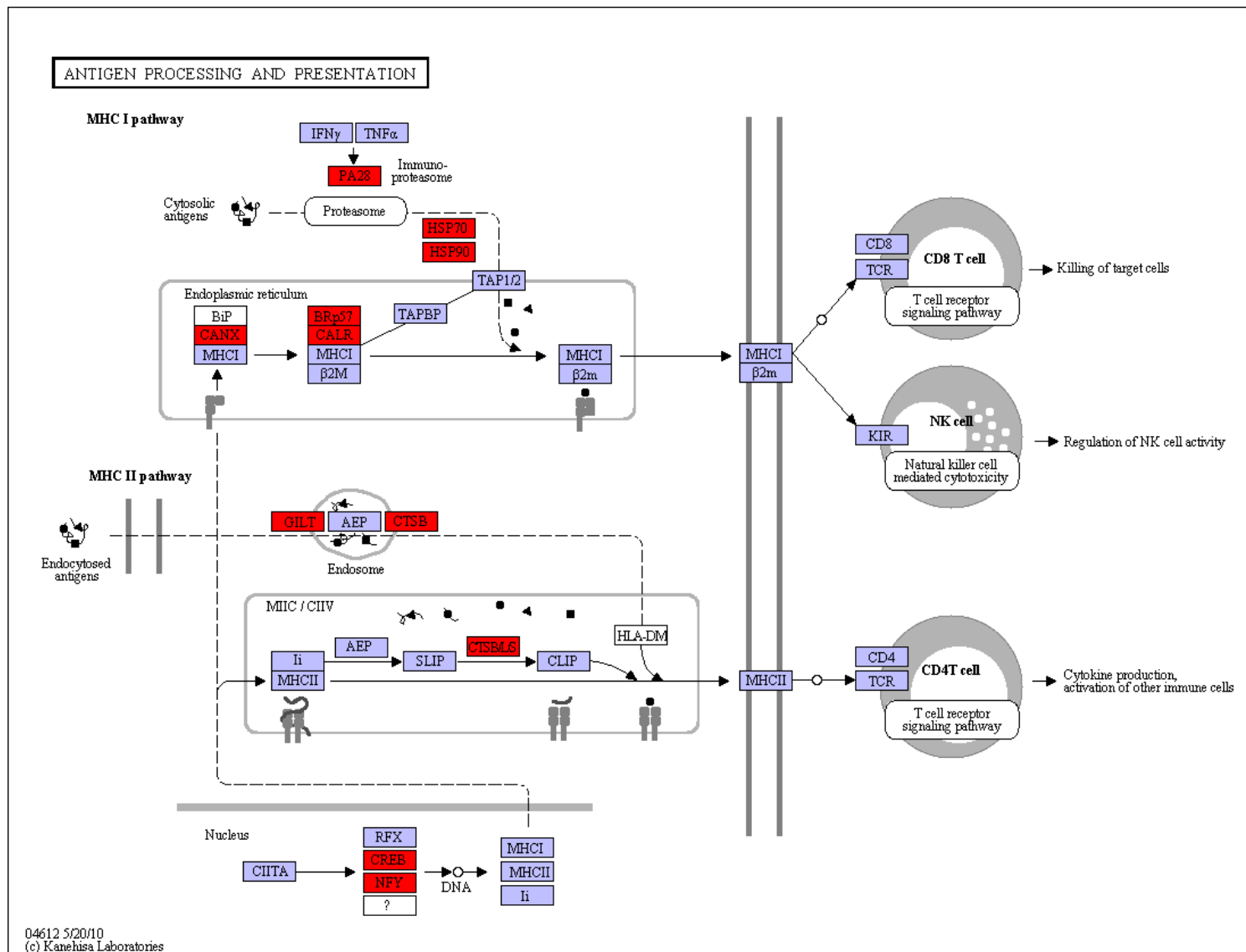

Figure 97: ko04612 Antigen processing and presentation

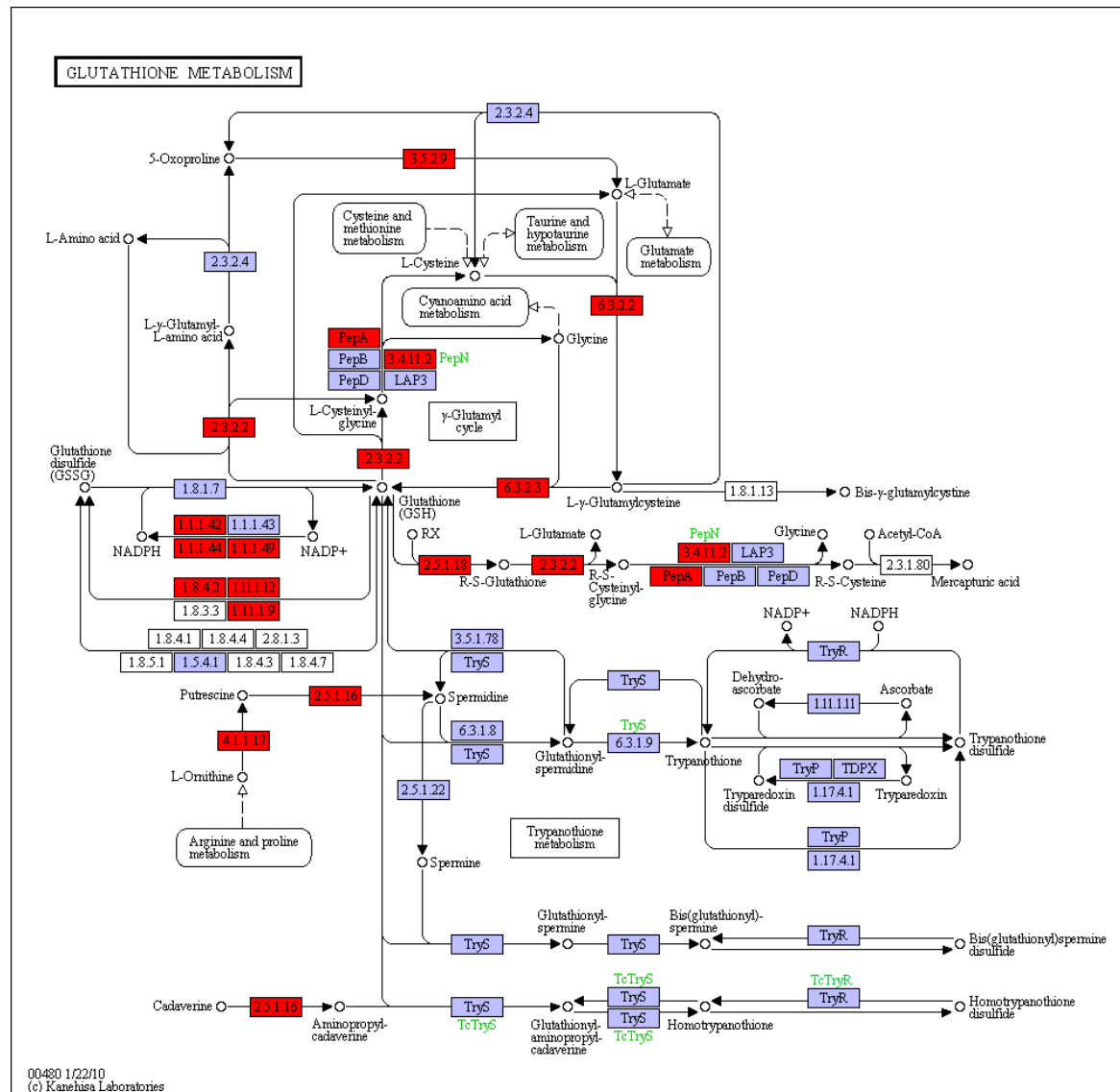

Figure 98: ko00480 Glutathione metabolism

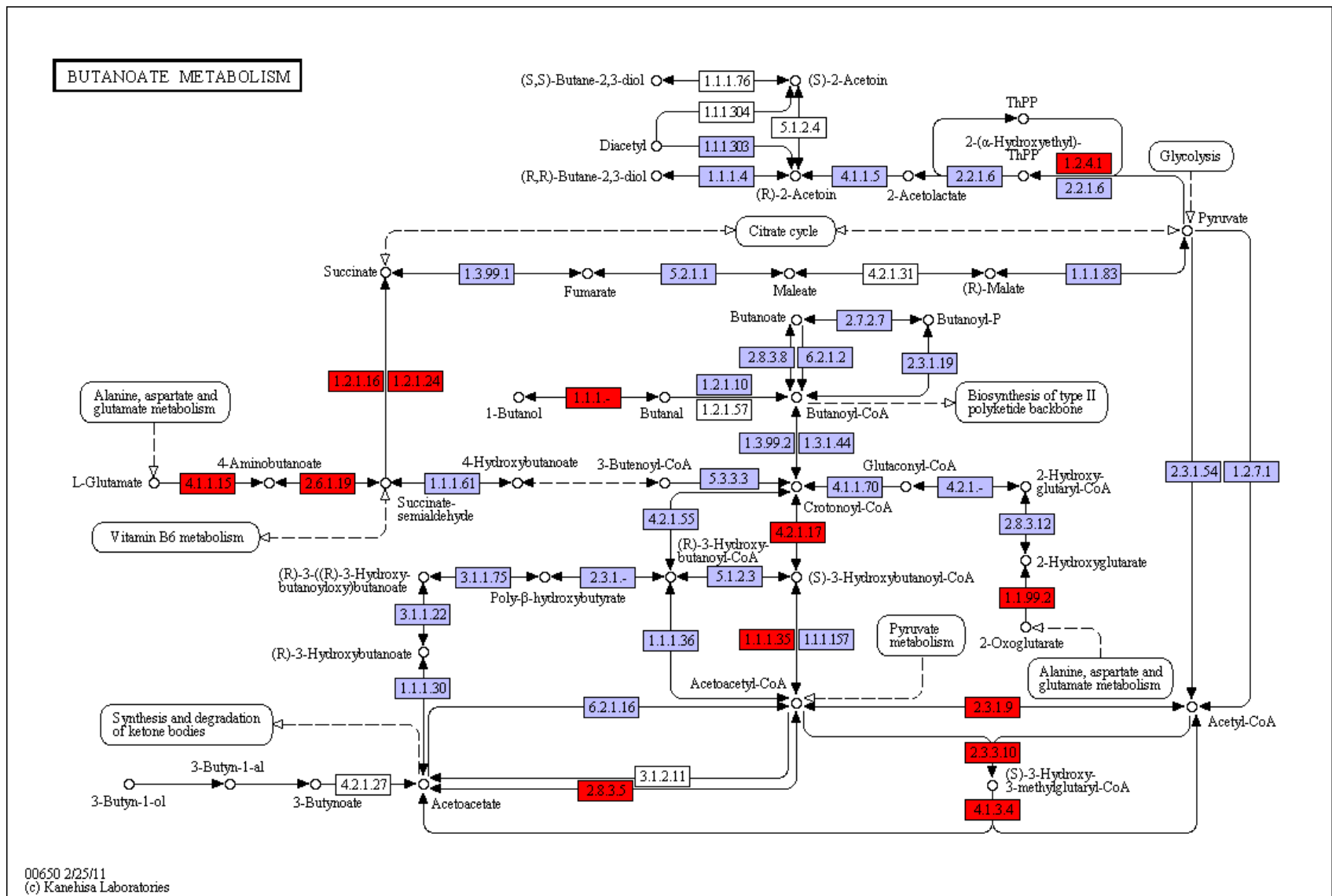

Figure 99: ko00650 Butanoate metabolism

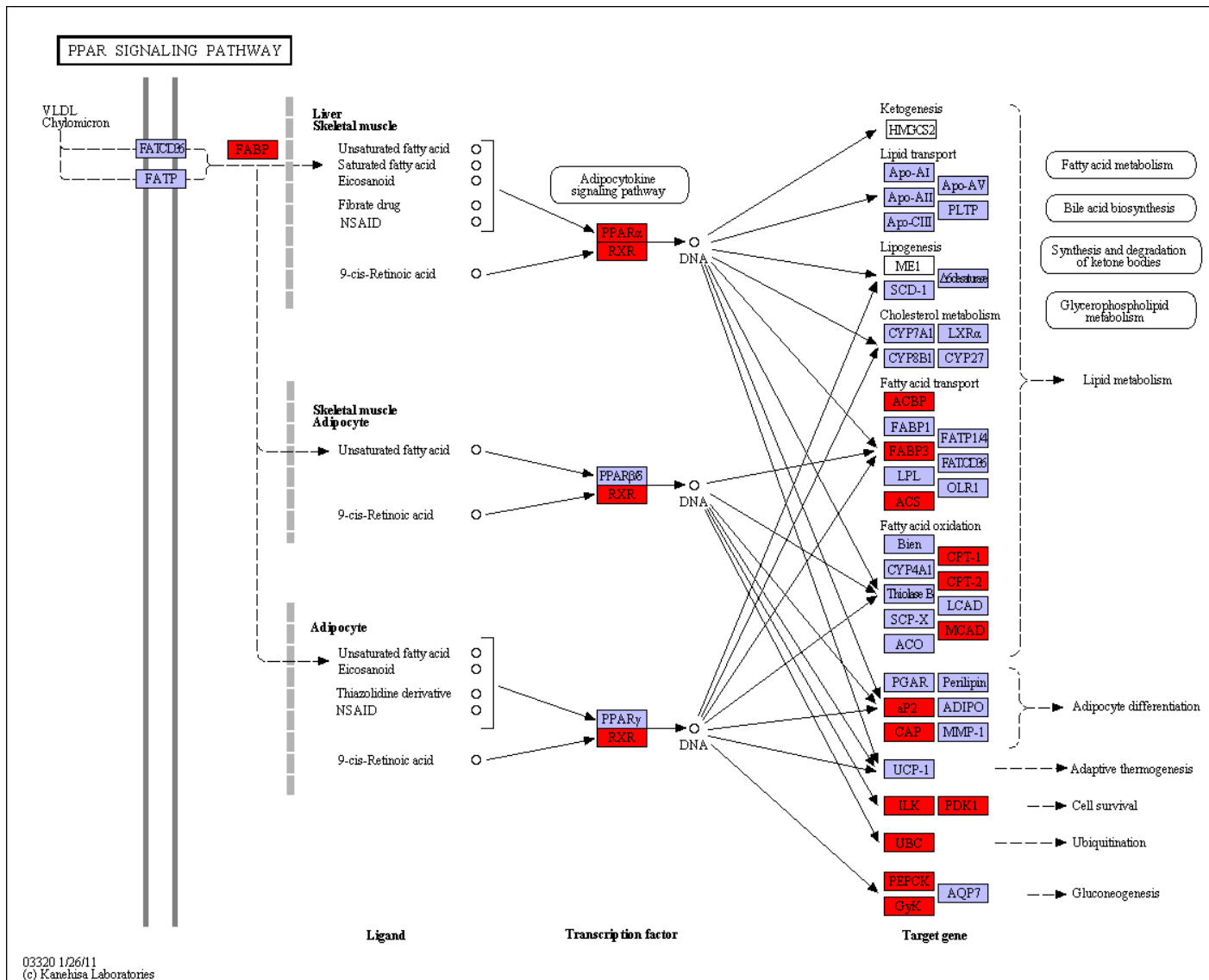

Figure 100: ko03320 PPAR signaling pathway

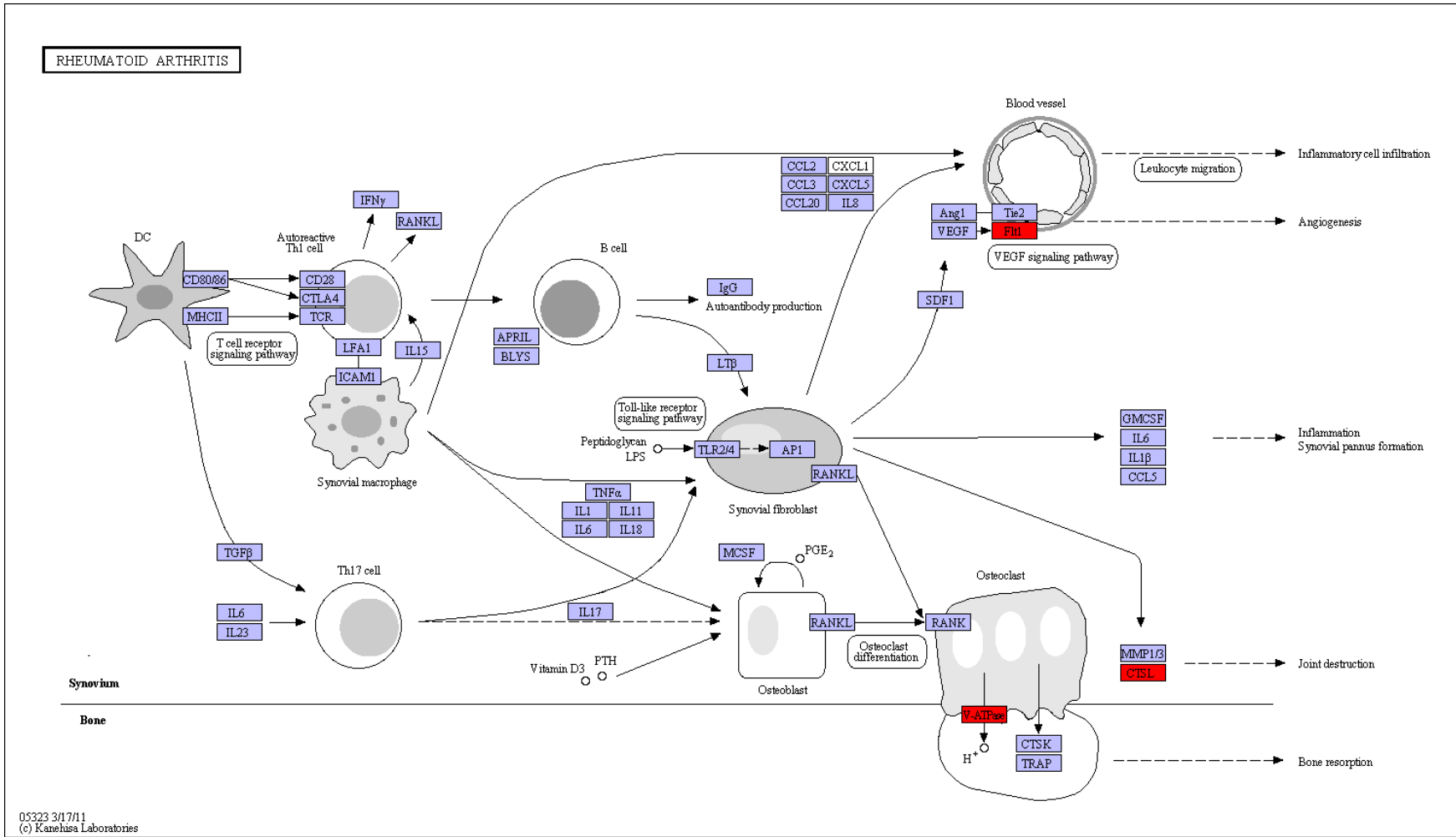

Figure 101: ko05323 Rheumatoid arthritis

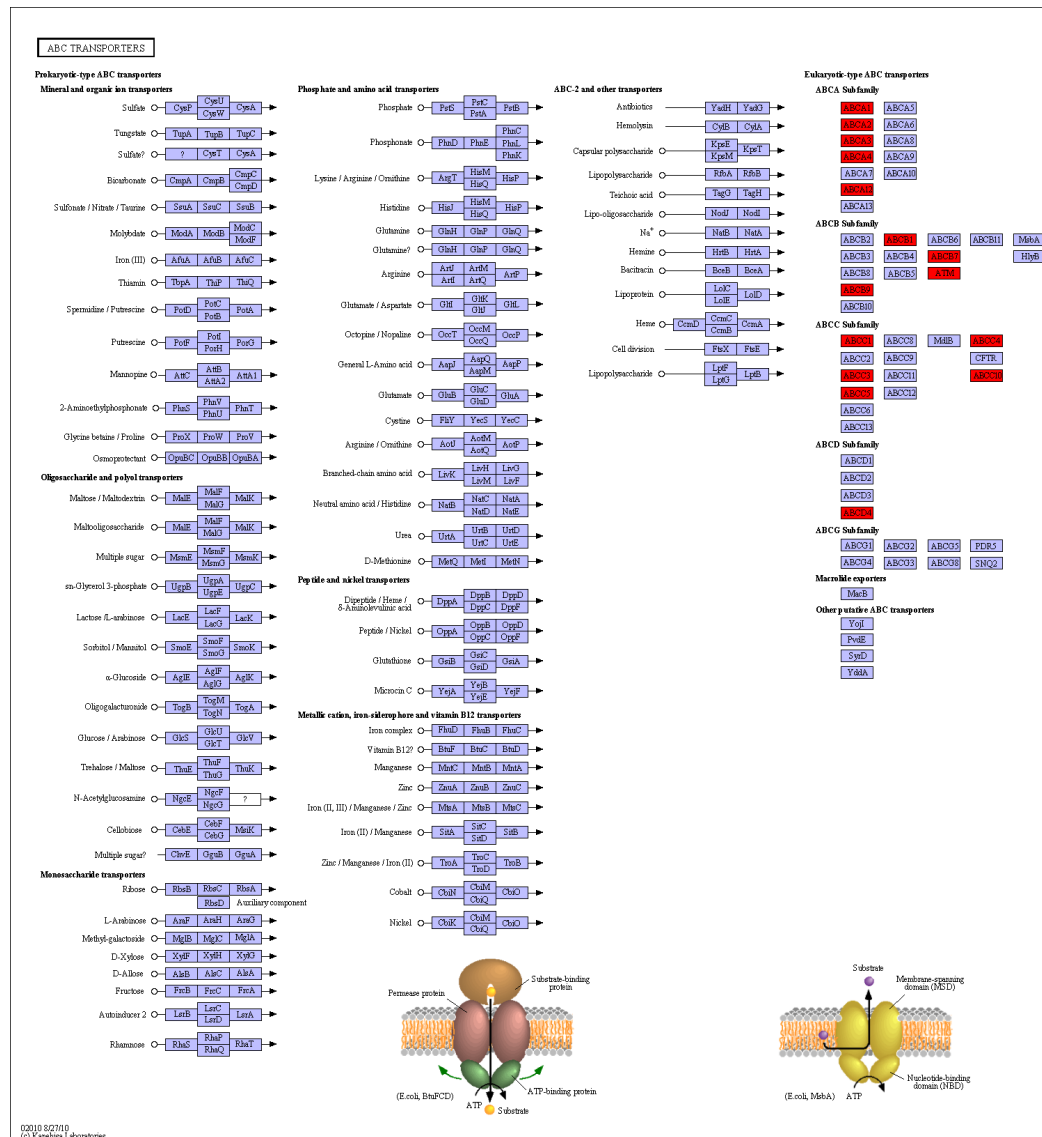

Figure 102: ko02010 ABC transporters

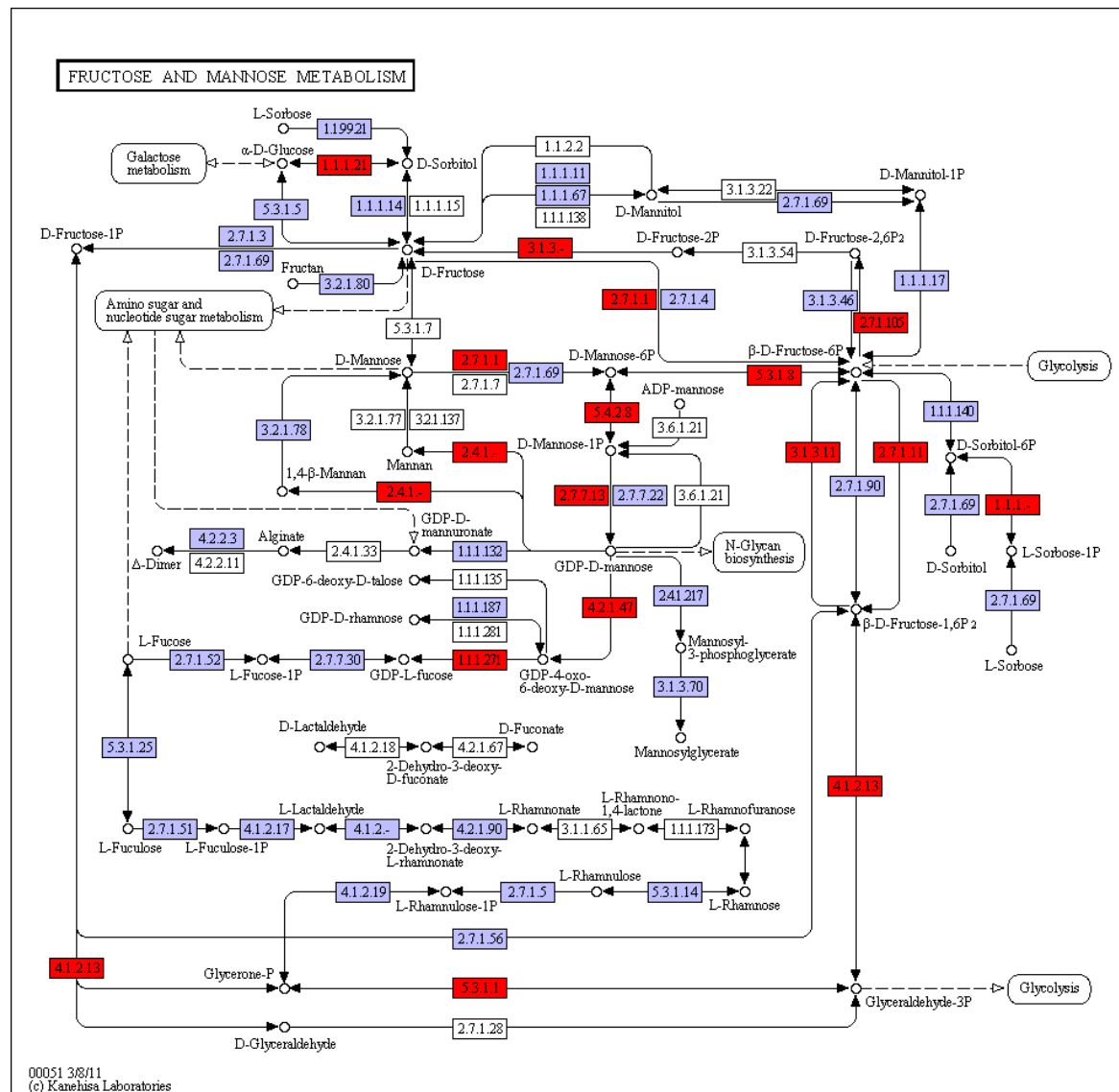

Figure 103: ko00051 Fructose and mannose metabolism



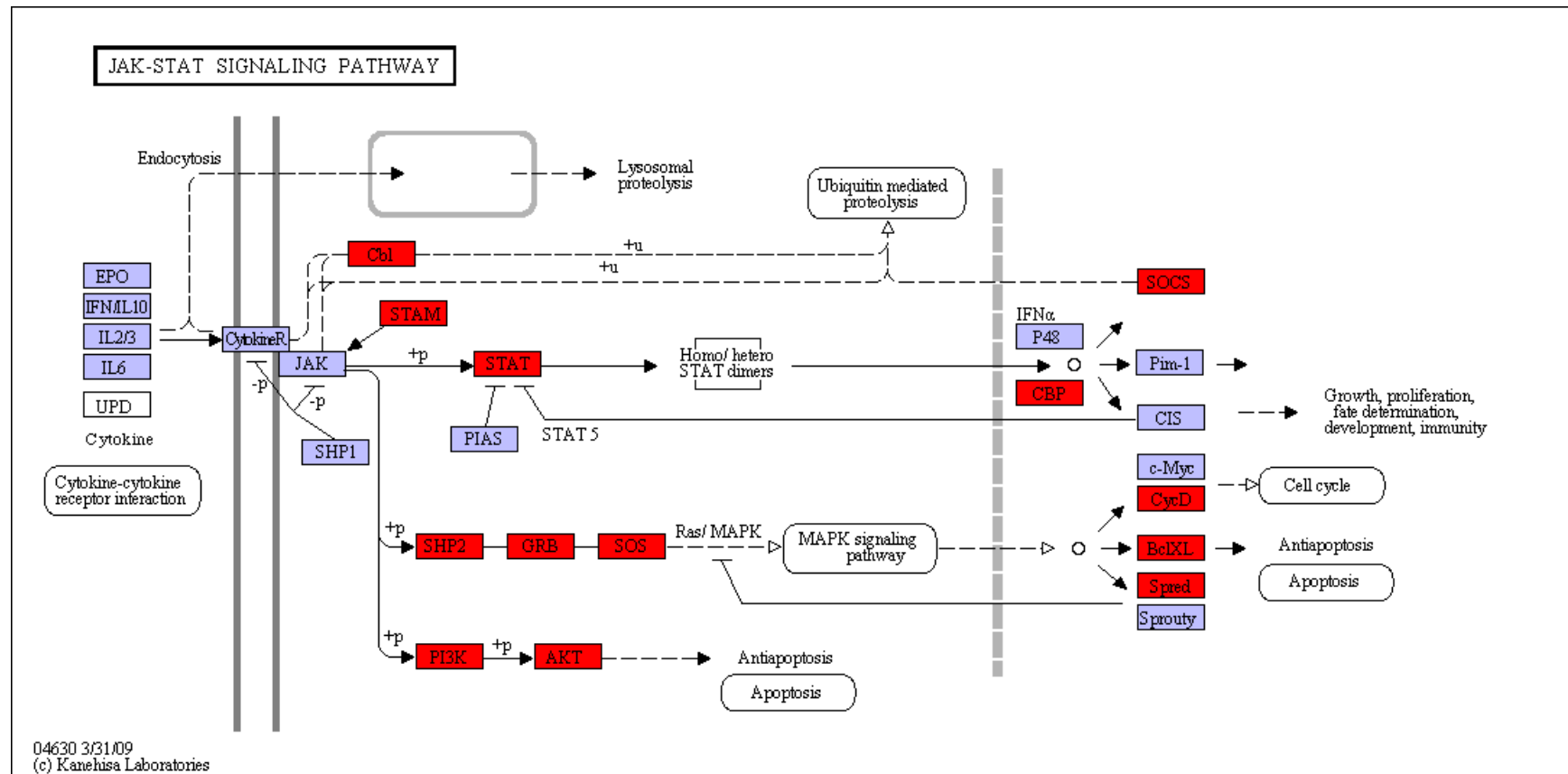

Figure 104: ko04630 Jak-STAT signaling pathway

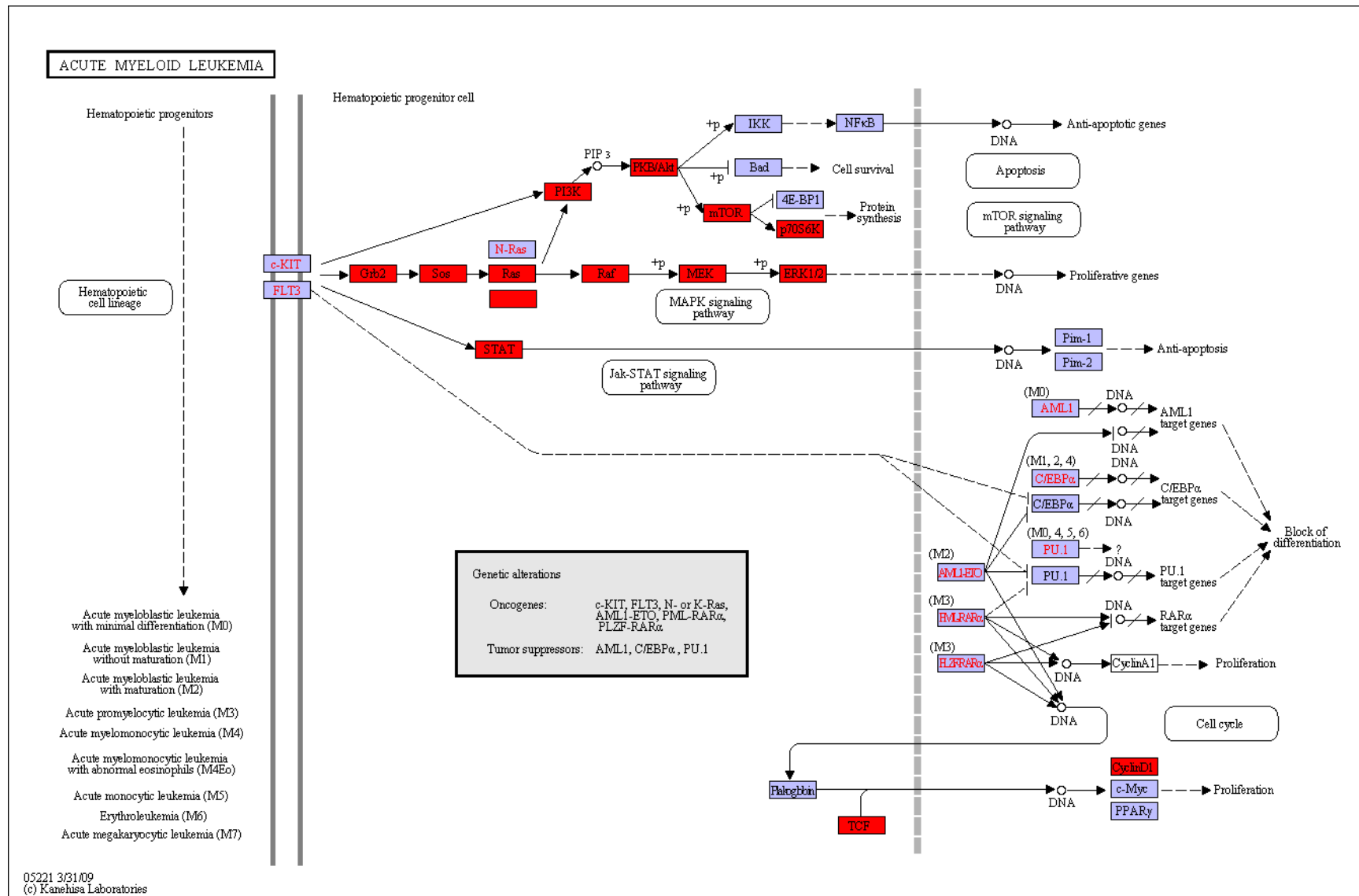

Figure 105: ko05221 Acute myeloid leukemia

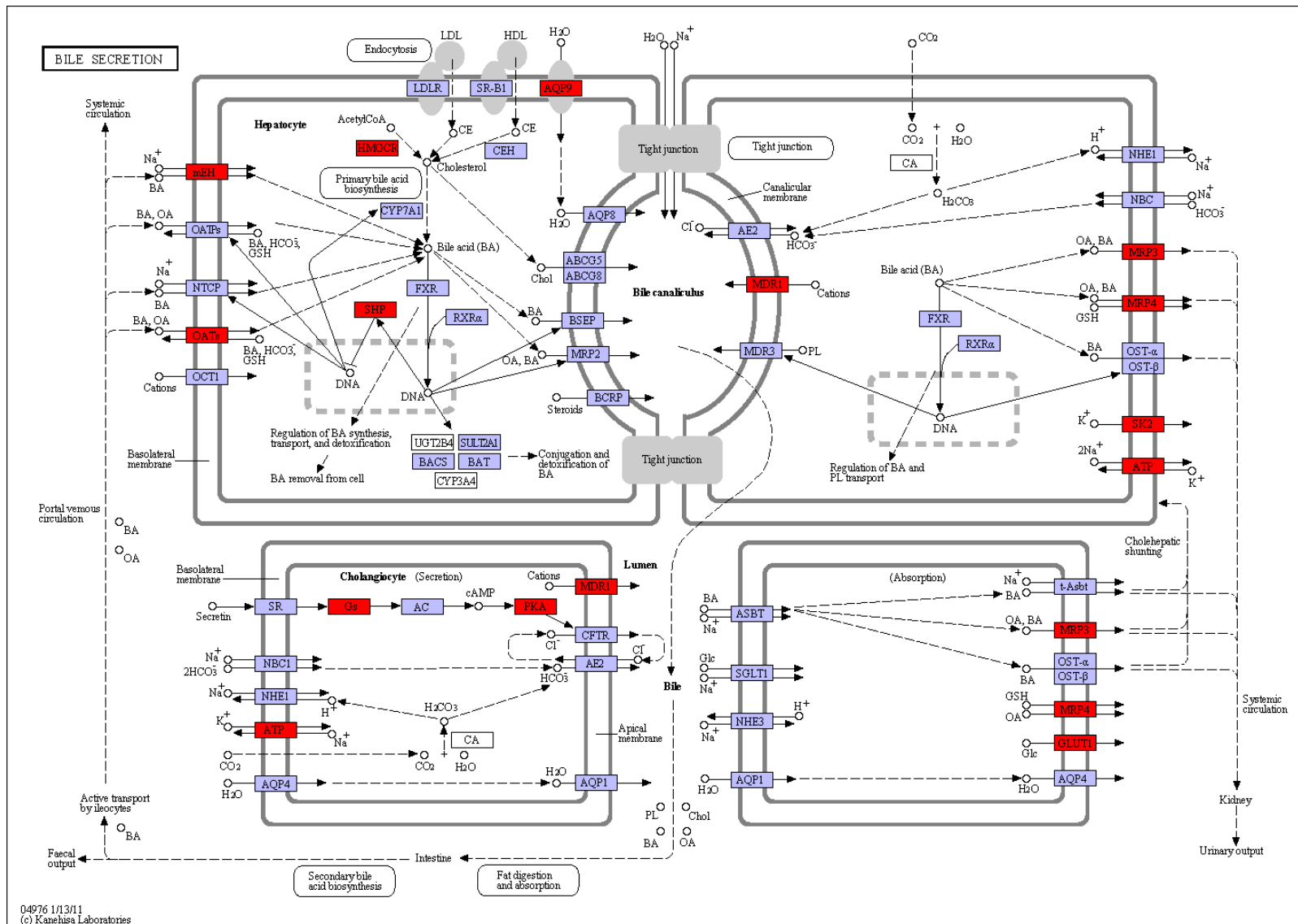

Figure 106: ko04976 Bile secretion

**PROTEIN EXPORT**

**Sec dependent pathway**

Prokaryotic type

Translocation channel and related proteins

SecY SecE SecG

SecD/F YajC

YidC

SecA SecB SecM

SRP

Ffh Ffs

SRP receptor

FtsY

Eukaryotic type

SEC61 $\alpha$  SEC61 $\beta$  SEC61 $\gamma$

SEC62 SEC63

BiP

SRP9 SRP72 SRP19 RN7SL

SRP14 SRP68 SRP54

SRPR

SRPRB

**Tat (twin-arginine translocation) system**

Prokaryotic type

TatA TatB TatC

TatE

**Signal peptidase**

Prokaryotic type

SPase I SPase II

Eukaryotic type

SPCS1 SPCS2 SPCS3 SEC11

IMP1 IMP2

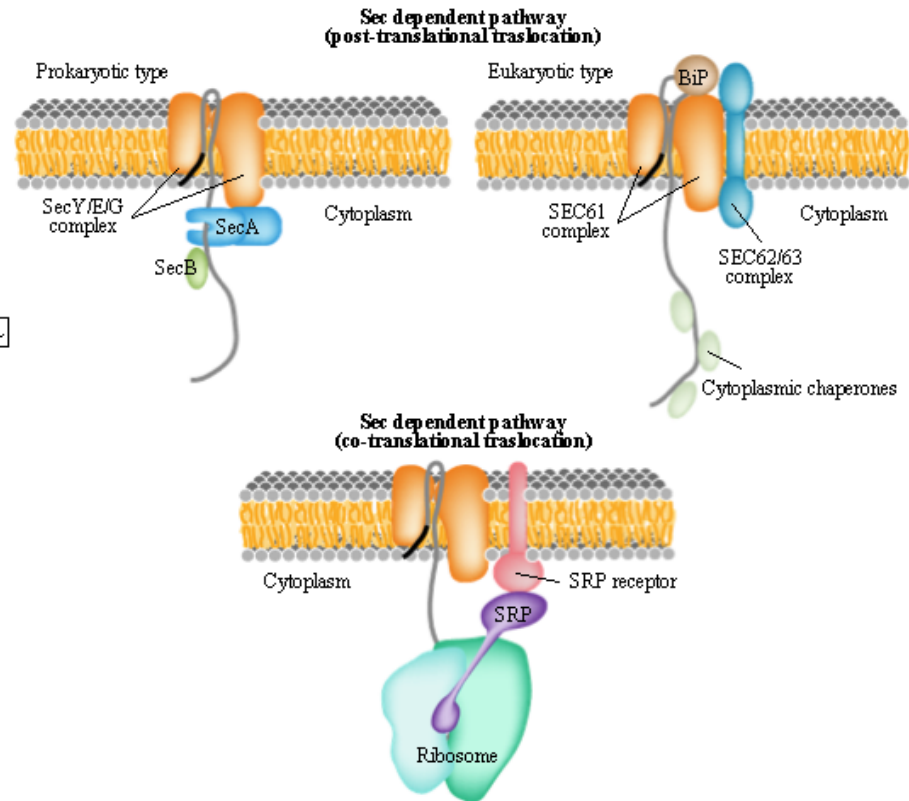

Figure 107: ko03060 Protein export

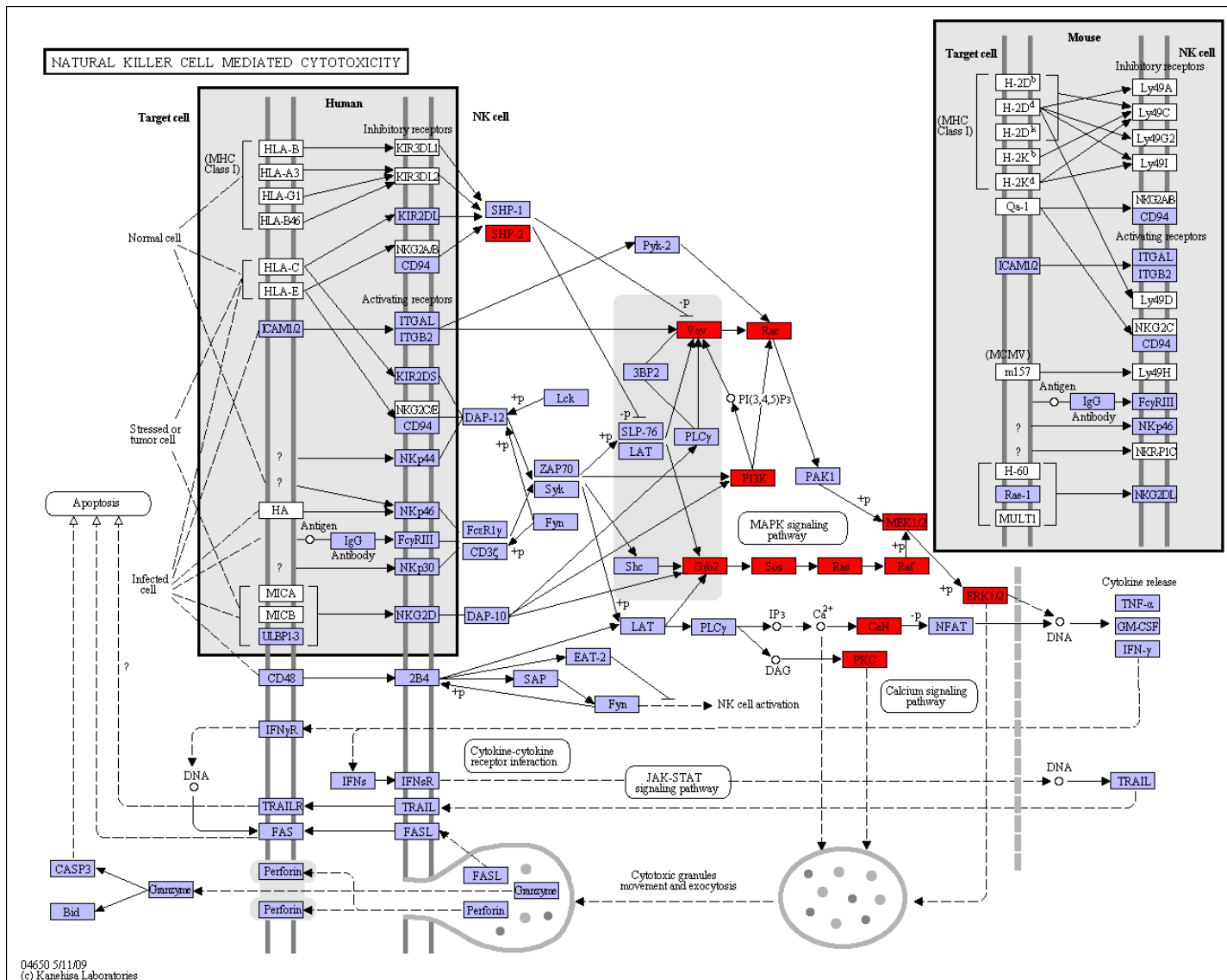

Figure 108: ko04650 Natural killer cell mediated cytotoxicity

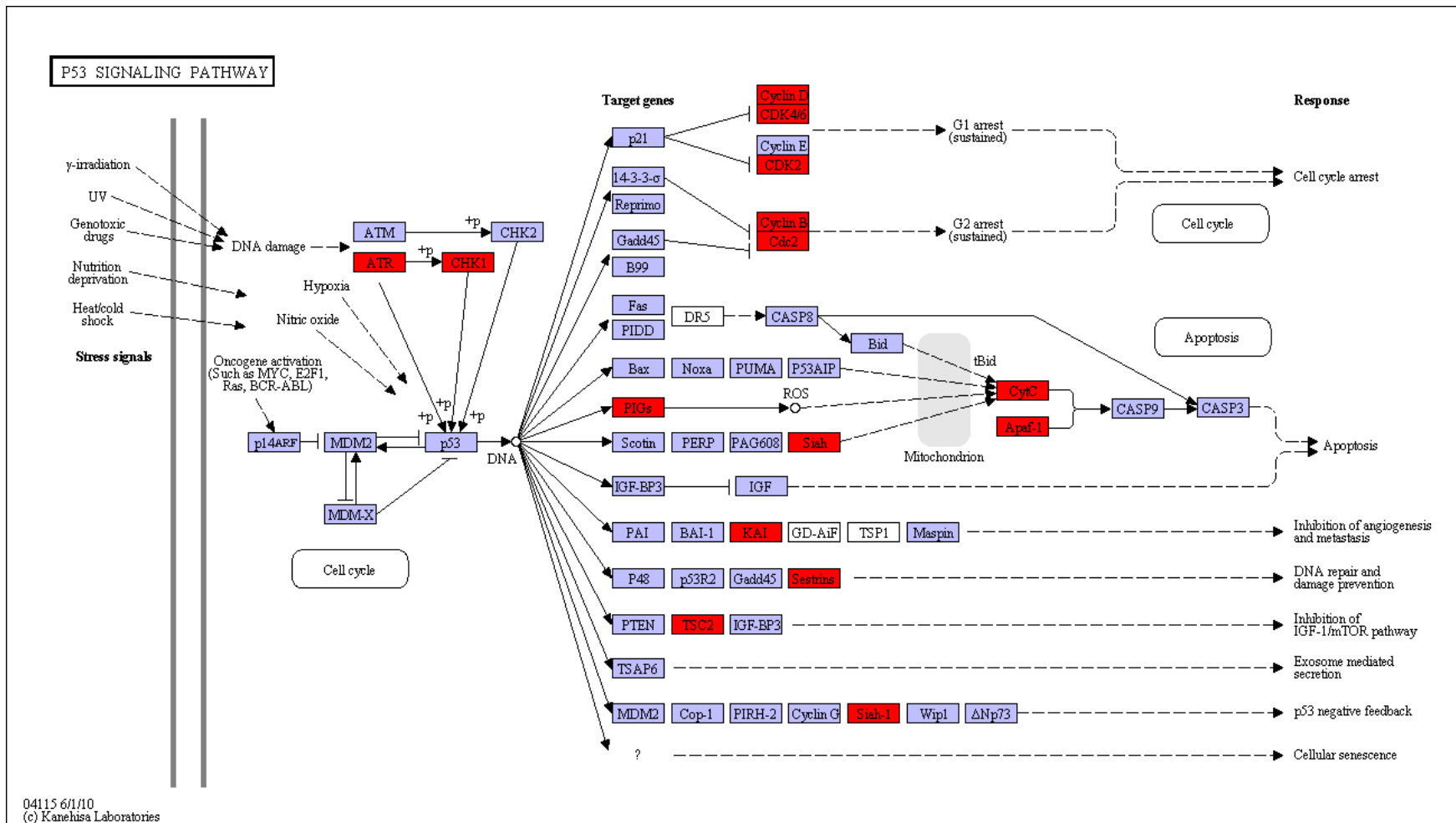

Figure 109: ko04115 p53 signaling pathway



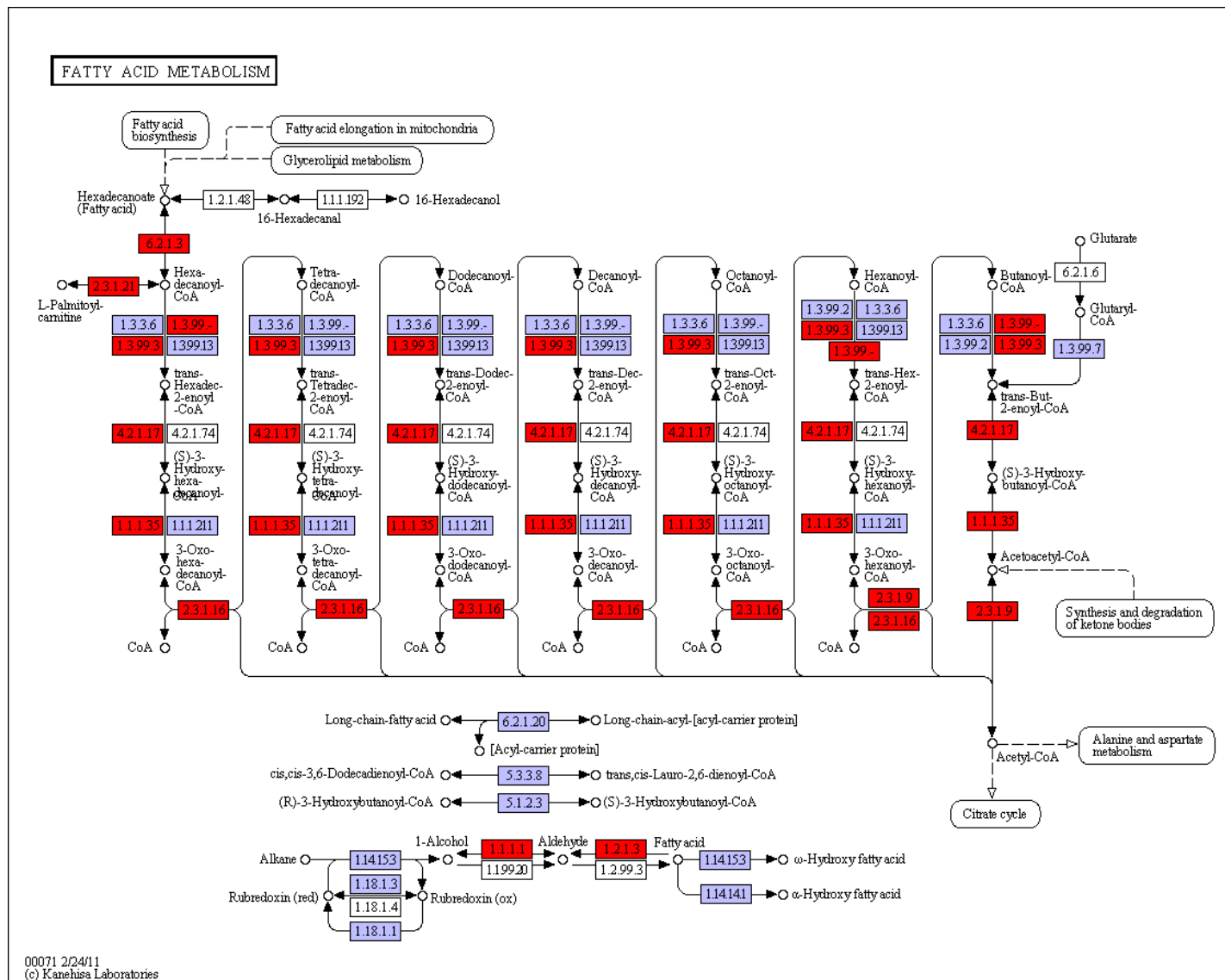

Figure 111: ko00071 Fatty acid metabolism





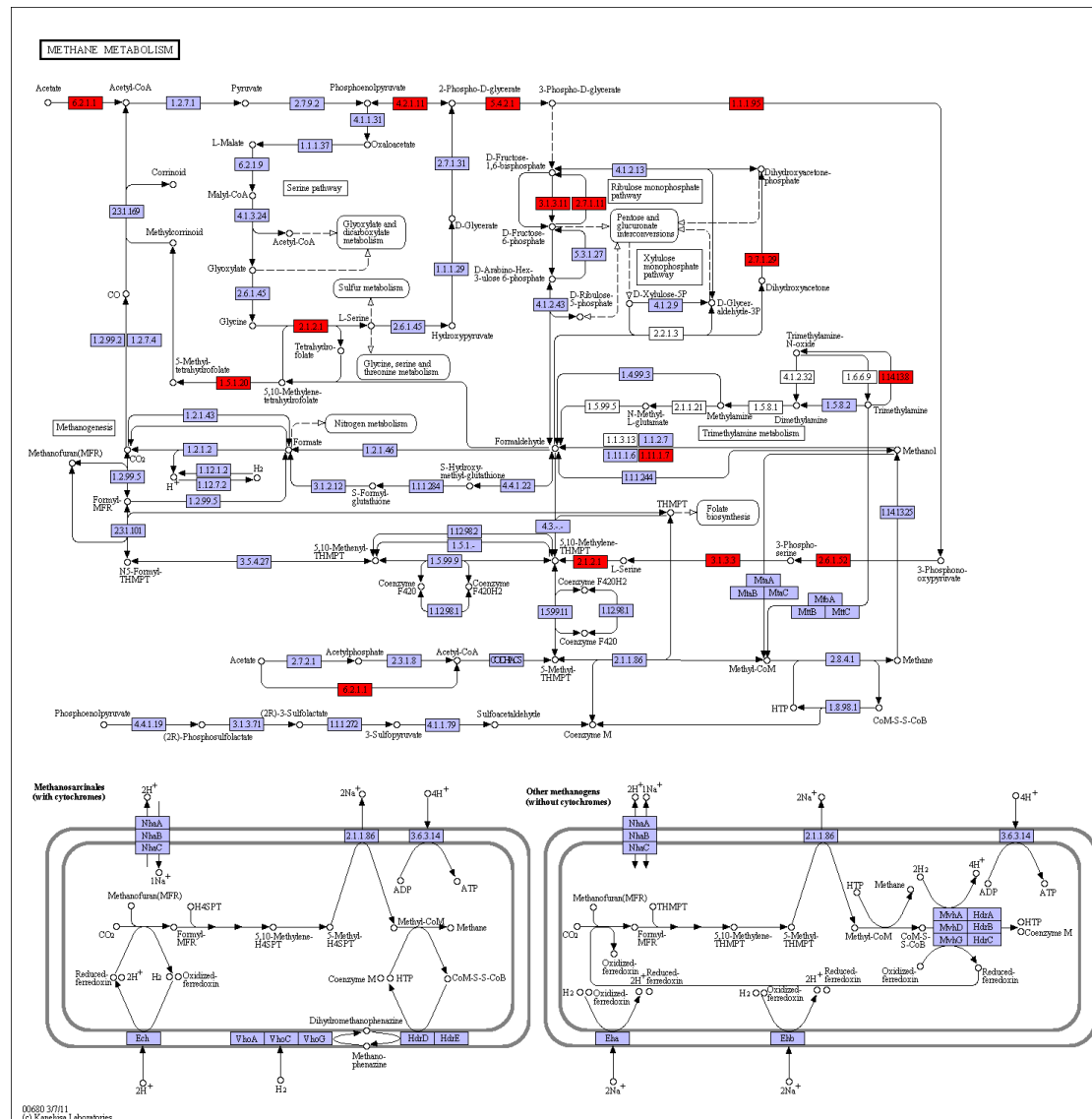

Figure 113: ko00680 Methane metabolism

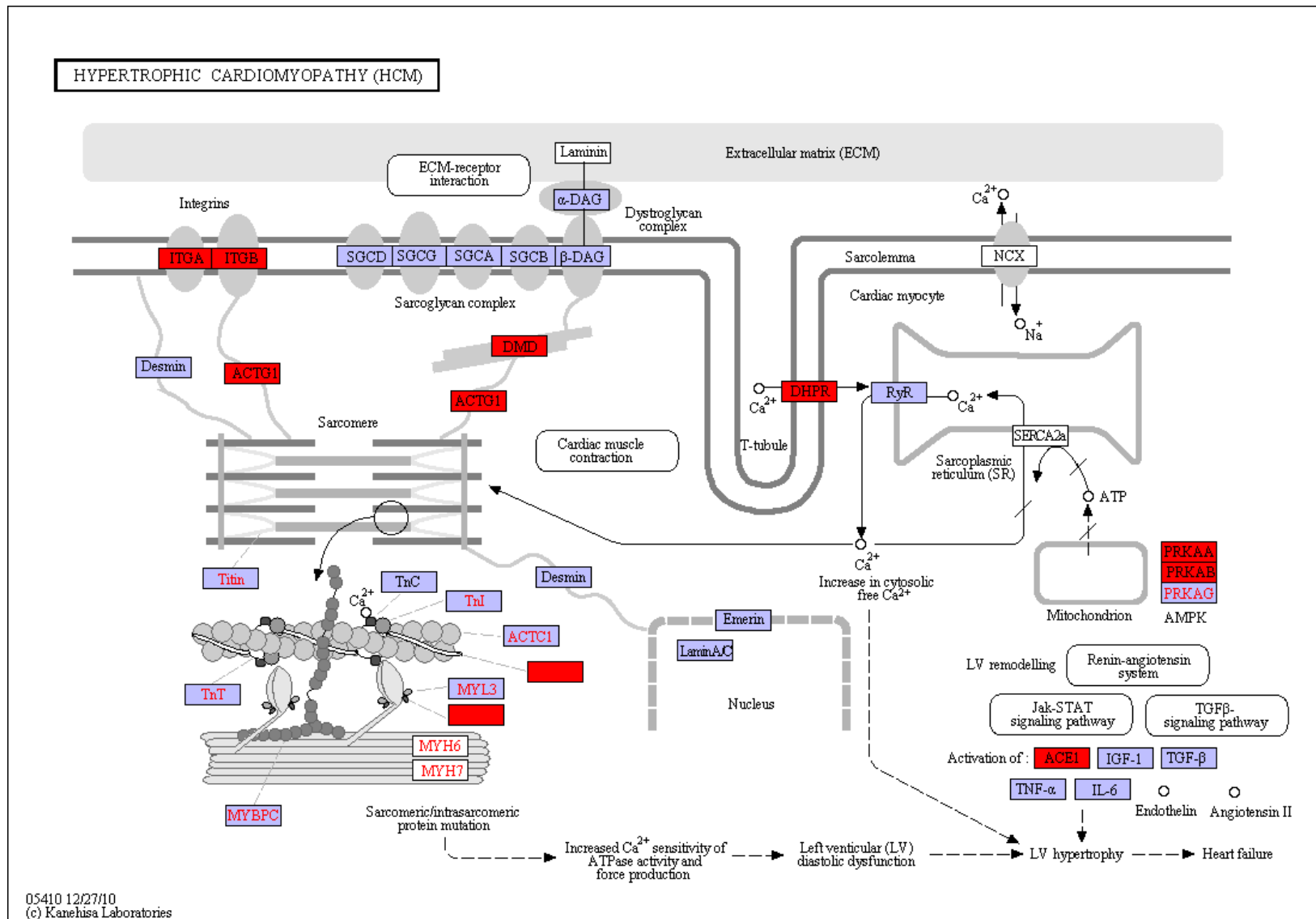

Figure 114: ko05410 Hypertrophic cardiomyopathy (HCM)

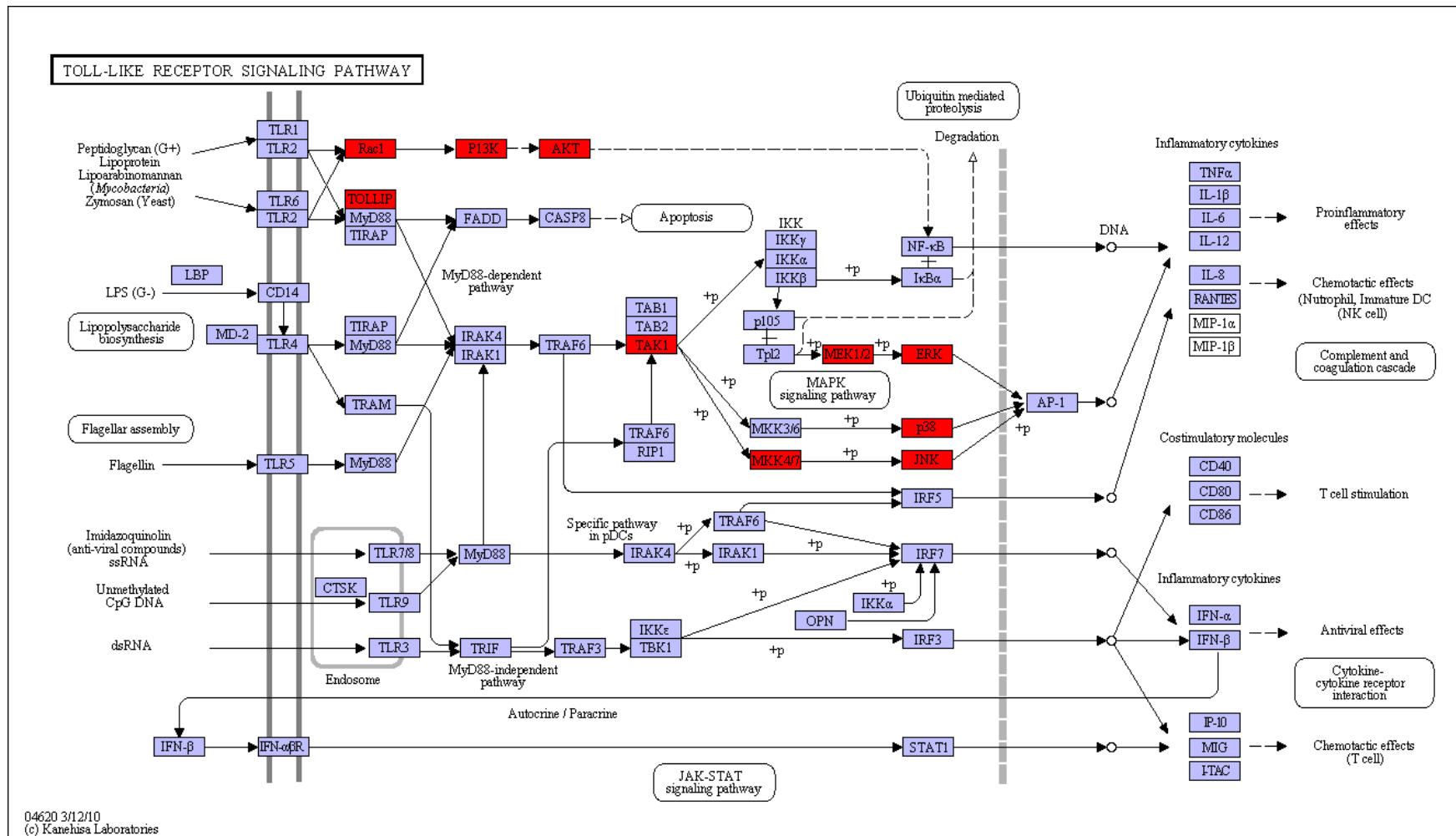

Figure 115: ko04620 Toll-like receptor signaling pathway

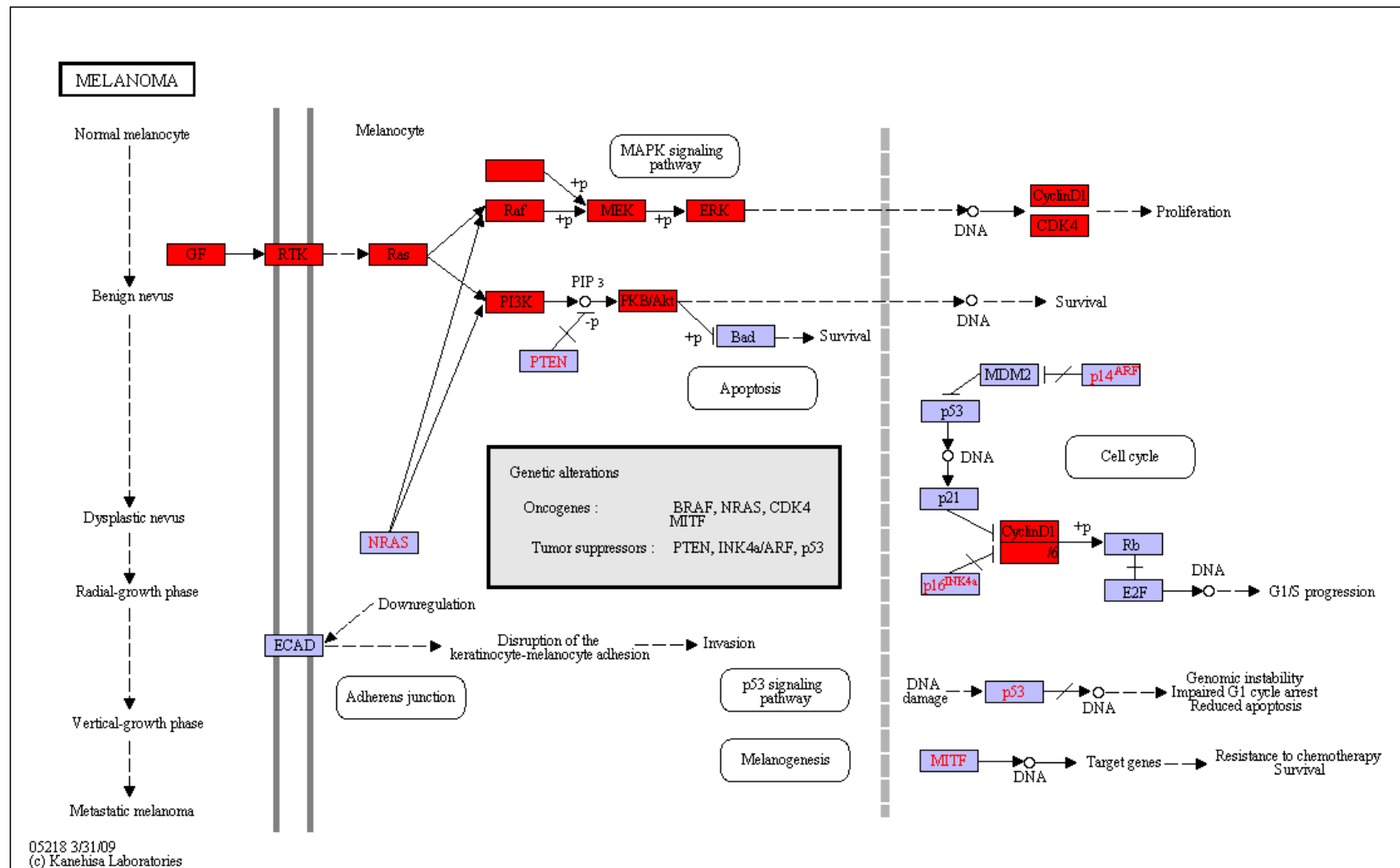

Figure 116: ko05218 Melanoma

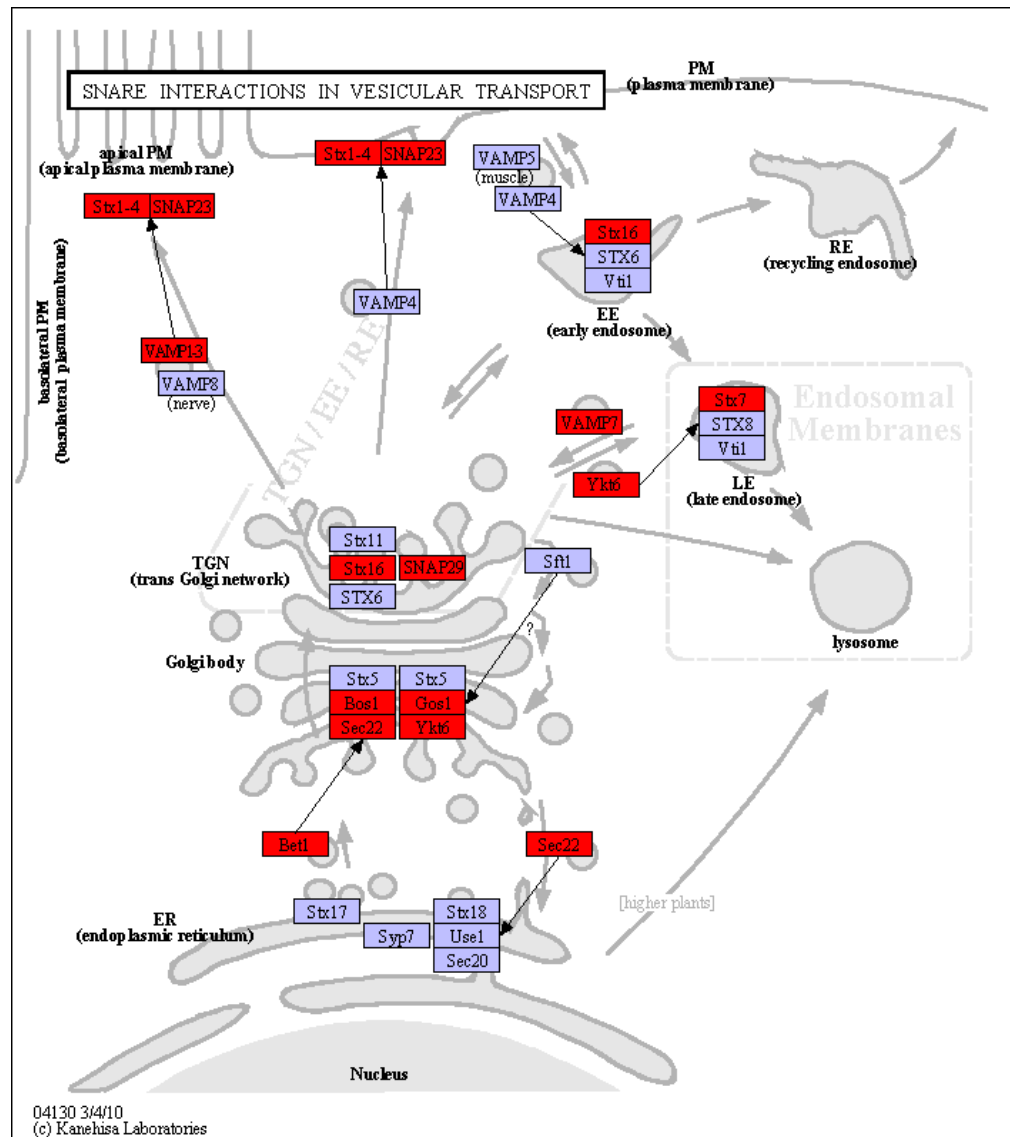

Figure 117: ko04130 SNARE interactions in vesicular transport

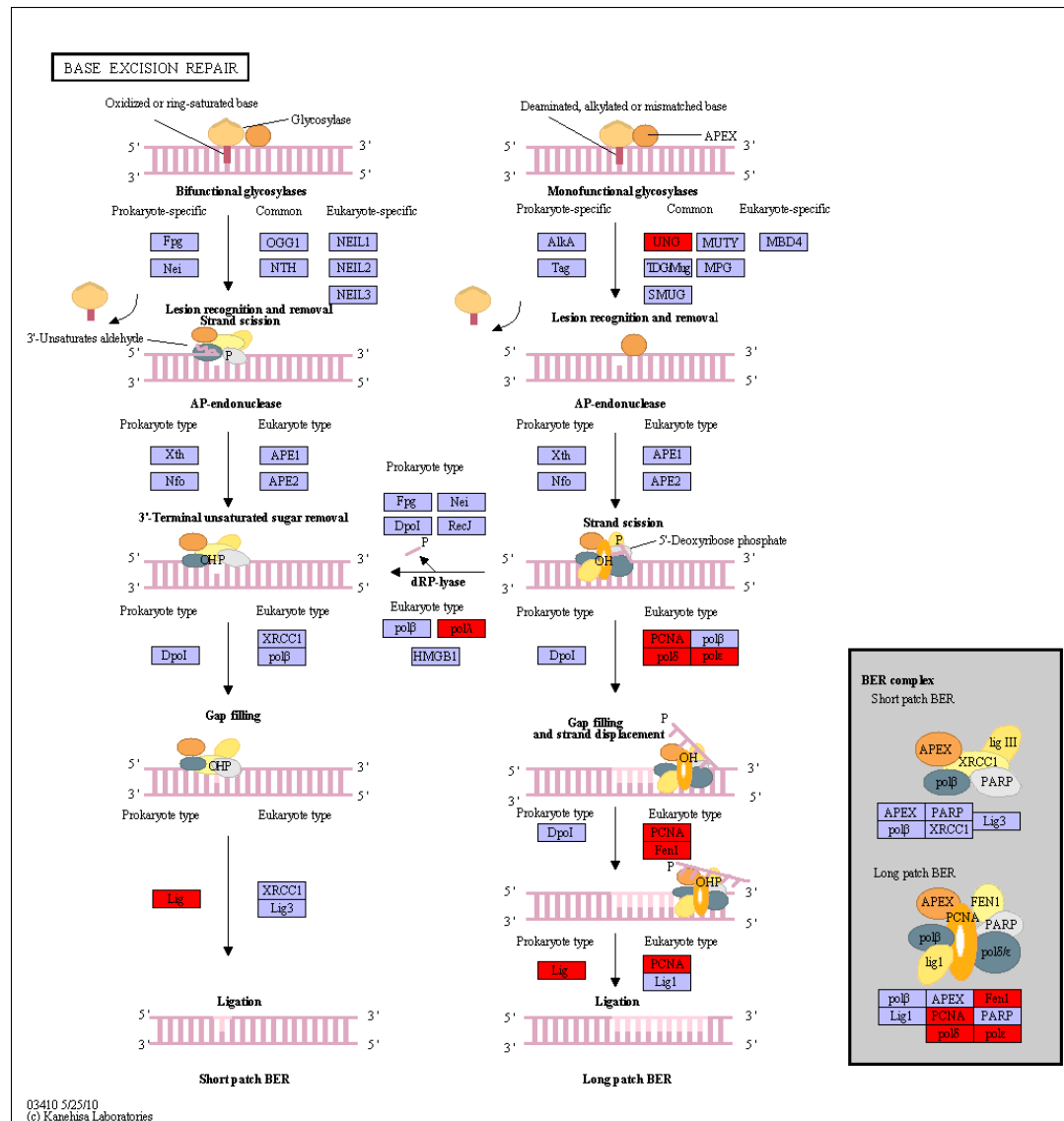

Figure 118: ko03410 Base excision repair

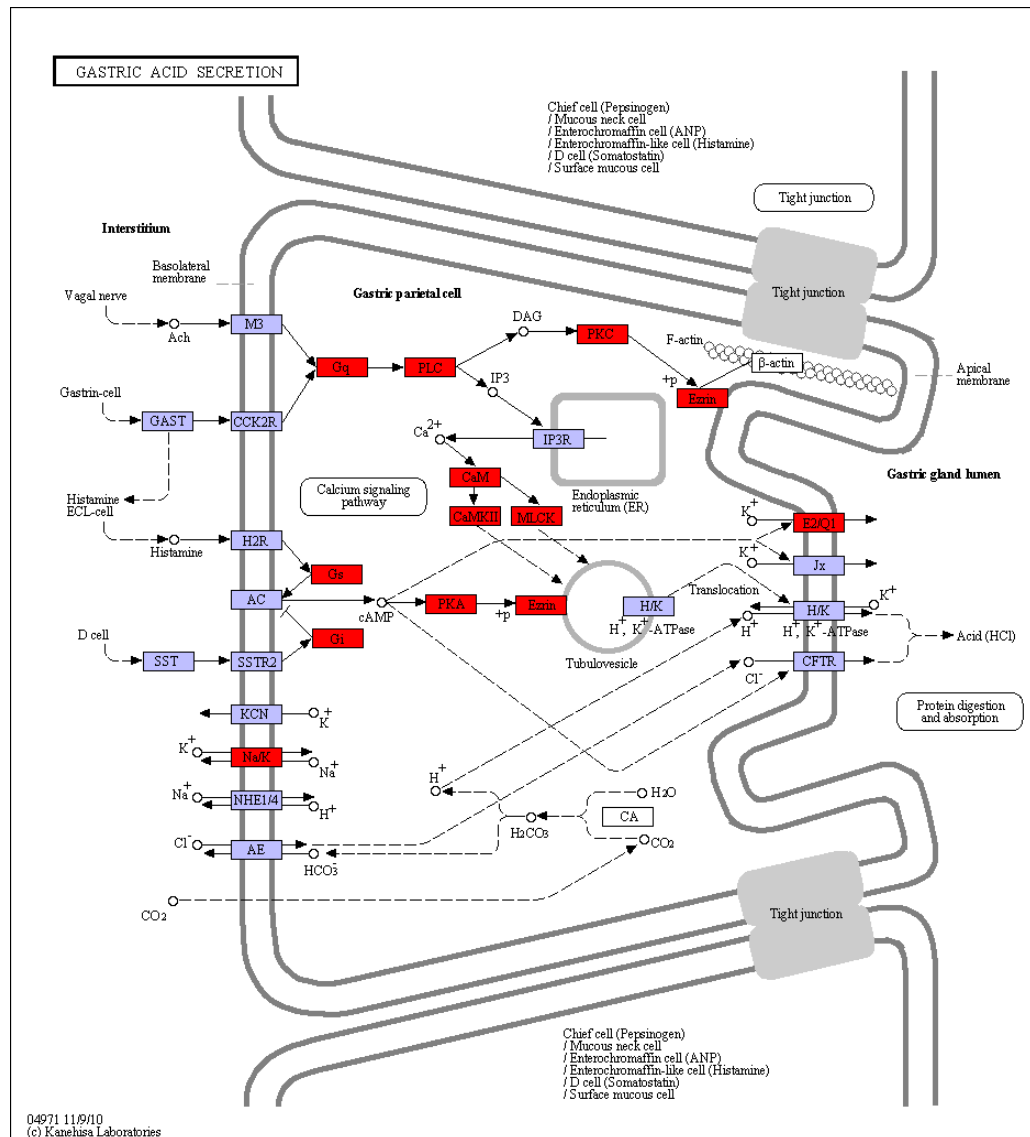
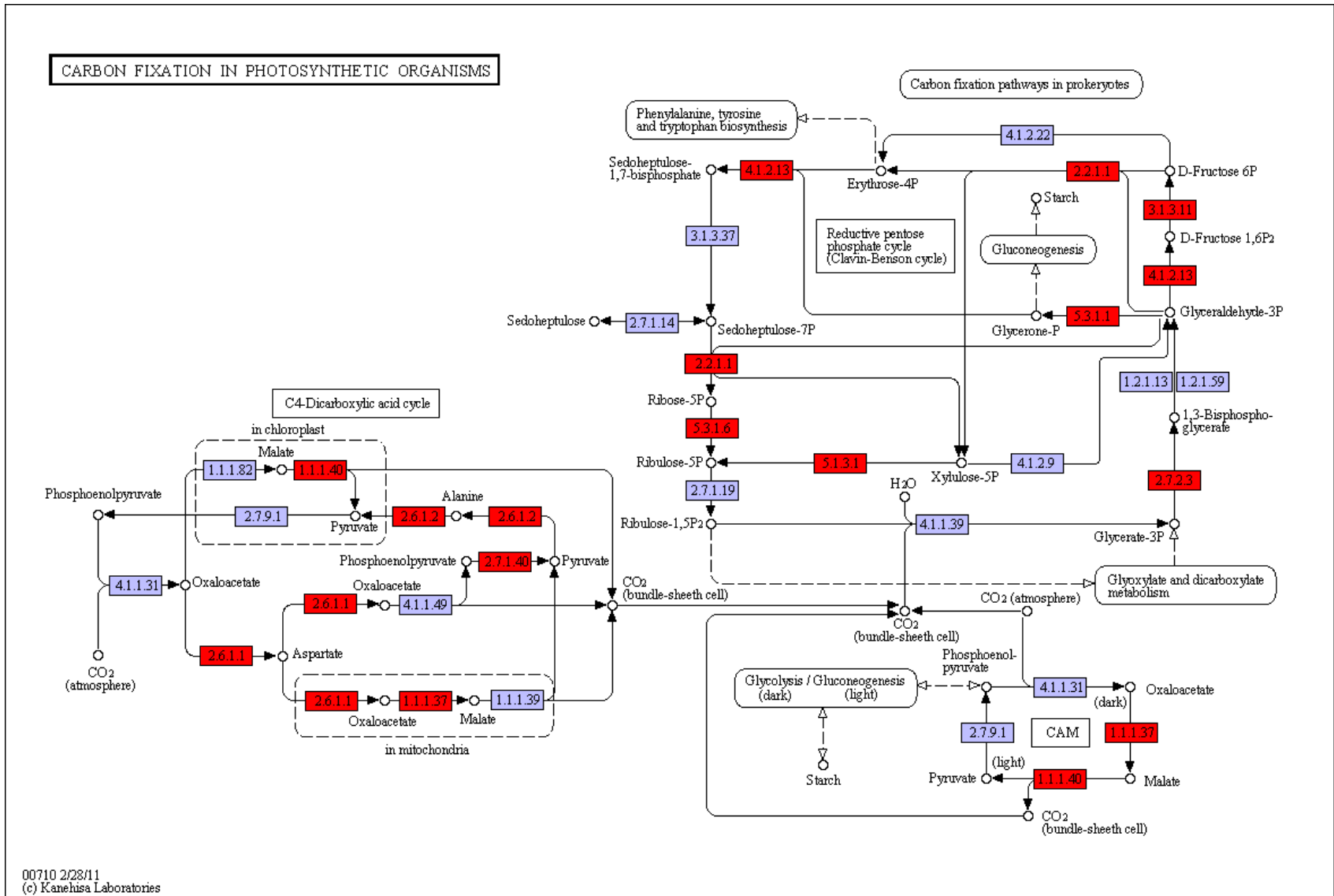

Figure 119: ko04971 Gastric acid secretion





00710 2/28/11  
 (c) Kanehisa Laboratories

Figure 120: ko00710 Carbon fixation in photosynthetic organisms

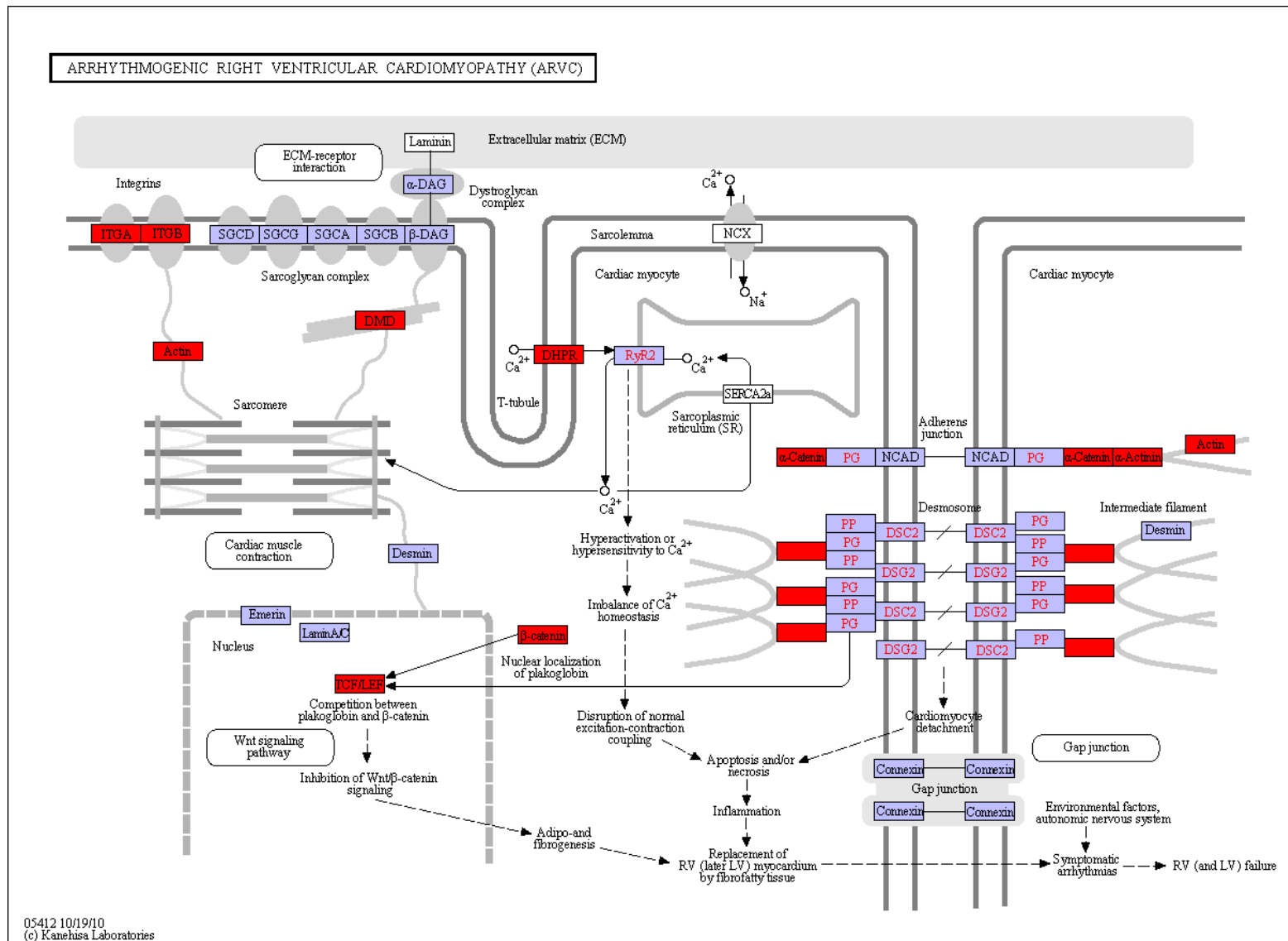

Figure 121: ko05412 Arrhythmogenic right ventricular cardiomyopathy (ARVC)



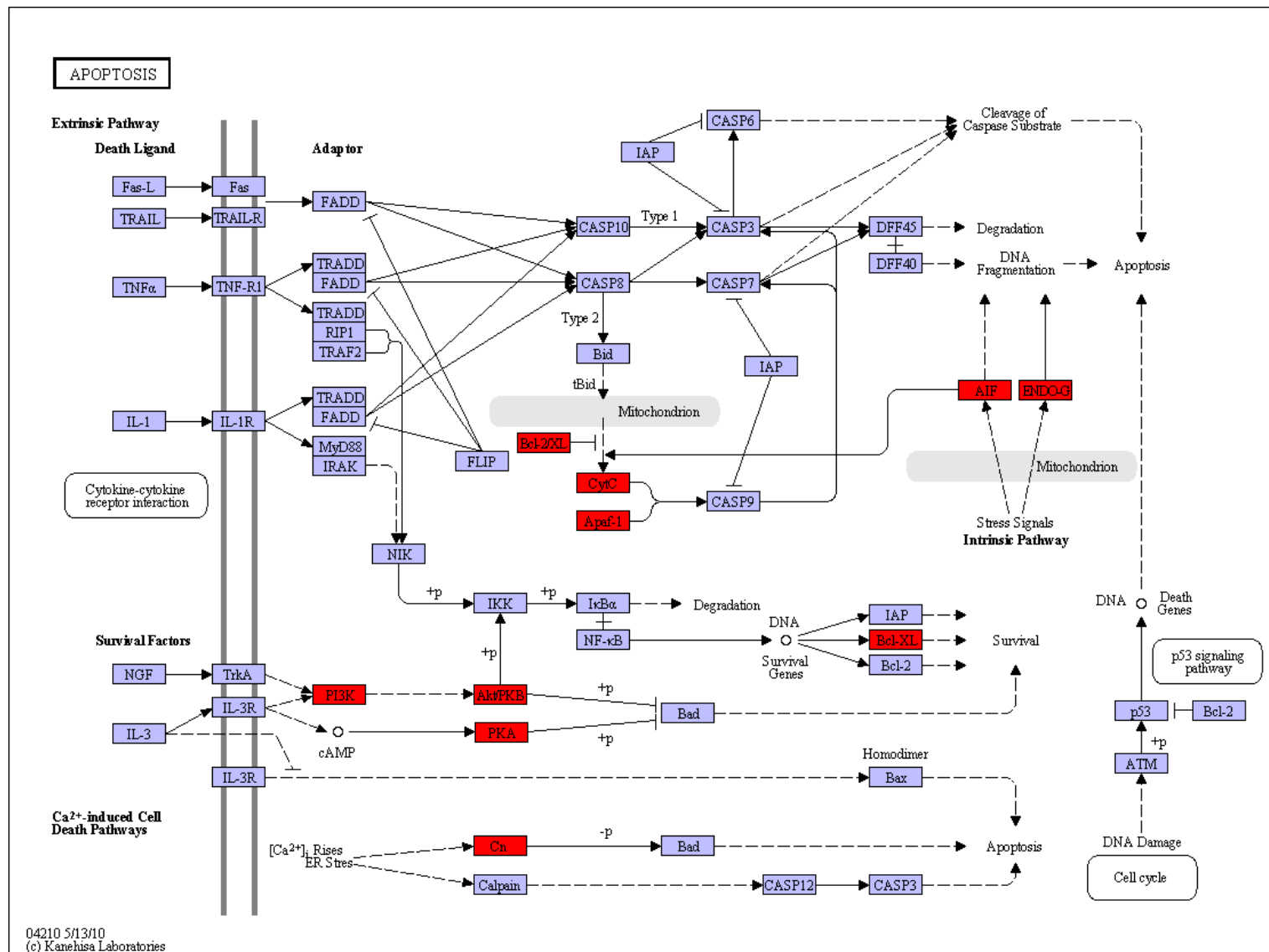

Figure 123: ko04210 Apoptosis

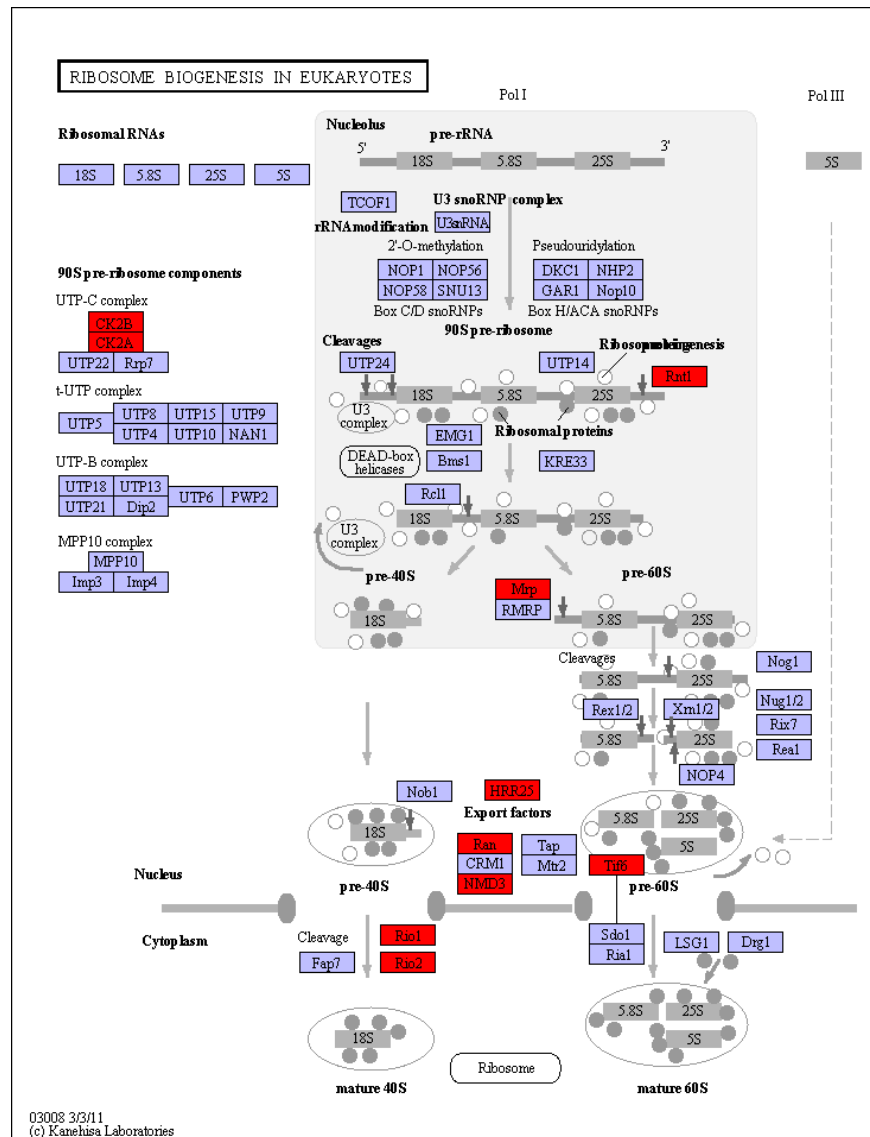

Figure 124: ko03008 Ribosome biogenesis in eukaryotes





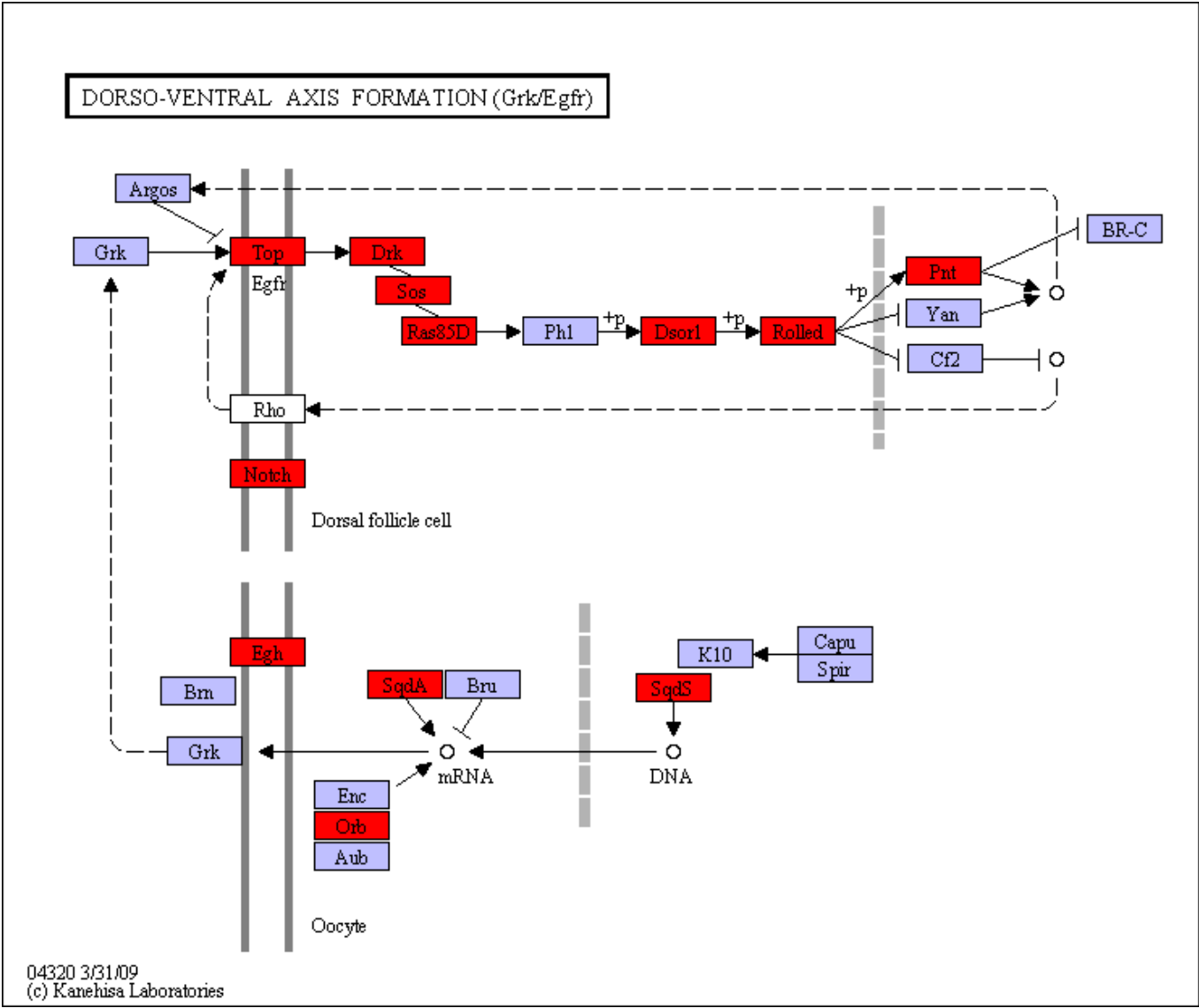

Figure 127: ko04320 Dorso-ventral axis formation



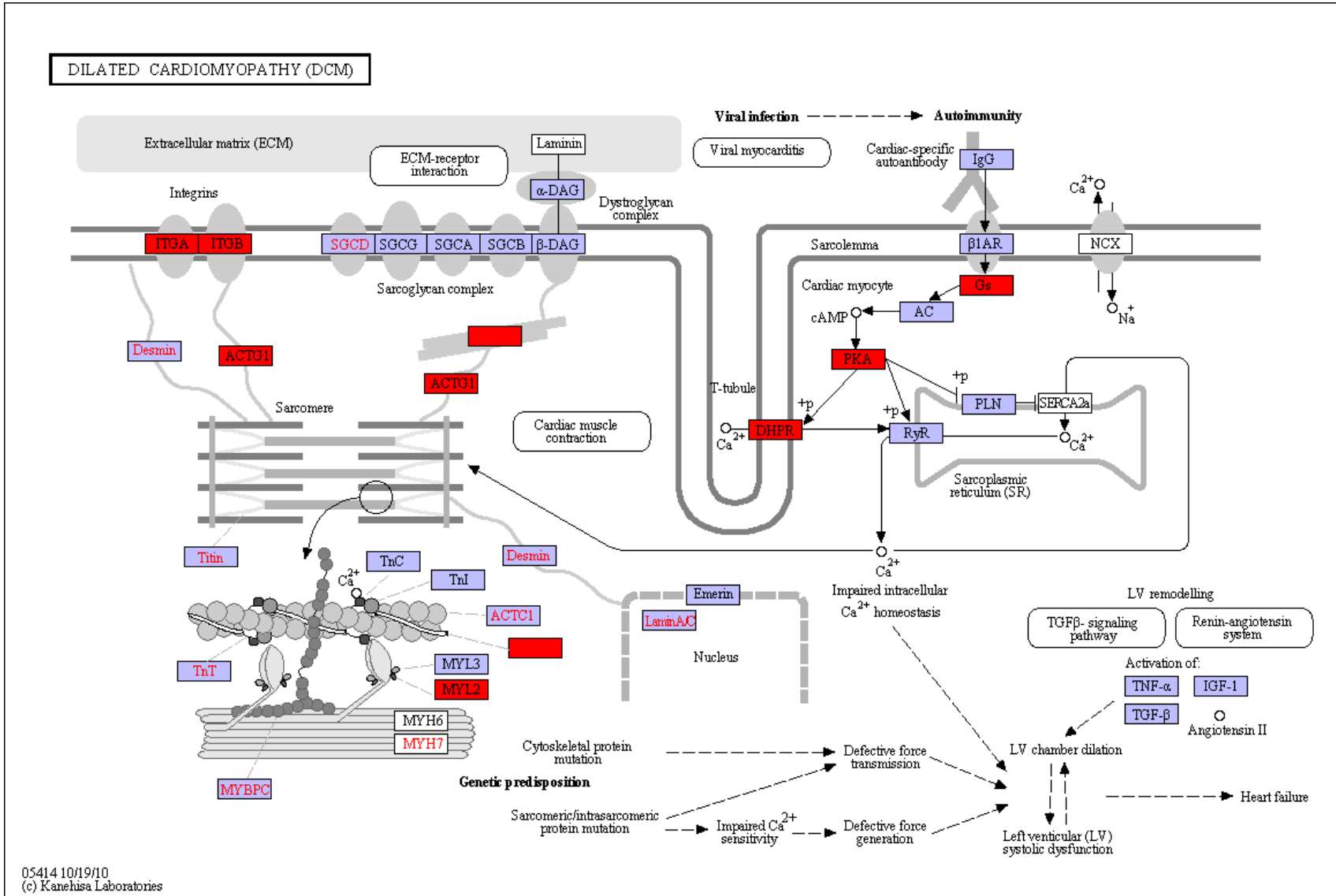

Figure 128: ko05414 Dilated cardiomyopathy

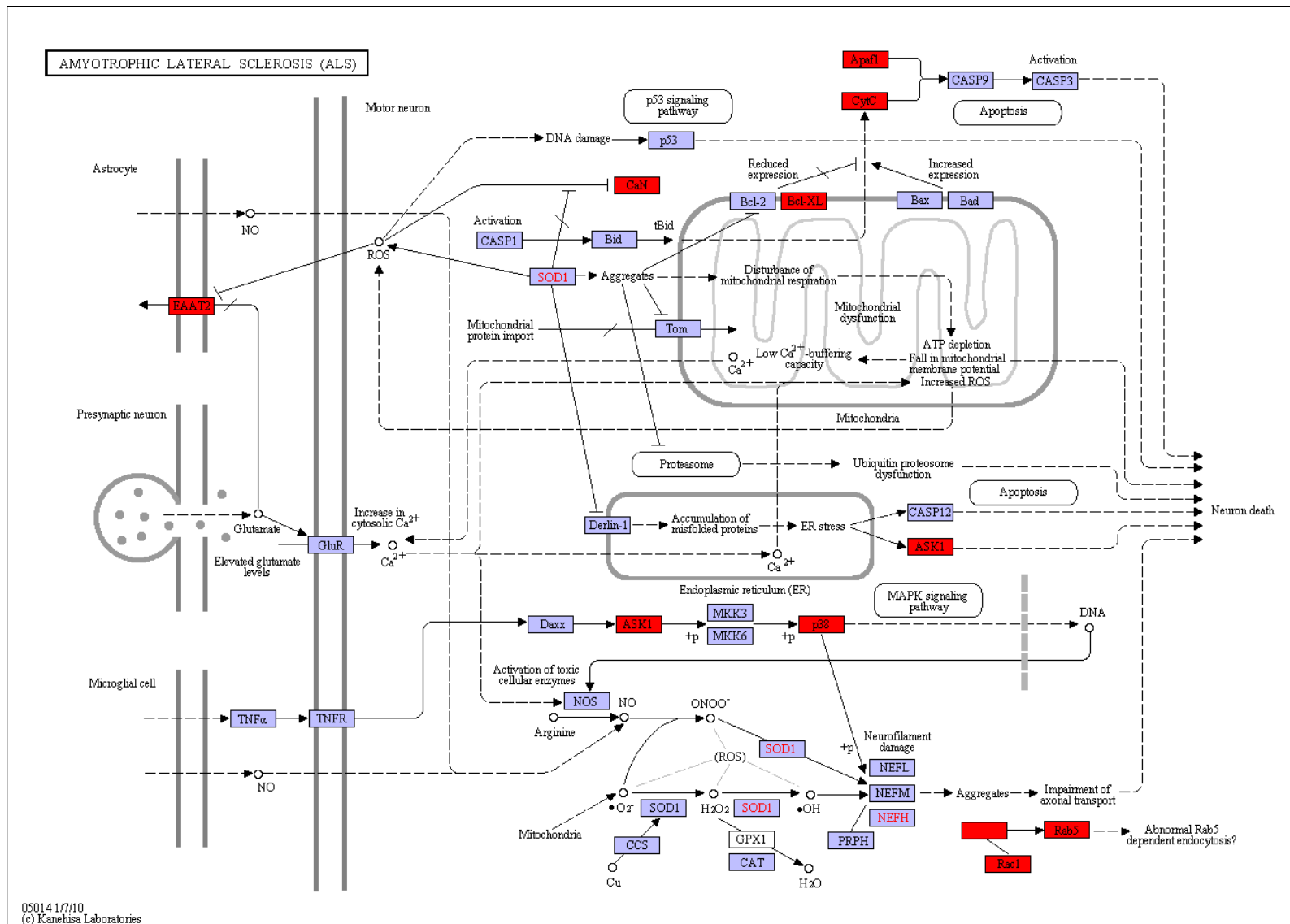

Figure 129: ko05014 Amyotrophic lateral sclerosis (ALS)

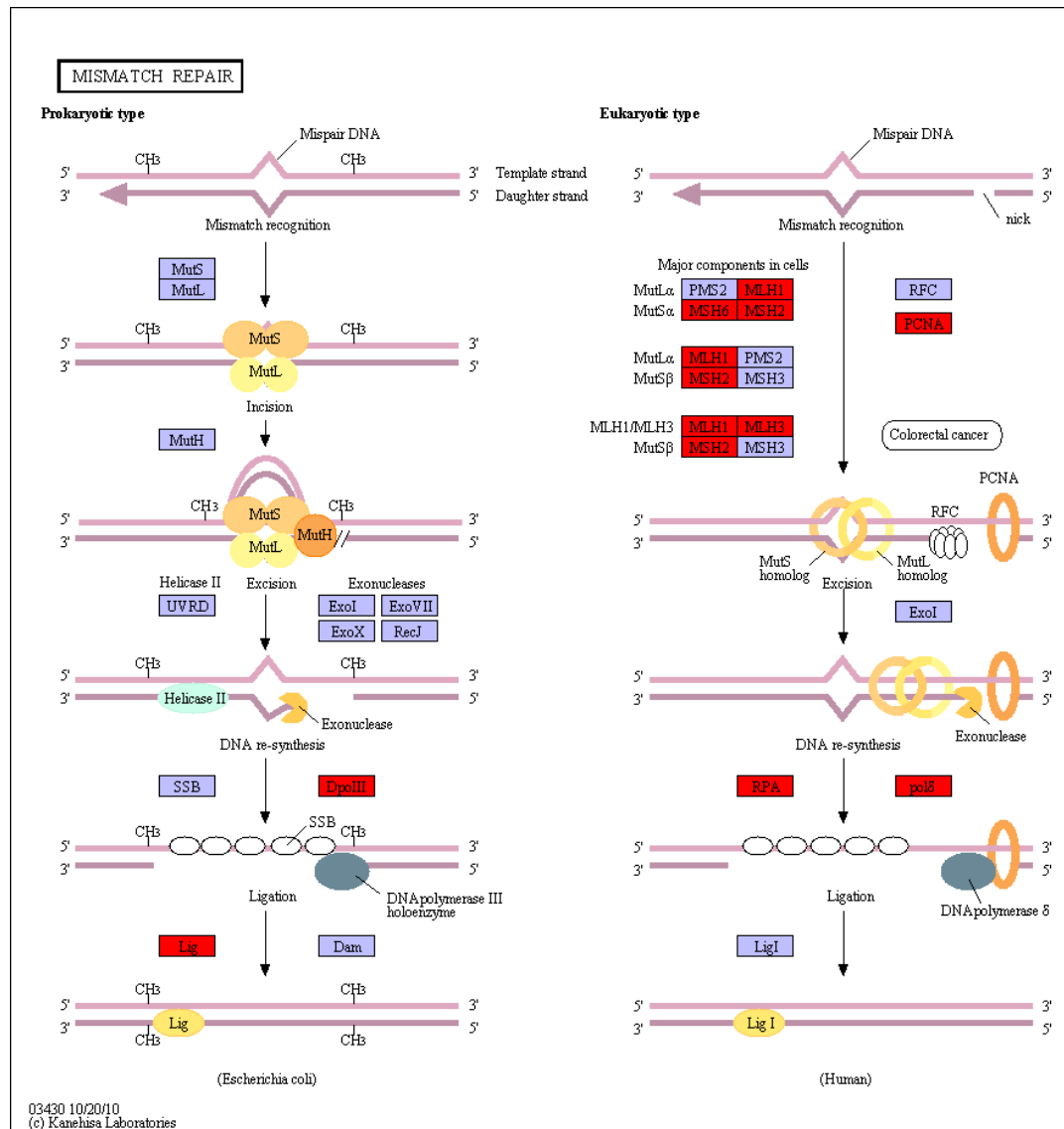

Figure 130: ko03430 Mismatch repair



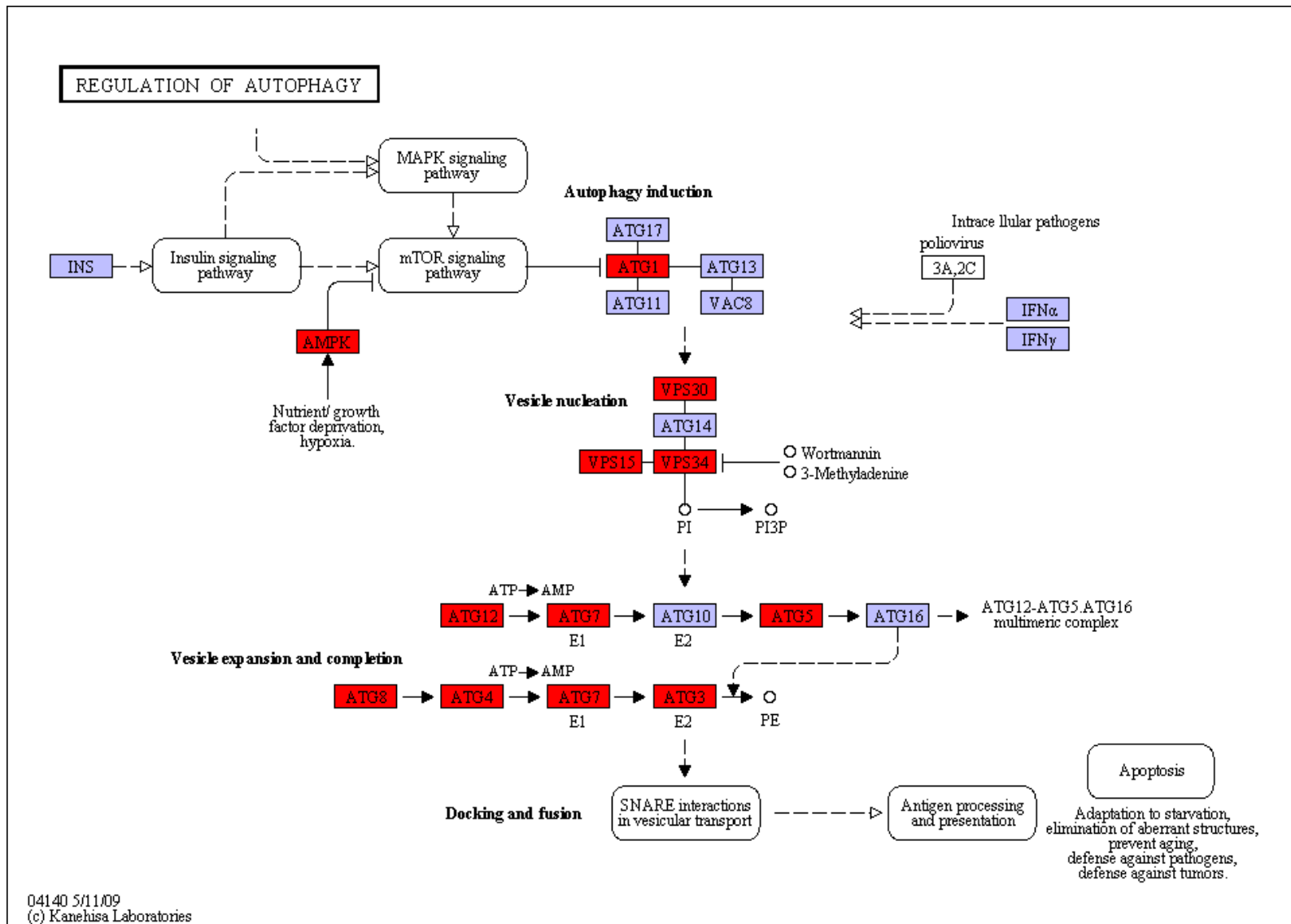

Figure 132: ko04140 Regulation of autophagy



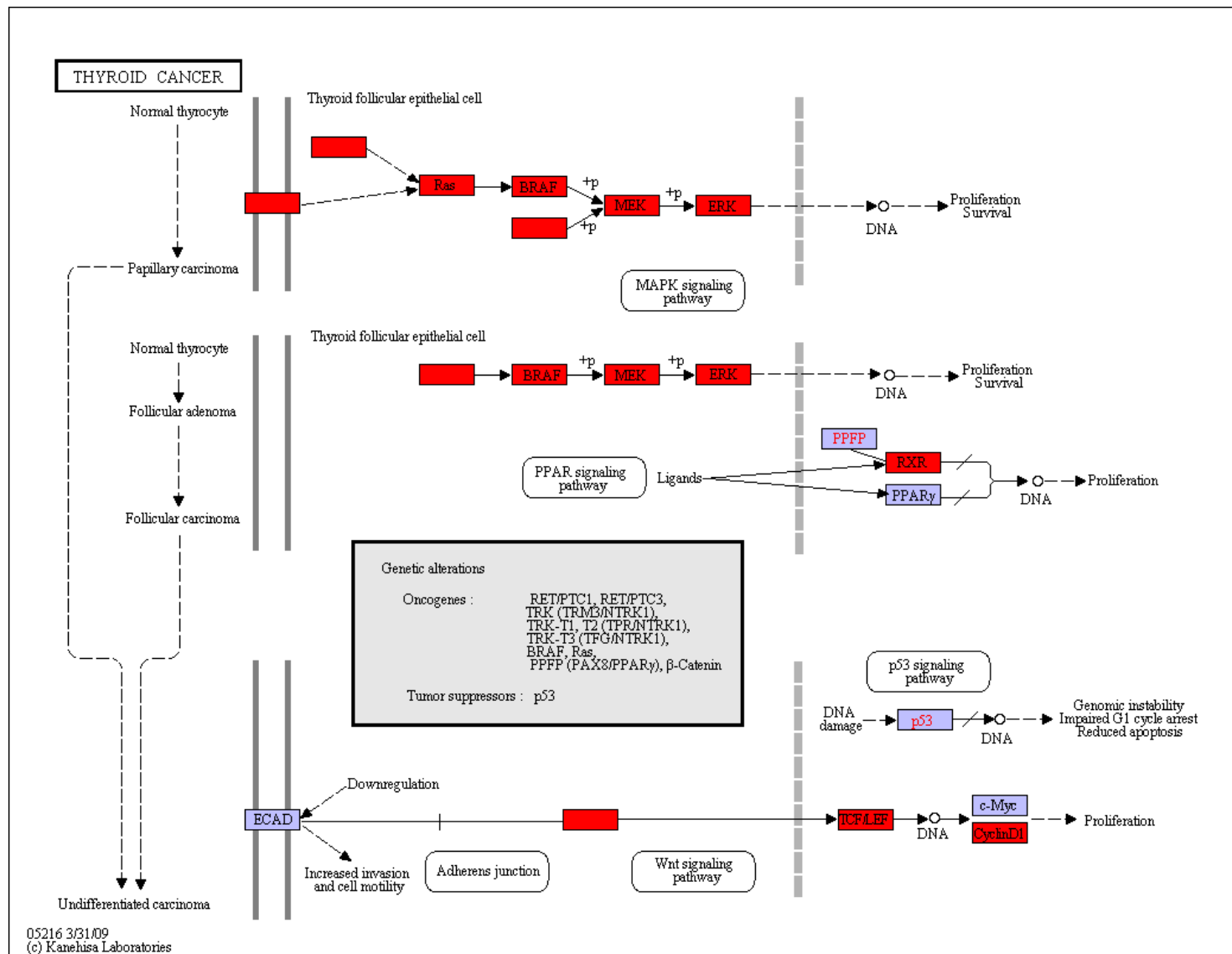

Figure 134: ko05216 Thyroid cancer

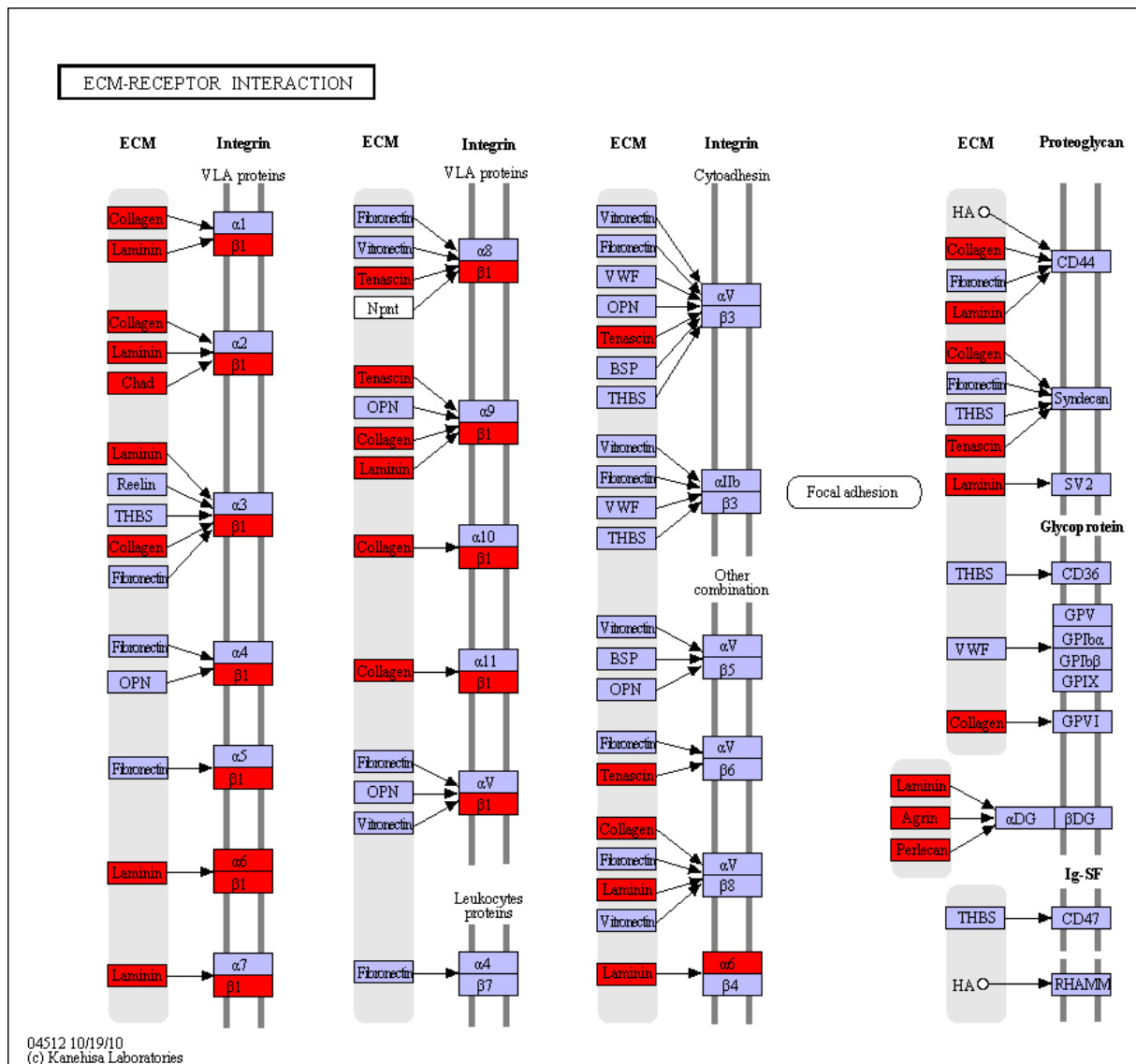

Figure 135: ko04512 ECM-receptor interaction



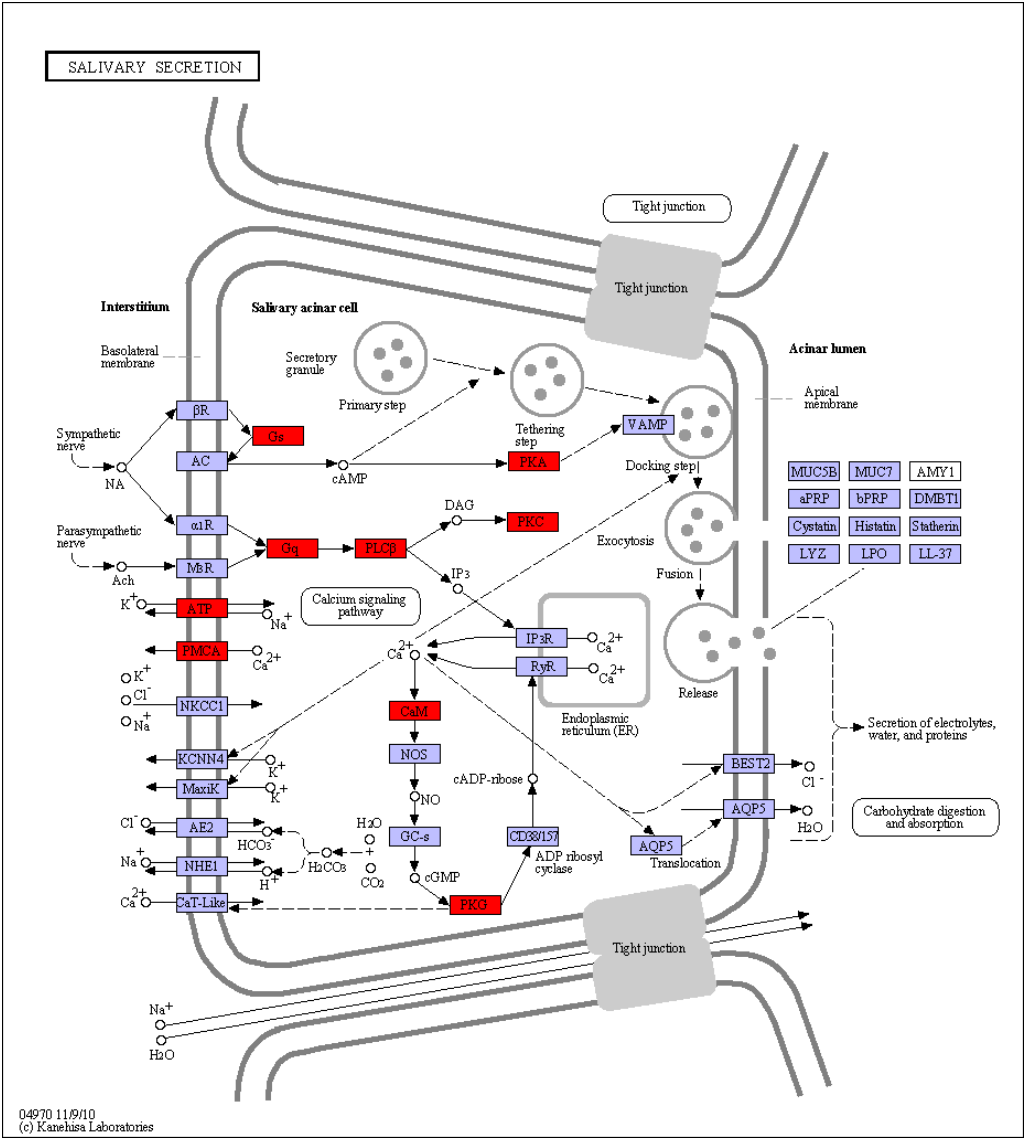

Figure 136: ko04970 Salivary secretion



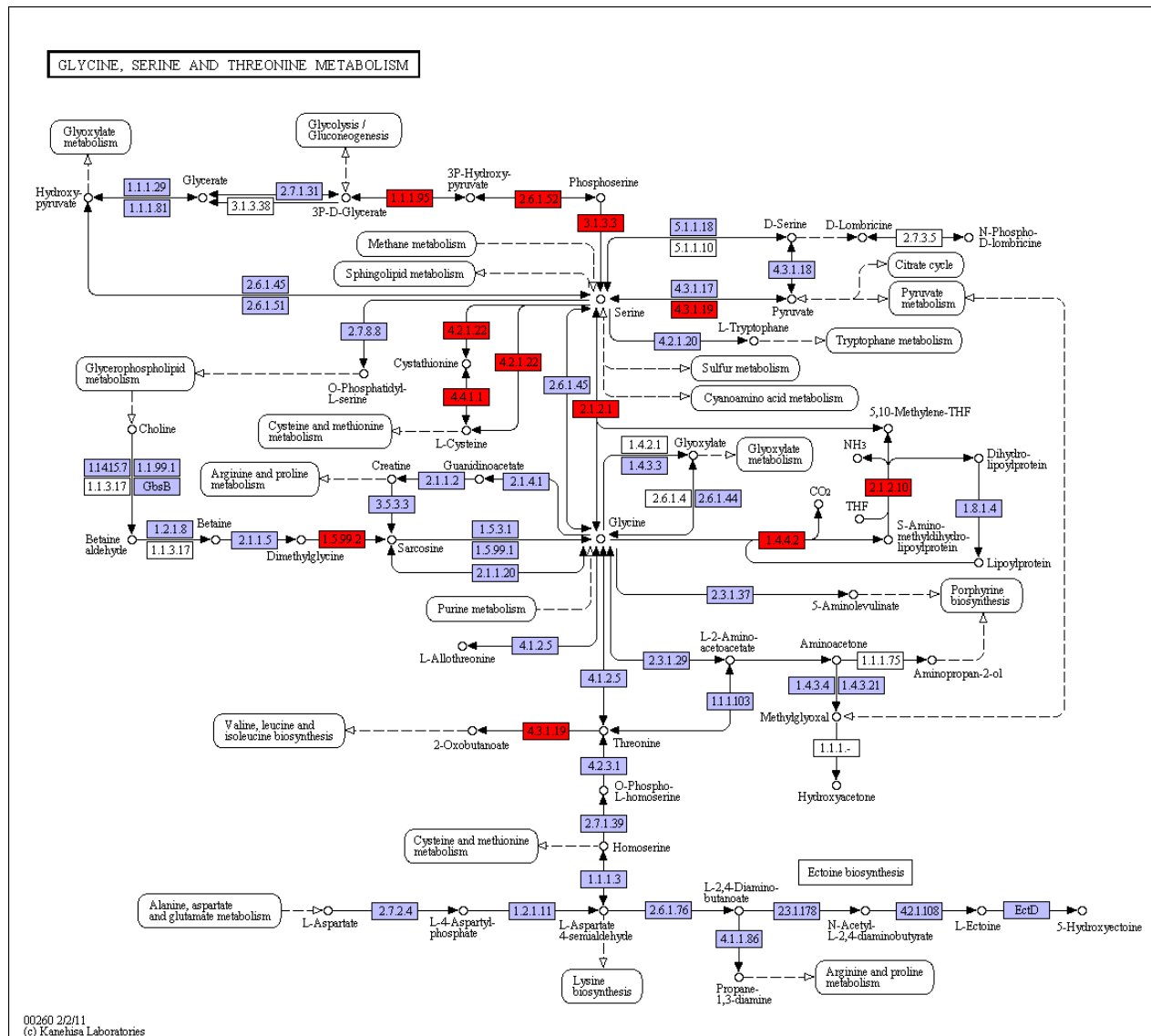

Figure 138: ko00260 Glycine, serine and threonine metabolism

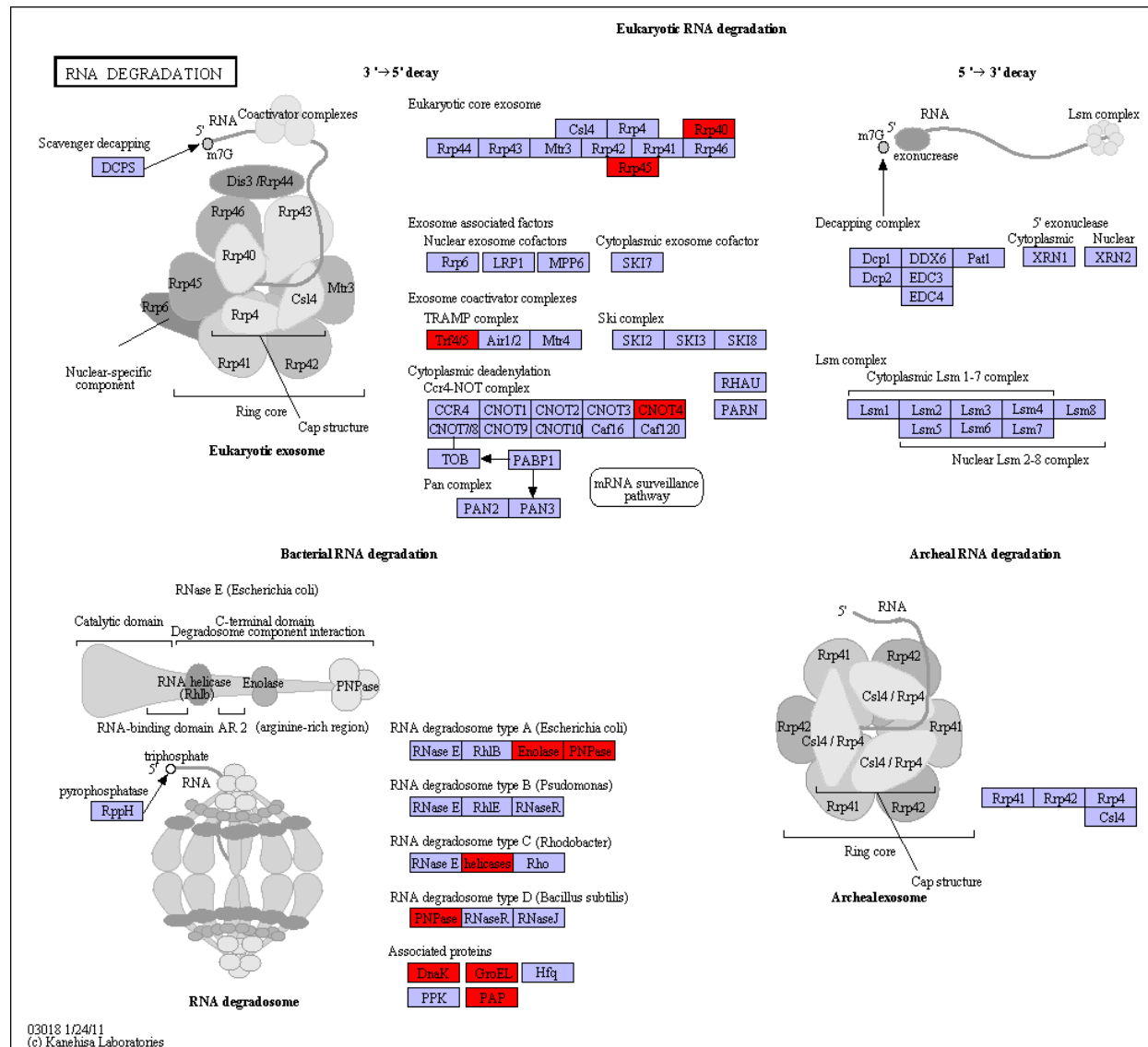

Figure 139: ko03018 RNA degradation

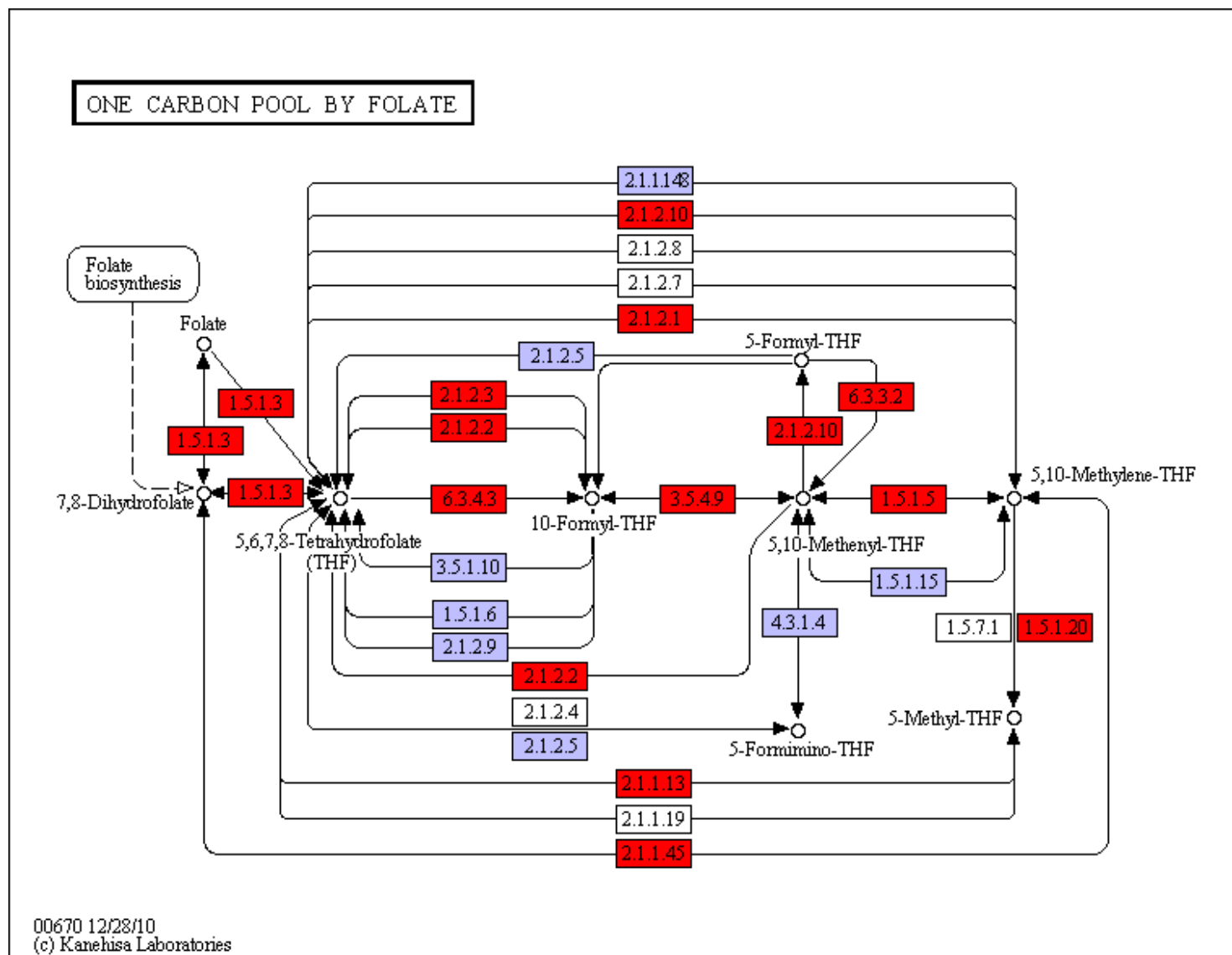

Figure 140: ko00670 One carbon pool by folate

GLYCOSAMINOGLYCAN BIOSYNTHESIS - HEPARAN SULFATE

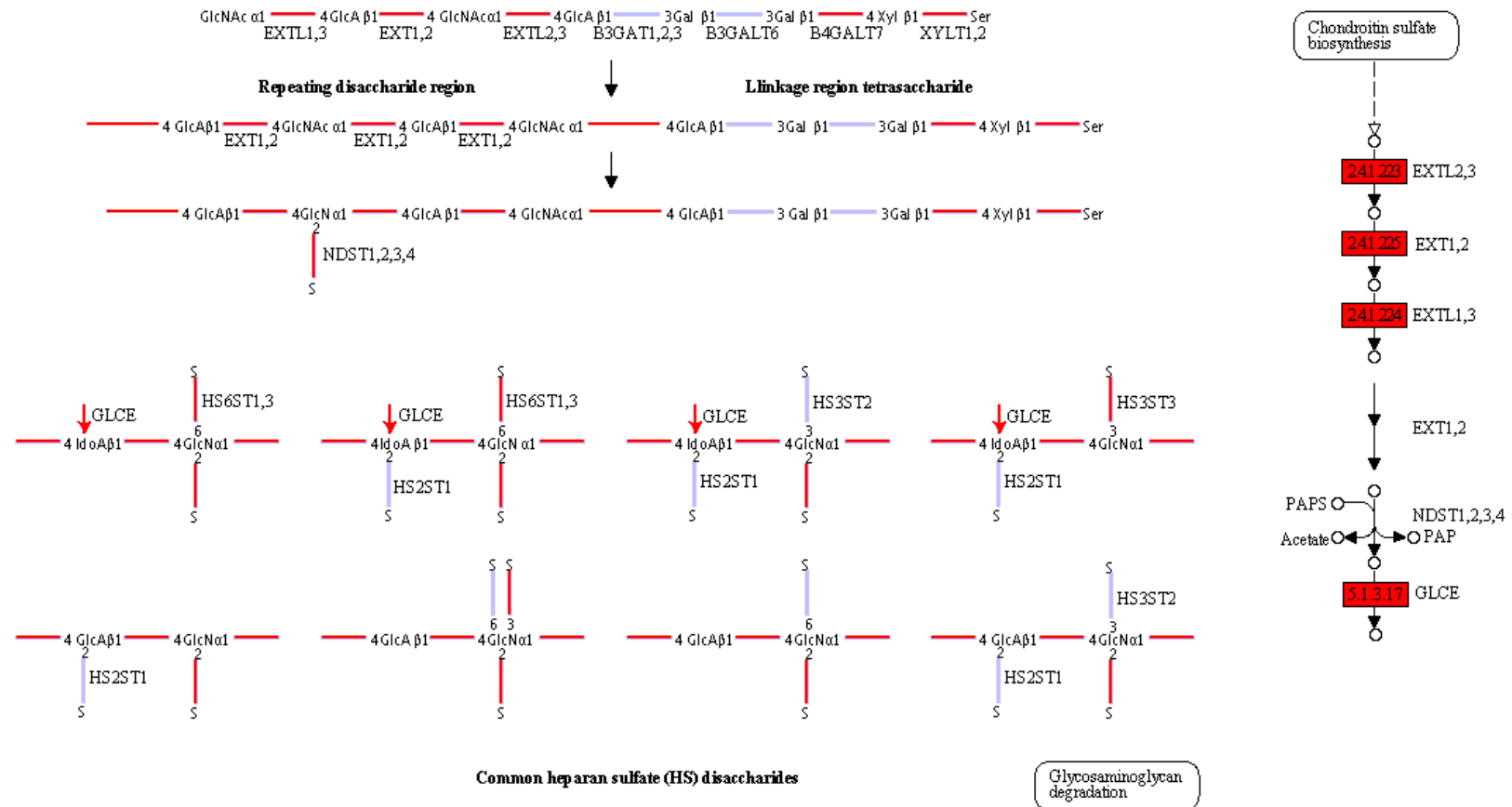

Figure 141: ko00534 Glycosaminoglycan biosynthesis - heparan sulfate



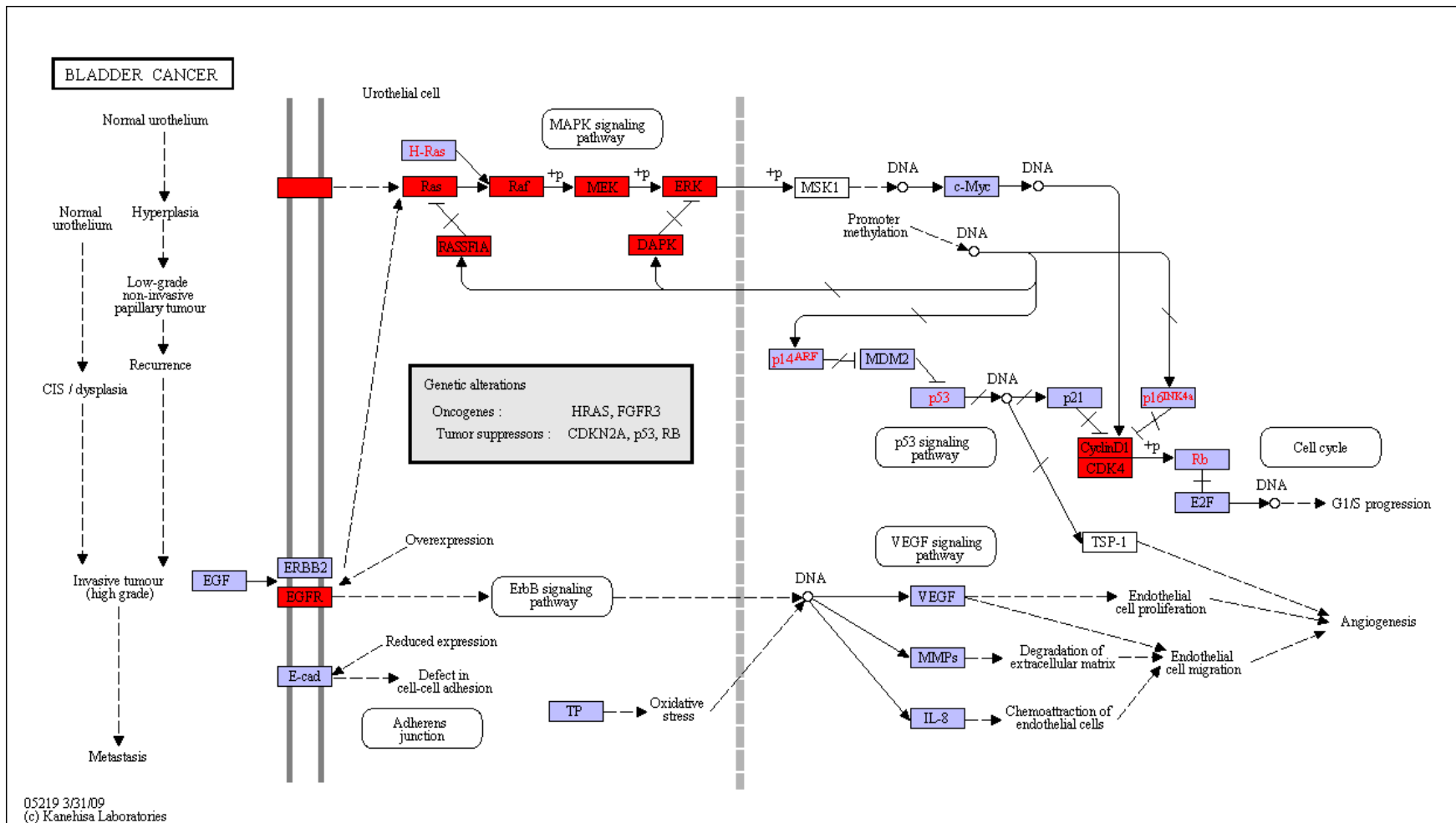

Figure 143: ko05219 Bladder cancer



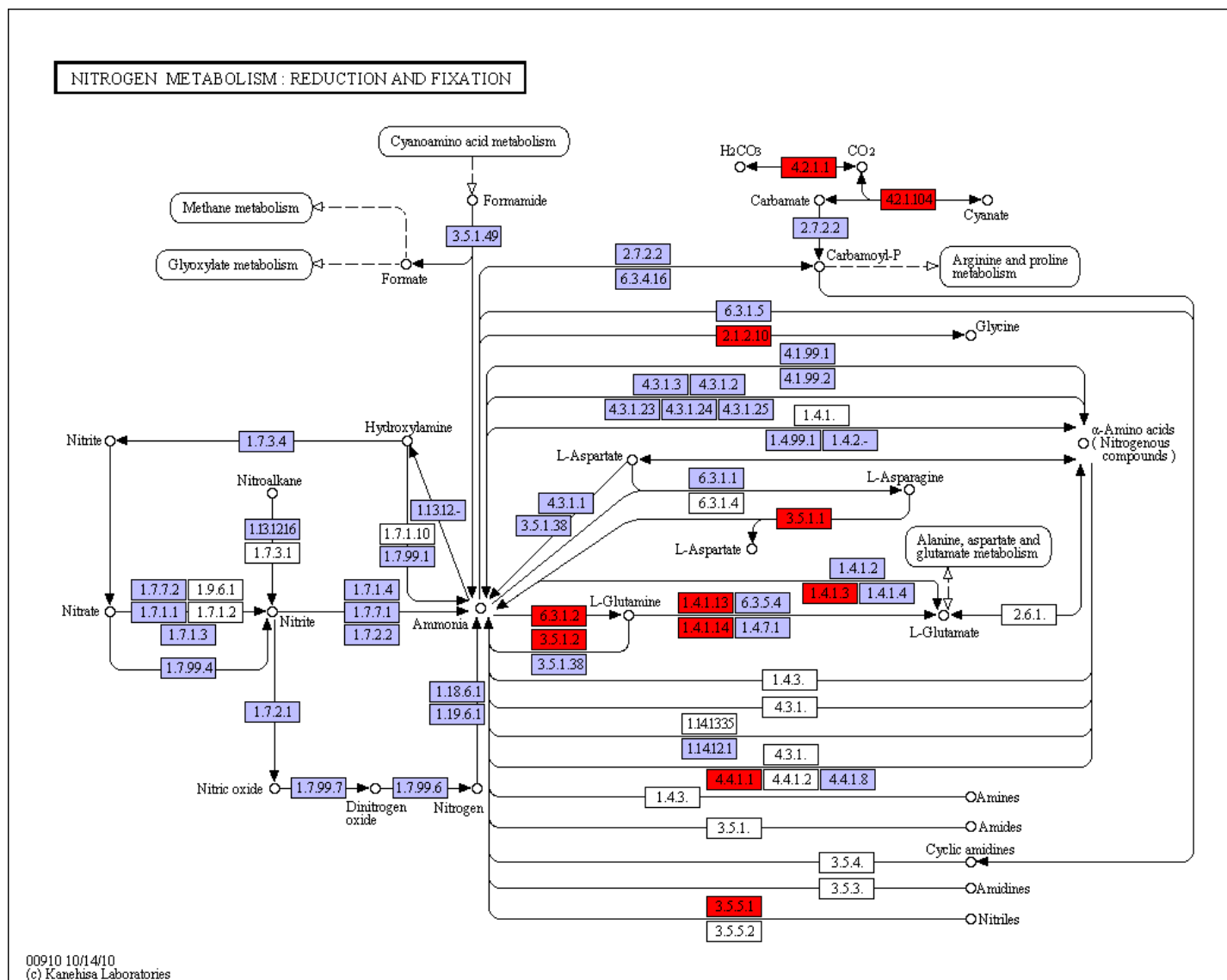

Figure 144: ko00910 Nitrogen metabolism

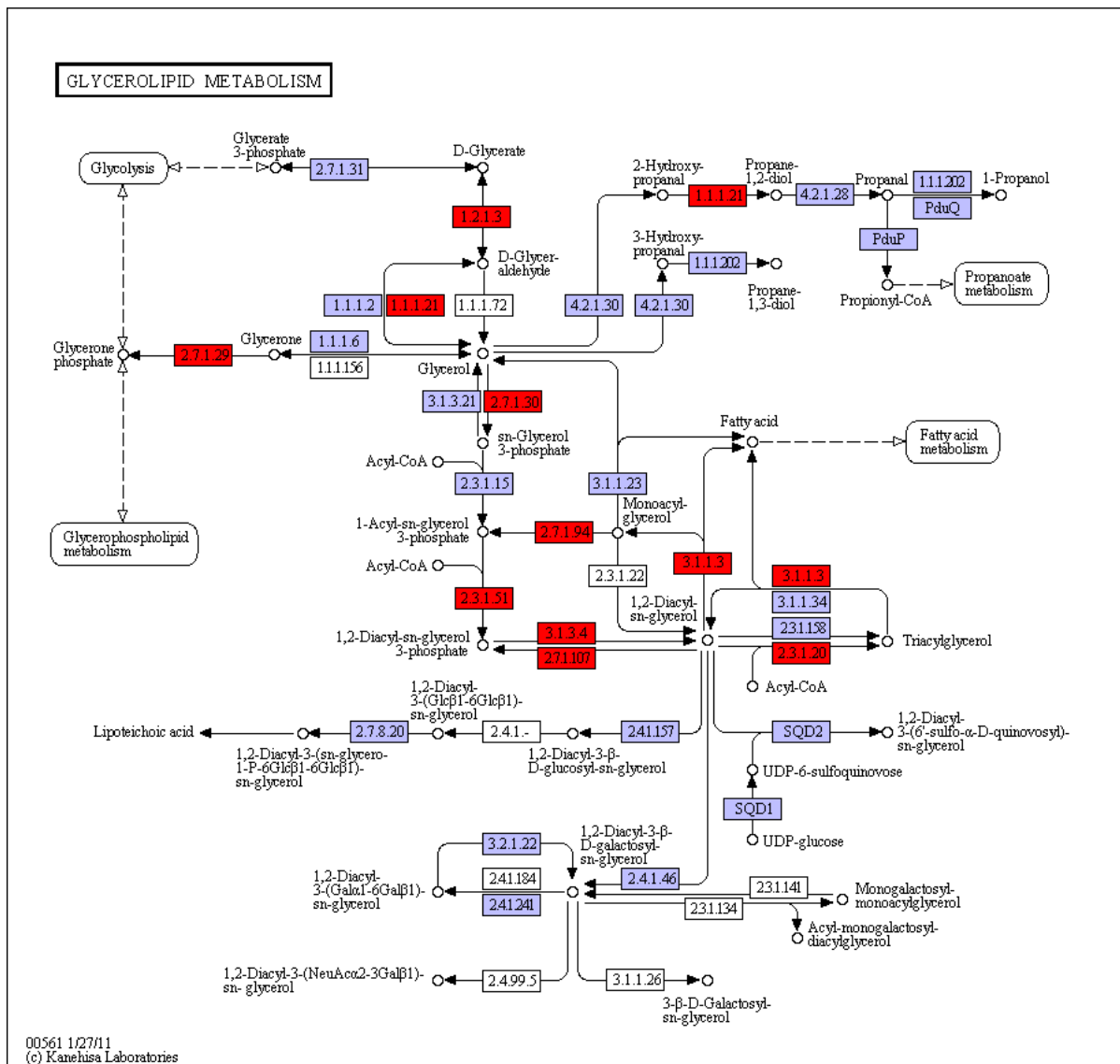

Figure 145: ko00561 Glycerolipid metabolism

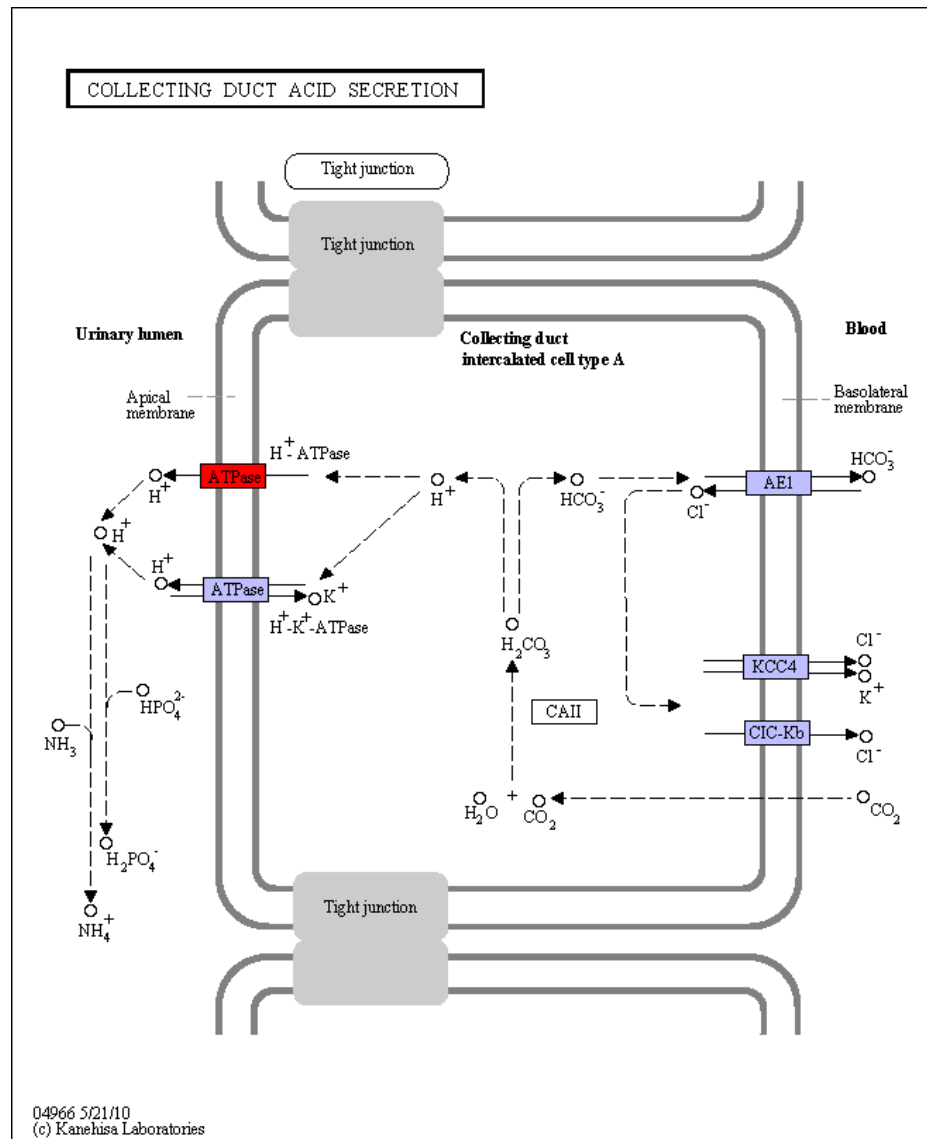

Figure 146: ko04966 Collecting duct acid secretion



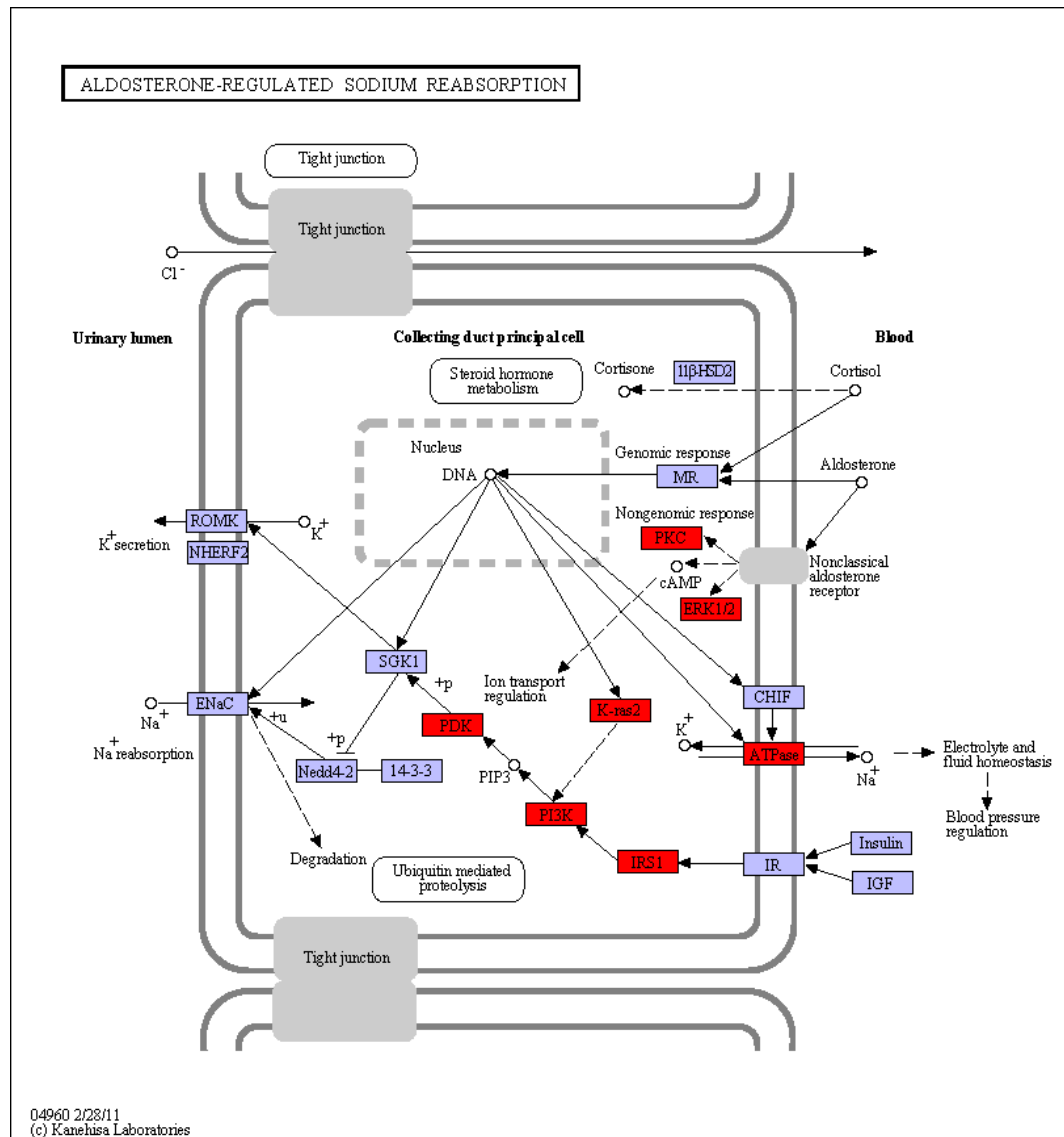

Figure 148: ko04960 Aldosterone-regulated sodium reabsorption

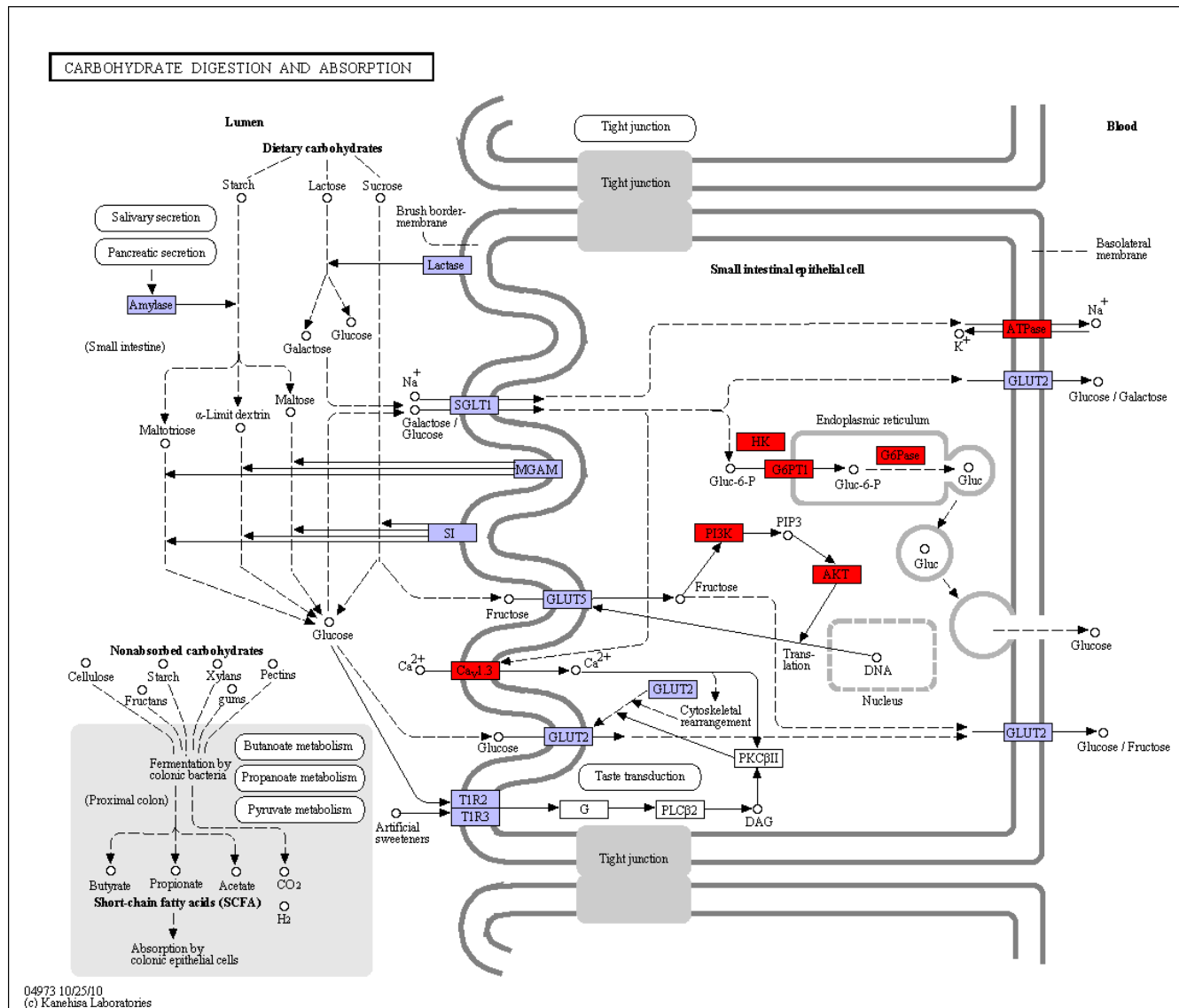

Figure 149: ko04973 Carbohydrate digestion and absorption

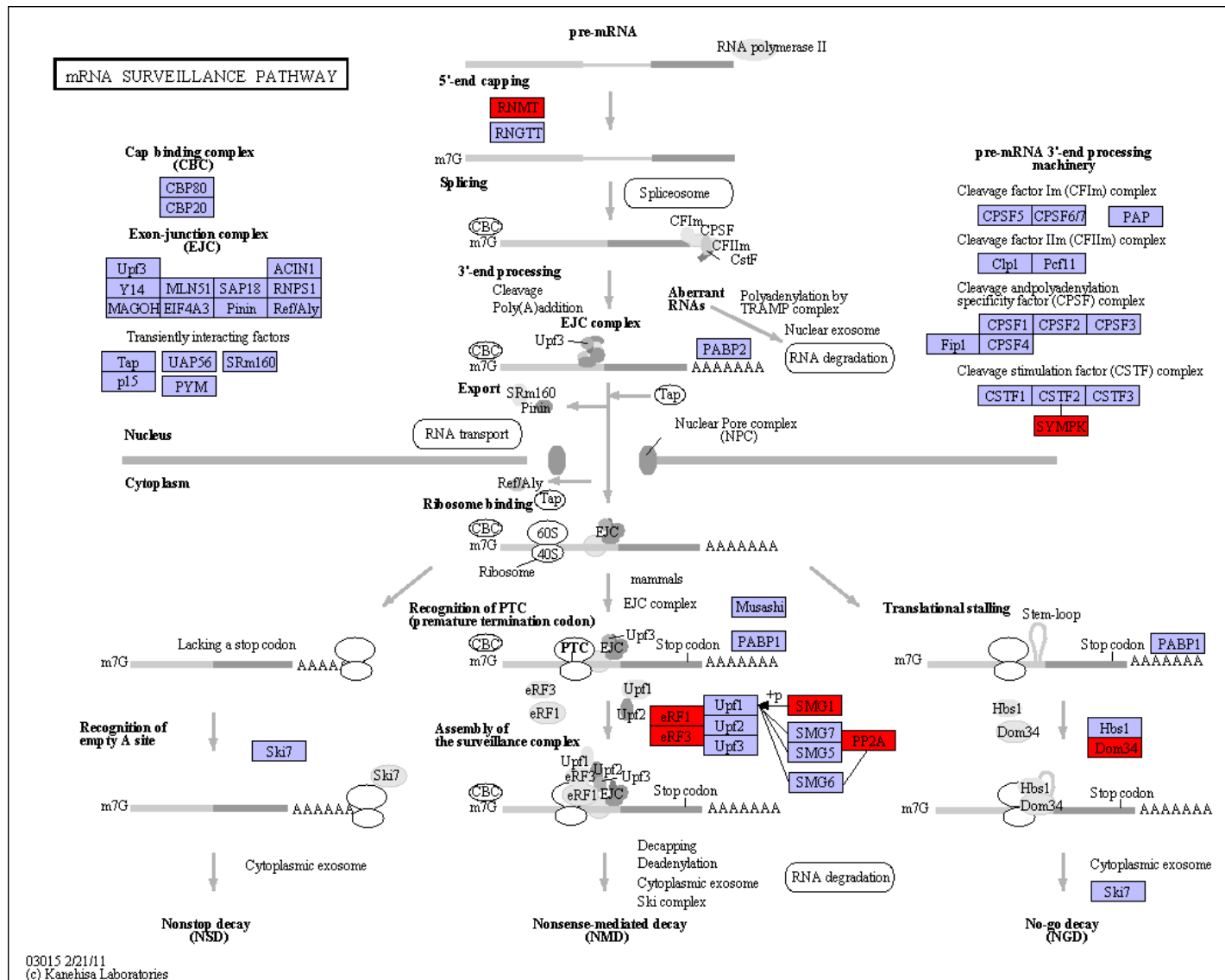

Figure 150: ko03015 mRNA surveillance pathway





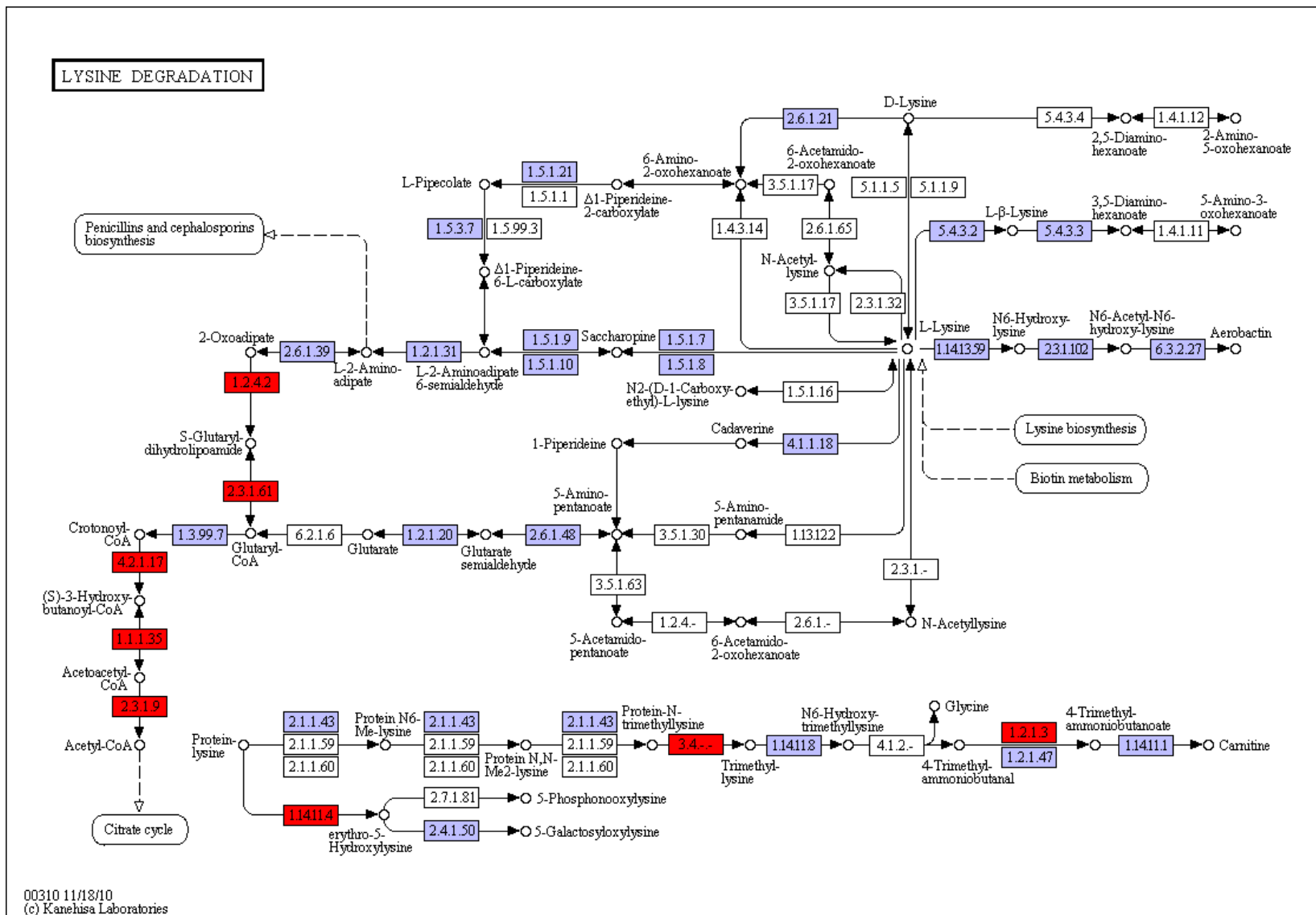

Figure 152: ko00310 Lysine degradation

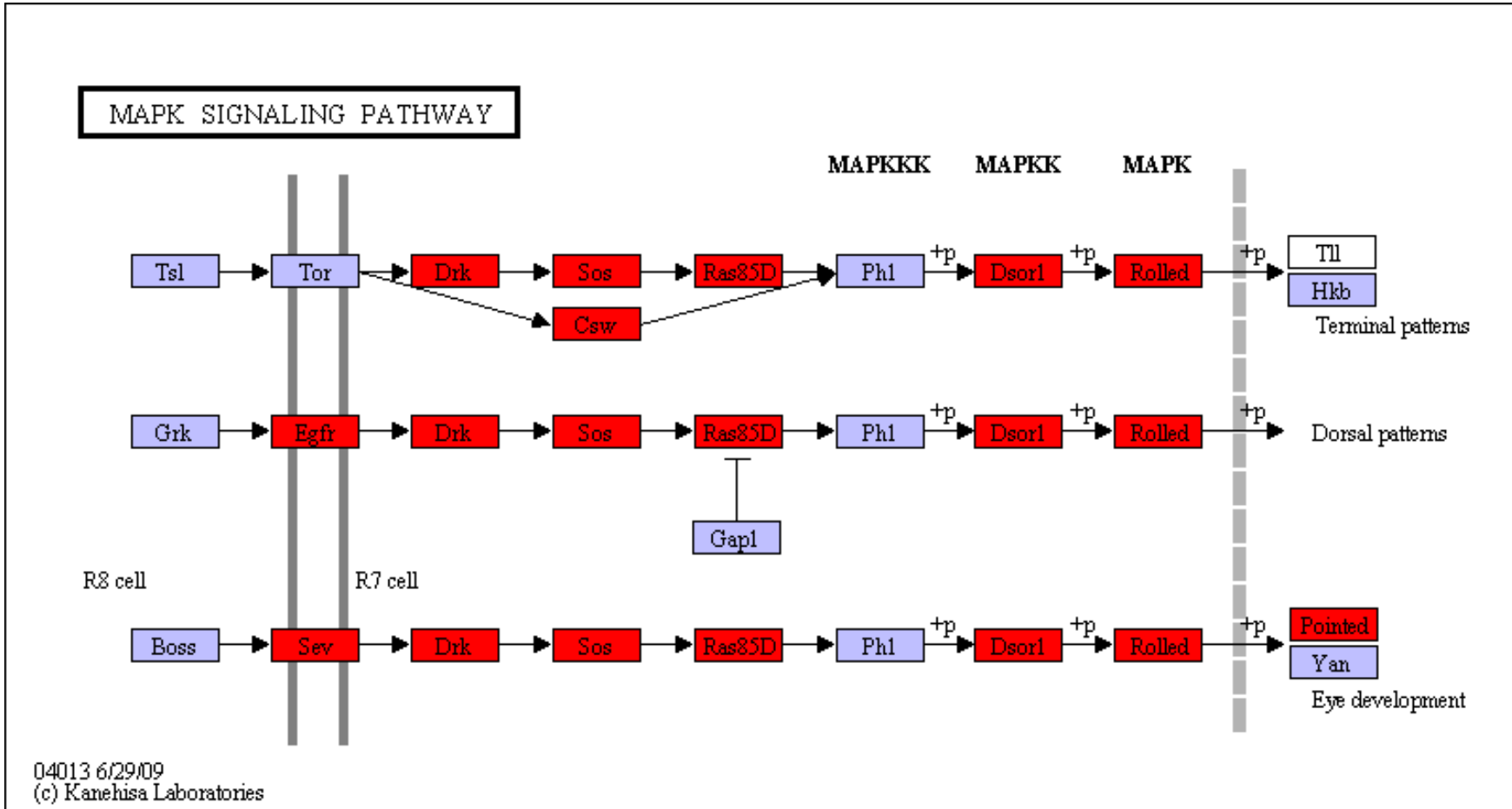
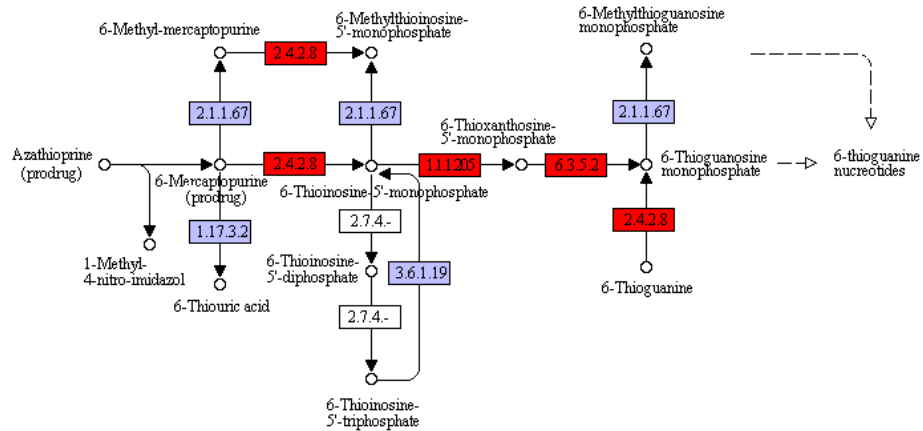

Figure 153: ko04013 MAPK signaling pathway - fly

DRUG METABOLISM - OTHER ENZYMES

Azathioprine & 6-Mercaptopurine



Irinotecan

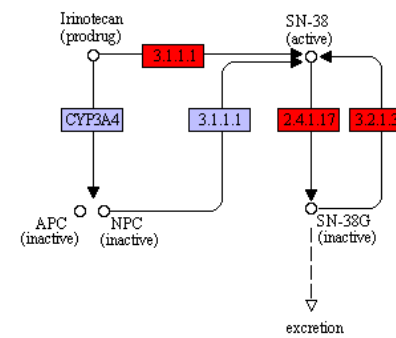

Fluorouracil

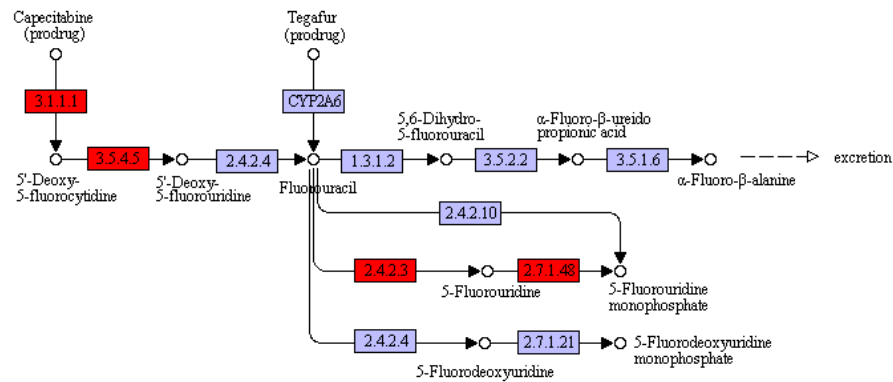

Isoniazid

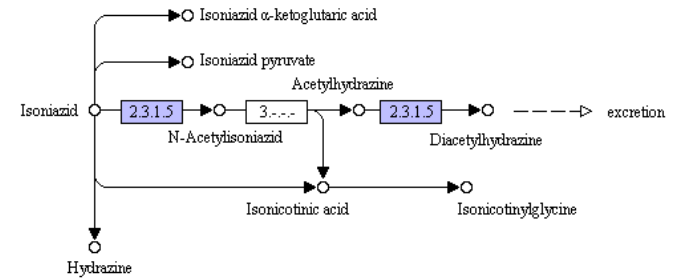

Figure 154: ko00983 Drug metabolism - other enzymes

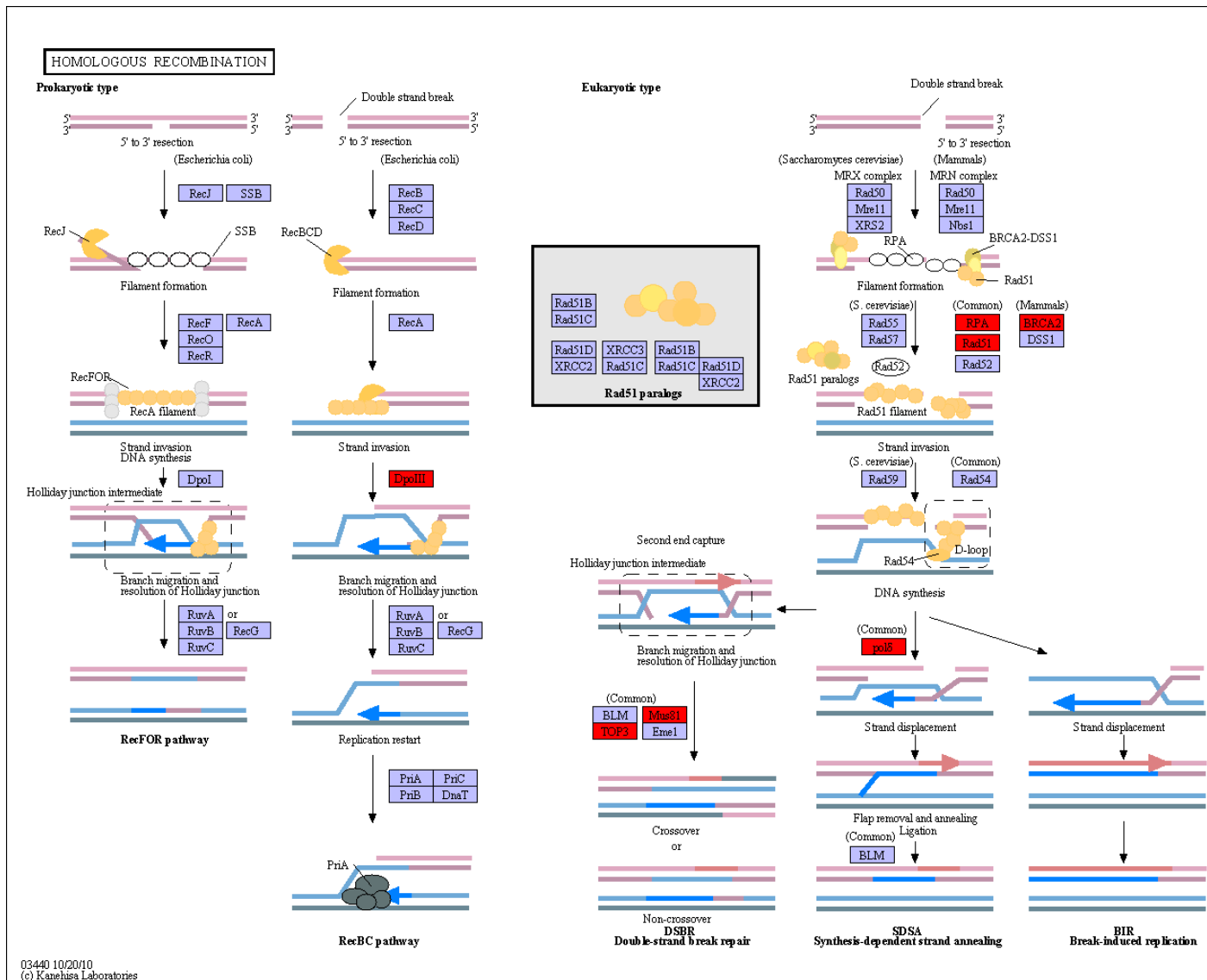

Figure 155: ko03440 Homologous recombination



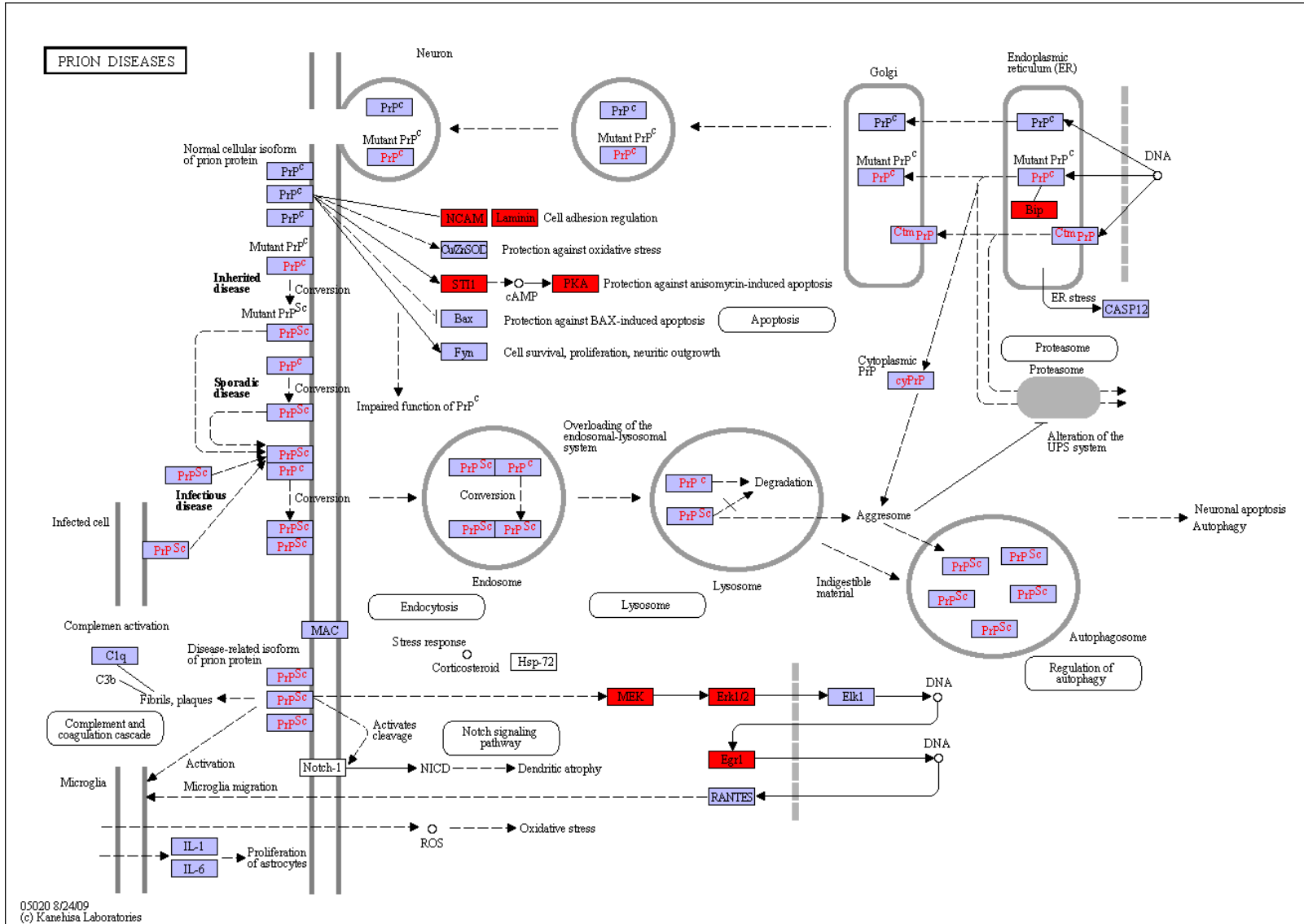

Figure 157: ko05020 Prion diseases



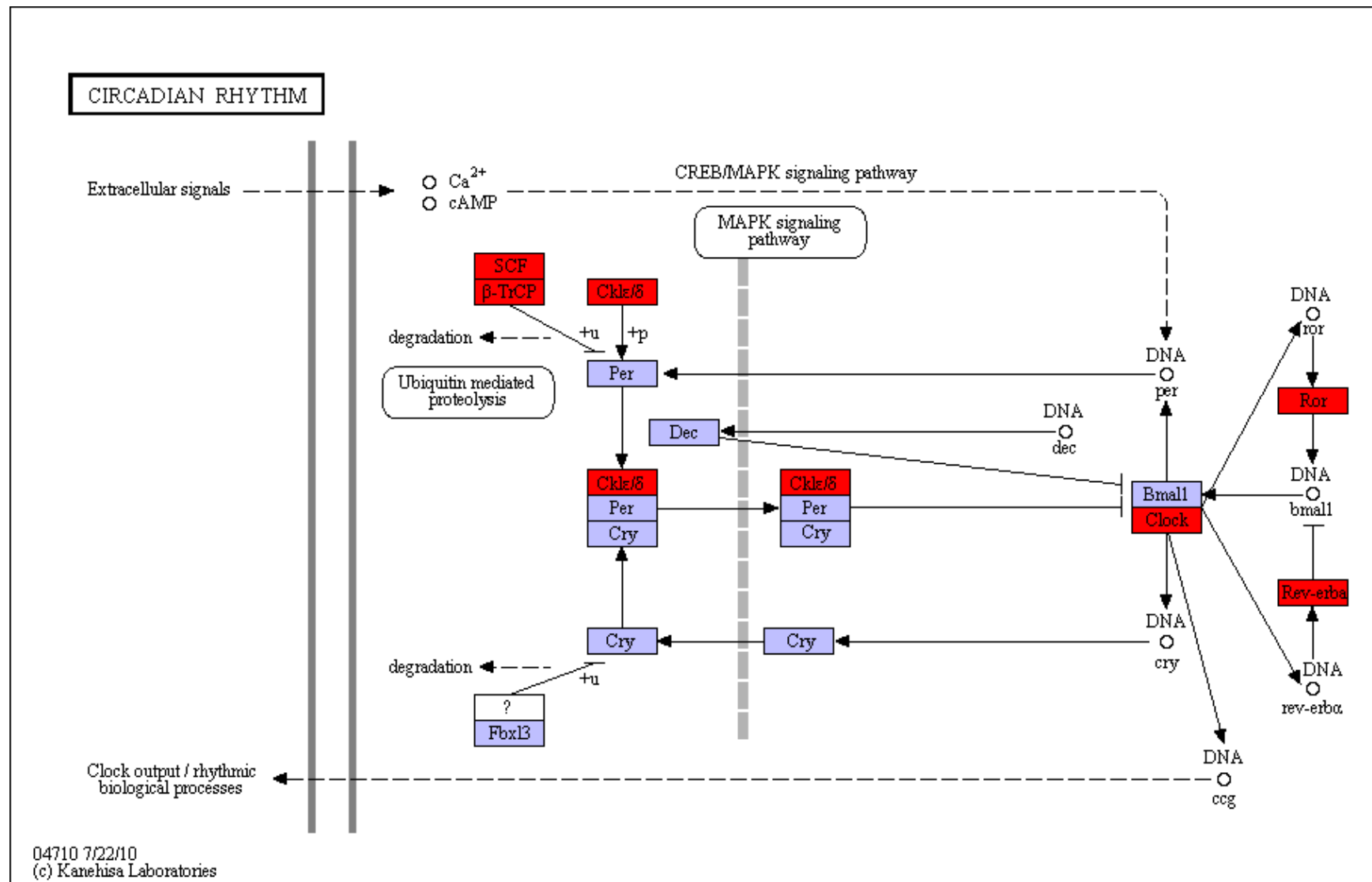

Figure 159: ko04710 Circadian rhythm - mammal



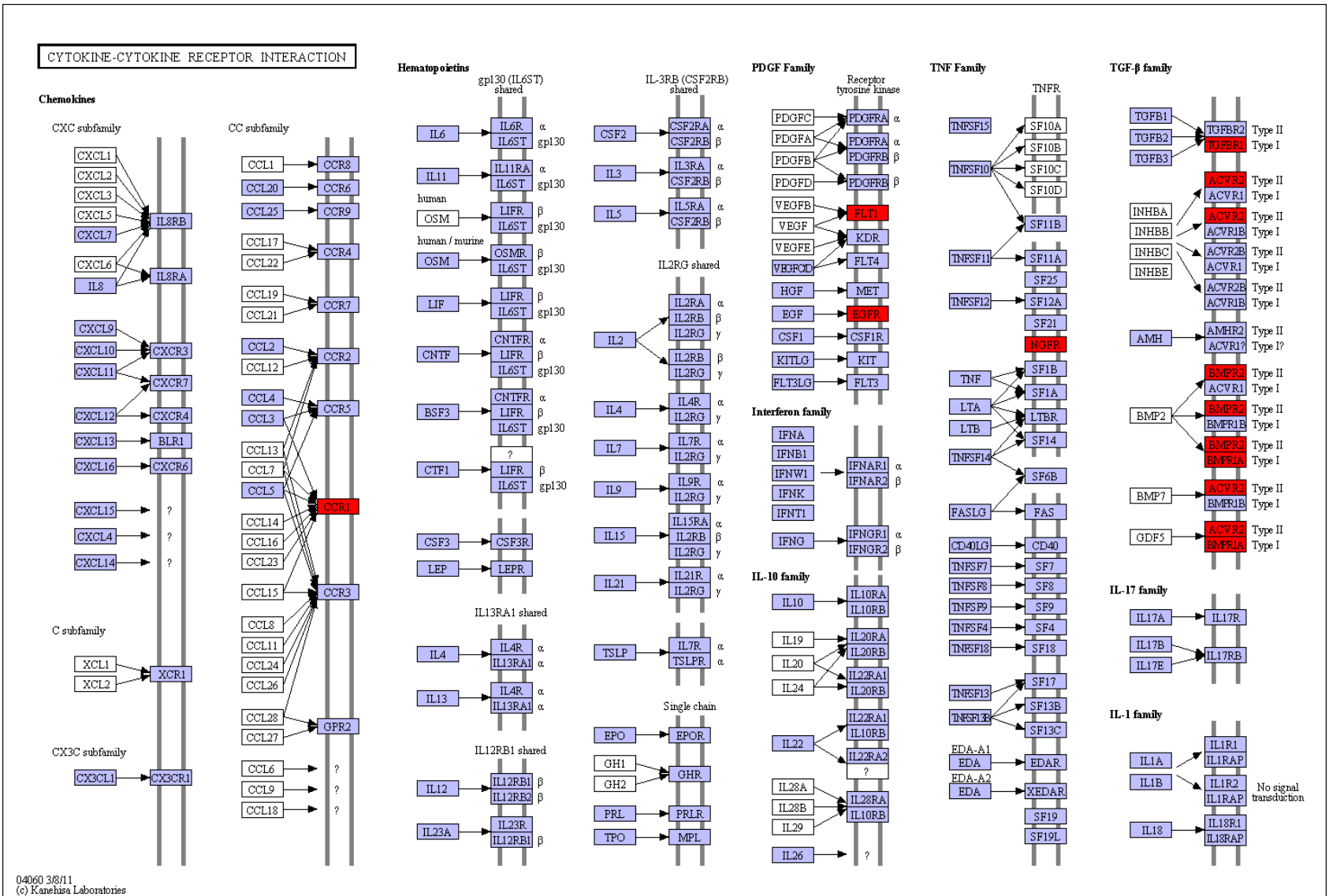

Figure 160: ko04060 Cytokine-cytokine receptor interaction

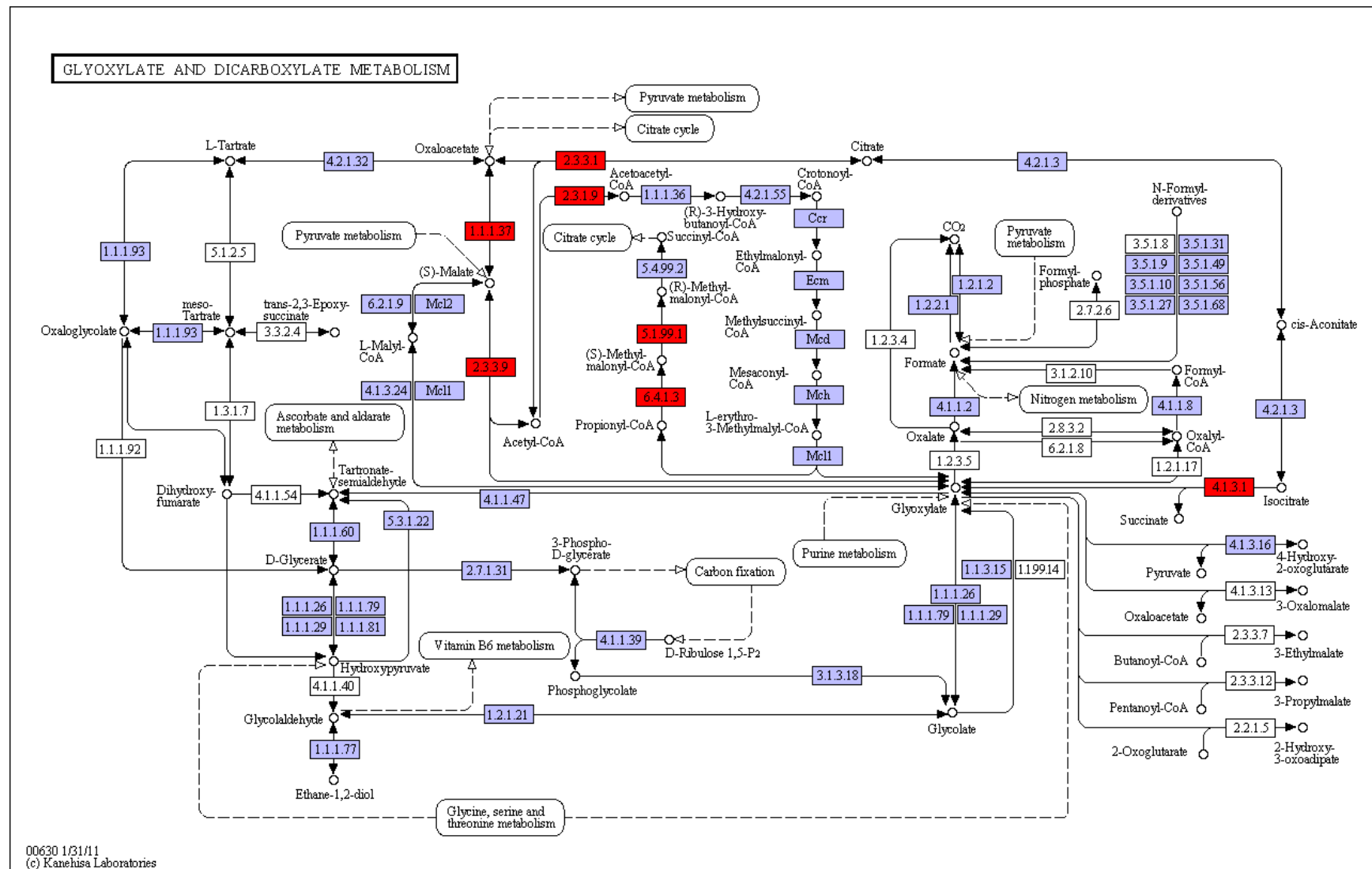

Figure 161: ko00630 Glyoxylate and dicarboxylate metabolism



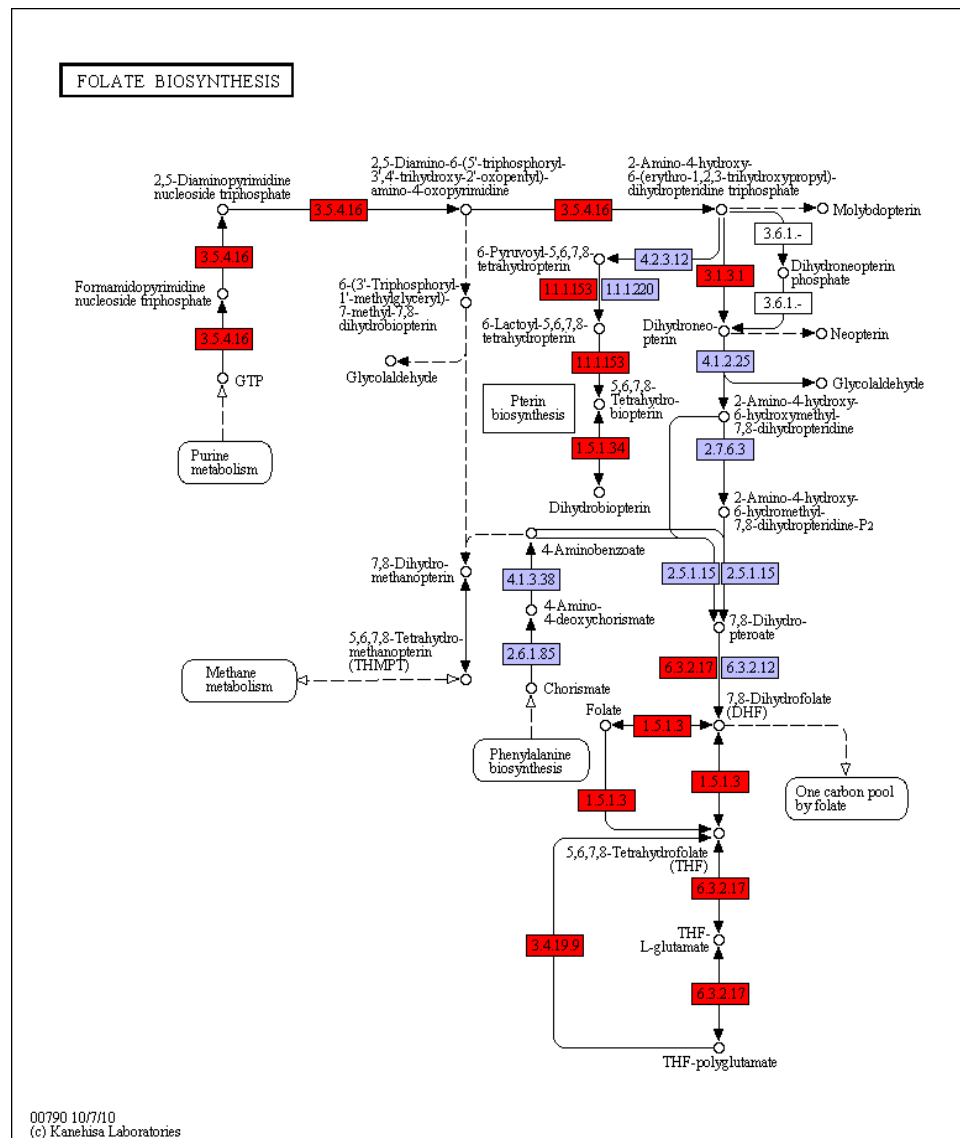

Figure 163: ko00790 Folate biosynthesis

OTHER TYPES OF O-GLYCAN BIOSYNTHESIS

**O-linked GlcNAc type**



**O-linked Man type**

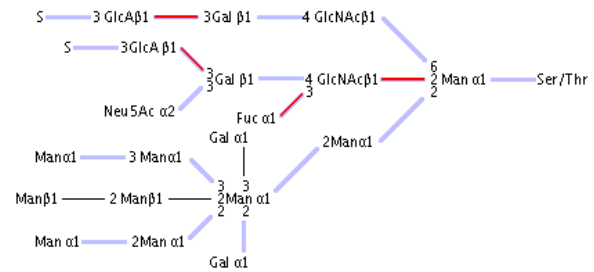

**O-linked Fuc type**

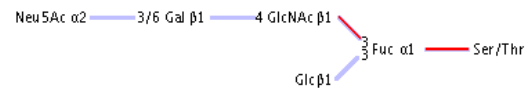

**O-linked Glc type**



**O-linked Gal type**

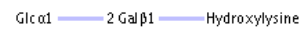

005141/24/11  
 (c) Kanehisa Laboratories

Figure 164: ko00514 Other types of O-glycan biosynthesis

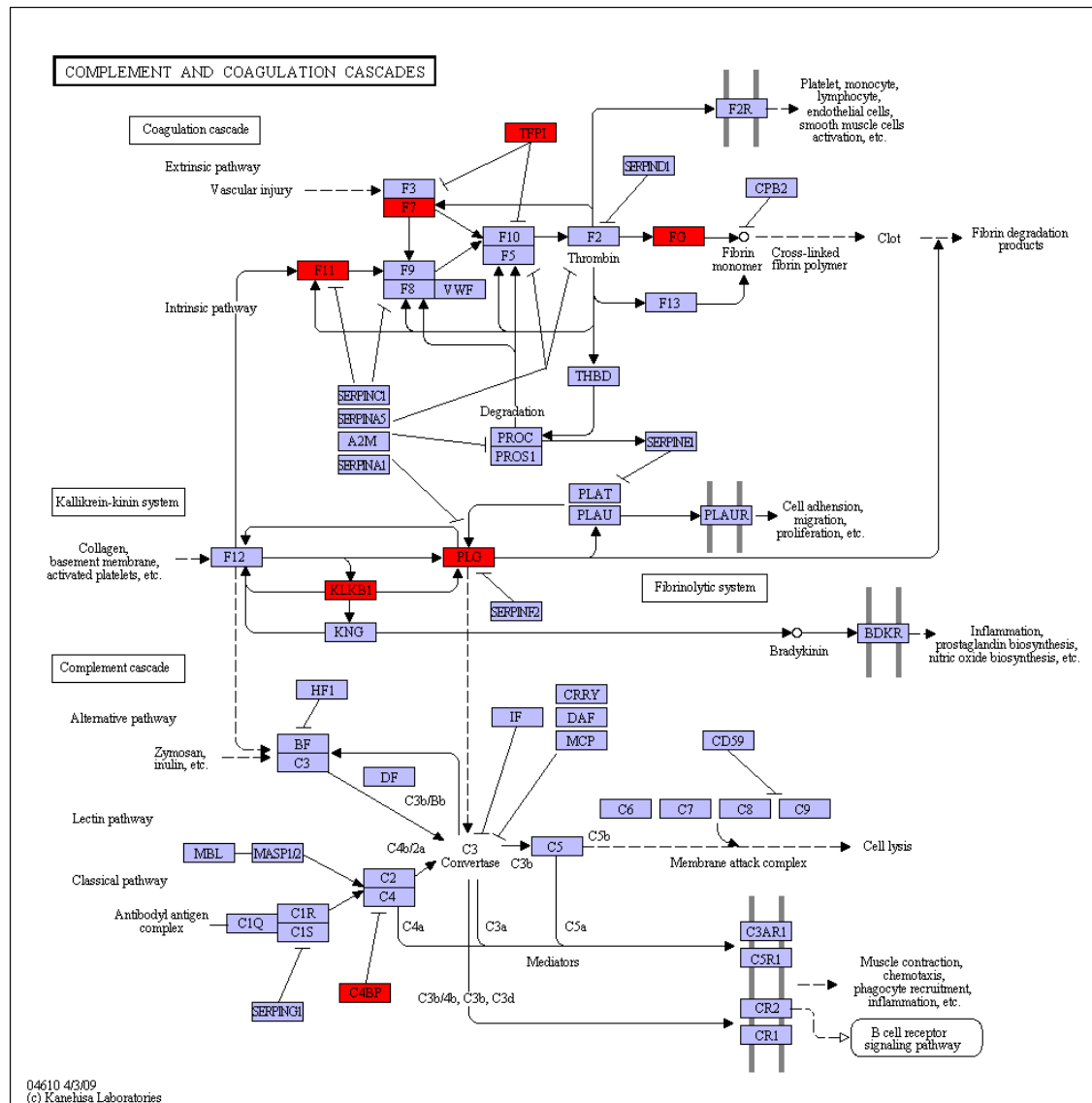

Figure 165: ko04610 Complement and coagulation cascades

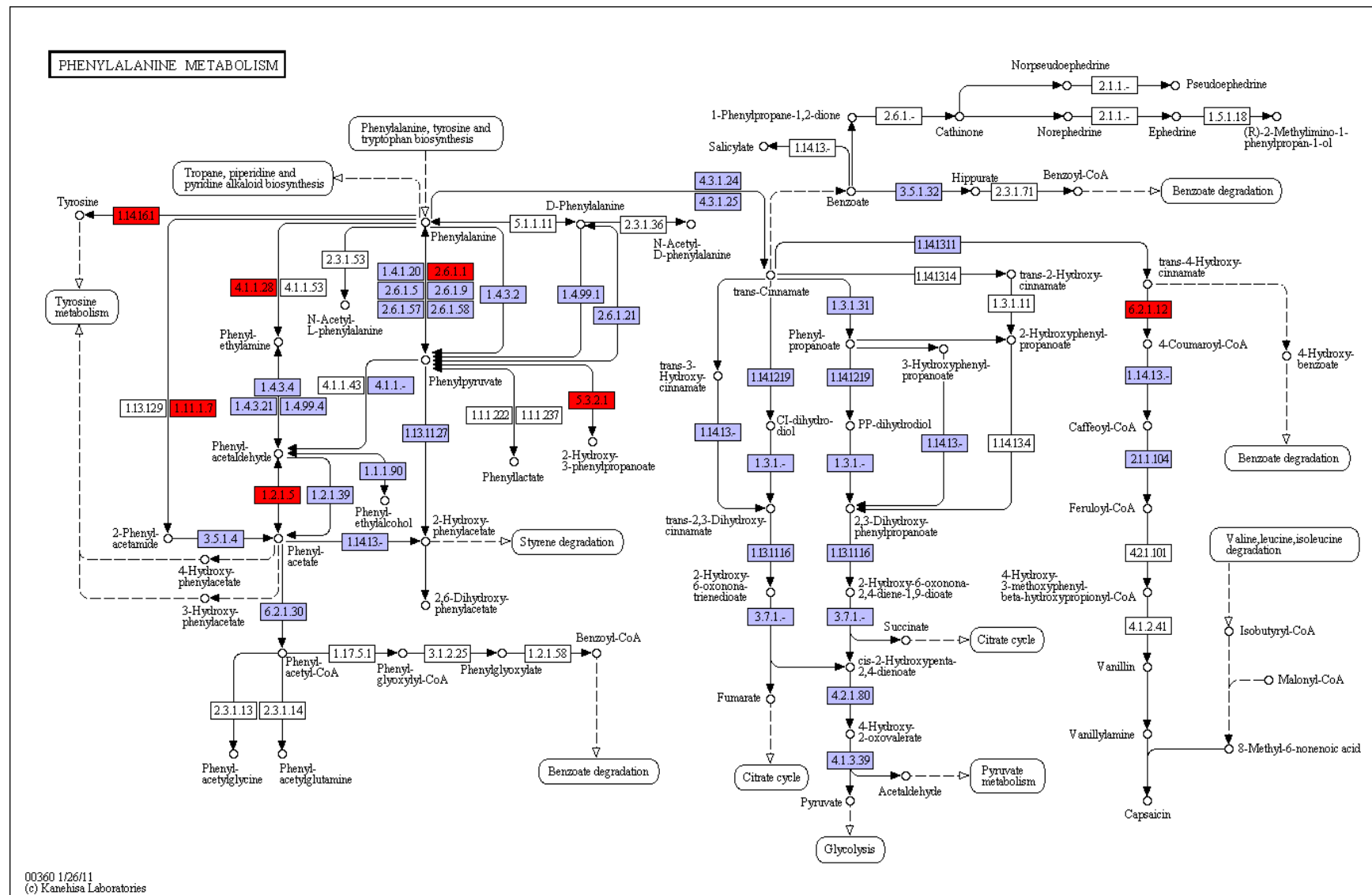

Figure 166: ko00360 Phenylalanine metabolism

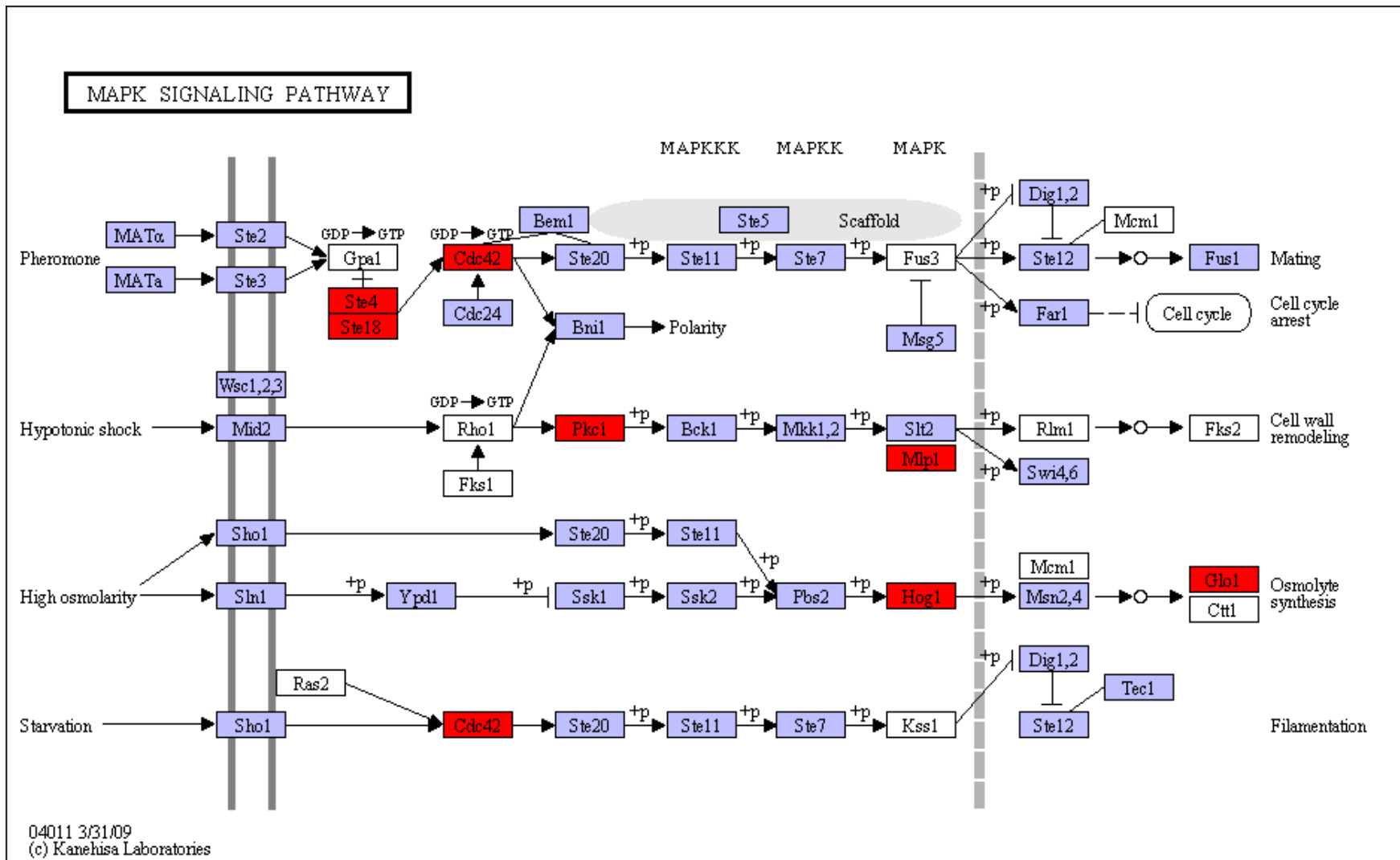

Figure 167: ko04011 MAPK signaling pathway - yeast



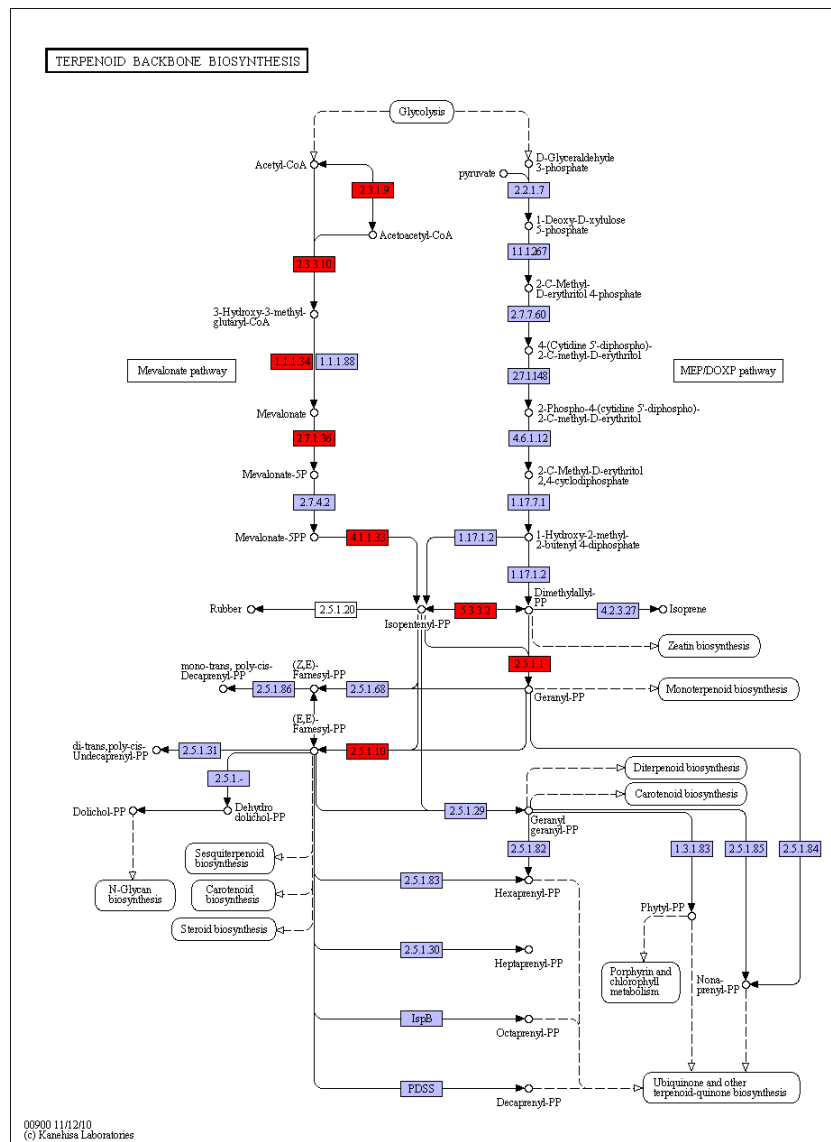

Figure 168: ko00900 Terpenoid backbone biosynthesis

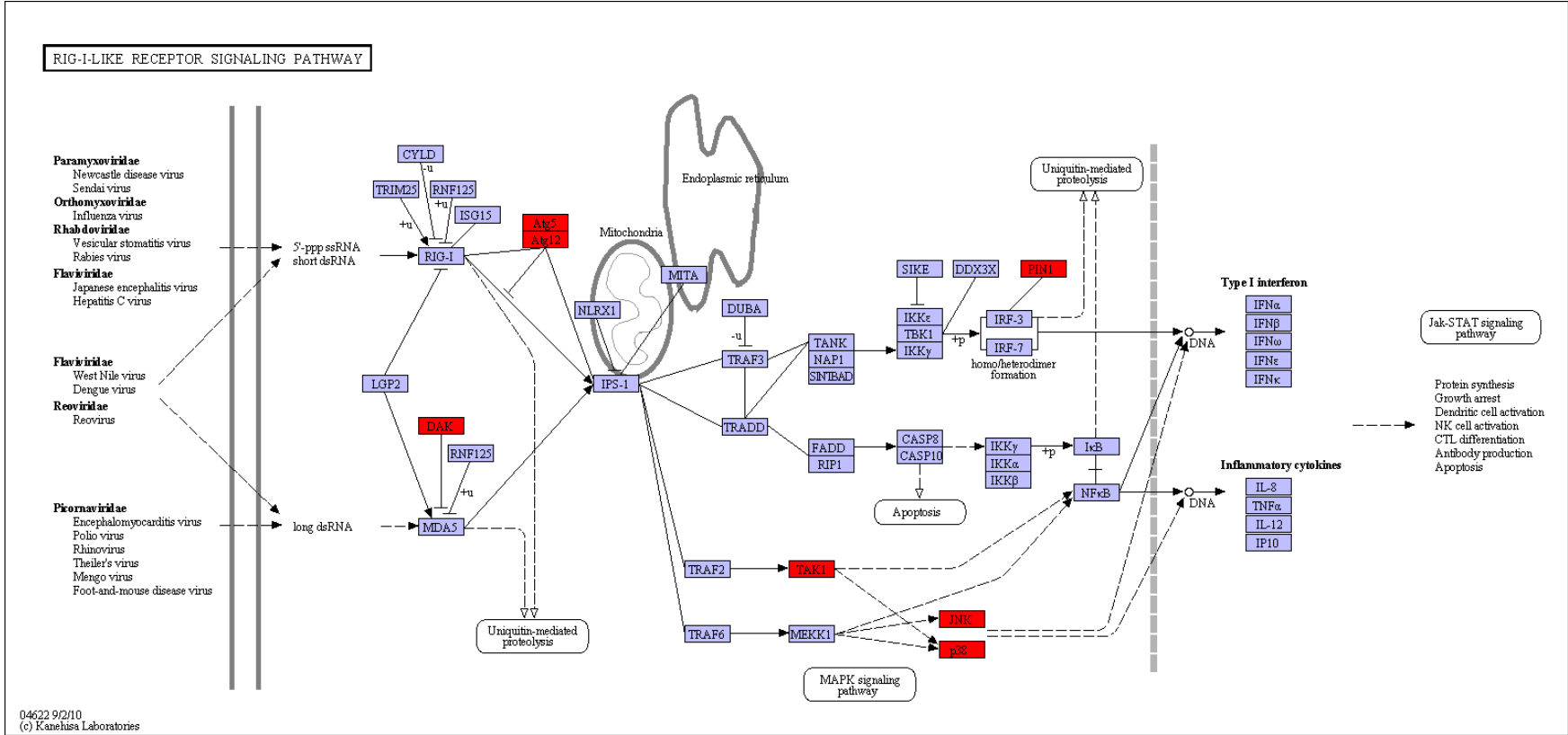

Figure 169: ko04622 RIG-I-like receptor signaling pathway

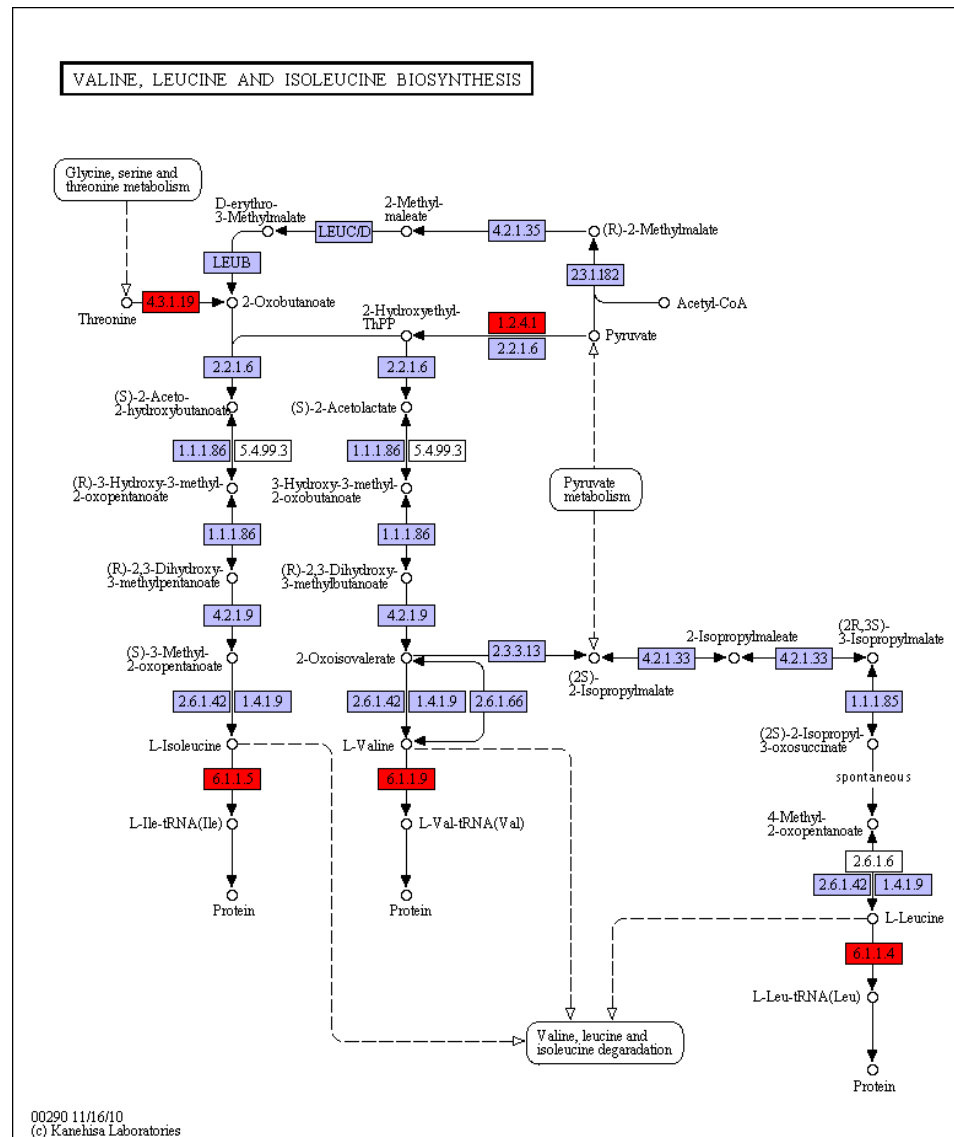

Figure 170: ko00290 Valine, leucine and isoleucine biosynthesis

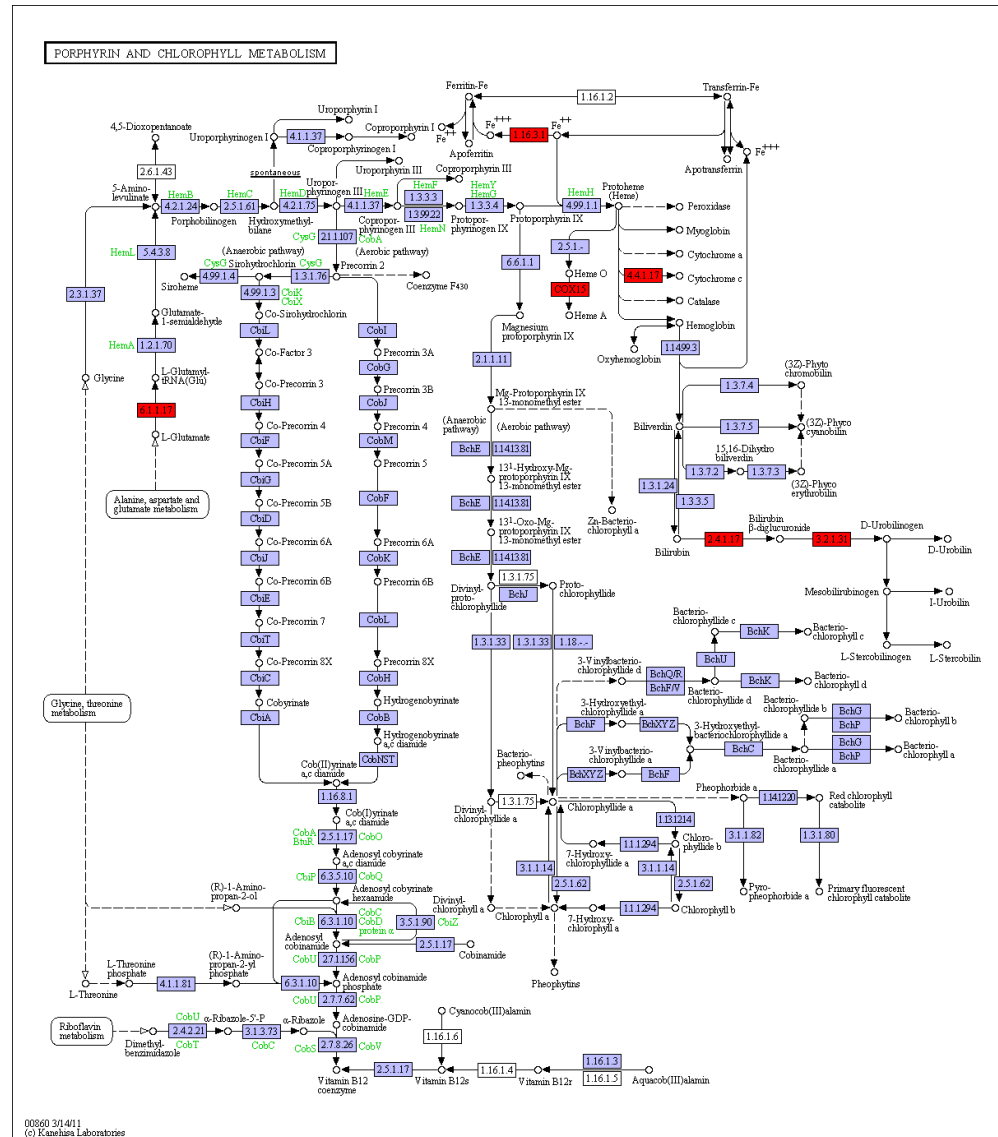

Figure 171: ko00860 Porphyrin and chlorophyll metabolism



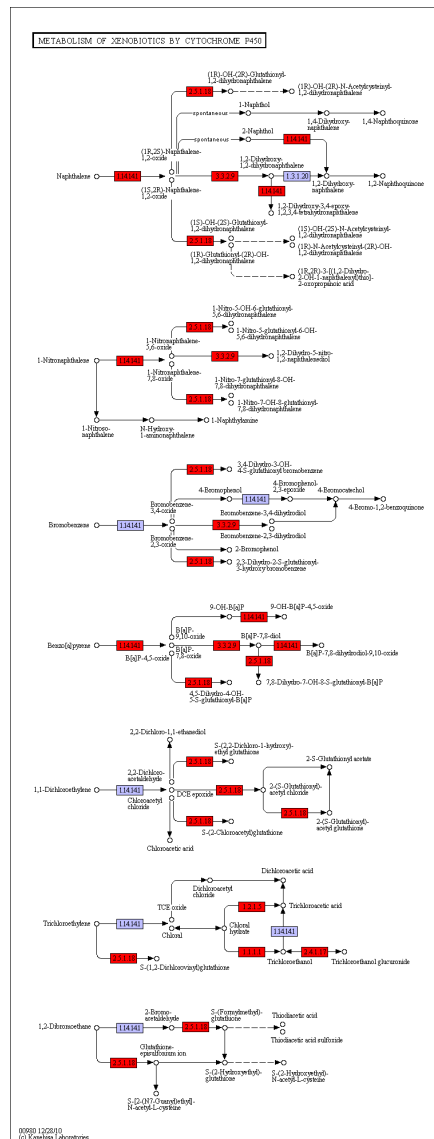

Figure 173: ko00980 Metabolism of xenobiotics by cytochrome P450



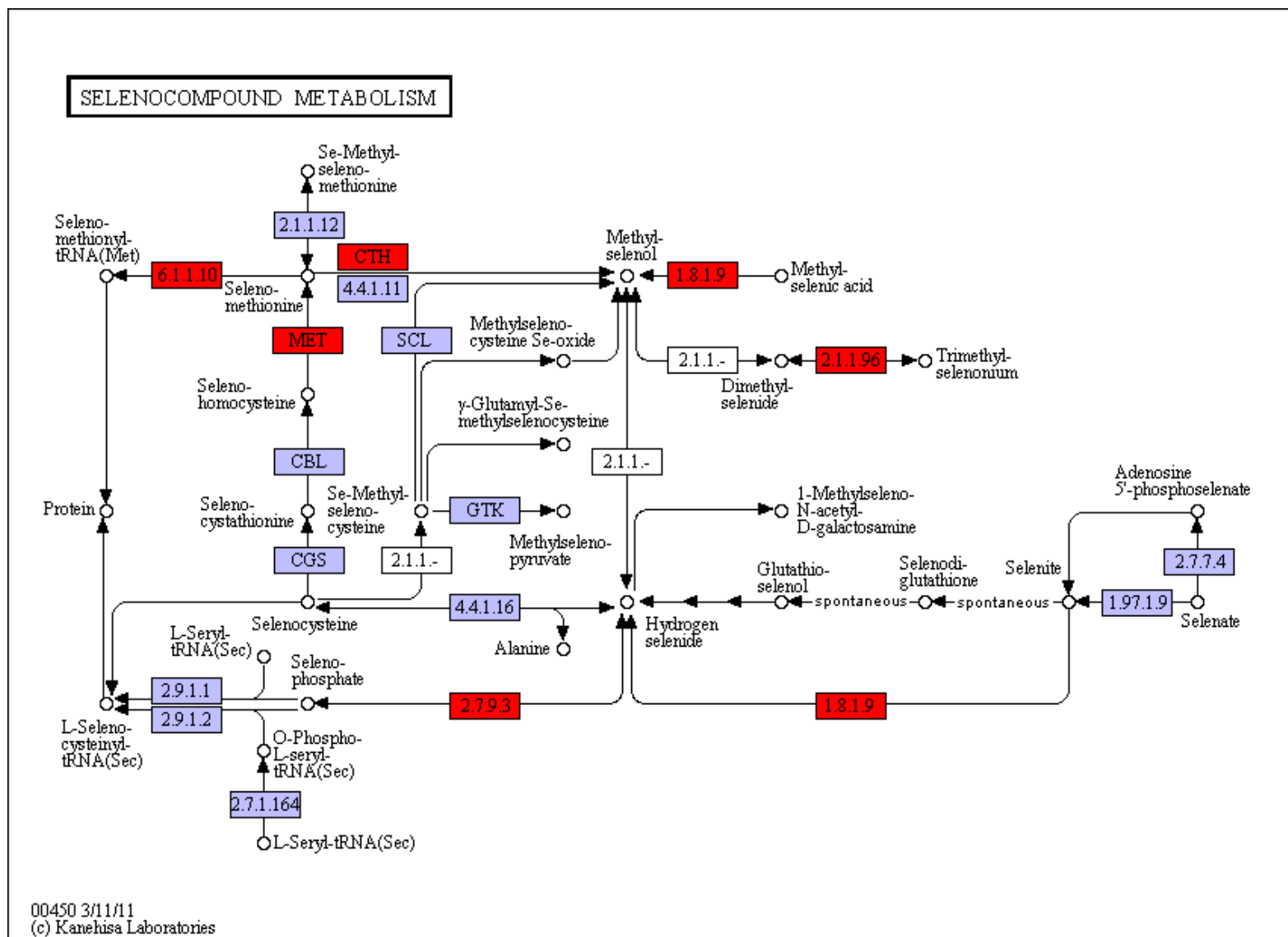

Figure 175: ko00450 Selenocompound metabolism



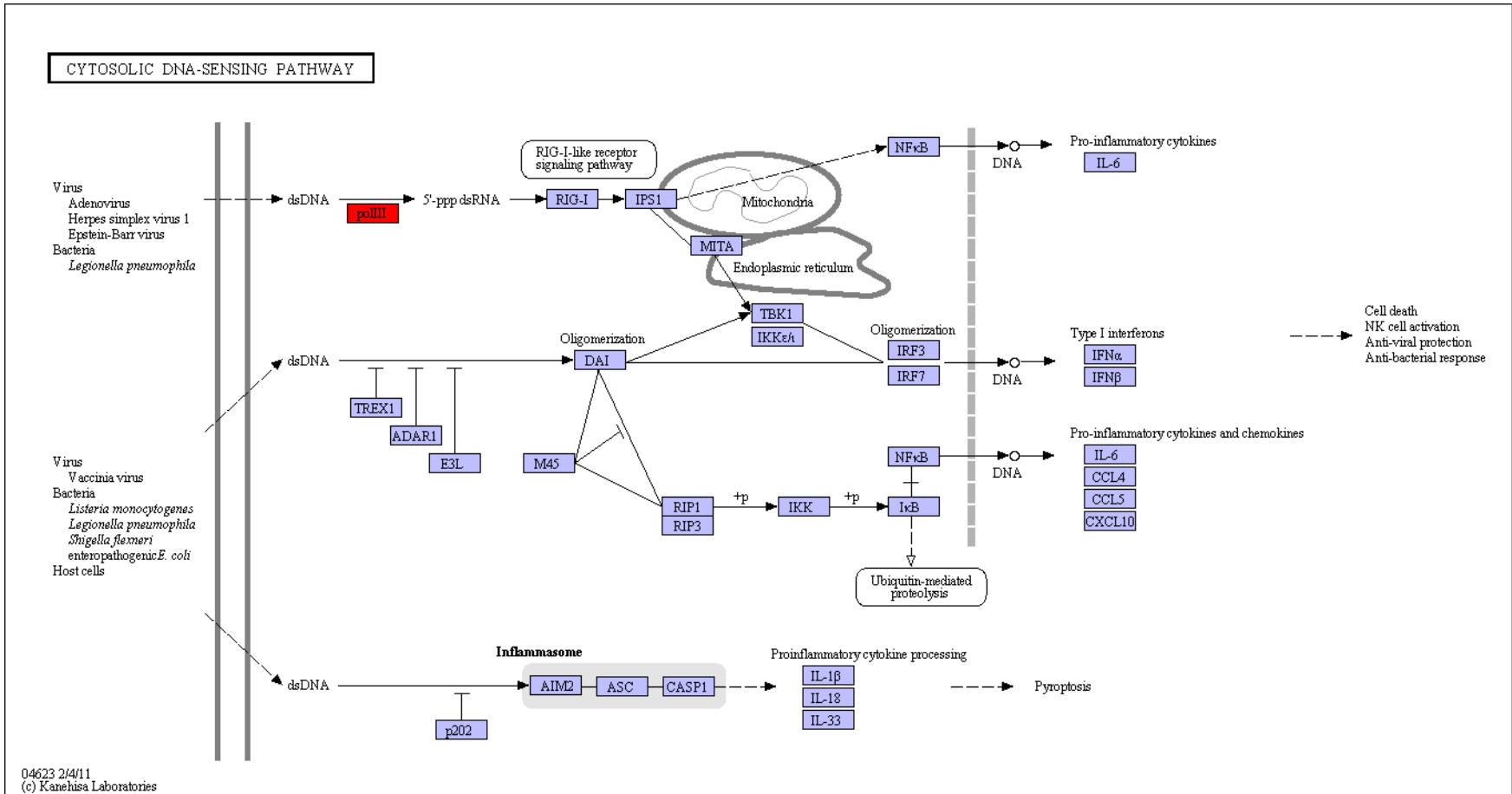

Figure 176: ko04623 Cytosolic DNA-sensing pathway

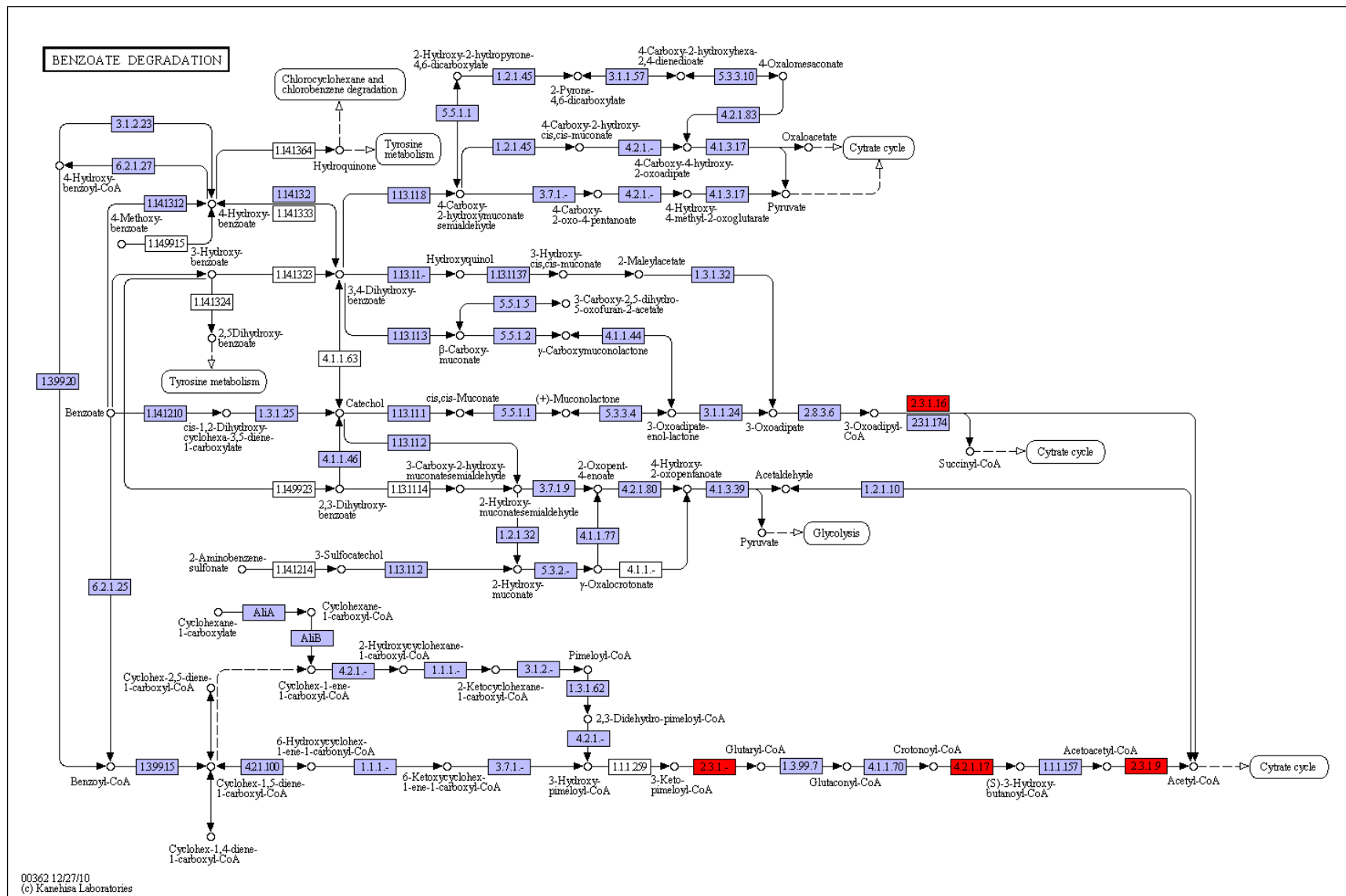
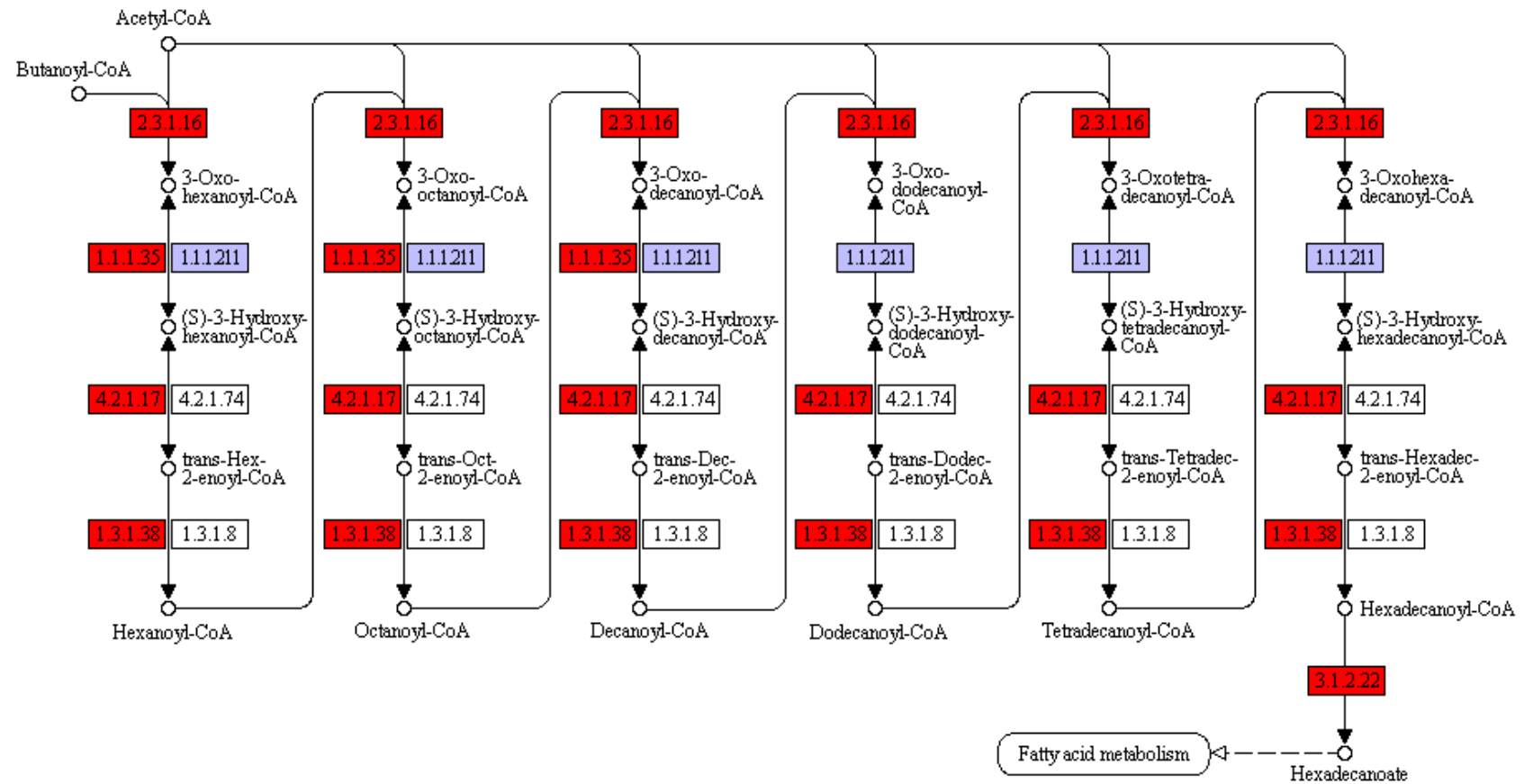

Figure 177: ko00362 Benzoate degradation

FATTY ACID ELONGATION IN MITOCHONDRIA



00062 2/22/10  
 (c) Kanehisa Laboratories

Figure 178: ko00062 Fatty acid elongation in mitochondria

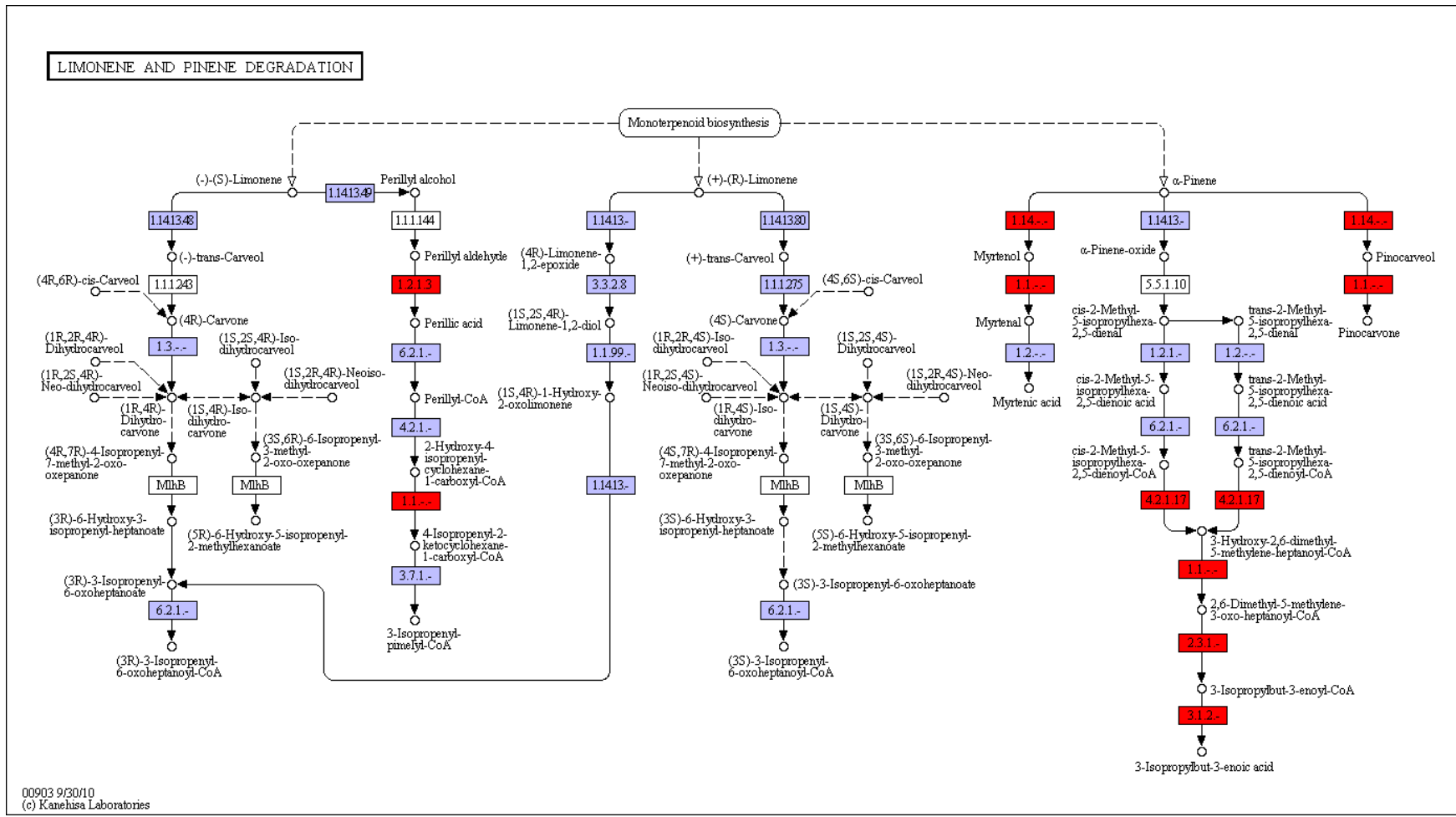

Figure 179: ko00903 Limonene and pinene degradation

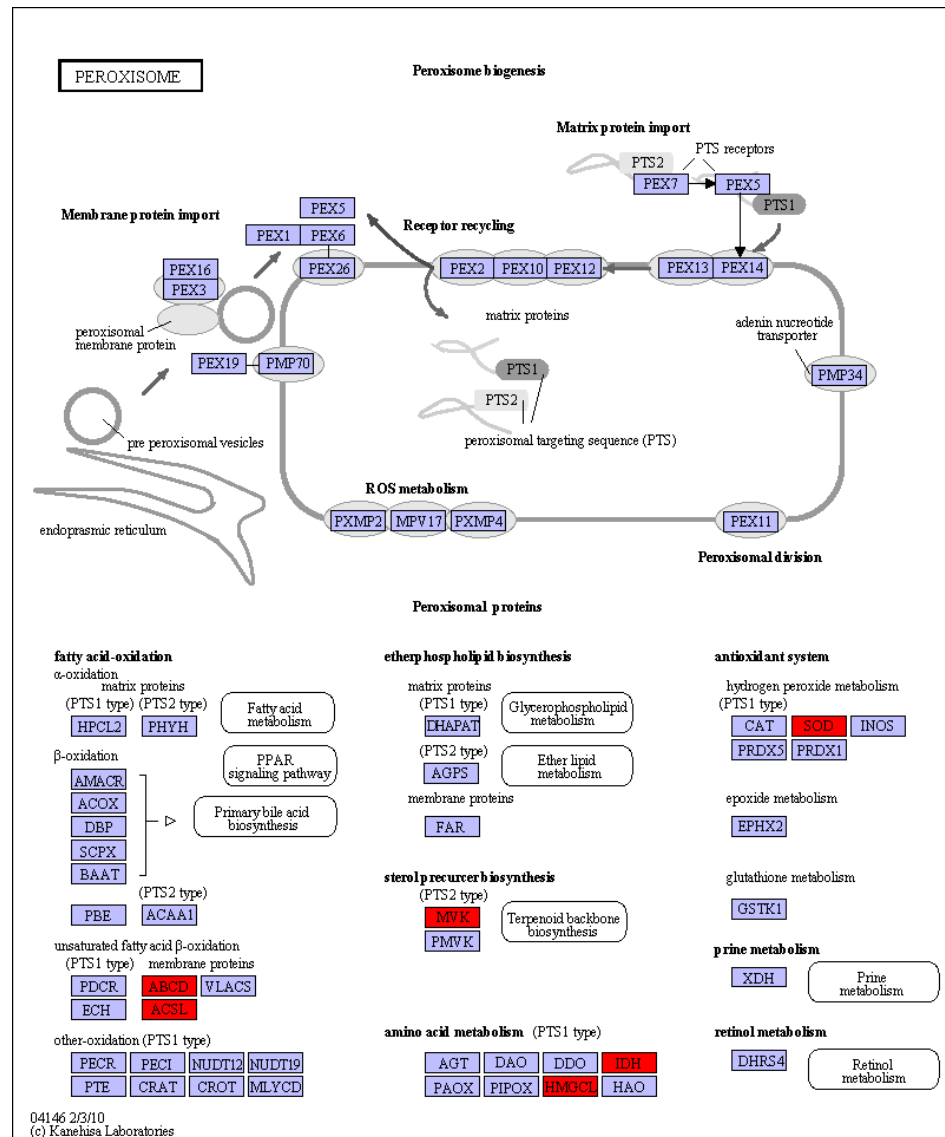

Figure 180: ko04146 Peroxisome

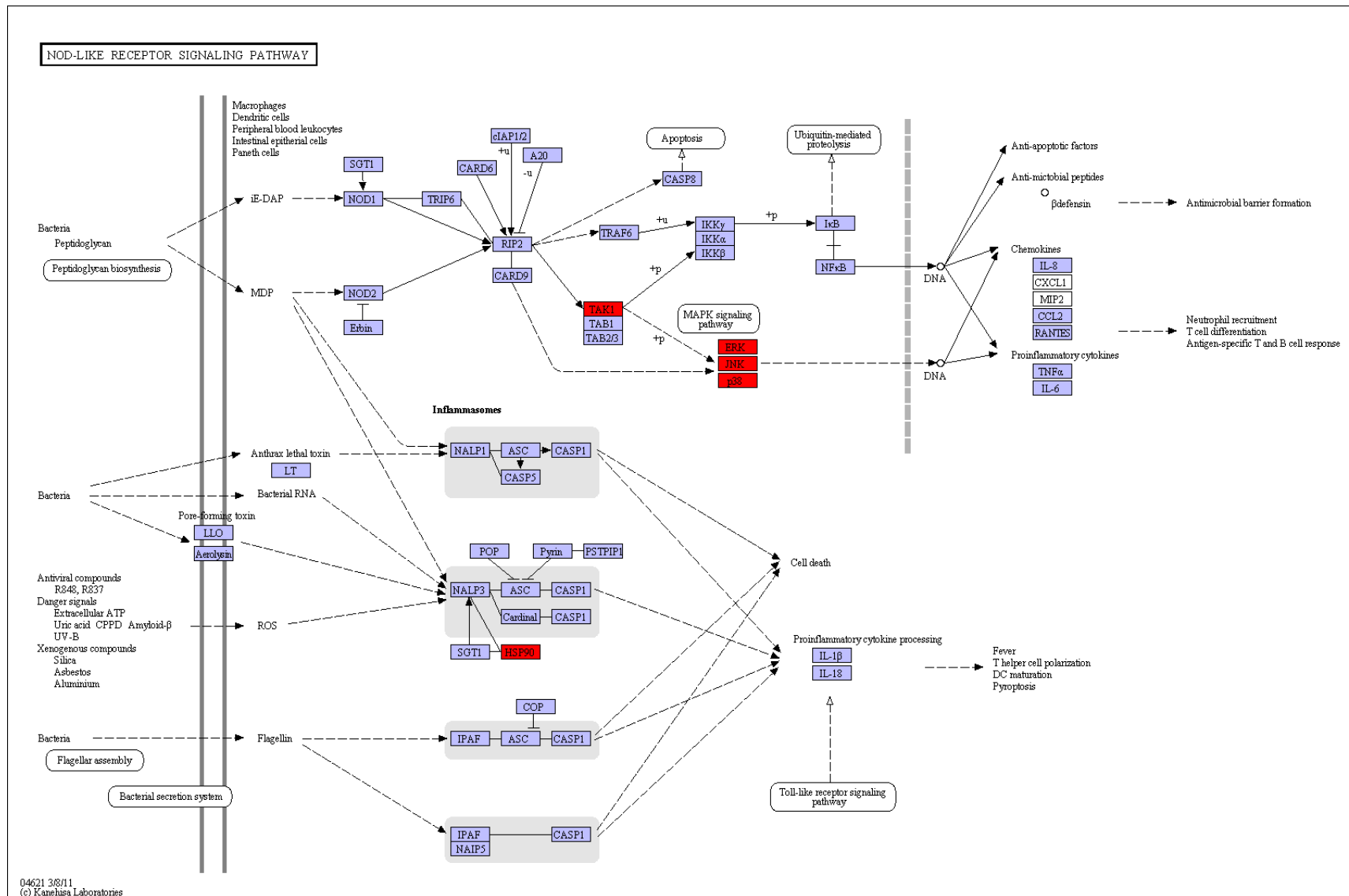

Figure 181: ko04621 NOD-like receptor signaling pathway

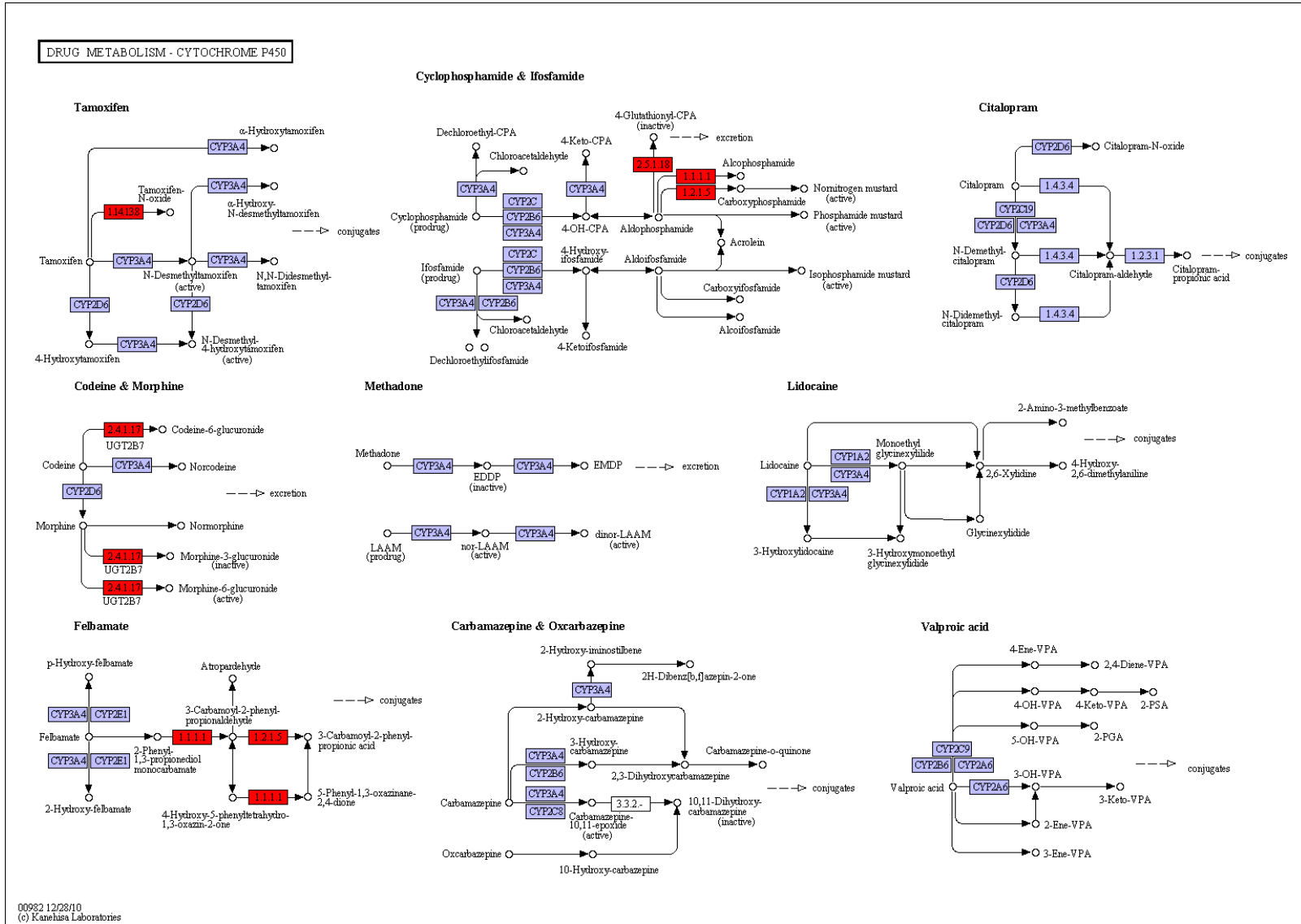

Figure 182: ko00982 Drug metabolism - cytochrome P450











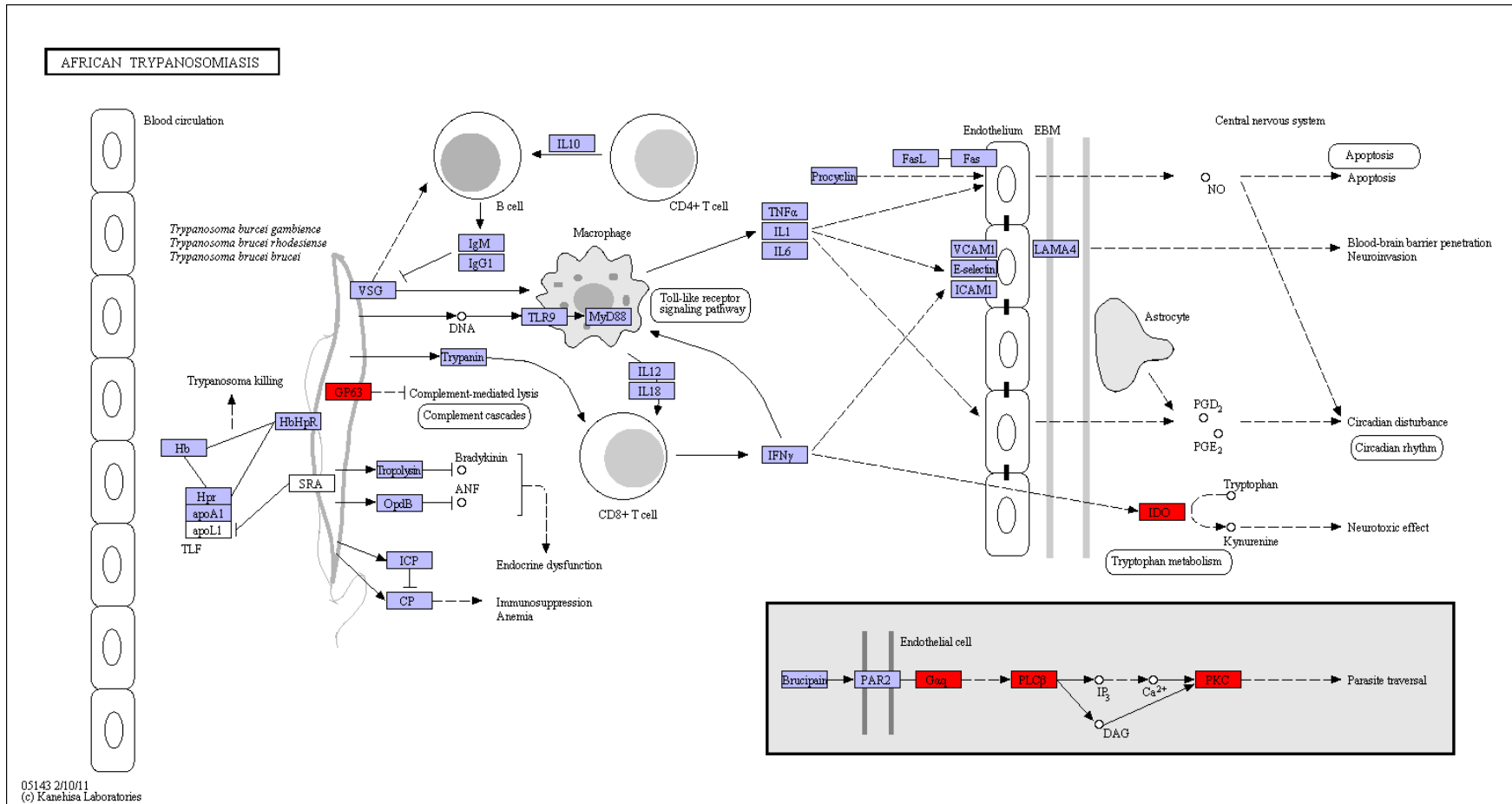

Figure 187: ko05143 African trypanosomiasis

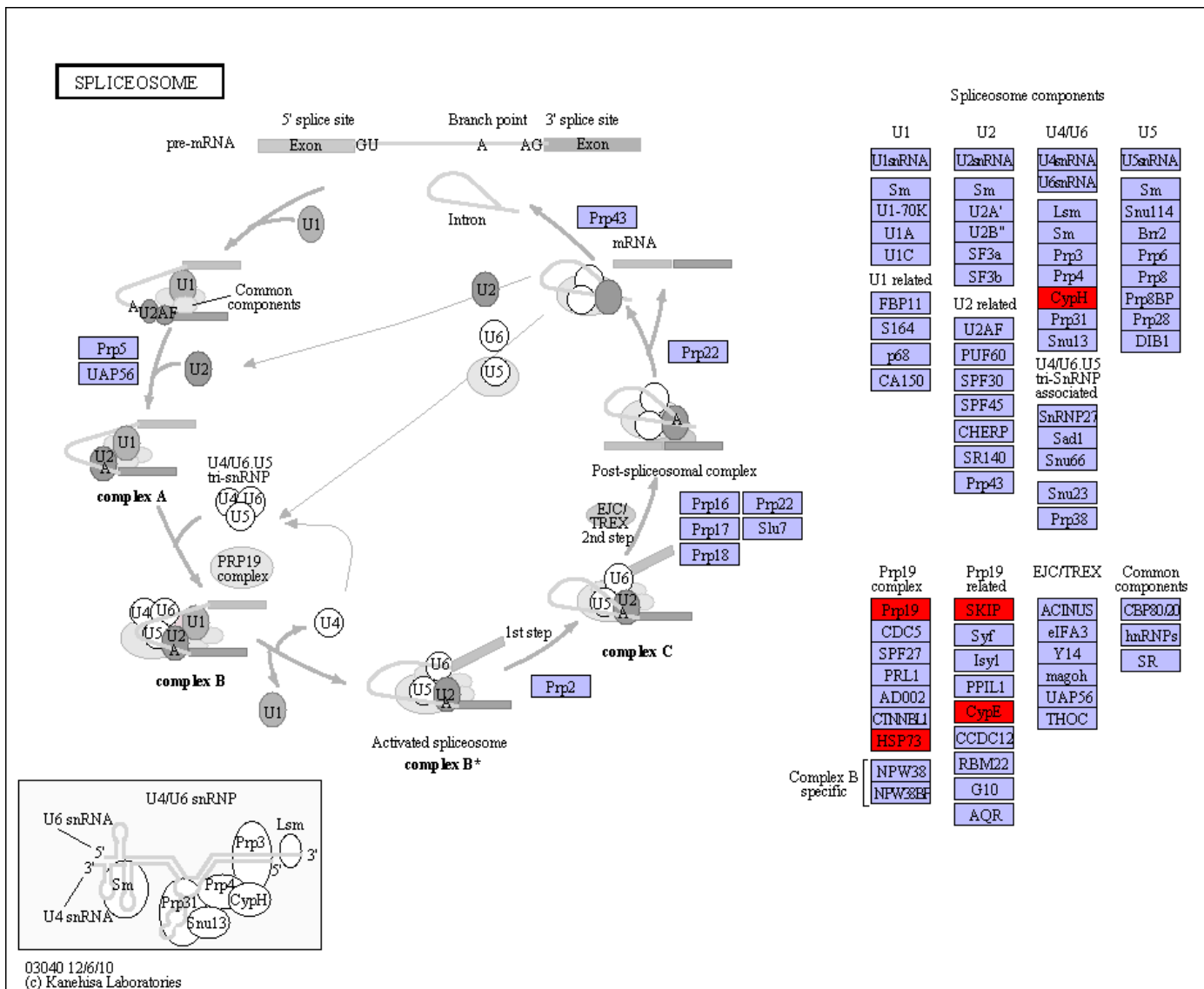

Figure 188: ko03040 Spliceosome

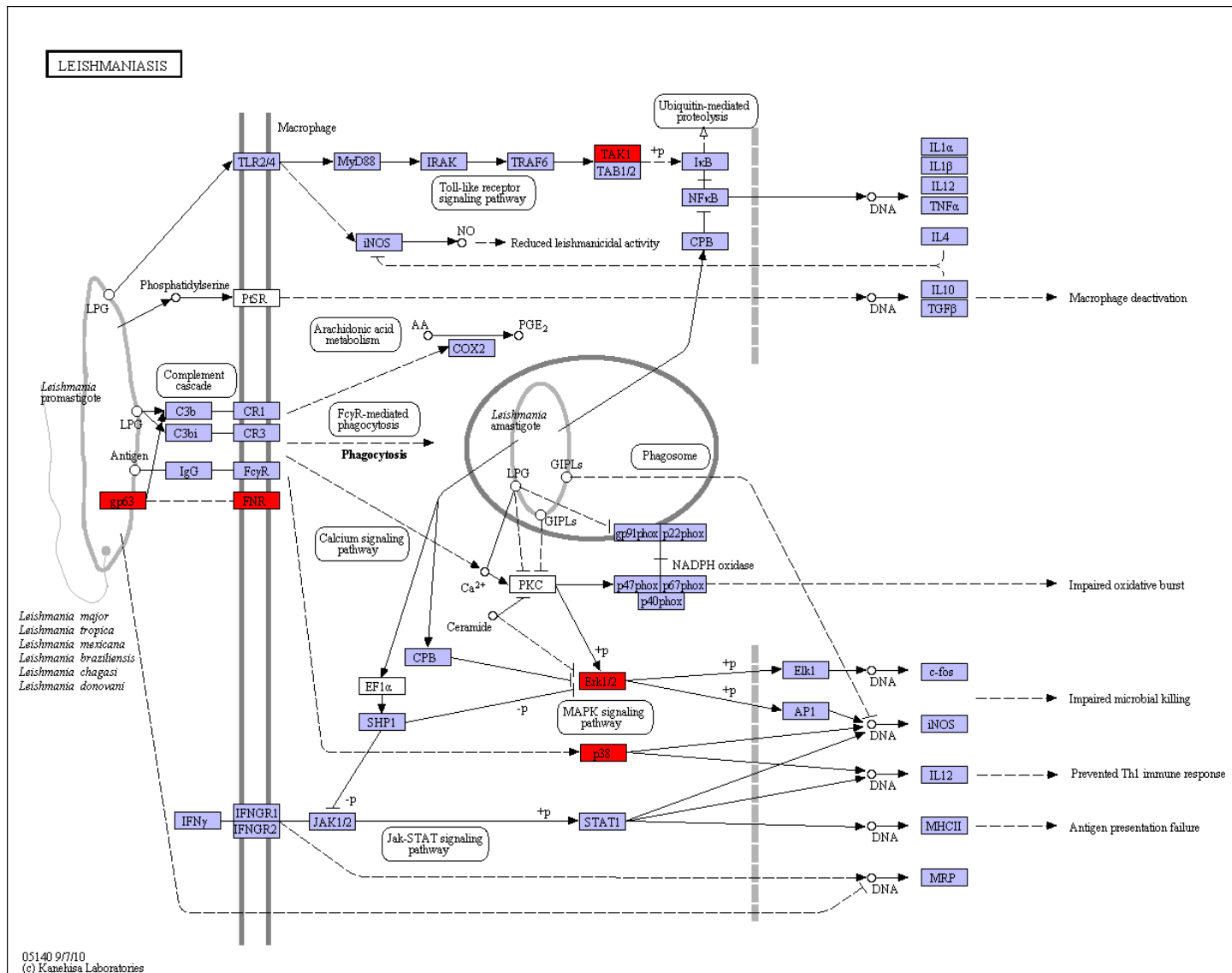

Figure 189: ko05140 Leishmaniasis

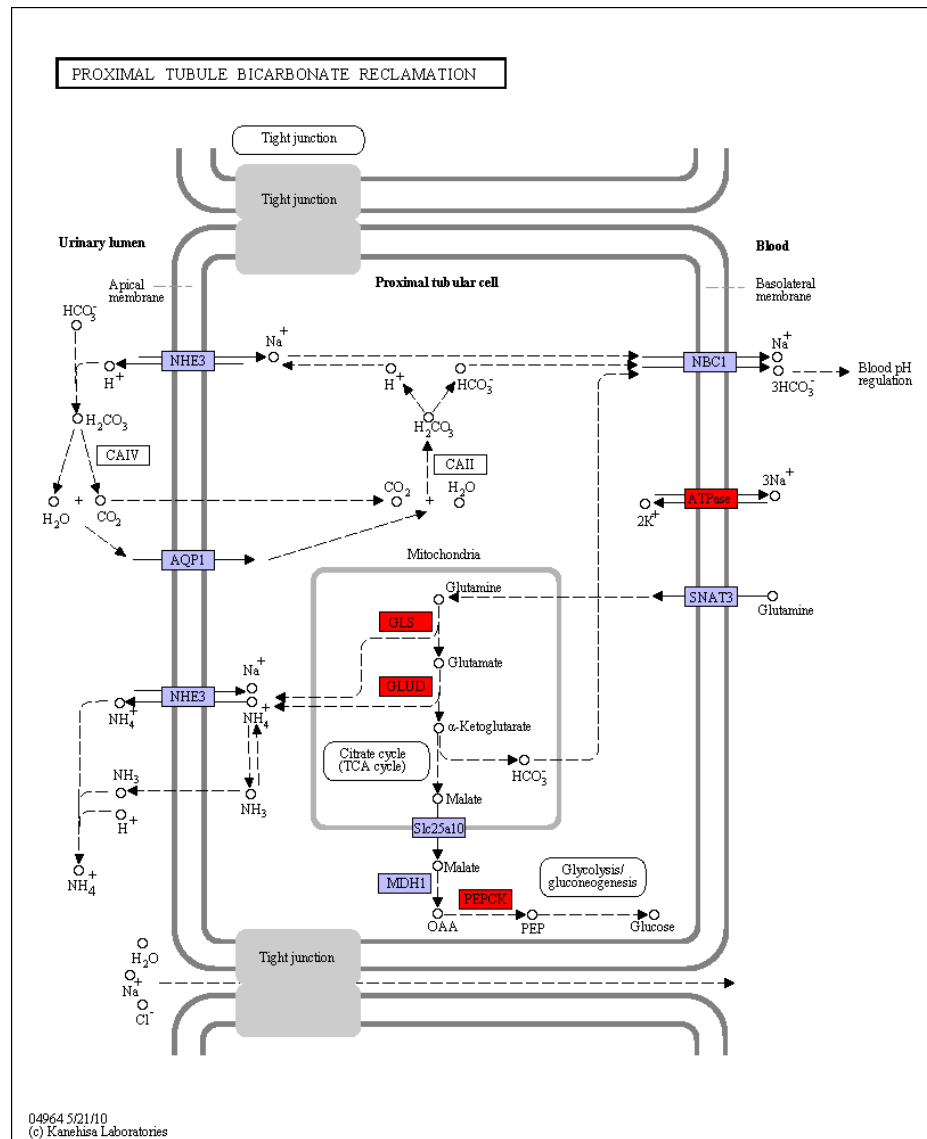
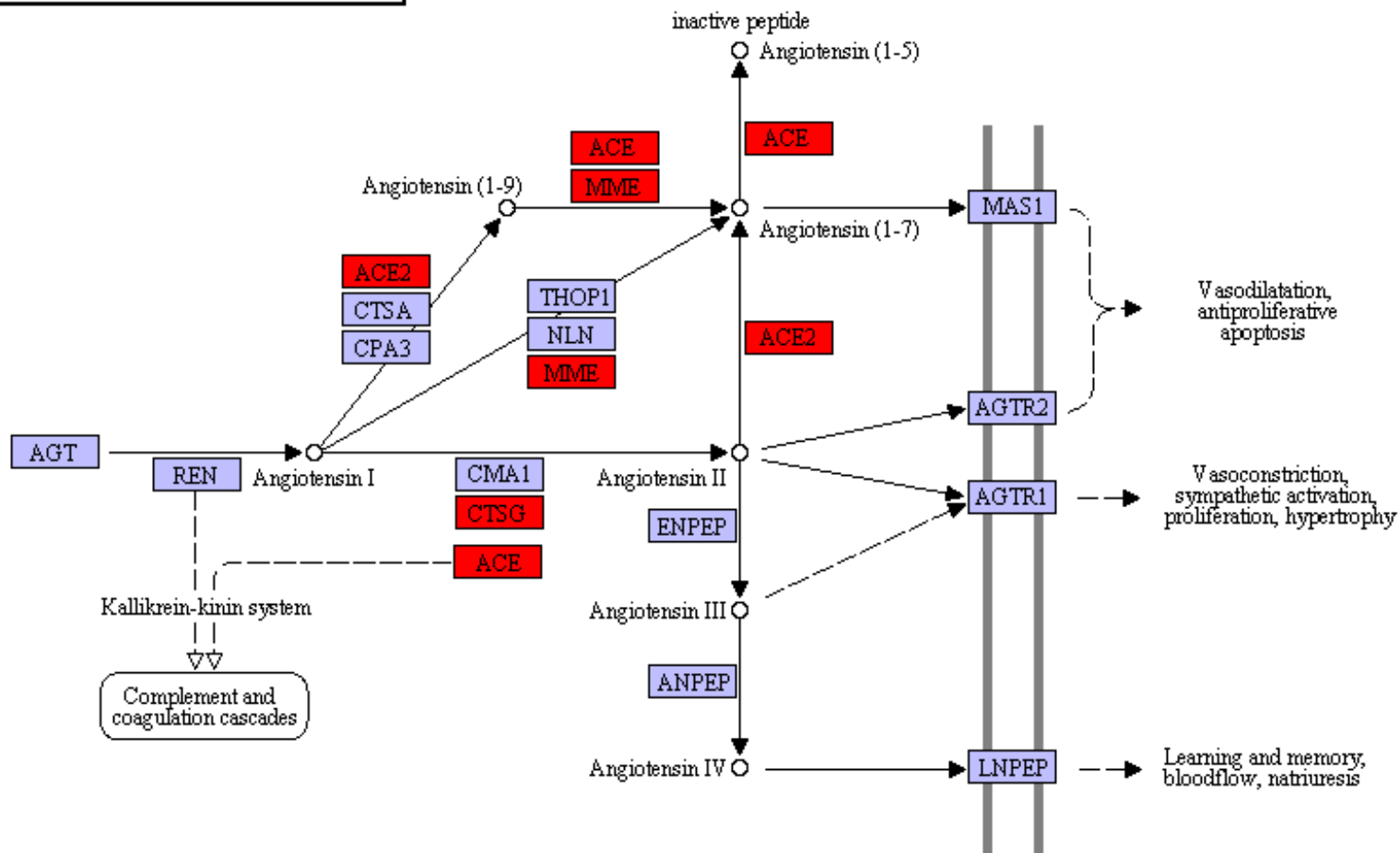

Figure 190: ko04964 Proximal tubule bicarbonate reclamation

RENIN - ANGIOTENSIN SYSTEM



04614 1/15/10  
 (c) Kanehisa Laboratories

Figure 191: ko04614 Renin-angiotensin system



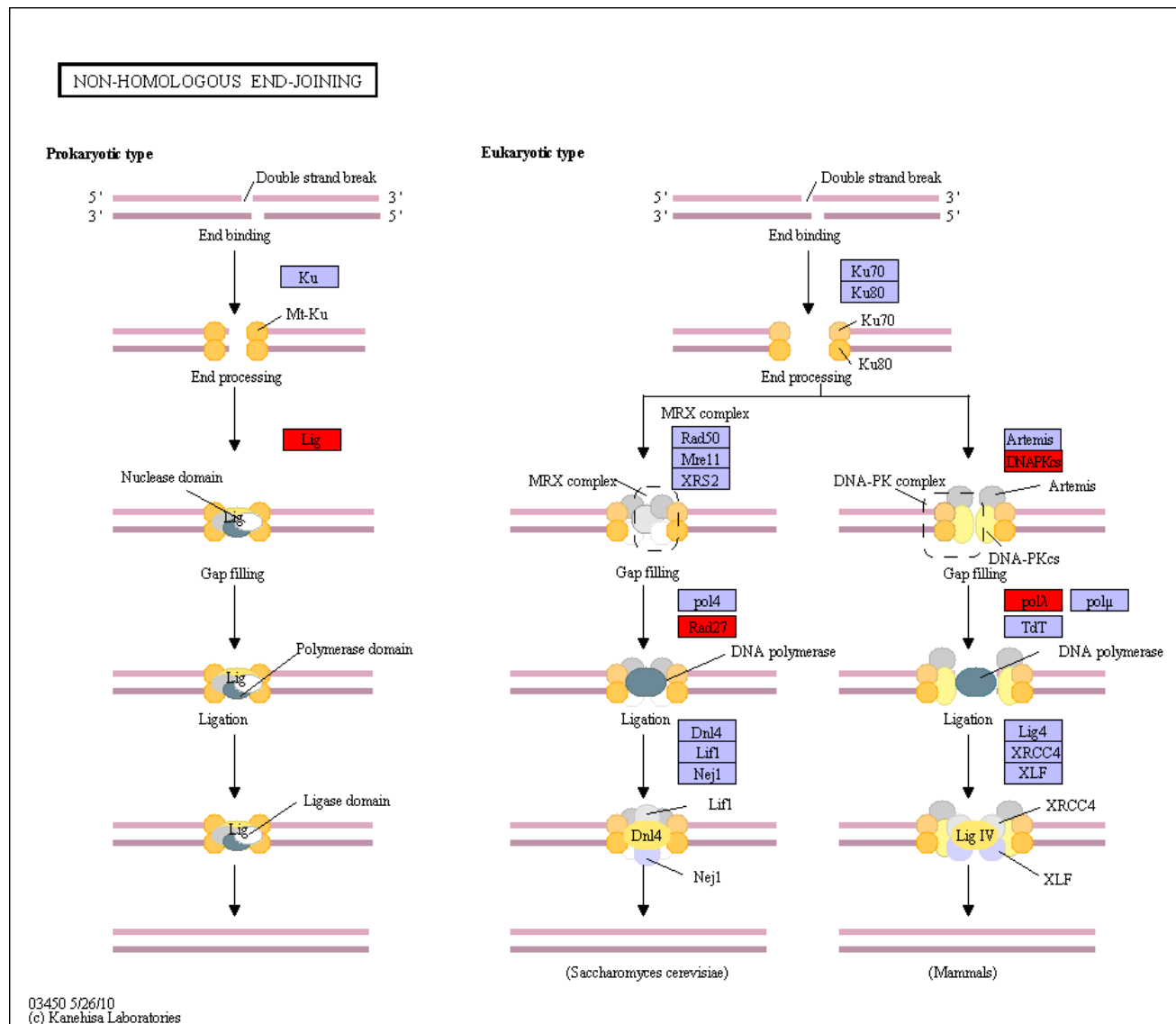

Figure 192: ko03450 Non-homologous end-joining

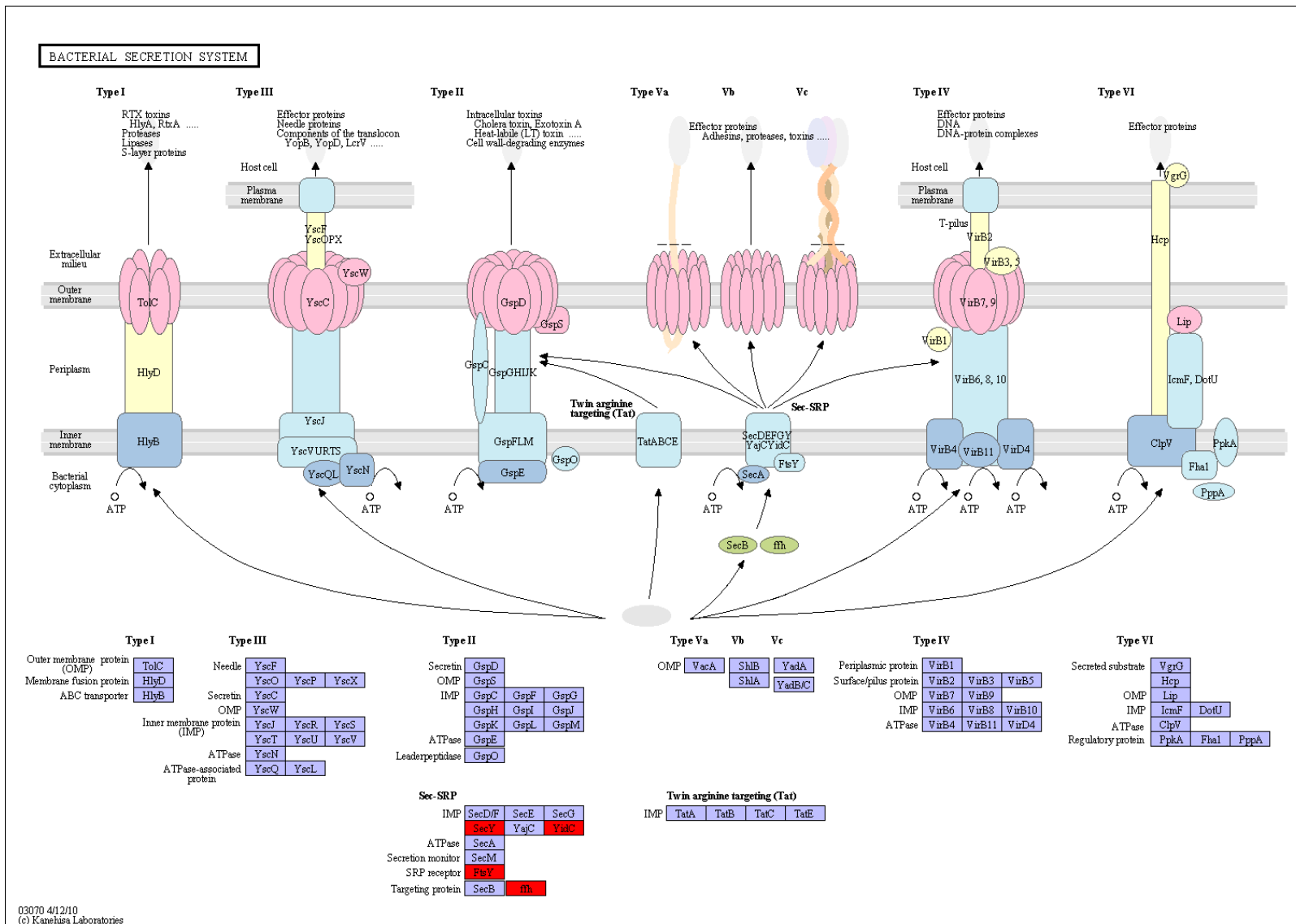

Figure 193: ko03070 Bacterial secretion system

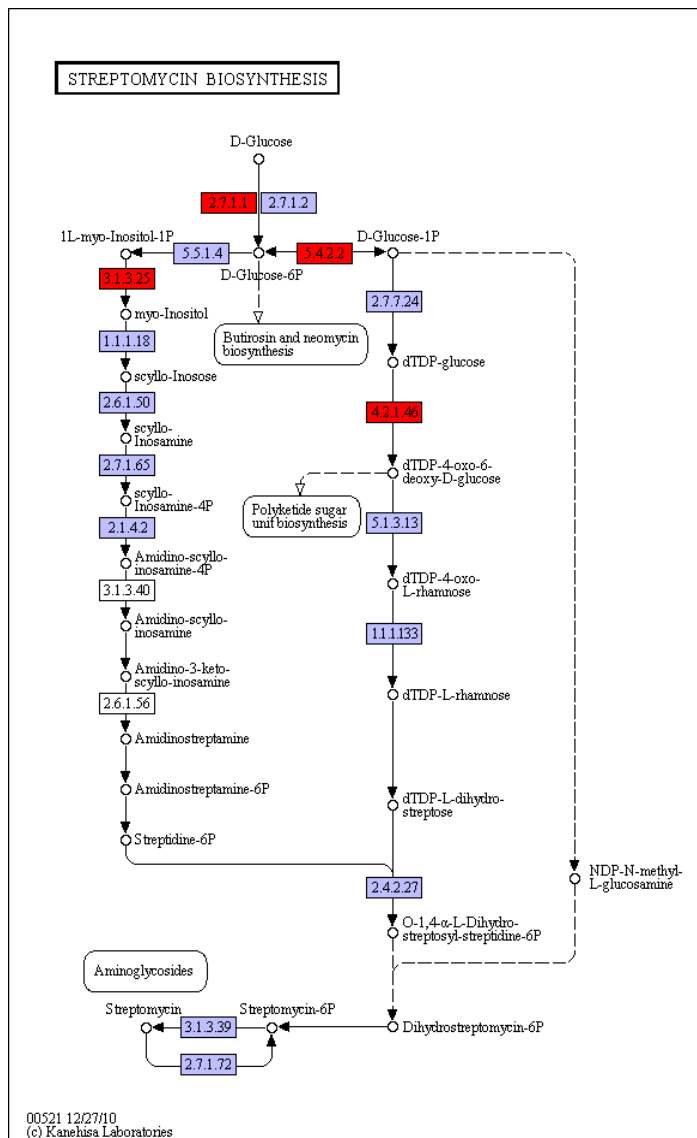

Figure 194: ko00521 Streptomycin biosynthesis

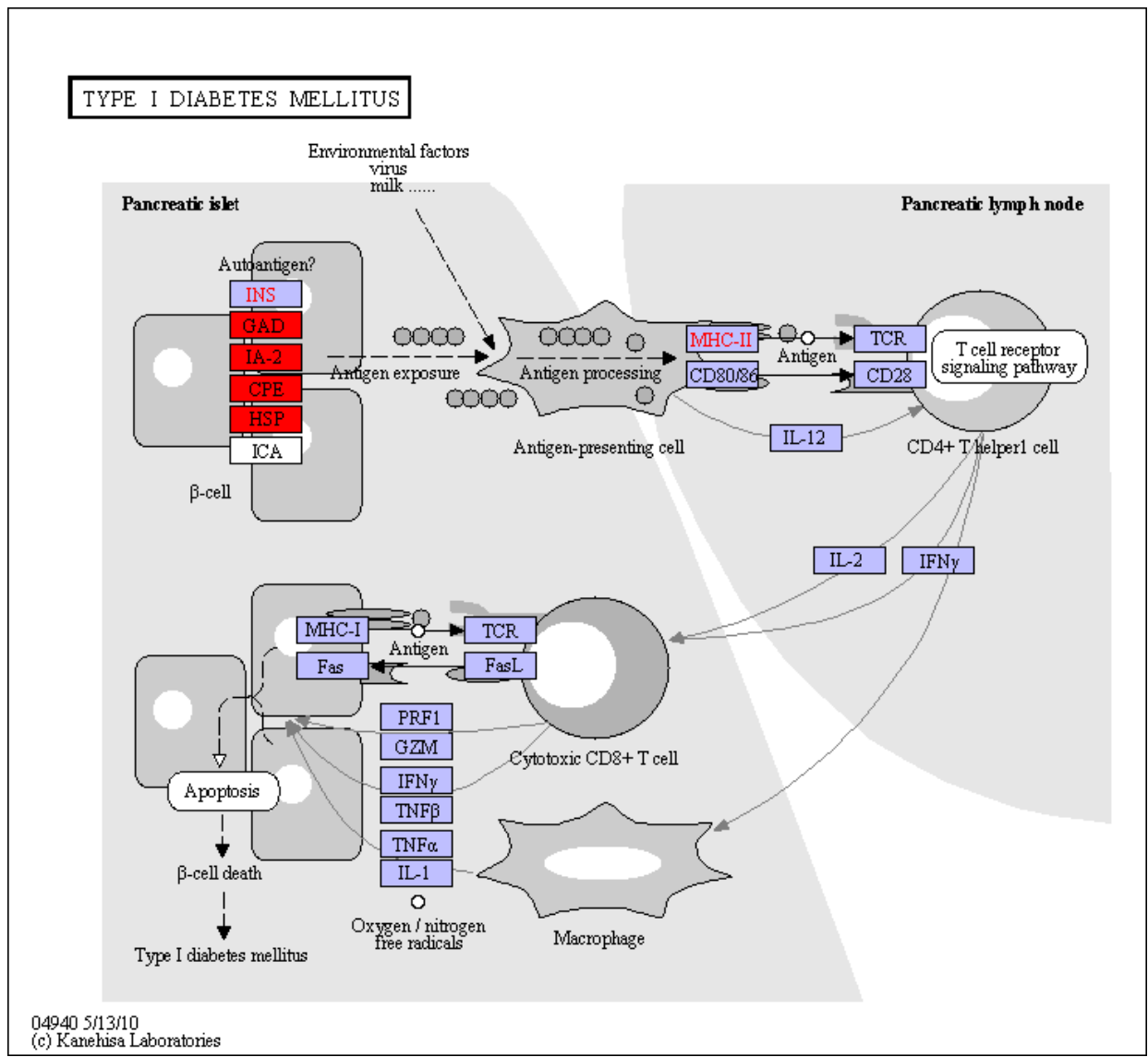

Figure 195: ko04940 Type I diabetes mellitus



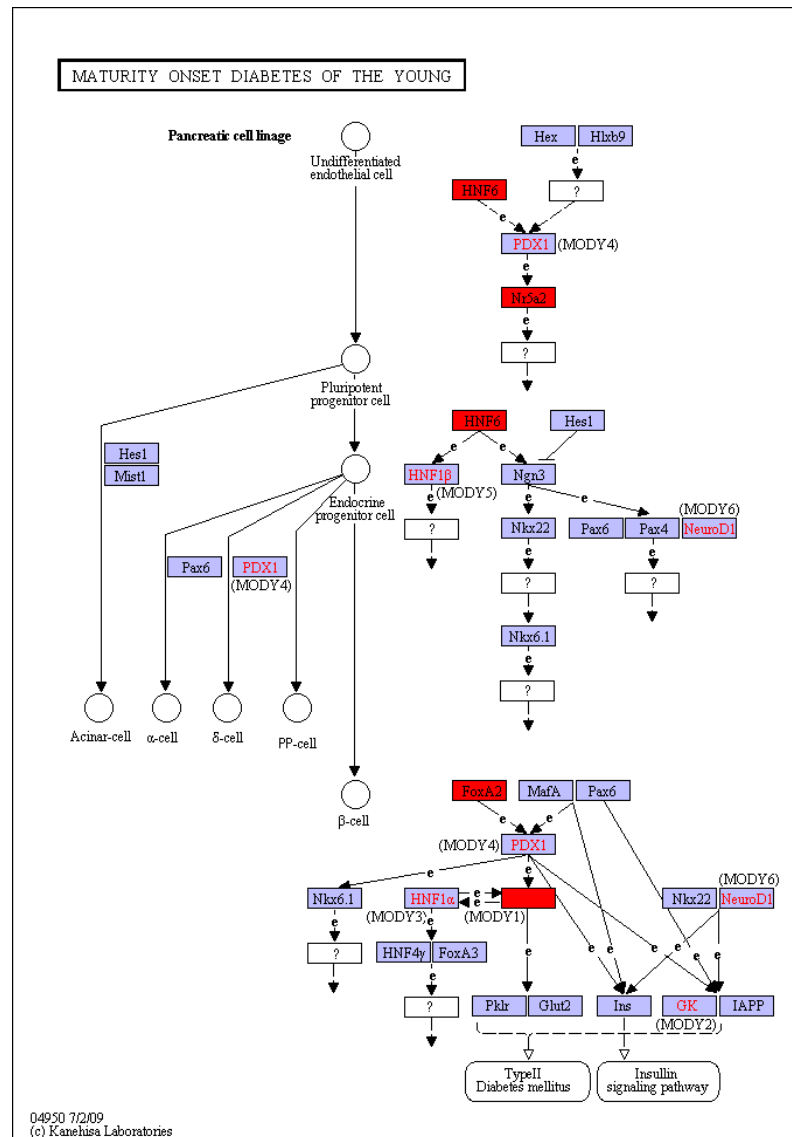

Figure 197: ko04950 Maturity onset diabetes of the young

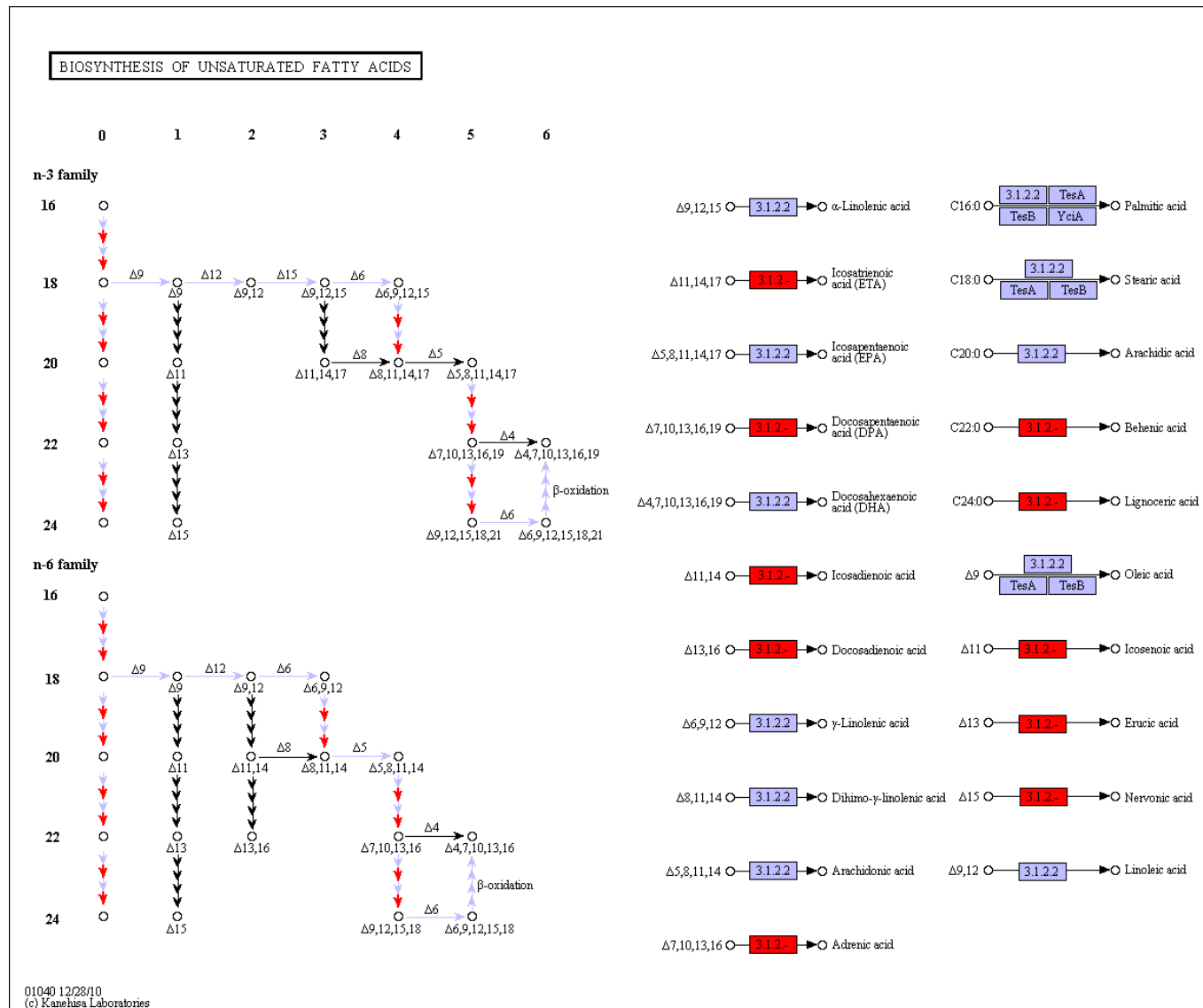

Figure 198: ko01040 Biosynthesis of unsaturated fatty acids

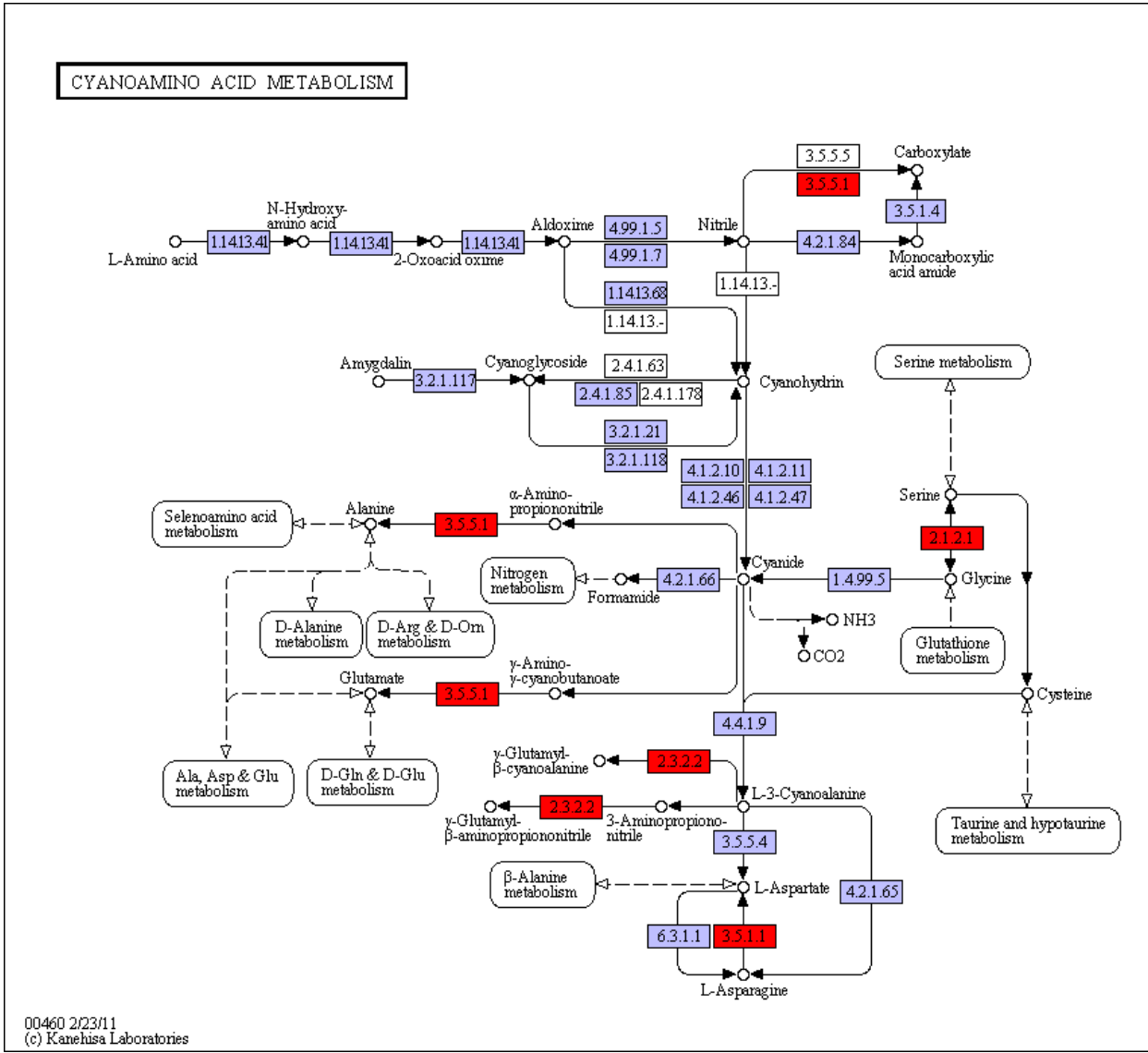

Figure 199: ko00460 Cyanoamino acid metabolism





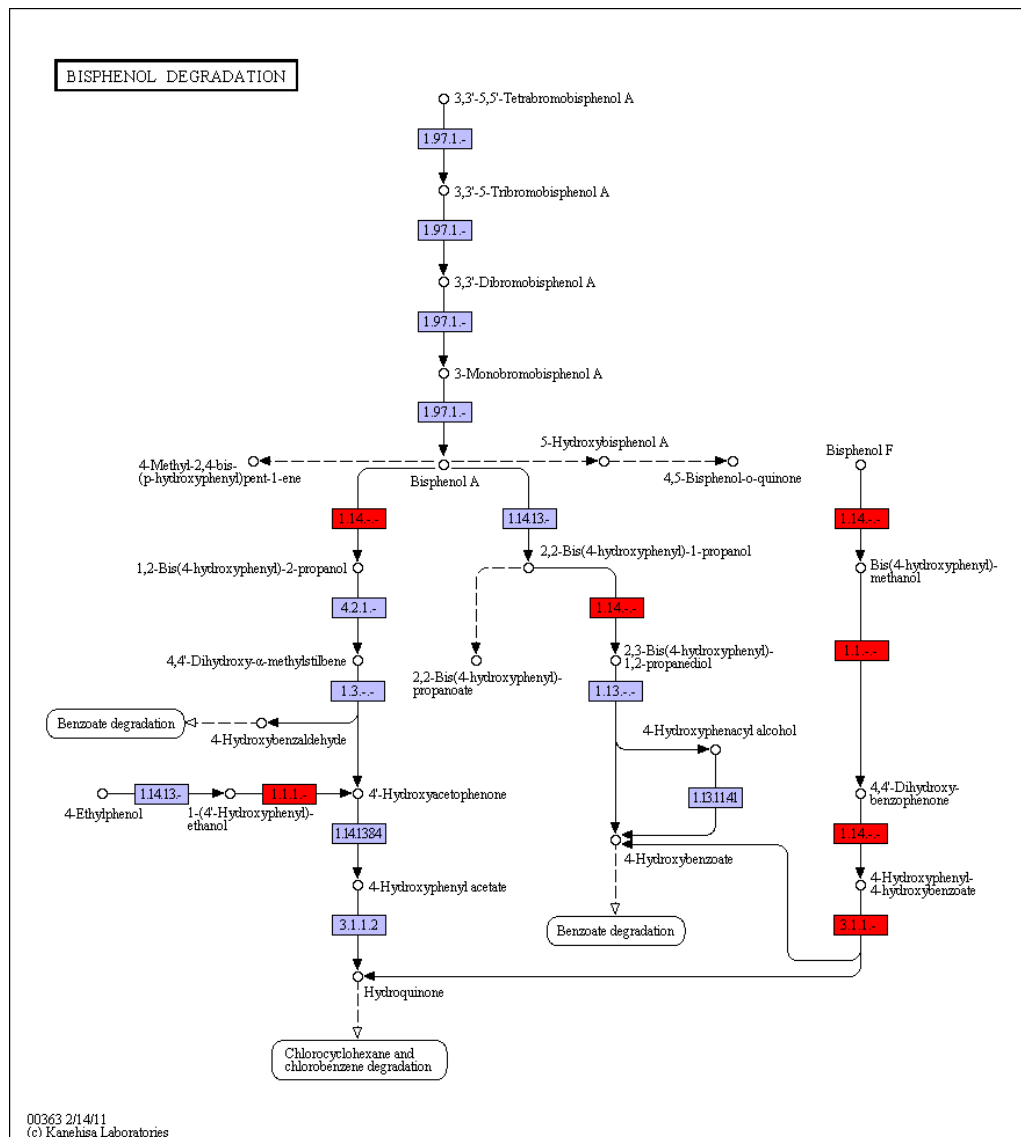

Figure 201: ko00363 Bisphenol degradation







**OTHER GLYCAN DEGRADATION**

**N-glycan**

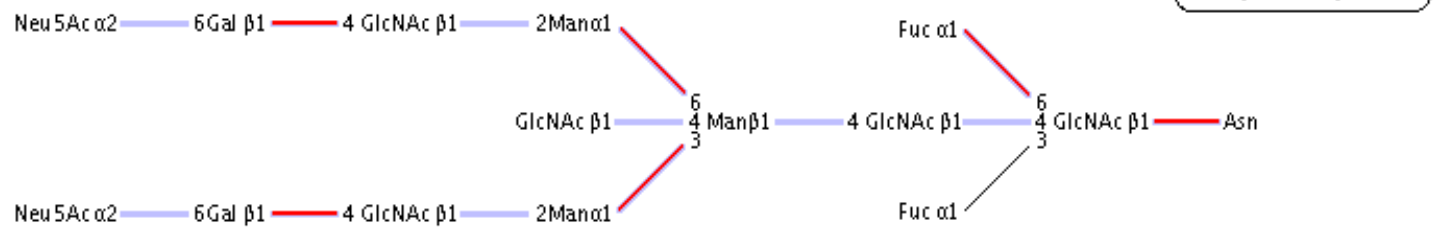

**Ganglioside**

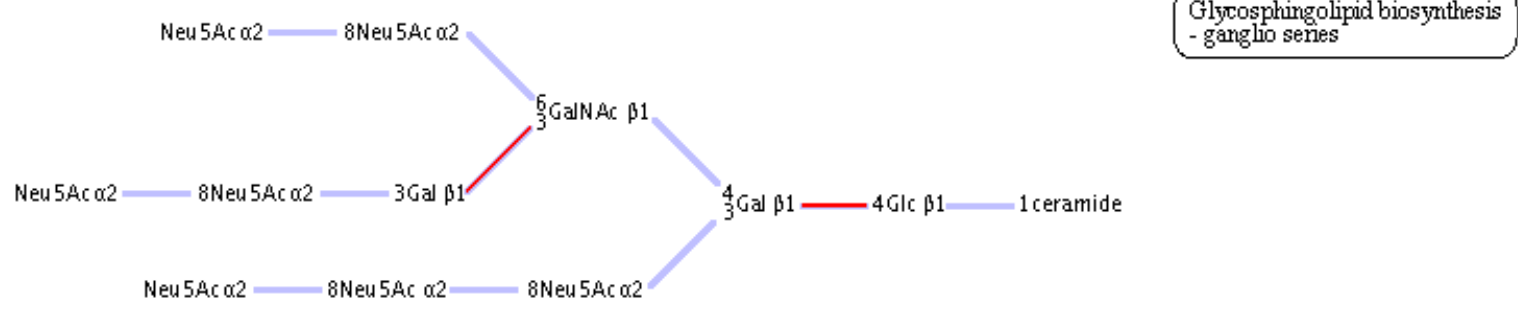

00511 2/1/11  
 (c) Kanehisa Laboratories

Figure 205: ko00511 Other glycan degradation

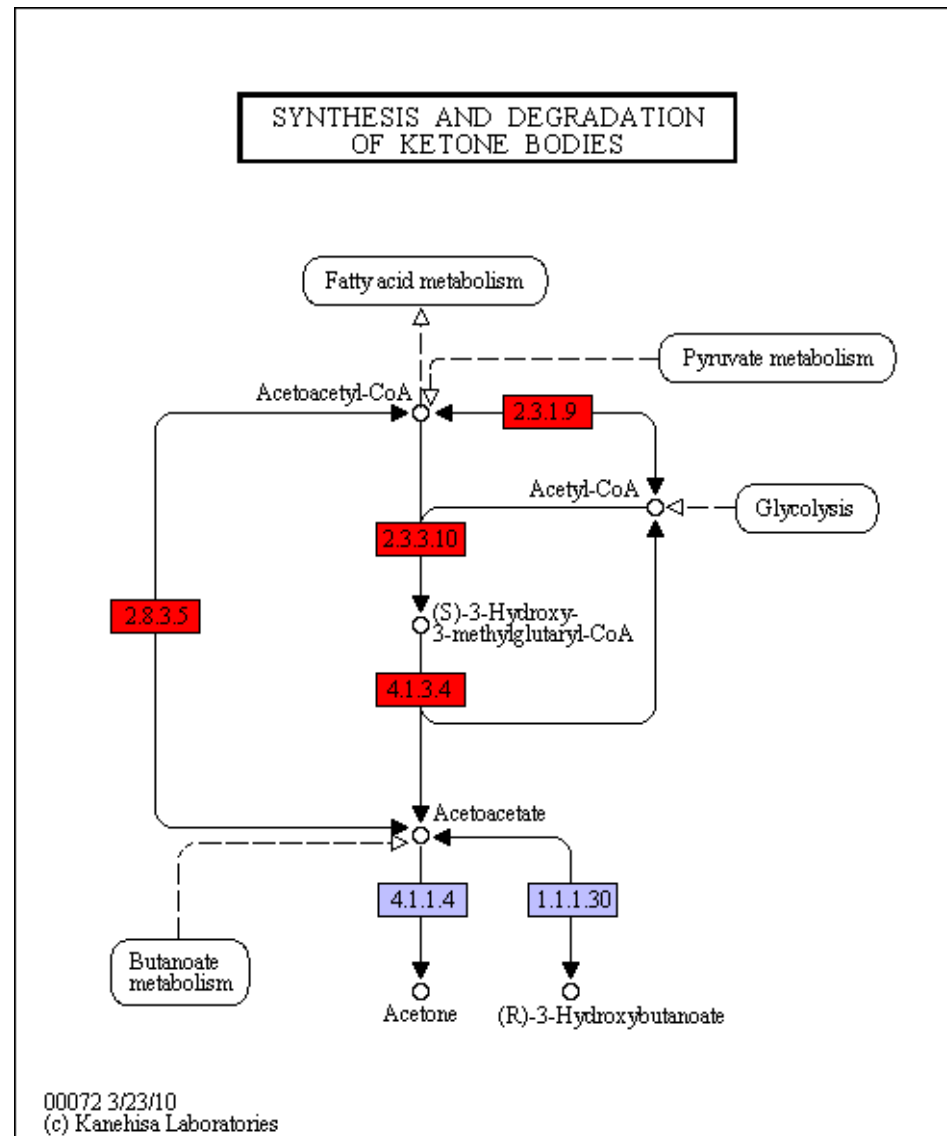
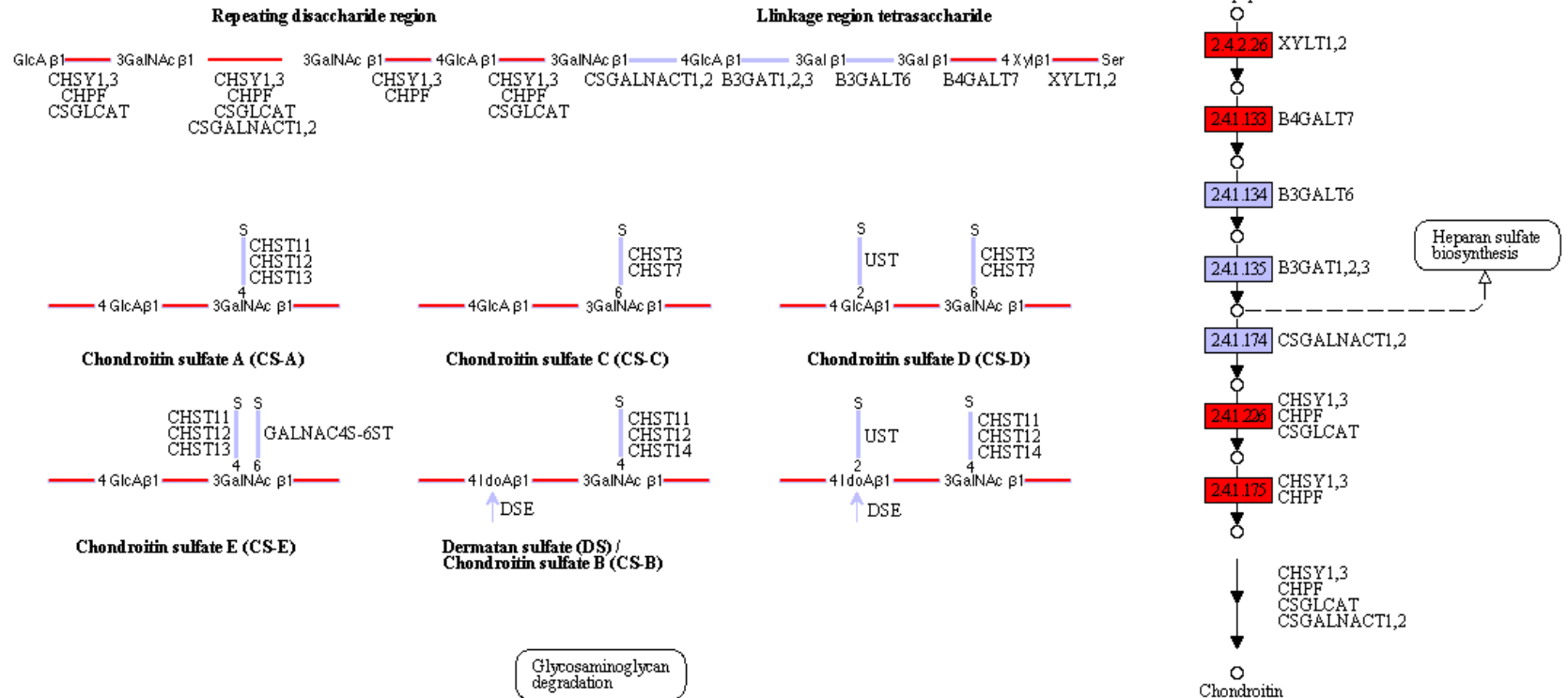

Figure 206: ko00072 Synthesis and degradation of ketone bodies





GLYCOSAMINOGLYCAN BIOSYNTHESIS - CHONDROITIN SULFATE



00532 3/8/10  
 (c) Kanehisa Laboratories

Figure 208: ko00532 Glycosaminoglycan biosynthesis - chondroitin sulfate

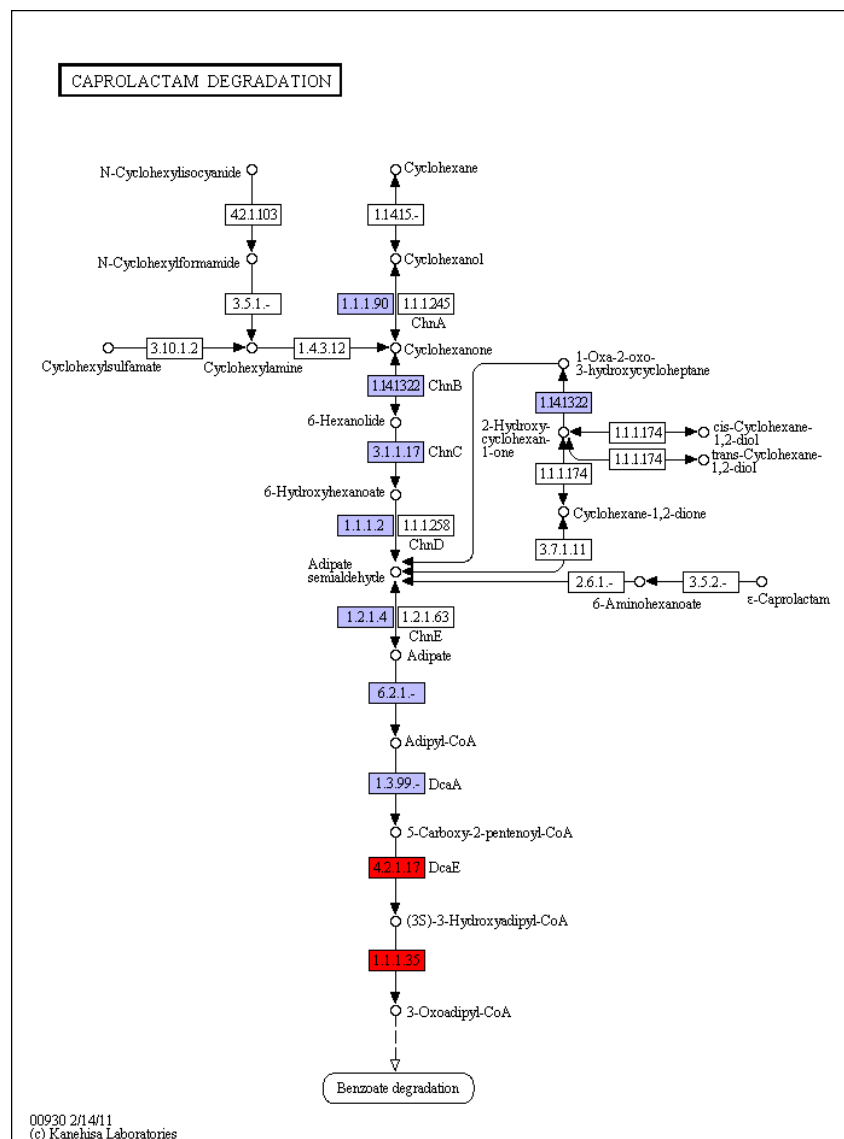

Figure 209: ko00930 Caprolactam degradation





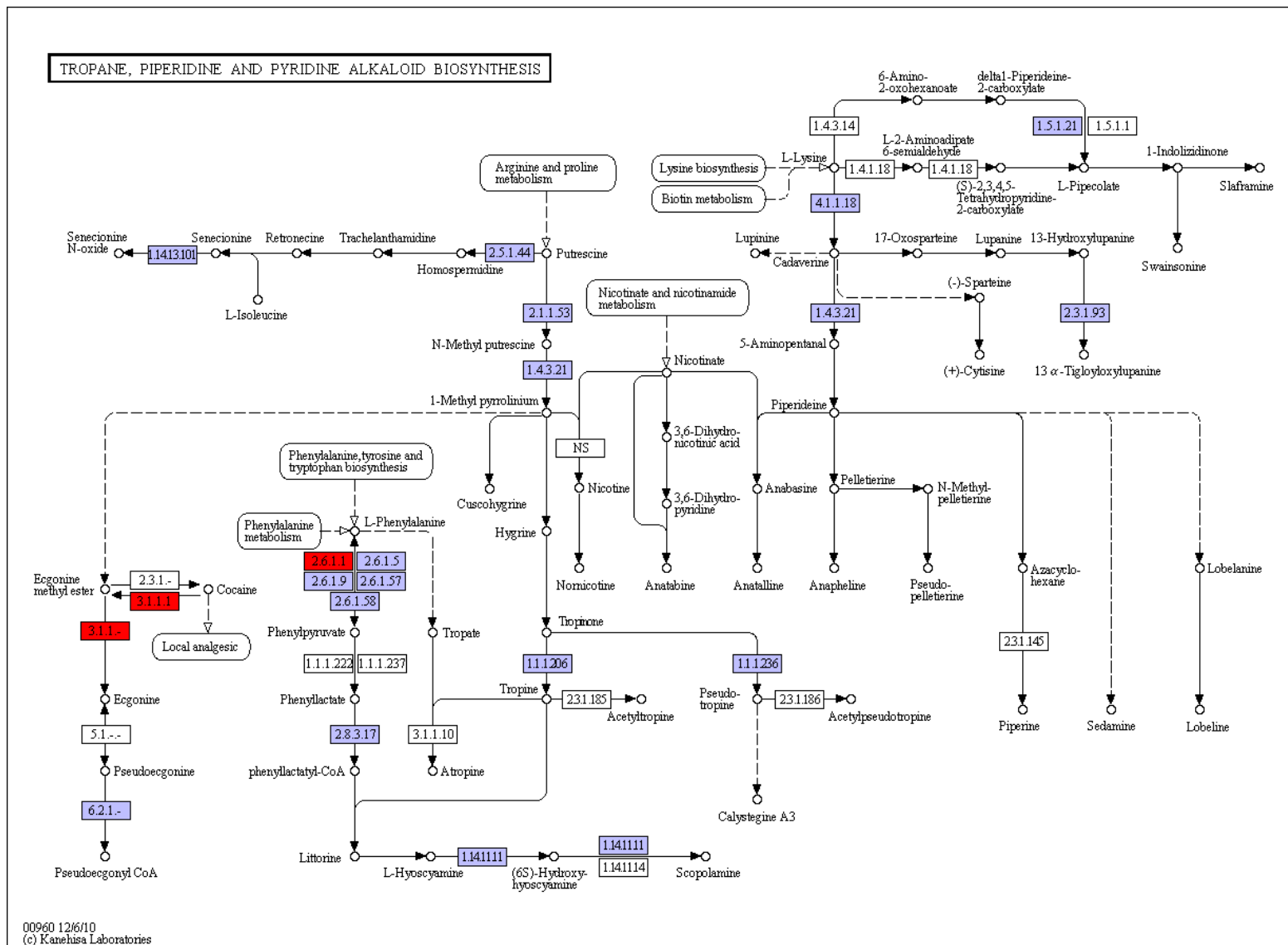
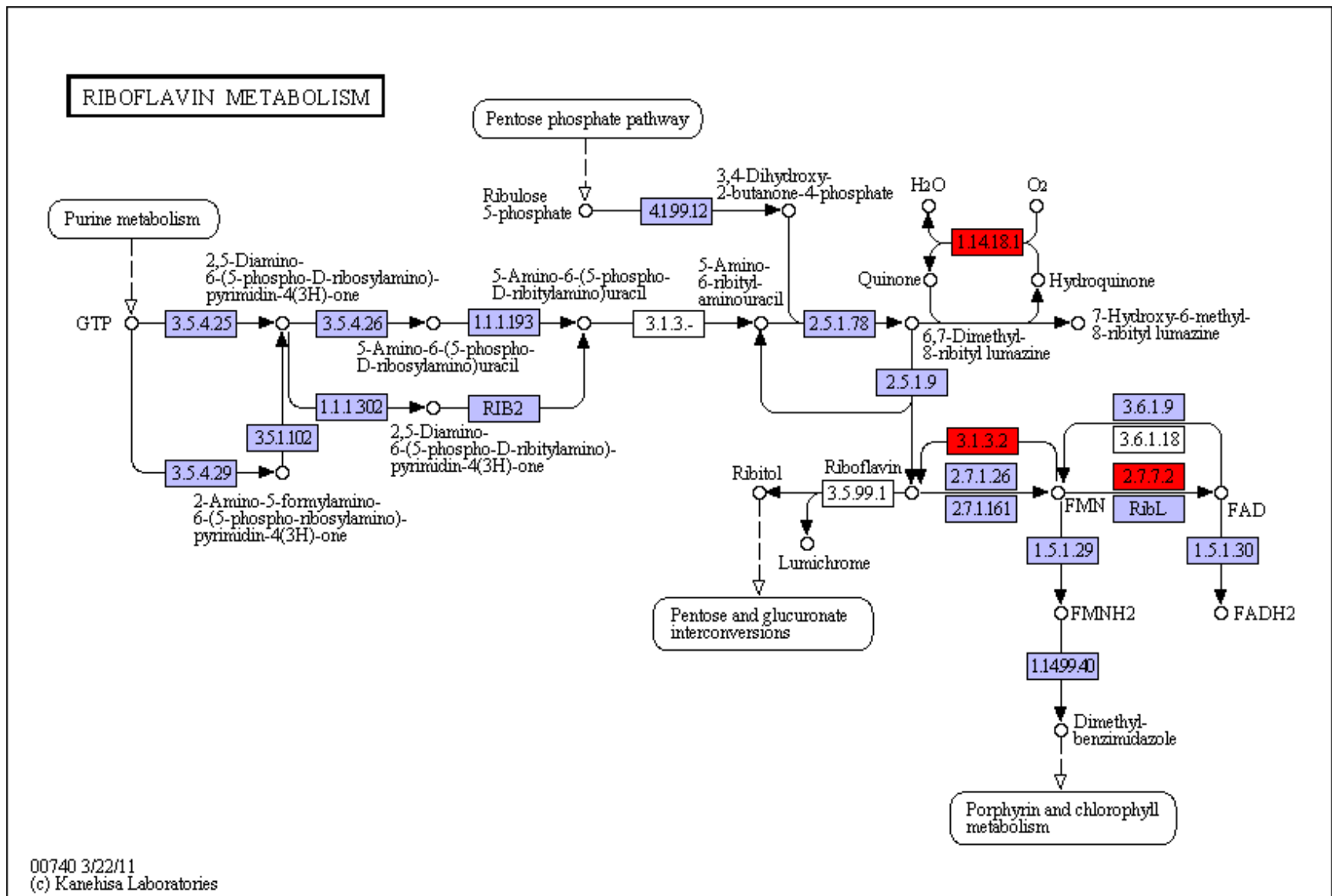

Figure 212: ko00960 Tropane, piperidine and pyridine alkaloid biosynthesis



00740 3/22/11  
 (c) Kanehisa Laboratories

Figure 213: ko00740 Riboflavin metabolism

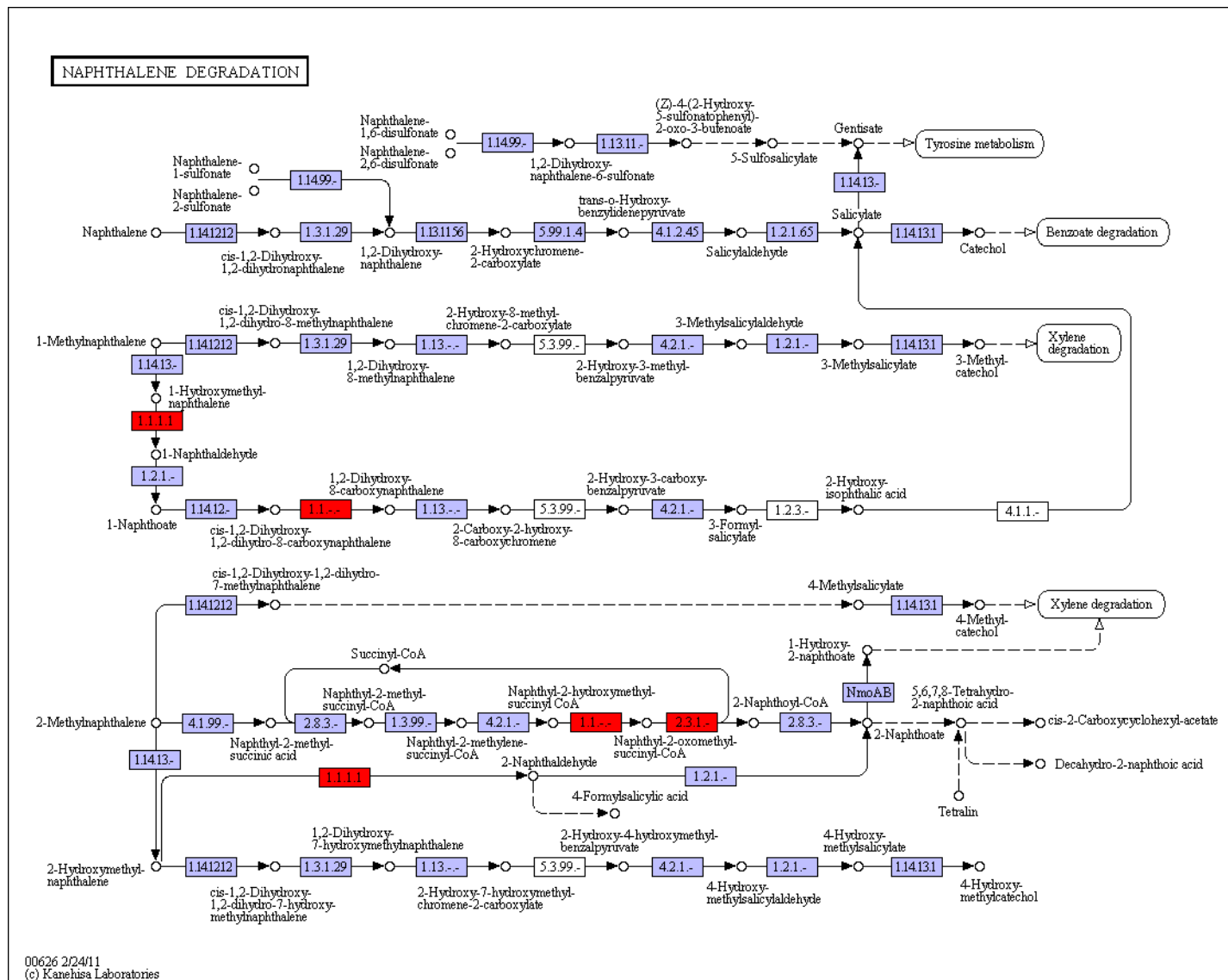

Figure 214: ko00626 Naphthalene degradation







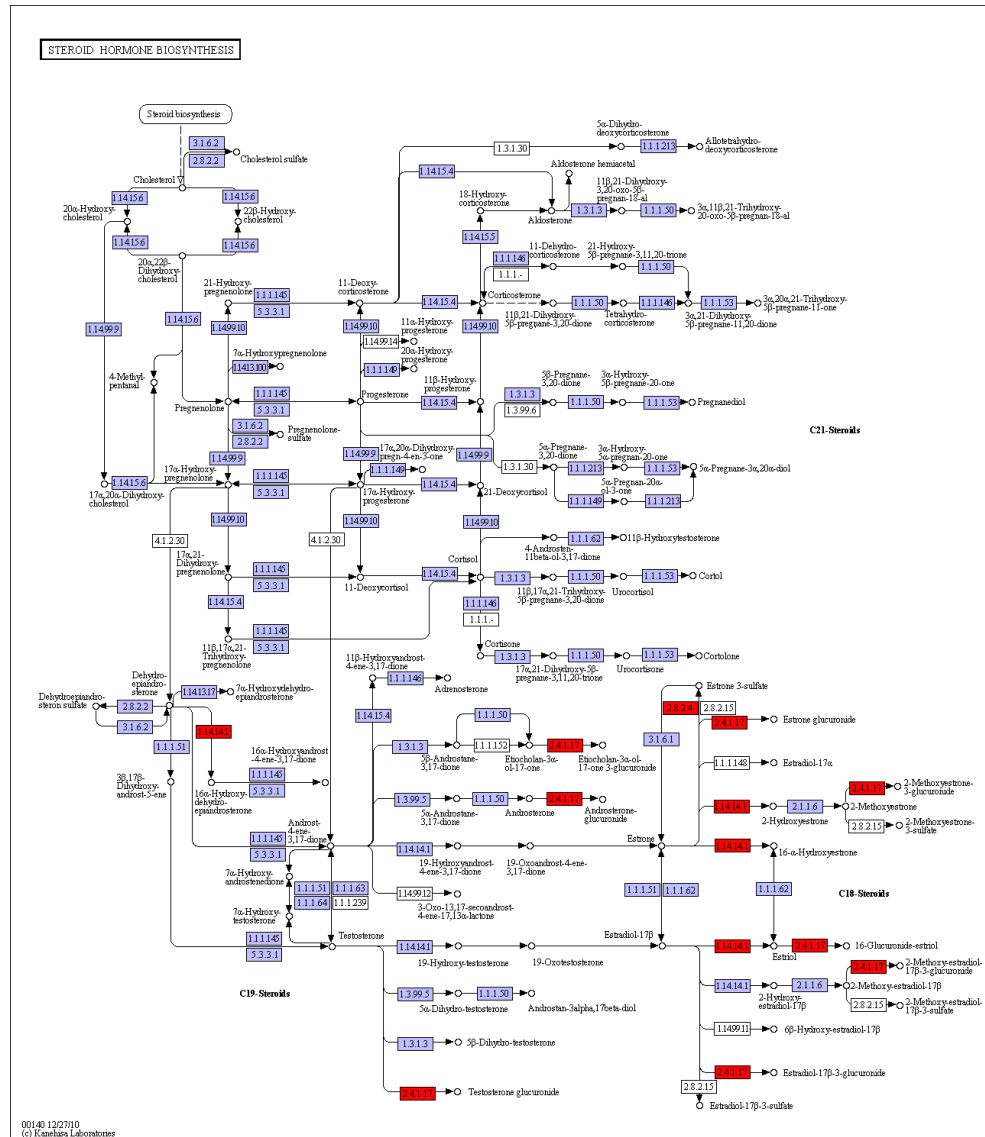

Figure 217: ko00140 Steroid hormone biosynthesis

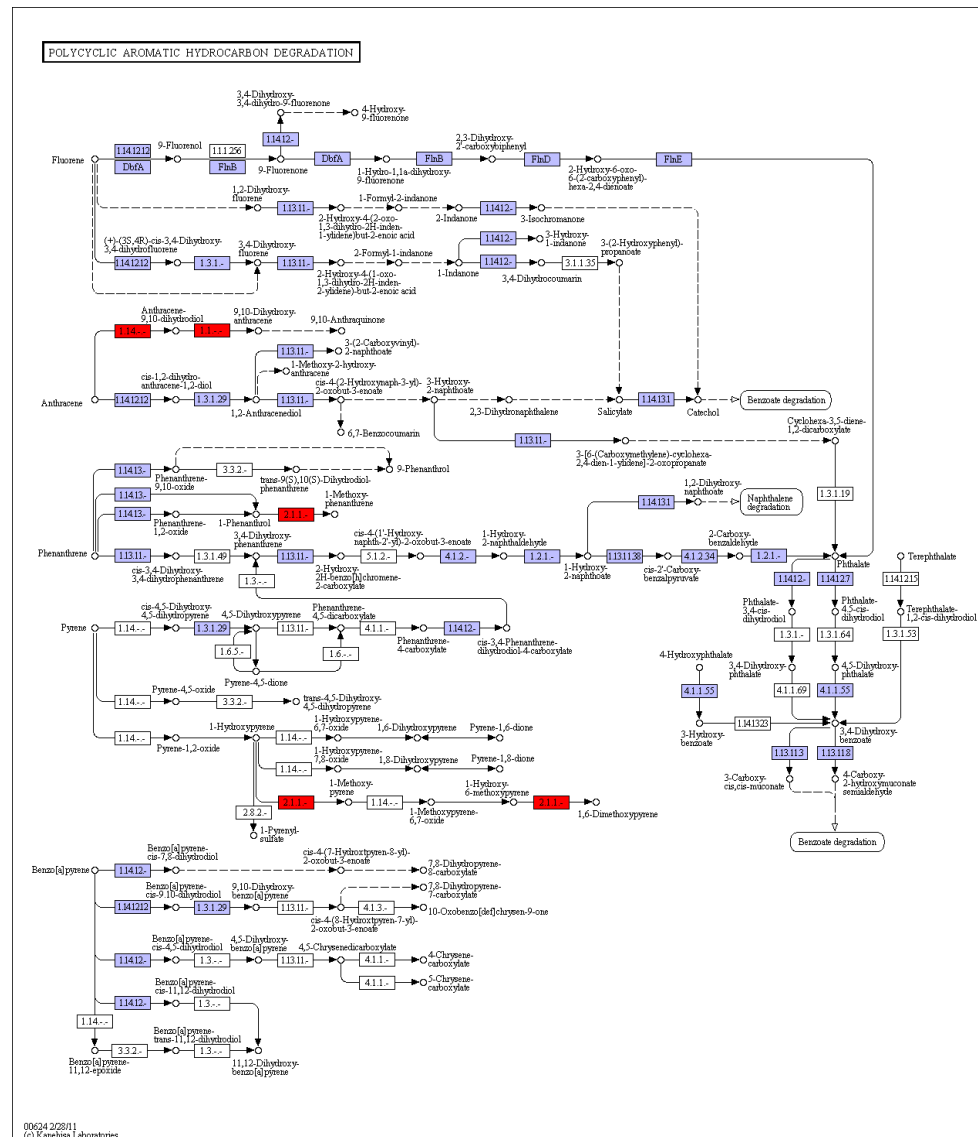

Figure 218: ko00624 Polycyclic aromatic hydrocarbon degradation

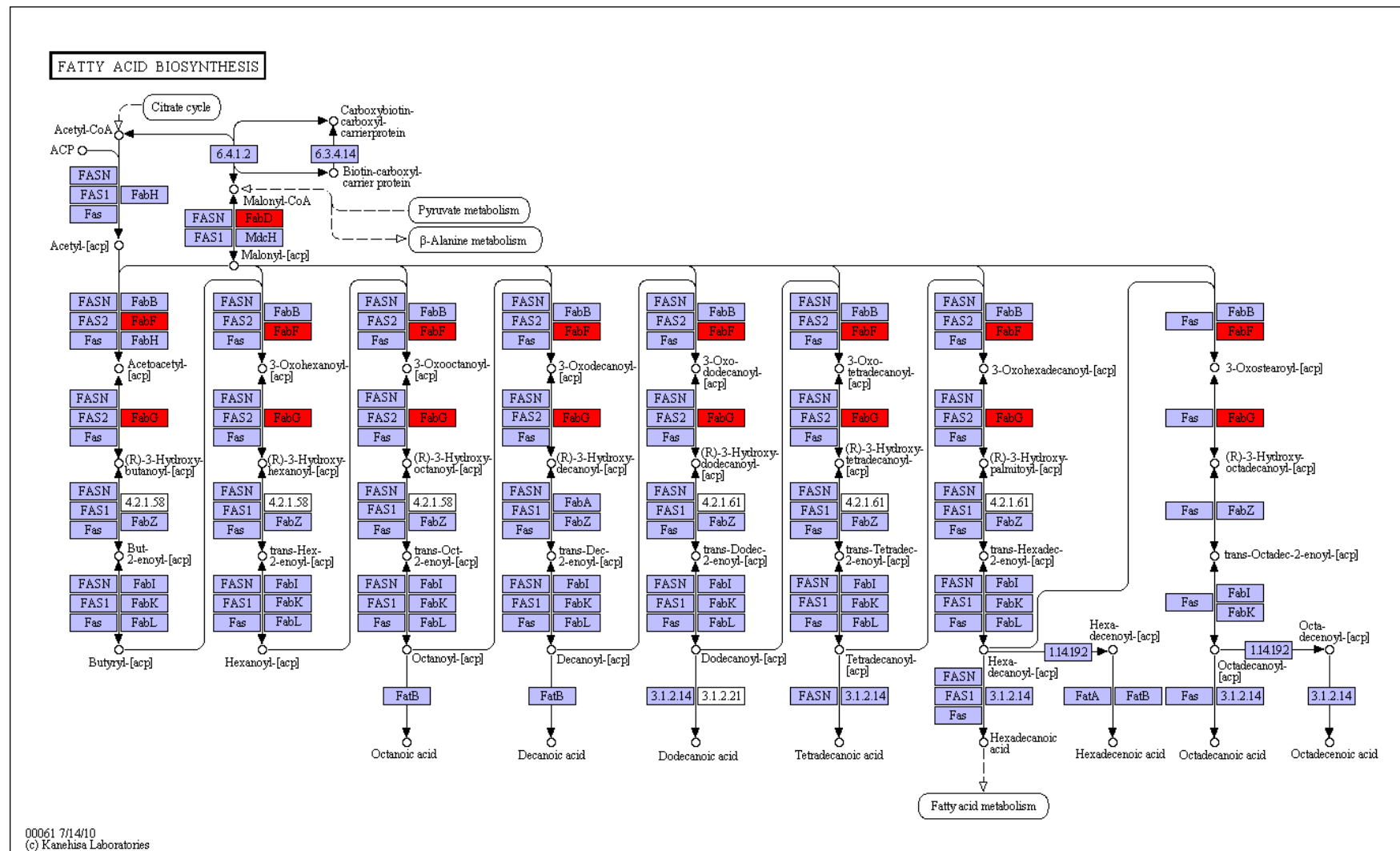

Figure 219: ko00061 Fatty acid biosynthesis

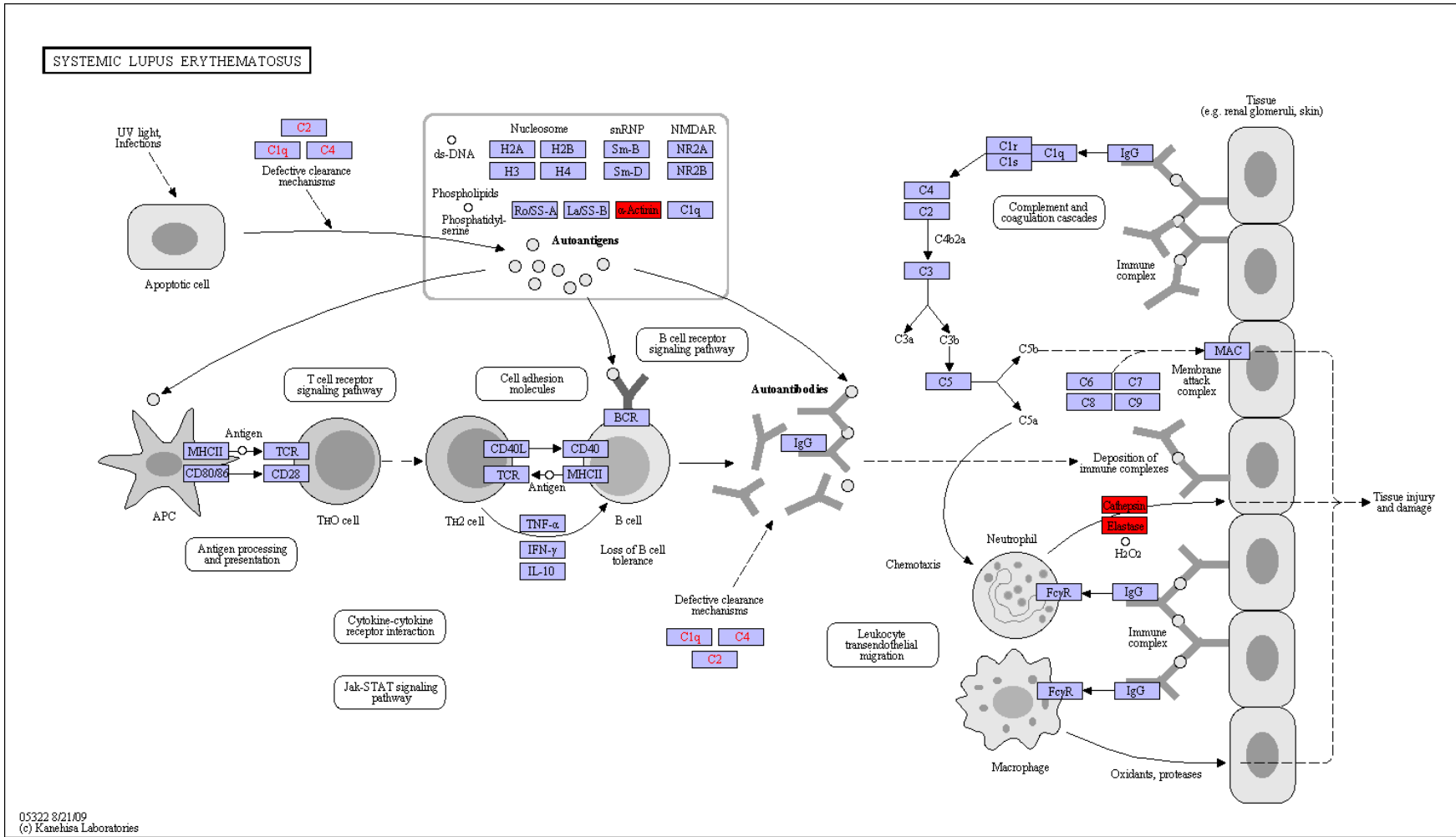

Figure 220: ko5322 Systemic lupus erythematosus

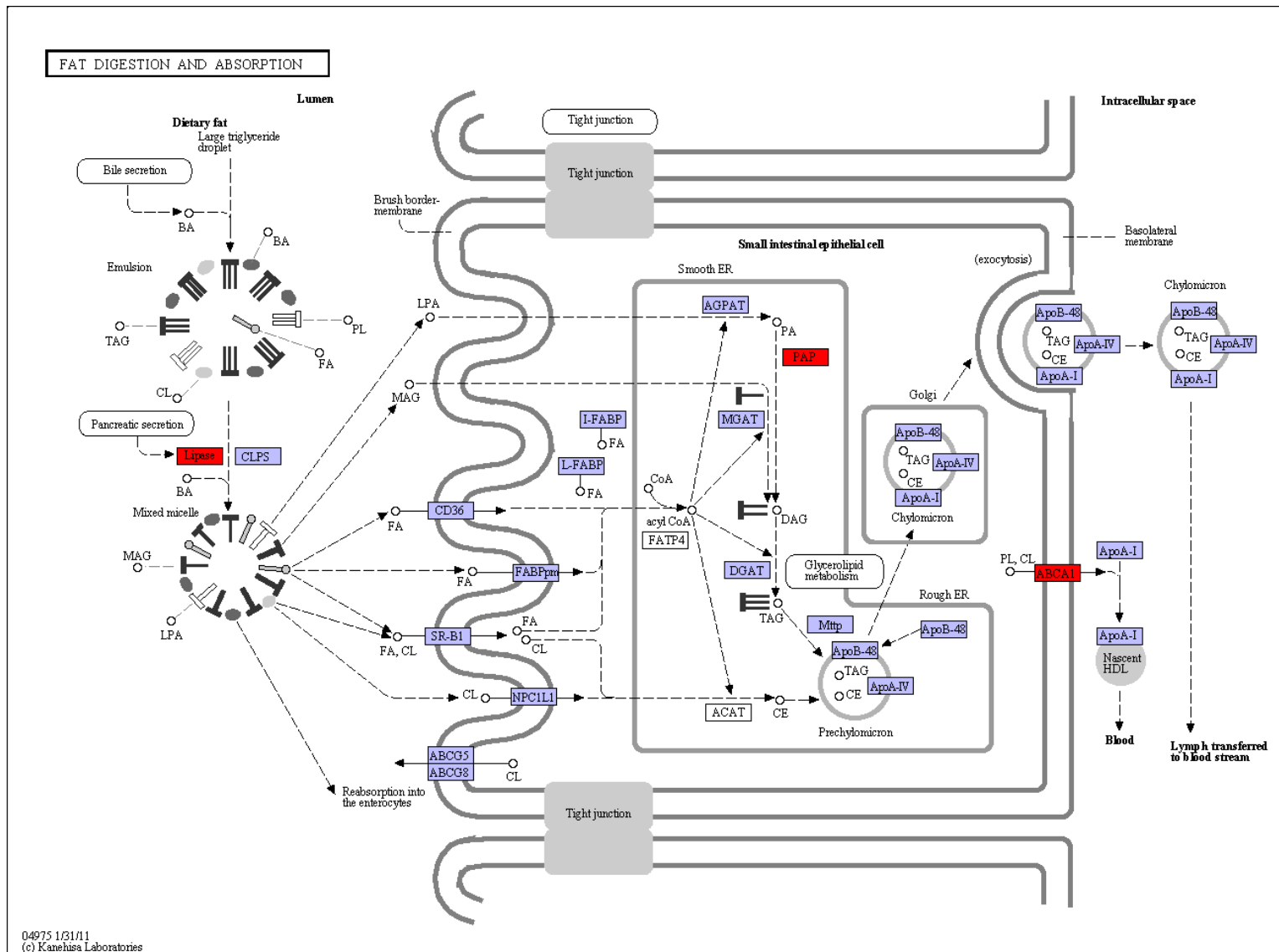

Figure 221: ko04975 Fat digestion and absorption

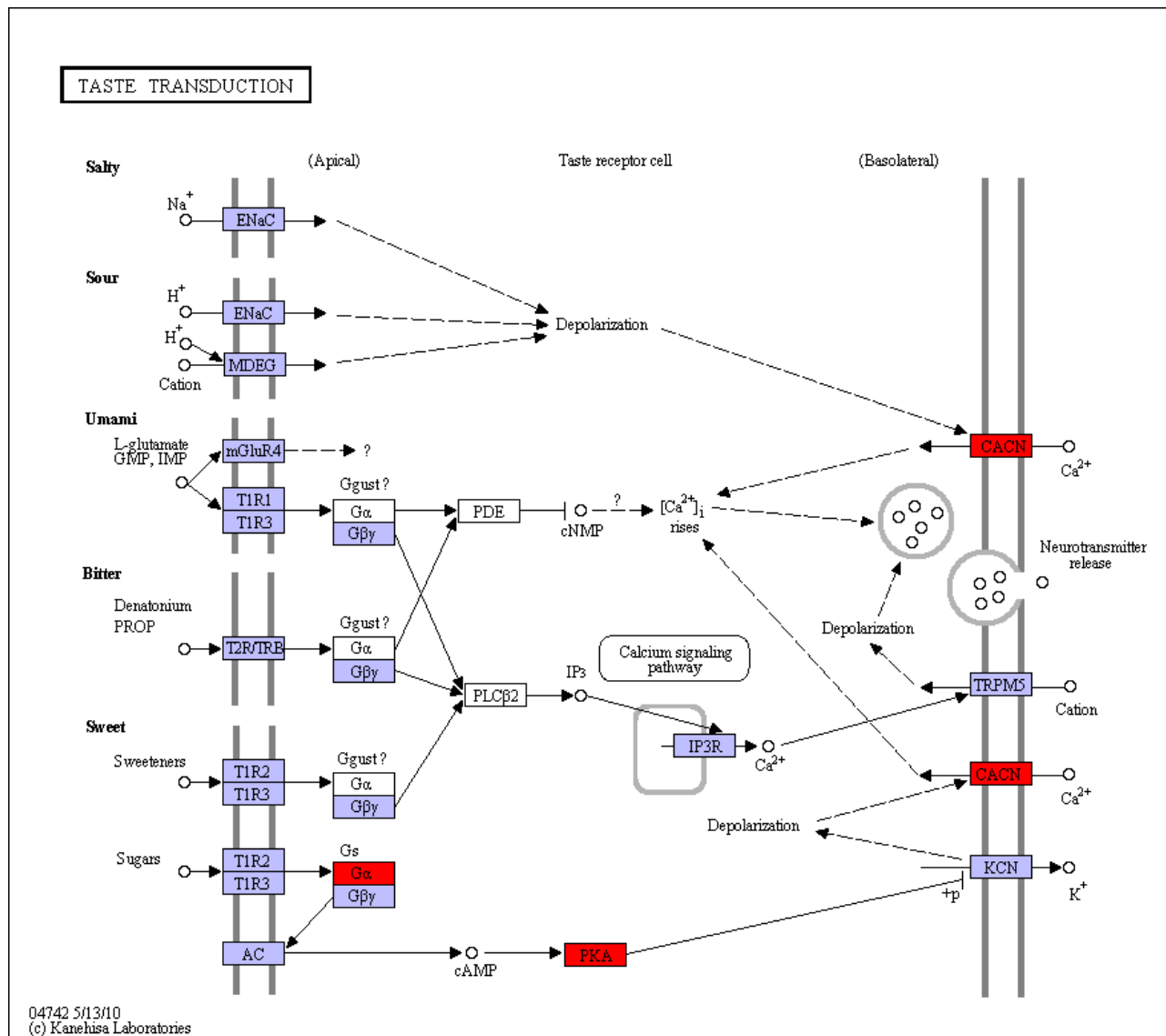

Figure 222: ko04742 Taste transduction

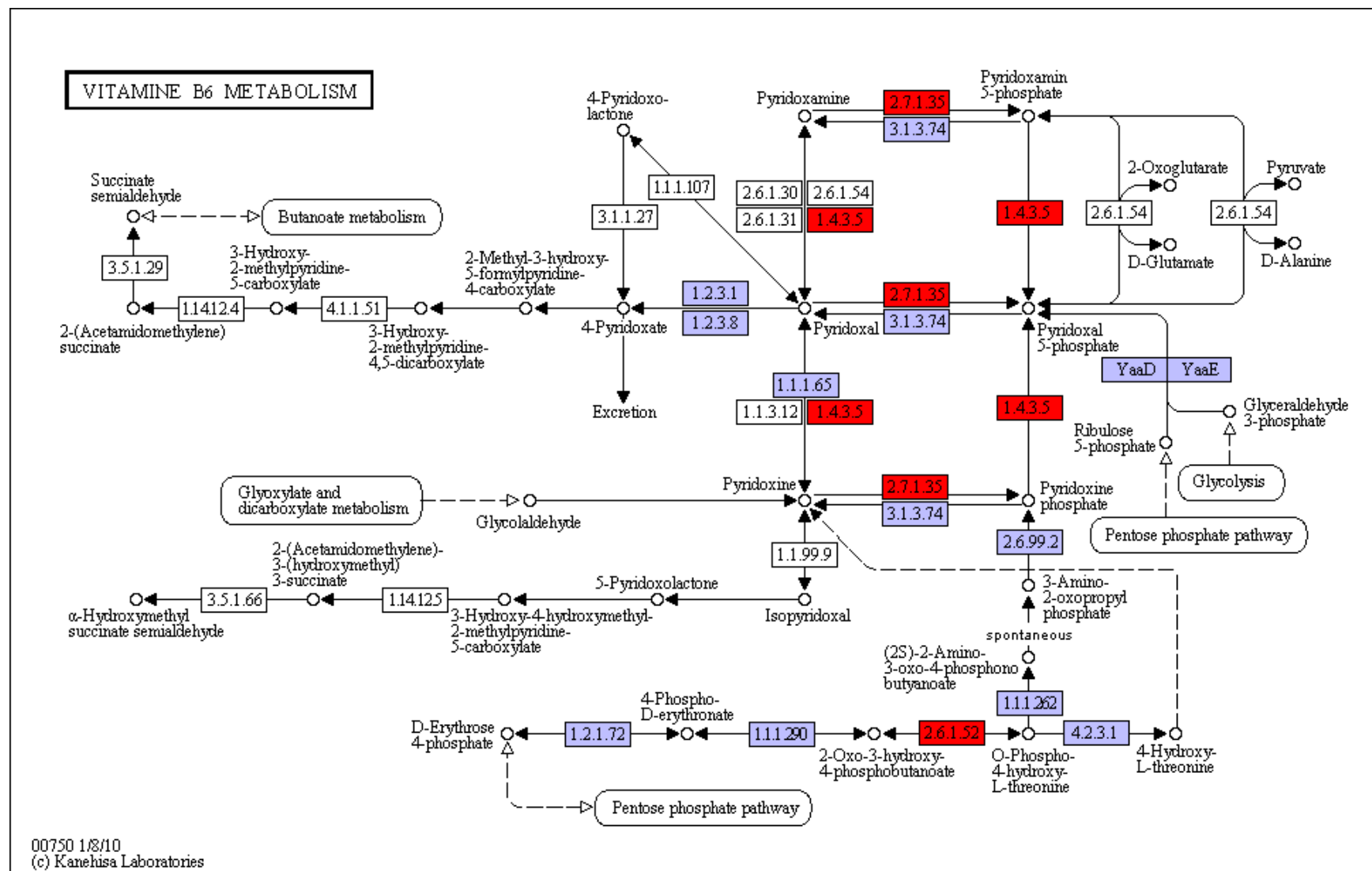

Figure 223: ko00750 Vitamin B6 metabolism



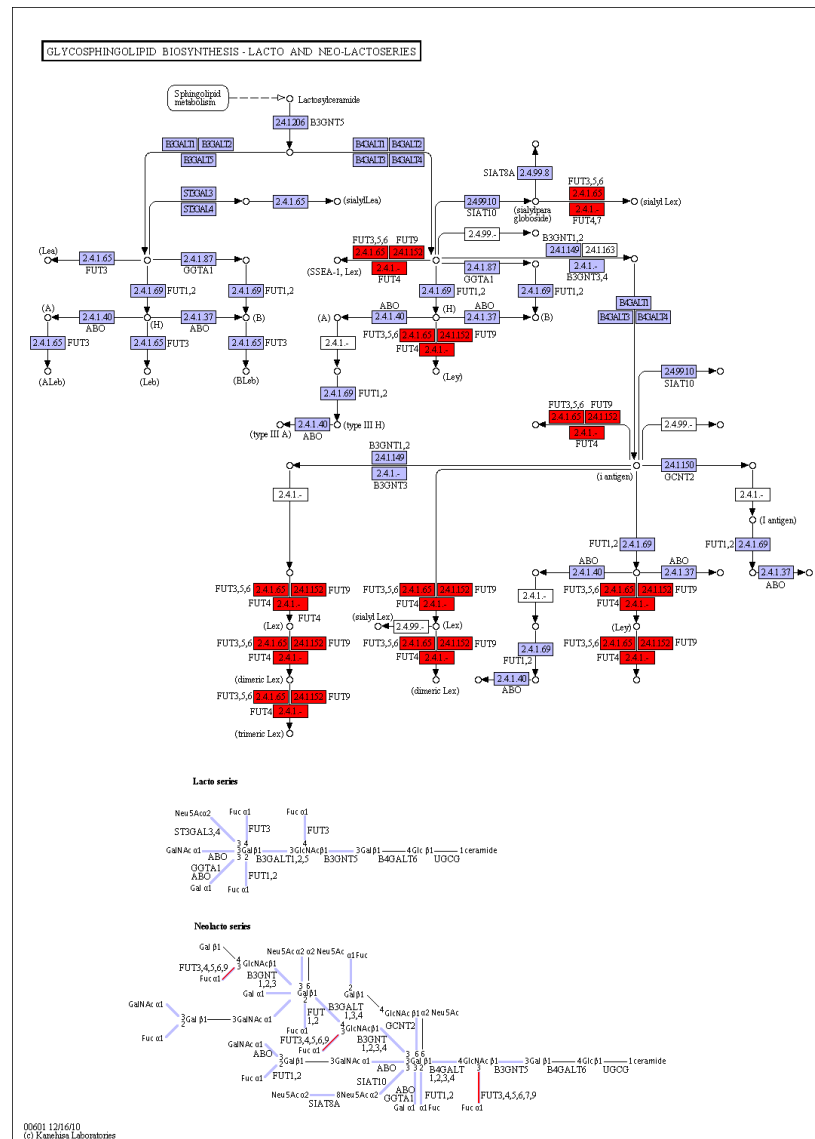

Figure 224: ko00601 Glycosphingolipid biosynthesis - lacto and neolacto series



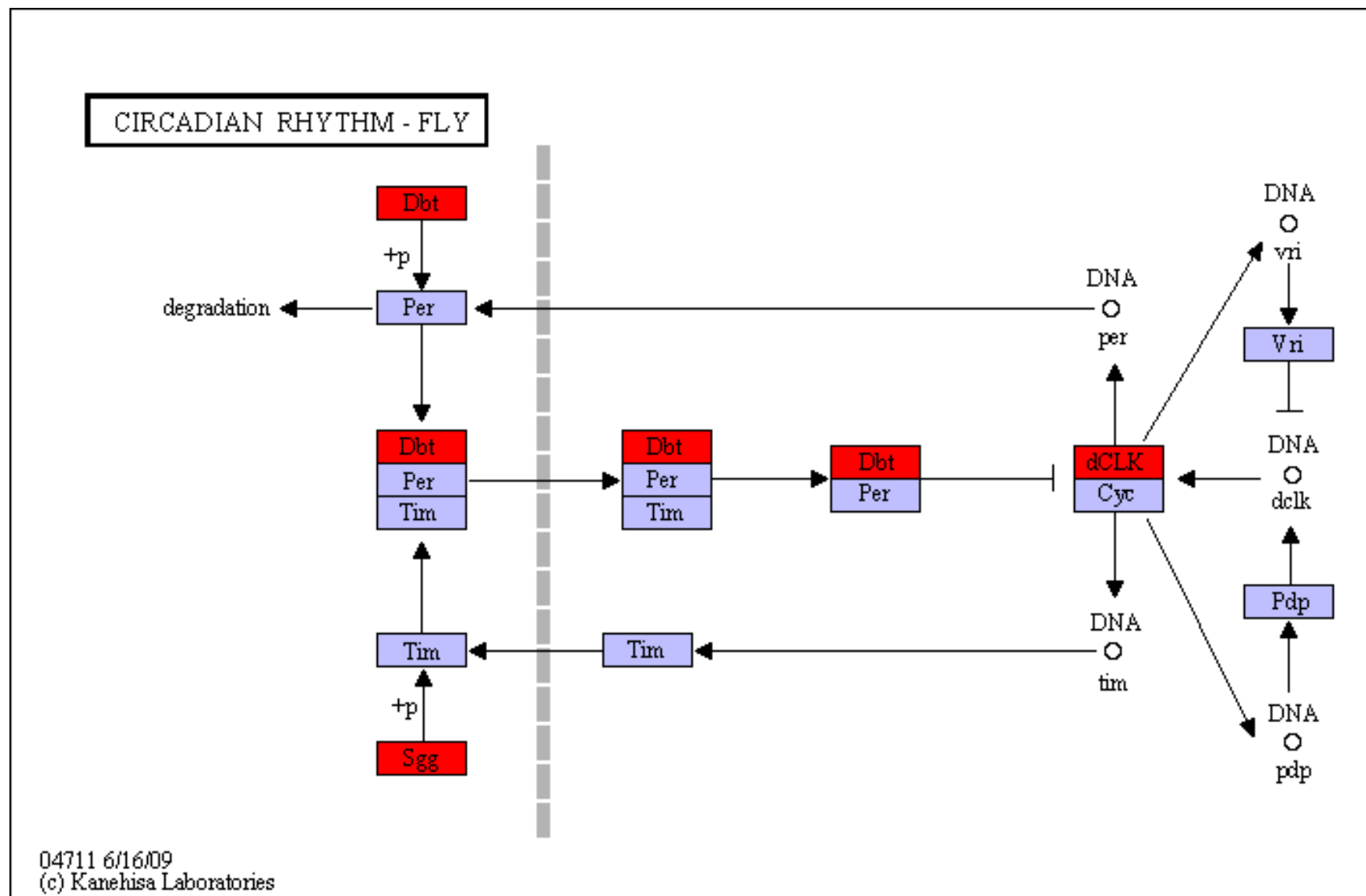
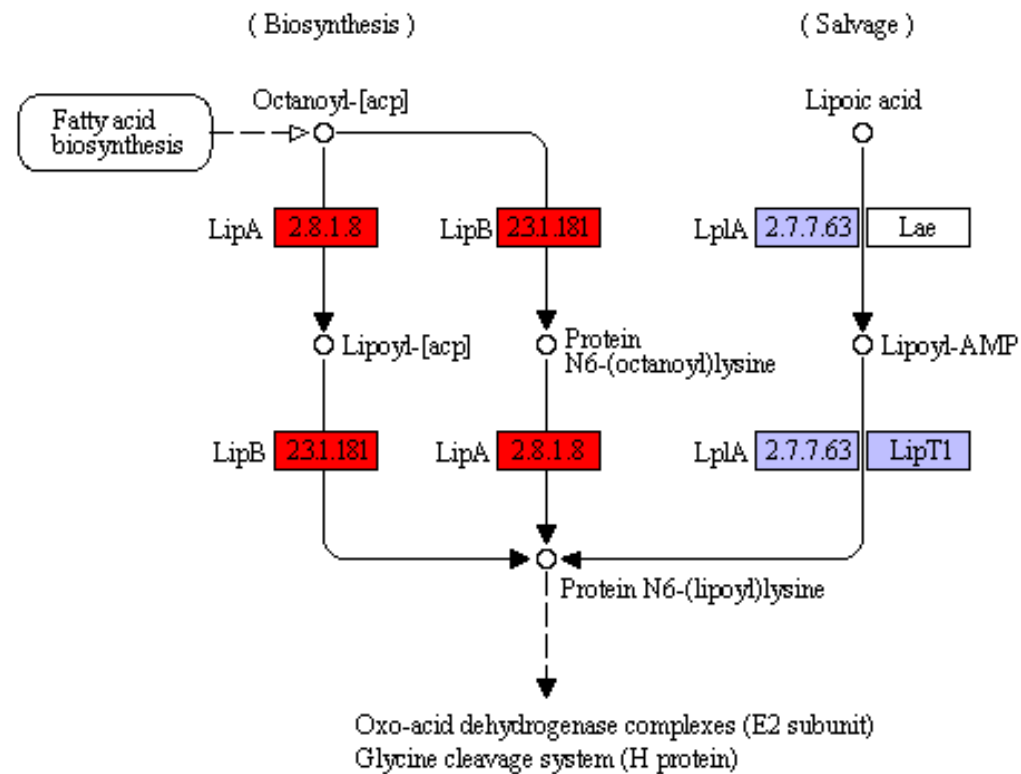

Figure 226: ko04711 Circadian rhythm - fly

## LIPOIC ACID METABOLISM



00785 10/1/09  
 (c) Kanehisa Laboratories

Figure 227: ko00785 Lipoic acid metabolism



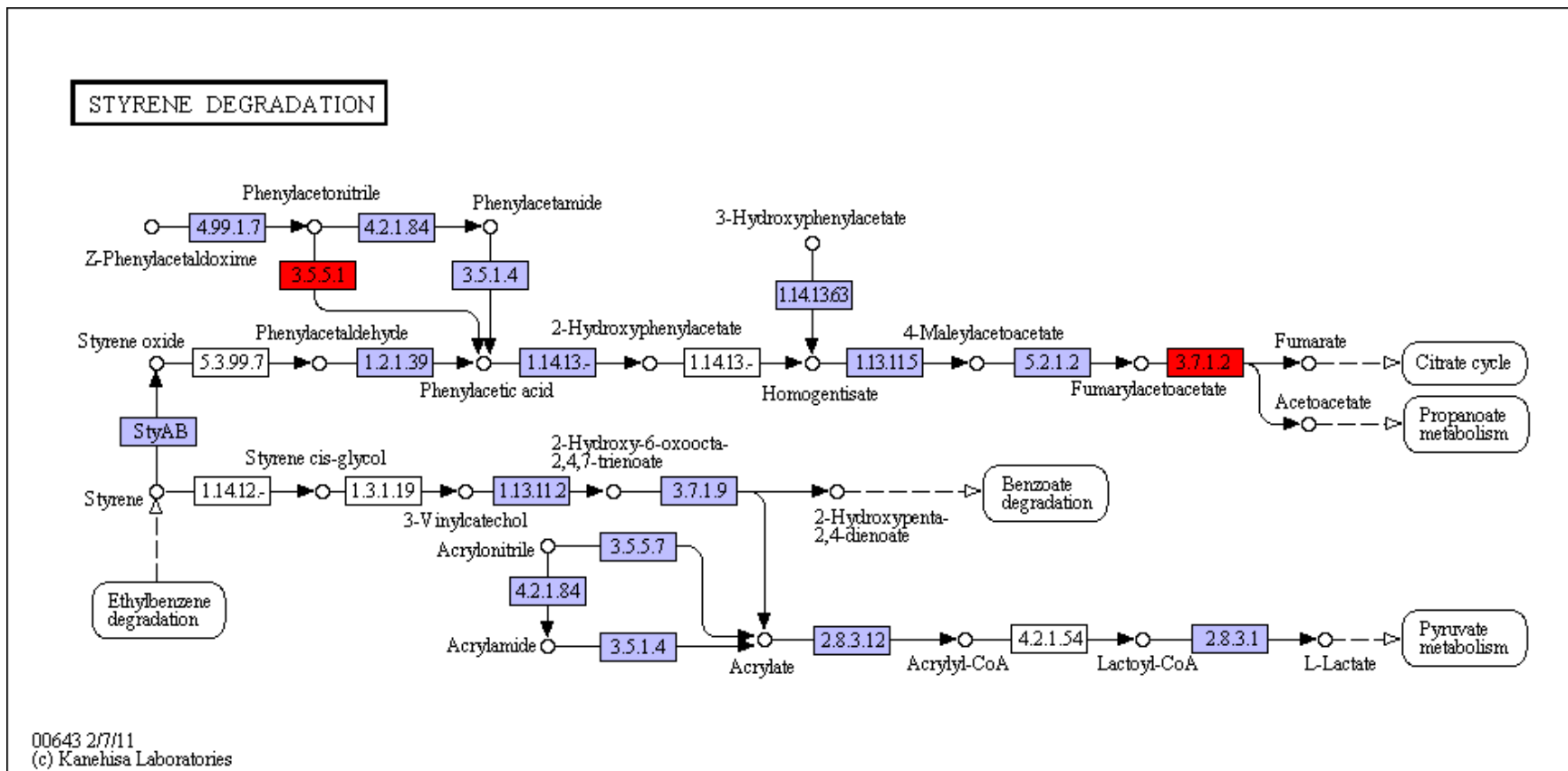

Figure 229: ko00643 Styrene degradation

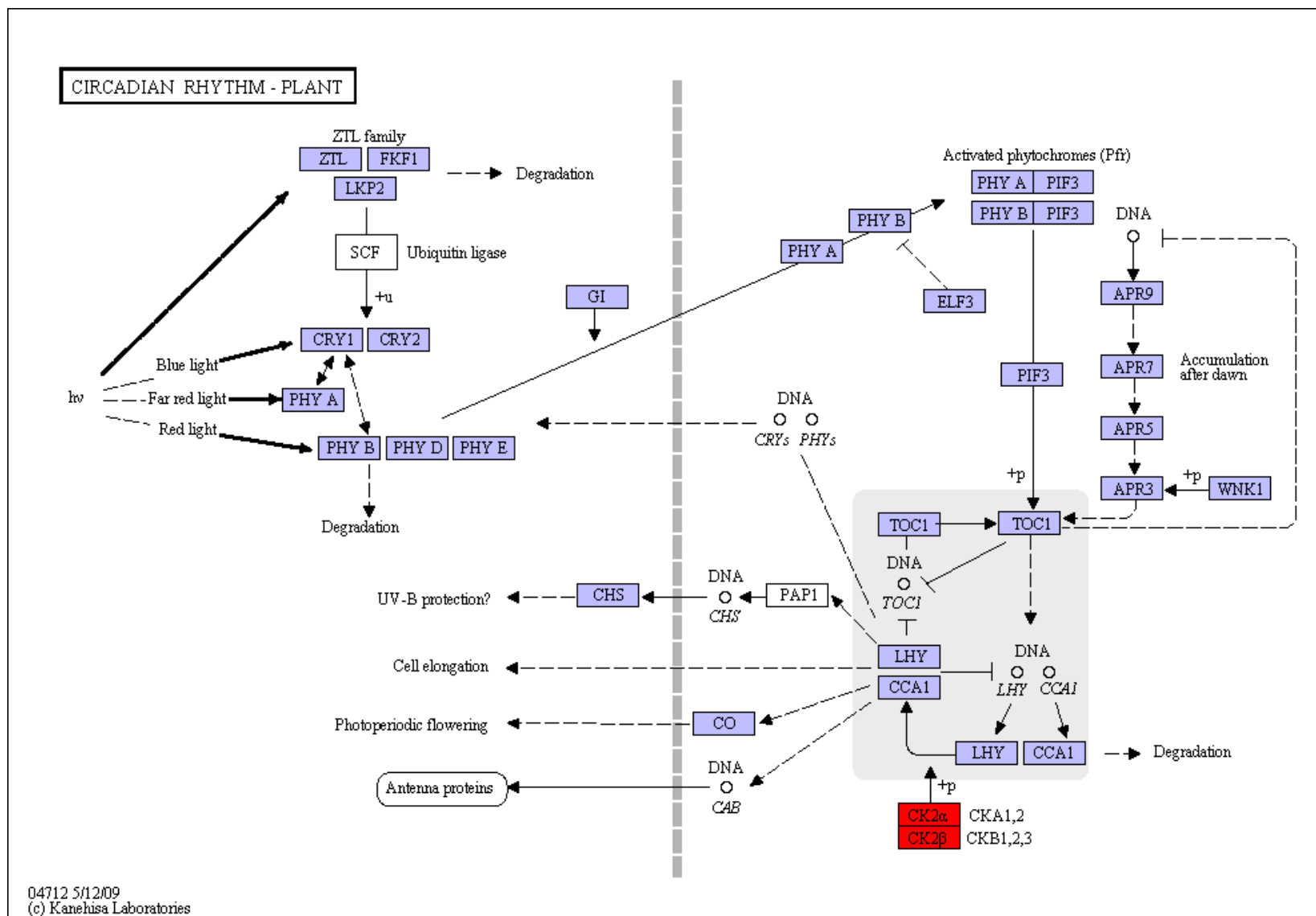

Figure 230: ko04712 Circadian rhythm - plant

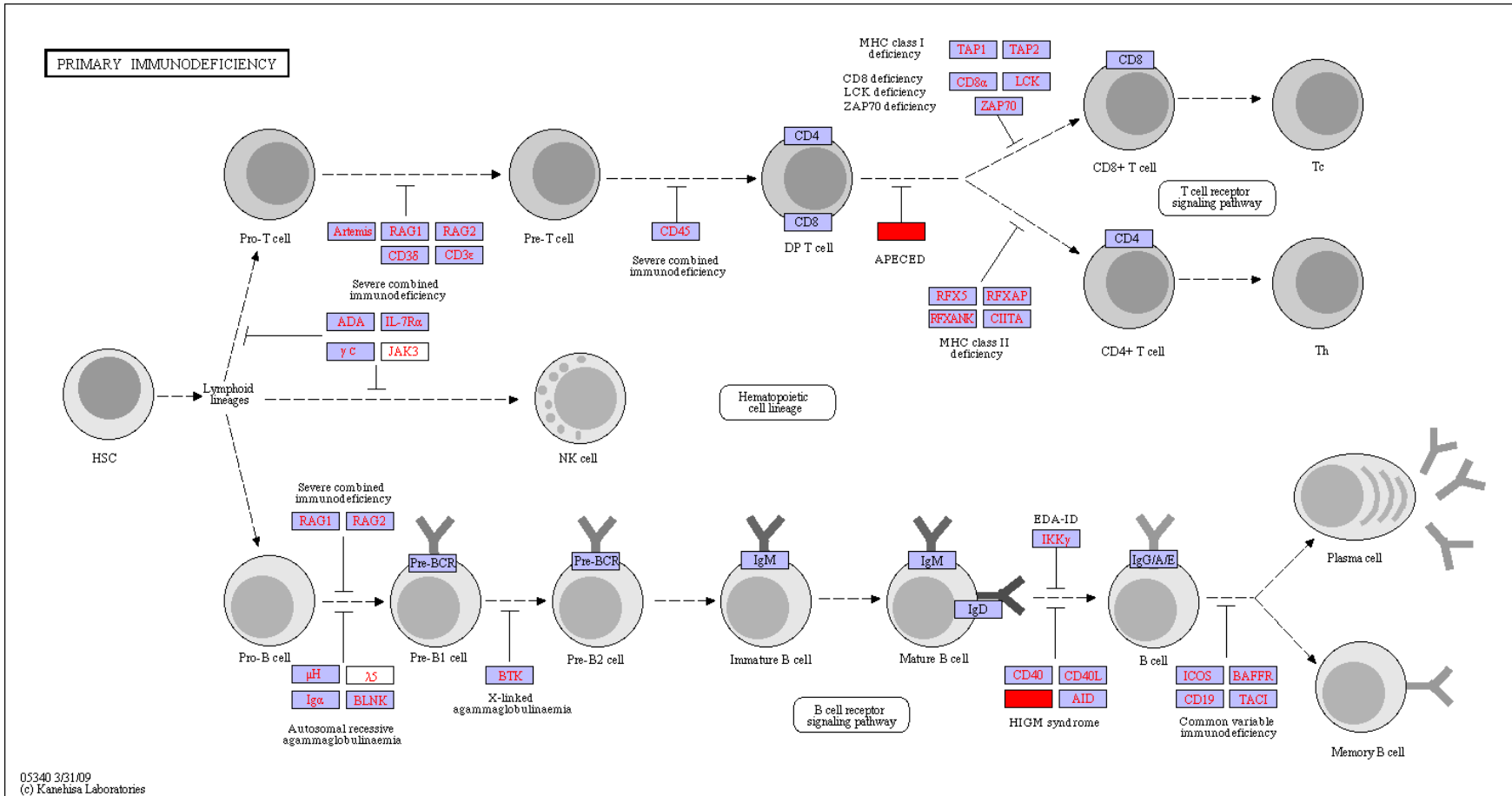

Figure 231: ko05340 Primary immunodeficiency



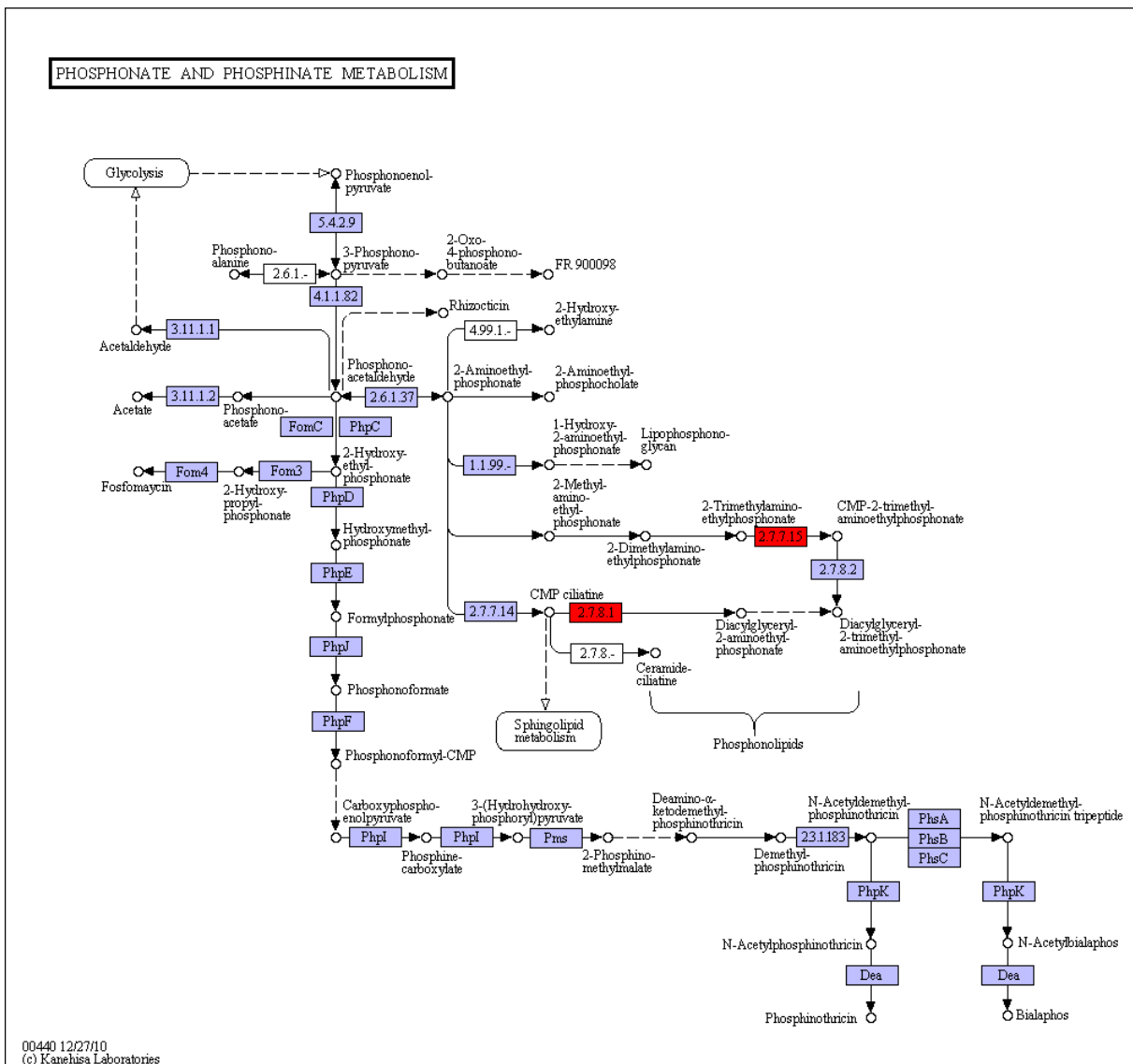
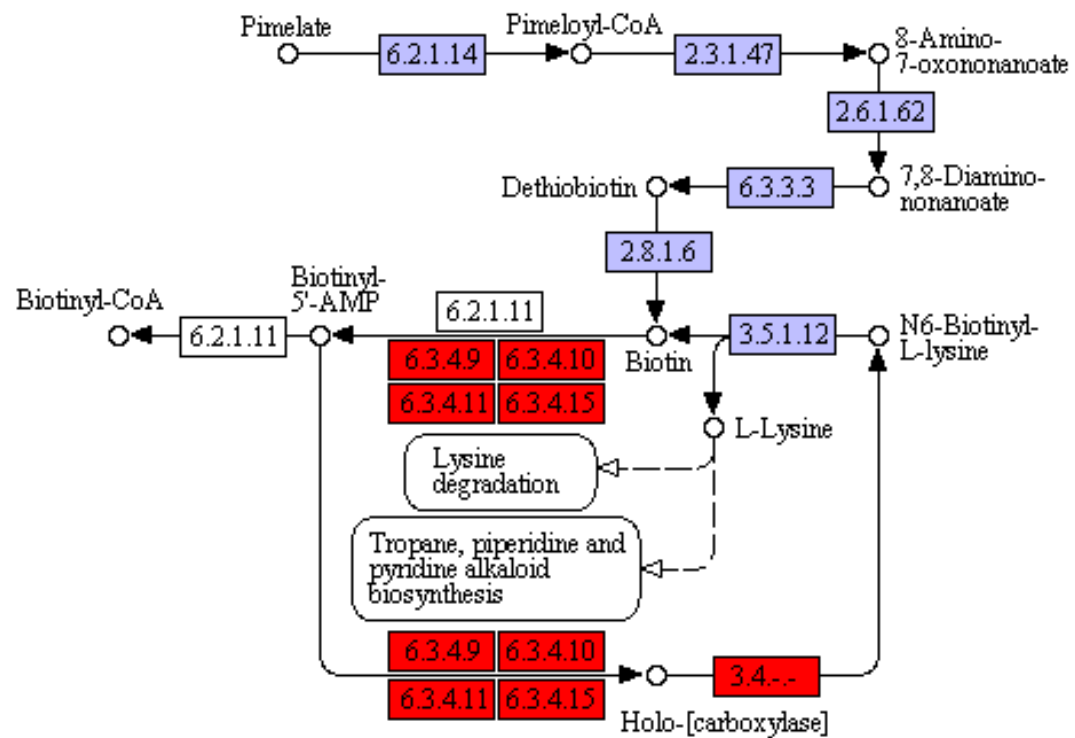

Figure 232: ko00440 Phosphonate and phosphinate metabolism



# BIOTIN METABOLISM



00780 2/2/11  
 (c) Kanehisa Laboratories

Figure 234: ko00780 Biotin metabolism

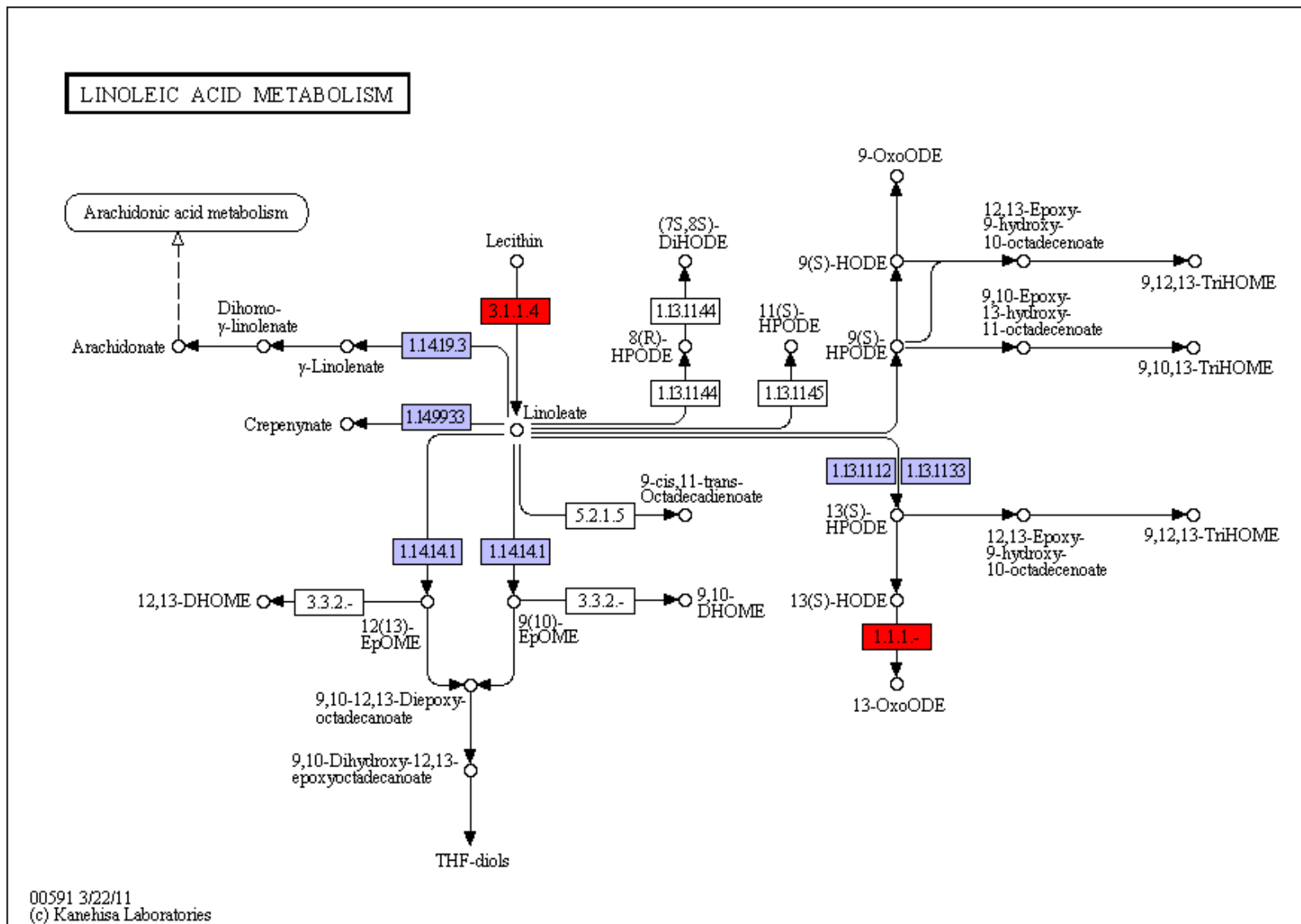

Figure 235: ko00591 Linoleic acid metabolism

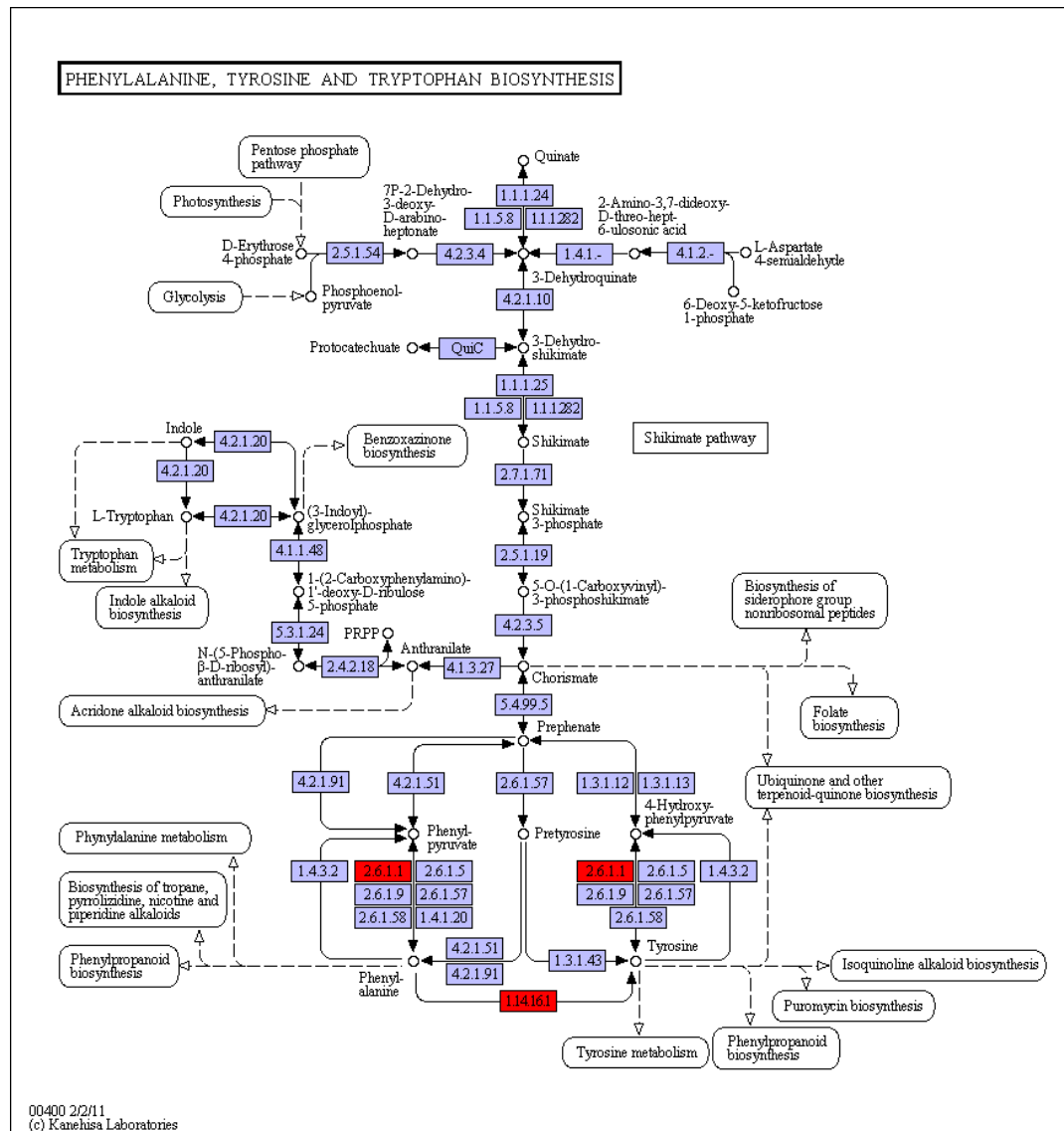
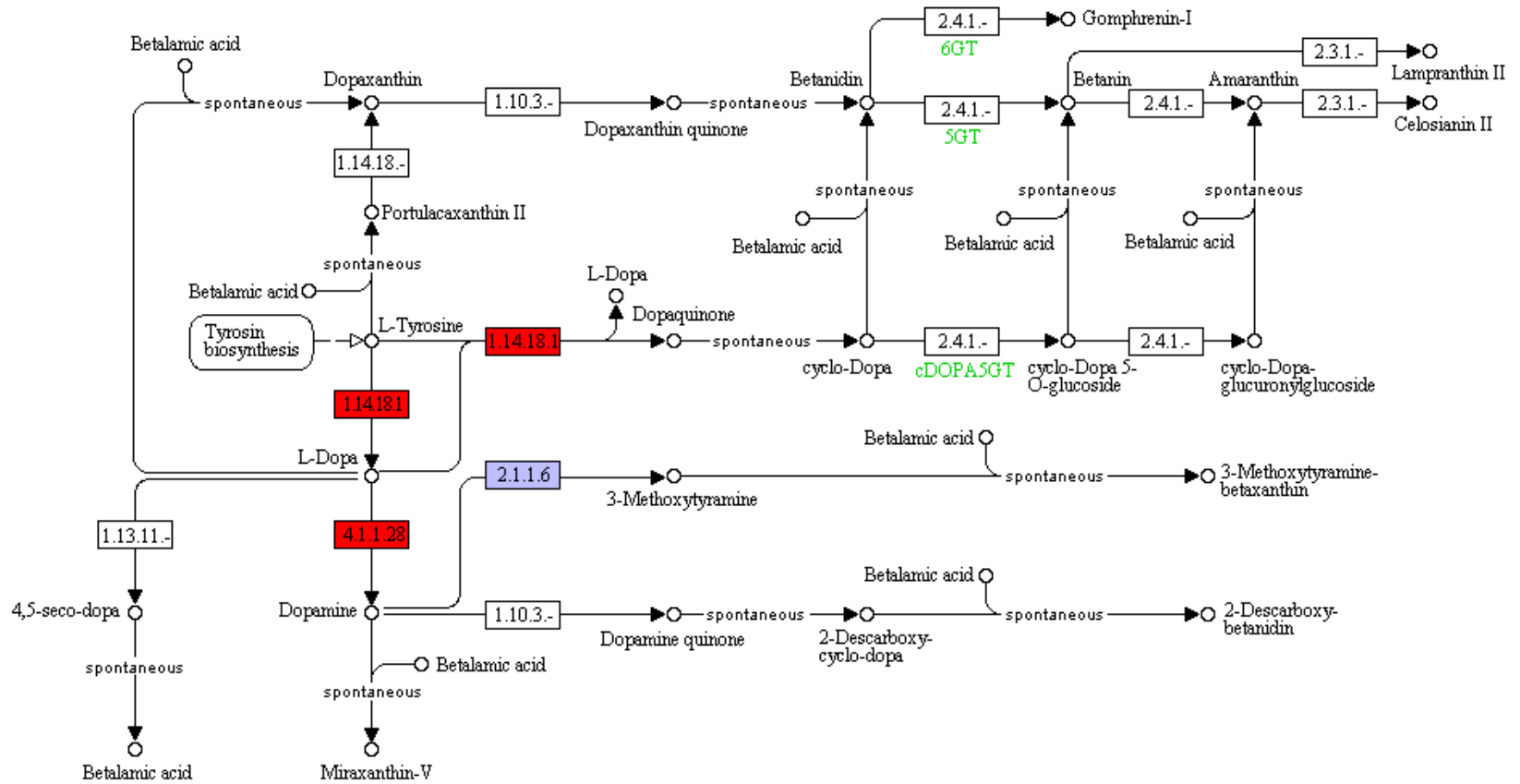

Figure 236: ko00400 Phenylalanine, tyrosine and tryptophan biosynthesis

# BETALAIN BIOSYNTHESIS



00965 9/3/09  
(c) Kanehisa Laboratories

Figure 237: ko00965 Betalain biosynthesis

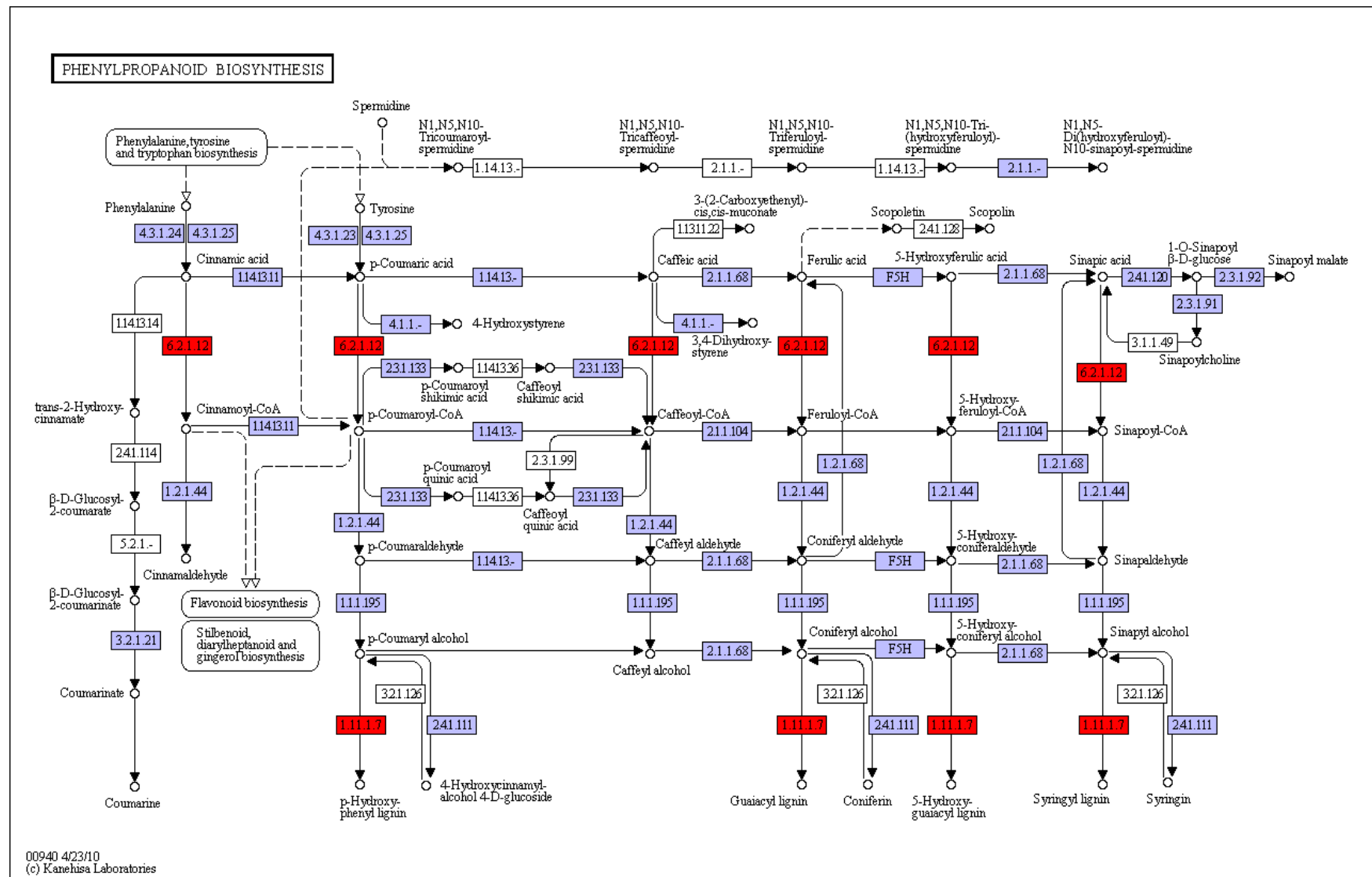

Figure 238: ko00940 Phenylpropanoid biosynthesis

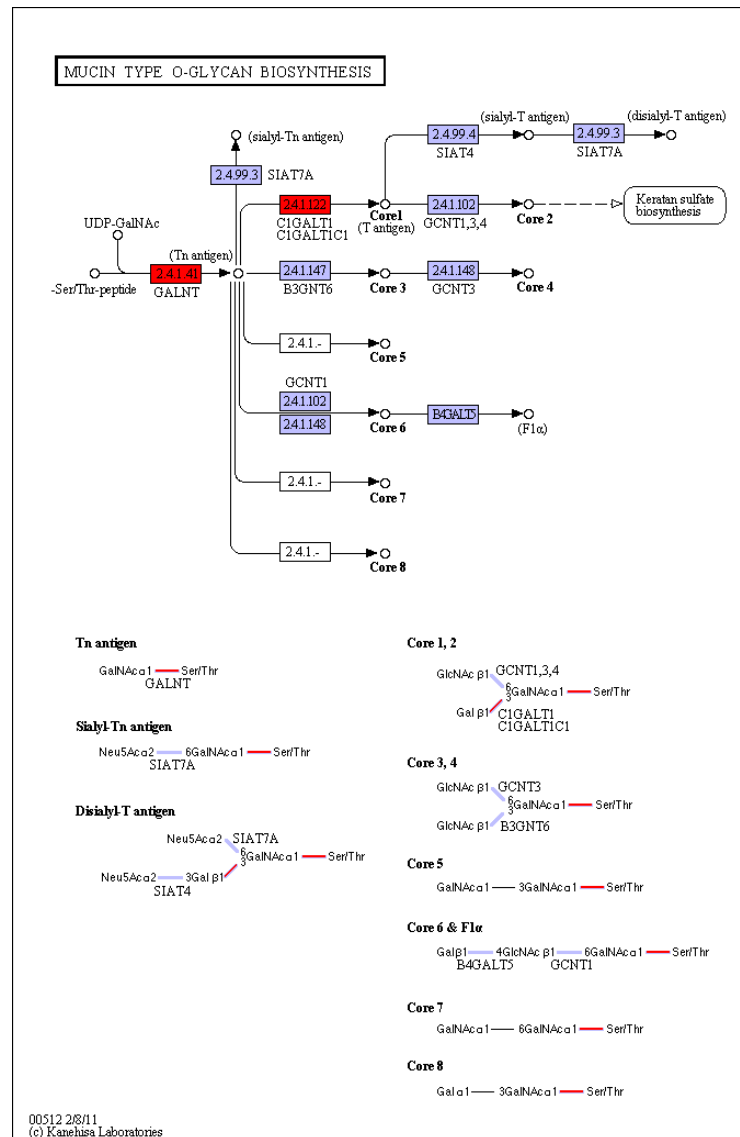

Figure 239: ko00512 Mucin type O-Glycan biosynthesis



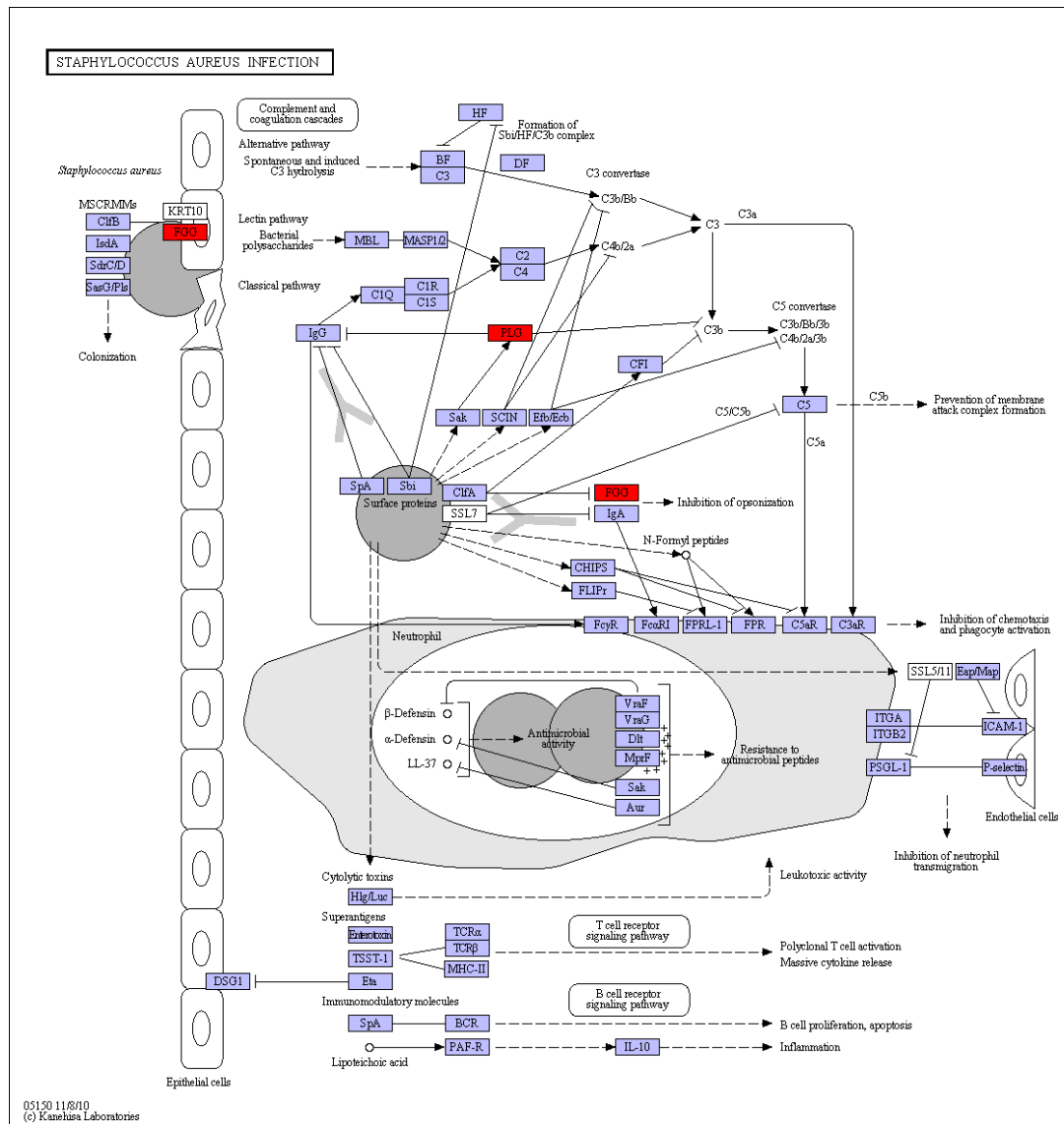
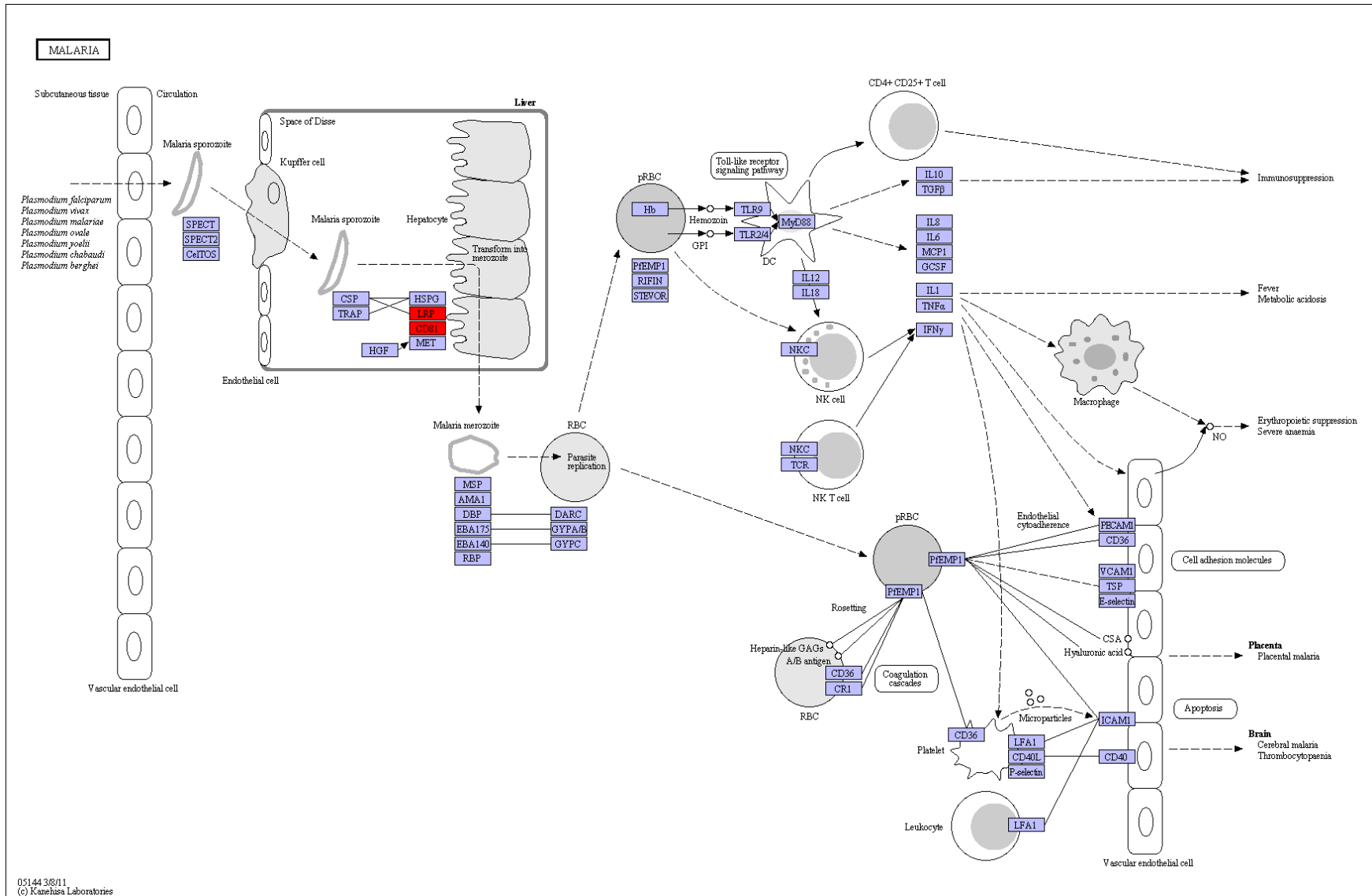

Figure 240: ko05150 Staphylococcus aureus infection



05144 3/8/11  
 (c) Kanehisa Laboratories

Figure 241: ko05144 Malaria



## D-GLUTAMINE AND D-GLUTAMATE METABOLISM

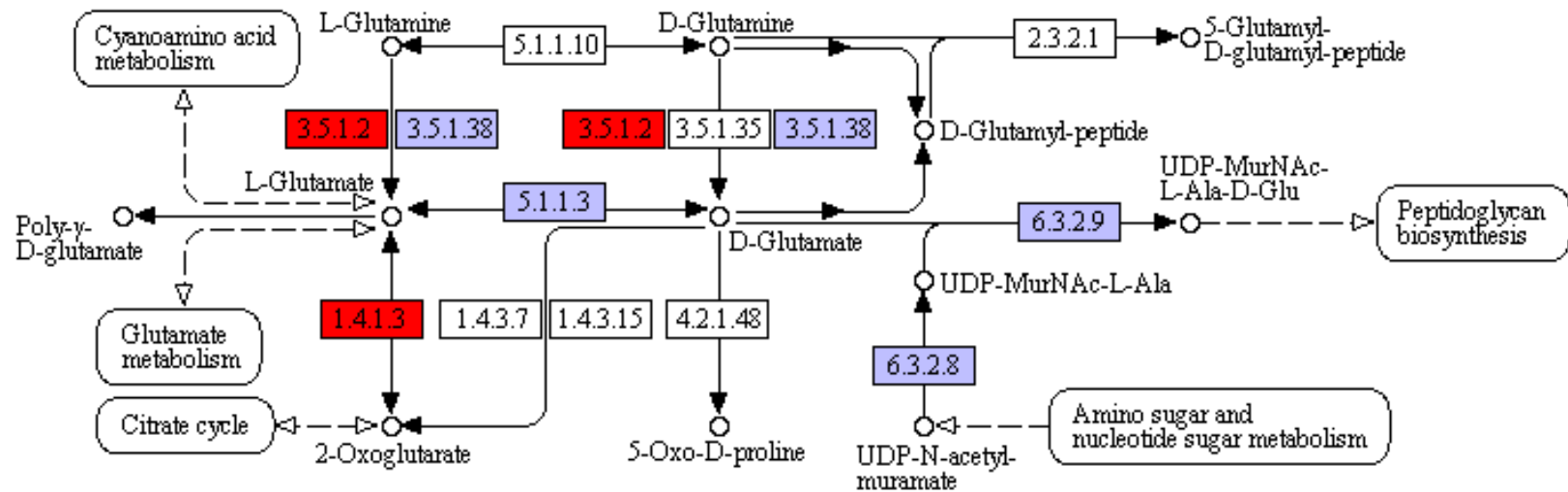

00471 3/14/11  
(c) Kanehisa Laboratories

Figure 243: ko00471 D-Glutamine and D-glutamate metabolism



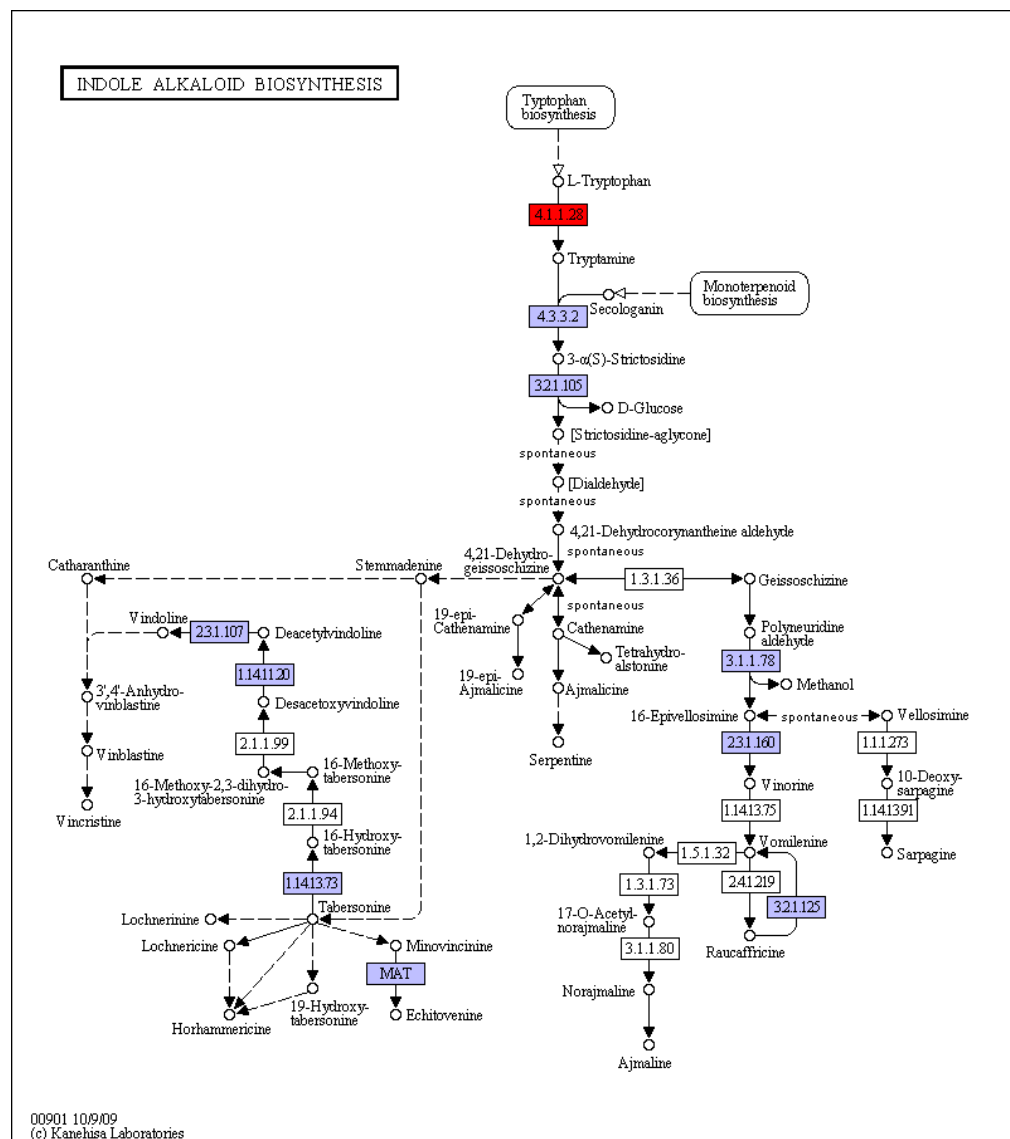

Figure 245: ko00901 Indole alkaloid biosynthesis

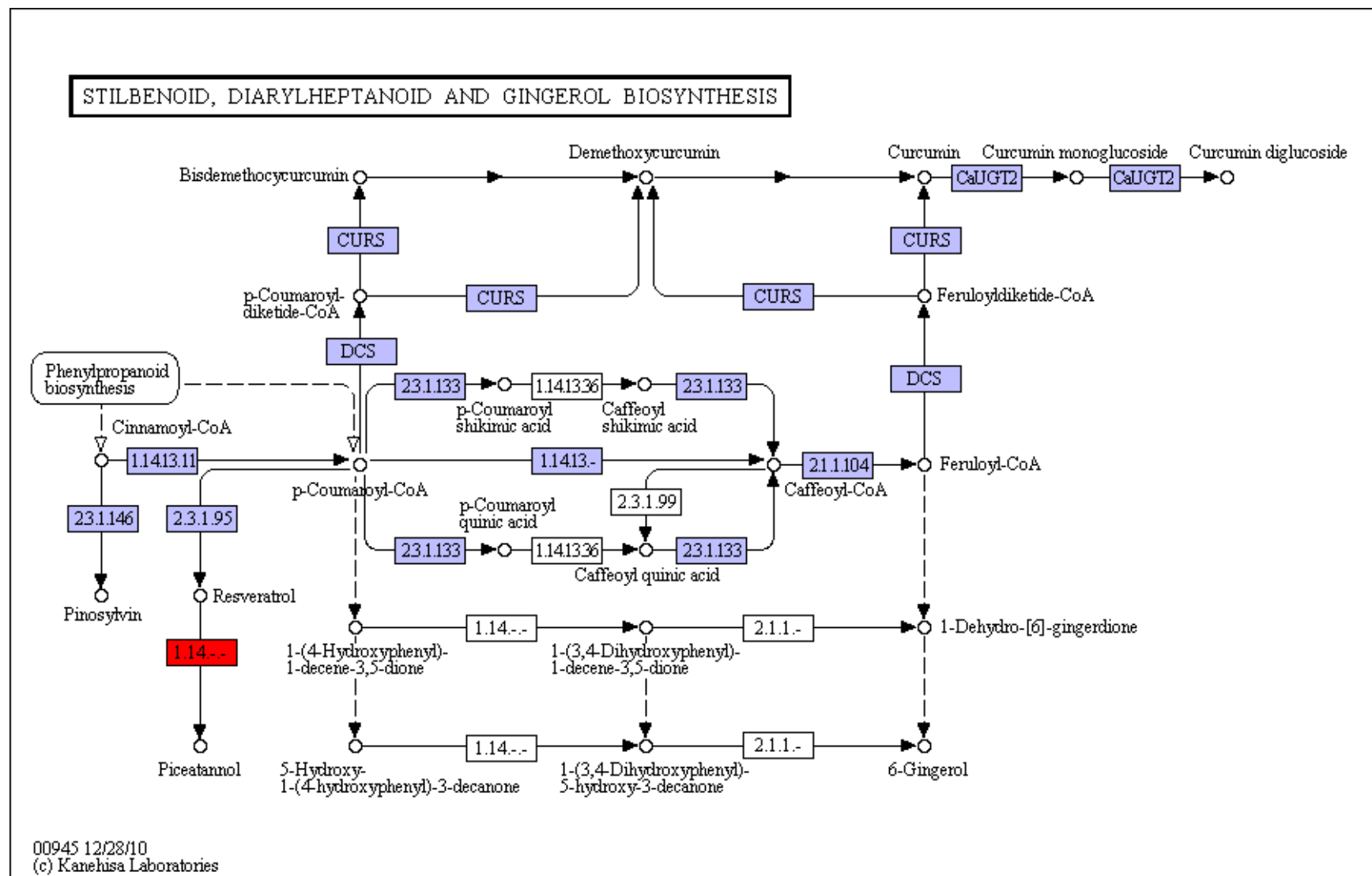

Figure 246: ko00945 Stilbenoid, diarylheptanoid and gingerol biosynthesis

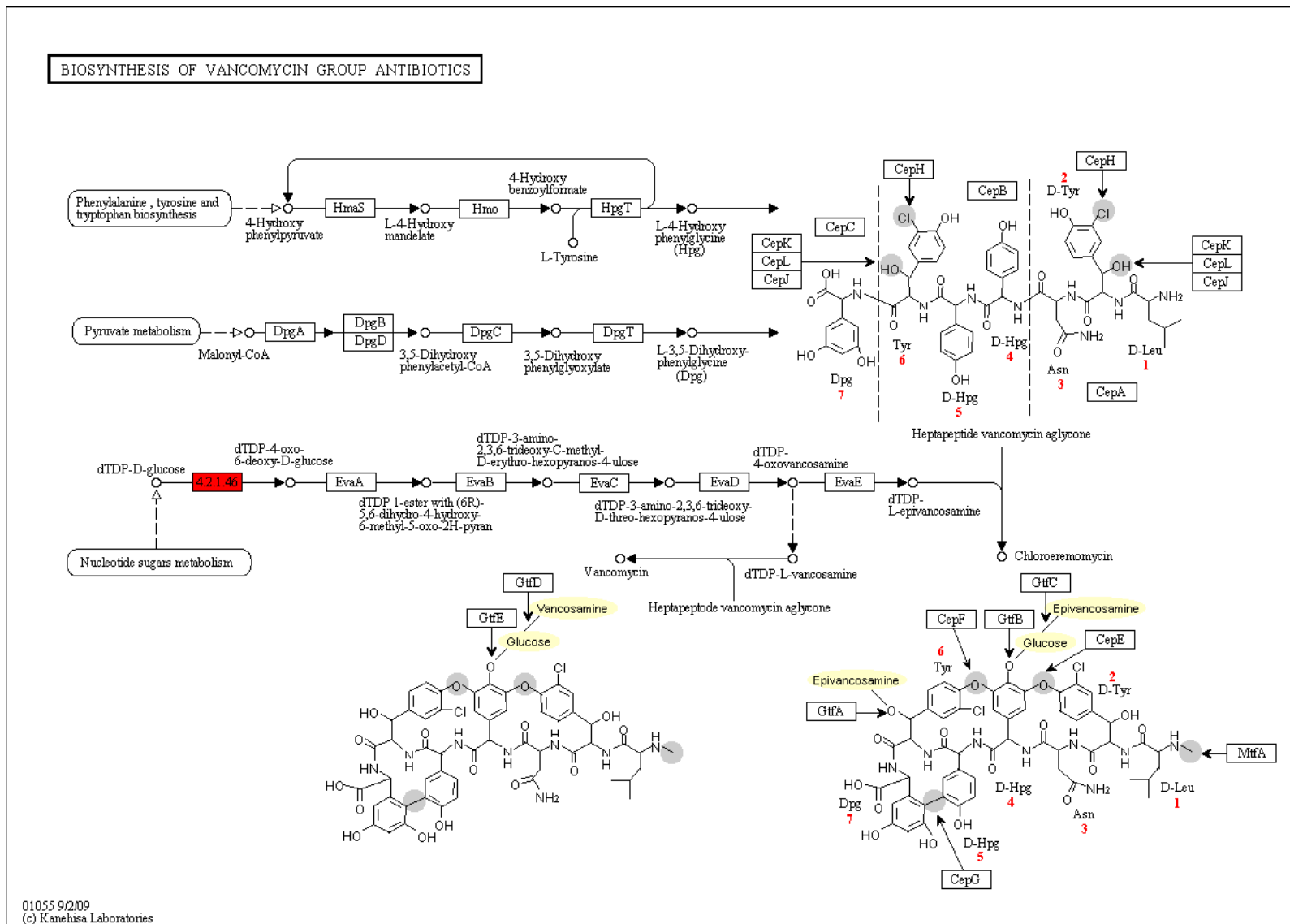

Figure 247: ko01055 Biosynthesis of vancomycin group antibiotics



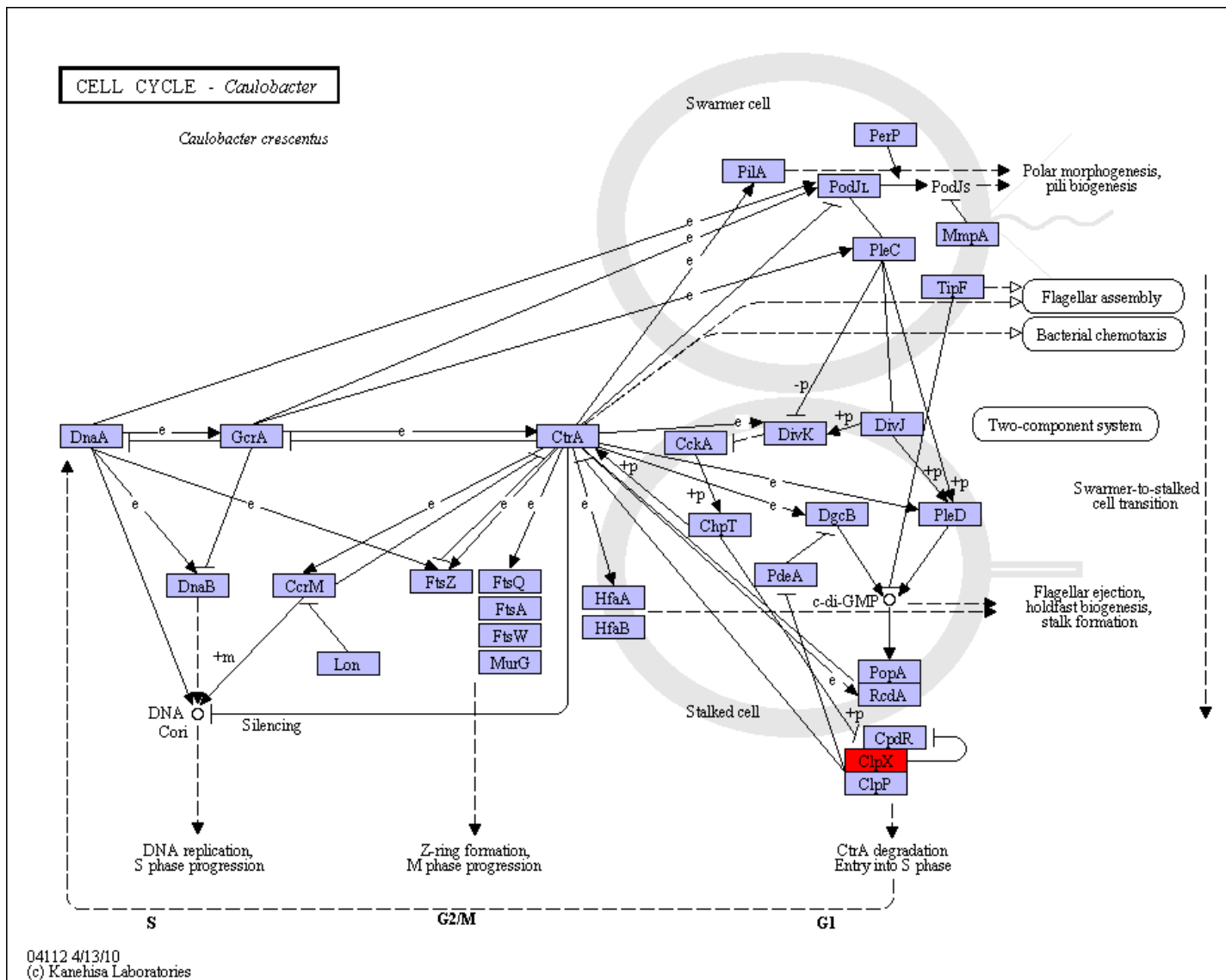

Figure 248: ko04112 Cell cycle - *Caulobacter*

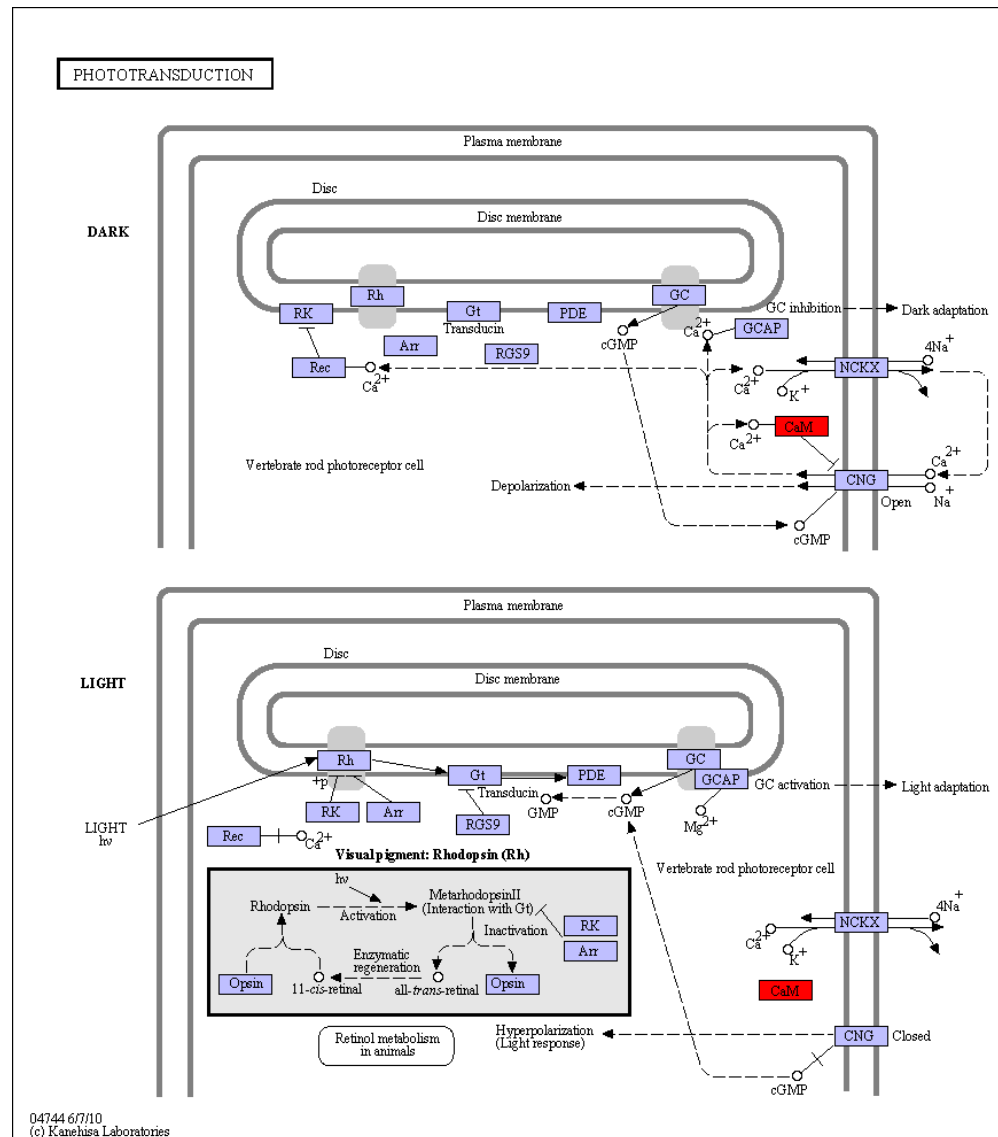

Figure 249: ko04744 Phototransduction

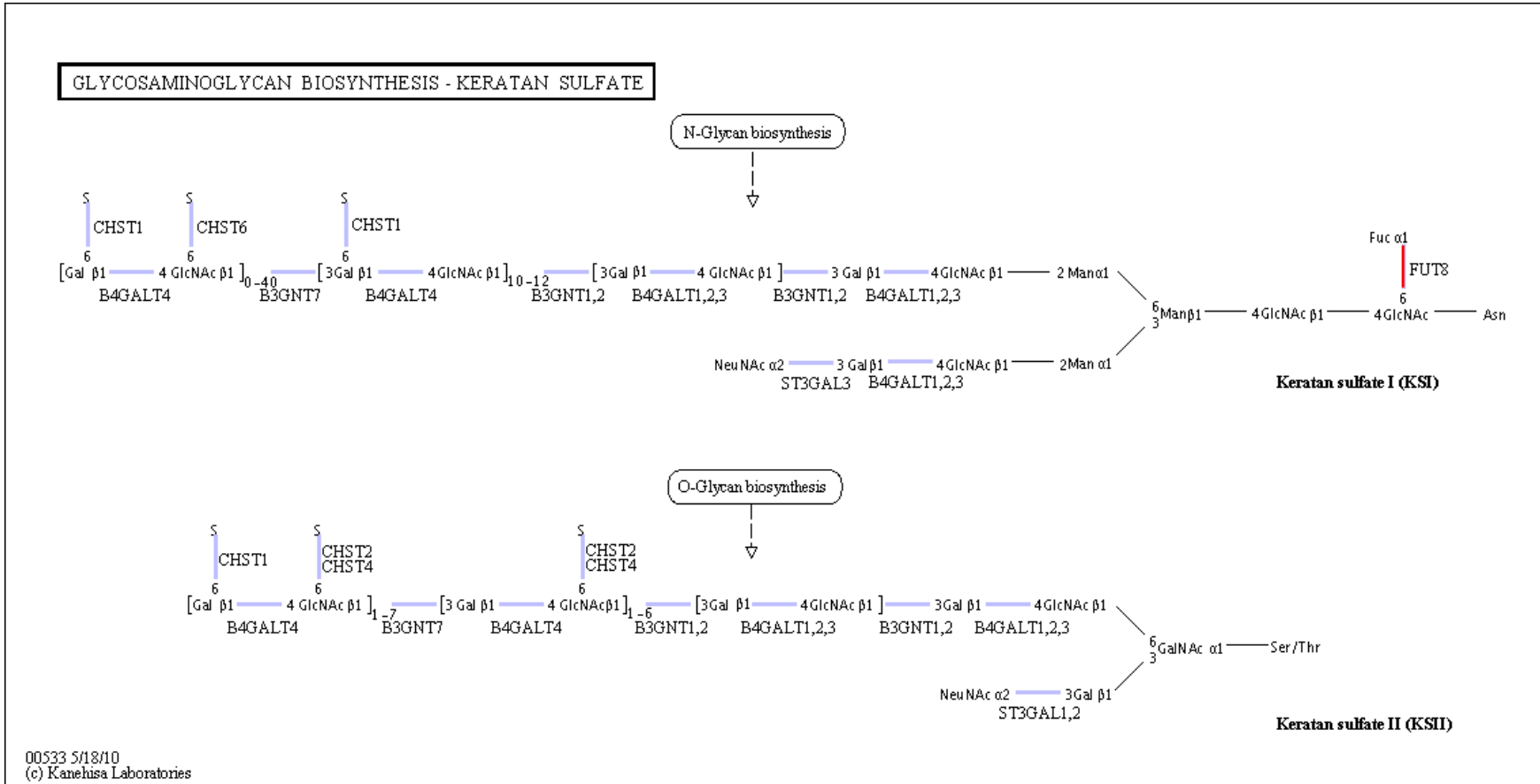

Figure 250: ko00533 Glycosaminoglycan biosynthesis - keratan sulfate

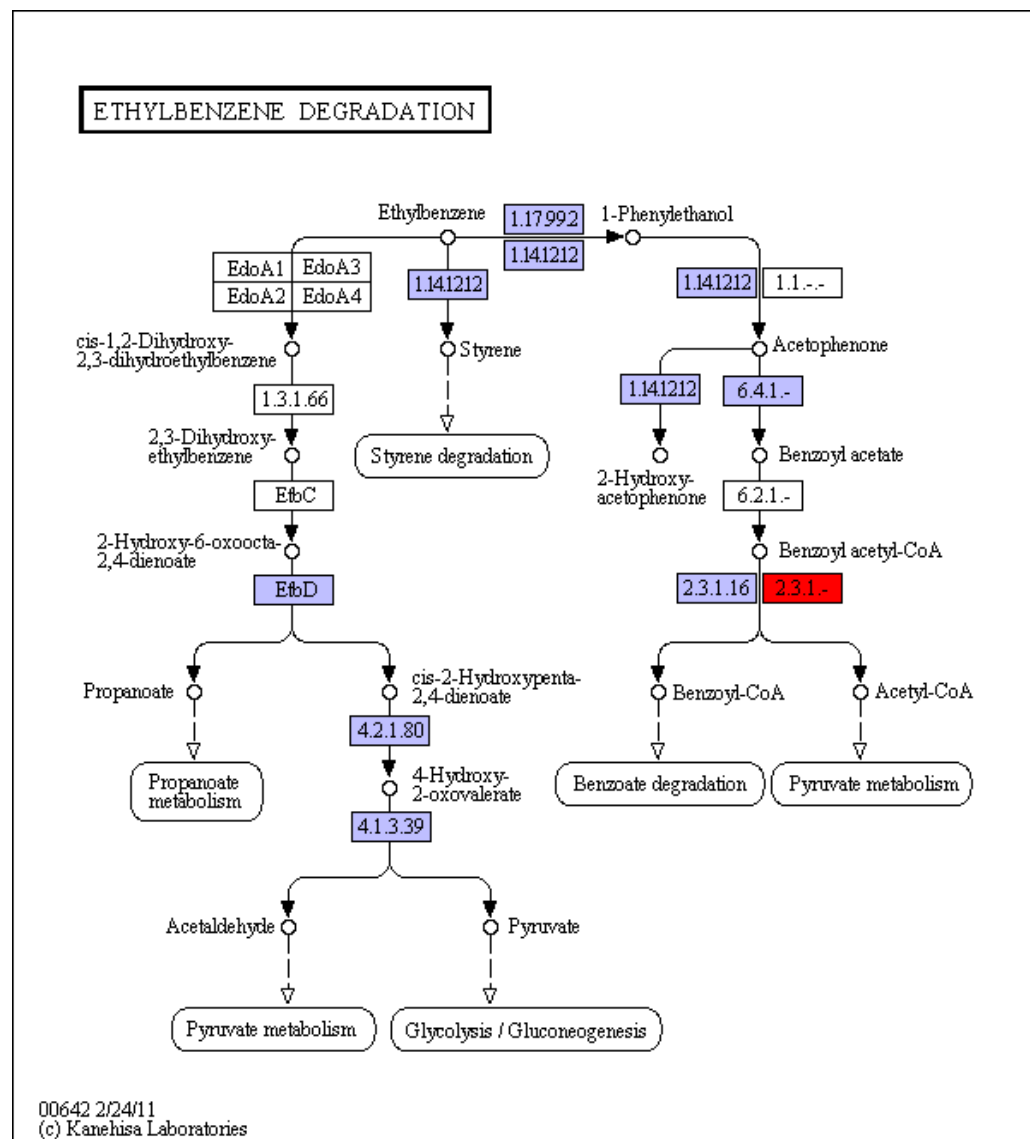

Figure 251: ko00642 Ethylbenzene degradation





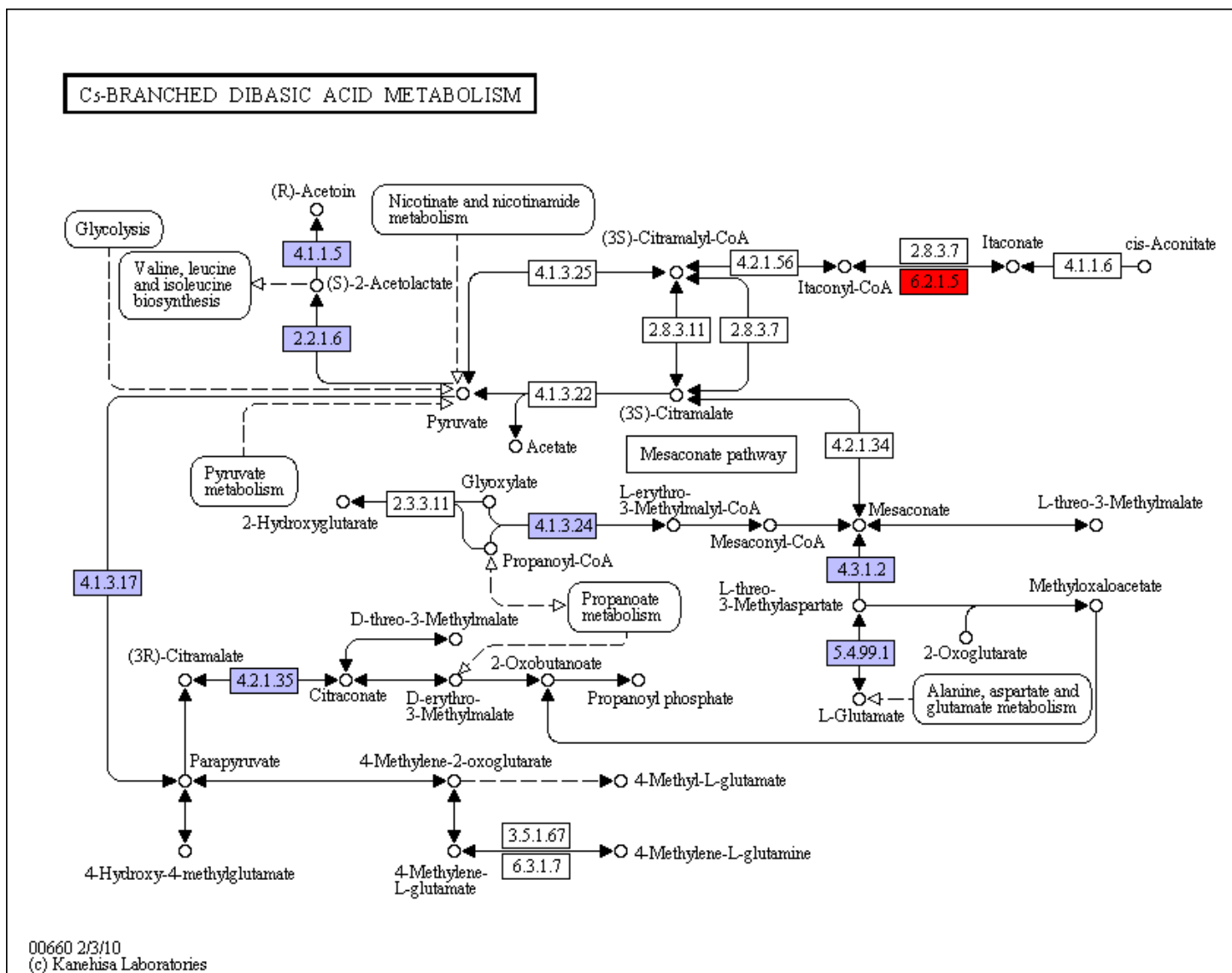

Figure 254: ko00660 C5-Branched dibasic acid metabolism

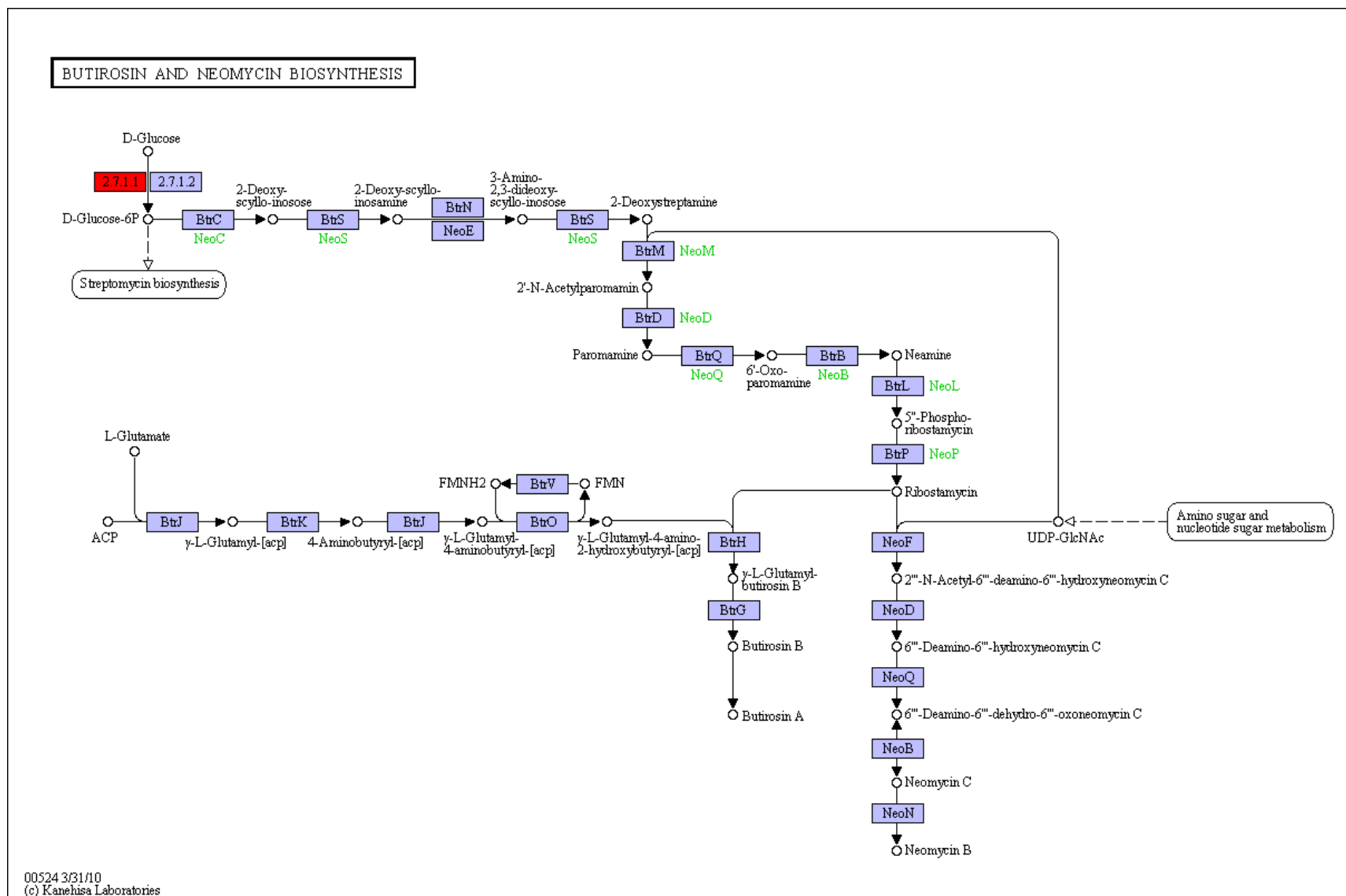

Figure 255: ko00524 Butirosin and neomycin biosynthesis



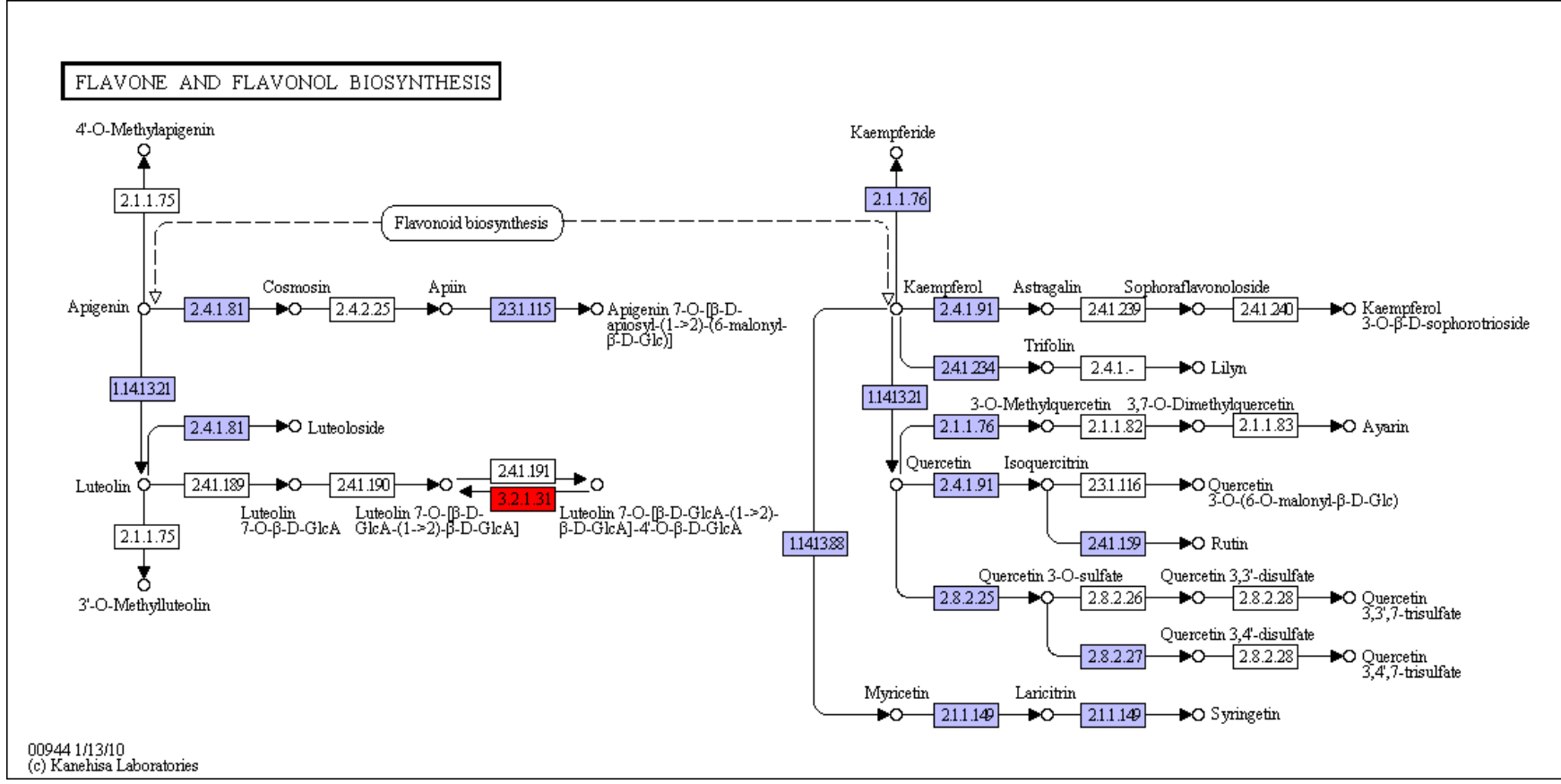

Figure 256: ko00944 Flavone and flavonol biosynthesis

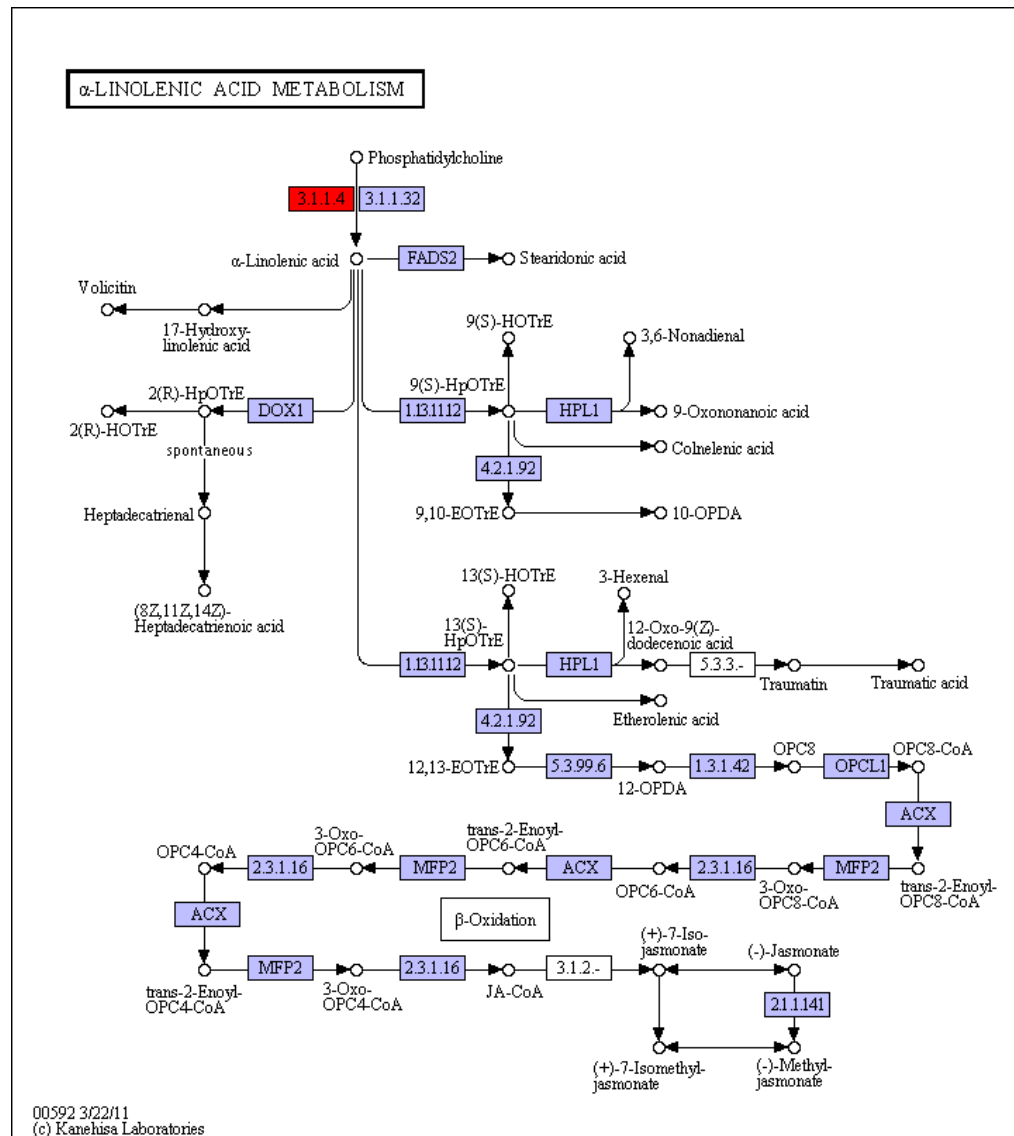

Figure 257: ko00592 alpha-Linolenic acid metabolism









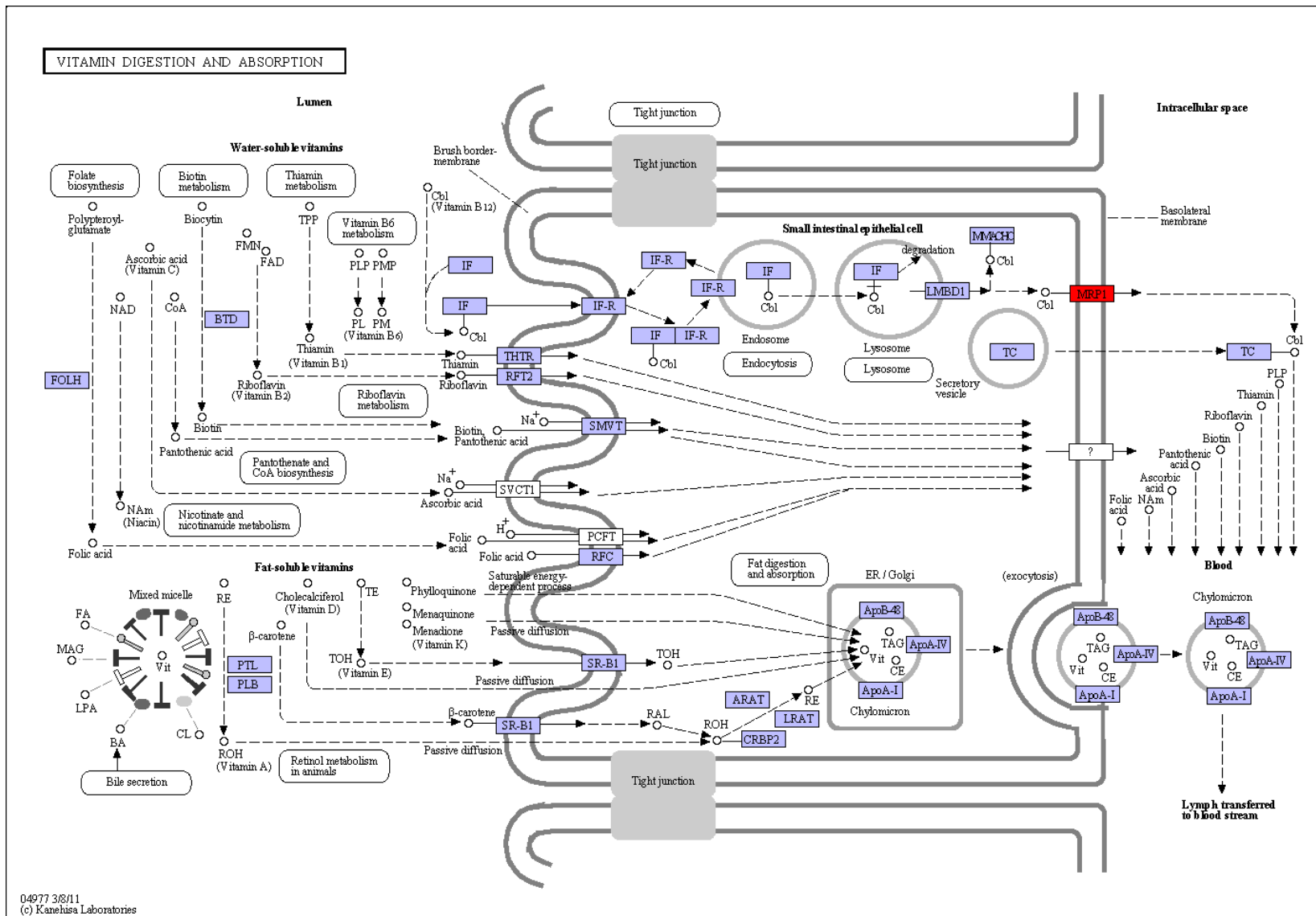

Figure 262: ko04977 Vitamin digestion and absorption