

---

**Functional analysis of the regulatory region of polyoma mutant F9-1 DNA**

---

Ernst Böhnlein, Kamal Chowdhury and Peter Gruss

---

Zentrum für Molekulare Biologie der Universität Heidelberg, Im Neuenheimer Feld 364,  
D-6900 Heidelberg, FRG

---

Received 27 March 1985; Revised and Accepted 14 June 1985

---

**ABSTRACT**

Functional analysis of the transcriptional control region of the polyoma (Py) mutant F9-1 reveals that the mutation is located in a region of Py DNA required for at least two functions. First, an enhancer element which includes the F9-1 mutation was characterized by deletion analysis. This element, described previously as enhancer B (1,2) is essential for viral early gene expression in F9 stem cells whereas enhancer A is unnecessary for transcriptional activity in embryonal carcinoma (EC) cells. Second, a CCACCC motif, present twice in the 3' part of enhancer B is also required in *cis* for the response to a heterologous enhancer. This suggests that a promoter element is present in this region of the polyoma genome which overlaps Py enhancer B. We also demonstrate the enhancement of the polyoma early promoter activity in F9 stem cells by MBV sequences. The significance of these observations is discussed.

**INTRODUCTION**

The molecular basis of differentiation processes is not understood but regulation of several genes examined takes place at the transcriptional level (8,9). Therefore, an understanding of transcriptional control mechanisms seems to be essential for the deciphering of differentiation pathways. For these analyses, embryonal carcinoma (EC) cells (10) and especially the F9 cells are particularly useful model systems as they allow the study of molecular details of certain differentiation steps (see 11 for review).

Polyoma (Py) is a murine DNA virus that induces tumors in many different tissues (see 3 for review). The noncoding region located between the early and late transcription unit has attracted attention since it is thought to contain enhancer elements (4,5) and other *cis*-acting elements essential for early gene expression and viral replication (6,7). Comparison of DNA

sequences of the wild-type virus which is restricted in its ability to grow in EC stem cells and those of mutants selected for growth in these cells (12-17) initially indicated regions important for the regulation of transcription. In particular, polyoma mutants growing in EC cells contain deletions, reiterations and point mutations in the noncoding region and show a pattern specific for the EC cell lines in which they were selected. Mutants derived in PCC4 cells carry duplications of sequences that contain enhancer A which is contained on a Bcl I/PvuII-fragment (nucleotide #5021-#5128 according to the numbering system of Soeda *et al.* (32)) and deletions of sequences contained in the PvuII-4 fragment (#5128-#5262) (12,13) whereas F9 cell specific mutants have duplications and mutations in the PvuII-4-fragment that contains enhancer B (15,16). The transcriptional activity of heterologous promoters in EC stem cells was increased only by polyoma mutant regulatory sequences, indicating that this effect results from an altered enhancer function (1,2).

We were interested in defining the function which was affected in the simplest mutant growing in F9 cells, F9-1 (12), that contains a single point mutation in its sequence compared to wild-type strain A3 (18). The regulatory region of PyF9-1 (BamH1/HphI:#4631-#163) was therefore cloned upstream of an indicator gene (CAT) lacking any transcriptional control elements (see Fig.1), such that transcriptional activity after transfection in mouse cells (F9, fibroblasts) must derive from the polyoma fragment inserted. Using this experimental approach we were able to map the 5' border of the enhancer B element that is essential for gene expression in F9 cells. Deletions at the 3' end of the PvuII-4 fragment eliminating the point mutation result in a loss of the enhancer activity. Overlapping this enhancer is another transcriptional element which includes the mutation and has structural and functional homology to the SV40 21-bp repeats. Since this Py element is necessary to detect activity of heterologous enhancers (SV40, MSV) in mouse fibroblasts and F9 cells it can be considered an upstream element of the polyoma early promoter.

---

## MATERIALS AND METHODS

### Cell Culture, Transfections and CAT Assays

Mouse fibroblasts (LTK<sup>-</sup>, NIH3T3, NIH3T6) were grown in Dulbecco's modification of Eagle's Medium (DMEM,Boehringer) with 10% fetal calf serum (FCS,Flow Laboratories) in the presence of penicillin and streptomycin. F9 teratocarcinoma cells were grown in DMEM/10% FCS with high glucose and antibiotics. F9 cells were passaged frequently in order to avoid high cell density but not exceeding ten times. Transfections were performed in one of two different ways: One was a modification of the DEAE dextran procedure (19) using 10 µg of plasmid DNA per 10 cm dish. The calcium-phosphate transfection procedure was performed using 25 µg plasmid DNA (20,21). The DEAE dextran method was only used for the LTK<sup>-</sup> cells. Fibroblast cell lines were transfected using calcium-phosphate. In each case, one million cells were plated per 10 cm dish prior to transfection. The EC cells were plated at a density of  $5 \times 10^5$  cells per dish after passage through a needle or a Nitex membrane in order to remove cell clumps. After addition of the calcium-phosphate precipitate the plates were incubated overnight. The next day, cells were washed twice with TBS (3 mM EGTA). Following incubation for another 24 hours, cells were harvested using a rubber policeman and disrupted in 200 µl Tris-HCl pH 7.8 using a sonifier. CAT assays and their quantitative measurement were performed using these extracts according to previously published protocols (21,22).

### Bal 31 Deletion Mutants

To analyze the early transcriptional signals contained in the noncoding region of polyoma F9-1 region we used a procedure that generated unidirectional viral deletion mutants. A recombinant (Fig.1) that contained the polyoma F9-1 BamH1/HphI fragment (#4631-#163; #163 is the recognition site of HphI, the cutting site is 7 bp upstream) upstream of a promoterless CAT gene in the orientation indicated was linearized with Bcl I and treated with Bal 31 nuclease (New England Biolabs) for various times as described by Maniatis *et al.* (23). Thereafter, the termini of the resulting DNA molecules were treated with T4 DNA polymerase (PL-Biochemicals) and converted to BamH1 ends by addition of linkers (New England Biolabs). The mixture was then

digested extensively with BamH1 restriction endonuclease and ligated using T4-DNA ligase (Boehringer) under conditions that yielded mainly circular molecules. Subsequently the ligated mixture was transfected into E. coli HB101 (24). Minipreparations of plasmid DNAs (23) were analyzed with restriction endonucleases and viral deletion mutants of interest were sequenced using the chemical procedure (25).

### RNA Preparations

Cytoplasmic RNA was isolated after transfection of 10 µg of plasmid DNA per 10 cm dish using the DEAE-dextran procedure (19). After 40-48 hours, cells were washed twice with PBS and harvested with a rubber policeman. The cell pellet was washed twice with a solution containing 140 mM NaCl, 1.5 mM MgCl<sub>2</sub>, 10 mM Tris-HCl pH 7.5. To this solution 10% NP 40 was added to a final concentration of 0.5%. The DNA in the lysate was sheared and cellular debris was removed by centrifugation in an Eppendorf centrifuge for 5 minutes at 4°C. The supernatant was extracted twice with phenol/chloroform/isoamyl alcohol (25:24:1) and ethanol precipitated. Total RNA was prepared according to published methods (26).

### S1 Nuclease Mapping Experiments (23)

Either 50 µg of total RNA or the cytoplasmic RNA from two 10 cm dishes were pelleted and resuspended with a buffer containing 80% formamide, 10 mM Pipes pH 6.4, 400 mM NaCl, 1 mM EDTA and an excess of <sup>32</sup>P 5' labelled single stranded DNA probe. The mixture was heated to 85°C for 10 minutes and hybridized at 42°C overnight. The hybridization mixture was then treated with S1 nuclease (Sigma) by adding 300 µl of 30 mM sodium acetate pH 4.6, 280 mM NaCl, 4.5 mM zinc sulfate, 30 µg/ml denatured calf thymus DNA and 70 to 250 units S1 nuclease. The nuclease reaction was incubated at 18°C for at least 90 minutes and stopped by phenol extraction and ethanol precipitation. After being washed twice with 75% ethanol the pellet was resuspended in loading buffer (23) and analyzed on a denaturing polyacrylamide gel.

## RESULTS

### Experimental Design

In order to facilitate the functional analysis of a large number of different mutants, we employed the chloramphenicol

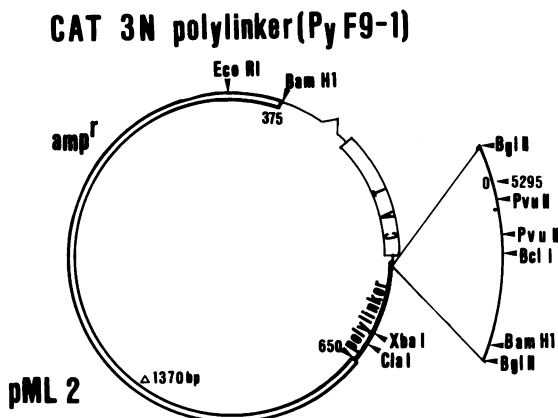

**Fig. 1:** The plasmid CAT3N polylinker was constructed by ligation of the large Bam HI/Sal I fragment of pML 2 (47) and the Hind III/Bam HI fragment of pSV0-CAT (27). The Sal I/Hind III fusion was done by insertion of a polylinker sequence whereby both sites were destroyed. For further manipulations the Bam HI site at the fusion was destroyed using T4 DNA-polymerase (PL Biochemicals). The recombinant plasmid PyF9-1 CAT was obtained by insertion of the Bam HI(#4631)/Hph I(#163) fragment of the polyoma F9-1 mutant in the Bgl II site of the vector CAT3N polylinker using Bgl II linkers in the orientation indicated. Using this protocol 6 nucleotides of the Bgl II-linker were added at each end of the fragment and the Bam HI site in the polyoma sequence was retained. Therefore, in this plasmid, PyF9-1 CAT, all transcriptional elements upstream of the CAT gene were of polyoma origin. The downstream splicing and polyadenylation signals are derived from the SV40 genome.

acetyl transferase (CAT; EC2.3.1.99) gene as test system. In this system, the quantity of CAT expressed is dependent on the enhancer and promoter used (27-30). As an enhancer/promoter fragment we selected a BamHI/HphI fragment (#4631-#163) from either polyoma wild-type (strain A3) or polyoma F9-1 mutant (12). The fragments were cloned using synthetic oligonucleotides (Bgl II linkers) into a plasmid-vector equivalent to pSV0 CAT (29; Fig. 1). Neither enhancer nor promoter sequences are present in this vector. Adjacent to the 3' end of the procaryotic CAT gene are an intron and a polyadenylation signal from SV40 DNA (21). The polyoma fragment selected includes all major start sites for early transcription of polyoma virus (3,31). Thus, insertion of this fragment in the sense orientation places the

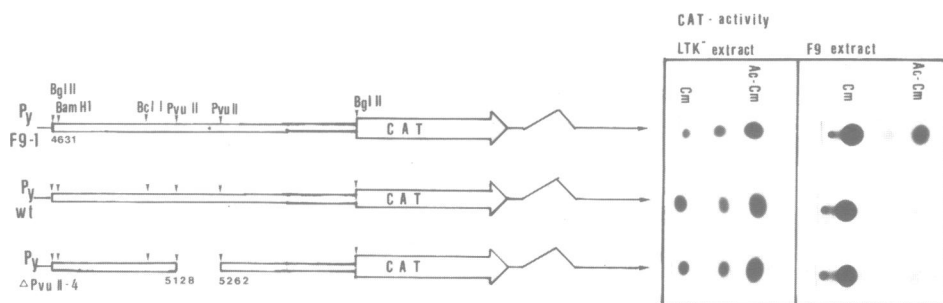

**Fig. 2:** CAT assays of LTK<sup>-</sup> and F9 EC cells. On the left of the figure, the recombinant plasmids used for transfections are schematically represented. On the right side, the autoradiographs are shown whereby chloramphenicol is to the left and its acetylated forms are to the right as indicated (Cm, Ac-Cm). The cellular extracts were prepared as described in materials and methods. CAT assays were performed with 50% of the sonicated extracts, 1  $\mu$ l <sup>14</sup>C-chloramphenicol, 30  $\mu$ l 4mM acetyl-CoA and 100  $\mu$ l 250 mM Tris-HCl pH 7.8 for 1 h at 37°C.

CAT gene under the control of the polyoma early transcriptional elements.

The functional activity of this enhancer/promoter region was tested by transient expression following transfection of the respective plasmid DNA into mouse LTK<sup>-</sup> cells and similarly into F9 stem cells. Two days after transfection, the cells were harvested and extracts were prepared and tested for the presence of CAT activity (22). As demonstrated in Fig. 2, both Py F9-1 and Py wt yield similar levels of CAT activity in LTK<sup>-</sup> cells. However, transfection of F9 cells with PyF9-1 CAT results in at least 8 times more CAT activity as compared to the same cells transfected with Py wt CAT constructions. The enhancement seen in F9 cells is due to the PvuII-4 fragment (#5128-#5262) since its deletion from the Py F9-1 CAT DNA results in a loss of activity. In contrast, LTK<sup>-</sup> cells transfected either with Py wt or this deletion mutant produce similar amounts of CAT enzyme. These results are in good agreement with the data of Herbolmel *et al.* (2) and indicate the presence of two enhancer elements in the polyoma-virus genome. From our results, we conclude that the PvuII-4 fragment that contains the Py enhancer B and the F9-1 specific mutation is essential for activity in F9 stem cells.

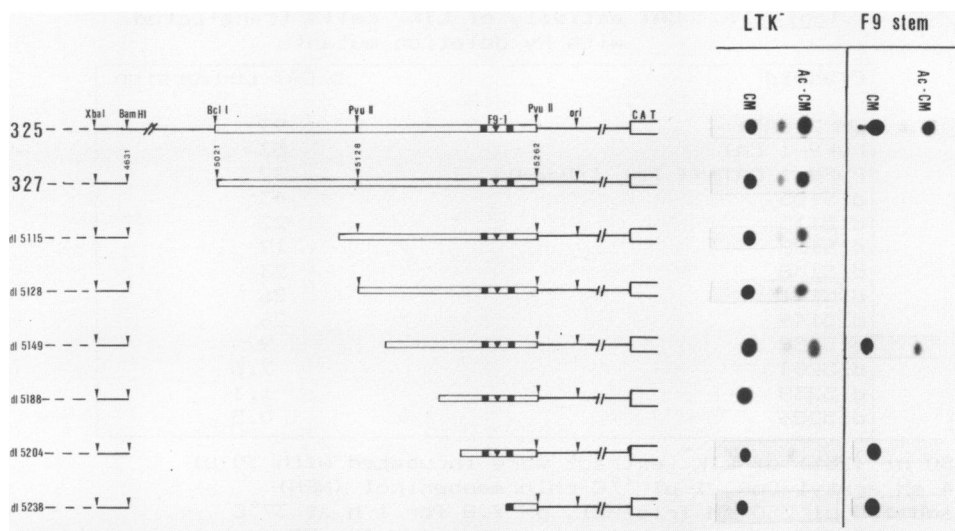

**Fig. 3:** CAT assays of F9 or LTK<sup>-</sup> cells transfected with various Py deletion mutants. On the left of the figure, the endpoints of the deletions are indicated (e.g., dl5115 refers to the first nucleotide retained using the polyoma numbering system of Soeda *et al.* (32)). The autoradiographs of the CAT assays are shown. Chloramphenicol (Cm) is to the left, its acetylated forms (Ac-Cm) are to the right. The filled squares indicate the position of the F9-1 specific mutation. Fifty percent of the extracts were incubated at 37°C in the presence of 1  $\mu$ l <sup>14</sup>C-chloramphenicol, 40  $\mu$ l 4mM acetyl-CoA and 100  $\mu$ l 250mM Tris-HCl pH 7.8. In the case of the LTK<sup>-</sup> extracts, the reaction was stopped after one hour. The F9 extracts were incubated for another 60 minutes after addition of 20  $\mu$ l acetyl-CoA. In the case of the F9 cells only a selection of clones was transfected as indicated.

#### Deletion Analysis of Polyoma F9-1 Enhancer/Promoter Region

In an attempt to define the 5' boundary of the genetic element responsible for the transcriptional activity of Py F9-1 in F9 cells, we generated and studied a series of Bal 31 deletion mutants in the regulatory region of the viral DNA. The clones are depicted in Fig. 3, which also shows the endpoints of the deletions as determined by sequence analysis (25). The numbers given (e.g., dl5115) refer to the first nucleotide retained in each of the deletion mutants using the numbering system of Soeda *et al.* (32). For functional analysis, individual clones were initially transfected into LTK<sup>-</sup> cells and the resulting CAT activities were determined. As shown in Fig. 3 and Table 1, no

**Table 1:** CAT activity of LTK<sup>-</sup> cells transfected with Py deletion mutants

Plasmid	% CAT conversion
pMr2 CAT*	99
PyF9-1 CAT	53
PyF9-1 CAT** ( <u>Bcl</u> I/ <u>Bam</u> H1)	32
d15105	43
d15115	22
d15128	19
d15138	23
d15141	26
d15149	26
d15188	9
d15204	7.5
d15238	1.1
d15286	0.5

50 µl (25%) of LTK<sup>-</sup> extract were incubated with 30 µl 4 mM acetyl-CoA, 1 µl <sup>14</sup>C-chloramphenicol (NEN) and 100 µl 250 mM Tris-HCl, pH 7.8 for 1 h at 37°C

\* pMr2 CAT is a recombinant containing the MSV enhancer upstream of the SV40 enhancer (45)

\*\* In this mutant, the BamH1/Bcl I (#4631-5021) fragment was deleted from PyF9-1 CAT

drastic reduction of CAT activity occurs in cells transfected with deletion mutants lacking sequences upstream of position #5149. Thus, deletion of enhancer A does not result in a marked decrease in the overall gene activity provided that enhancer B is retained. However, deletion of sequences to position #5188 results in a 6-fold drop of CAT activity (compared to PyF9-1 CAT), indicating that the 5' boundary of enhancer B is located between nucleotides #5149 and #5188. Residual CAT activity (15% of PyF9-1 CAT) is detected until sequences between #5204 and #5238 are deleted.

In order to determine if similar results could be obtained in the homologous cellular background, selected clones were transfected into F9 stem cells (Fig. 3, right panel). Although the CAT activities obtained in F9 cells are uniformly lower, those of the deletion mutants follow the pattern described for the LTK<sup>-</sup> cells. The differences in CAT activity of the various deletion mutants after transfection into F9 stem cells is not due to replication (data not shown). In addition, the transfection experiments in F9 cells with the deletion mutants demonstrate that the enhancer A is not necessary for transcriptional activity in F9 stem cells (see d15149).



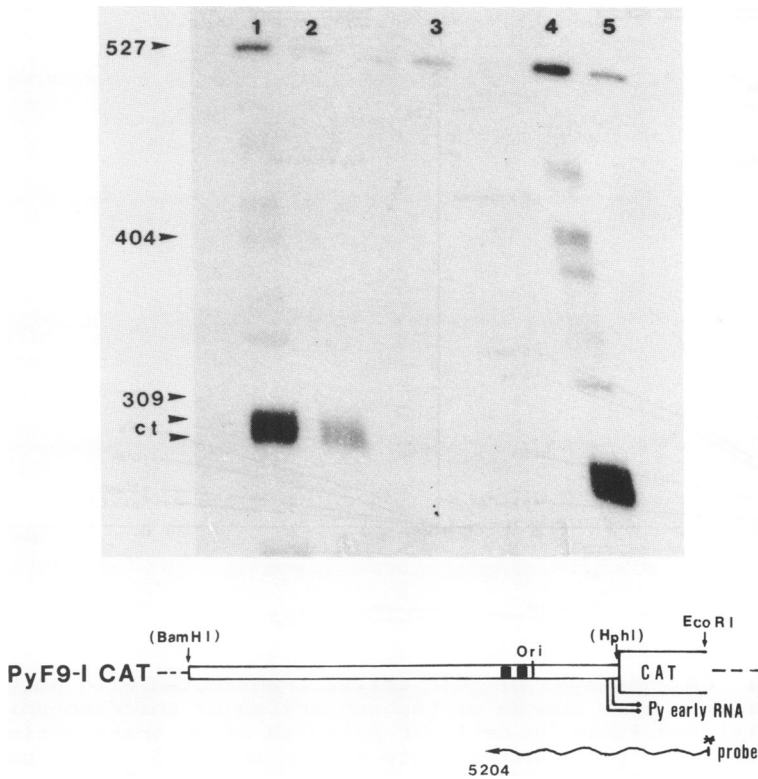

**Fig. 4:** S1 analysis of CAT specific RNAs transcribed from the polyoma early promoter in transfected LTK<sup>-</sup> cells. The Py-CAT construction used for the preparation of the probe is shown at the bottom of the figure. Py early mRNA start sites (31) and the probe used are indicated. The sizes of the protected bands are indicated to the left of the autoradiograph. Lane 1 is obtained after transfection with PyF9-1 CAT, lane 2 with a recombinant in which the Py Bam H1/Bcl I fragment was deleted and lane 4 with MSV dl5204. The authentic polyoma early start sites are indicated with arrows (correct termini, ct). No protected bands of this size were obtained after transfection with the vector CAT3N polylinker (lane 3). The same is true for lane 5 where only the probe was digested with S1 nuclease (Sigma). Although for technical reasons only part of the sample could be loaded in lane 2, the ratio between correct versus incorrect transcripts is nearly the same.

Subsequently, we analyzed RNA from various constructions described in Table 1 in an attempt to demonstrate that the amount of CAT enzyme correlates with the quantity of stable CAT RNA present in transfected cells. Py CAT specific mRNAs were analyzed

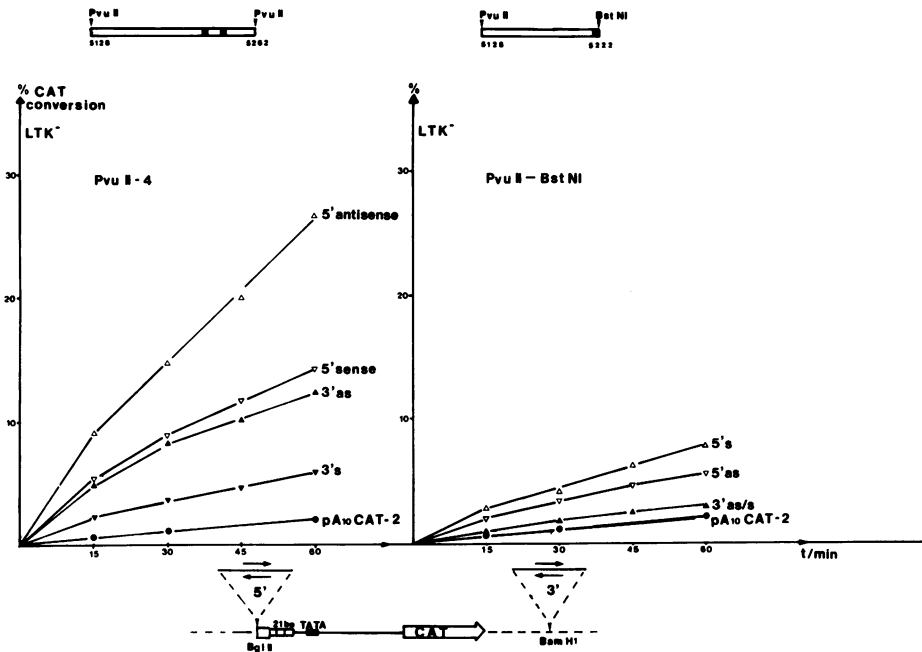
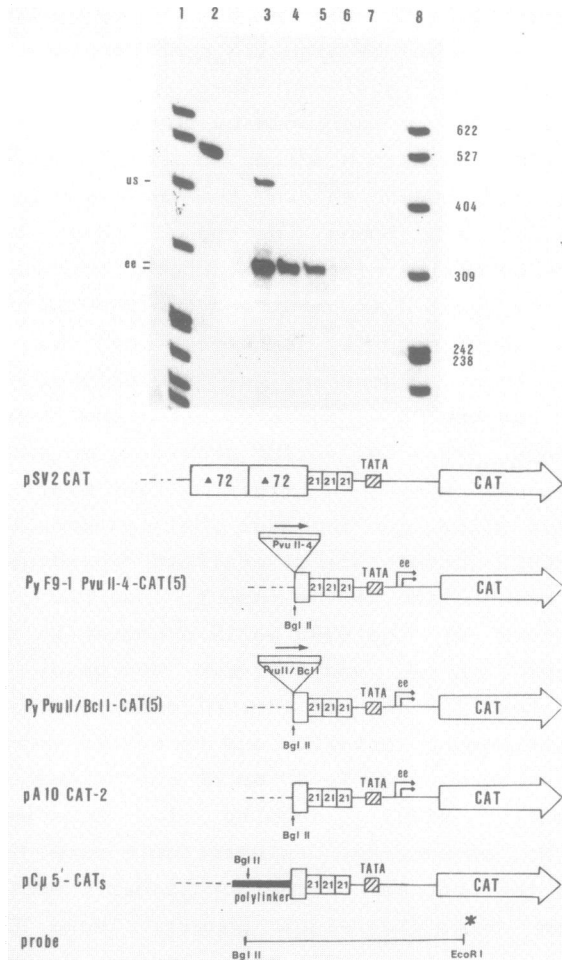

**Fig. 5:** CAT assays of LTK<sup>-</sup> cells transfected with pA10 CAT-2 derivatives. Time course of the conversion of chloramphenicol to its acetylated forms by cellular extracts after transfection with two different polyoma fragments either in the 5' or 3' position with respect to the SV40 early promoter and the CAT gene. Fifty percent of the extracts were incubated with 120  $\mu$ l 250 mM Tris-HCl, pH 7.8, 2.5  $\mu$ l <sup>14</sup>C-chloramphenicol and 30  $\mu$ l 4 mM acetyl-CoA. After various times the reaction was stopped by extraction of aliquots of the mixture with ethylacetate. The ratio of acetylated to unacetylated chloramphenicol were determined and plotted. The left panel shows the results obtained with the PyF9-1 Pvu II-4 fragment after insertion into the vector pA10 CAT-2 (27). CAT activity of pA10 CAT-2 derivatives with insertion of the of the polyoma Pvu II/Bst NI fragment (#5128/#5222) is demonstrated on the right panel.

using S1 nuclease (23) and single stranded probes. The intensity of the protected bands is in good agreement with the CAT data (see Table 1) and, in addition, the Py CAT RNA molecules carry 5' ends similar to those of Py early mRNA (3,31). As shown in Fig. 4, the most abundant transcripts start at the authentic polyoma early start sites (protected bands of 270 and 280 nucleotides, respectively). RNA of untransfected LTK<sup>-</sup> cells (not shown) or fibroblasts transfected with the vector CAT3N polylinker DNA did not yield CAT specific transcripts of this size. The minor

species comigrating with the probe is very likely due to contamination of the probe with its complementary DNA strand as the control lanes (see Fig.4) indicate.

Interestingly and as indicated by the square boxes, two sets of sequences (CCACCC) with homology to the 21-bp repeats of SV40 (see Fig. 7) and sequences in the SV40 and papilloma virus enhancers (33,34) are found in the 3' part of the PvuII-4 fragment. After detection of this structural homology between the 3' part of the PvuII-4 fragment and the SV40 21-bp repeats and since enhancer and promoter sequences can be juxtaposed, a definition of the 3' boundary of the polyoma enhancer B was attempted by subcloning fragments with the same 5' ends but different 3' ends into a CAT vector providing an enhancer-responsive promoter. As shown in Fig. 5 (left panel), the PvuII-4 fragment (#5128-#5262) can increase the transcriptional activity of the pA10-CAT2 vector (35) severalfold depending on the position and the orientation of the insert. Insertion of the PvuII-4 fragment upstream of the SV40 early promoter in sense or antisense resulted in 7- and 13-fold increases respectively. Insertion at the 3' end of the CAT gene results in a sixfold increase in antisense orientation and threefold increase in sense orientation. Absence of only 40 bp at the 3' end of the PvuII-4 fragment (position #5222) results in a drastic drop in enhancement. No enhancement was detectable exceeding a factor 3 to 4 in either the upstream or the downstream position regardless of orientation (Fig. 5, right panel). These CAT data were supported by S1 nuclease 5' end mapping experiments which demonstrate that the various CAT recombinants using the SV40 early promoter initiate their transcripts at the authentic start sites (Fig. 6). In order to rule out that these results are applicable for SV40 promoter sequences only, the PvuII-4 or the PvuII/BstN1 fragment was inserted into a TK-CAT plasmid (36). Insertion of the polyoma PvuII-4 fragment in the downstream position of the CAT gene results in a 40-fold increase of CAT activity after transfection of NIH3T3 cells, whereas the PvuII/BstN1 fragment (#5128-#5222) did not reveal any enhancement effect (Table 2). The results of our experiments indicate that polyoma F9-1 enhancer B sequences are contained between nucleotides #5149 and #5262.



**Fig. 6:** Mapping of 5' ends of CAT -RNAs in LTK<sup>-</sup> cells transfected with pA10 CAT-2 derivatives. Cytoplasmic RNA from two 10 cm dishes of LTK<sup>-</sup> cells transfected with pSV2 CAT (lane 4), PyF9-1 PvuII-4 CAT (5') (lane 5), Py PvuII/Bcl I CAT (5') (lane 6) or pA10 CAT-2 (lane 7) were hybridised with a <sup>32</sup>P labelled single stranded DNA probe (Bgl II/Eco RI fragment of pCu5' CAT (30), lane 2) and treated with S1 nuclease (Sigma). Lane 3 demonstrates the 5' ends of 50  $\mu$ g total RNA of LTK<sup>-</sup> cells after transfection with pSV2 CAT. Transcripts that originate from the early SV40 viral start sites were protected to a length of 320 nucleotides (lane 3 to 6). PyF9-1 PvuII-4 CAT (5') and Py PvuII/Bcl I CAT (5') are recombinants that result after insertion of the respective restriction fragments in sense orientation at the Bgl II site of pA10 CAT-2. Size markers (lane 1 and 8) are fragments produced by HpaII digestion of pBR 322. The structures of the transfected DNAs and the probe are shown schematically at the bottom of the figure.

**Table 2:** CAT activities of NIH3T3 cells transfected with TK-CAT constructions

Plasmid	% CAT conversion
pMr2 CAT	47.0
PyF9-1 CAT	37.5
pTK CAT	0.9
pTK CAT(PyF9-1 <u>PvuII</u> -4)*	35.0
pTK CAT(Py <u>PvuII</u> / <u>BstN1</u> )**	0.8

100  $\mu$ l (50%) of the NIH3T3 extract were incubated with 30  $\mu$ l 4 mM acetyl-CoA, 1  $\mu$ l  $^{14}$ C-chloramphenicol (NEN) and 100  $\mu$ l 250 mM Tris-HCl, pH 7.8 for 1 h at 37°C.

\* The recombinant pTK CAT(PyF9-1 PvuII-4) has a 3' insertion of the F9-1 PvuII-4 fragment in a plasmid derived from pTK CAT(36)

\*\* The recombinant is analogous to pTK CAT(PyF9-1 PvuII-4) but the polyoma PvuII/BstN1 fragment was inserted downstream of the CAT gene.

#### Enhancers Require Polyoma F9-1 Promoter Elements or Functionally Equivalent Sequences for Their Activity in F9 and LTK<sup>-</sup> Cells

Having characterized the boundaries of enhancer B, we sought to define further the polyoma F9-1 sequences required for activity of heterologous enhancers in F9 and LTK<sup>-</sup> cells. It has been shown in the SV40 system that the 21-bp repeats are essential promoter elements (37,38,39) and that at least one intact copy of the 21-bp repeats is required for functional activity (40,41). It was therefore of interest to determine whether an element similar in function is present in the polyoma virus genome. To our surprise, sequence comparison between the SV40 noncoding region and the transcriptional control region of polyoma F9-1 revealed a stretch of sequence with striking homology (Fig. 7, top) to the 21-bp repeats. As shown by the deletion analysis, this sequence is an essential part of enhancer B and is located in the 3' portion of this enhancer element. Furthermore, the importance of a sequence motif (CCACCC) in the 3' part of the polyoma enhancer was indicated by previous sequence comparisons (33). Because of the structural homology of the mutated 3' part of the Py enhancer B and the SV40 21-bp repeats we were interested in determining whether this part of the enhancer would function in a way analogous to the SV40 21-bp repeats as a promoter element in fibroblasts and F9 stem cells. Therefore the SV40 (PvuII/NcoI) and the MSV (72-bp PvuII fragment of LTR, ends

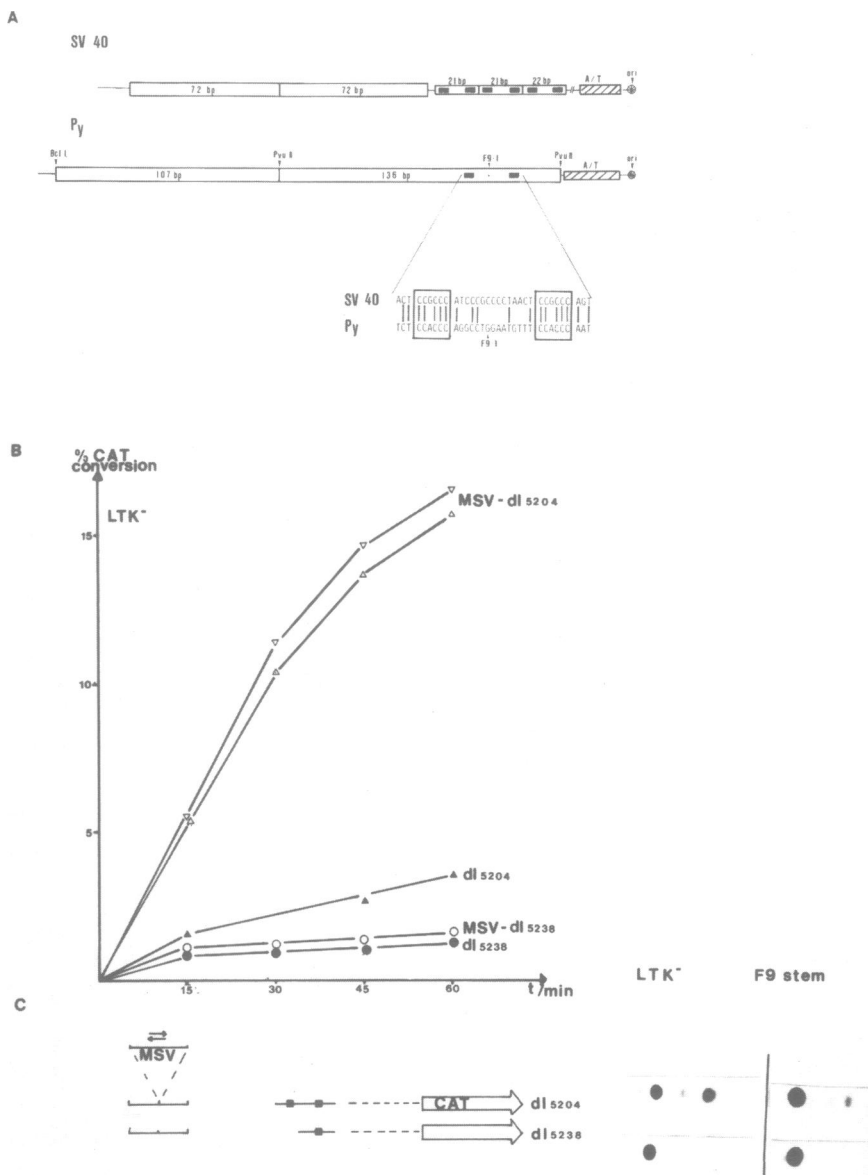

**Fig. 7:** A: Sequence homology between the SV40 and the polyoma genome. Comparison of sequences in the noncoding regions of SV40 and polyoma viruses showed an interesting sequence homology. Matching the PvuII site (#5128) to the border of the SV40 72-bp repeats the first of the SV40 repeats is in a comparable position to the polyoma enhancer A which is located in the 3' part of the Bcl I/PvuII (#5021/#5128) fragment (2). The second 72-bp repeat is in a location similar to the polyoma enhancer B that is

---

contained on the PvuII-4 (#5128/#5262) fragment (1,2). In addition, CCACCC motifs that were described earlier as part of the BPV enhancer (33,34) are at a distance and in a conserved spatial arrangement comparable to that of the SV40 CCGCC elements to the 72-bp repeats.

B: Expression of CAT activity in LTK<sup>-</sup> cells transfected with two different Bal 31 deletion mutants which have an insertion of a MSV enhancer. Forty percent of the extract were incubated with 40  $\mu$ l 4mM acetyl-CoA, 2  $\mu$ l <sup>14</sup>C-chloramphenicol and 100  $\mu$ l 250mM Tris-HCl pH 7.8. At the indicated time points aliquots of the reaction mixture were stopped and analysed on thin layer chromatography. The spots were then counted in a liquid scintillation counter and plotted. The MSV sequence used as enhancer element is a 72 bp PvuII fragment of the LTR (ends changed to XbaI). Due to the fluctuation of results obtained in this assay system two independently isolated clones of MSV-d15204 were tested.

C: In addition to the results outlined in Fig. 7B that were obtained using LTK<sup>-</sup> extracts we could also demonstrate that this MSV enhancer fragment can activate d15204 in F9 stem cells. CAT assays on the F9 extracts were done according to the procedure described in legend to Fig. 3.

converted to XbaI) enhancers were inserted in sense orientation upstream of the Bal 31 deletion mutant d15204. Both enhancer elements could stimulate the expression of the CAT gene in fibroblasts approximately 6- (MSV) or 10- (SV40) fold (see Fig. 7B, SV40 data not shown). Although the overall transcriptional activity is lower in EC cells (see Table 3), the same is true for F9 transfection experiments. In the case of the MSV enhancer we also tested the deletion mutant d15238 which lacks one of the CCACCC motifs and the F9-1 point mutation. Insertion of the MSV enhancer into d15238 at the same position and orientation as in d15204 did not enable this mutant to induce the production of CAT activity in fibroblasts or in F9 cells (see Fig.7B), suggesting that the 3' part of the PyF9-1 enhancer B may also serve as an upstream promoter element.

## DISCUSSION

Polyoma virus variants selected for growth in F9 teratocarcinoma cells carry mutation(s) within the enhancer/promoter region (12-17). Of particular interest was the functional analysis of the polyoma F9-1 mutant that carries a single point mutation in the sequence of Py wild-type strain A3 (18). Initially, we approached the analysis of this mutant by deletion mutagenesis. CAT conversion as an indirect measure of

**Table 3:** CAT activities of F9 cells transfected with deletion mutants

Plasmid	% CAT conversion
PyF9-1 CAT	18.0
d15128	8.0
d15204	0.5
d15238	0.3
MSV d15204	3.0
MSV d15238	0.3

100  $\mu$ l (50%) of F9 extracts were incubated with 40  $\mu$ l 4 mM acetyl-CoA, 2  $\mu$ l  $^{14}$ C-chloramphenicol (NEN) and 100  $\mu$ l 250 mM Tris-HCl, pH 7.8 for 1 h at 37°C. Another 20  $\mu$ l of 4 mM acetyl-CoA were added and the reaction was incubated for additional 60 minutes.

transcriptional activity and the amount of RNA produced by individual deletion mutants after transfection in mouse fibroblasts and F9 stem cells were determined. Our results indicate that no drastic decrease in overall CAT activity is observed in fibroblasts if either enhancer A or B is deleted. Since in the case of polyoma virus the transcriptional enhancer is necessary in cis for replication (42) these results are in good agreement with previous studies focussing on elements required for replication in MOP 8 cells (6,7) and COP-5 cells (48). These experiments defined two domains ( $\alpha$ ,  $\beta$ ) both of which function in conjunction with a replicational "core" element. Both domains are located in the region harboring the transcriptional enhancer elements A and B (1,2). Analyses of the deletion mutants indicate that the first reduction in transcriptional activity occurred in cells transfected with mutants lacking sequences upstream of position #5188. Thus, the 5' boundary of the polyoma B enhancer must be located between nucleotides #5149 and #5188 (see Fig. 3). In order to define the 3' boundary of enhancer B, we cloned different fragments containing the putative enhancer region (1,2,4) into vectors carrying enhancer responsive promoter elements followed by a test gene (CAT). Two such enhancer responsive vectors were utilized. The first provided SV40 sequences required for the mediation of enhancer activity (21-bp repeats, TATA box (35)), the second plasmid carried the HSV-TK promoter (43) preceding the CAT test gene (36). Both plasmids yielded essentially identical results, although the SV40 promoter



---

shows a higher basal activity in the absence of any enhancer sequences in mouse LTK<sup>-</sup> cells when compared with the TK promoter. We found, in agreement with previous studies (1,2), that the PvuII-4 fragment (#5128-#5262) which includes the point mutation of F9-1 is sufficient to provide enhancer activity. On the other hand, deletion of only 40 nucleotides at the 3' end of this fragment (PvuII/BstNI) decreased the enhancement effect on both promoters examined. Interestingly, the deletion removed the point mutation of F9-1 and one copy of the consensus sequence CCACCC which was previously identified by sequence comparison (33) and is known to play a critical role in the enhancer of papilloma virus (34). Thus, the 3' sequence boundary of enhancer B must lie between nucleotides #5222 and #5262.

In contrast to published results (2), we detected by S1 mapping analysis that enhancer B is more active than enhancer A on the SV40 early promoter (see Fig. 6). In addition using our viral deletion mutants we could not detect the reported superiority of enhancer A over enhancer B (Table 1 and Fig. 3) with respect to the Py early promoter in mouse fibroblast cells. In summary we conclude that although there are some differences between the Py enhancers A and B on heterologous promoter elements (2 and our own results) these two enhancer elements are functionally equivalent on the Py early promoter in mouse fibroblast cells. With respect to F9 stem cells our data suggest that the PvuII-4 fragment containing the Py B enhancer and the F9-1 specific mutation is essential for early gene expression in F9 stem cells whereas the enhancer A is dispensable for this function (see Fig. 2 and 3). Therefore the Py mutant F9-1 contains two enhancer elements with different tissue specificities.

In addition to the partial sequence homology to the papilloma virus enhancer our sequence comparison revealed an interesting homology to the SV40 21-bp repeats. On the basis of this homology, we were interested to determine whether this sequence could be activated similarly to the SV40 21-bp repeats by heterologous enhancer elements. Thus, we used in our experimental approach two of the deletion mutants (d15204 and d15238) as recipients for the insertion of two different

---

enhancers. The deletion mutants were identical except that the first one retained both CCACCC elements and the F9-1 mutation whereas the second one lacked the mutation and one of the motifs. Insertion of either the SV40 (37,44) (data not shown) or the MSV enhancer (45) revealed that mutant d15204 responded with a 12-fold higher activity upon transfection into LTK<sup>-</sup> cells. Insertion of the MSV enhancer into the deletion mutant d15238, however, did not yield any increase in CAT gene activity in either orientation. We therefore conclude that the two CCACCC motifs can serve a dual function. On the one hand, they are part of the polyoma B enhancer and, on the other, analogous to the SV40 21-bp repeats they are an integral part of an upstream promoter element that can be activated by the MSV and SV40 enhancer. These data are in good agreement with results obtained by Veldman *et al.* (48) where the 3' border of the Py B enhancer was mapped between nucleotides #5214 and #5179 thereby excluding the point mutation at nucleotide #5230. The discrepancy with our 3' mapping experiments could be due to the fact that we subcloned different fragments in front of heterologous promoter elements whereas Veldman and collaborators made a Bal 31 deletion series starting at the origin proximal PvuII site (#5262). Furthermore the presence of A enhancer sequences in their deletion mutants may contribute to the discrepancy. Another explanation might be that we were measuring transcriptional activity whereas they used a replicational assay in COP-5 cells. The fact that the mutant which has a deletion of the PvuII-4 fragment is transcriptionally active in LTK<sup>-</sup> cells seems to be contradictory to the promoter hypothesis. One possible explanation for this discrepancy might be that there are another 180 bp of the early promoter retained that might contain cryptic promoter elements which are activated in the absence of the PvuII-4 fragment. Although there are some other CCACCC motifs present in the Py genome between the origin of replication and the major start sites of the early transcriptional unit, further mapping experiments are required to determine the promoter used. In the case of polyoma this enhancer/promoter element seems to be necessary for replication (42). Our own data and the results of other groups (1,2,4,5,6,7,48) indicate that the PvuII-4 fragment harbors

elements with overlapping functions whereby the different functions might have different sequence requirements.

The activation of d15204 by insertion of the MSV enhancer fragment in F9 cells is noteworthy because it was previously reported (46) that the MSV retroviral LTR was nonfunctional in F9 stem cells. One possible explanation for this apparent contradiction would be that other retroviral sequences outside the MSV enhancer might have an inhibitory effect on the transcription in EC cells. The enhancement of the Py promoter by the MSV 72-bp sequence could result from two different mechanisms. First, insertion of the MSV enhancer fragment reconstituted an active enhancer element, which consists of the MSV fragment and the 3' part of polyoma enhancer B. This would be in good agreement with the observation that the SV40 enhancer as prototype for DNA viral enhancers contains two binding domains (A. Wildemann, P. Chambon, personal communication). Such reconstitution of an enhancer by two independent domains is expected to be reliant upon the spatial arrangement between the two elements. However, as activation of d15204 resulted from two different enhancer elements and, in the case of SV40, even in both orientations we consider this explanation to be very unlikely. The second possibility is that the MSV fragment used in these studies is active as an enhancer in F9 stem cells and that d15204 provides an intact promoter element.

In order to explain the F9-1 specific transcriptional effect it is reasonable to speculate that the alteration allows specific binding of transcription factors present in stem cells. Alternatively, polyoma wild-type could be repressed in EC cells by negative control factors which bind less efficiently to mutated regulatory sequences. In this model the negative controlling factor(s) would be removed during differentiation. Our current research is directed towards an understanding of the factors involved in polyoma early gene expression in F9 cells.

#### ACKNOWLEDGEMENTS

The authors wish to thank M. Botchan, A. Colberg-Poley, M. Kessel and S. Voss for discussions. We also thank R. Franklin for help in the preparation of the manuscript. K. Chowdhury was

supported by the Bundesministerium für Forschung und Technologie (BCT 0364/1). This research was supported by the Deutsche Forschungsgemeinschaft (Ba 384/18-4).

REFERENCES

1. Linney, E. and Donerly, S. (1983) *Cell* 35, 693-699.
2. Herbomel, P., Bourachot, B. and Yaniv, M. (1984) *Cell* 39, 653-662.
3. Tooze, J. (ed.) (1981), *Tumor Viruses*, CSH.
4. de Villiers, J. and Schaffner, W. (1981) *Nucl. Acids. Res.* 9(23), 6251-6264.
5. Tyndall, C., La Mantia, G., Favoloro, J. and Kamen, R. (1981) *Nucl. Acids Res.* 9(23), 6231-6250.
6. Mueller, C.R., Mes-Masson, A., Bouvier, M. and Hassell, J.A. (1984) *Mol. Cell. Biol.* 4(12), 2594-2609.
7. Muller, W.J., Mueller, C.R., Mes, A. and Hassell J.A. (1983) *J. Virol.* 47, 586-599.
8. Kurkinen, M., Barlow, D.B., Helfman, D.M., Williams, J.G. and Hogan, B.L.M. (1983) *Nucl. Acids Res.* 11(18), 6199-6209.
9. Tabor, J.M. and Oshima, R.G. (1982) *J. Biol. Chem.* 257, 8771-8774.
10. Martin, G.R. (1980) *Science* 209, 768-776.
11. Silver, L.M., Martin, G.R. and Strickland, S. (1983) *Teratocarcinoma Stem Cells*, Vol. 10, CSH.
12. Katinka, M., Vasseur, M., Montreau, N., Yaniv, M. and Blangy, D. (1981) *Nature* 290, 720-722.
13. Katinka, M., Yaniv, M., Vasseur, M. and Blangy, D. (1980) *Cell* 20, 393-399.
14. Sekikawa, K. and Levine A.J. (1981) *Proc. Natl. Acad. Sci. USA* 78(2), 1100-1104.
15. Vasseur, M., Katinka, M., Herbomel, P., Yaniv, M. and Blangy, D. (1982) *J. Virol.* 43(3), 800-808.
16. Fujimura, F.K., Deininger, P.L., Friedmann, T. and Linney, E. (1981) *Cell* 23, 809-814.
17. Tanaka, K., Chowdhury, K., Chang, K.S.S., Israel, M. and Ito, Y. (1982) *EMBO J.* 1(12), 1521-1527.
18. Deininger, P.L., Esty, A., LaPorte, P., Hsu, H. and Friedmann, T. (1980) *Nucl. Acids Res.* 8, 1855-1860.
19. McCutchan, J.H. and Pagano, J.S. (1965) *J. Natl. Cancer Inst.* 41, 351-357.
20. Graham, F.L. and van der Eb, A.J. (1973) *Virology* 52, 456-457.
21. Gorman, C.M., Moffat, L.F. and Howard, B.H. (1982) *Mol. Cell. Biol.* 2, 1044-1051.
22. Schöler, H.R. and Gruss, P. (1984) *Cell* 36, 403-411.
23. Maniatis, T., Fritsch, E.F. and Sambrook, J. (1982), *Molecular Cloning, A Laboratory Manual*, CSH.
24. Hutchison, K.W. and Halvorson, H.O. (1980) *Gene* 8, 267-278.
25. Maxam, A. and Gilbert, W. (1977) *Proc. Natl. Acad. Sci. USA* 74, 560-564.
26. Chirgwin, J.M., Przybyla, A.E., MacDonald, R.J. and Rutter, W.J. (1979) *Biochemistry* 18, 5294-5299.
27. Laimins, L.A., Khoury, G., Gorman, C., Howard, B. and Gruss, P. (1982) *Proc. Natl. Acad. Sci. USA* 79, 6453-6457.
28. Walker, M.D., Edlunt, T., Boulet, A.M. and Rutter, W.J. (1983) *Nature* 306, 557-561.

29. Kenney, S., Natarajan, V., Strike, D., Khoury, G. and Salzman, N.P. (1984) *Science* 226, 1337-1339.
30. Mosthaf, L., Pawlita, M. and Gruss, P. (submitted)
31. Kamen, R., Jat, P., Treisman, R. and Favaloro, J. (1982) *J. Mol. Biol.* 159, 189-224.
32. Soeda, E., Arrand, J.R., Smolar, N., Walsh, J.E. and Griffin, B.E. (1980) *Nature* 283, 445-453.
33. Lusky, M., Berg, L., Weiher, H. and Botchan, M. (1983) *Mol. Cell. Biol.* 3(6), 1108-1122.
34. Weiher, H. and Botchan, M. (1984) *Nucl. Acids Res.* 12, 2911-2916.
35. Laimins, L.A., Gruss, P., Pozzati, R. and Khoury, G. (1984) *J. Virol.* 49, 183-189.
36. Gorman, C., Laimins, L.A., Merlino, G.T., Gruss, P., Khoury, G. and Howard, B. (1984) in *Eucaryotic Gene Expression*, Kumar, A. ed., Plenum Publishing Corporation.
37. Benoist, C. and Chambon, P. (1981) *Nature* 290, 304-310.
38. Fromm, M. and Berg, P. (1982) *J. Mol. Appl. Genet.* 1, 457-481.
39. Vigneron, M., Barrera-Saldana, H.A., Baty, D., Everett, R.D. and Chambon, P. (1984) *EMBO J.* 3(10), 2373-2382.
40. Everett, R.D., Baty, D. and Chambon, P. (1983) *Nucl. Acids Res.* 11(8), 2447-2464.
41. Baty, D., Barrera-Saldana, H.A., Everett, R.D., Vigneron, M. and Chambon, P. (1984) *Nucl. Acids Res.* 12, 915-932.
42. de Villiers, J., Schaffner, W., Tyndall, C., Lupton, S. and Kamen R. (1984) *Nature* 312, 242-246.
43. Mc Knight, S.L. and Kingsbury R. (1982) *Science* 217, 316-326.
44. Gruss, P., Dhar, R. and Khoury, G. (1981) *Proc. Natl. Acad. Sci. USA* 78, 943-947.
45. Levinson, B., Khoury, G., Vande Woude, G. and Gruss, P. (1982) *Nature* 295, 568-572.
46. Linney, E., Davis, B., Overhauser, J., Chao, E. and Hung, F. (1984) *Nature* 308, 470-472.
47. Lusky, M. and Botchan, M. (1981) *Nature* 293, 79-81.
48. Veldman, G.M., Lupton, S. and Kamen R. (1985) *Mol. Cell. Biol.* 5(4), 649-658