Online Supplementary Material:

(A) Linkage Map (Fig. 3)

(B) SM Analysis (Fig. 4)

(C) IM Analysis (R/QTL) (Fig. 5)

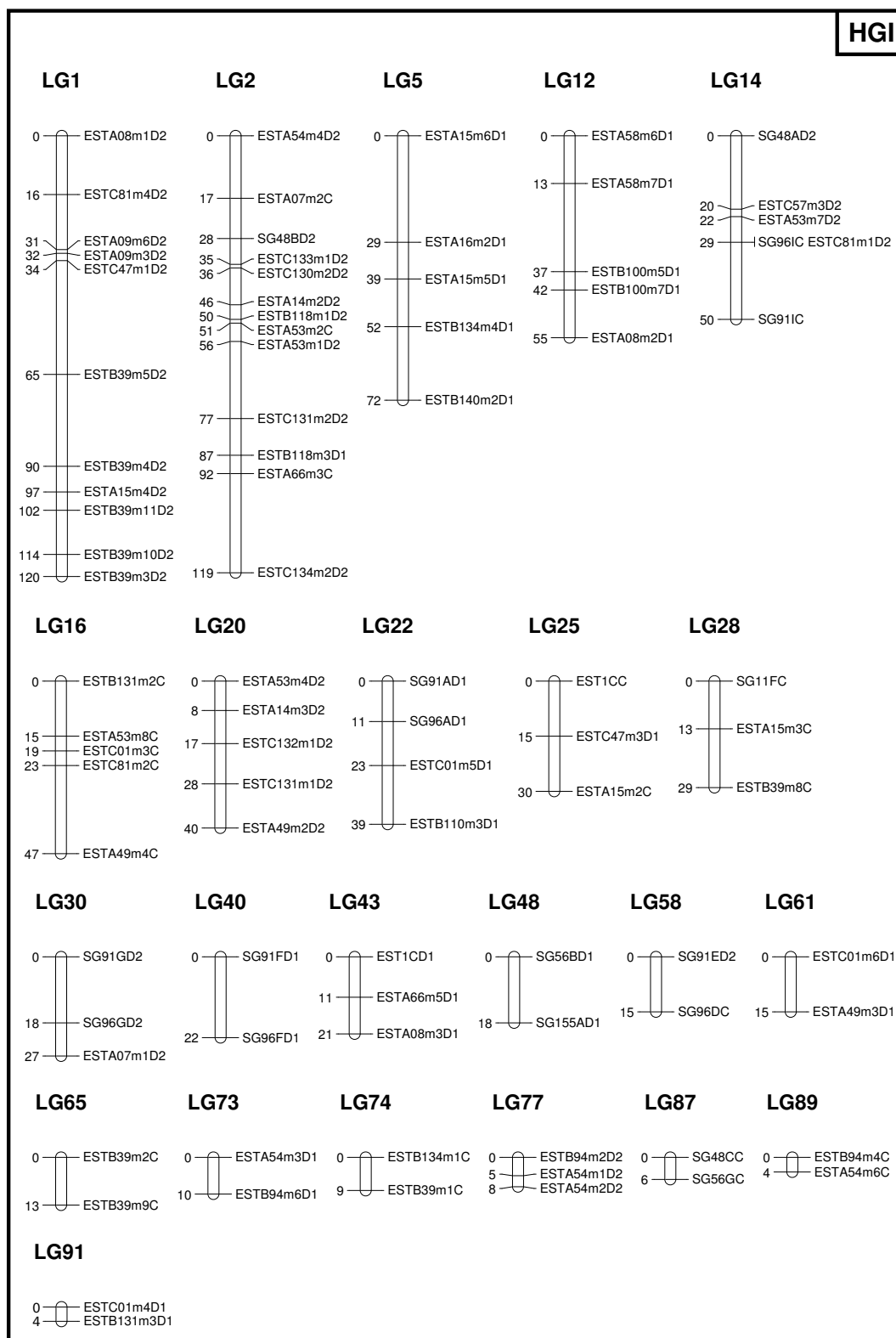

Fig. 3 Integrated genetic map of a sugarcane commercial cross (SP80-180 × SP80-4966) based on 100 individuals. Map distances are given in centimorgans (Kosambi). LG: linkage group. HG: homology group.

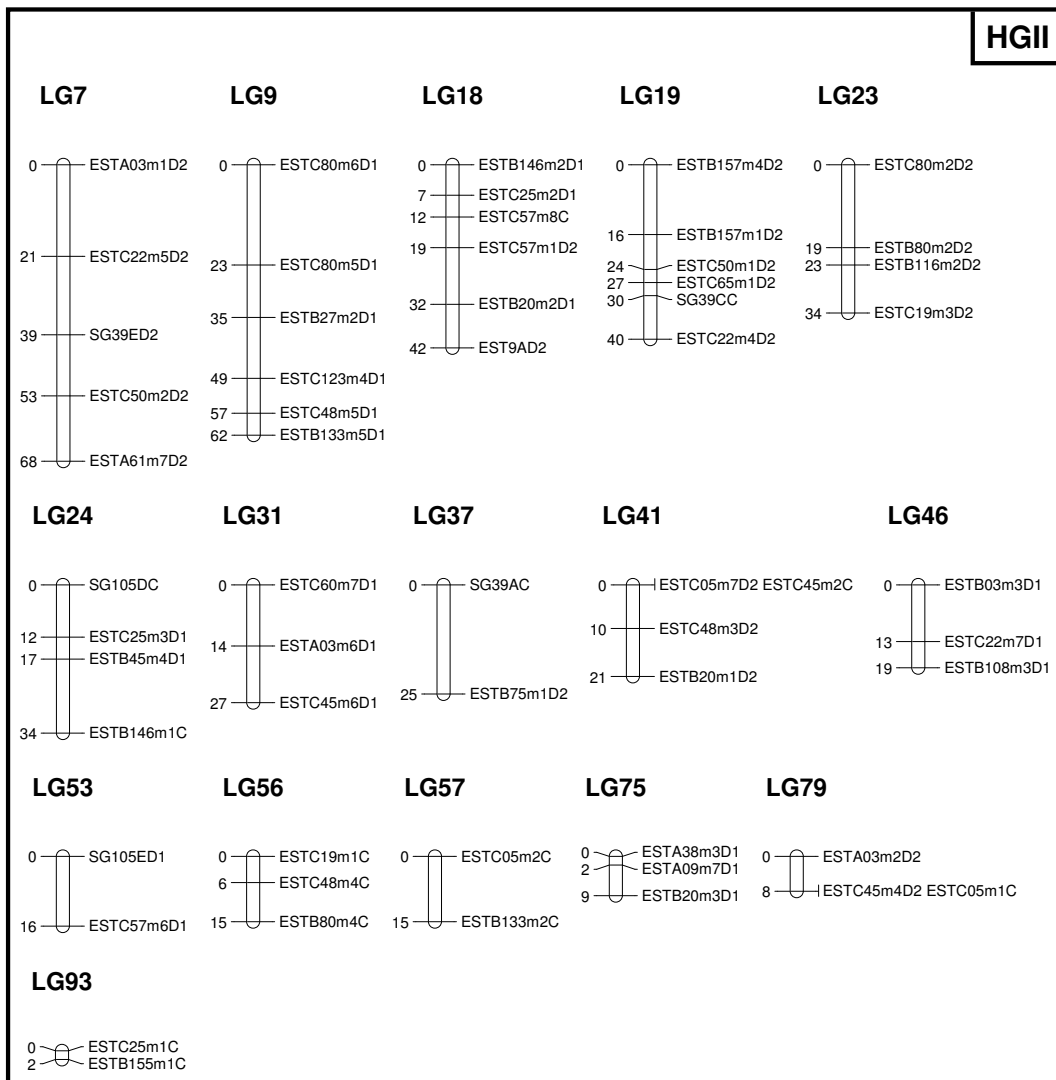

Fig. 3 (Contd.)

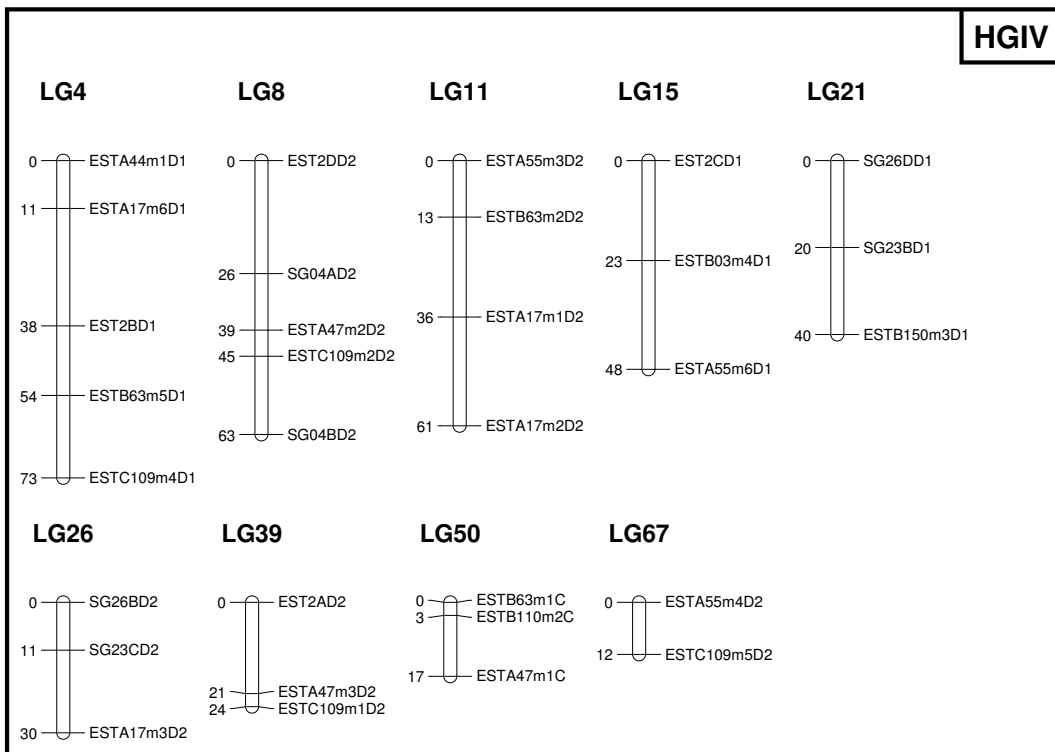
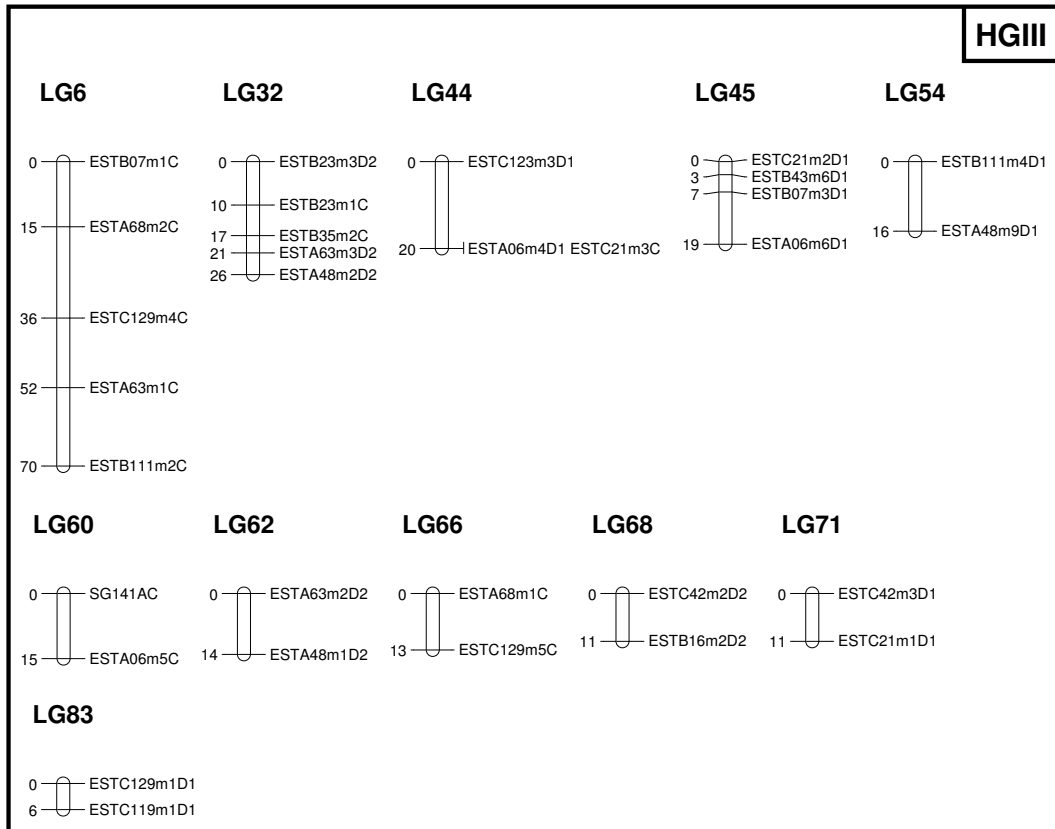

Fig. 3 (Contd.)

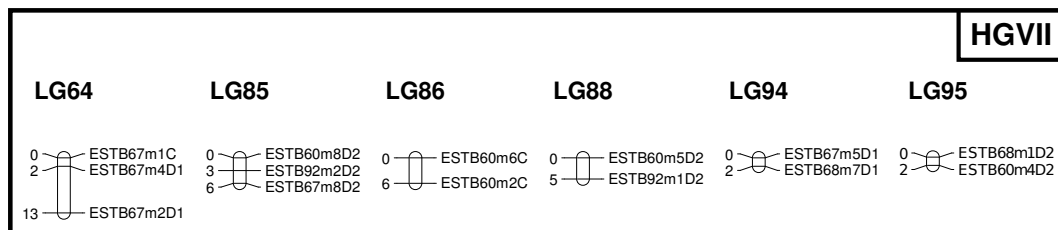
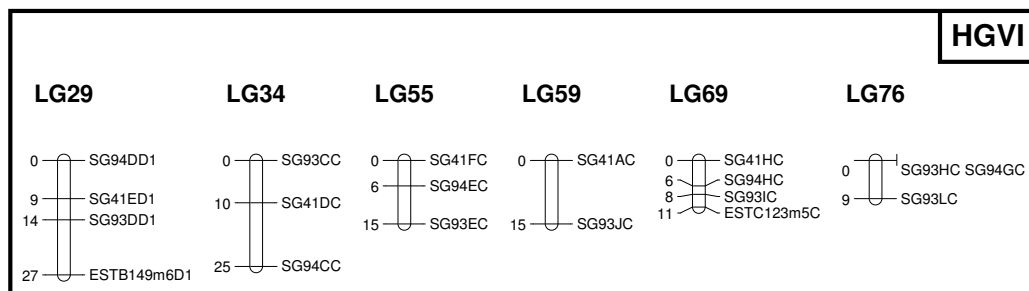
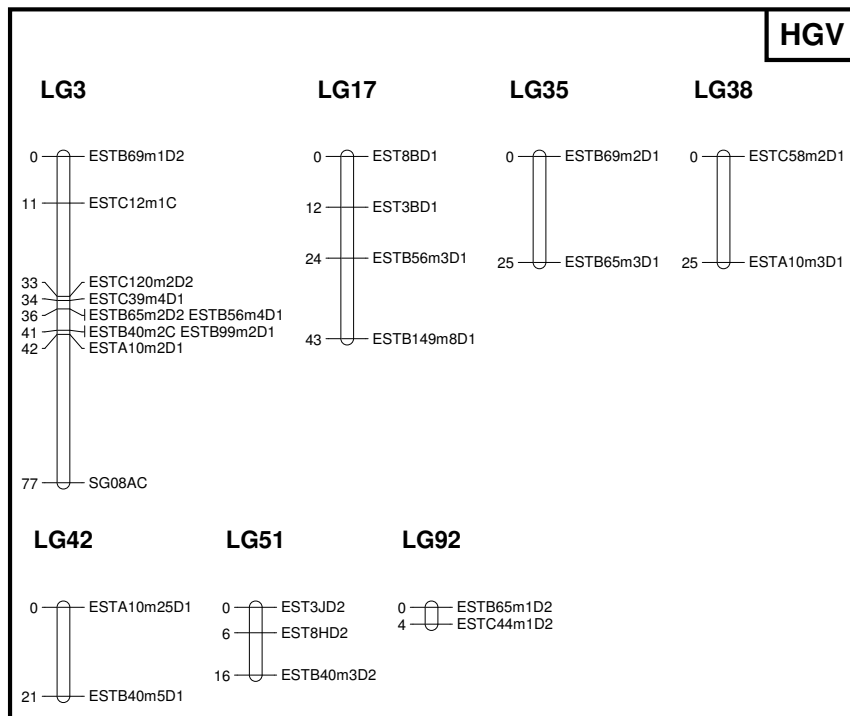

Fig. 3 (Contd.)

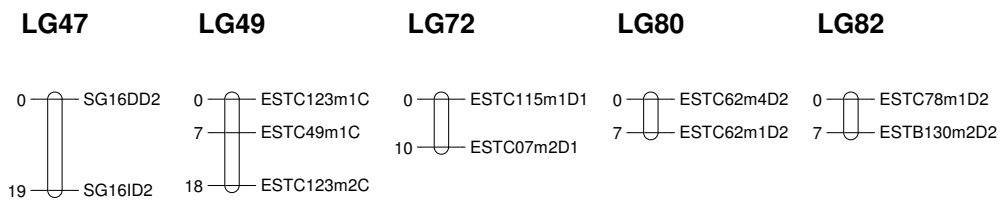
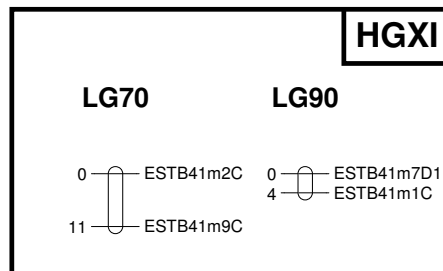
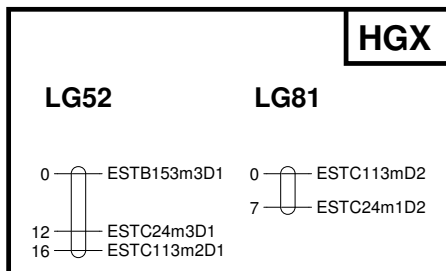
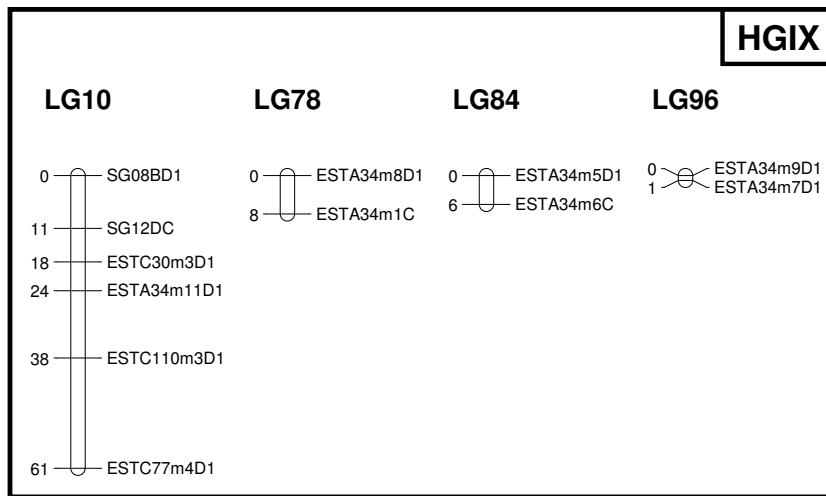
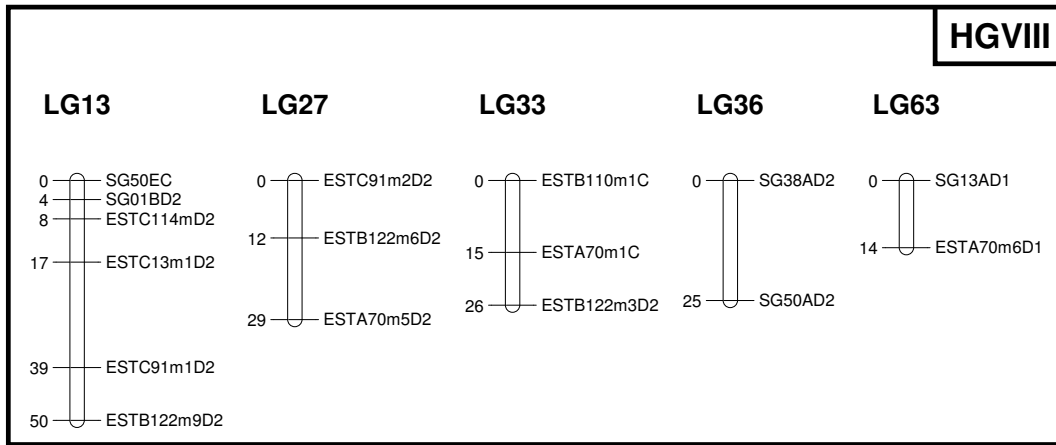

Fig. 3 (Contd.)

4

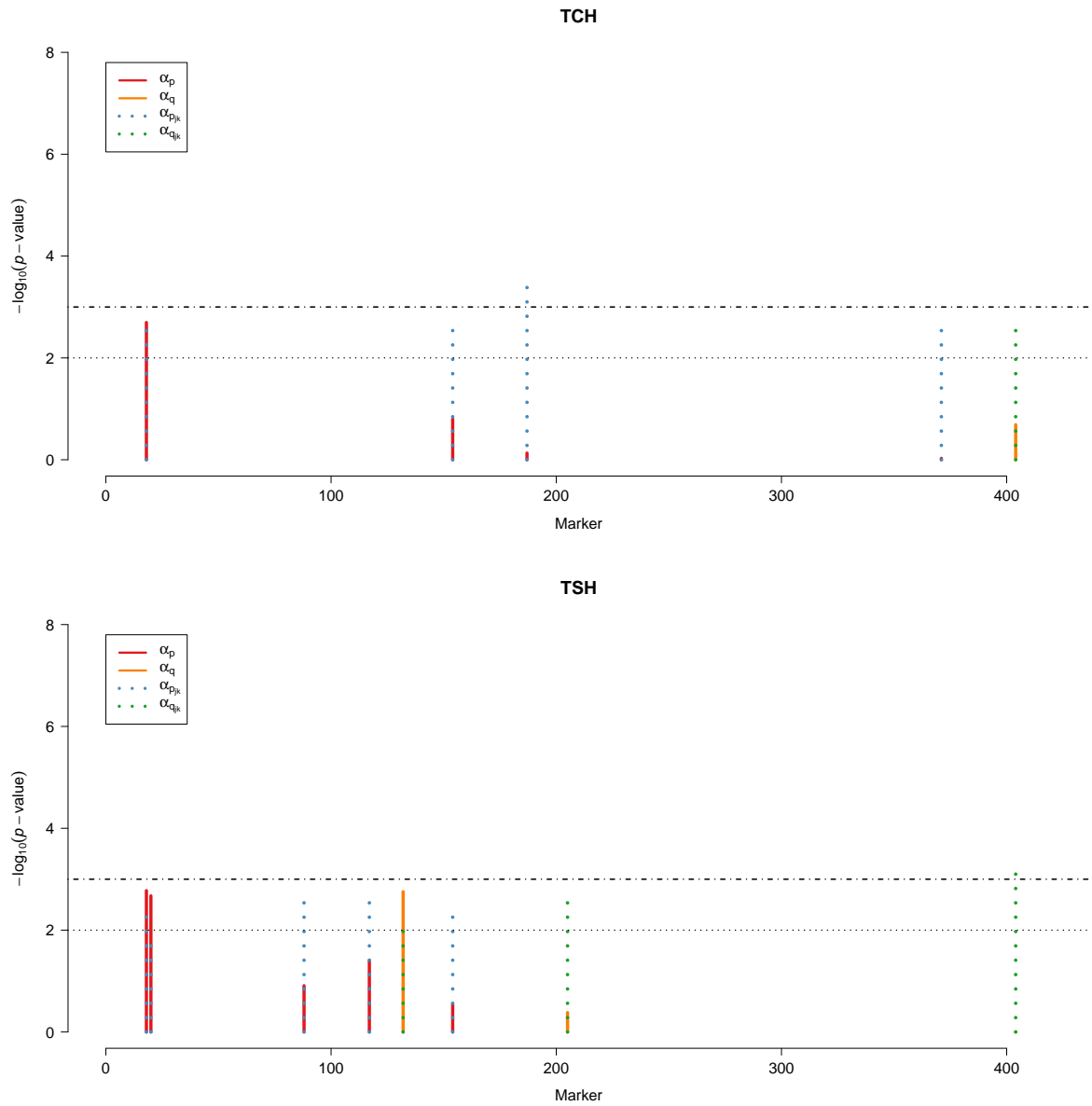

Fig. 4 Putative QTL associated with cane yield (tonnes of cane per hectare, TCH), sugar yield (tonnes of sugar per hectare, TSH), fiber content and sucrose content (Pol) using a mixed model with unstructured \mathbf{G}_M matrix (model e; Table 2) via SM analysis. Two different situations were considered: 1) using only main effects, model 5 (α_p and α_q for additive effects on parents P and Q , respectively); 2) using genetic effects specifically for each harvest-location combination, model 4 ($\alpha_{p_{jk}}$ and $\alpha_{q_{jk}}$). Dot-dashed line: $-\log_{10}(0.001)$ and dotted line: $-\log_{10}(0.01)$.

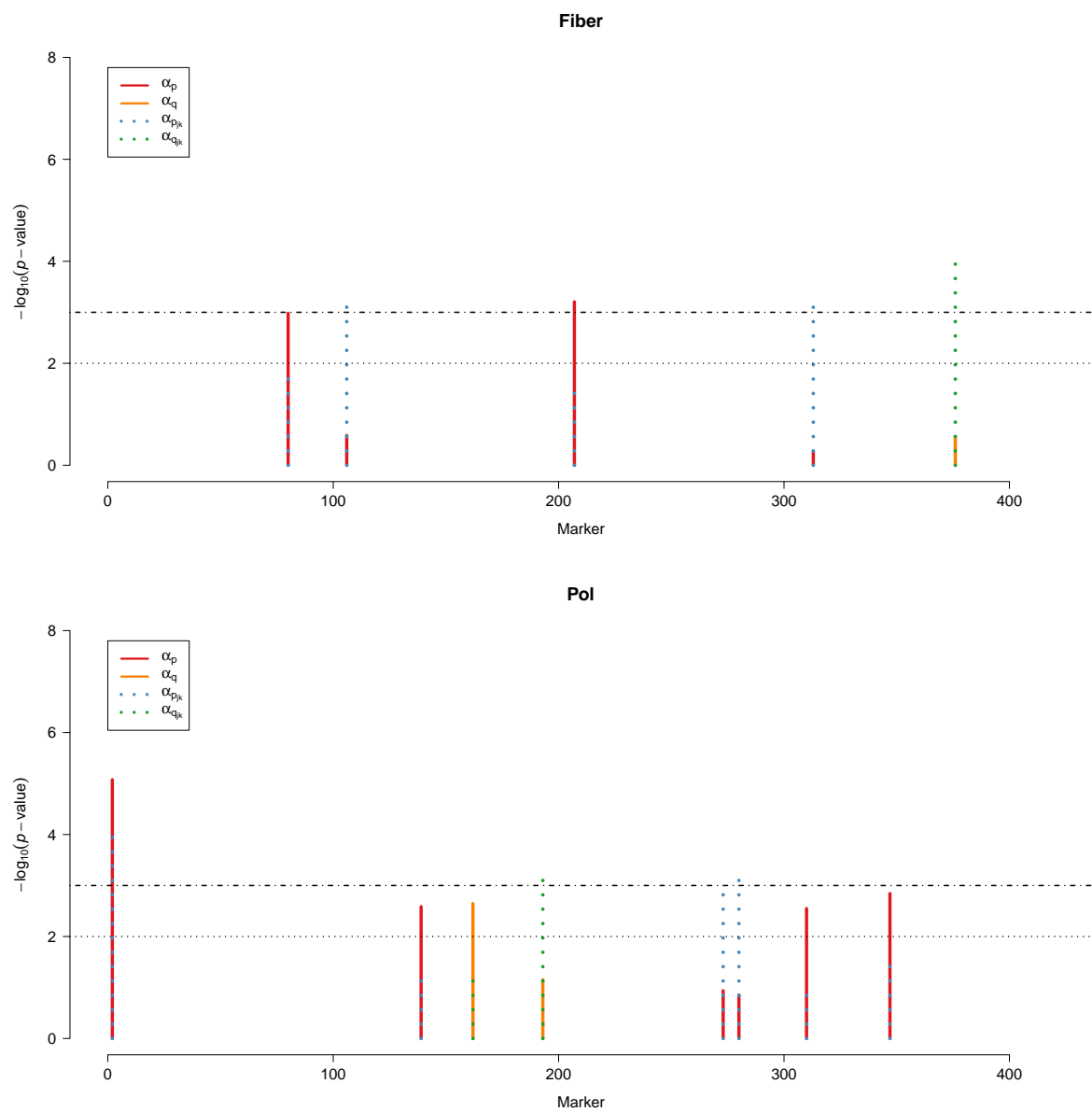

Fig. 4 (Contd.)

5

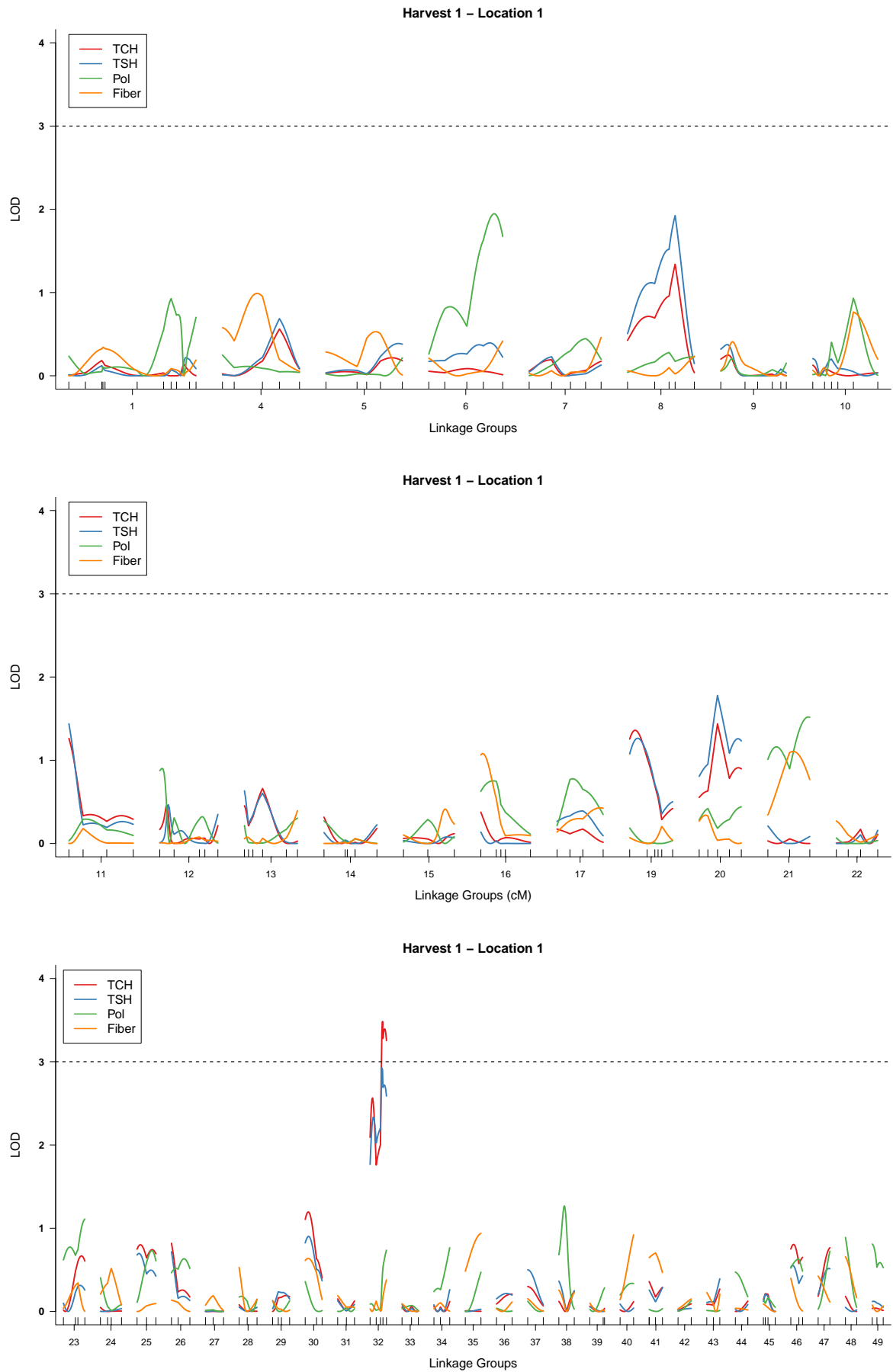

Fig. 5 Univariate QTL analysis of cane yield (tonnes of cane per hectare, TCH), sugar yield (tonnes of sugar per hectare, TSH), fiber content and sucrose content (Pol) carried out separately for each harvest-location combination.

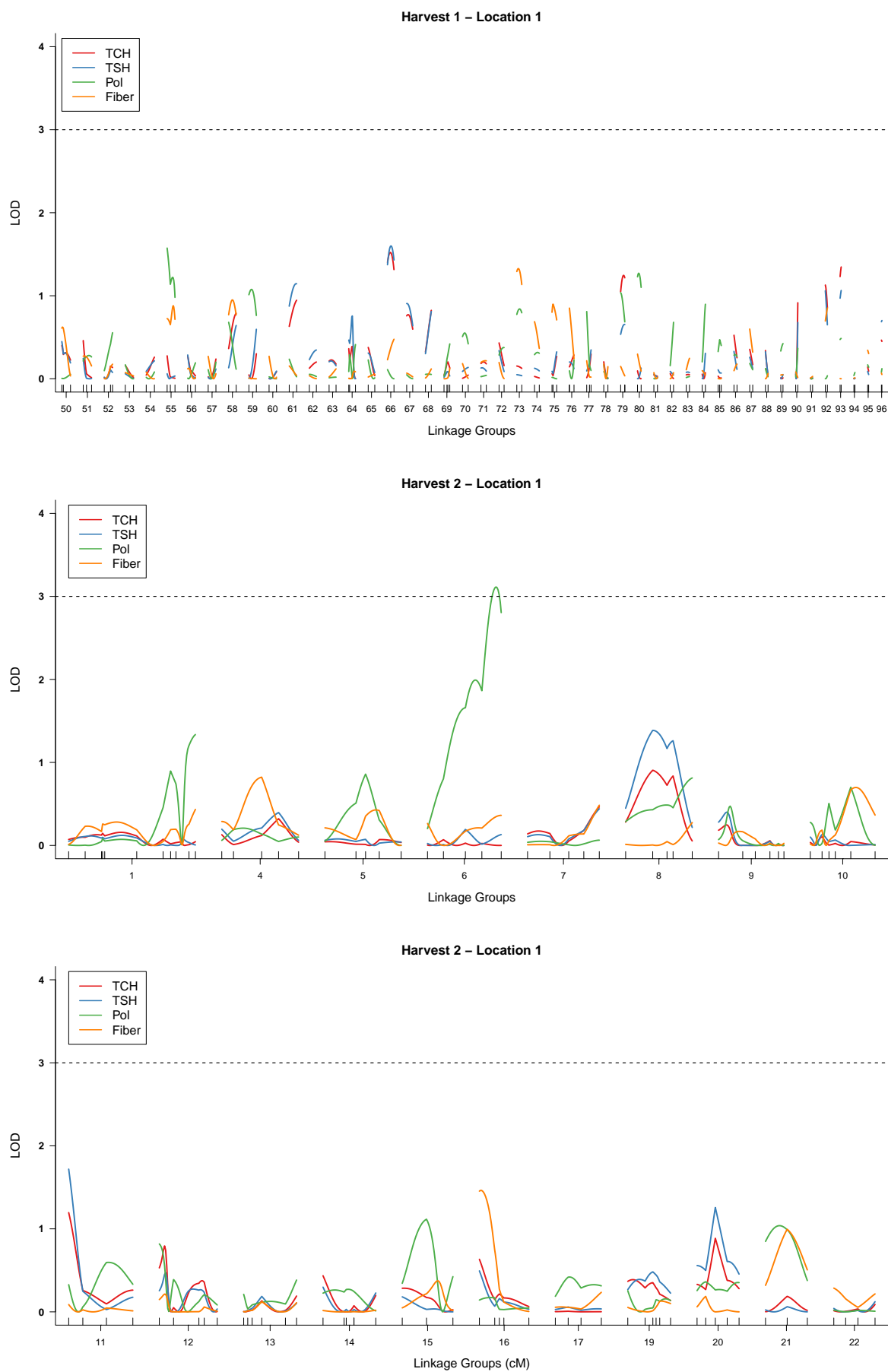

Fig. 5 (Contd.)

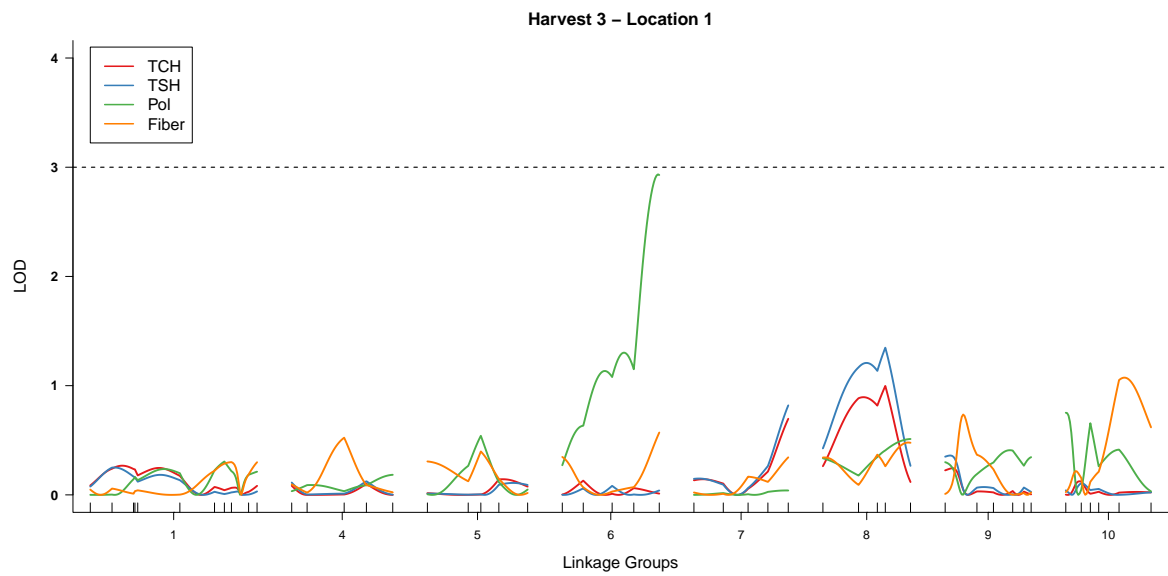
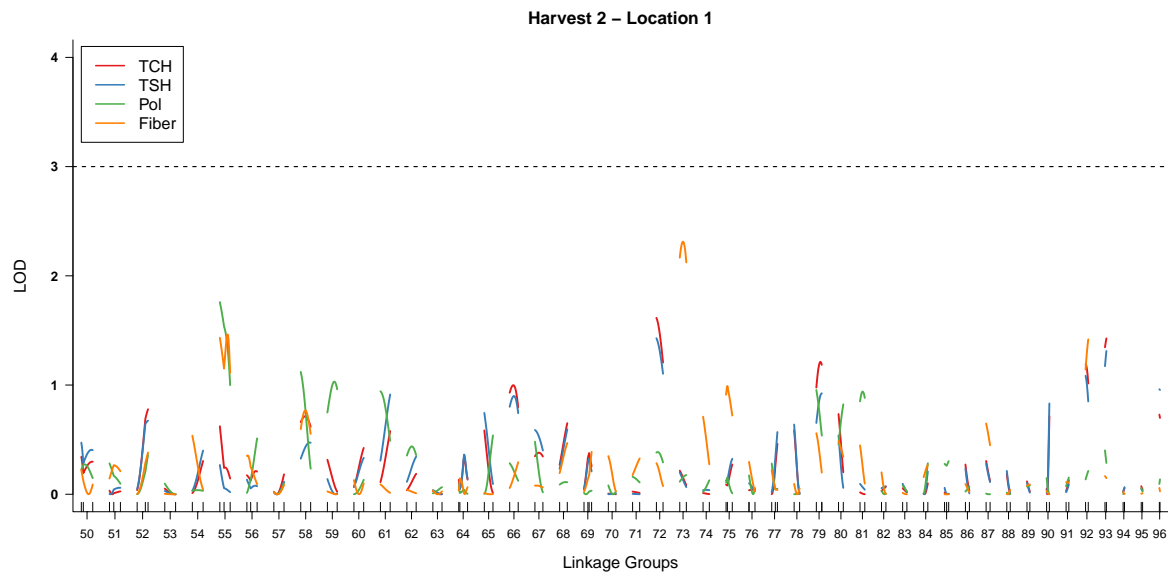
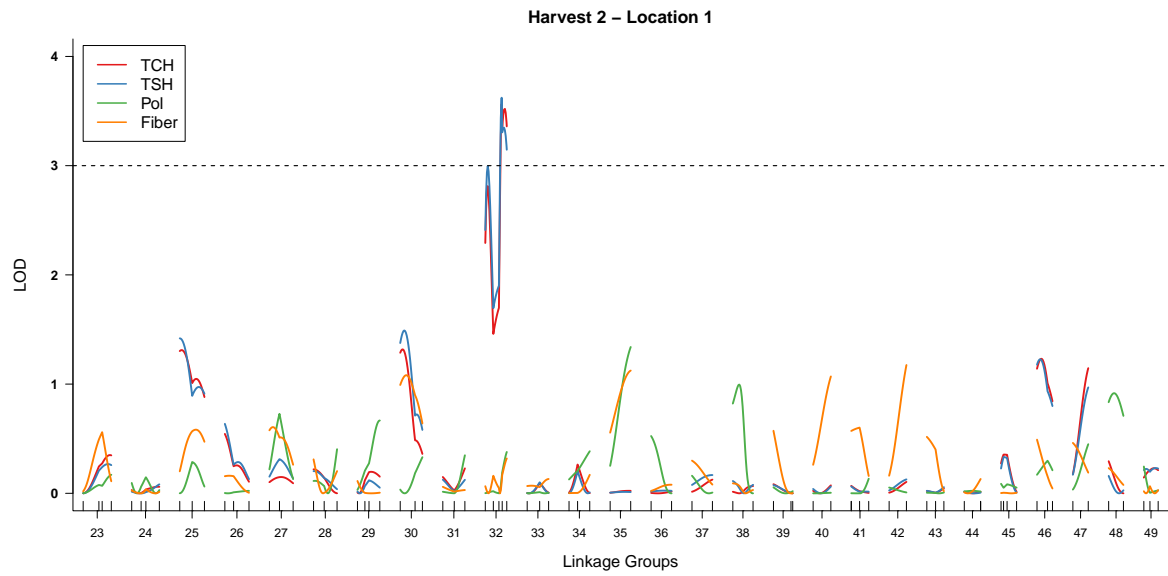

Fig. 5 (Contd.)

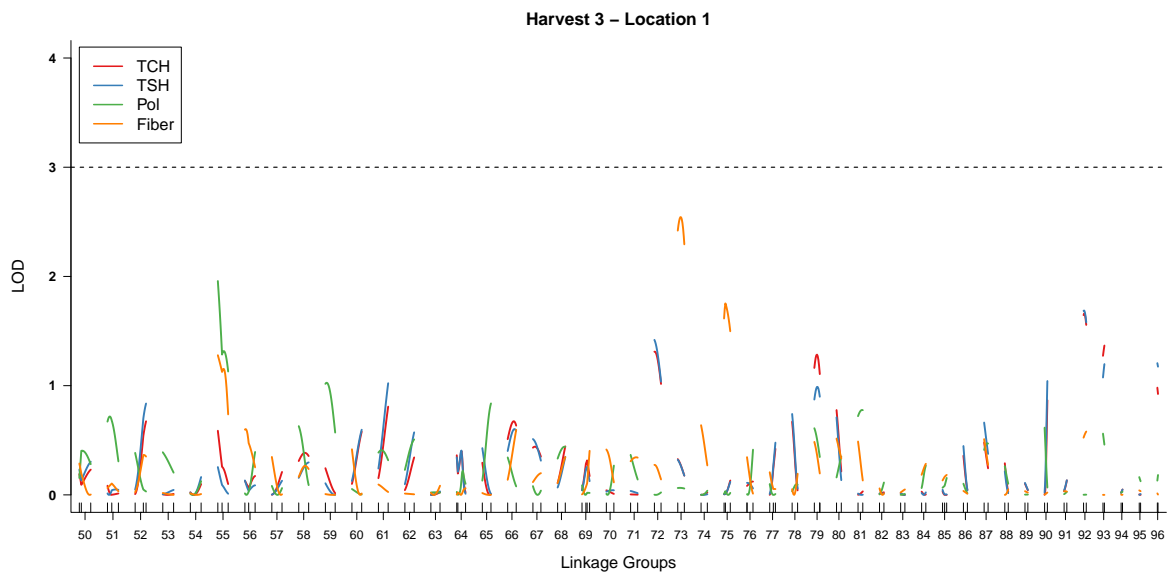
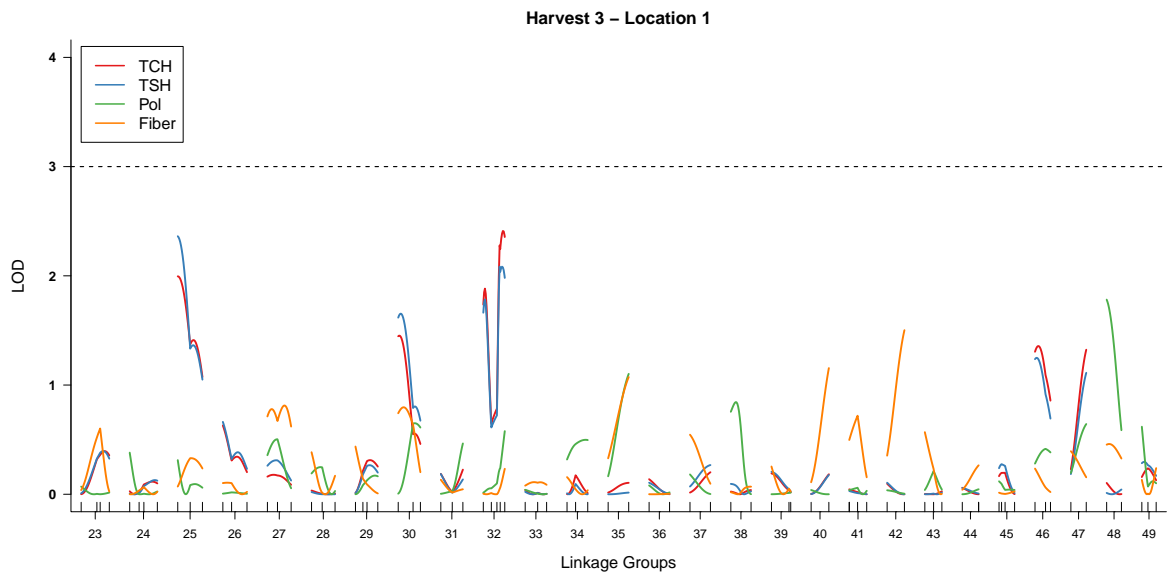
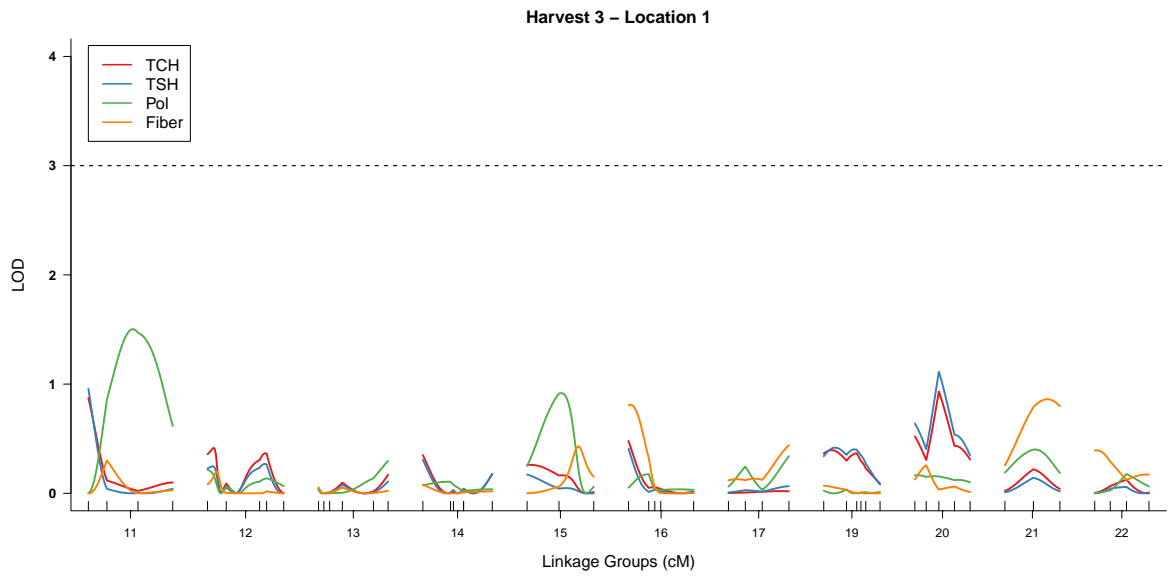

Fig. 5 (Contd.)

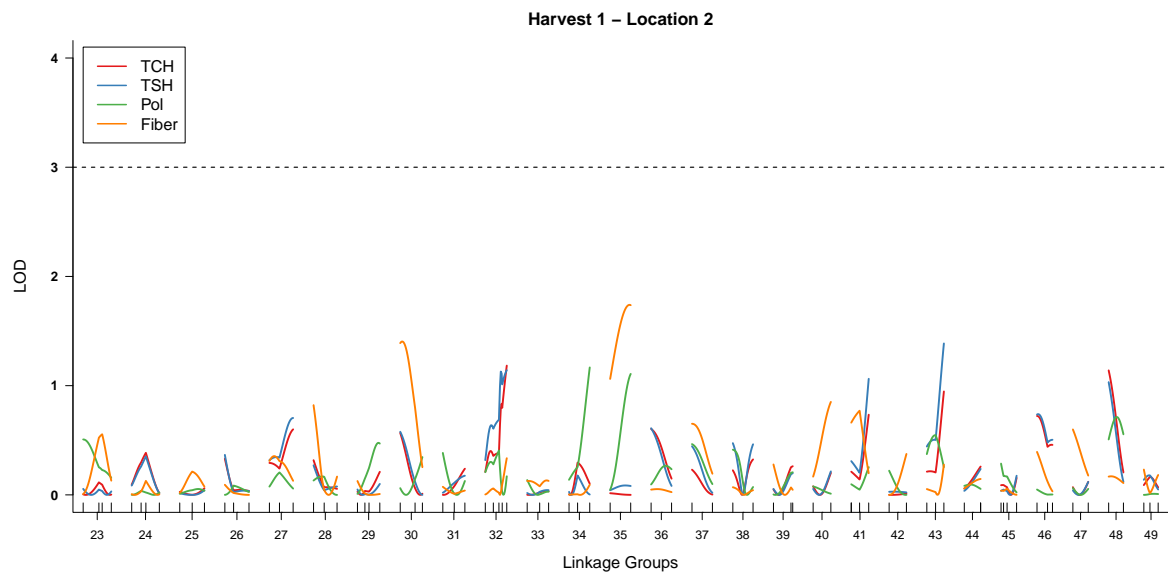
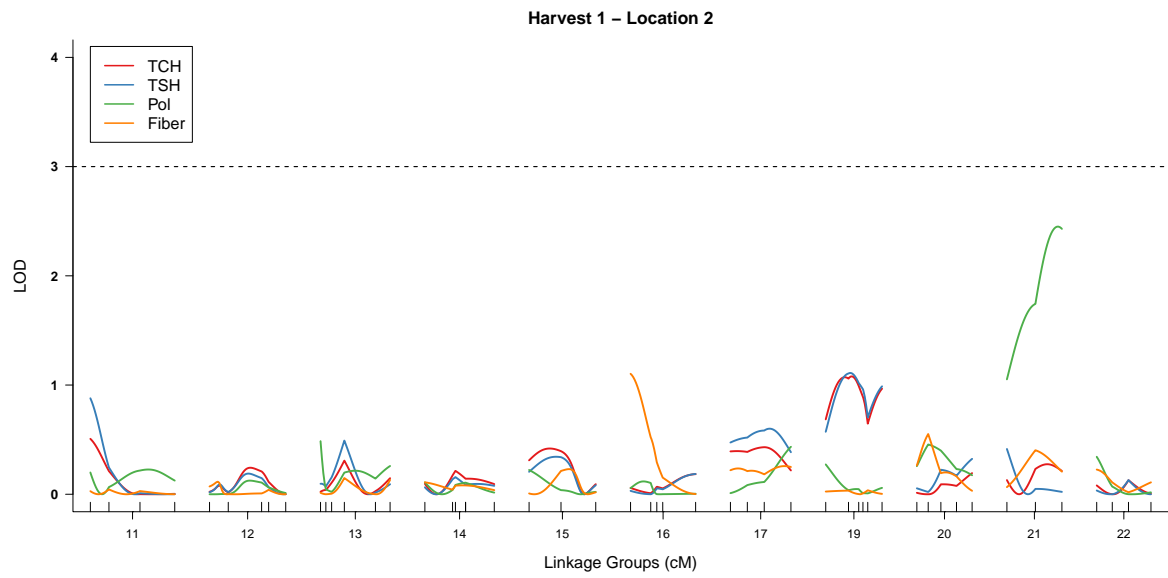
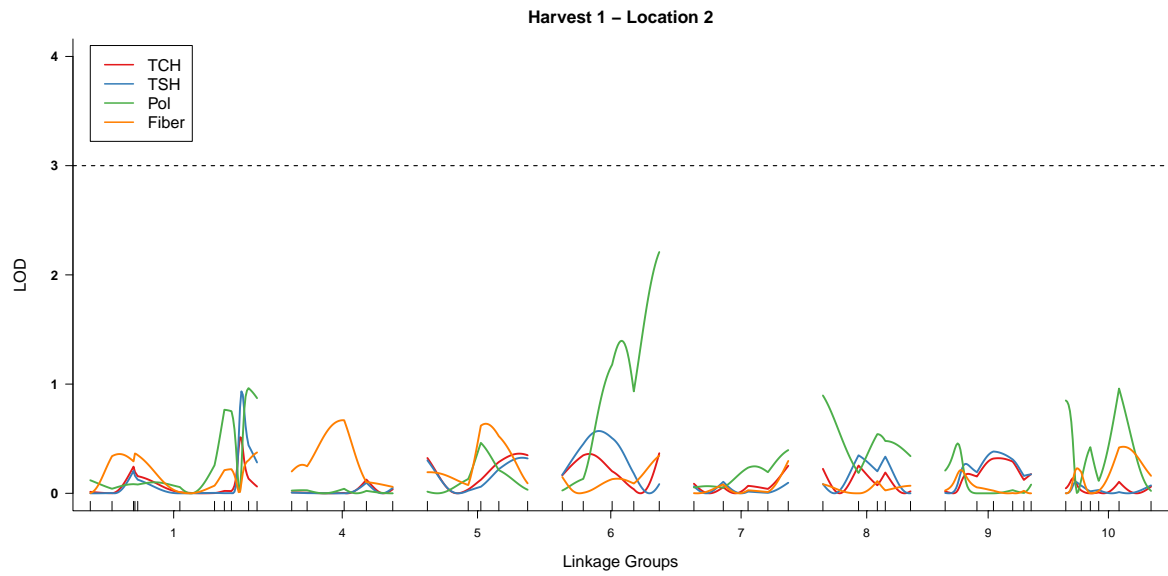

Fig. 5 (Contd.)

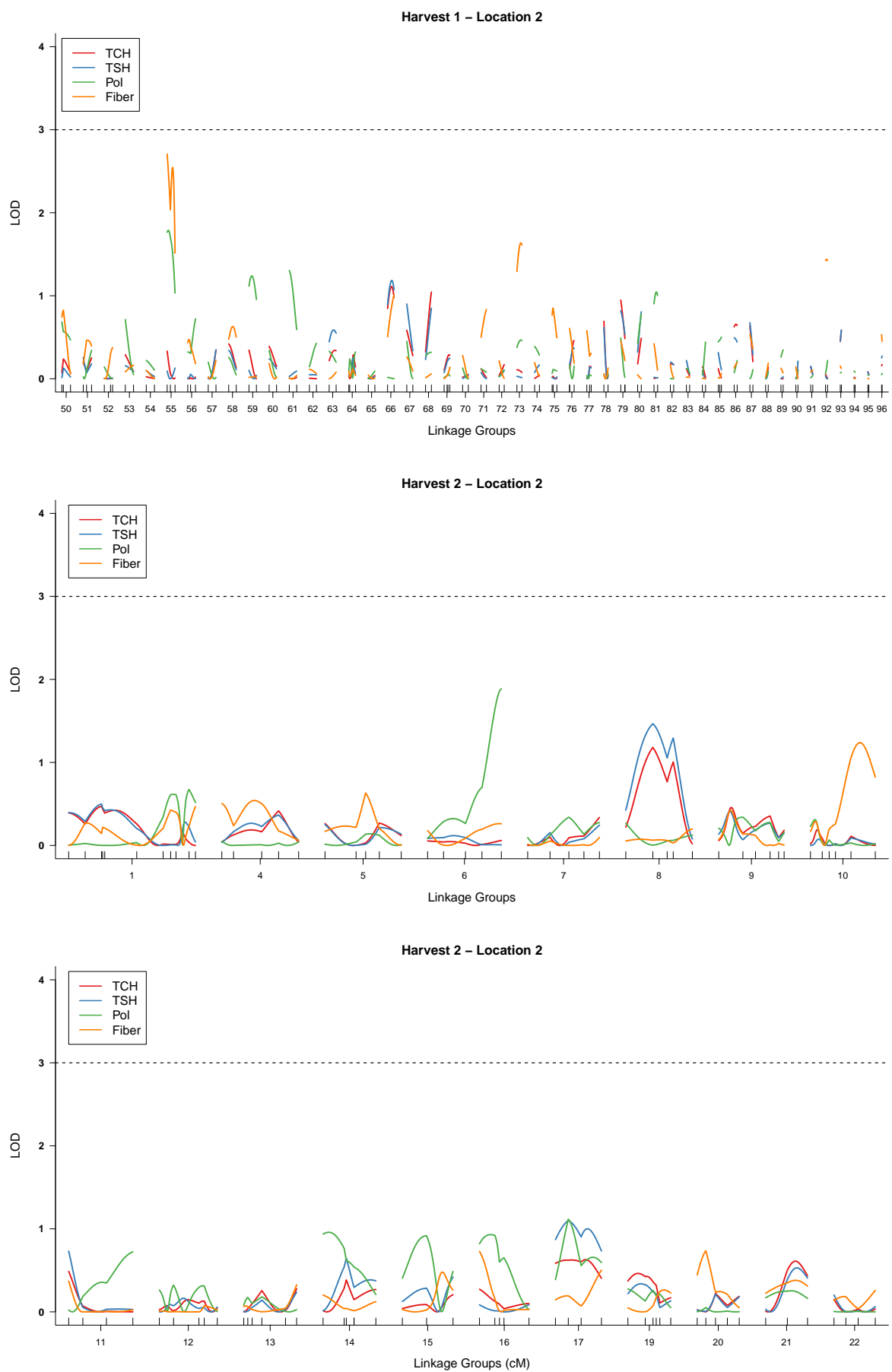

Fig. 5 (Contd.)

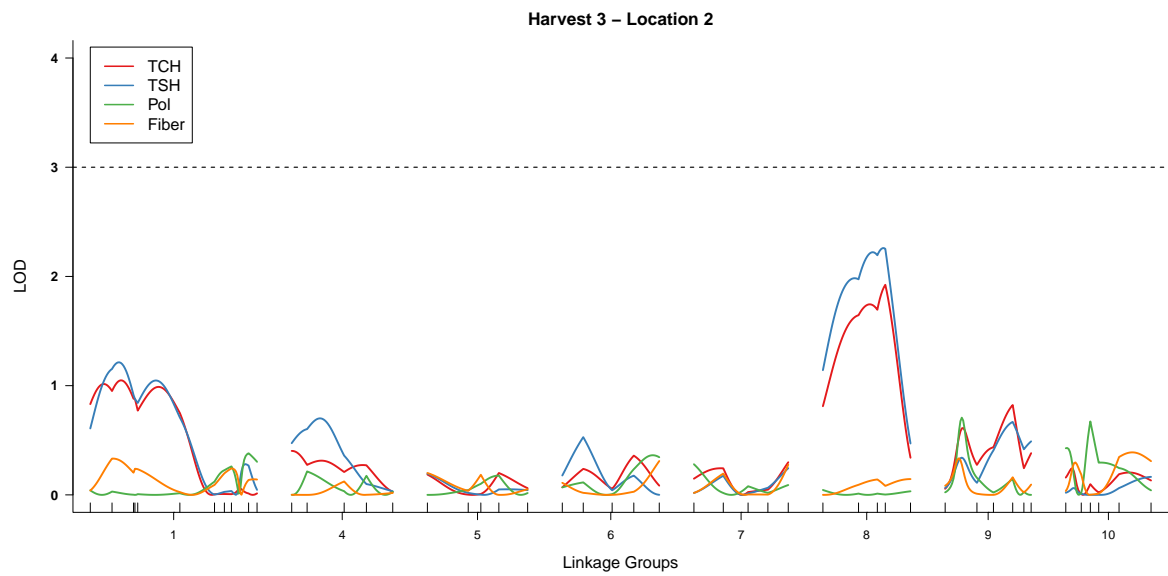
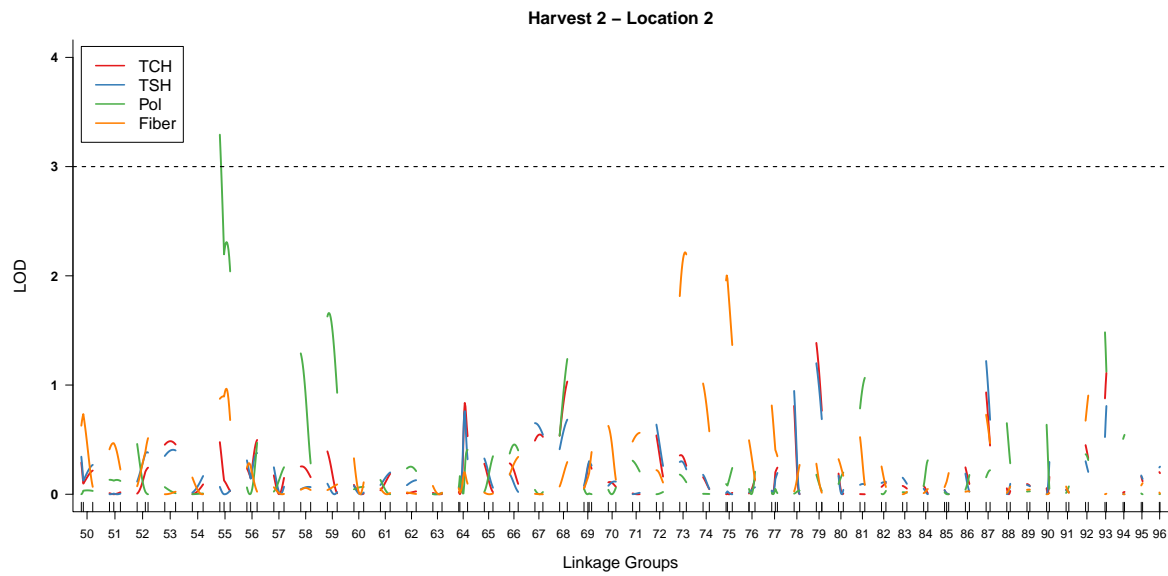
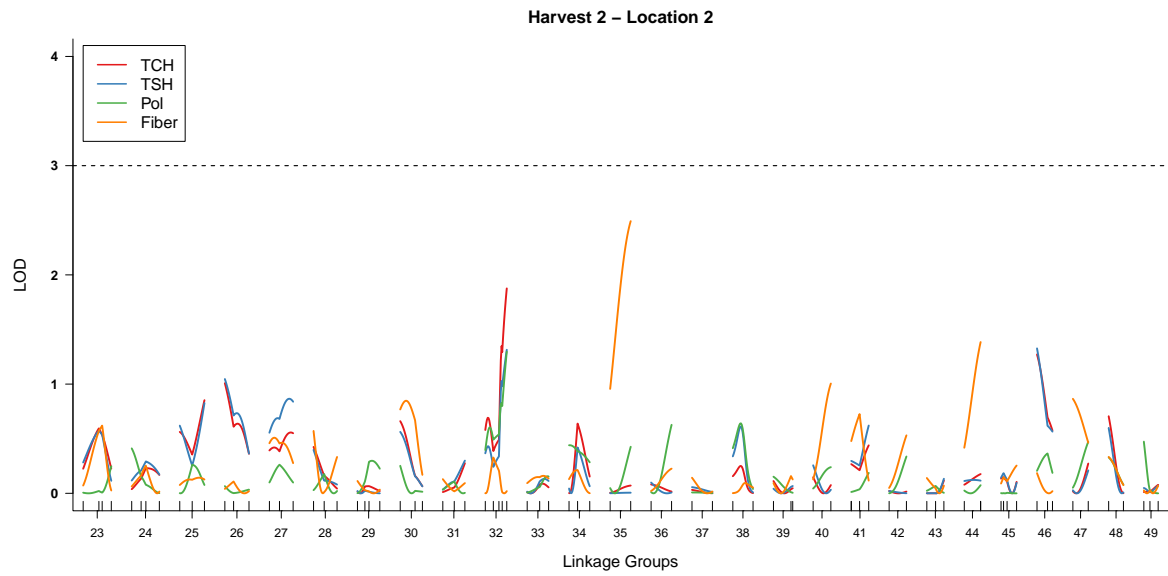

Fig. 5 (Contd.)

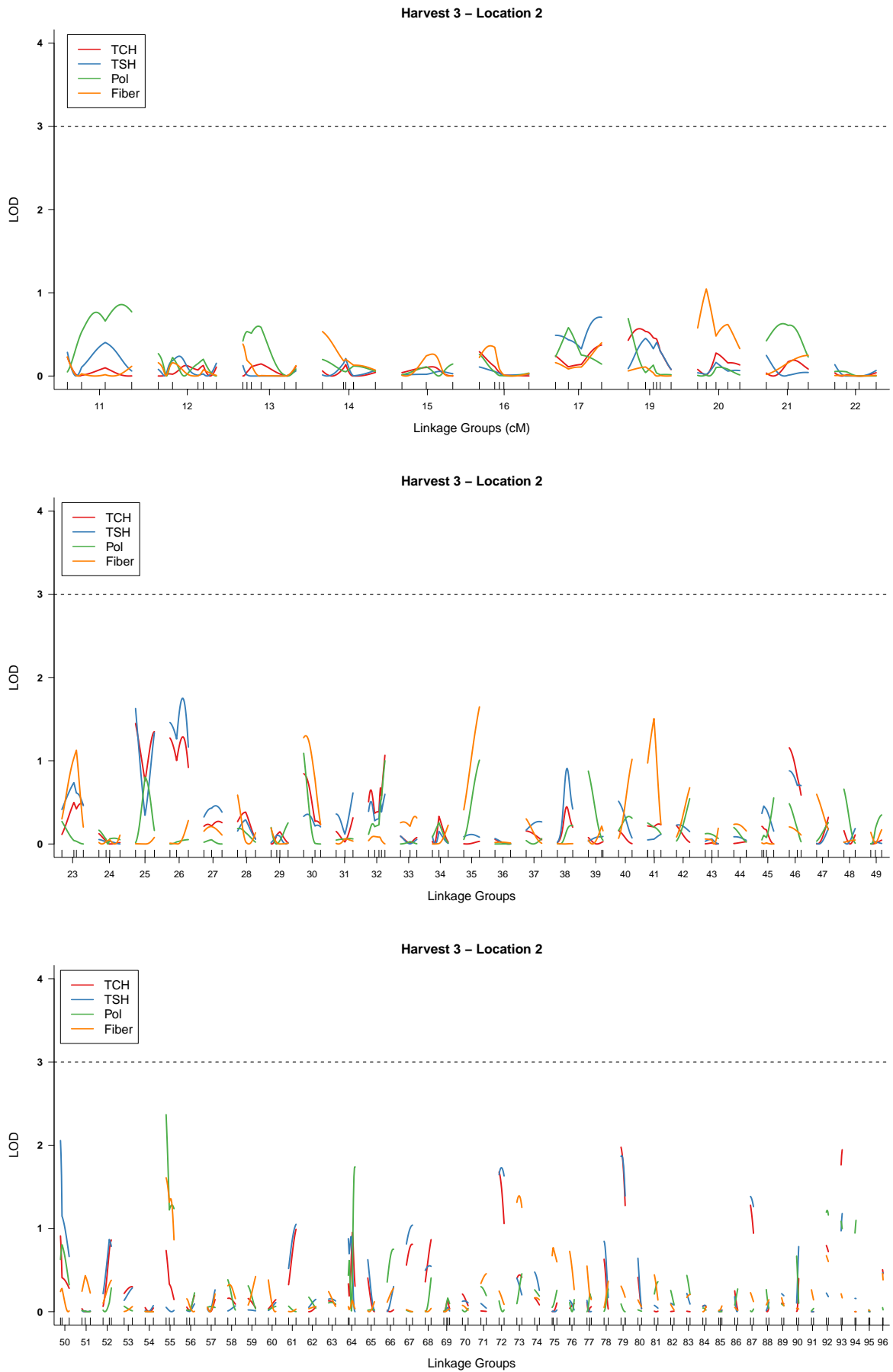

Fig. 5 (Contd.)