

Supplemental material

## **Genetic dissection of fruit quality traits in the octoploid cultivated strawberry highlights the role of homoeo-QTLs in their control**

E. Lerceteau-Köhler<sup>1,3</sup>, A. Moing<sup>2</sup>, G. Guérin<sup>2</sup>, C. Renaud<sup>2</sup>, C. Rothan<sup>2</sup>, B. Denoyes<sup>2\*</sup>

\* Corresponding author:

Béatrice Denoyes

INRA

UMR 1332 Biologie du Fruit et Pathologie

33883, Villenave d'Ornon Cedex

France

Tel: +33 5 57 12 24 60

Fax: +33 5 57 12 24 39

E-mail: denoyes@bordeaux.inra.fr

**Online Resource 3:** Locations of all the QTLs detected in this study for fruit traits (development (A), colour (B), texture (C), sugar related traits (D), acid related traits (E)) on linkage groups ranged by homoeologous groups. The linkage map is the consensus map obtained using JoinMap (Rousseau-Gueutin et al 2008). Linkage group names for the octoploid consist of the number of the HG to which they belong followed by a letter arbitrarily allocated (a, b, c or d). The first linkage group belongs to the diploid reference linkage map and allow to anchor common markers with and between *F. × ananassa* linkage groups. The position of the QTL on the consensus map is the one of the closest marker to the QTL on the parental maps.

Fruit traits are the following: Development: FD fruit diameter, FL fruit length, FD/FL ratio, DW dry weight, FW fruit weight, RD ripening date of the fruit. Texture: FIRM fruit firmness. Colour: skin colour parameters L, a and b, ANTH total anthocyanin. Sugar related traits: SSC soluble-solids content, FRU fructose, GLU glucose, SUCR sucrose. Acid related traits : pH, TA titratable acidity, CIT citrate, MAL malate.

**A**

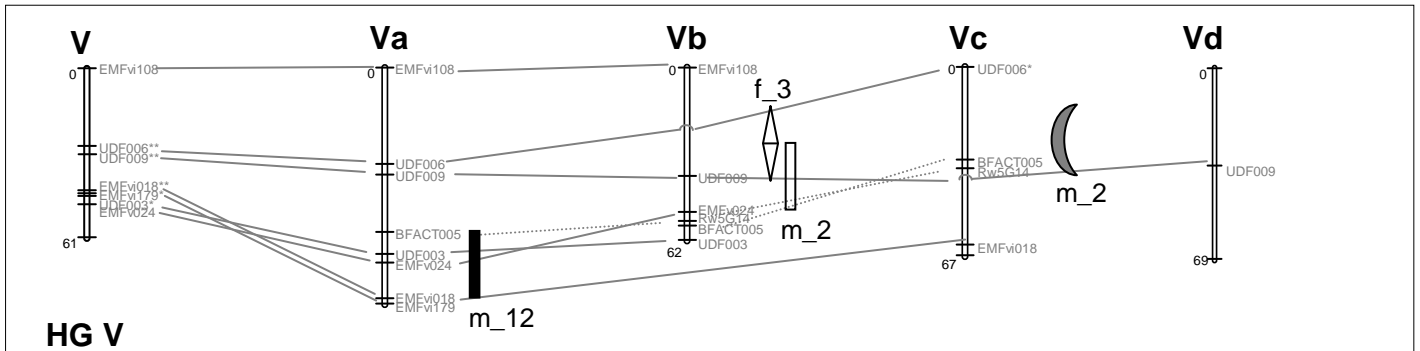
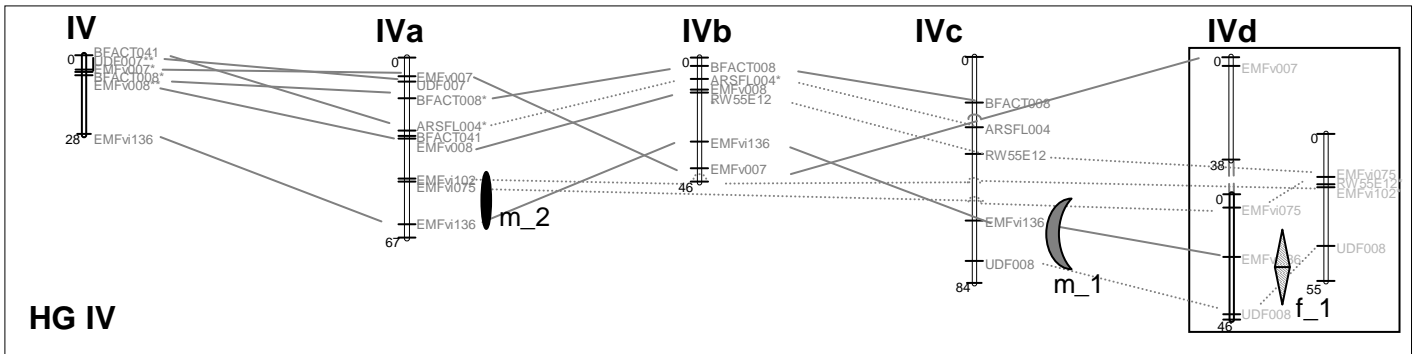
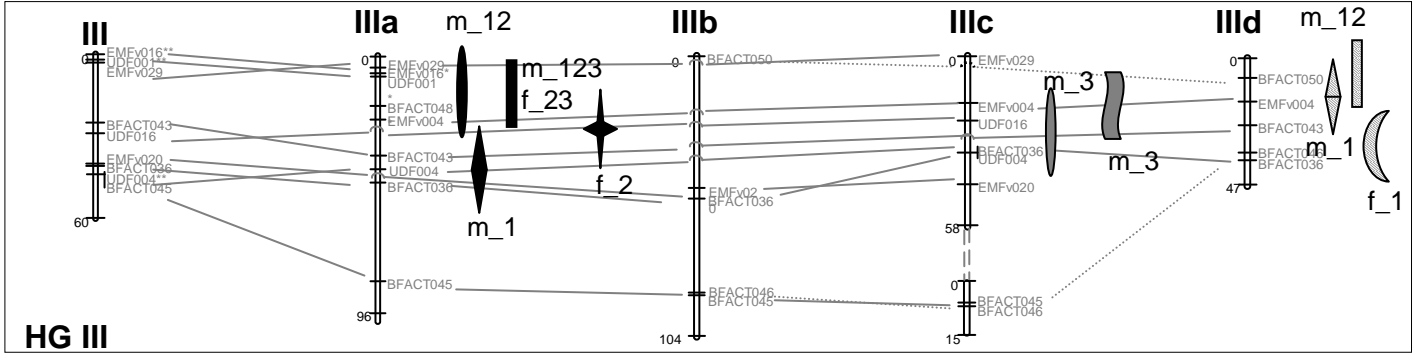
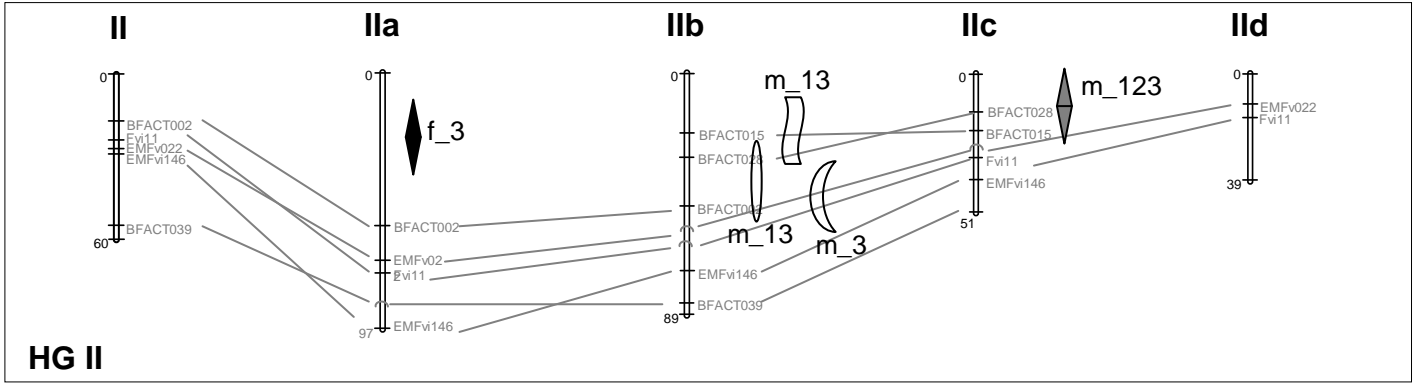
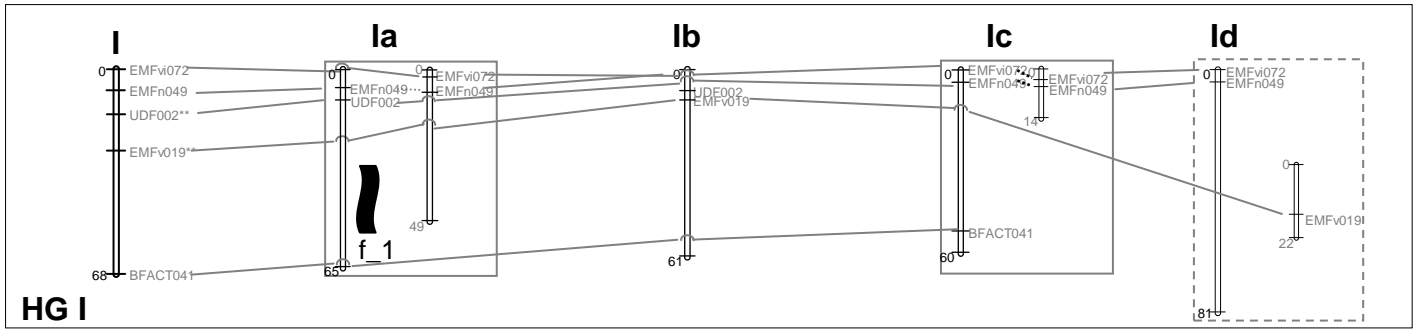

**A-continued**

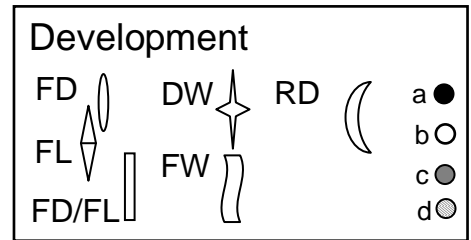
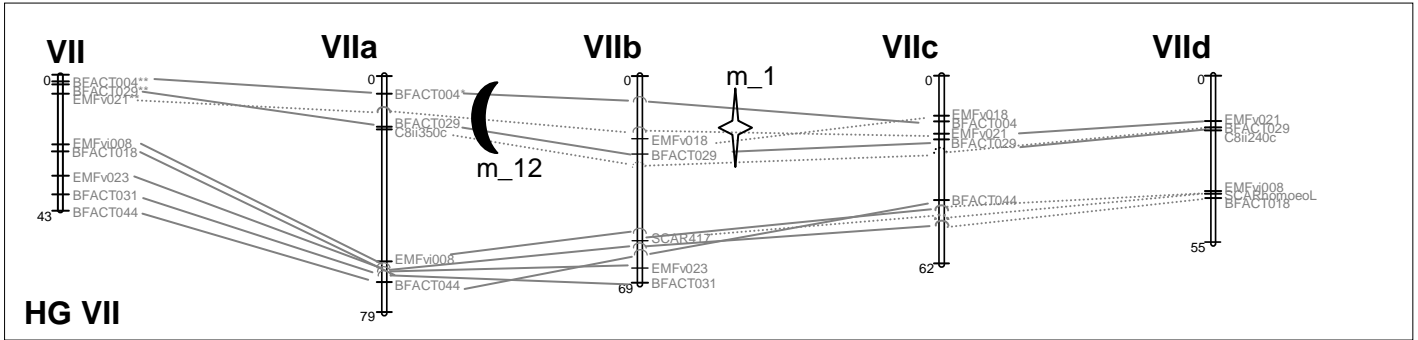
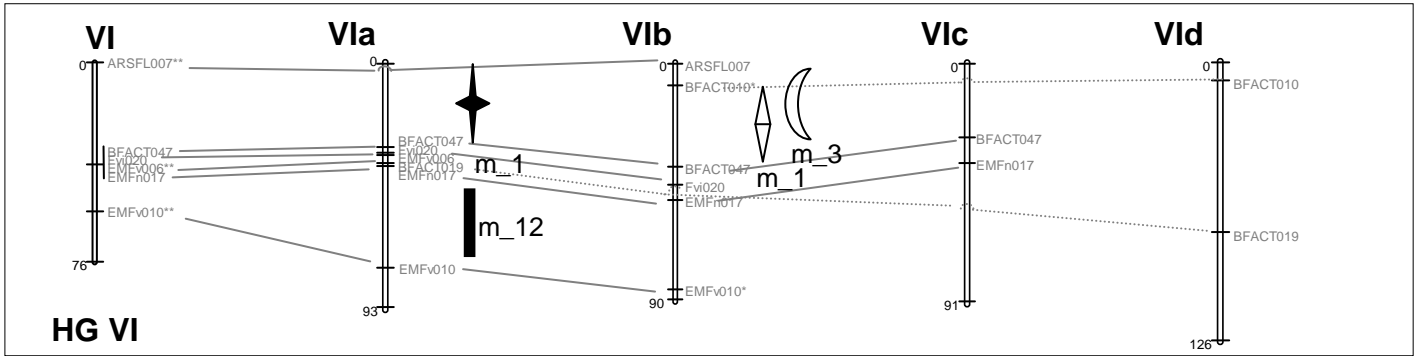

**B**

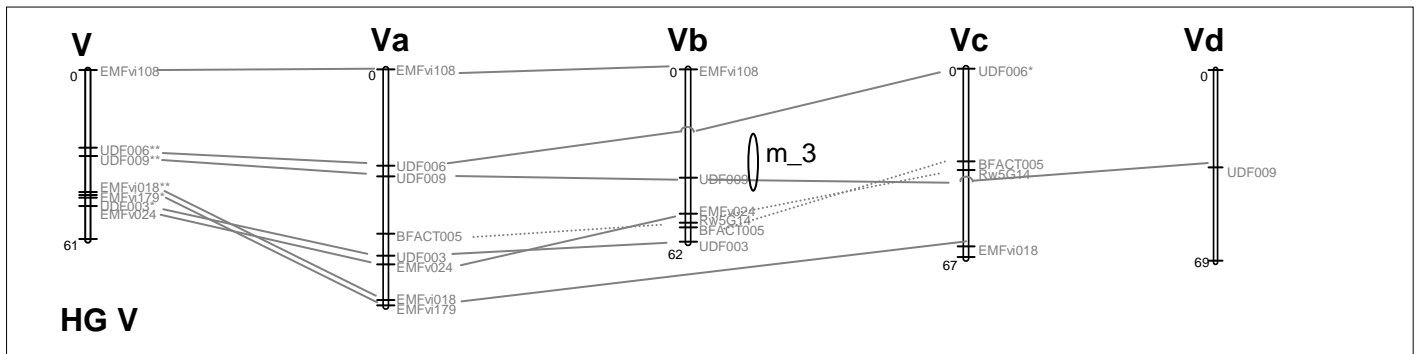
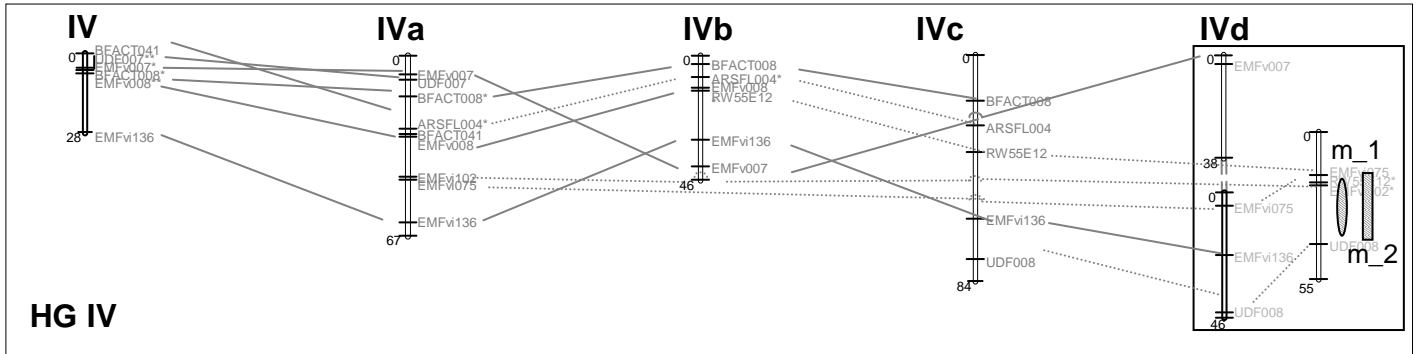
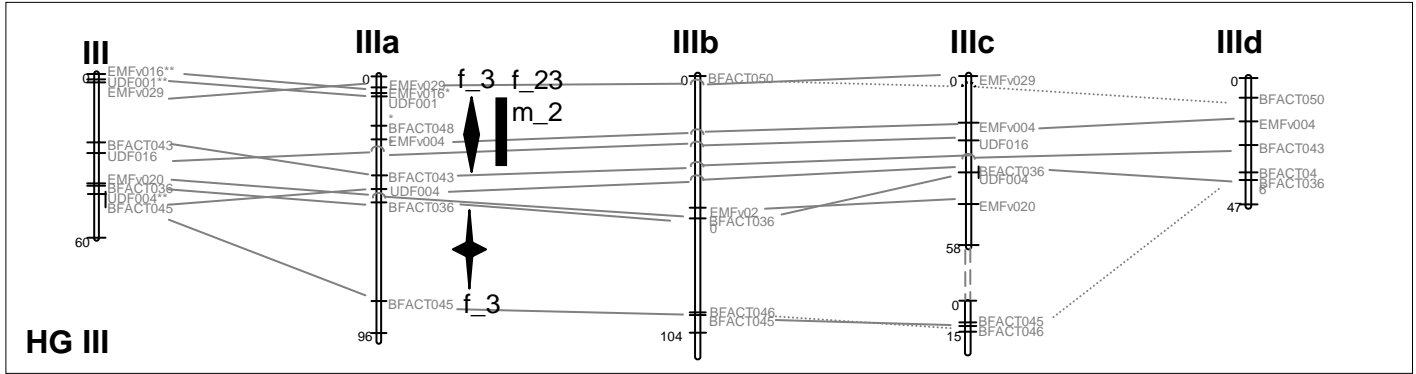
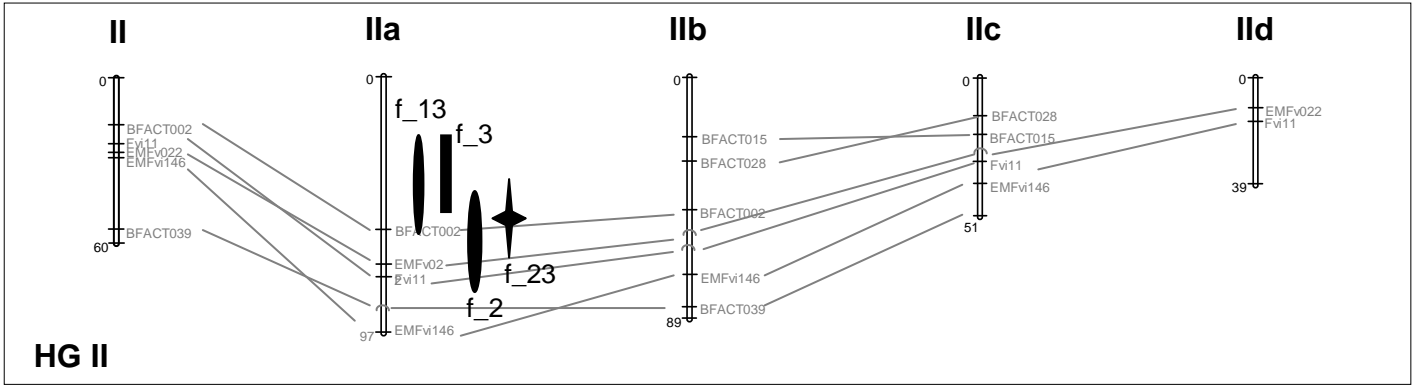
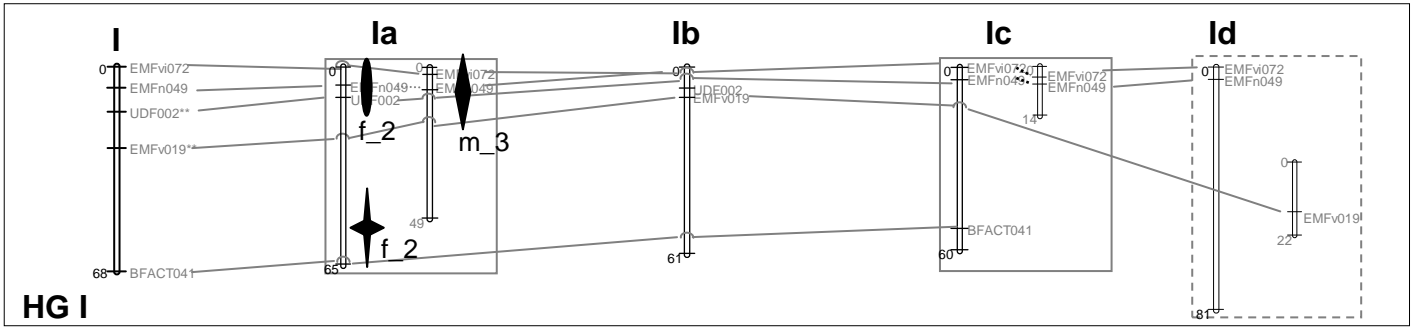

**B**-continued

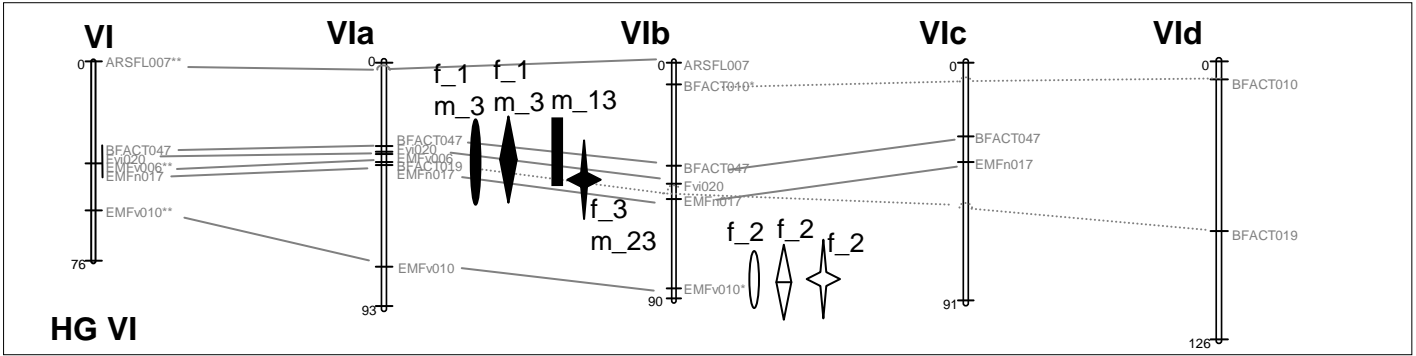

**HG VI**

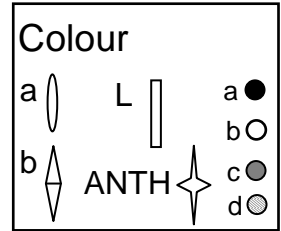

**C**

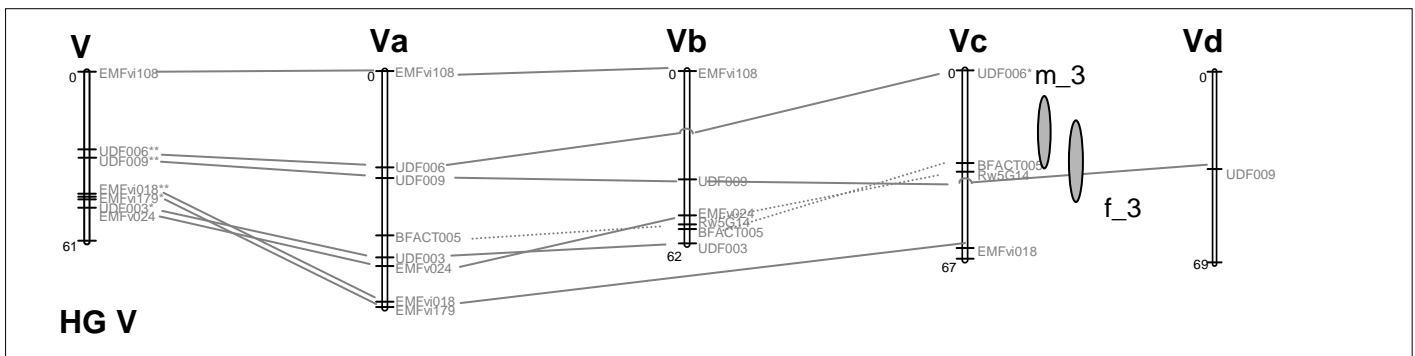
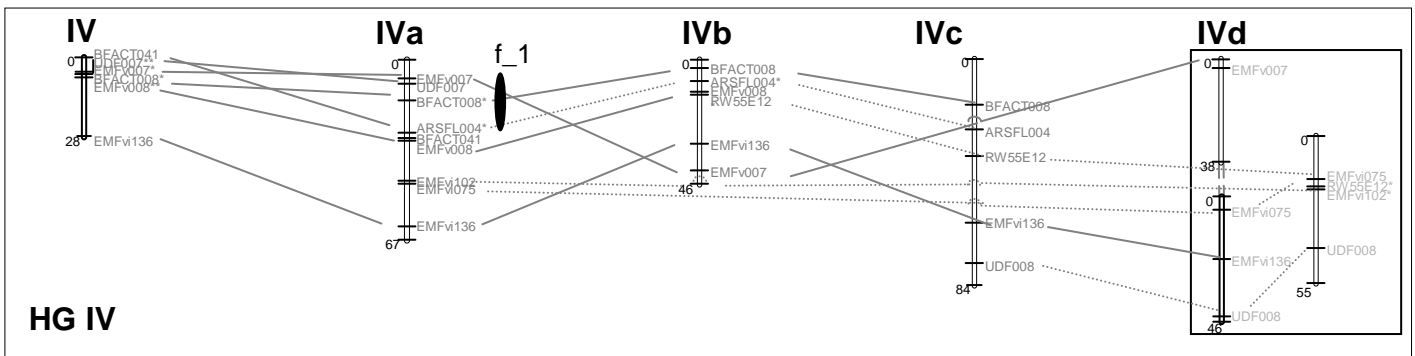
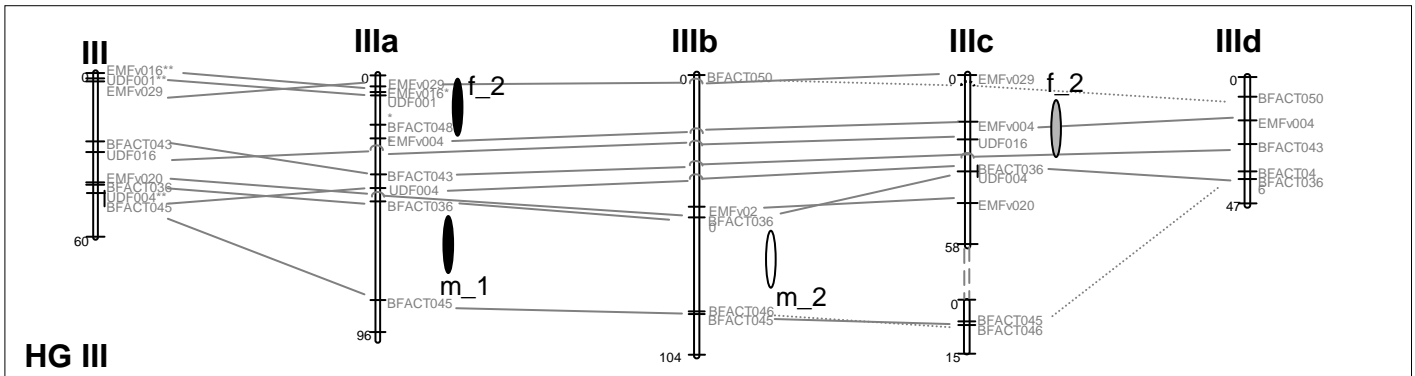
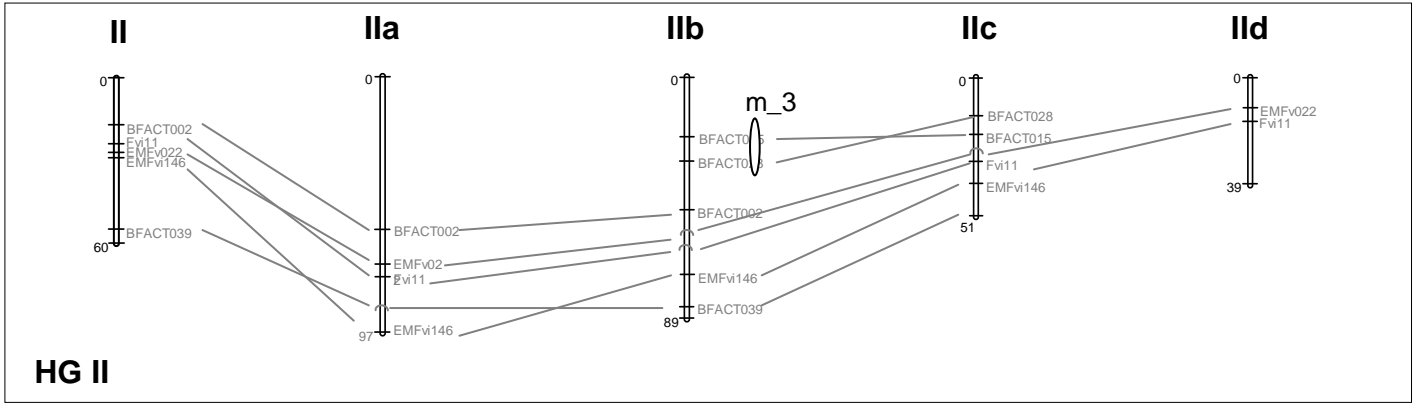

**Texture**

**FIRM**

- a ●
- b ○
- c ●
- d ○

**D**

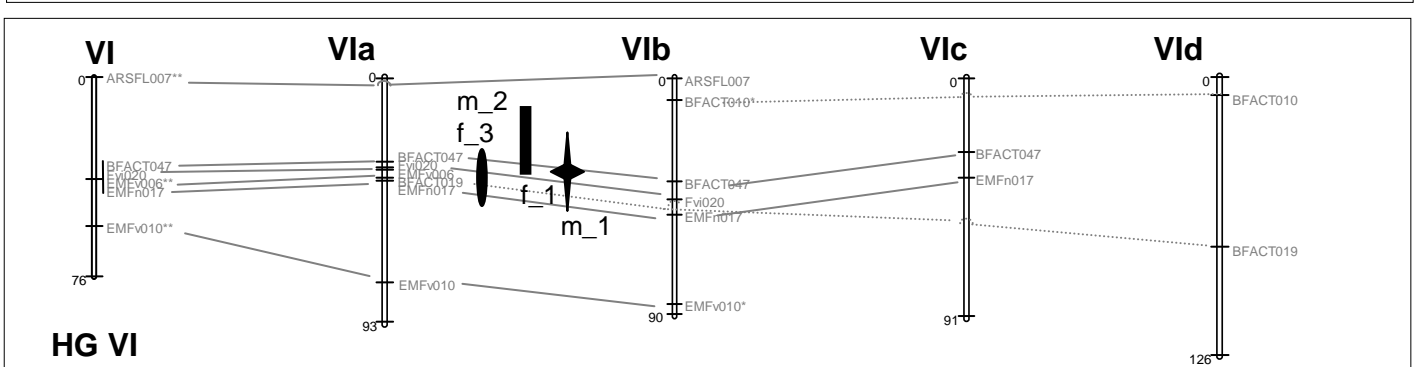
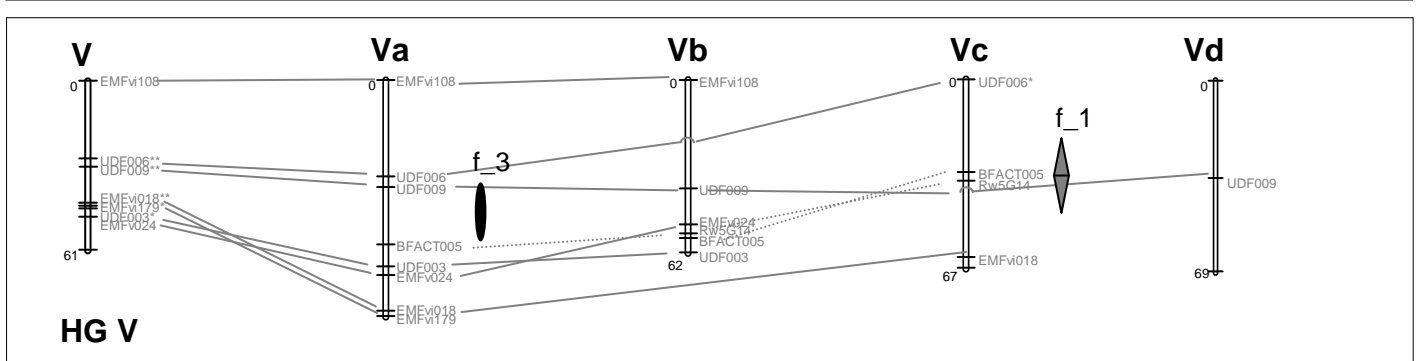
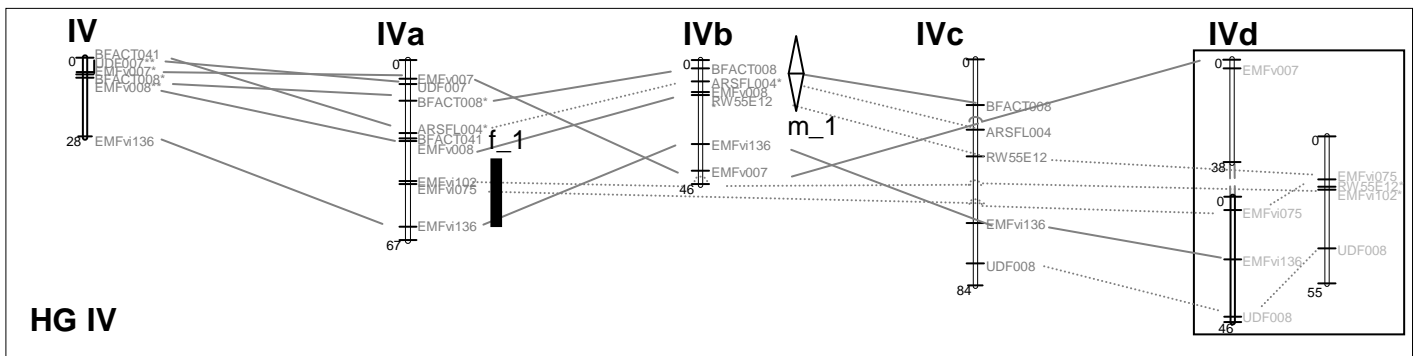
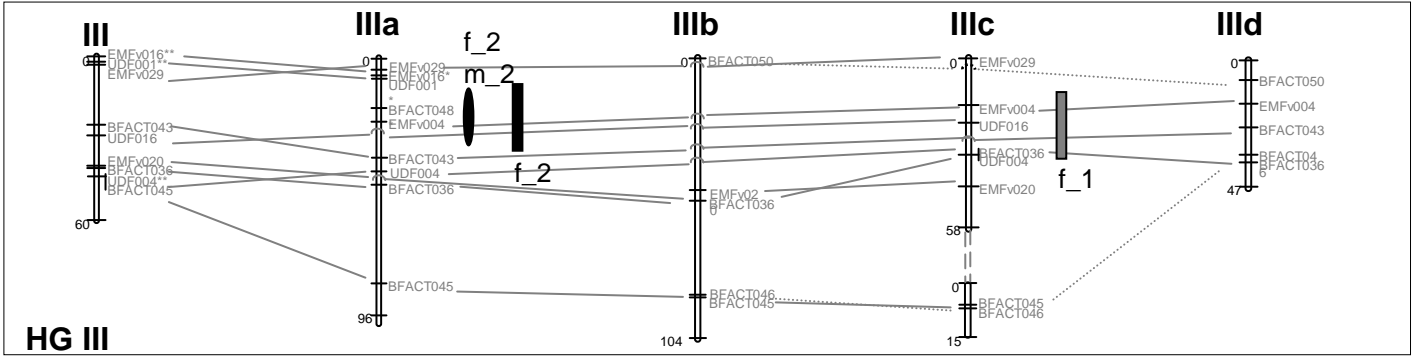
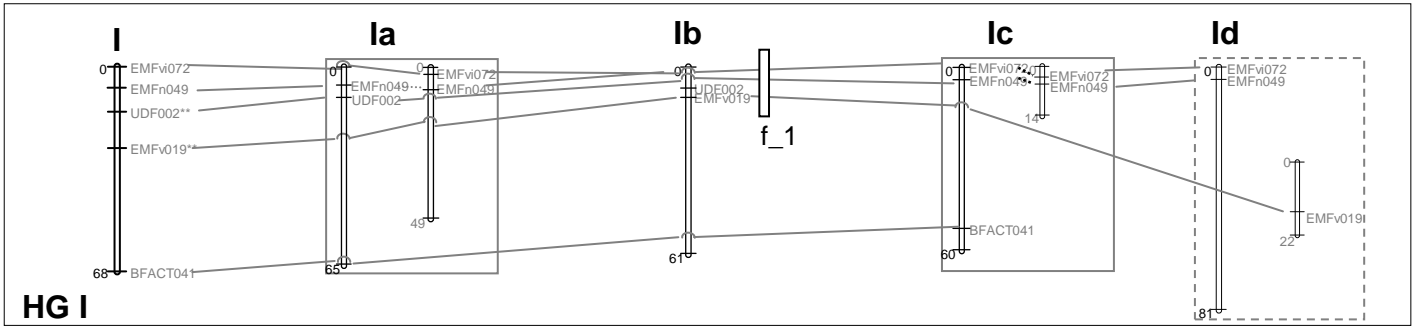

**D**-continued

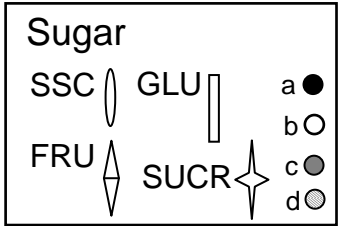
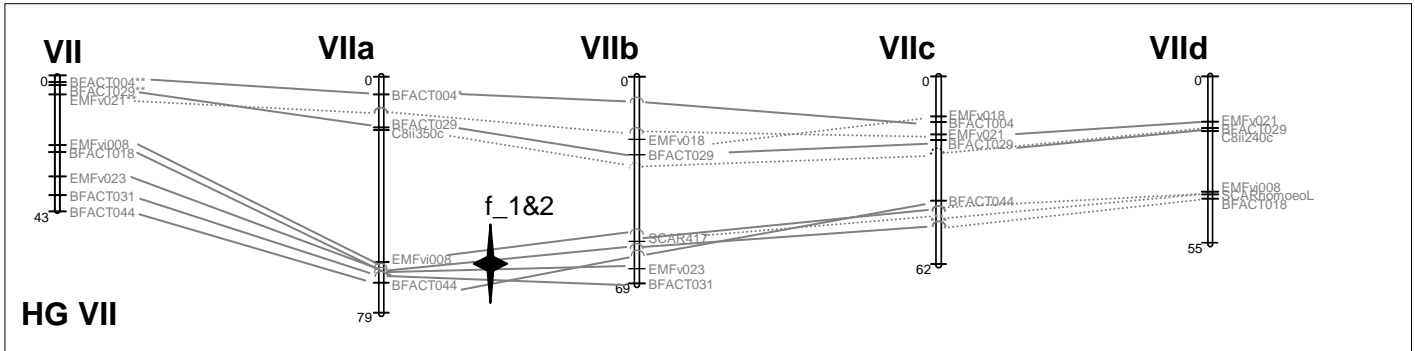



**E**

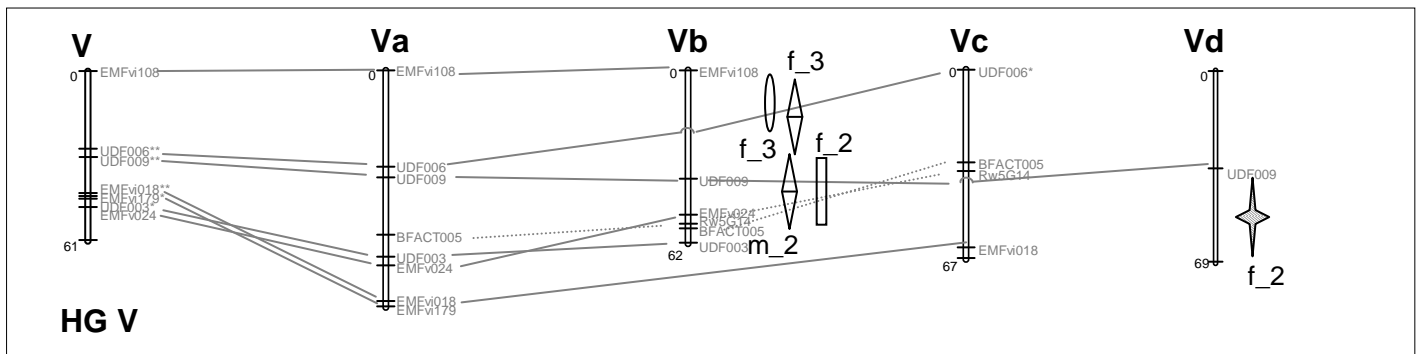
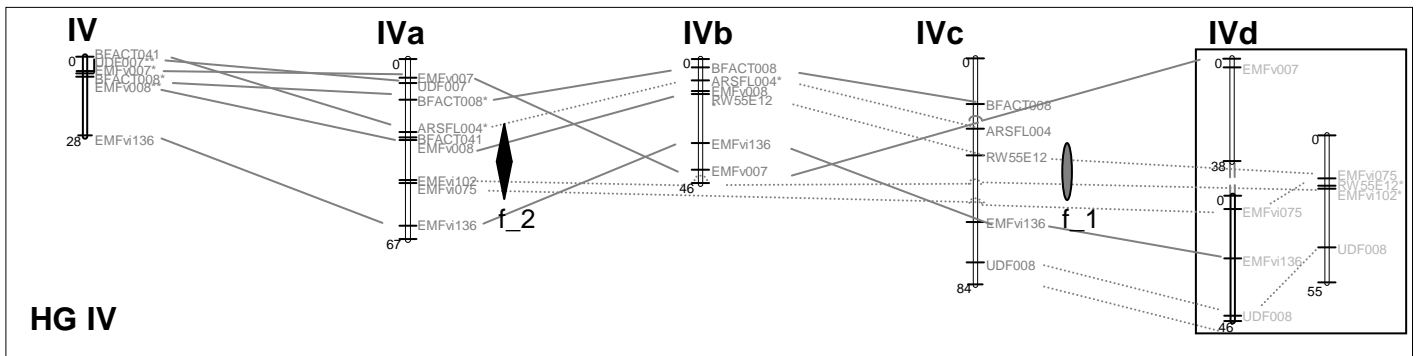
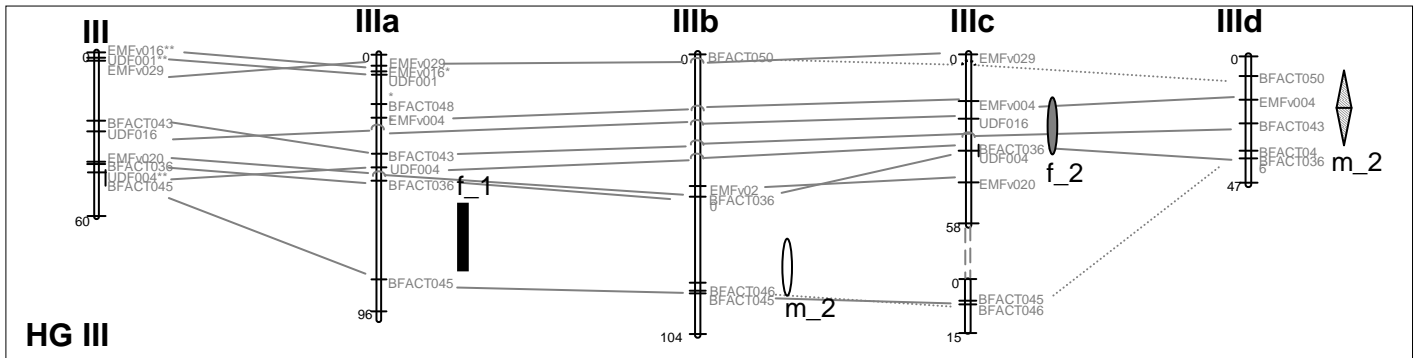
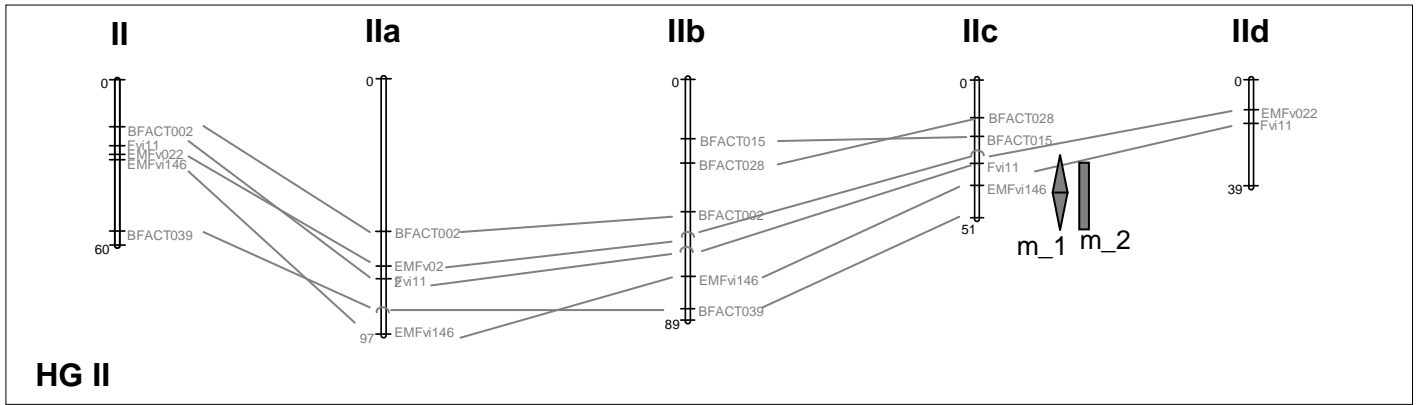
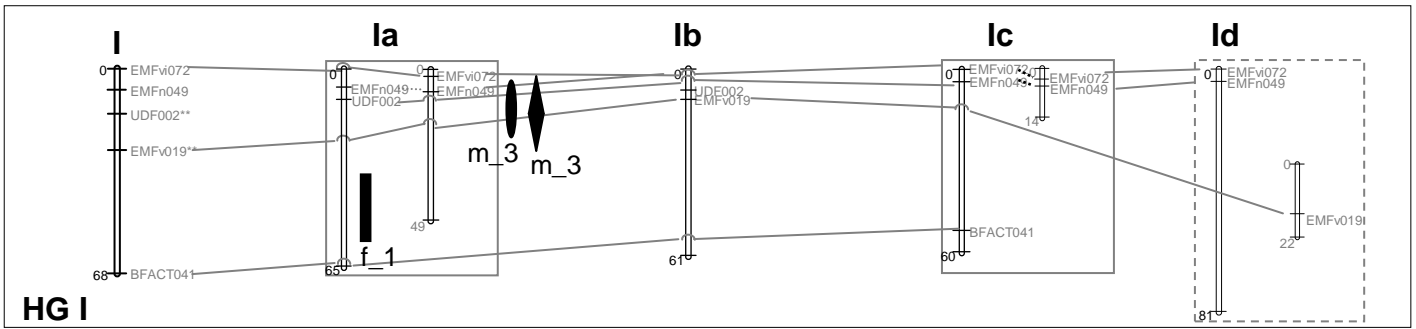

**E**-continued

