

Figure S1. Description of Class A1 (A2) events. In Fig. S1-S40, we show the mechanisms needed to explain the classes of conversions/crossovers shown in Tables S1 and S2. Each sectored colony is shown as a pair of line segments of various colors: green (heterozygous SNPs), red (SNPs homozygous for W303a SNPs), and black (SNPs homozygous for YJM789 SNPs); segments are not drawn to scale. DNA molecules are drawn as double-stranded structures with red lines representing W303a sequences and black lines representing YJM789 sequences. Dotted lines indicate repair-associated DNA synthesis. Heteroduplexes are enclosed in blue boxes. Prior to mismatch repair, heteroduplexes have red and blue strands. After repair, both strands have the same color. Chromatids are numbered 1 to 4, and blue arrows show chromosome segregation. In Class A events, there is a single 3:1 or 1:3 conversion tract unassociated with a crossover. Such events can be explained as a consequence of the repair of a single DSB in G2 by the SDSA pathway.

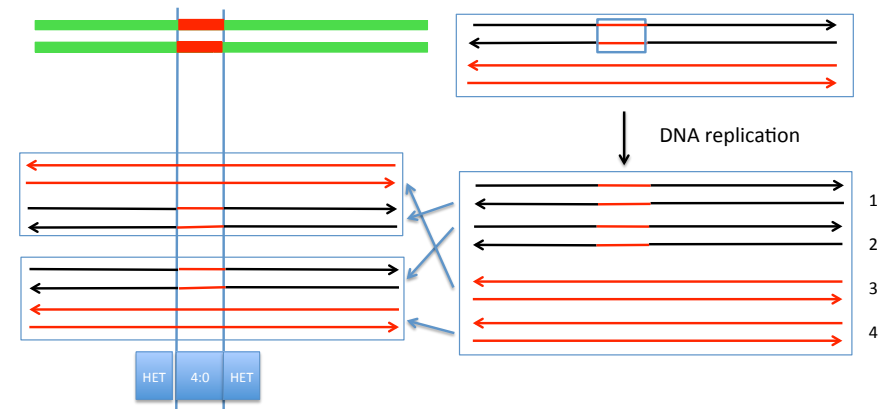
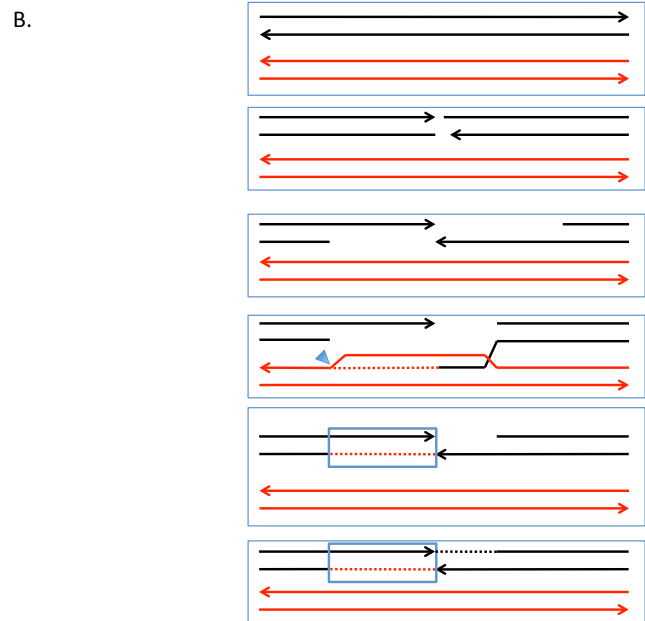
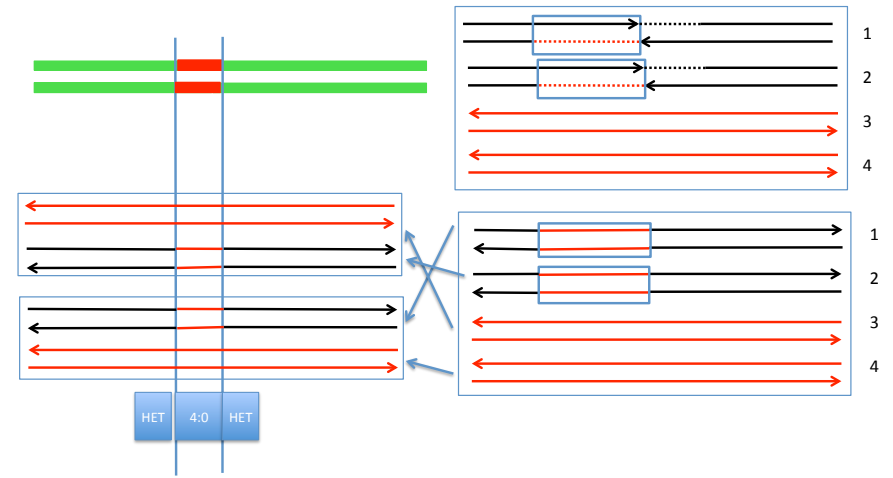
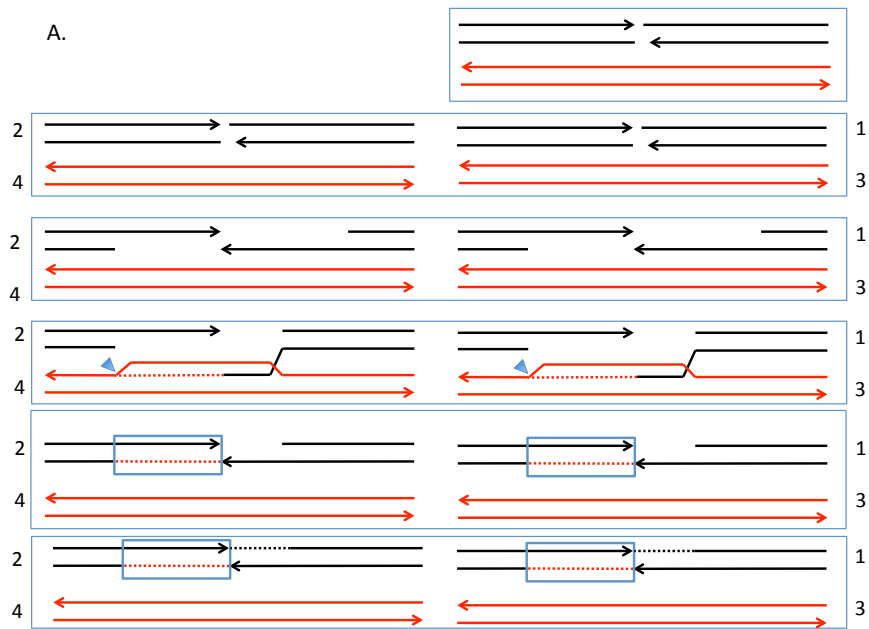

Figure S2. Generation of Class B1 (B2) by two different mechanisms. Class B events have a single 4:0 or 0:4 conversion tract unassociated with a crossover.
 A. Generation of Class B events by repair of two DSBs in G2 resulting from a single G1 DSB. Each DSB is repaired by an SDSA event in which the conversion tracts are of equal length.
 B. Generation of Class B events by repair of a G1 DSB in G1. Repair occurs by SDSA, followed by mismatch repair in G1. The resulting molecule is replicated to give two black chromatids with identical conversion tracts.

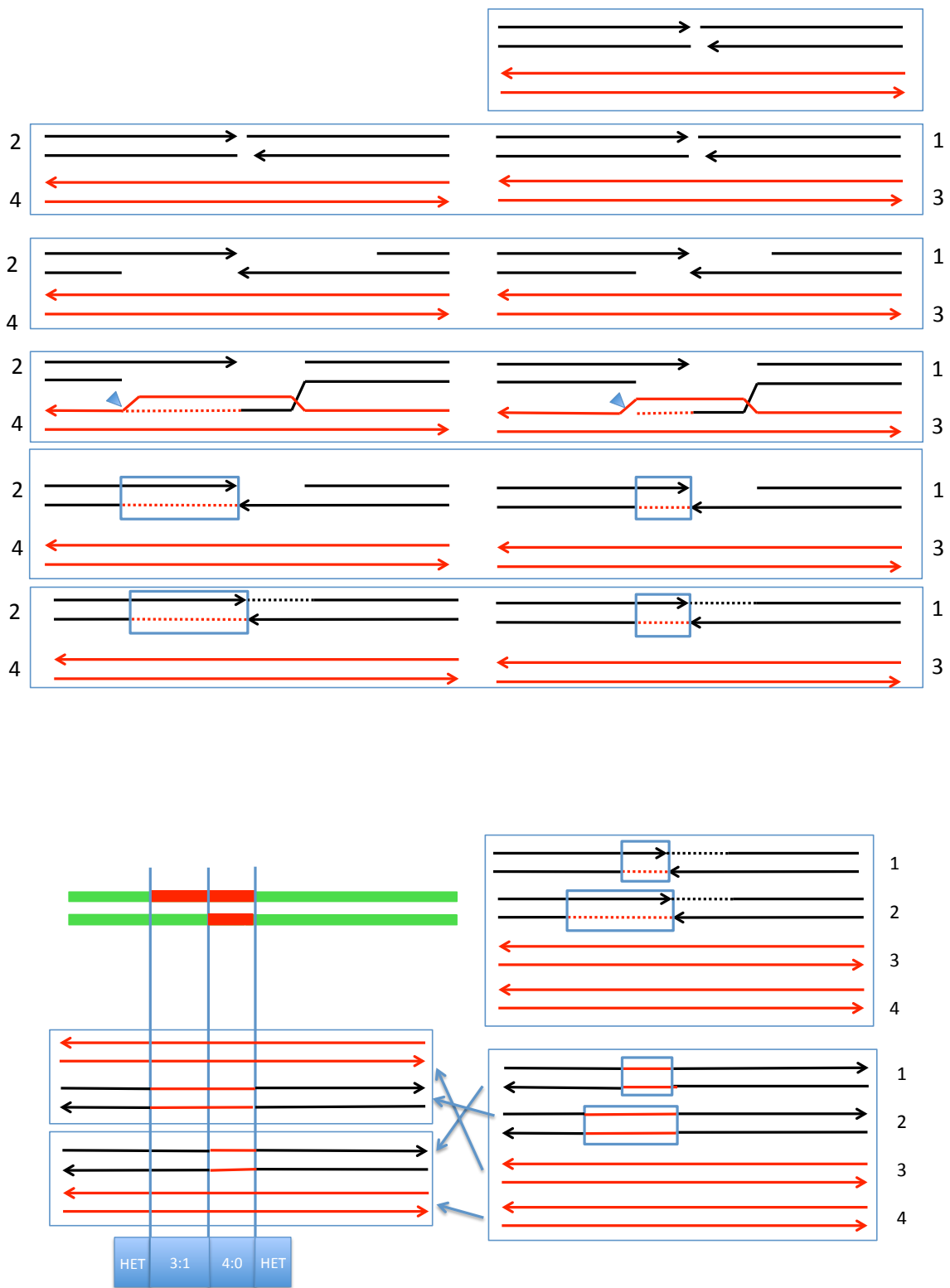

Figure S3. Description of Class C3 (C1,C2,C4) events. In Class C events, there is a 3:1/4:0 or a 1:3/0:4 hybrid conversion tract unassociated with a crossover. Such events can be explained as a consequence of the repair of two DSBs by the SDSA pathway. The conversion tracts associated with the repair events have different lengths.

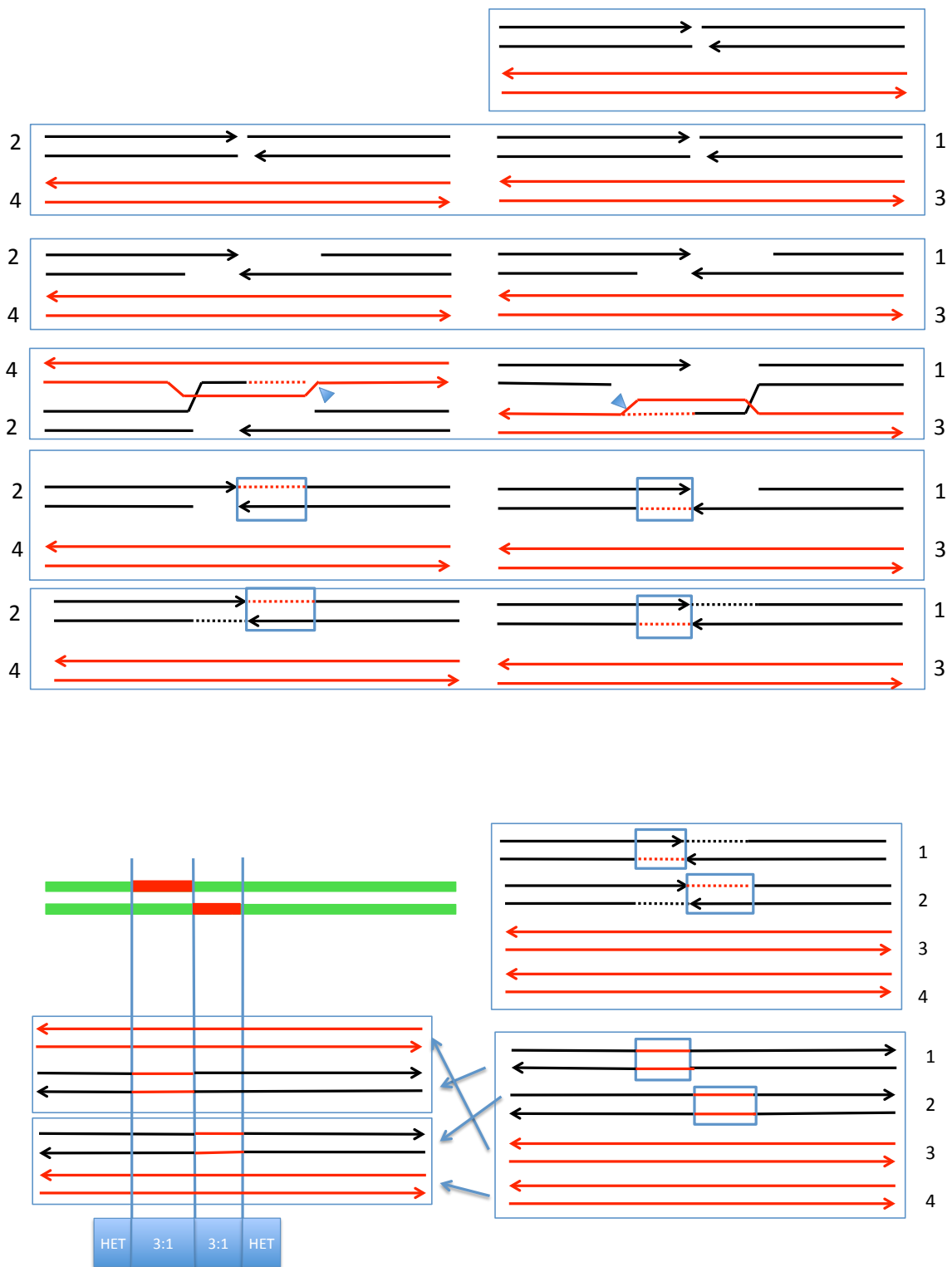

Figure S4. Description of Class D1 event. In this class, there is a 3:1 conversion tract that is split between the two sectors and that is unassociated with a crossover. Such events can be explained as a consequence of the repair of two DSBs by the SDSA pathway. The conversion tracts are produced by strand invasions that occur on different sides of the DSBs.

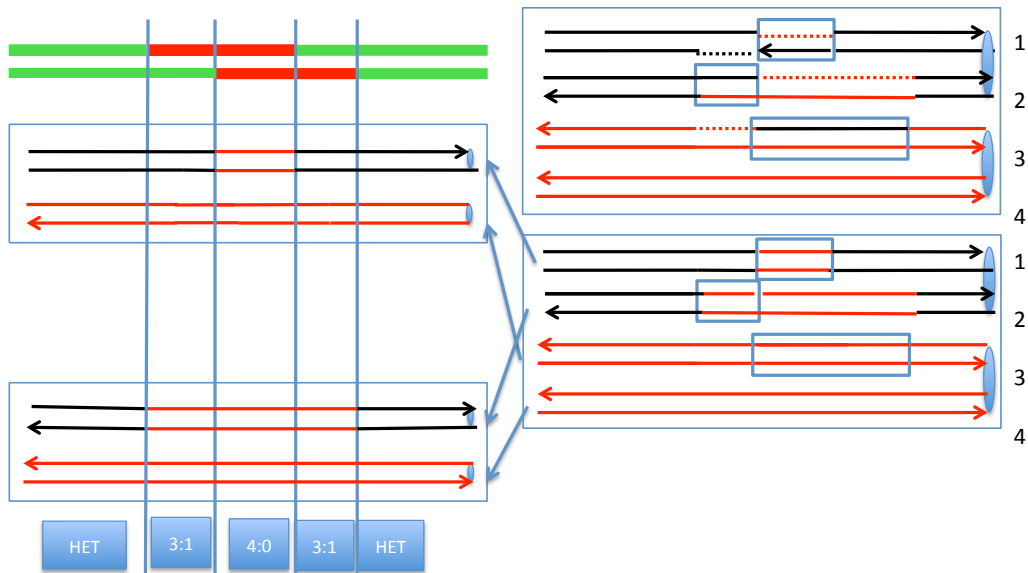
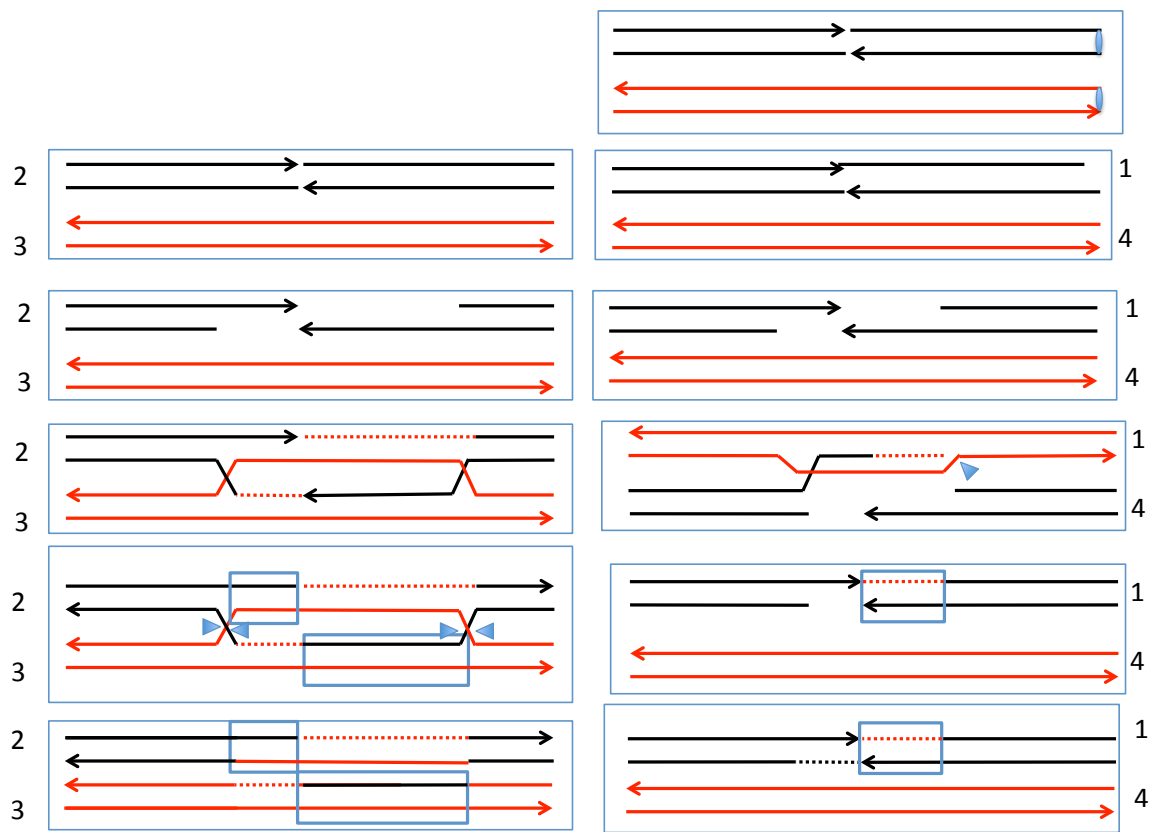

Figure S5. Description of Class E1 (E2) events. In Class E events, there is a 3:1/4:0/3:1 or a 1:3/0:4/1:3 hybrid conversion tract unassociated with a crossover. Such events can be explained as a consequence of the repair of two DSB, one by the SDSA pathway and one involving a double Holliday junction. The conversion tracts associated with the repair events have different lengths.

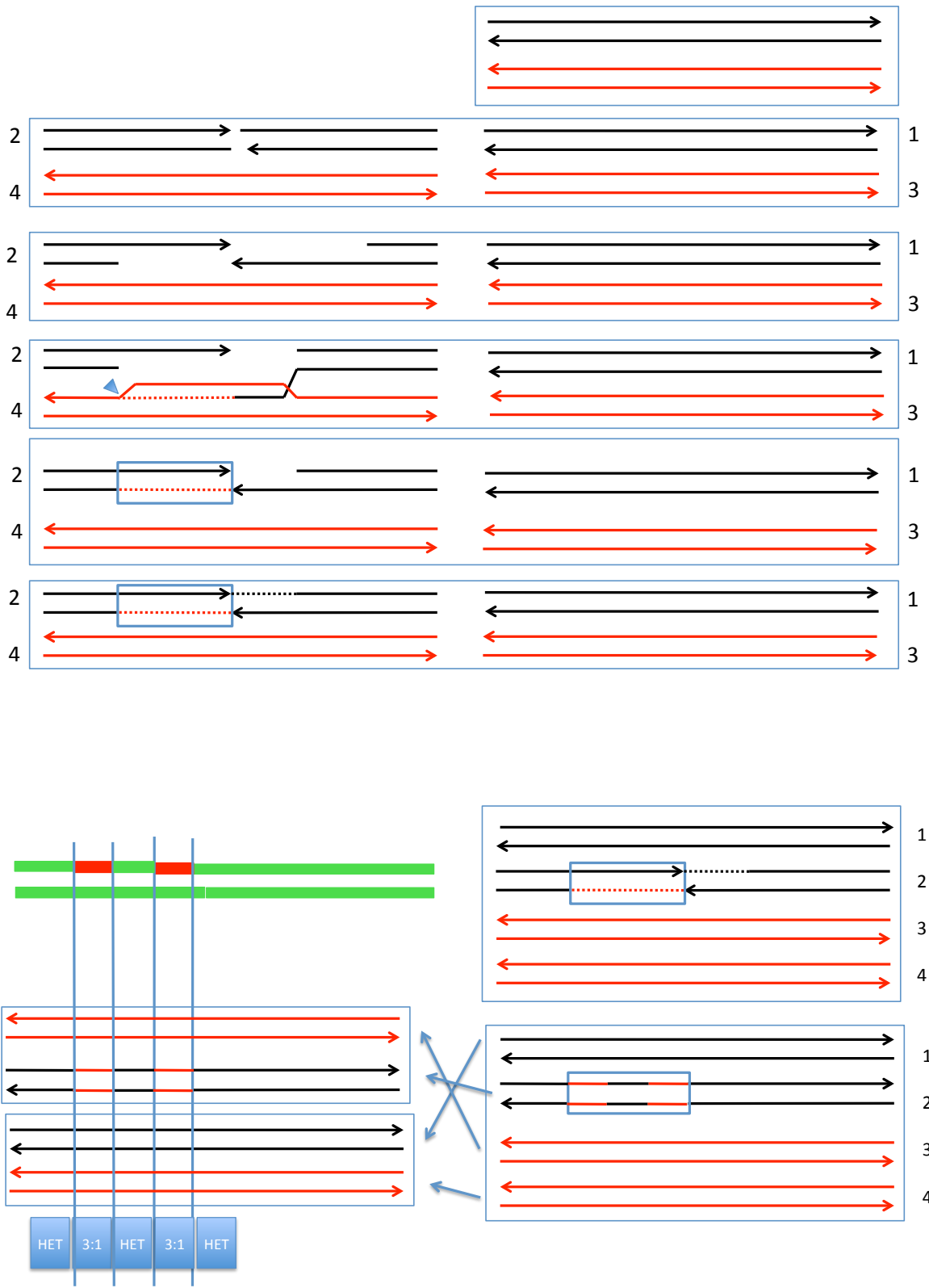

Figure S6. Description of Class F1 (F2) events. In these events, there are two discontinuous 3:1 or 1:3 conversion tracts unassociated with a crossover. Such events can be explained as a consequence of repair of one G2 DSB by the SDSA pathway. The mismatches in the resulting heteroduplex are repaired in a “patchy” manner as shown.

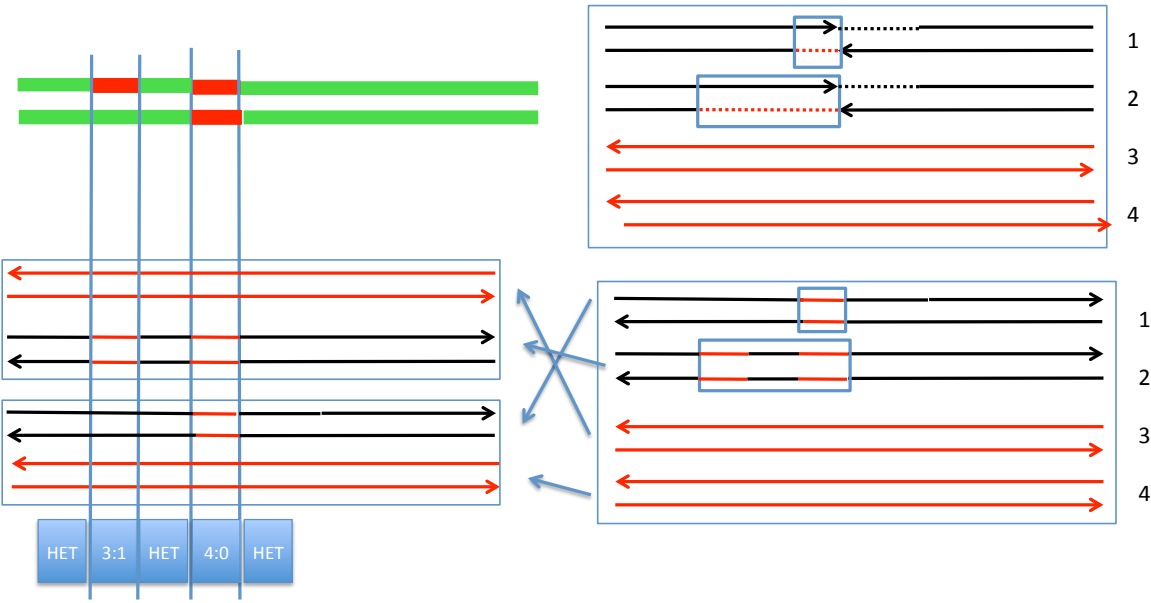
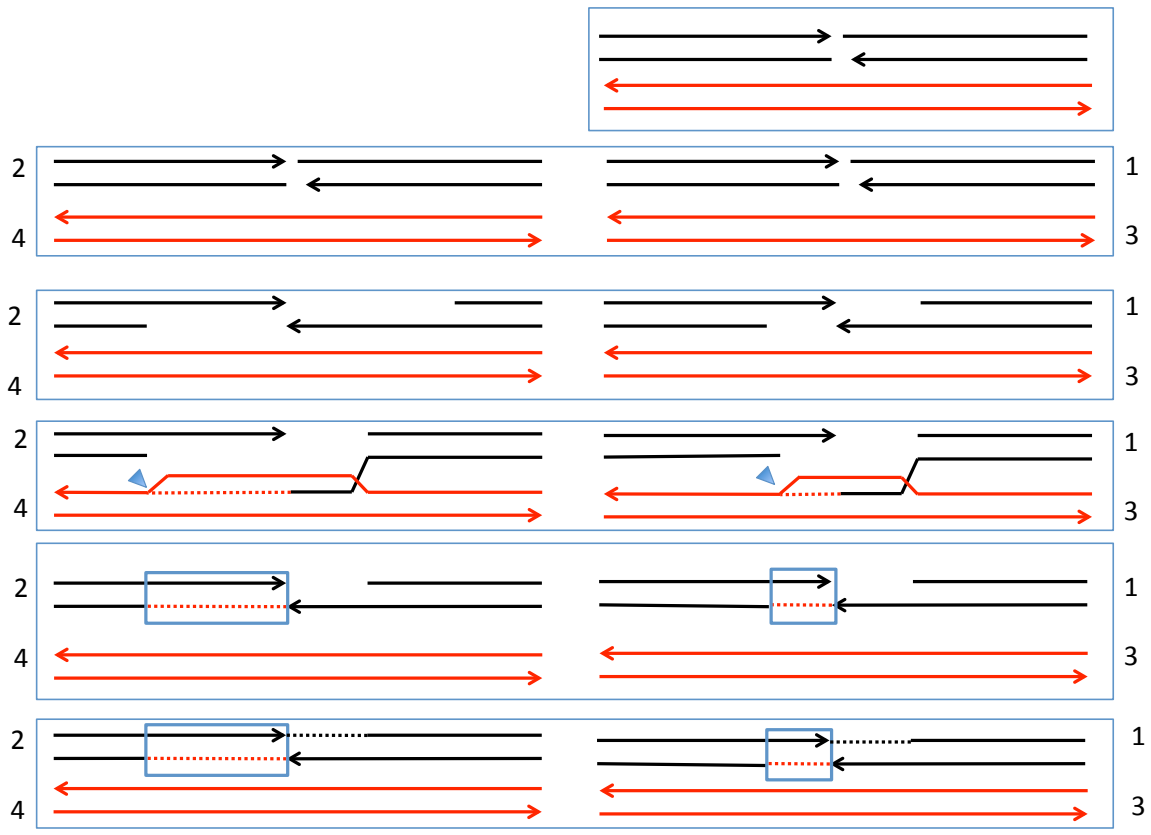

Figure S7. Description of Class F3 event. In this class, there is a 4:0 conversion event separated by a heterozygous segment from a 3:1 conversion tract; these conversion events are unassociated with a crossover. Such events can be explained as a consequence of the repair of two DSBs by the SDSA pathway. The conversion tracts associated with the repair events have different lengths, and the mismatches in one of the conversion tracts are repaired in a “patchy” manner.

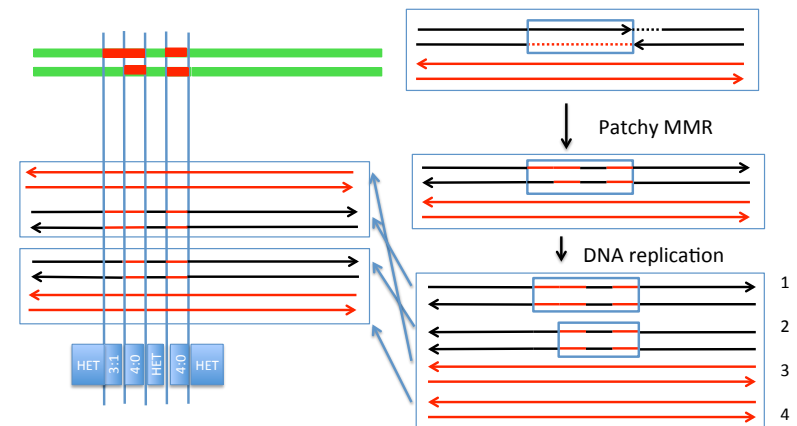
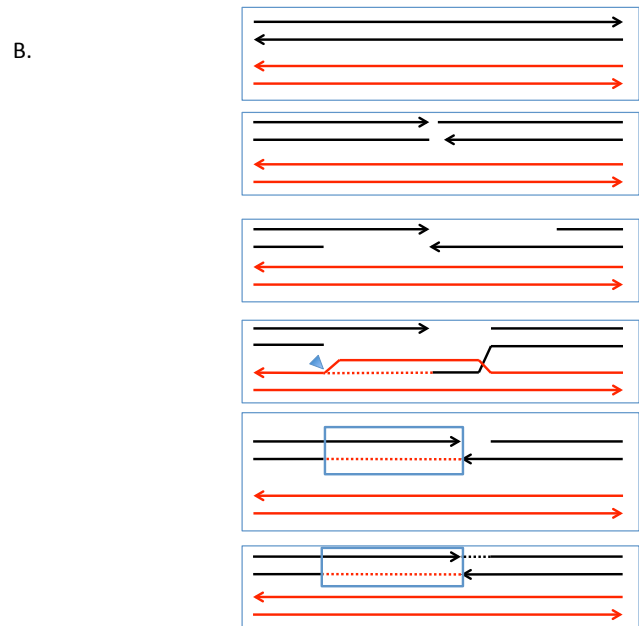
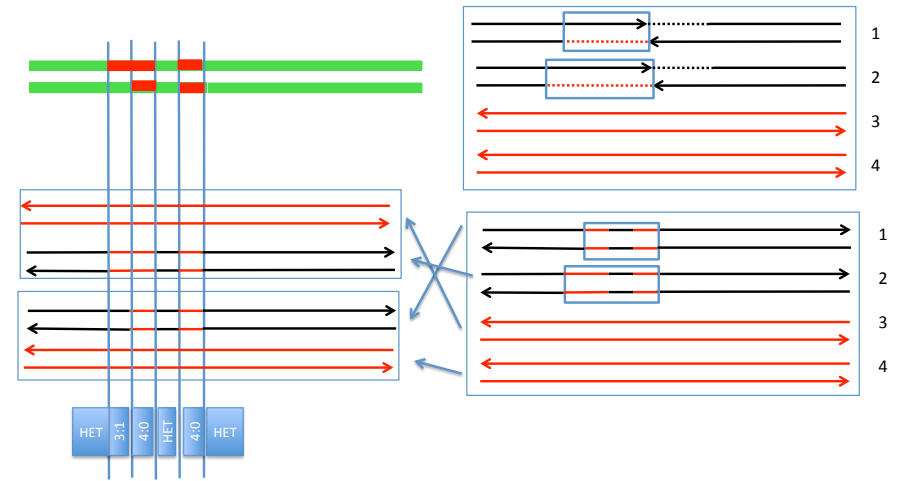
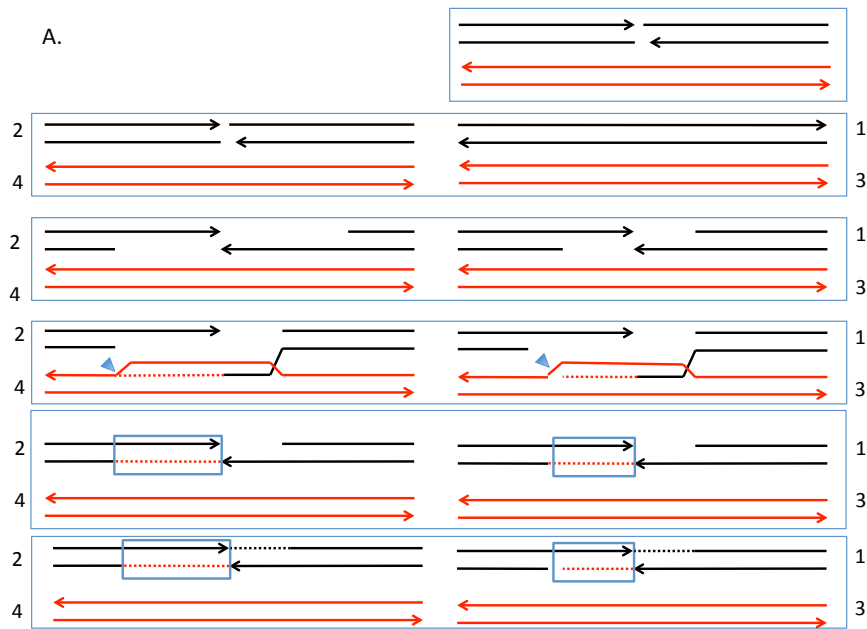

Figure S8. Generation of Class F4 by two different mechanisms. In Class F4, there is a 3:1/4:0 conversion tract separated from a second 4:0 tract by a heterozygous segment. In Fig. S10A, we show this pattern generated by the repair of two DSBs using the SDSA pathway. The heteroduplex tracts are of different lengths and are repaired in a “patchy” manner. In Fig. S10B, we show Class F4 as generated by repair of a single G1 DSB. Mismatches in the resulting heteroduplex are repaired in a “patchy” manner in G1 with one segment containing unrepaired mismatches. Replication of this molecule would produce the F4 pattern.

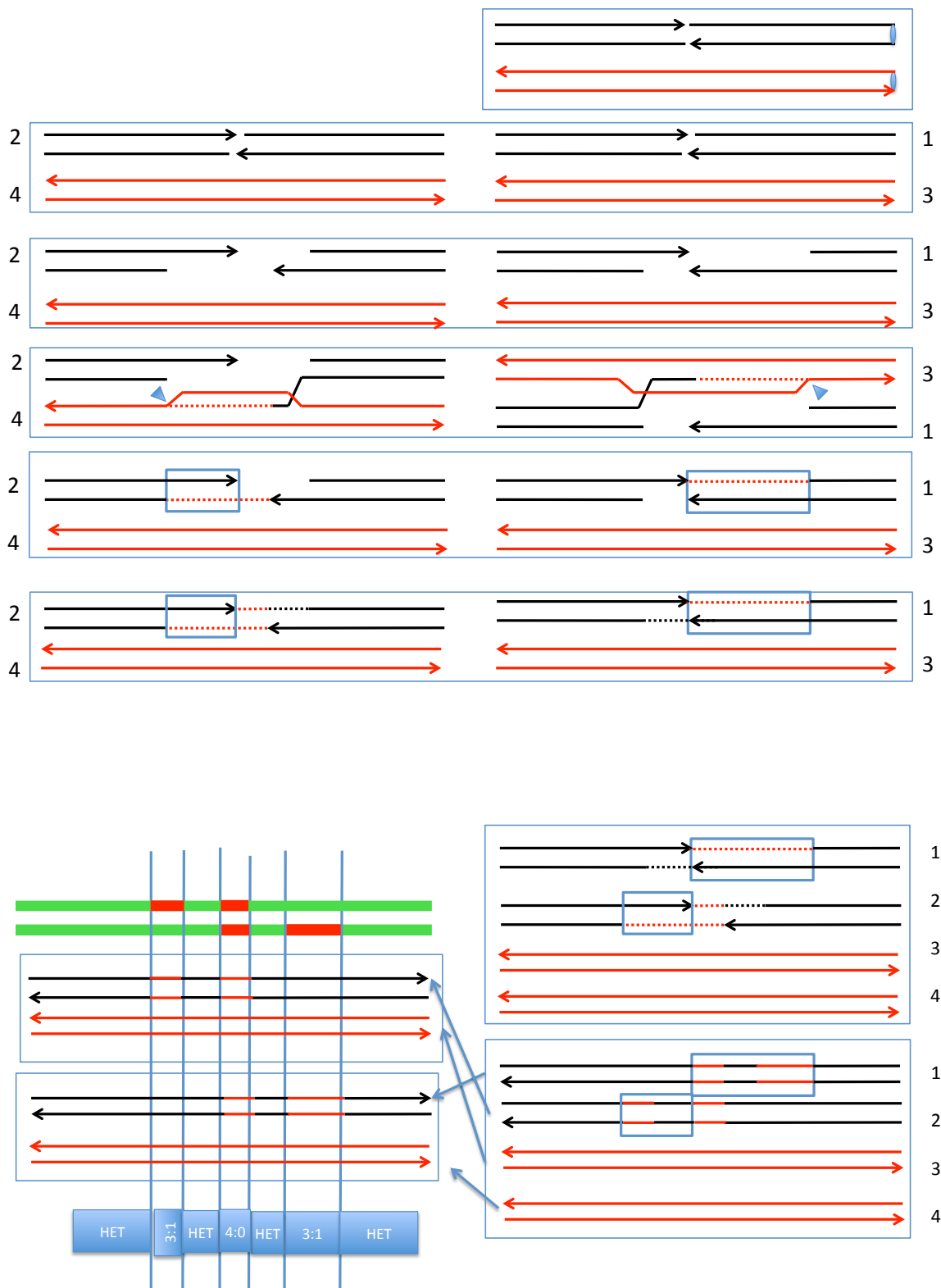

Figure S9. Description of the Class F5 event. In this event, there is a complex conversion tract unassociated with a crossover. This event can be explained as a consequence of the repair of two DSBs by the SDSA pathway; gap repair occurs with one of the broken chromosomes. The two resulting heteroduplexes undergo "patchy" repair of mismatches.

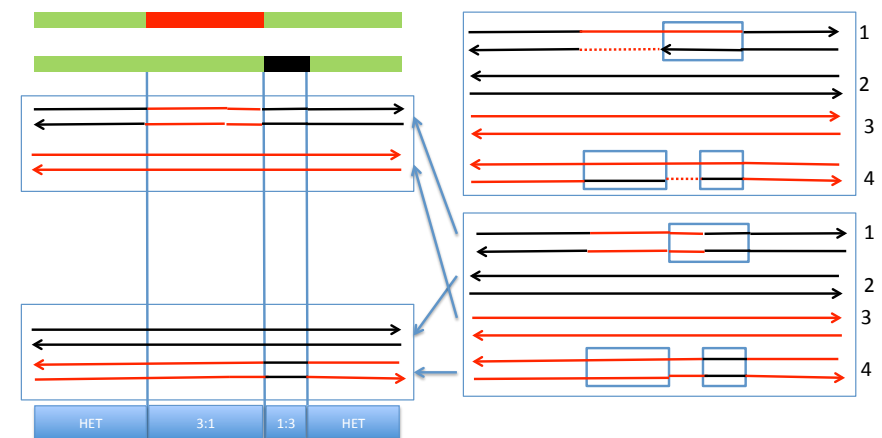
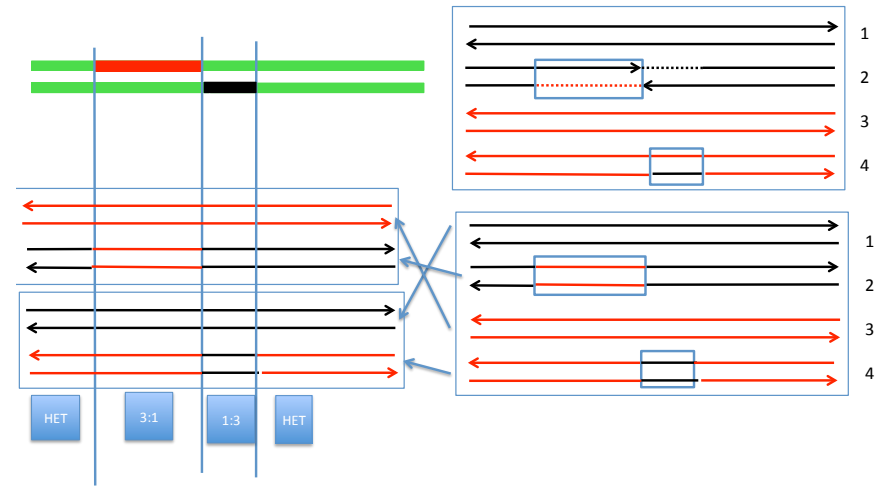
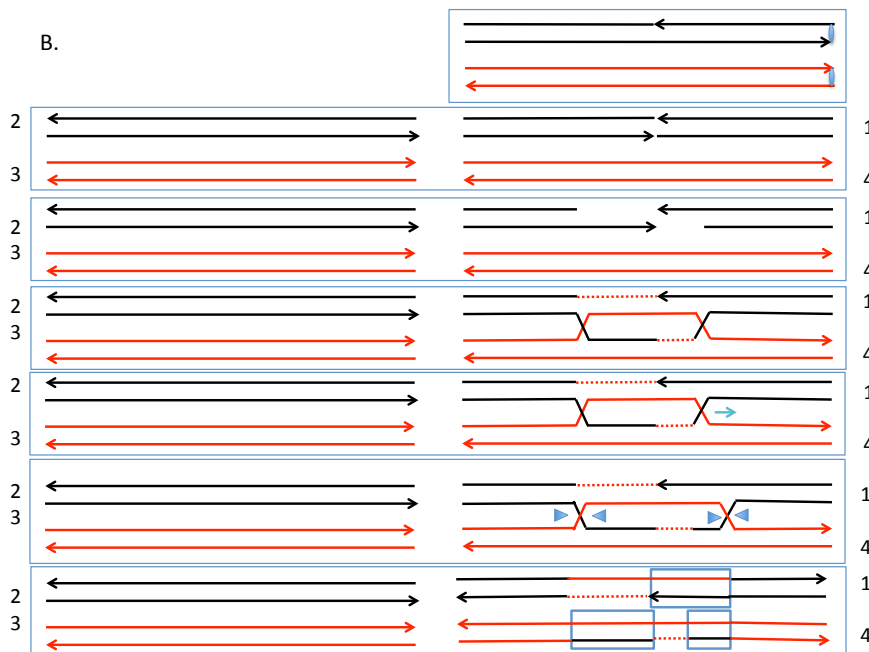
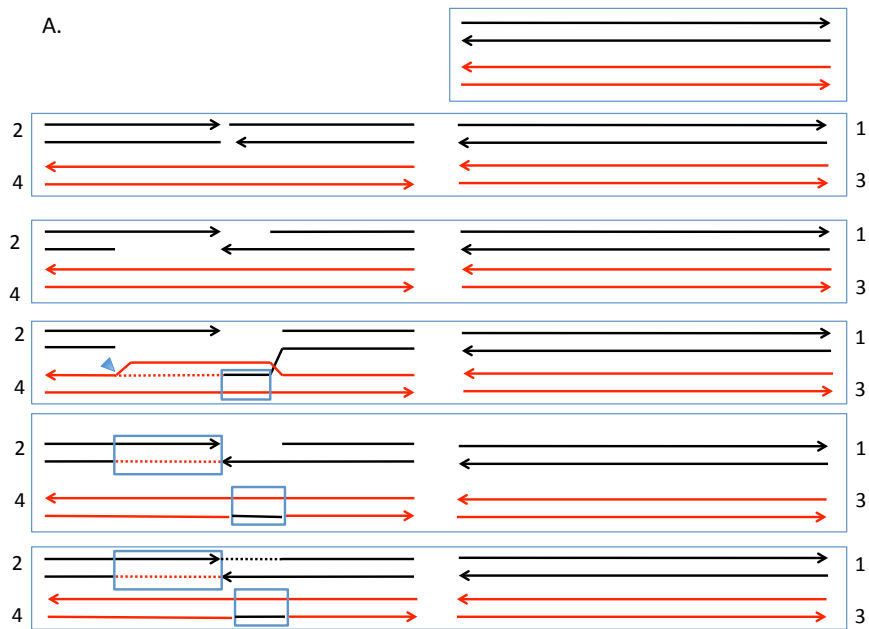

Figure S10. Generation of Class G1 by two different mechanisms. The Class G1 event has adjacent conversion tracts of 3:1 and 1:3 unassociated with a crossover.

A. In this model, the G1 event is produced by two rounds of mismatch repair during SDSA, one associated with the invading strand, and a second after strand displacement.

B. In the second model, the event is produced by repair of mismatches in symmetric heteroduplexes produced by branch migration (DSBR pathway).

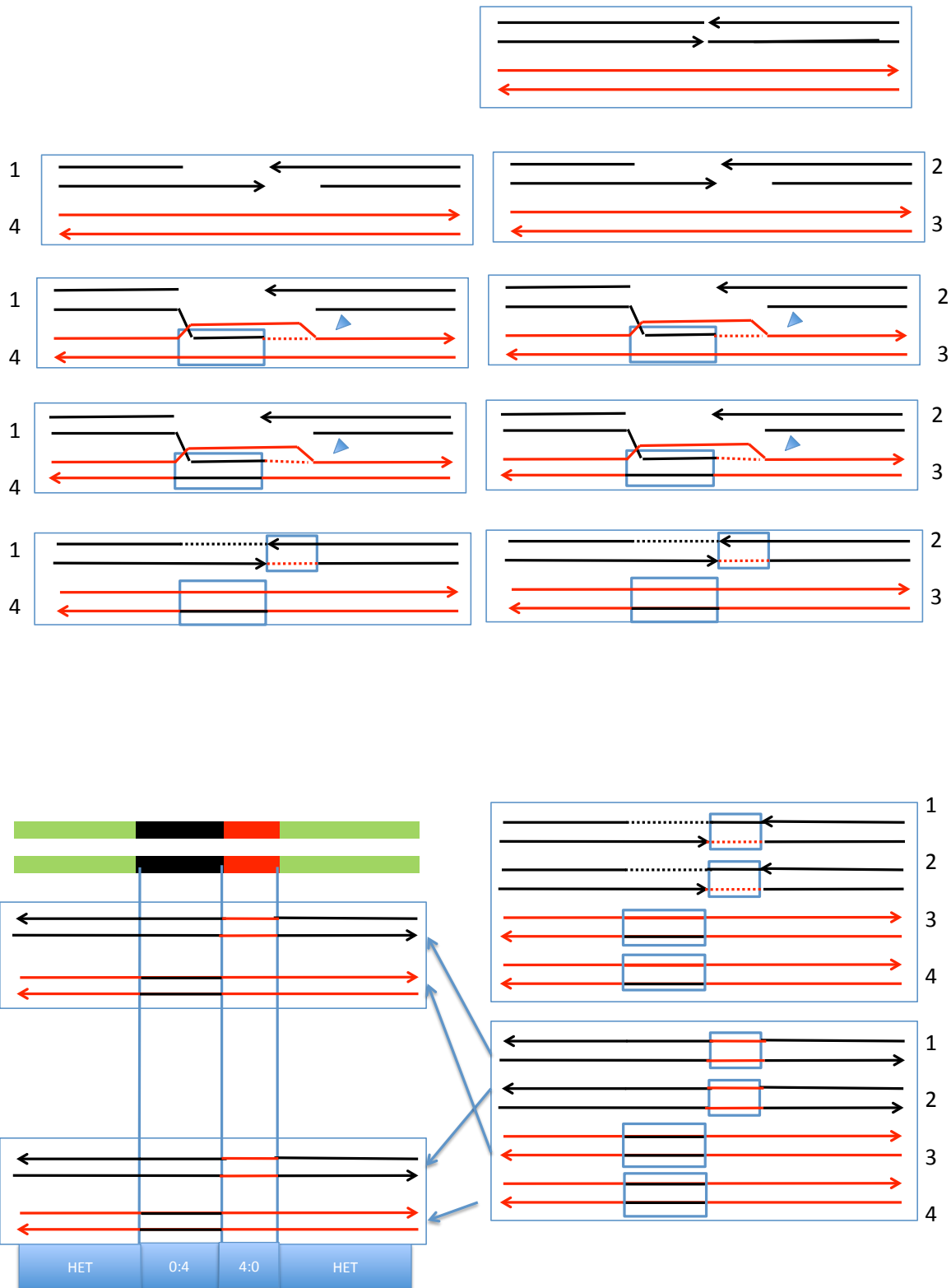

Figure S11. Description of the Class G2 event. In this event, there are two adjacent 4:0 and 0:4 conversion tracts unassociated with a crossover. This event can be explained as a consequence of the repair of two DSBs by the SDSA pathway; two cycles of mismatch repair occur for both SDSA events, similar to those shown in Fig. S10A.

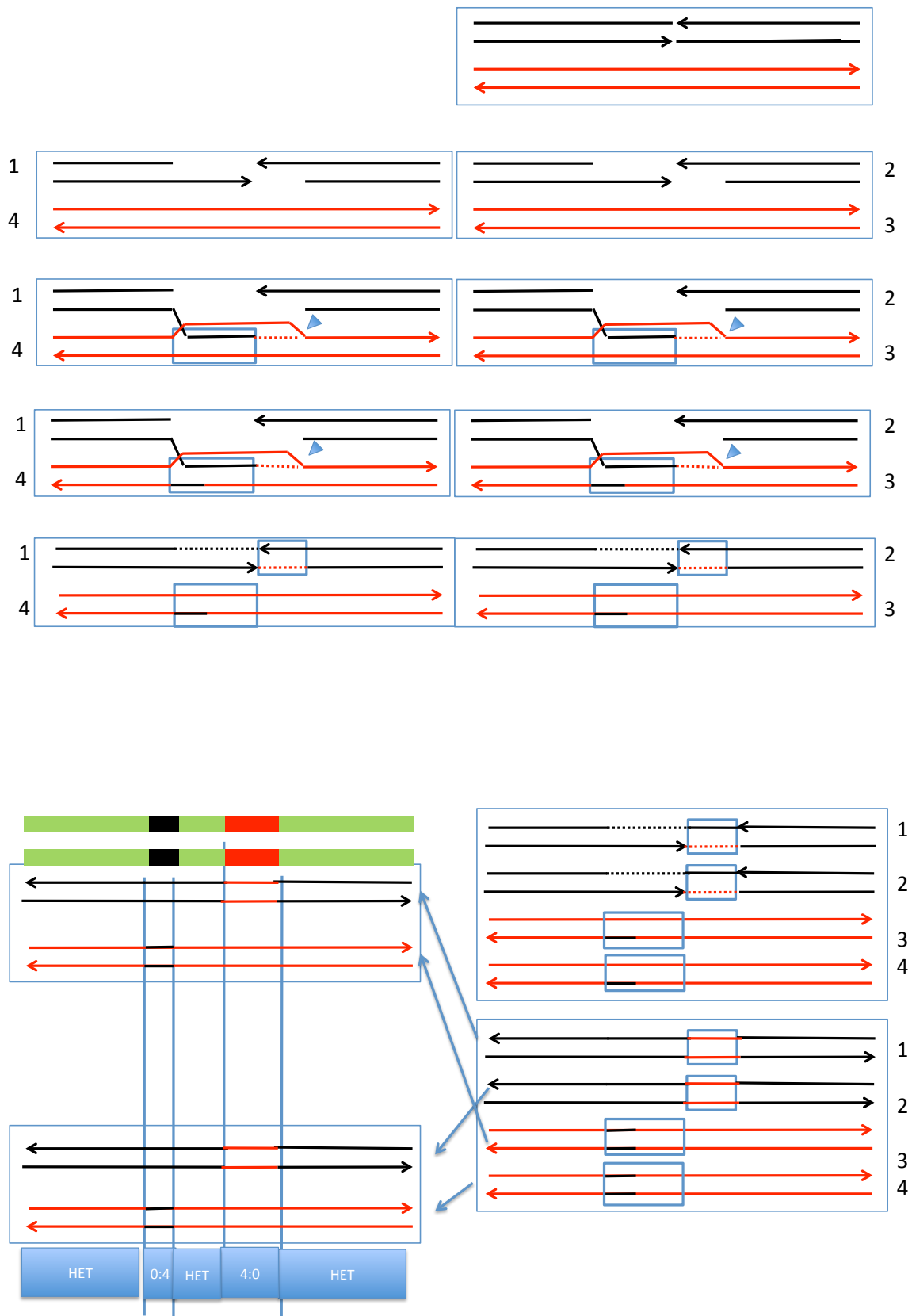

Figure S12. Description of the Class G3 event. In this event, there are 4:0 and 0:4 conversion tracts separated by heterozygous segments unassociated with a crossover. This event can be explained as a consequence of the repair of two DSBs by the SDSA pathway; two cycles of mismatch repair occur for both SDSA events, similar to those shown in Fig. S11. Mismatch repair in the first cycle is “patchy.”

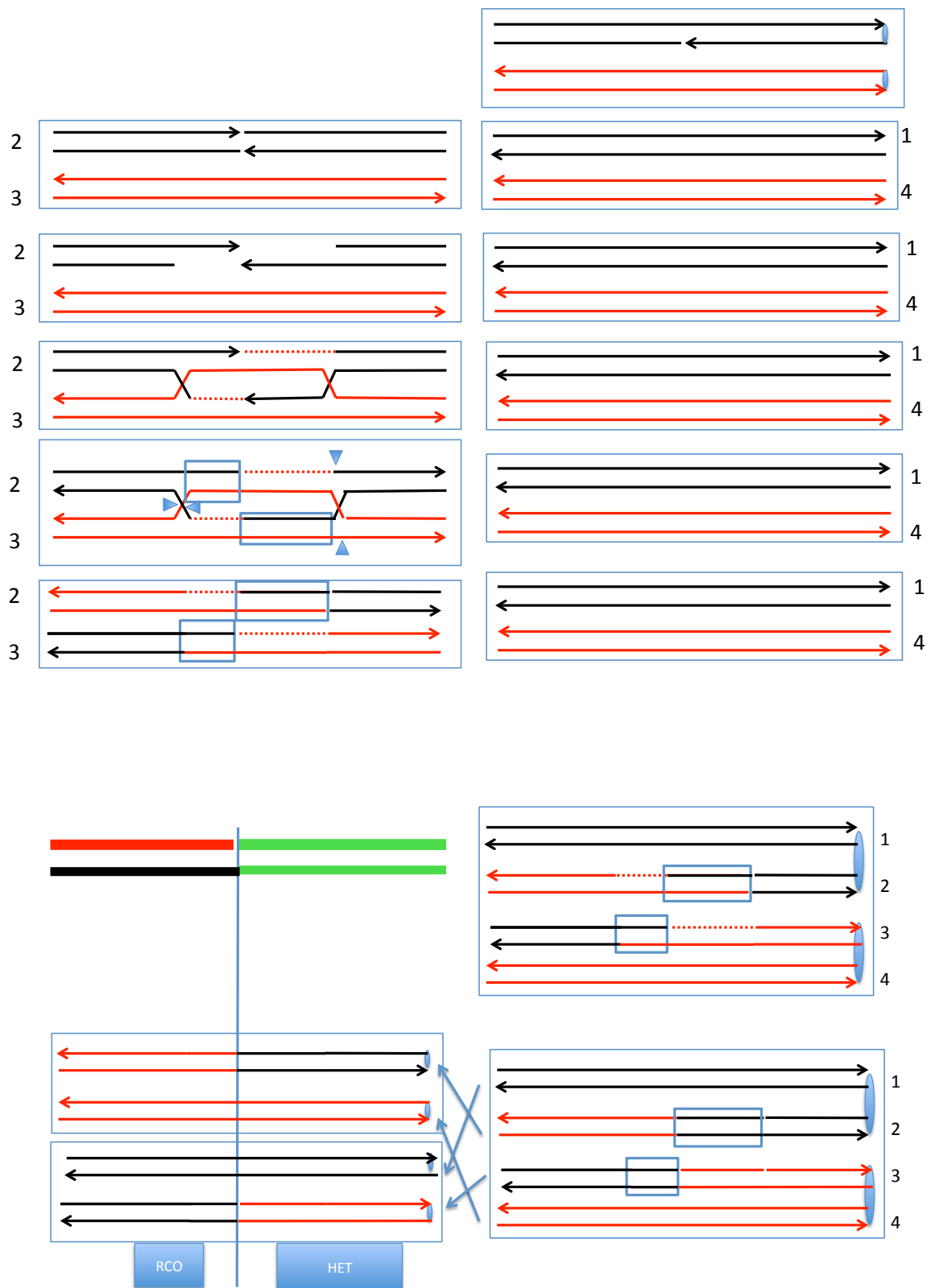

Figure S13. Description of the Class H1 event. In this event, there is a reciprocal crossover without a detectable associated conversion. This event can be explained as a consequence of the repair of a single DSB by the DSBR pathway. Mismatches in the heteroduplex regions are eliminated by restoration-type repair rather than conversion-type repair.

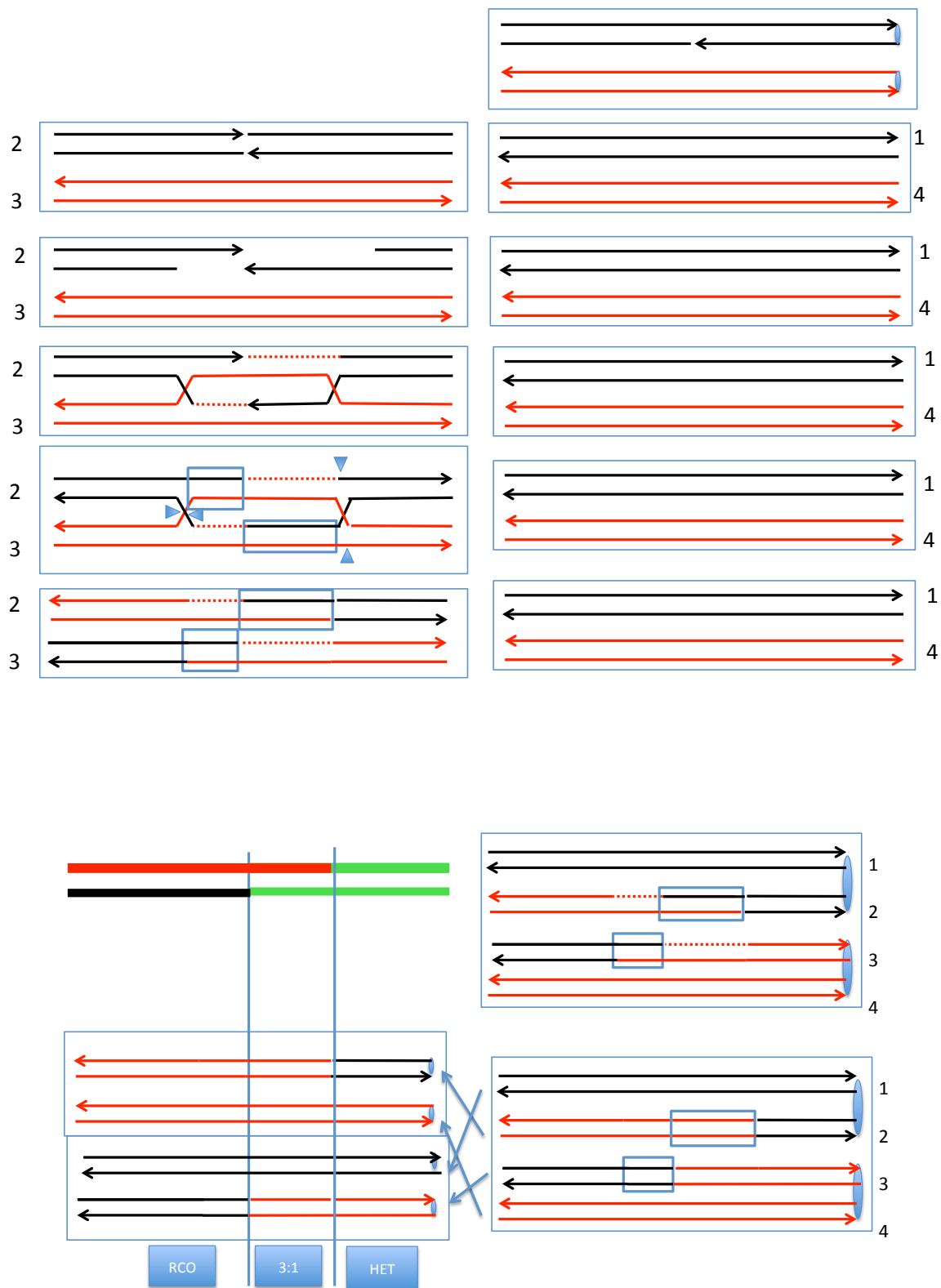

Figure S14. Description of the Class H2 event. In this event, there is a reciprocal crossover with an associated 3:1 conversion. This event can be explained as a consequence of the repair of a single DSB by the DSBR pathway. In one heteroduplex, mismatches are corrected by conversion-type repair and, in the other, by restoration-type repair.

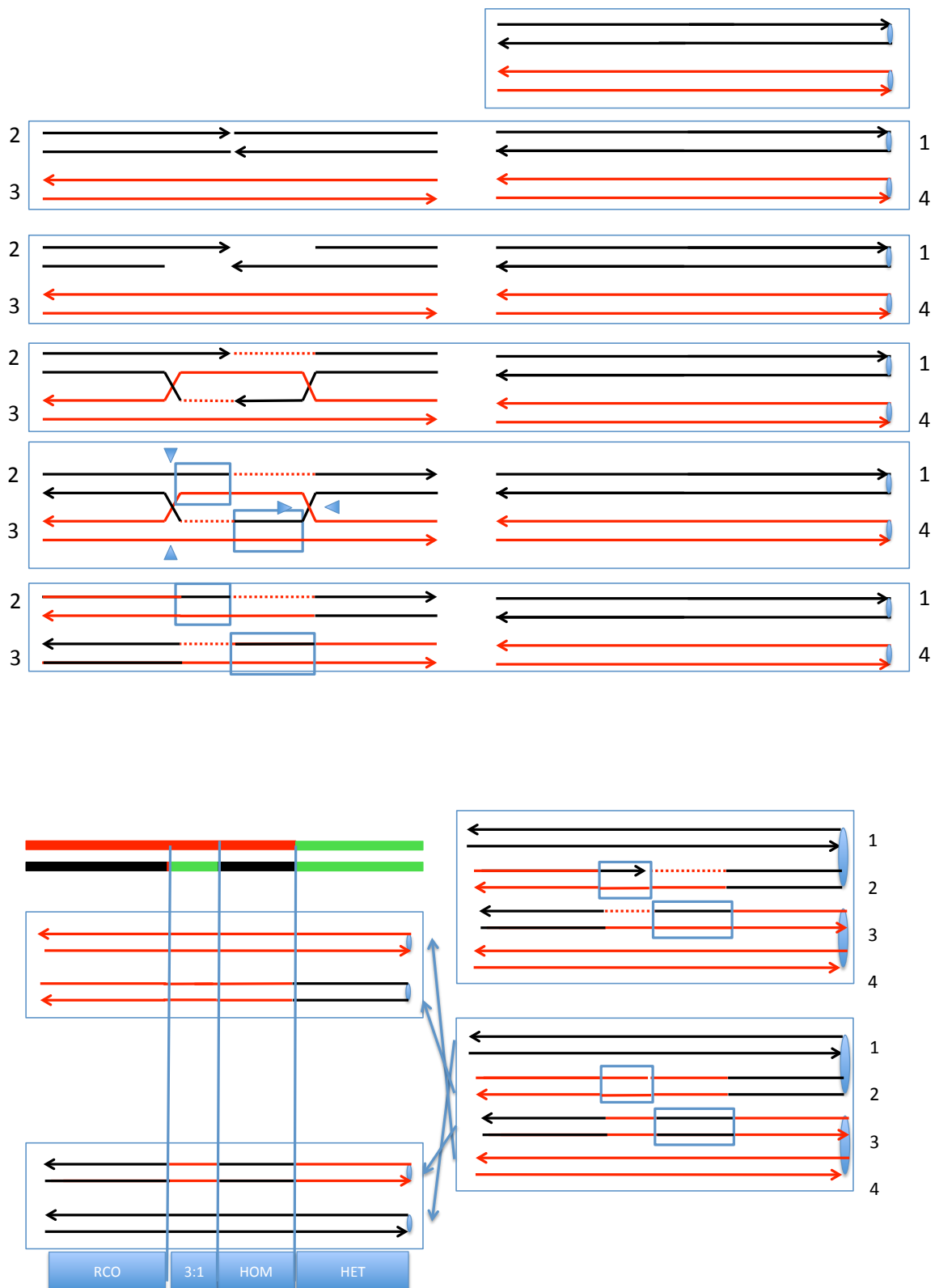

Figure S15. Description of the Class H3 event. In this event, there is a 3:1 conversion tract in the middle of the homozygous region. This event can be explained as a consequence of the repair of a single DSB by the DSBR pathway. The mismatches in one of the heteroduplexes are repaired by restoration-type repair, and mismatches in the other are repaired by conversion-type repair.

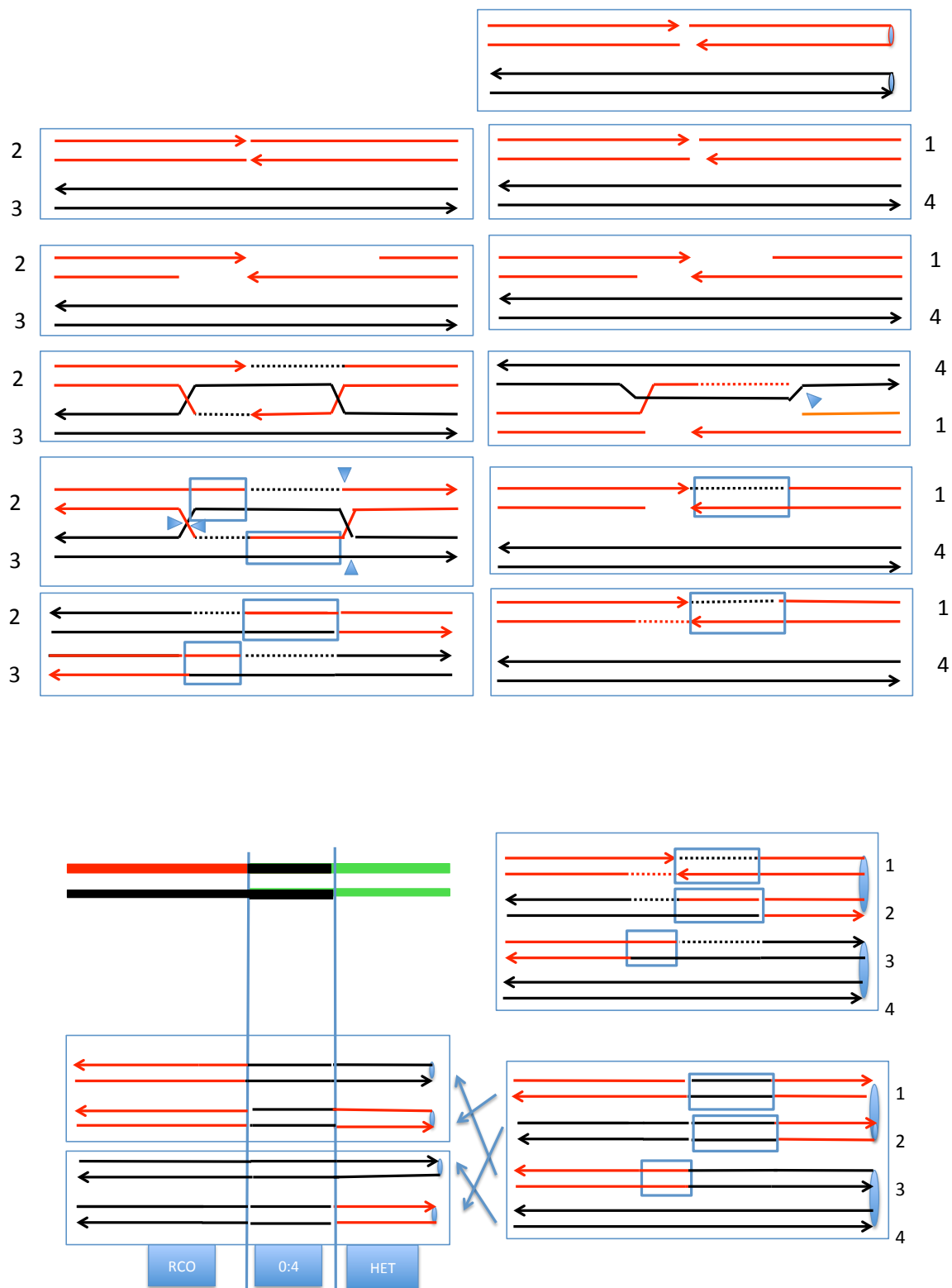

Figure S16. Description of the Class I1 event. In this event, the crossover is associated with a 0:4 conversion event. This event can be explained as a consequence of the repair of two DSBs, one by SDSA and the other by the DSBR pathway.

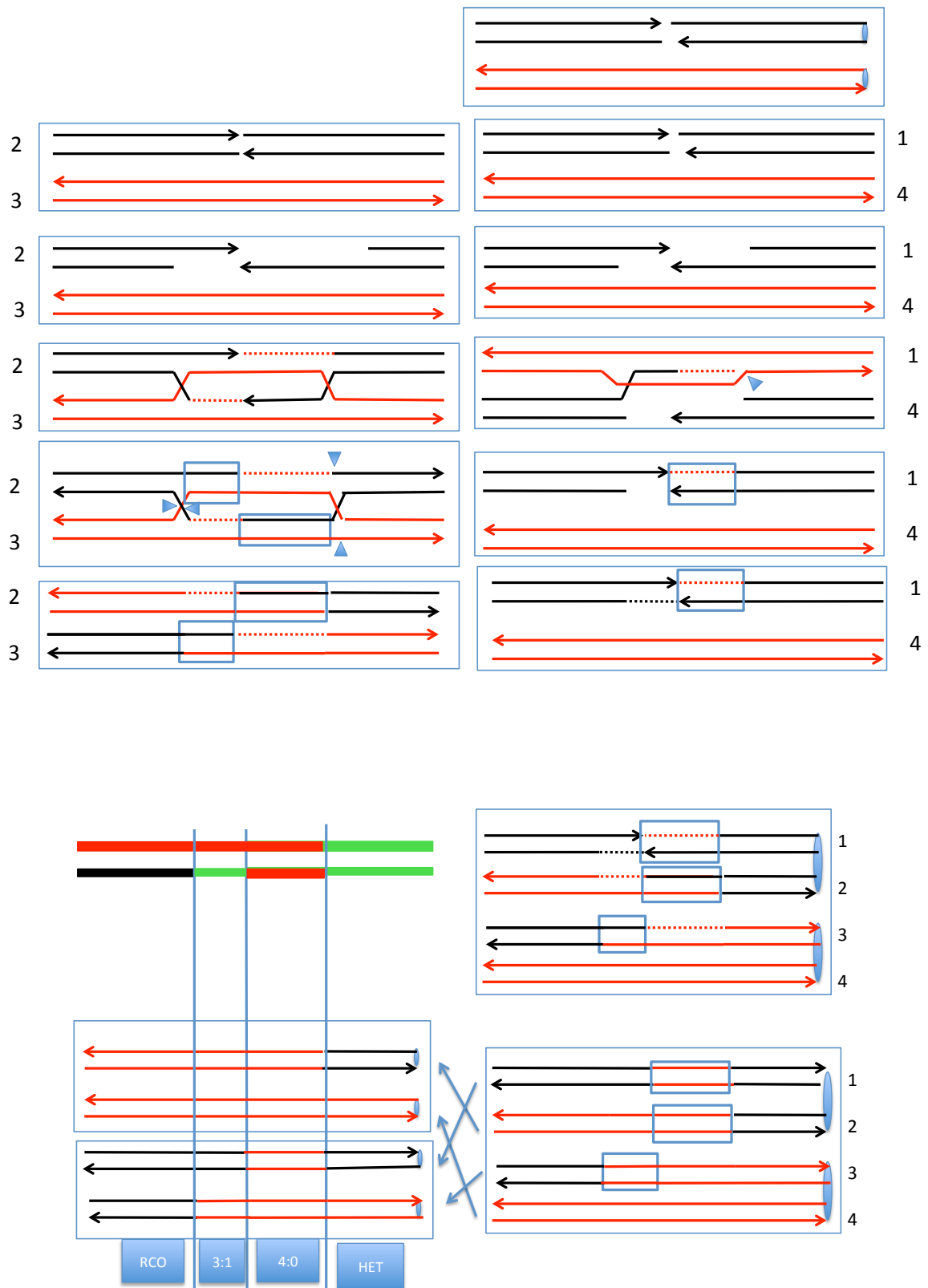

Figure S17. Description of the Class I2 (I3) events. In these events, the crossovers are associated with 3:1/4:0 or 1:3/0:4 hybrid conversion tracts. These events can be explained as a consequence of the repair of two DSBs, one by the SDSA pathway and one by the DSBR pathway.

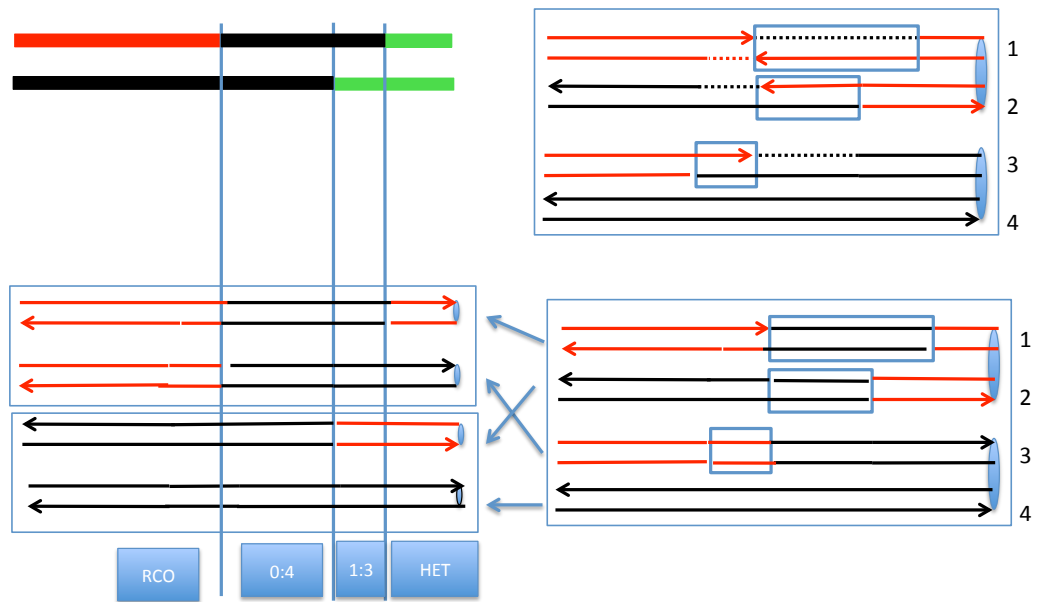
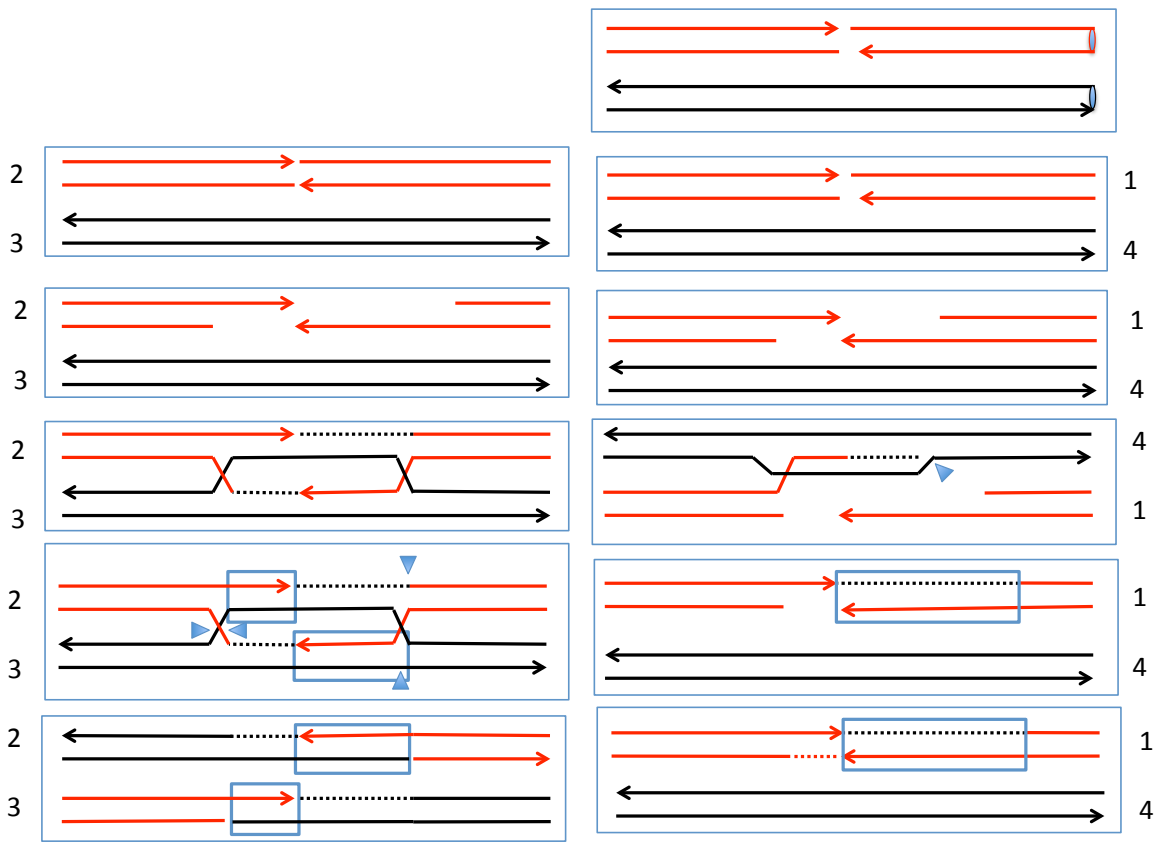

Figure S18. Description of the Class I4 event. This event is similar to that shown in Fig. S17 except the 0:4 portion of the hybrid tract is adjacent to the crossover. This event can be also explained as a consequence of the repair of two DSBs, one by the SDSA pathway and one by the DSBR pathway.

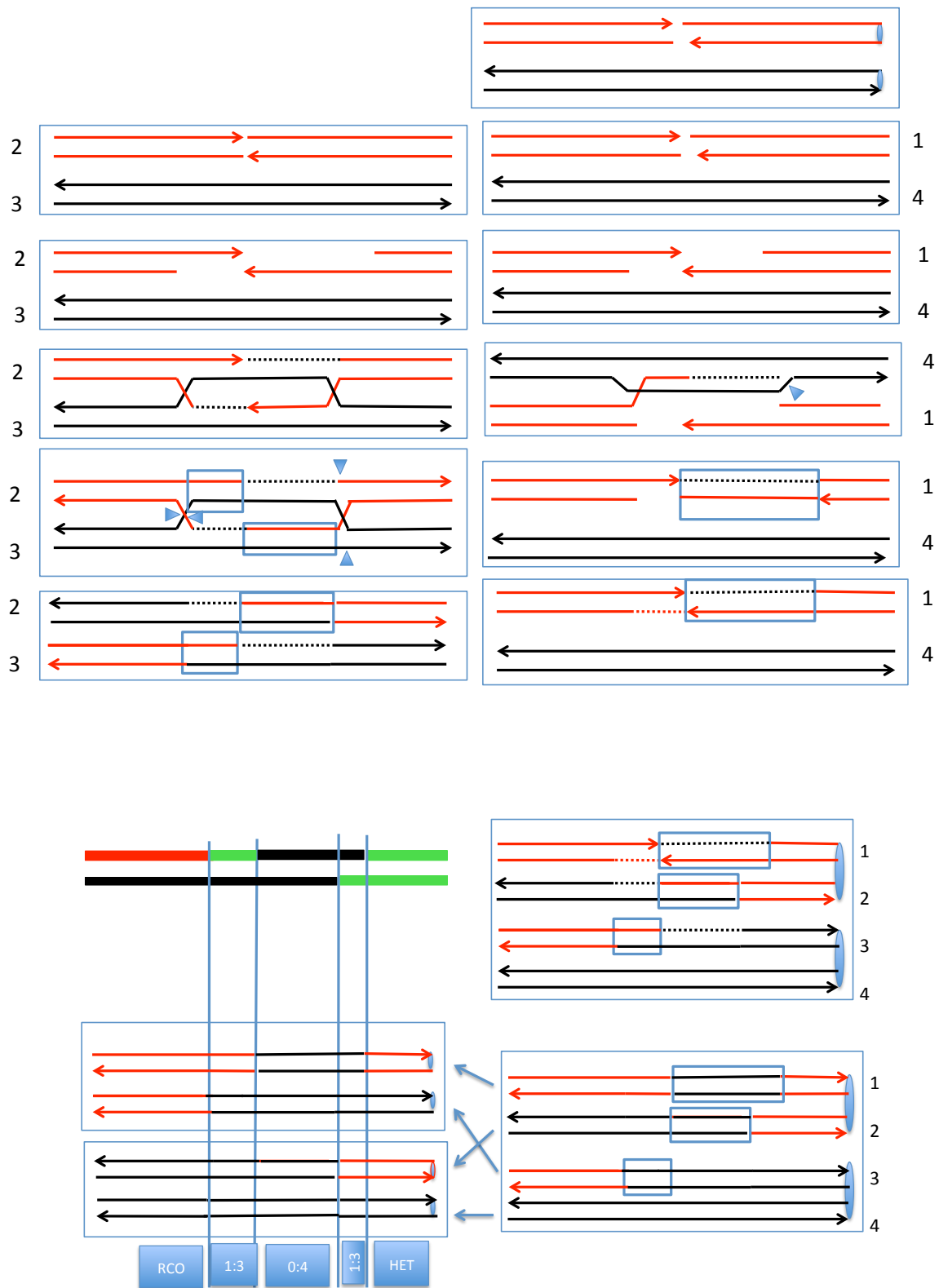

Figure S19. Description of the Class I6 (I5) events. In these events, the crossovers are associated with 3:1/4/0/3:1 or 1:3/0:4/1:3 hybrid conversion tracts. These events can be explained as a consequence of the repair of two DSBs, one by the SDSA pathway and one by the DSBR pathway.

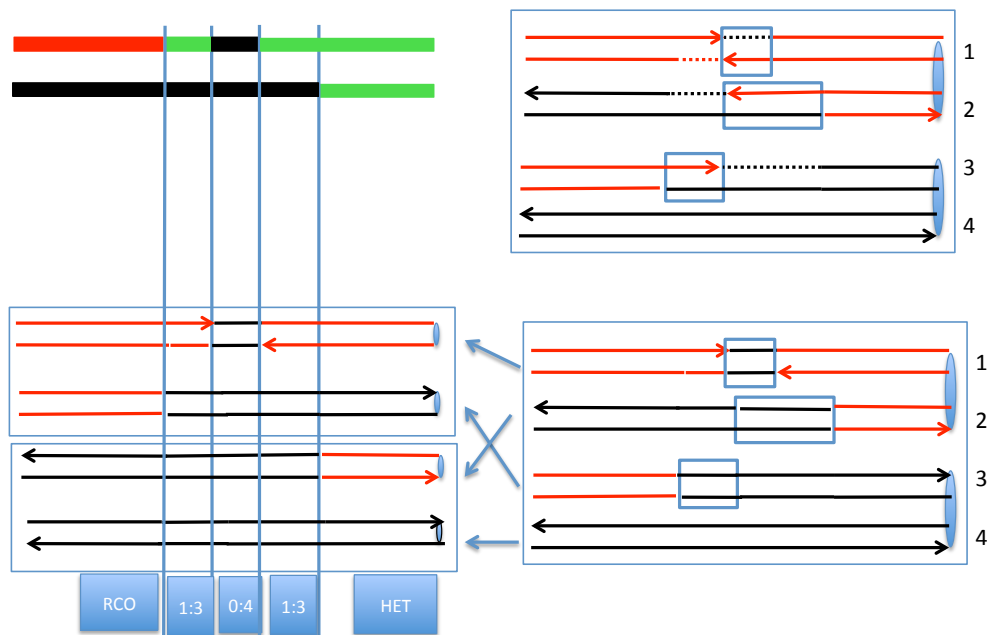
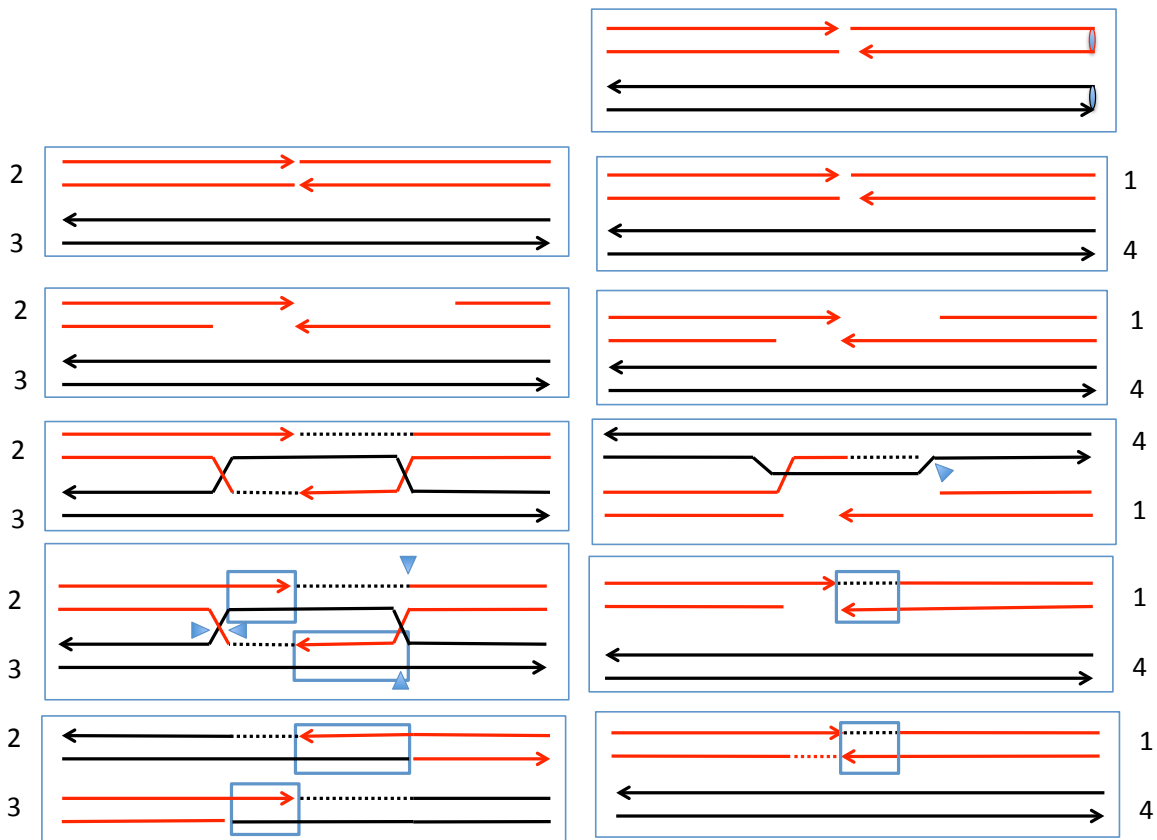

Figure S20. Description of the Class I7 (18) events. In these events, the crossovers are associated with 1:3/0:4/1:3 hybrid conversion tracts. These events can be explained as a consequence of the repair of two DSBs, one by the SDSA pathway and one by the DSBR pathway. The distinction between Fig. S19 and Fig. S20 is that the homozygous regions in the 1:3 tracts are located in *trans* in Fig. S19 and in *cis* in Fig. S20.

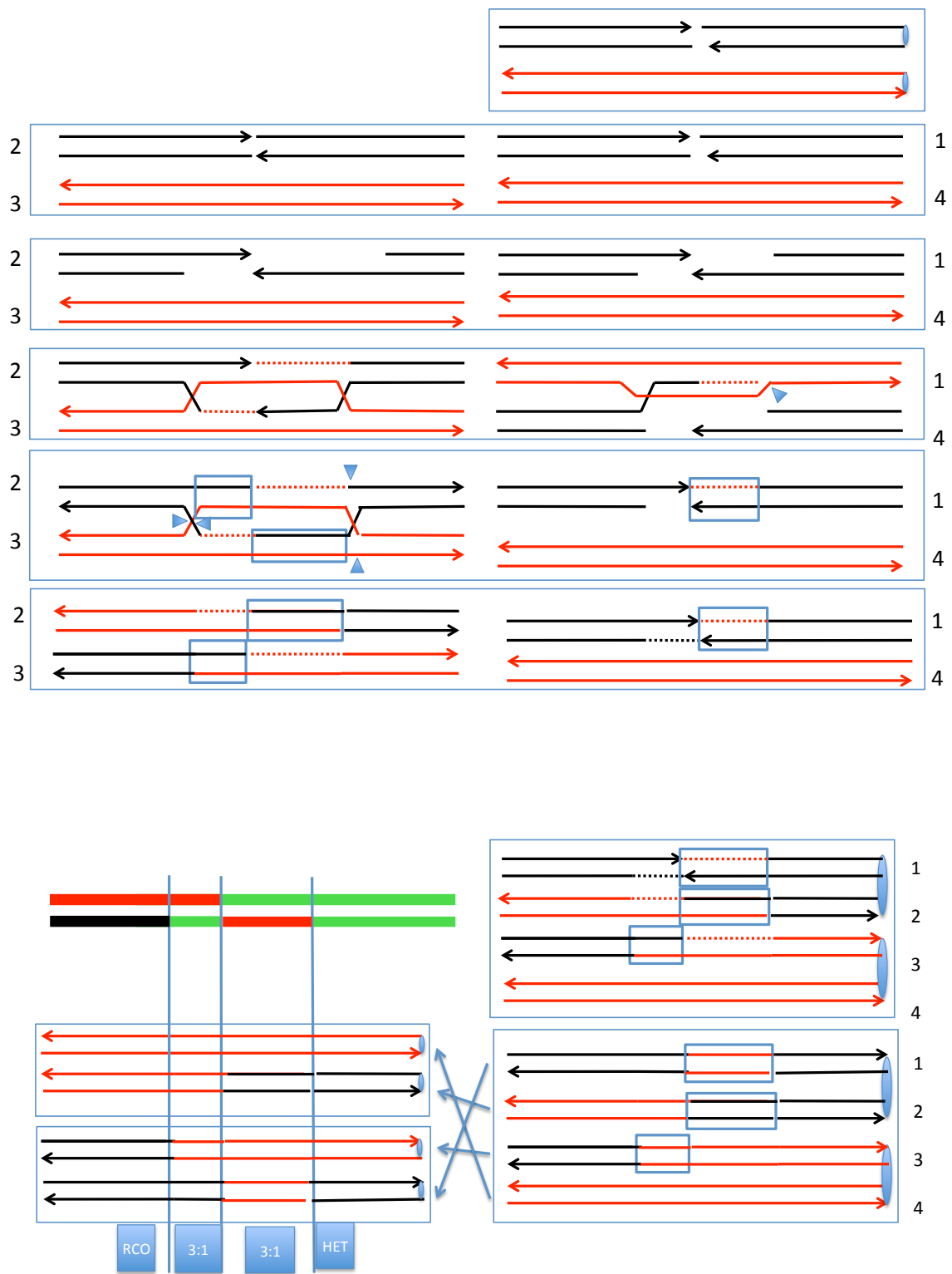

Figure S21. Description of the Class I9 event. In this event, the crossovers are associated with 3:1 conversion in which the homozygous region is split between the two sectors. These events can be explained as a consequence of the repair of two DSBs, one by the SDSA pathway and one by the DSBR pathway.

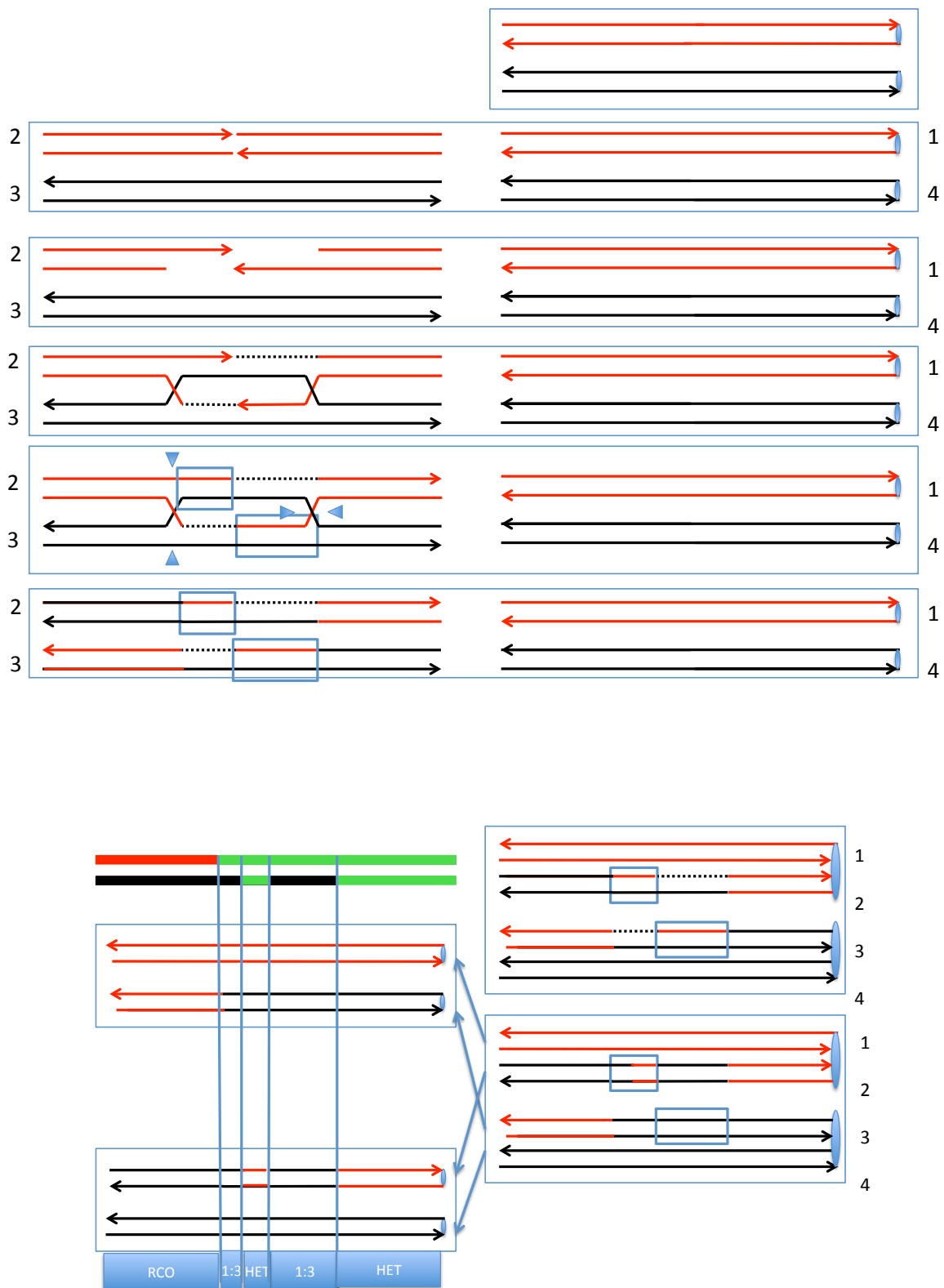

Figure S22. Description of the Class J1 event. In this event, the crossover is associated with a 1:3 conversion tract that is split by a region of heterozygosity. These events can be explained as a consequence of the repair of a single DSB by the DSBR pathway with “patchy” repair of mismatches in one of the heteroduplexes.

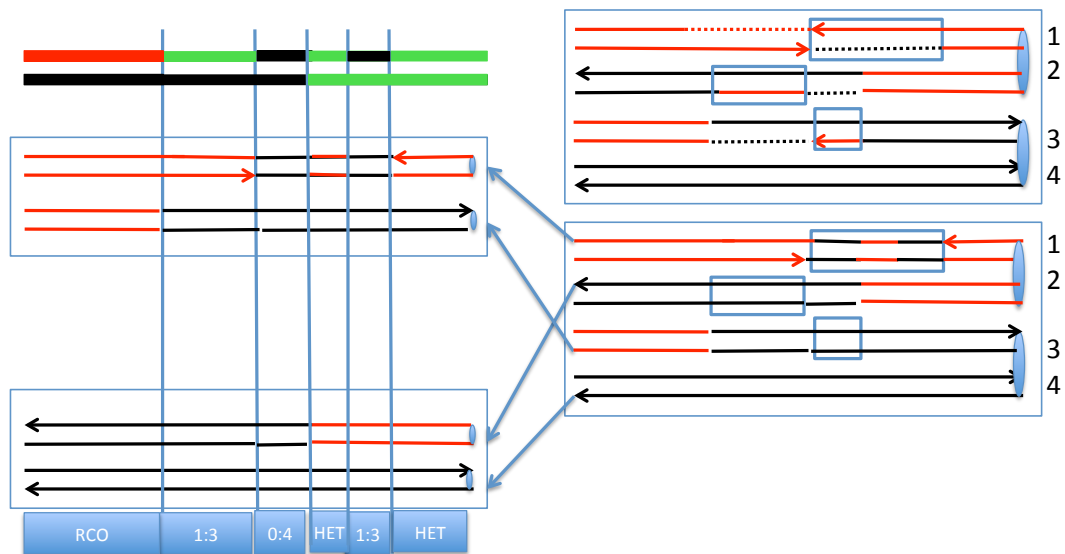
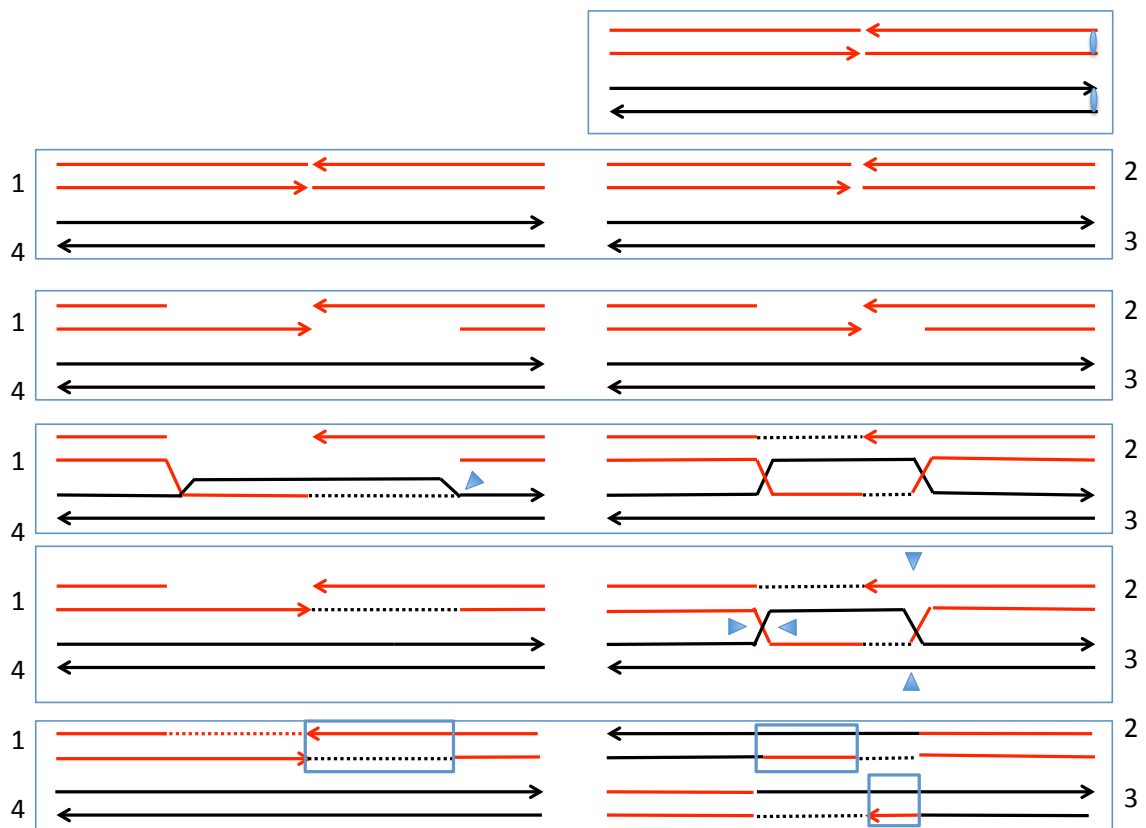

Figure S23. Description of the Class J2 event. In this event, the crossover is associated with a complex conversion tract. This event can be explained as a consequence of the repair of two DSBs, one by the DSBR pathway and one by the SDSA pathway. In addition, one of the heteroduplexes has "patchy" repair of mismatches.

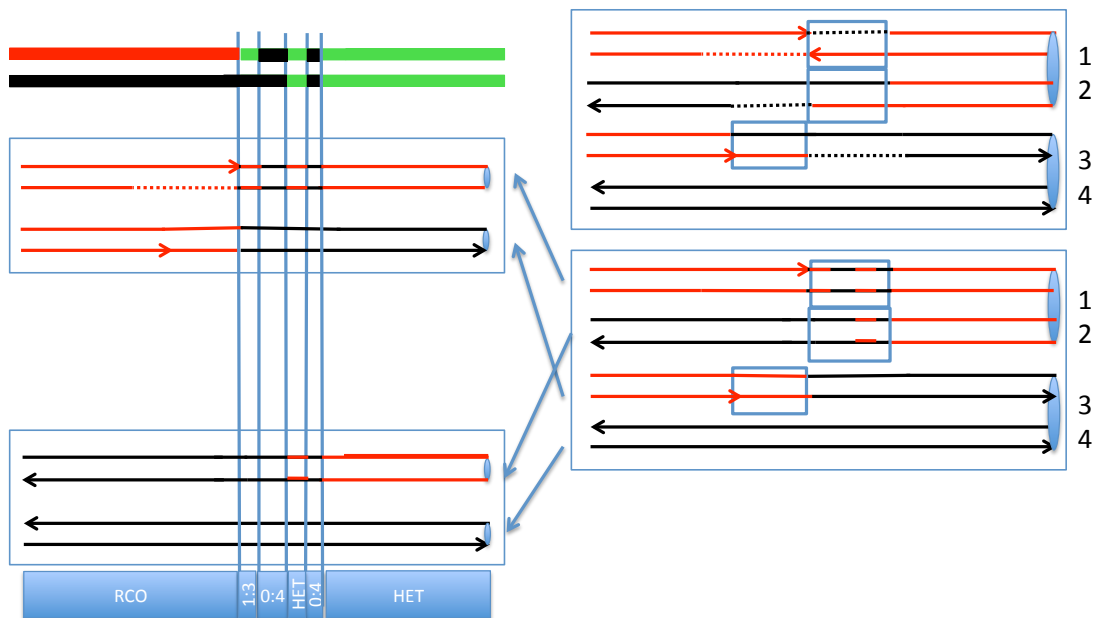
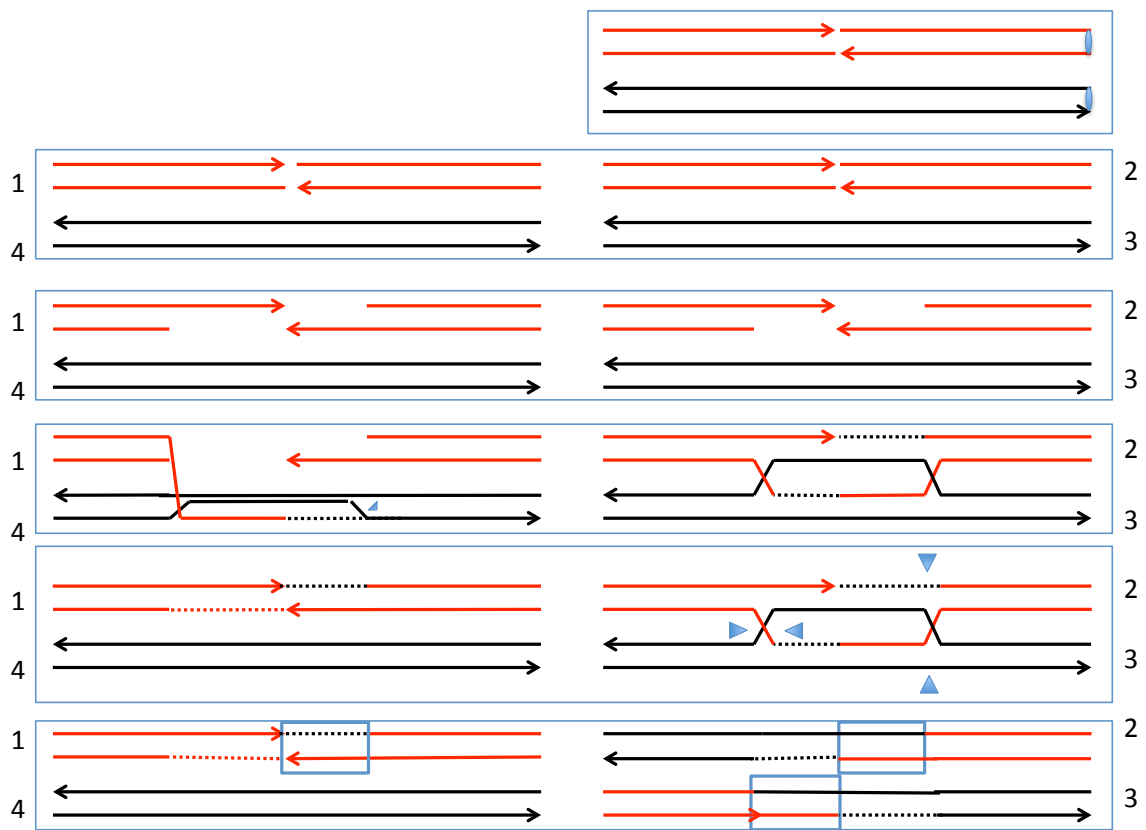

Figure S24. Description of the Class J3 event. In this event, the crossover is associated with a complex conversion tract. This event can be explained as a consequence of the repair of two DSBs, one by the DSBR pathway and one by the SDSA pathway. In addition, one of the heteroduplexes has “patchy” repair of mismatches.

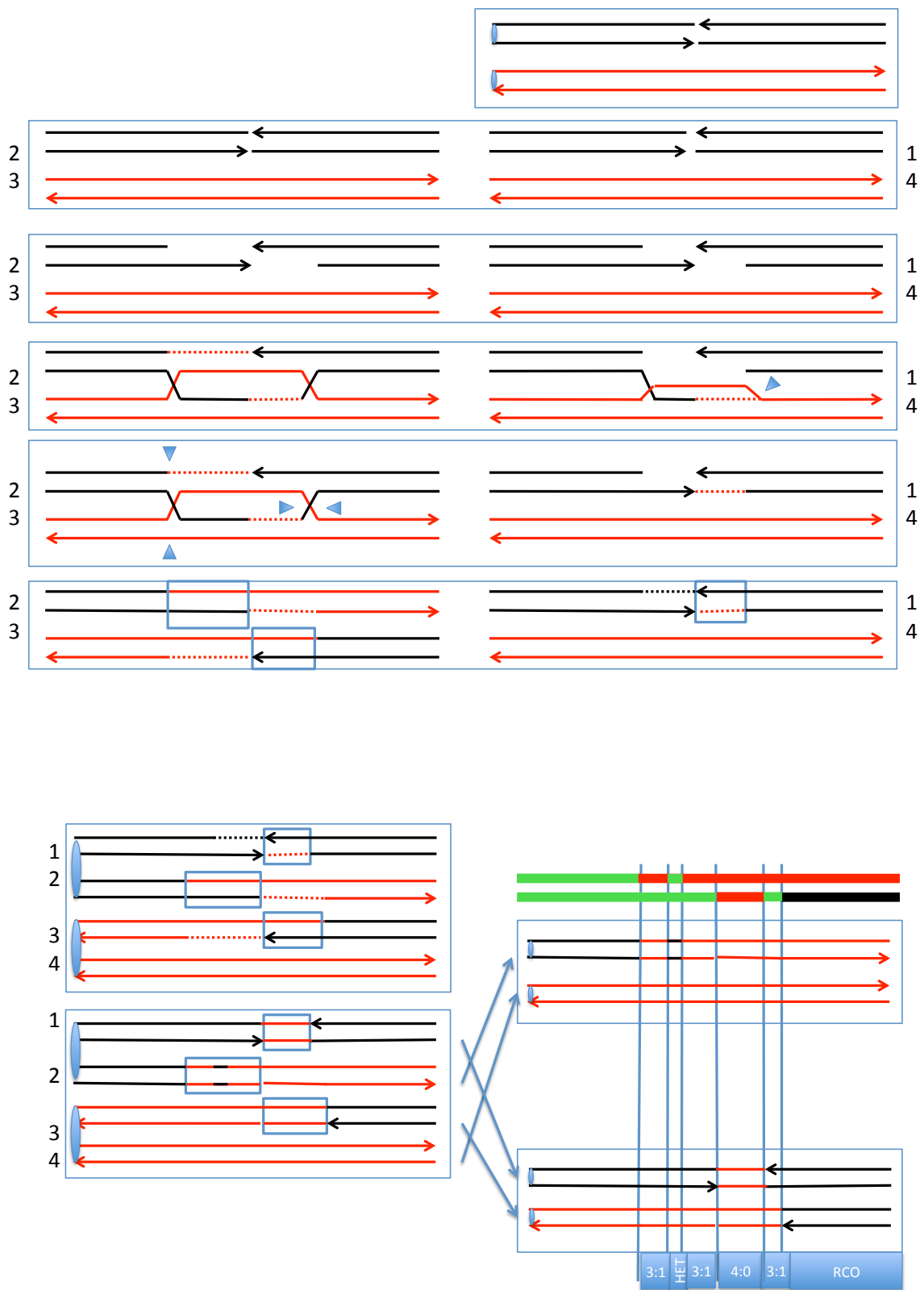

Figure S25. Description of the Class J4 event. In this event, the crossover is associated with a complex conversion tract. This event can be explained as a consequence of the repair of two DSBs, one by the DSBR pathway and one by the SDSA pathway. In addition, one of the heteroduplexes has “patchy” repair of mismatches.

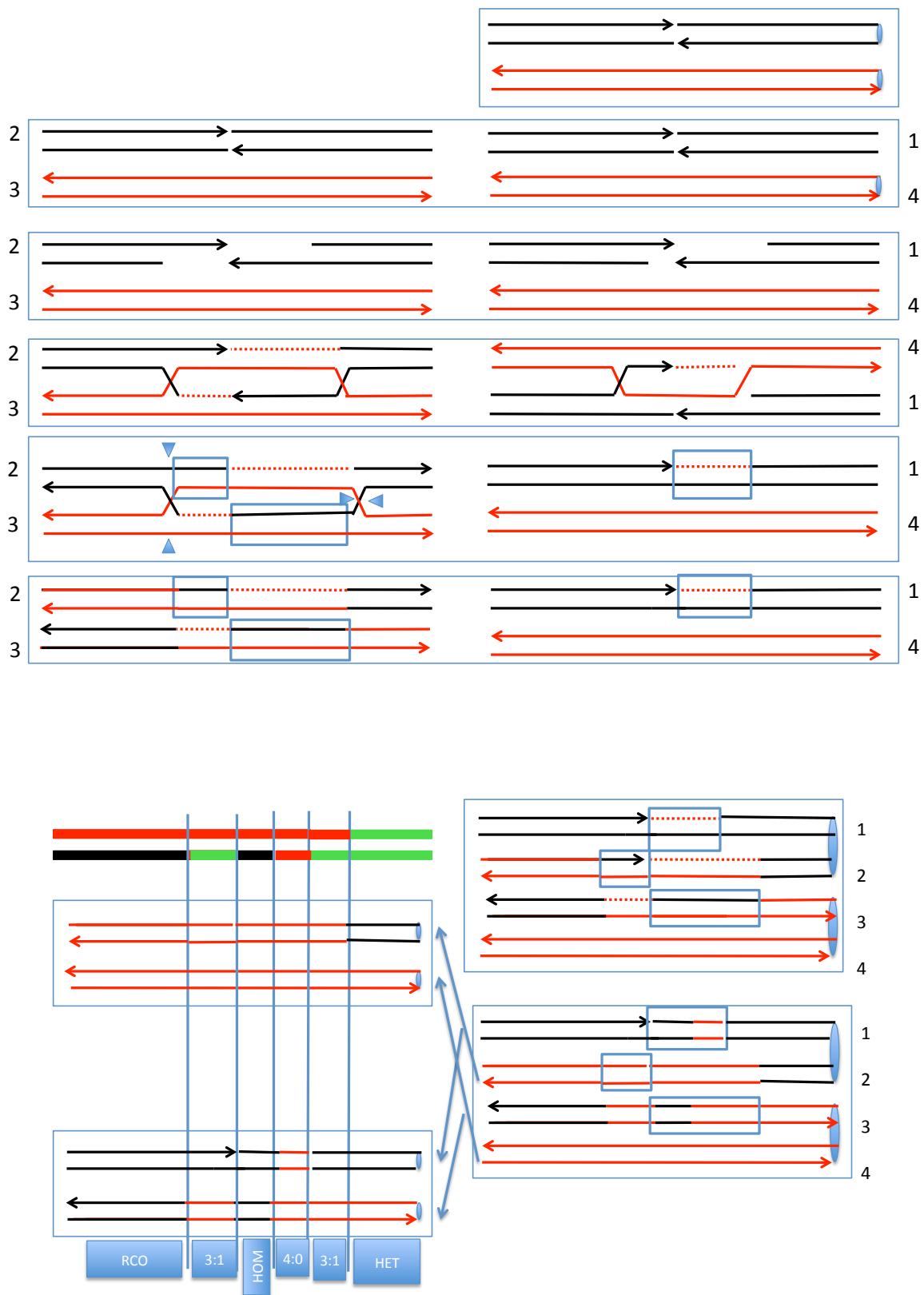

Figure S26. Description of the Class J5 event. In this event, the crossover is associated with a complex conversion tract. This event can be explained as a consequence of the repair of two DSBs, one by the DSBR pathway and one by the SDSA pathway. In addition, two of the heteroduplexes have "patchy" repair of mismatches.

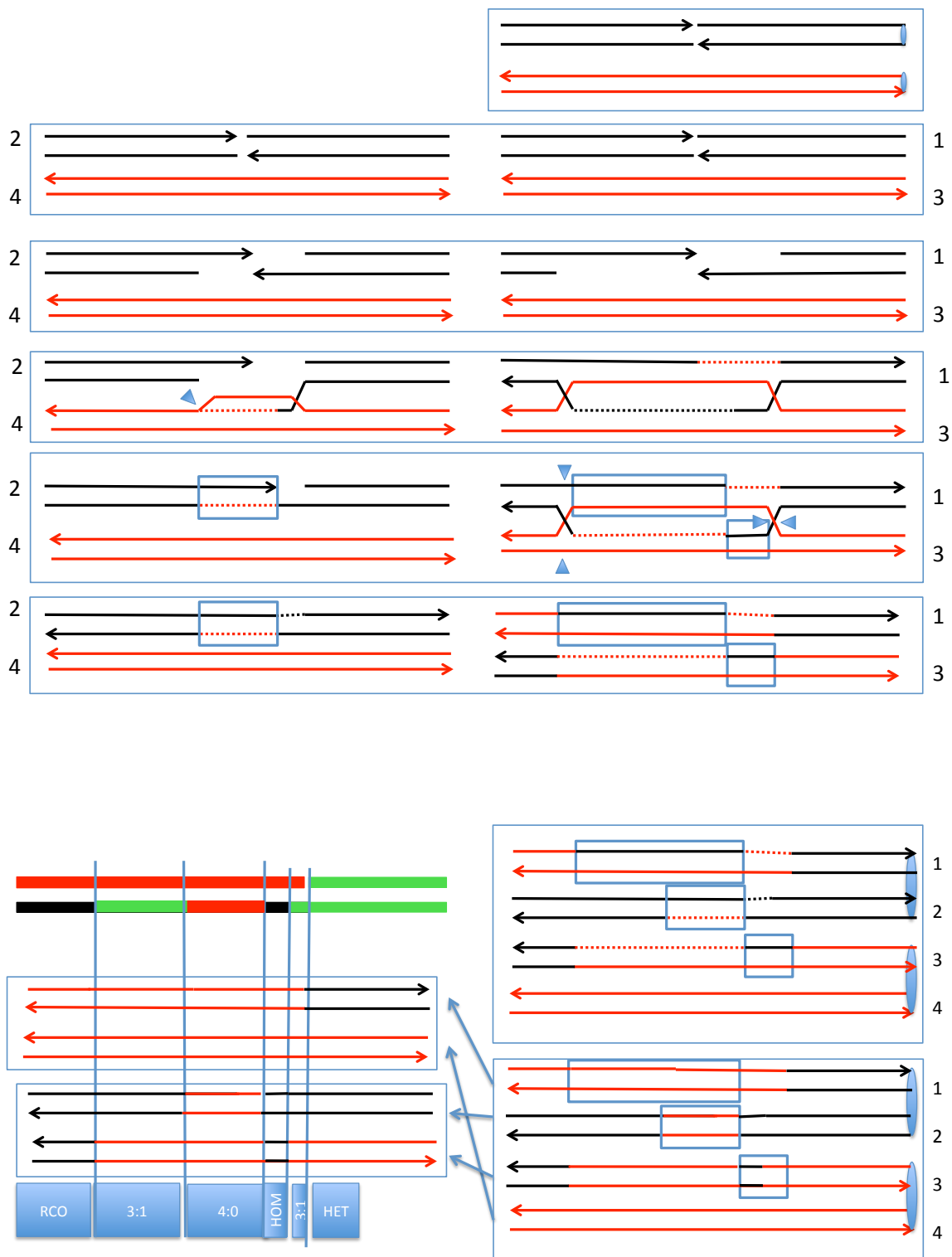

Figure S27. Description of the Class J6 event. In this event, the crossover is associated with a complex conversion tract. This event can be explained as a consequence of the repair of two DSBs, one by the DSBR pathway and one by the SDSA pathway. In addition, one of the heteroduplexes has “patchy” repair of mismatches.

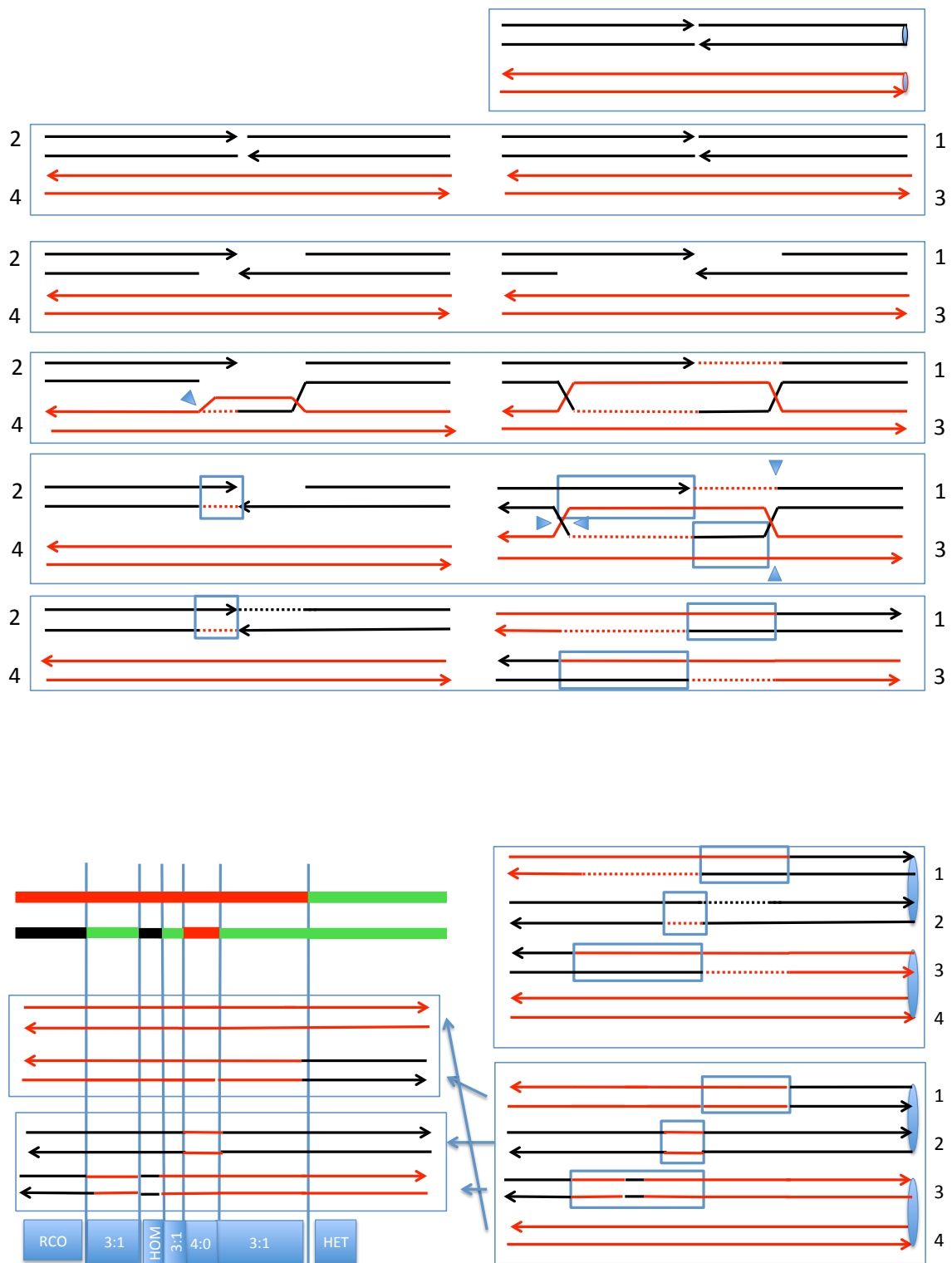

Figure S28. Description of the Class J7 event. In this event, the crossover is associated with a complex conversion tract. This event can be explained as a consequence of the repair of two DSBs, one by the DSBR pathway and one by the SDSA pathway. In addition, one of the heteroduplexes has “patchy” repair of mismatches.

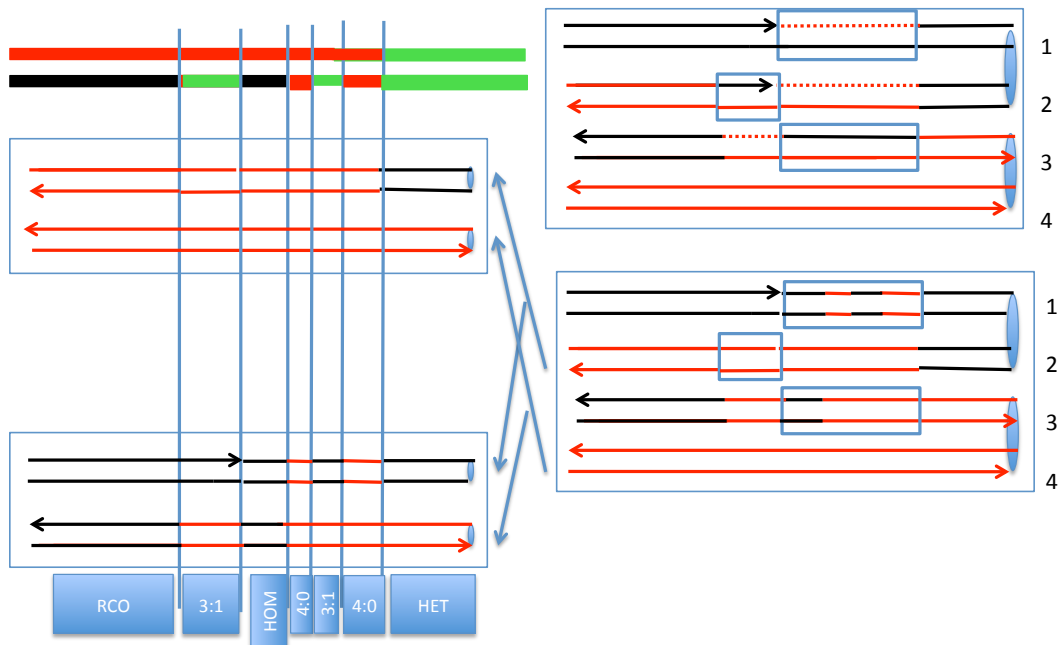
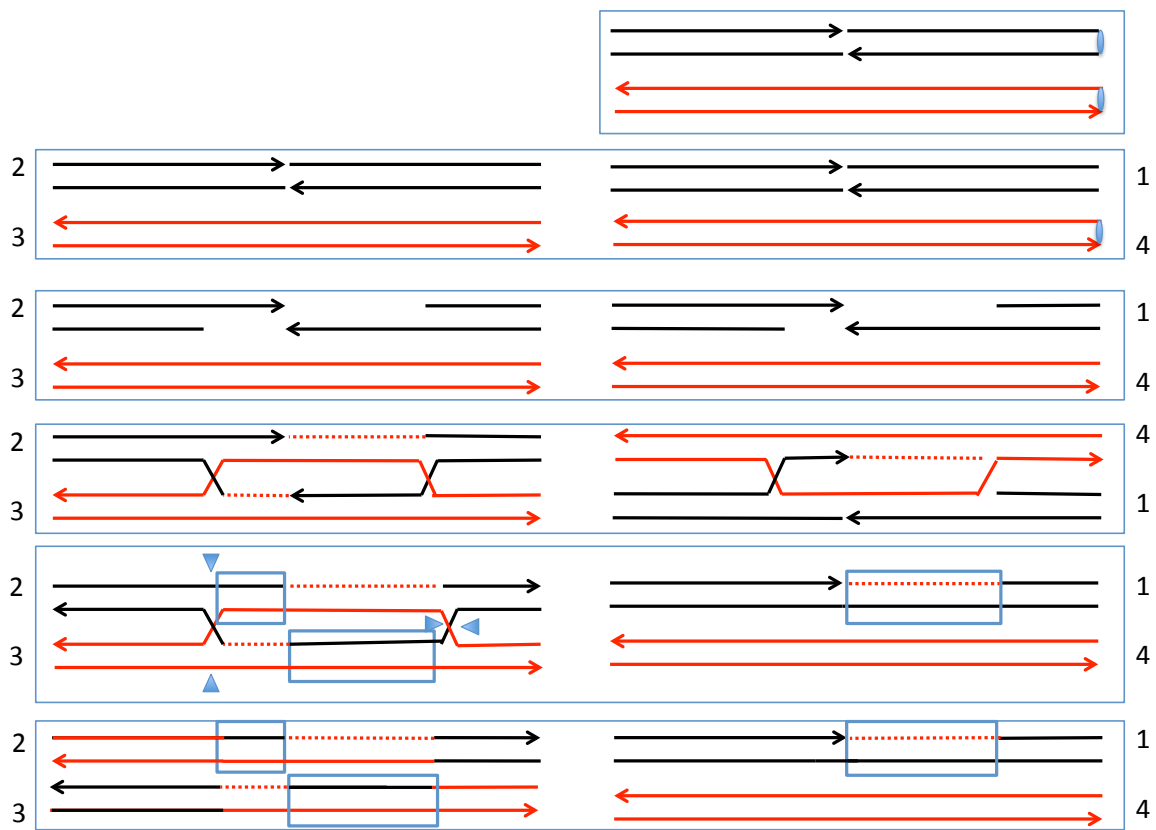

Figure S29. Description of the Class J8 event. In this event, the crossover is associated with a complex conversion tract. This event can be explained as a consequence of the repair of two DSBs, one by the DSBR pathway and one by the SDSA pathway. In addition, two of the heteroduplexes have “patchy” repair of mismatches.

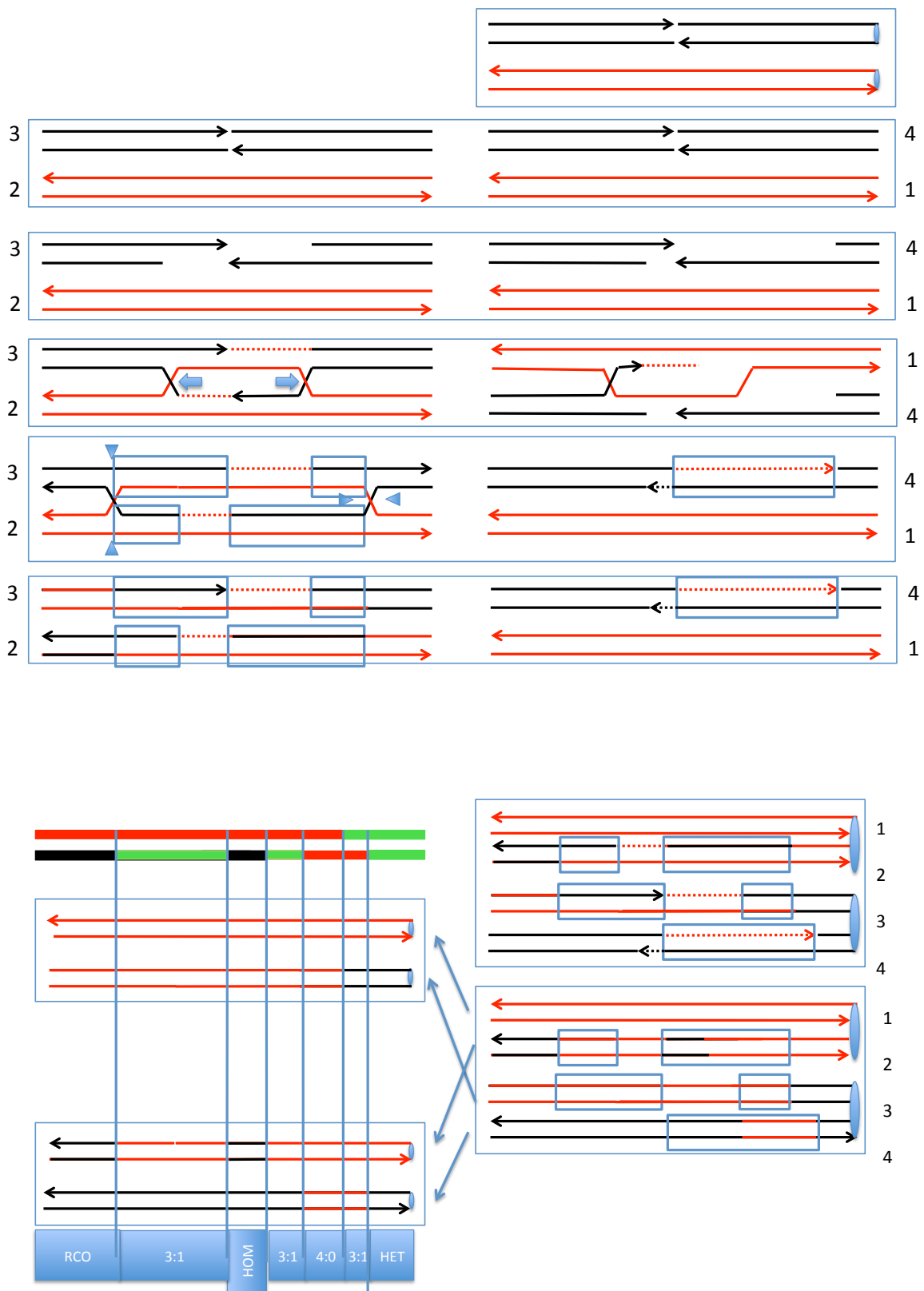

Figure S30. Description of the Class J9 event. In this event, the crossover is associated with a complex conversion tract. This event can be explained as a consequence of the repair of two DSBs, one by the DSBR pathway and one by the SDSA pathway. In addition, we postulate branch migration of the dHJ intermediate, and that two of the heteroduplexes have “patchy” repair of mismatches.

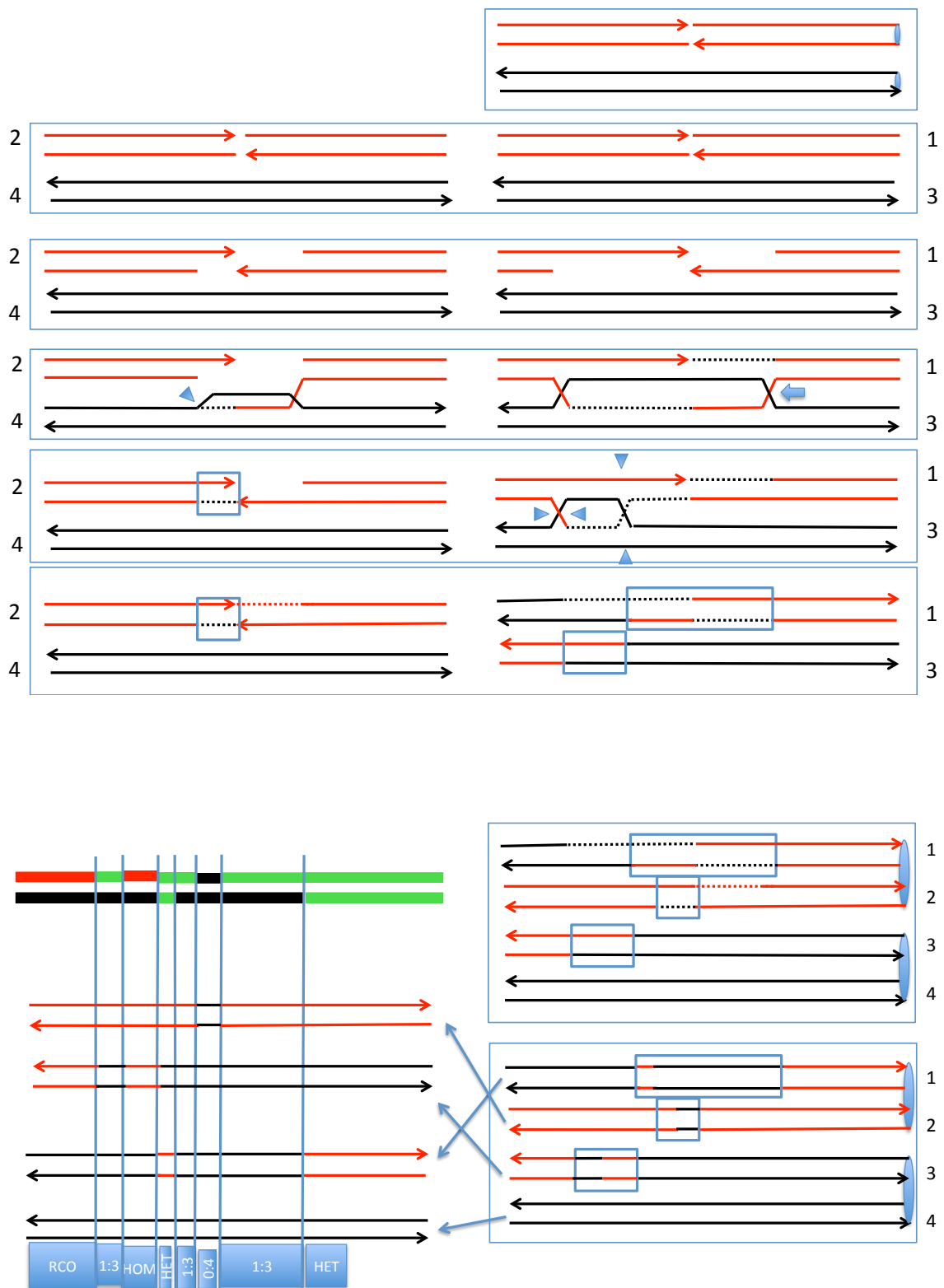

Figure S31. Description of the Class J10 event. In this event, the crossover is associated with a complex conversion tract. This event can be explained as a consequence of the repair of two DSBs, one by the DSBR pathway and one by the SDSA pathway. In addition, we postulate branch migration of the dHJ intermediate, and that three of the heteroduplexes have “patchy” repair of mismatches.

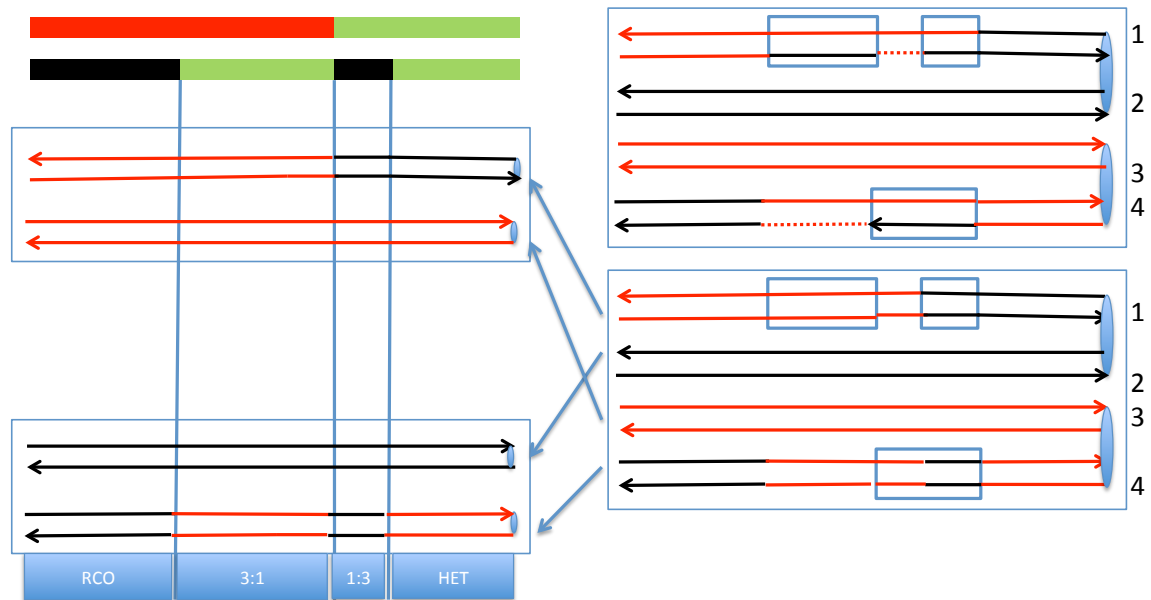
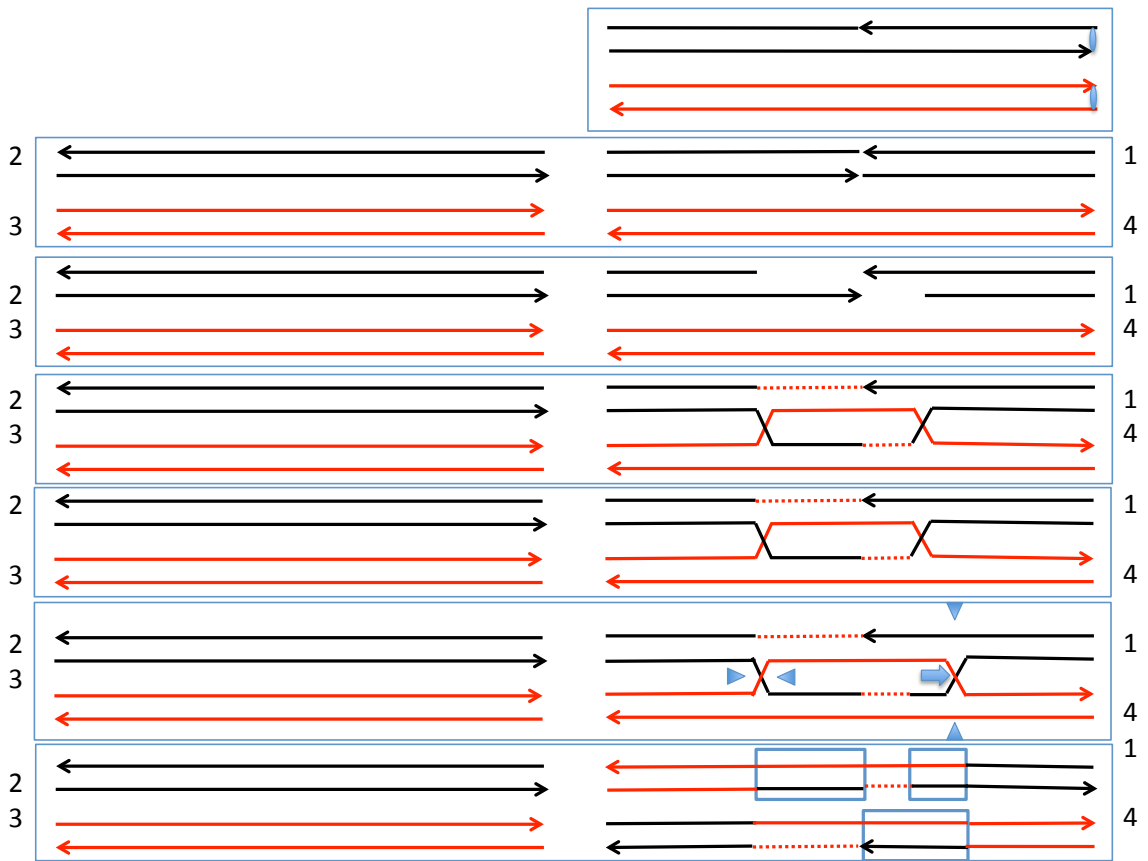

Figure S32. Description of the Class J11 event. In this event, the crossover is associated with a complex conversion tract. This event can be explained as a consequence of the repair of one DSB by the DSBR pathway, followed by branch migration of the resulting dHJ. In addition, one of the heteroduplexes has “patchy” repair of mismatches.

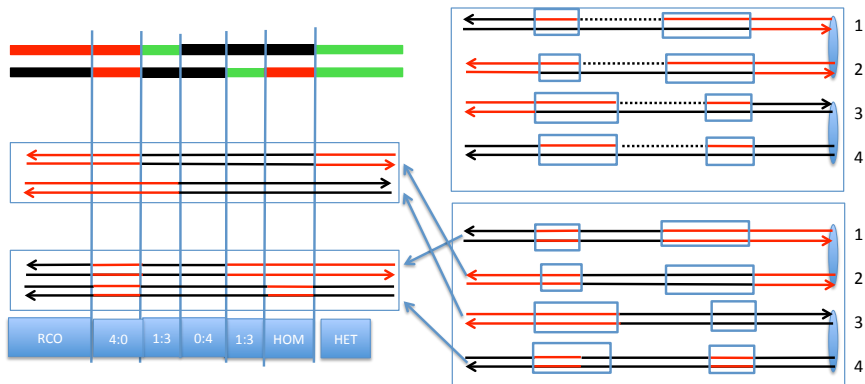
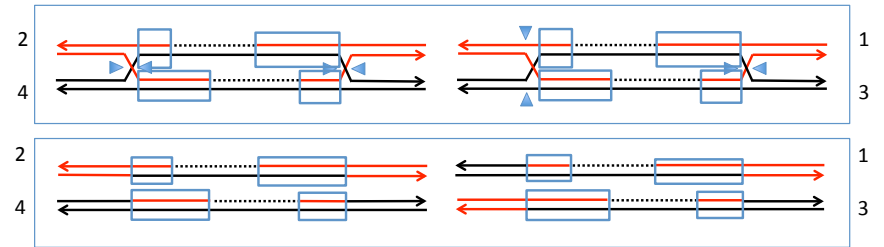
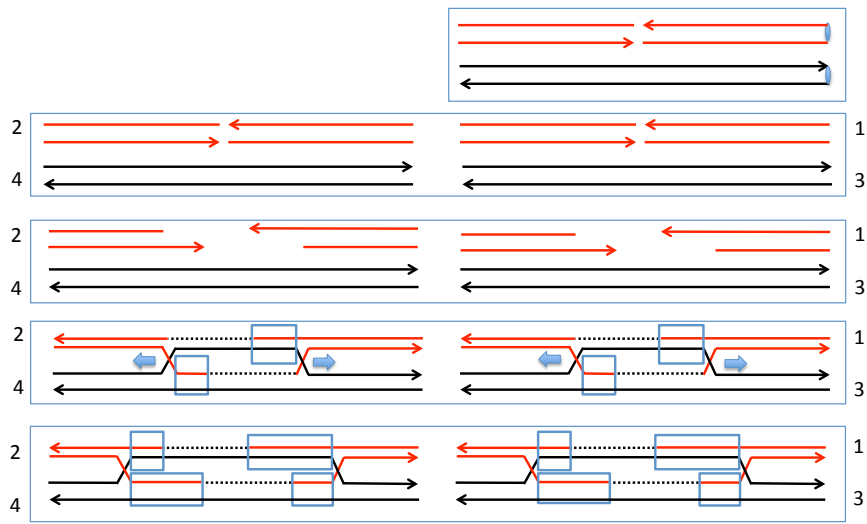

Figure S33. Description of the Class J12 event. In this event, the crossover is associated with a complex conversion tract. This event can be explained as a consequence of the repair of two DSBs by the DSBR pathway, followed by branch migration of the two resulting dHJs. In addition, one of the heteroduplexes has “patchy” repair of mismatches.

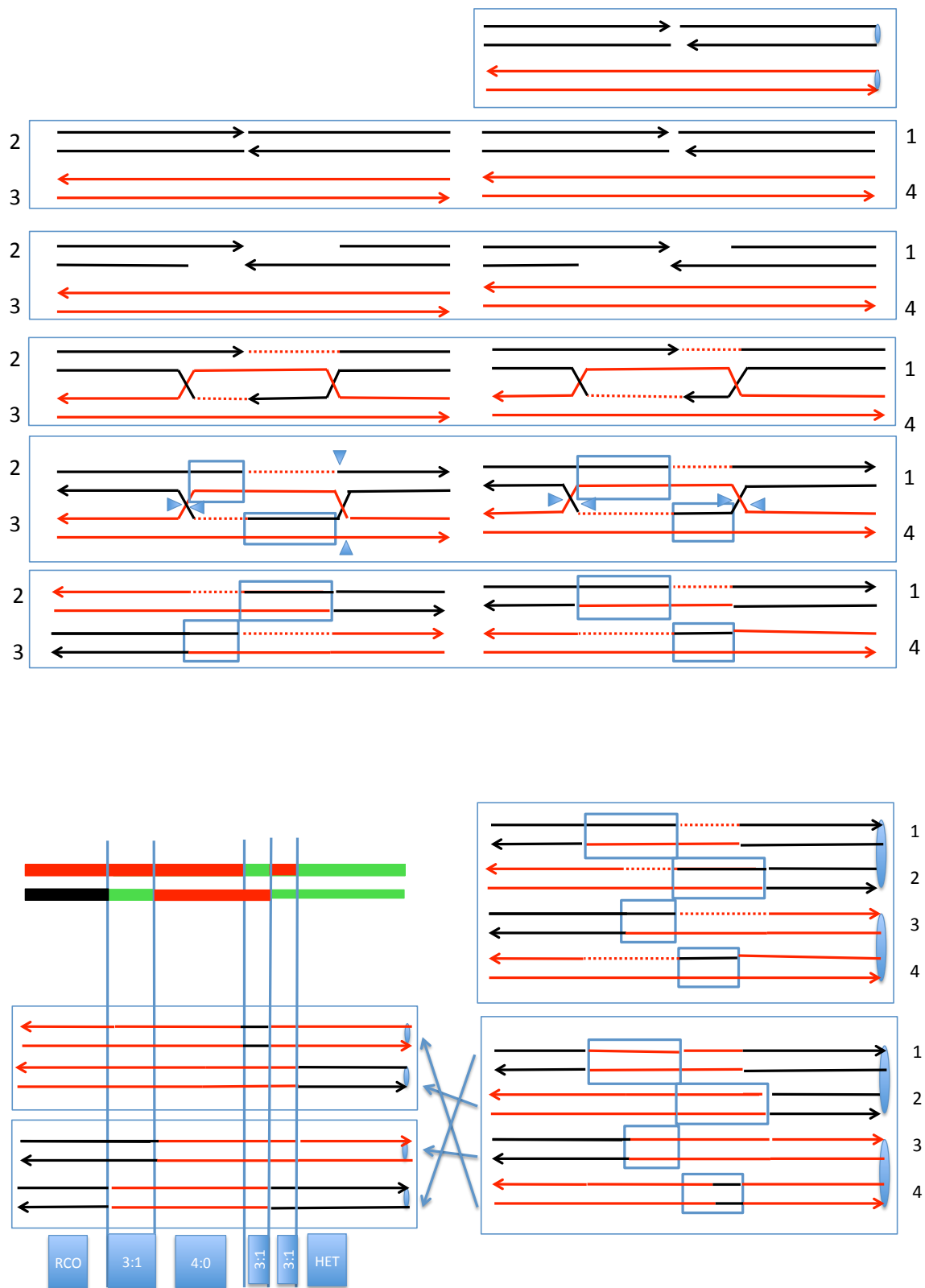

Figure S34. Description of the Class J13 event. In this event, the crossover is associated with a complex conversion tract. This event can be explained as a consequence of the repair of two DSBs by the DSBR pathway. In addition, one of the heteroduplexes has “patchy” repair of mismatches.

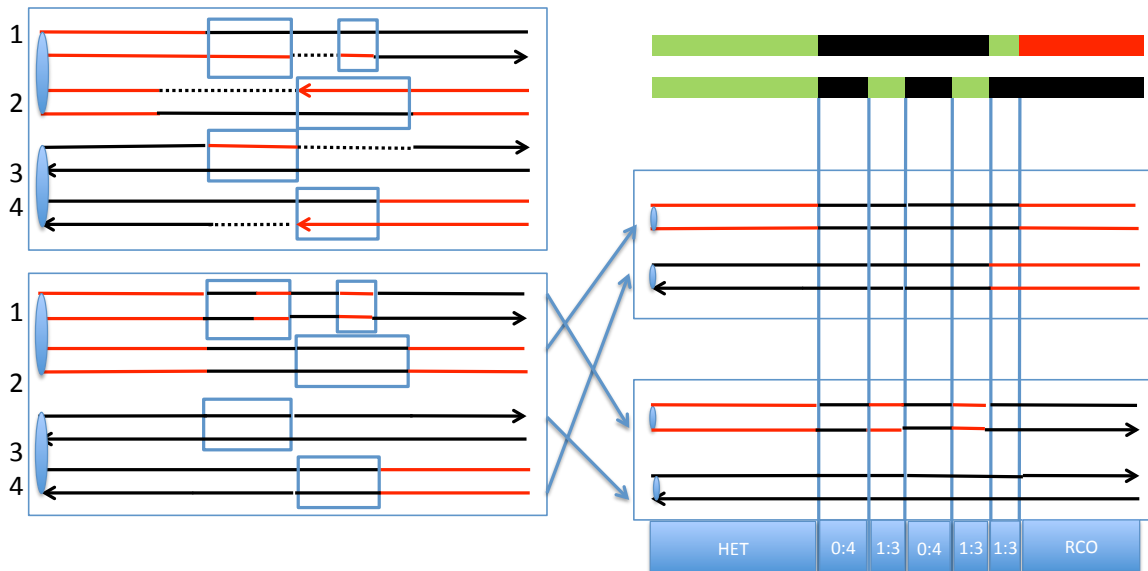
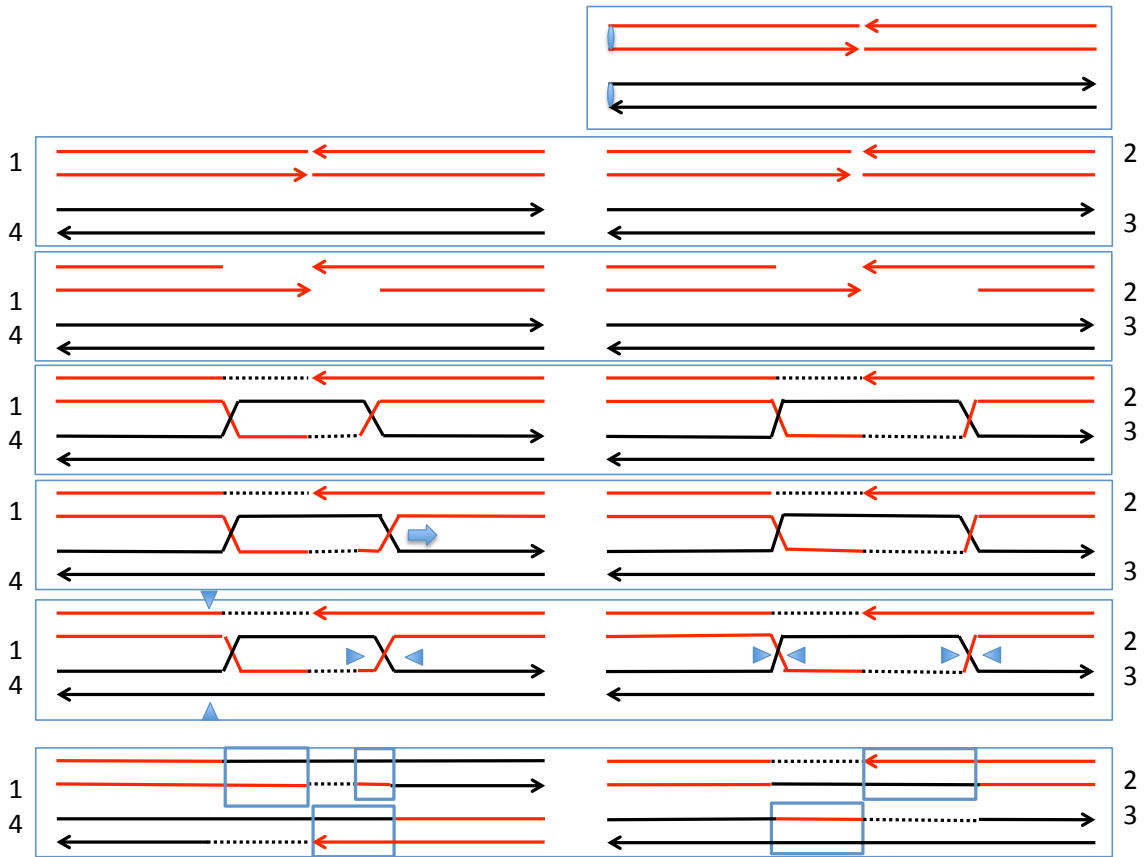

Figure S35. Description of the Class J14 event. In this event, the crossover is associated with a complex conversion tract. This event can be explained as a consequence of the repair of two DSBs by the DSBR pathway; one of the resulting dHJs undergoes branch migration. In addition, one of the heteroduplexes has “patchy” repair of mismatches.

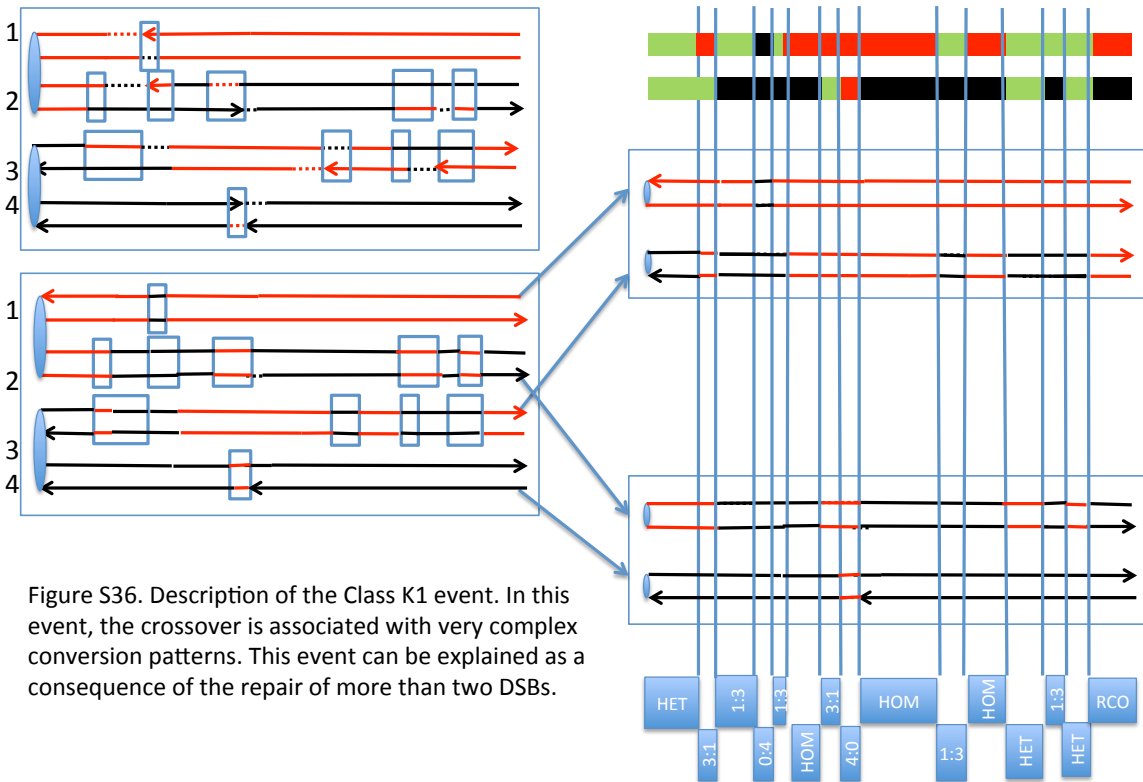
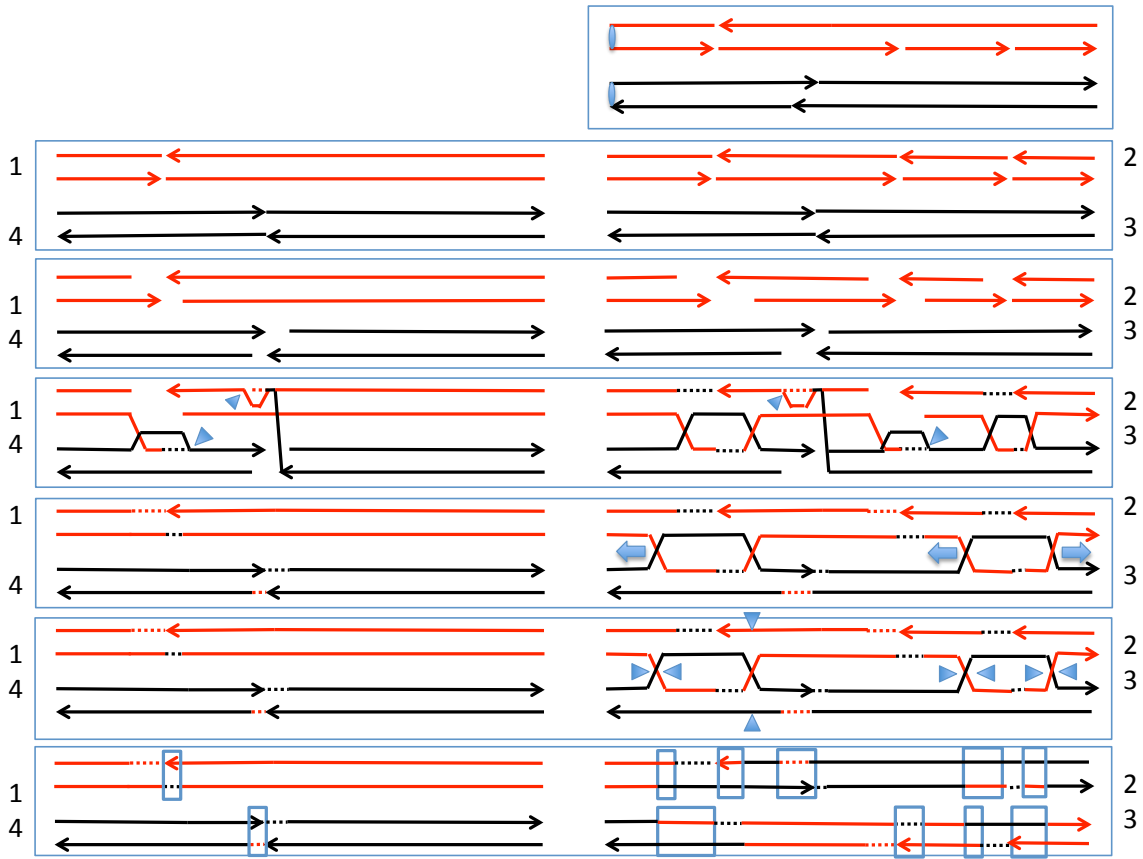

Figure S36. Description of the Class K1 event. In this event, the crossover is associated with very complex conversion patterns. This event can be explained as a consequence of the repair of more than two DSBs.

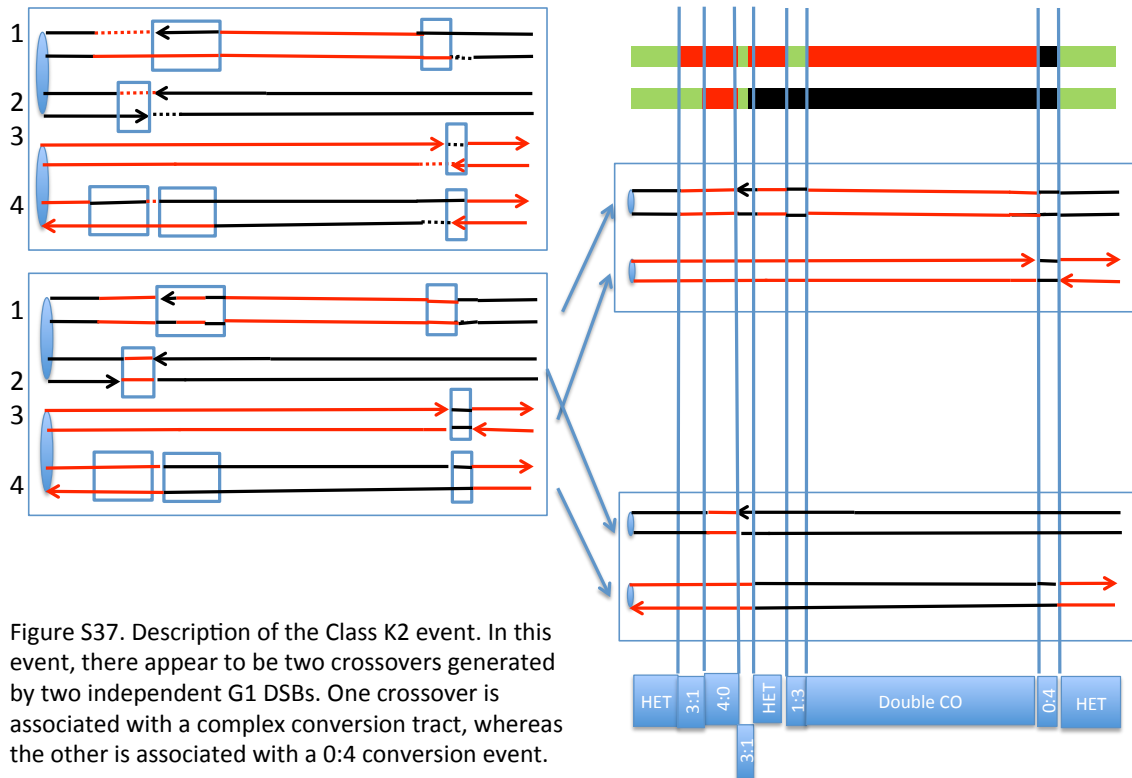
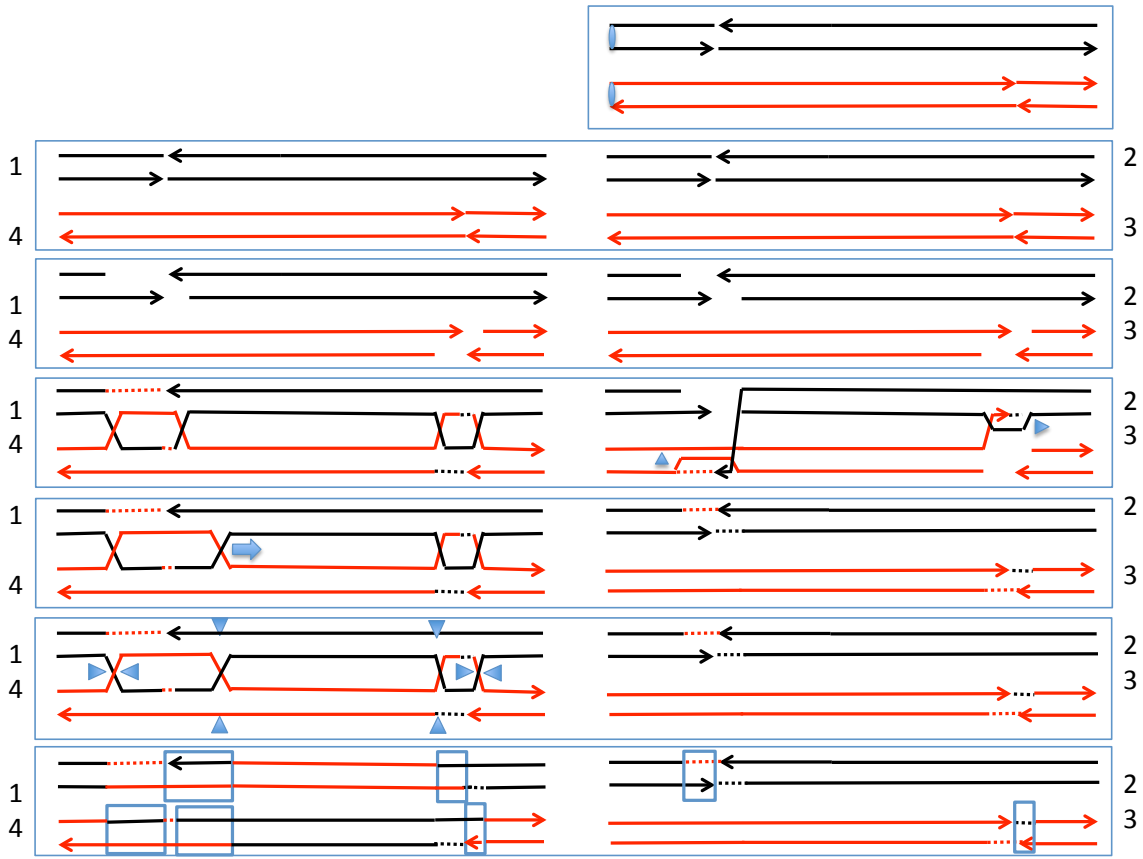

Figure S37. Description of the Class K2 event. In this event, there appear to be two crossovers generated by two independent G1 DSBs. One crossover is associated with a complex conversion tract, whereas the other is associated with a 0:4 conversion event.

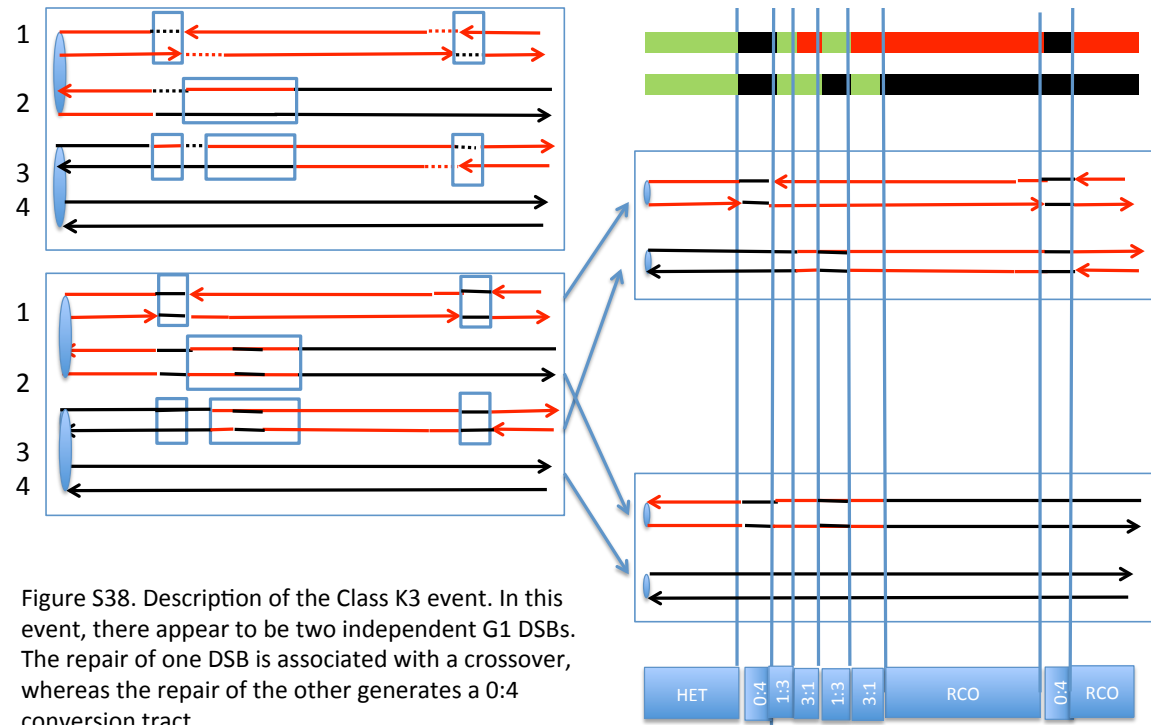
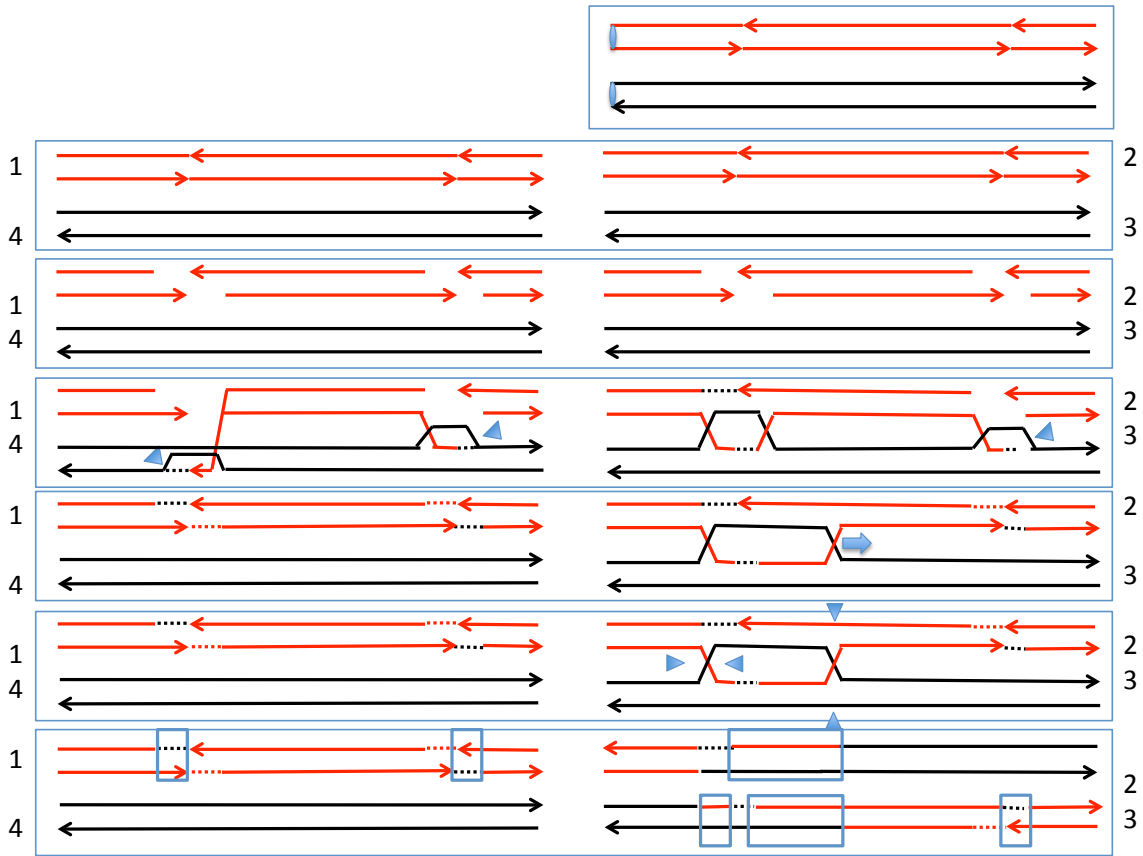

Figure S38. Description of the Class K3 event. In this event, there appear to be two independent G1 DSBs. The repair of one DSB is associated with a crossover, whereas the repair of the other generates a 0:4 conversion tract.

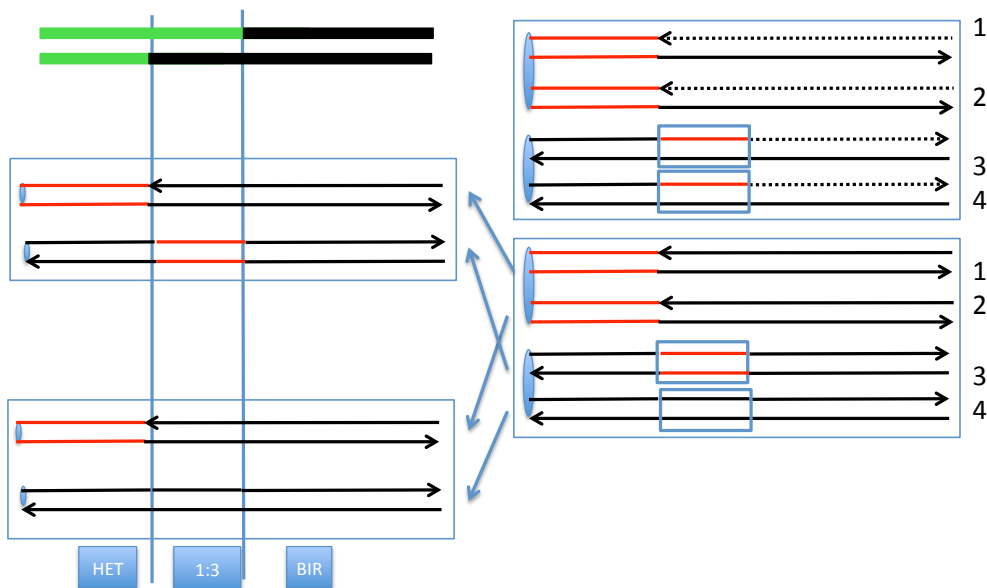
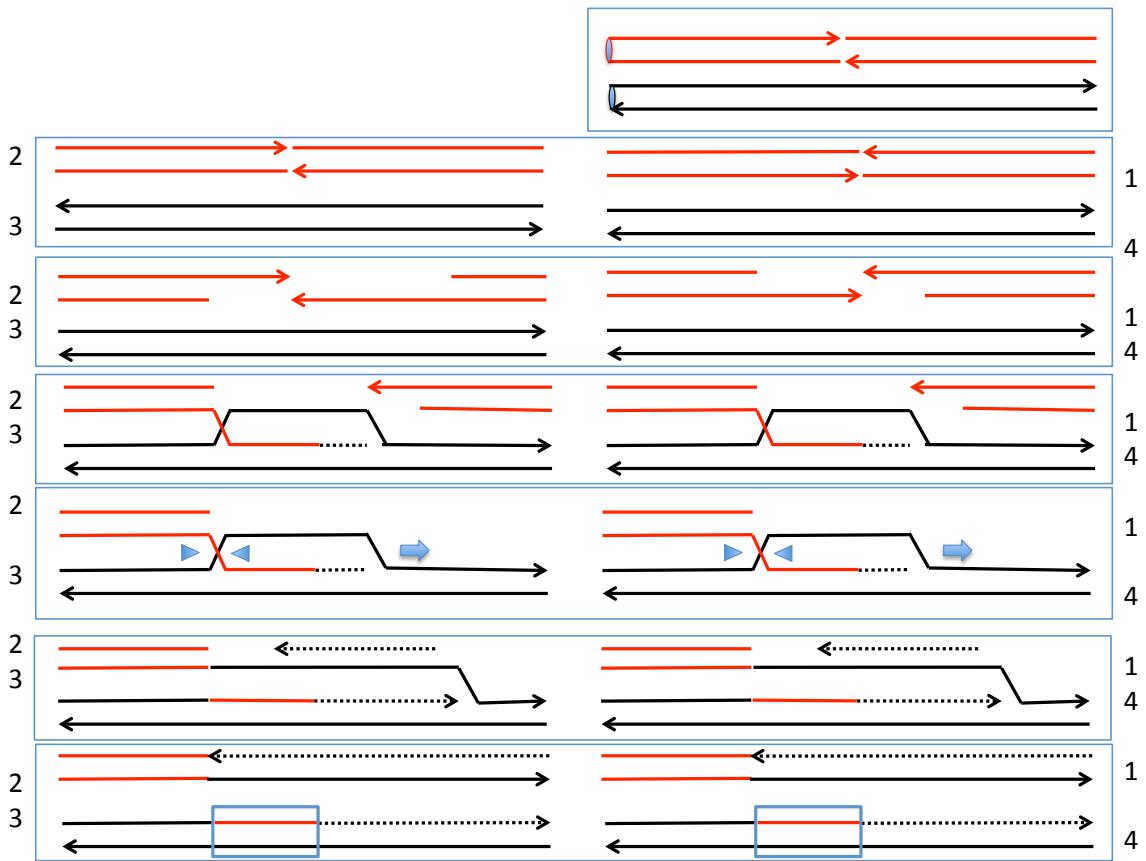

Figure S39. Description of the Class L1 event. In this event, there is a double BIR event associated with a 1:3 conversion. This event can be explained by the repair of two DSBs by BIR. Associated with the repair of each DSB is a region of heteroduplex.

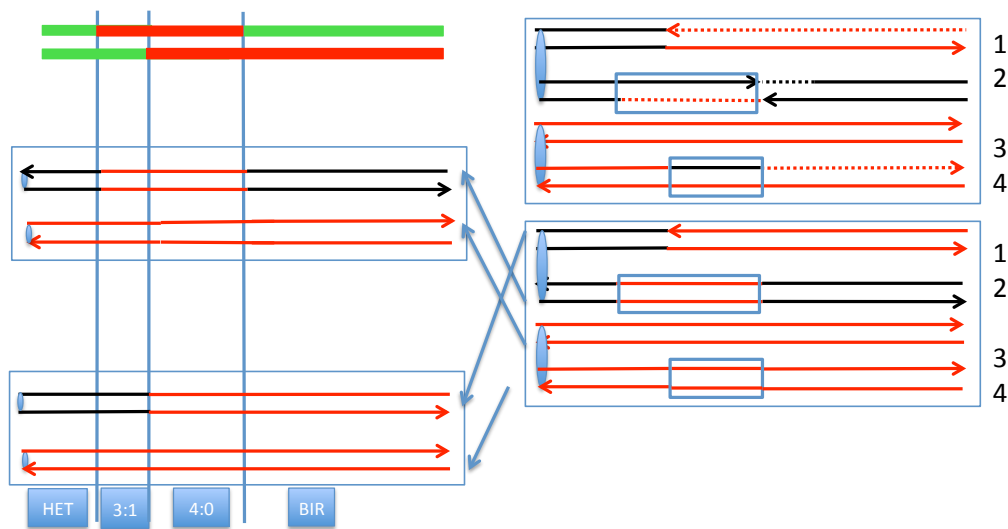
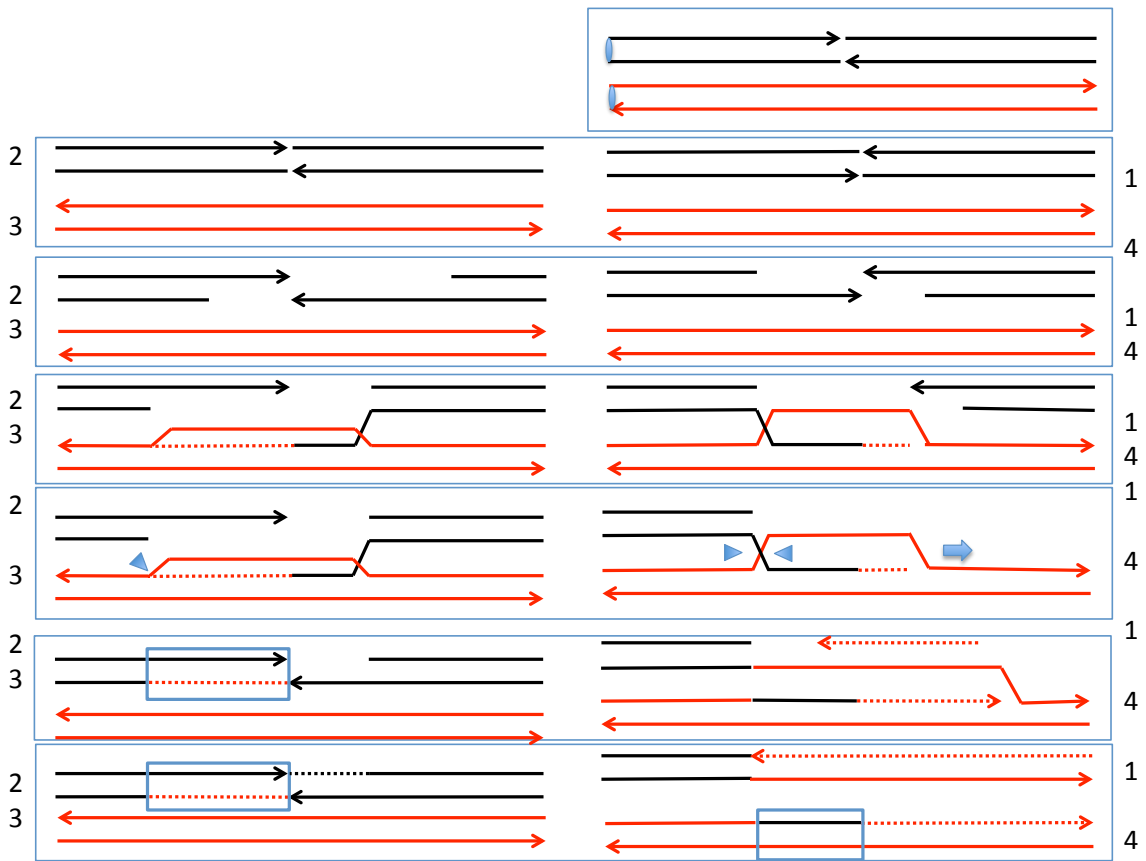

Figure S40. Description of the L2 (L3) events. In these events, there are hybrid conversion tracts associated with a BIR event. This event can be explained as a consequence of the repair of two DSBs, one by the SDSA pathway and the second by BIR. There are heteroduplexes associated with both repair events, and these heteroduplexes have different lengths.