

(A) Role of Succinate Transport in *iAF* Dominant Ethanol Production.
Deletions: *ycgT*, dihydroxyacetone phosphotransferase
pykA, pyruvate kinase

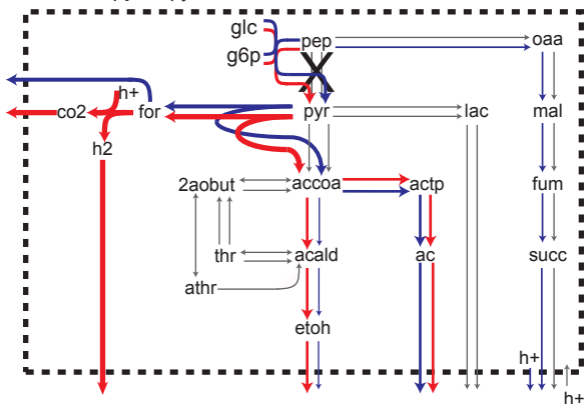

(B) Role of Hydrogen Transport in *iJR* Dominant Ethanol Production.
Deletions: *atpB*, ATP synthase

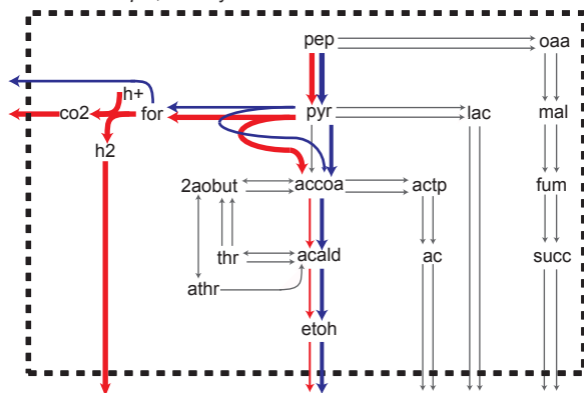

(C) Role of Hexokinase in *iJR* Dominant Ethanol Production.
Deletions: *edd*, 6-phosphogluconate dehydratase
pgi, glucose-6-phosphate isomerase

