

A. Fatty acid synthesis

Author: Kam Dahlquist and Chris Evelo et al.
 Maintained by: Chris Evelo for NuGO
 E-mail: mapps@bigcat.unimaas.nl
 Last modified: Inferred from human
 http://www.bigcat.unimaas.nl/mapps/
 Copyright © Gladstone Institutes and BIGCaT Bioinformatics

Fatty Acid Biosynthesis

Gene Database
 Mm-Std_20070817.gdb
 Expression Dataset
 Name: fpkm4genMapp
 Color Set: KO/WT <= 0.8
 Legend: KO/WT >= 1.2
 KO/WT <= 0.8
 No criteria met
 Not found

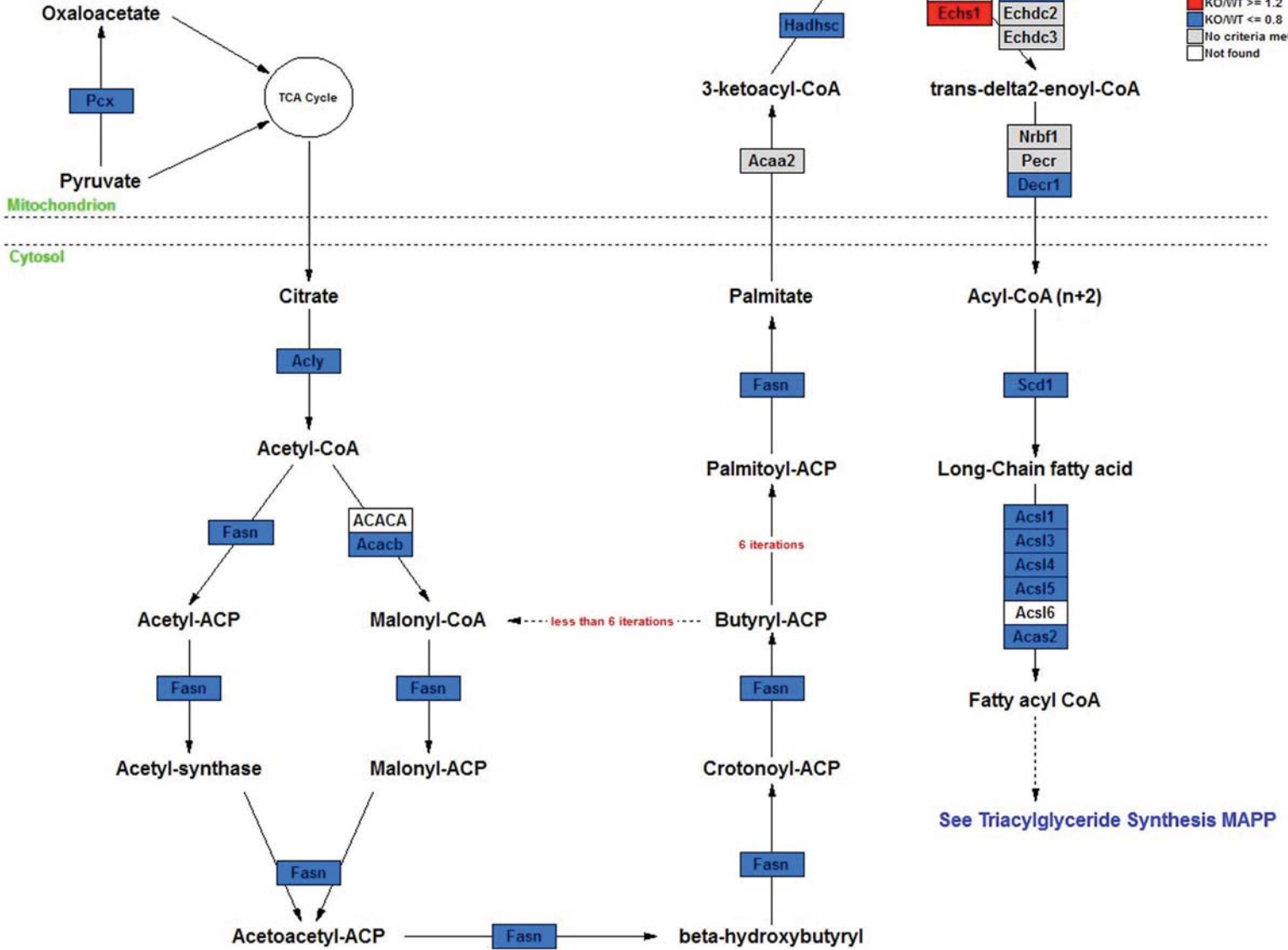

B. Triglyceride synthesis

Author: Chris Evelo et al.
 Maintained by: Chris Evelo for NuGO
 E-mail: mapps@bigcat.unimaas.nl
 Last modified: Inferred from human
 http://www.bigcat.unimaas.nl/mapps/
 Copyright © 2005, BiGCaT Bioinformatics

Triacylglyceride Synthesis

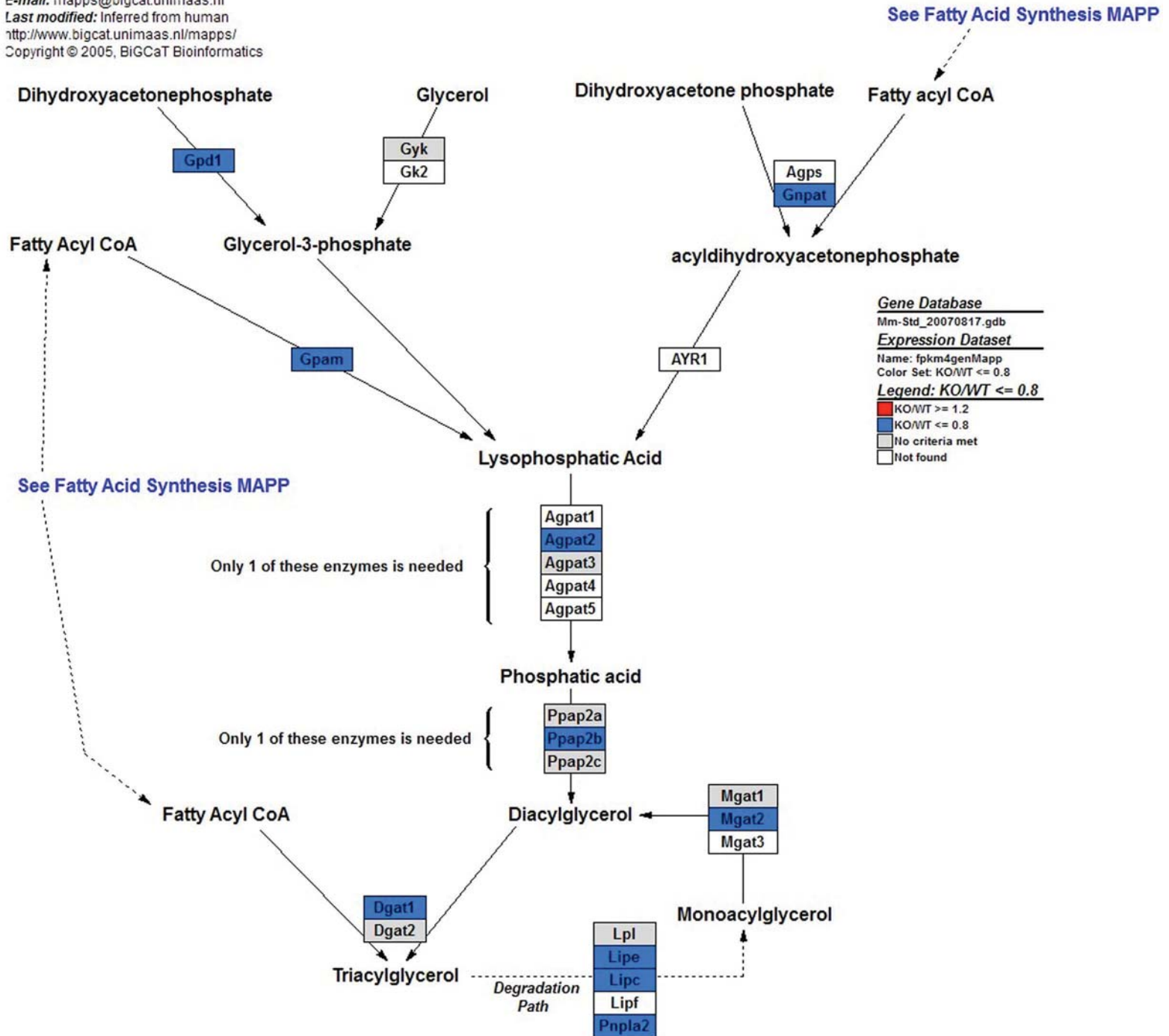

C. Cholesterol synthesis

Author: Michael Lieberman and Ned Mantei
E-mail: genmapp@gladstone.ucsf.edu
 Right click for notes
 Copyright © 2004, Gladstone Institutes

Cholesterol Biosynthesis

Fatty Acid Degradation

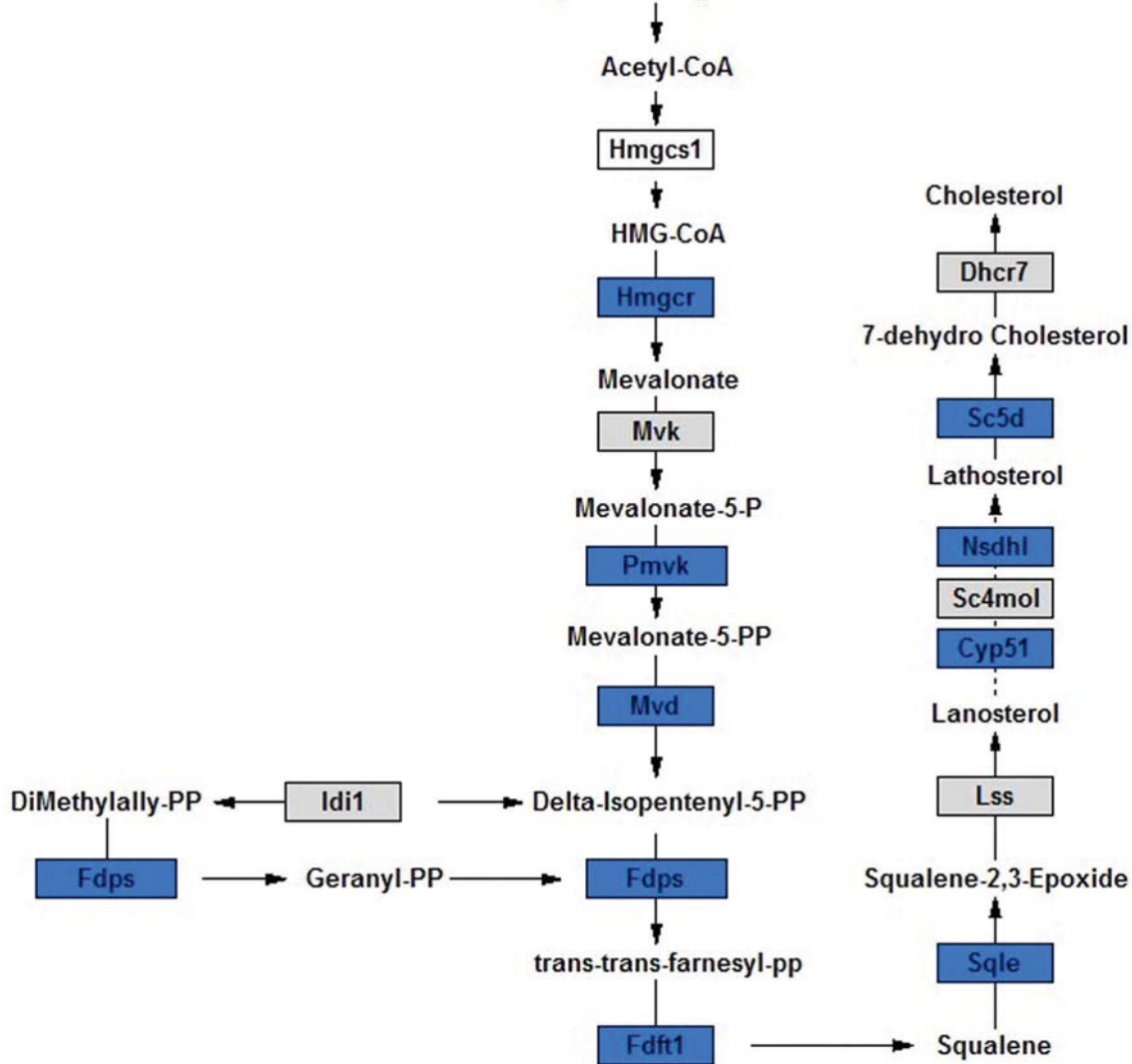

Gene Database

Mm-Std_20070817.gdb

Expression Dataset

Name: fpkm4genMapp

Color Set: KO/WT <= 0.8

Legend: KO/WT <= 0.8

- KO/WT >= 1.2
- KO/WT <= 0.8
- No criteria met
- Not found

D. Fatty acid beta oxidation

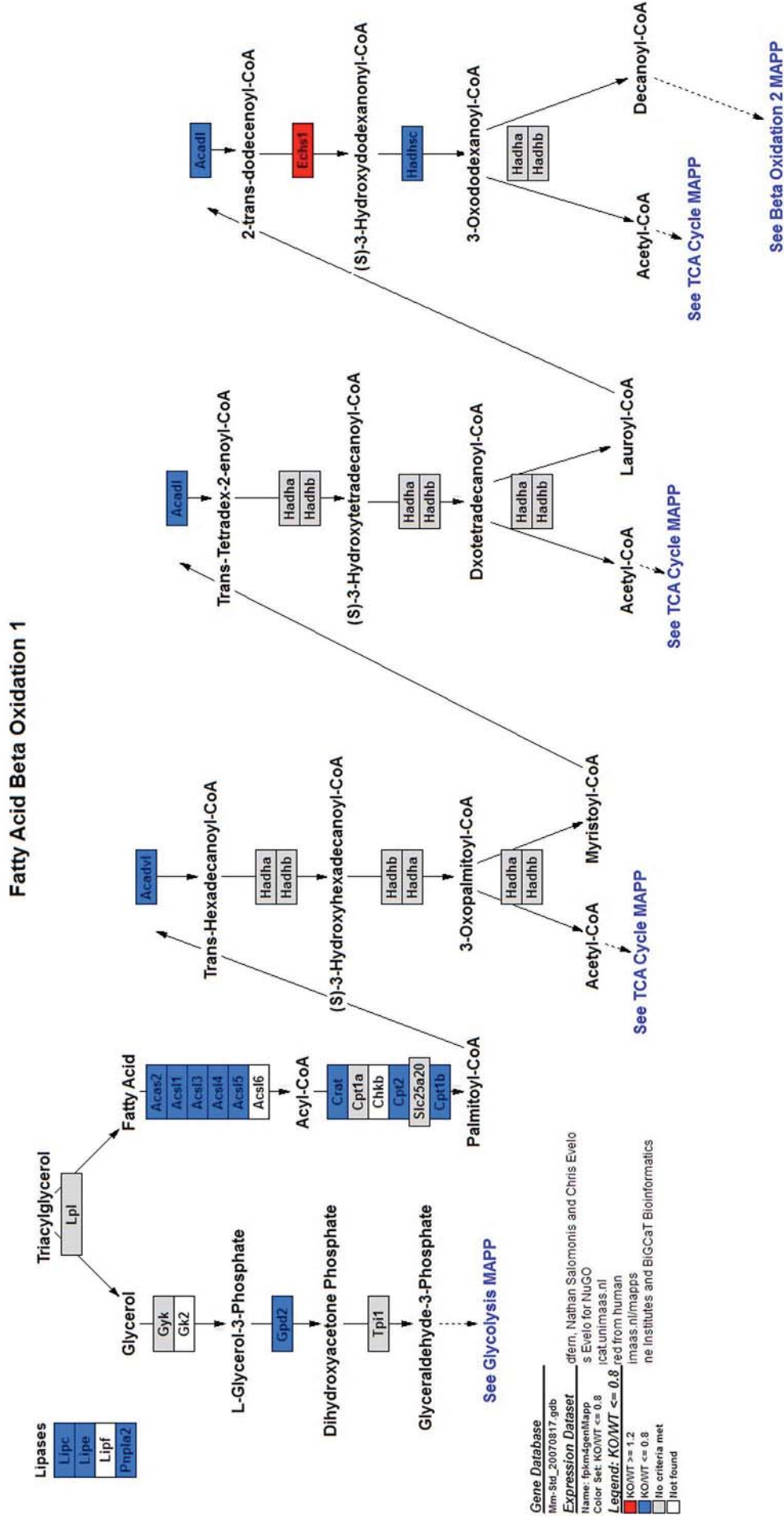

Fatty Acid Beta Oxidation 2

Author: Charles Radfern, Nathan Salomonis and Chris Evelo
 Maintained by: Chris Evelo for NUGO
 E-mail: mapps@bigcat.unimaas.nl
 Last modified: Inferred from human
 http://www.bigcat.unimaas.nl/mapps
 Copyright © 2005, BIGCAT Bioinformatics

Gene Database
 Mm-Std_20070817.gdb
 Expression Dataset
 Name: fpkm4gen/mapp
 Color Set: KO/WT <= 0.8
 Legend: KO/WT <= 0.8
 KO/WT >= 1.2
 No criteria met
 Not found

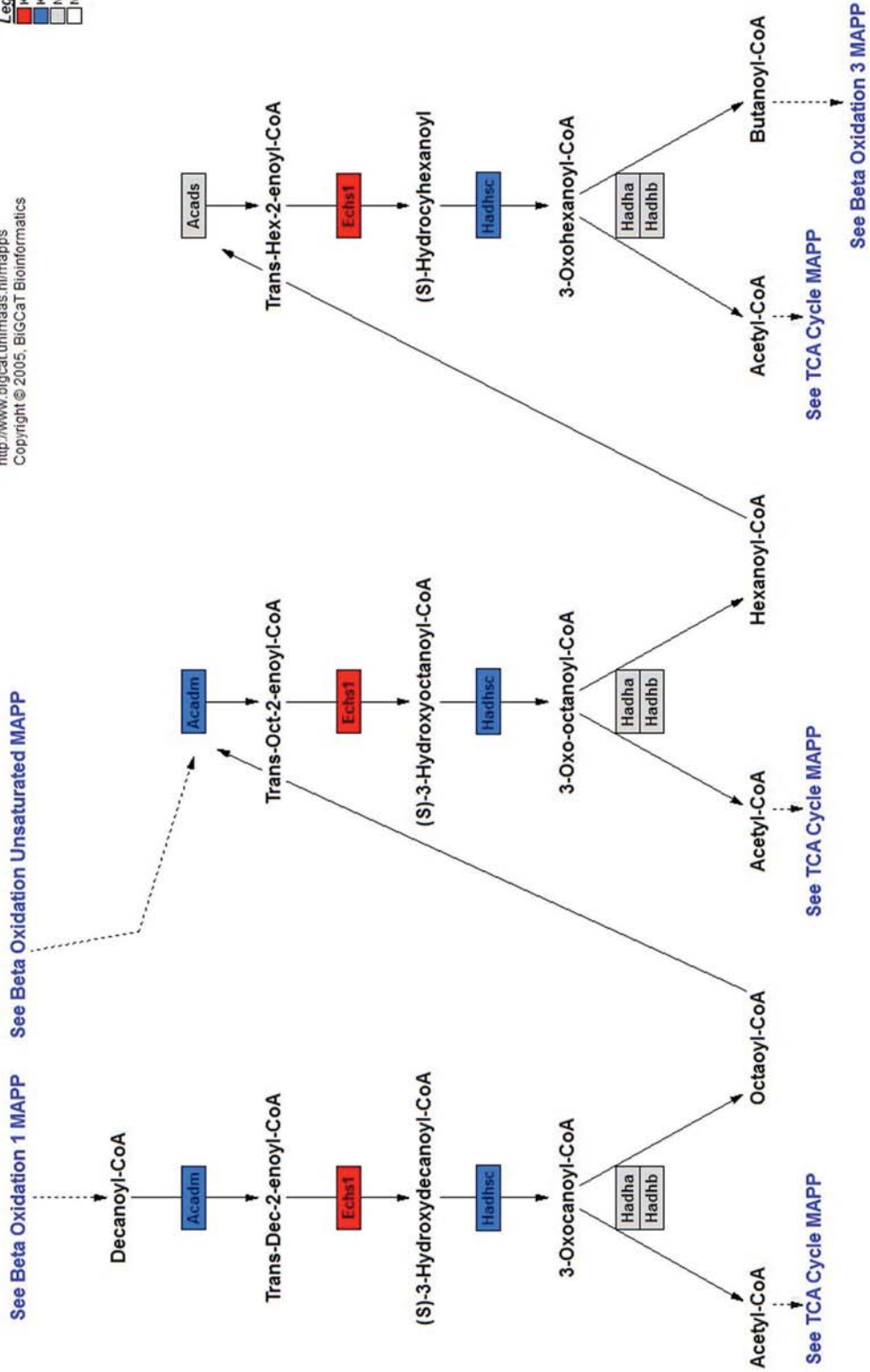

Fatty Acid Beta Oxidation 3

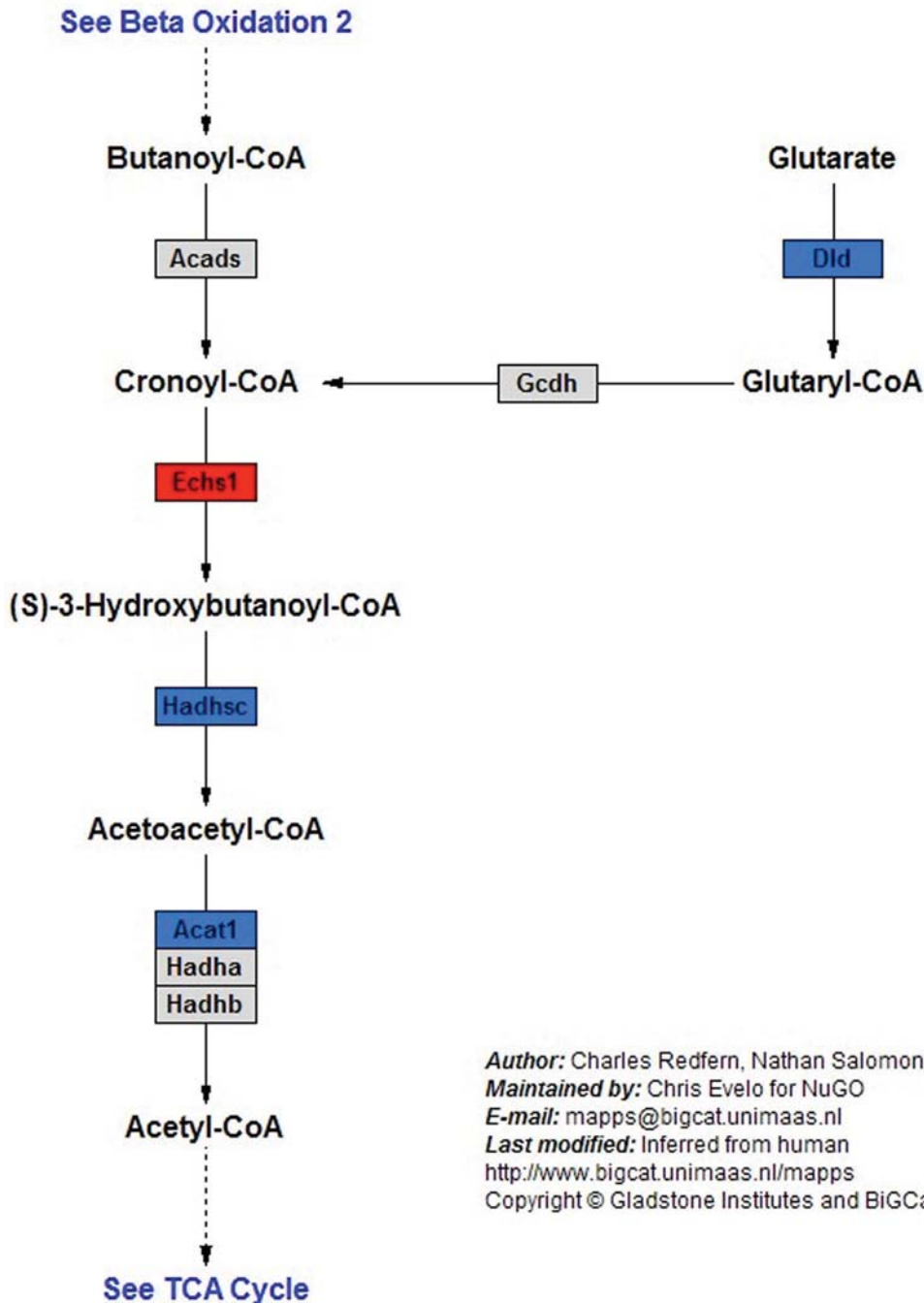

Gene Database

Mm-Std_20070817.gdb

Expression Dataset

Name: fpkm4genMapp

Color Set: KO/WT <= 0.8

Legend: KO/WT <= 0.

Red: KO/WT >= 1.2

Blue: KO/WT <= 0.8

Grey: No criteria met

White: Not found

Author: Charles Redfern, Nathan Salomonis and Chris Evelo

Maintained by: Chris Evelo for NuGO

E-mail: mapps@bigcat.unimaas.nl

Last modified: Inferred from human

<http://www.bigcat.unimaas.nl/mapps>

Copyright © Gladstone Institutes and BiGCaT Bioinformatics