

## Analysis of Integrated Avian RNA Tumor Virus DNA in Transformed Chicken, Duck, and Quail Fibroblasts

JAN L. SABRAN,<sup>1</sup> TERESA W. HSU,<sup>2</sup> CAROL YEATER,<sup>2</sup> AKIRA KAJI,<sup>1</sup> WILLIAM S. MASON,<sup>2</sup> AND JOHN M. TAYLOR<sup>2\*</sup>

*Department of Microbiology, University of Pennsylvania, Philadelphia, Pennsylvania 19174,<sup>1</sup> and The Institute for Cancer Research, Fox Chase Cancer Center, Philadelphia, Pennsylvania 19111<sup>2</sup>*

Received for publication 21 July 1978

The state of integration of avian sarcoma virus DNA in the genomes of transformed chicken, duck, and quail fibroblasts was deduced by means of restriction enzyme digestion of total cell DNA, gel electrophoresis, and subsequent analysis by the procedure of Southern. The cells used in these studies were either mass-infected cultures or clones of infected cells selected by their ability to form colonies in agar. For both mass-infected cultures and clones of cells of all three species, we found that integration occurred at a specific site on the viral genome but appeared to occur at many sites on the cell genome. At least some of the integrated viral DNA existed as intact nonpermuted species flanked by direct terminal repeats of at least 0.134 megadalton (217 base pairs). For each of 12 transformed quail clones studied, it was possible to detect, after digestion with *Kpn* I, unique junctions between viral and cellular DNA. That is, at our level of analysis, the integration site on the cell genome for each clone was different. However, within each of the 17 chicken and 9 duck clones of transformed cells, a heterogeneity presumably occurred during the outgrowth of the cell clone population, in that we could not readily detect identifiable cell-virus junction fragments.

The *in vivo* replication of the RNA tumor virus genome involves transcription of viral RNA into a double-stranded DNA intermediate, integration of such an intermediate into the host DNA, and the subsequent transcription of viral RNA from the integrated viral DNA by cellular RNA polymerase II as reviewed in reference 22. Guntaka et al. (8) have studied the avian sarcoma virus (ASV) DNA intermediates and have shown them to be of two conformations: linear and circular. Recently, we showed (10) that the linear intermediates are longer than expected for a "unit length" DNA transcript of the viral RNA, that is, for a uniform transcript of the viral RNA excluding the 3'-terminal polyadenylic acid [poly(A)], and one of the two copies of a small terminal repeat (STR) of 16 to 21 base pairs (bp) that probably facilitates the initial transcription of RNA into DNA (16). As summarized in Fig. 1, we have shown that the extra sequences on the linear DNA intermediates represent a larger terminal repeat (LTR) of at least 217 bp and maybe as much as 800 bp. The circular intermediates are of two discrete size classes. The smaller appears to be of unit length, and the larger has 340 bp of redundant sequences. At this time there is no definitive evidence as to whether the linear or the circular

DNA is the immediate precursor to integrated viral DNA.

In this manuscript we have shown that the integration of viral DNA into the DNA of either chicken, duck, or quail cells did not bring about a detectable level of permutation of viral DNA sequences and, of more importance, that at least some and possibly all of the large terminal redundancy was maintained.

(A preliminary account of these findings was presented at the ICN-UCLA Symposium on Persistent Viruses held in March 1978 at Keystone, Colo. [21].)

### MATERIALS AND METHODS

**Cells and viruses.** Embryonated eggs of *gs(-) chf(-)* White Leghorn chickens were obtained from Heisdorf and Nelson Laboratories, Redmond, Wash.; Japanese quail (*Coturnix coturnix*) eggs were obtained from Life Sciences, Inc., St. Petersburg, Fla., through the National Cancer Institute Office of Program Logistics and Resources, and from Truslow Farms, Inc., Chestertown, Md.; Pekin duck eggs were obtained from Truslow Farms. Fibroblast cultures were established from 10- to 12-day avian embryos as previously described (14). Cell cultures were grown at 37 to 38°C.

The viruses used in this study were focus-cloned stocks of the Prague strain of Rous sarcoma virus of subgroup A (PrA) and the Bratislava 77 (B77) strain

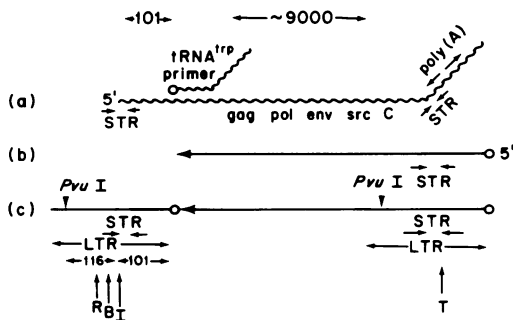

FIG. 1. Transcription of the ASV RNA genome into DNA. The diagrams are not according to scale. The numbers represent length in nucleotides. (a) shows the structure of the RNA as deduced from the work of several laboratories (as reviewed in reference 21). The relative positions of the four viral genes, *gag*, *pol*, *env*, and *src*, and the so-called constant, or *C* region, are indicated. The STR is 16 to 21 nucleotides. The open circle at the 3' terminus of the tRNA primer represents the origin of DNA synthesis. (b) is a hypothetical unit length transcript of the viral RNA into DNA excluding the 3'-terminal poly(A) and one copy of STR. (c) is the structure of the unintegrated linear double-stranded DNA intermediate with an LTR of at least 217 bp. I and T refer to the possible positions of the initiation and termination, respectively, of transcription of integrated viral DNA into RNA. R and B refer to possible RNA polymerase recognition and tight-binding sites, respectively, according to the model proposed by Doi for transcription (4).

of ASV of subgroup C, clone 35. Agar suspension colonies of transformed cells were obtained according to published procedures (5, 24). Briefly,  $10^6$  cells were placed in 4 ml of growth medium in 60-mm petri dishes and, after a few hours, were infected at various multiplicities from 0.001 to 0.1. After 7 to 10 h, the cells were trypsinized and diluted into 3 ml of soft agar, and the soft agar was poured into a 60-mm petri dish containing 2.5 ml of bottom agar. Beneath the bottom agar were  $10^6$  mitomycin C-treated (23) quail embryo fibroblasts as feeders. After 2 to 3 weeks, colonies were aspirated, transferred to 60-mm petri dishes, and grown as previously described (5). Those clones which grew to ca.  $4 \times 10^7$  cells were used for subsequent studies.

Mass-infected cultures were established by infecting  $10^6$  cells at a multiplicity of between 0.01 and 0.1 focus-forming unit per cell and passaging the cultures until all the cells were transformed.

**Isolation of cellular DNA.** Monolayer cultures of avian cells on 100-mm-diameter petri dishes were washed twice with 5 ml of STE (0.1 M NaCl, 0.02 M Tris-hydrochloride, 0.001 M EDTA, pH 7.4) and then digested in situ for 1 h at 37°C with 5 ml of STE containing 0.5% sodium dodecyl sulfate and 500  $\mu$ g of self-digested Pronase (Calbiochem) per ml. This solution was poured into a glass tube and extracted by gentle rocking for 10 min with an equal volume of

phenol. After chilling on ice for 5 min, the solution was centrifuged for 5 min at 5,000 rpm. The aqueous layer was removed with a 25-ml wide-mouth pipette and extracted a second time with phenol. Nucleic acids were precipitated from the aqueous layer by the addition of sodium acetate to a 0.2 M final concentration, followed by the addition of 2 volumes of 95% ethanol. The precipitated nucleic acid was collected by centrifugation, washed with 70% ethanol (to remove the salt), and suspended by gentle rocking in 2 ml of 0.01 M Tris-hydrochloride-0.01 M disodium EDTA, pH 7.4. After digestion for 1 h at 37°C with 100  $\mu$ g of boiled pancreatic RNase per ml, the remaining DNA was extracted with sodium dodecyl sulfate-Pronase, phenol extracted twice, and then collected by ethanol precipitation and centrifugation, all as described above. The DNA was resuspended in 0.1 mM disodium EDTA (pH 7.0) at a concentration of about 200  $\mu$ g/ml.

**Unintegrated ASV DNA intermediates.** Both circular and linear viral DNA intermediates were obtained as previously described (8) from monolayer cultures of the quail tumor line QT6 at 1 day after infection with ASV, either PrC or B77 strain. These intermediates were a generous gift from R. Guntaka, Columbia University. The fraction of linear intermediates also contains a small amount of relaxed circles (e.g., see Fig. 6a). Relative to PrC, the B77 strain intermediates contain a much greater proportion of transformation-defective (td) forms with respect to nondefective (nd) species. B77 strain intermediates were used in 4b, 6a, and 6b. In other cases we used PrC intermediates.

**Restriction endonuclease digestion.** Restriction enzymes were obtained commercially: *Pvu* I, *Kpn* I, and *Xho* I from New England Biolabs and *Eco*RI from Miles Laboratories, Inc. Digestions were carried out in a volume of 30  $\mu$ l for 1 h at 37°C. Before incubation, a 4- $\mu$ l sample was transferred to a separate tube containing 2,000 cpm of  $^{32}$ P-labeled phage lambda DNA (10). After incubation, the sample with lambda DNA was subjected to electrophoresis to determine whether the digestion had gone to completion. However, it was not excluded that although the digestion of lambda DNA was complete, the digestion of cell DNA might yet be incomplete.

**Electrophoresis.** Samples of 2 to 10  $\mu$ g and not more than 40  $\mu$ l were subjected to electrophoresis in horizontal slab gels (15 by 15 by 0.6 cm) of 0.7% agarose (Seakem) in the apparatus described by McDonnell et al. (13) and distributed by the Aquebogue Machine and Repair Shop (Long Island, N.Y.). Detection of virus-related sequences was carried out by the method of Southern (17), with modifications as previously described in detail (10). Briefly, the DNA in the gel was denatured with alkali and then neutralized, before transfer to a cellulose nitrate filter sheet. Hybridization was carried out at 68°C for 20 h with 5 ng of  $^{32}$ P-labeled complementary DNA (cDNA) per ml. Probe for viral sequences was made against 70S RNA, using reverse transcriptase and random oligonucleotide primers (10). Probe to quail 18S and 28S rRNA was prepared similarly. After hybridization, the filter was washed and subjected to autoradiography in the presence of an intensifying screen. The film obtained was scanned at 620 nm with a densitometer.

## RESULTS

From chicken, duck, and quail embryos we prepared monolayer cultures of uninfected and mass-infected cells, as well as transformed cell clones (17 chicken, 9 duck, 12 quail) derived by outgrowth of agar suspension colonies. Mass-infected cultures of chicken, duck, and quail cells were maintained for 7, 40, and 33 days, respectively. The DNA was extracted from the cultures and examined both before and after restriction enzyme digestion by electrophoresis on slab gels of 0.7% agarose. Viral sequences in the gel were detected by the method of Southern (17), using  $^{32}\text{P}$ -labeled cDNA probe (made with viral RNA as template) (10). Only representative data for the chicken, duck, and quail clones are presented. Before the state of integration of the viral DNA in the transformed cells was studied, it was first necessary to examine the cells for unintegrated viral DNA. We found that the mass-infected chicken and duck cultures contained significant amounts of unintegrated viral DNA, whereas the transformed clones did not. Mass infection with the B77 strain yielded more td forms with respect to nd genomes than did the PrA strain. In all of the undigested cellular samples, our cDNA probe also detected sequences that migrated equivalent to DNA species with molecular weights exceeding 30 megadaltons (Md) (data not shown). Evidence is presented later in this manuscript which excludes the possibility that unintegrated viral DNA intermediates were trapped and migrated with the high-molecular-weight DNA.

To examine the status of integrated viral DNA in transformed cells, we used previously obtained information regarding the sites of action of certain restriction enzymes on unintegrated ASV DNA intermediates (Fig. 2). As standards

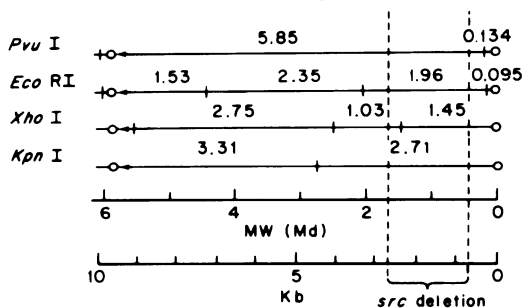
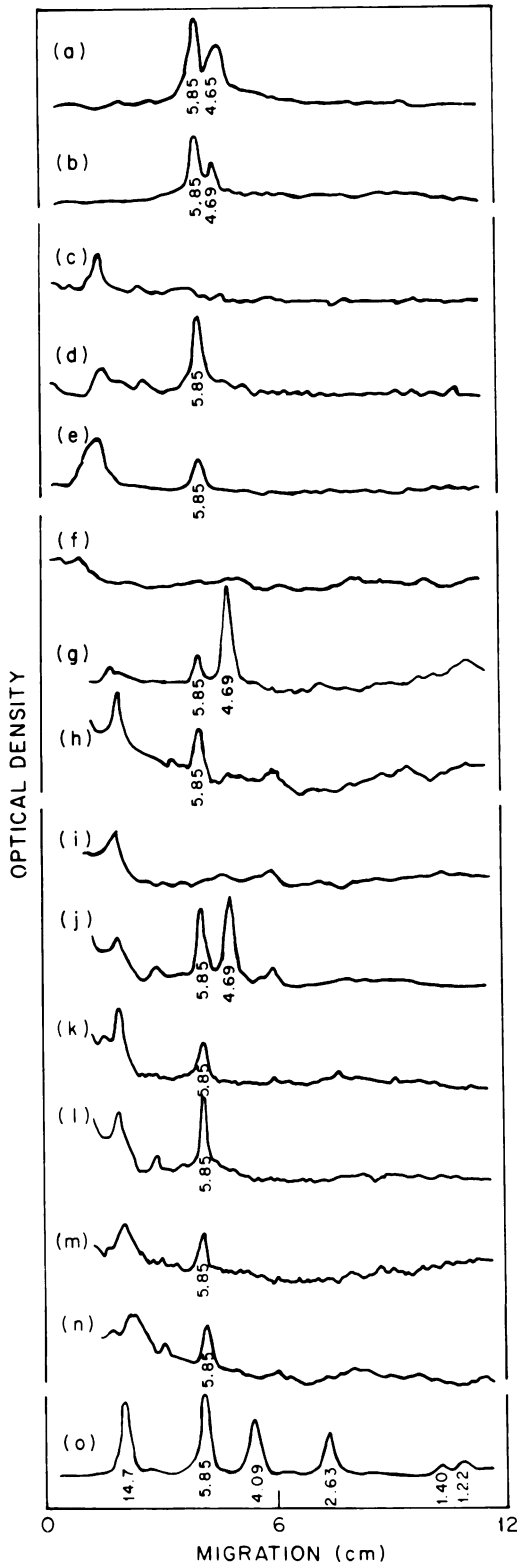

FIG. 2. Restriction enzyme sites on unintegrated double-stranded linear ASV DNA intermediates. This information is extracted from two previous papers (10, 20), and other conventions are as explained for Fig. 1. The numbers represent fragment sizes in Md. The approximate position of the 1.2-Md deletion of *src* is indicated by the broken lines and is based on studies of Lai et al. (11).

in the studies presented below, we analyzed in parallel the digestion products of unintegrated linear and circular intermediates (Fig. 3 through 6, panels a and b). It should be noted that the intermediates used contained not only the nd form, but also td forms which have about 1.2 Md deleted from the *src* region (Fig. 2 and reference 11).

First we considered the use of *Pvu* I, which is a powerful enzyme in this situation, since it only cuts in the LTR (Fig. 1 and 2). When the DNA of transformed chicken, duck, or quail cells was digested with *Pvu* I before electrophoresis, we obtained a fragment of about 5.85 Md. This fragment was released from mass-infected, as well as from transformed, cell clones, but not from uninfected cells (Fig. 3). It was the same size as the fragment released by *Pvu* I digestion of unintegrated linear or circular viral DNA intermediates (Fig. 3a and b). The *Pvu* I site was thus present twice, and the distance between the two sites was equal to that of the unit length species of 5.85 Md (Fig. 2 and reference 10). We concluded that there was not a significant permutation of viral sequences in integrated DNA relative to unintegrated viral DNA. We also concluded that at least part of each LTR sequence was maintained on the integrated viral DNA.

Additional evidence for these two conclusions was obtained by use of *Eco*RI. Like *Pvu* I, this enzyme makes one cut in the LTR, but, in addition, it makes two cuts in the unique viral sequence (Fig. 2). Digestion of linear and circular DNA intermediates with *Eco*RI yielded three internal fragments: 2.35, 1.96, and 1.53 Md (Fig. 4a and b). The 0.68-Md fragment seen in Fig. 4b arose as a consequence of the *src* deletion in the 1.96-Md fragment. Digestion with *Eco*RI of DNA from mass-infected and transformed clones of chicken, duck, and quail cells yielded the three internal fragments mentioned above (Fig. 4). Note that there was some variability in the relative amounts of these bands for different clones, for example, in Fig. 4k through n. This variability probably arose in the analysis procedure and was considered to be without biological significance. Nevertheless, these data did support the conclusions that the viral DNA was integrated without significant permutation relative to the linear DNA and also that at least part of each LTR sequence was maintained. It should be noted that uninfected chicken cells contained the 2.35-Md fragment. We interpreted this as being part of the related endogenous viral sequences (15). Also, the DNA of mass-infected duck and quail cells released a fragment of 0.68 Md that corresponds to the *src* deletion in the 1.96-Md band (Fig. 2).



The restriction endonuclease *Xho* I was used to obtain additional information on the status of integrated viral DNA. On unintegrated linear and circular viral DNA, this enzyme released two internal fragments: 2.75 and 1.03 Md (Fig. 5a and b). The same two fragments were released by *Xho* I from the transformed chicken, duck, and quail clones (Fig. 5). These data were consistent with the interpretation also made from the *Pvu* I and *Eco*RI studies, that the viral DNA was integrated without significant permutation. The 2.75-Md fragment was present in uninfected chick DNA and was interpreted as an endogenous viral sequence.

*Kpn* I makes only one cut on the viral DNA intermediates (Fig. 6a and b); therefore, it was expected that this enzyme would release junction fragments between cell and viral DNA for each transformed clone. For the DNA from each of 12 transformed quail clones, this enzyme released unique cell-virus fragments. Data for four clones are shown in Fig. 6k through n. There was a fragment of 5.25 Md common to all quail clones, mass-infected cells (Fig. 6j), and uninfected cells (Fig. 6i). D. Spector has evidence that this fragment of quail DNA contains endogenous *src*-related sequences (18; personal communication).

The transformed chicken and duck clones were different from the quail clones in that *Kpn* I digestion did not release unique cell-virus junction fragments. We examined 17 chicken and 9 duck clones of transformed cells. Representative data are shown in Fig. 6e and h. Possible reasons for this are considered below.

If the clones of transformed cells contained two genomes in tandem, then digestion of the

FIG. 3. Agarose gel electrophoresis of avian cell DNA after digestion with *Pvu* I. Samples were subjected to electrophoresis for 16 h at 0.8 V/cm on a gel of 0.7% agarose, after which viral sequences were detected by the method of Southern (17). The autoradiograms obtained were scanned for optical density. Cell DNA samples in (a) through (n) were 2 to 10  $\mu$ g and were digested with *Pvu* I before electrophoresis. (a) Total unintegrated linear ASV DNA intermediates; (b) total unintegrated circular ASV DNA intermediates; (c) uninfected chicken embryo fibroblast DNA; (d) mass-infected chicken (PrA); (e) clone of transformed chicken (PrA); (f) uninfected duck; (g) mass-infected duck (B77); (h) clone of transformed duck (B77); (i) uninfected quail; (j) mass-infected quail (B77); (k) quail clone (PrA no. 14); (l) quail clone (B77 no. 7); (m) quail clone (B77 no. 8); (n) quail clone (B77 no. 11); (o) *Hind*III fragments of  $^{32}$ P-labeled phage lambda DNA were used as molecular weight markers, and deduced molecular weights for relevant peaks are indicated in Md (the uncertainty in these molecular weight estimates is about 5%).

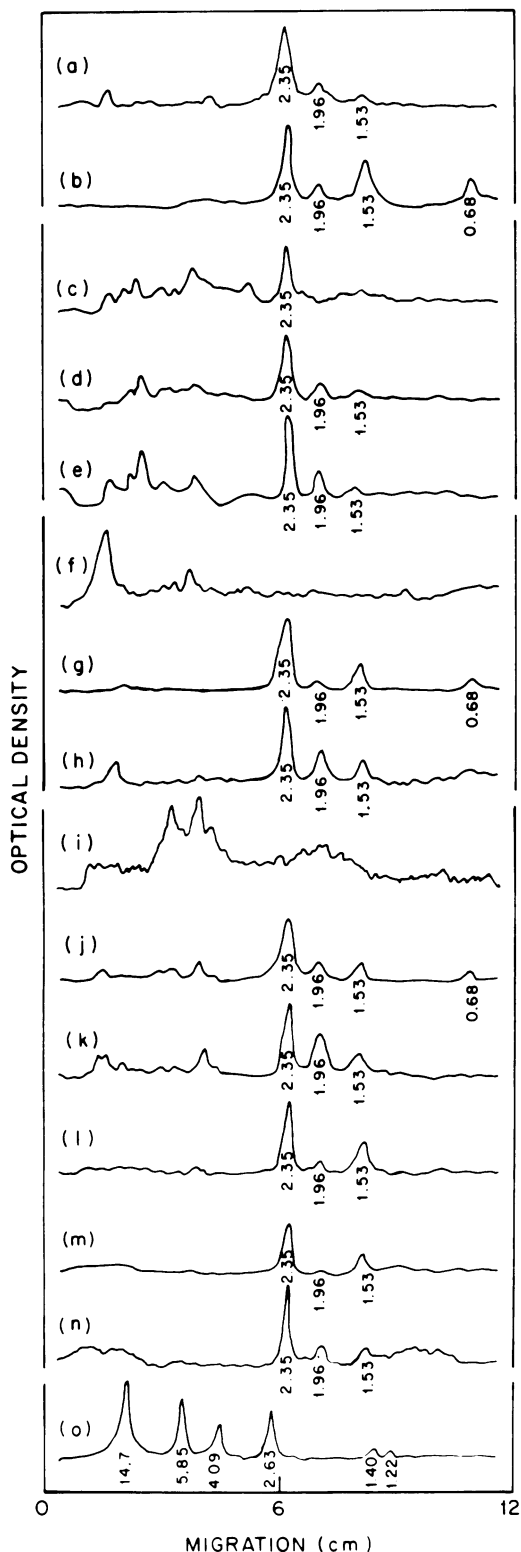

DNA with *Kpn* I would release the unit length genome of 5.85 Md. This was not observed. The *Kpn* I digest also provided additional evidence that unintegrated viral DNA intermediates were not present in the transformed cell clones. *Kpn* I would have released unit length molecules from circular intermediates and specific fragments from linear intermediates. For the DNA of the transformed clones, neither the unit length molecules nor the specific fragments (3.31 and 2.71 Md) were observed.

In many of the tracings shown in Fig. 3 through 6, there are regions of optical density that have not been referred to in the above text. Control experiments were performed to test for cellular rDNA fragments. That is, if our  $^{32}\text{P}$ -labeled cDNA probe contained even 1% of sequences related to rRNA, then because rDNA is repeated at least 100-fold in animal cells (19), such DNA would have been detected with as much efficiency as unique viral DNA sequences. Therefore, after autoradiography and sufficient time to allow for  $^{32}\text{P}$  decay, the cellulose nitrate filters used in the experiments shown in Fig. 3 through 6 were reannealed with a  $^{32}\text{P}$ -labeled probe made against quail rRNA. Representative data for chicken, duck, and quail DNA digested with *Pvu* I, *Eco*RI, *Xho* I, and *Kpn* I are presented in Fig. 7. Some of the previously undiscussed bands of Fig. 3 through 6 are actually ribosomal. For example, in Fig. 3d through e, there is a chicken rDNA band of 17.95 Md which was labeled by our cDNA probe made against viral RNA. In Fig. 8, we present a direct comparison of *Pvu* I fragments as detected with an ASV probe with respect to a rehybridization with an rRNA probe. More recently we have found that most of the labeling of bands by contaminants in the ASV cDNA probe can be competed out by the presence of 4 mg of heat-denatured total quail embryo nucleic acid per ml during hybridization.

## DISCUSSION

From the studies described here, we have concluded that integration of viral DNA involved a specific site on that viral DNA. We have not detected any specificity with respect to the site of integration on the host DNA. The earlier studies by Collins and Parsons (2) of ASV-transformed mammalian cells are consistent with these conclusions.

Our evidence for a specific site of integration on the viral DNA intermediate has come mainly

FIG. 4. Agarose gel electrophoresis of avian cell DNA after digestion with *Eco*RI. Legend as for Fig. 3.

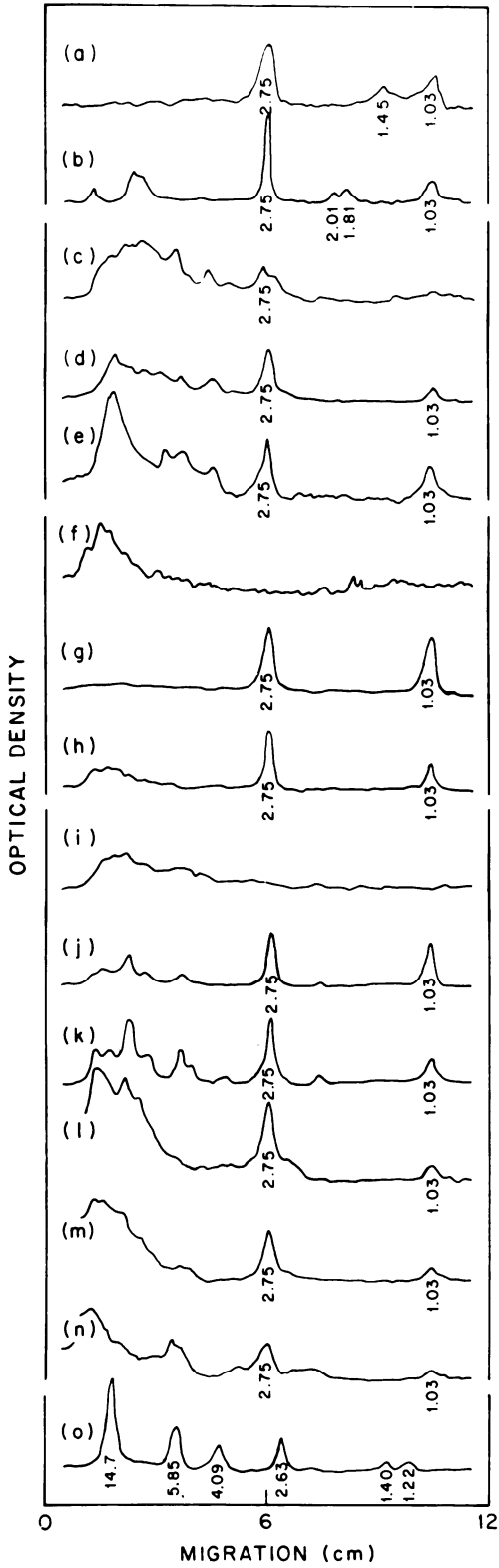

FIG. 5. Agarose gel electrophoresis of avian cell DNA after digestion with *Xho* I. Legend as for Fig. 3.

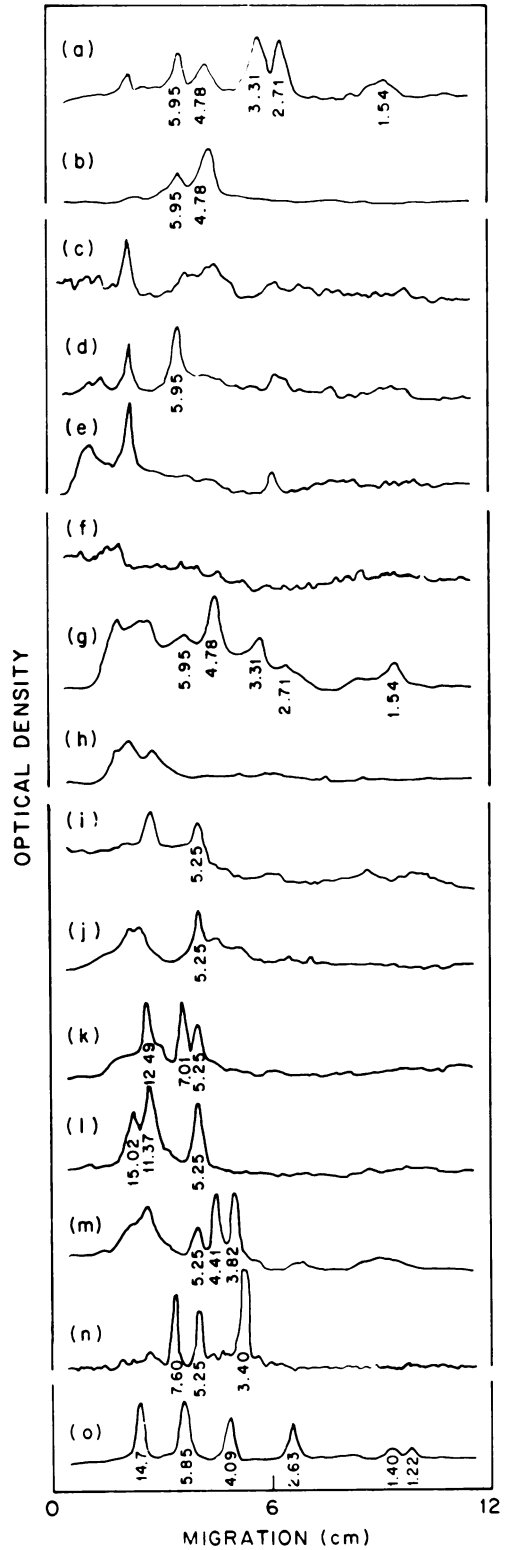

FIG. 6. Agarose gel electrophoresis of avian cell DNA after digestion with *Kpn* I. Legend as for Fig. 3.

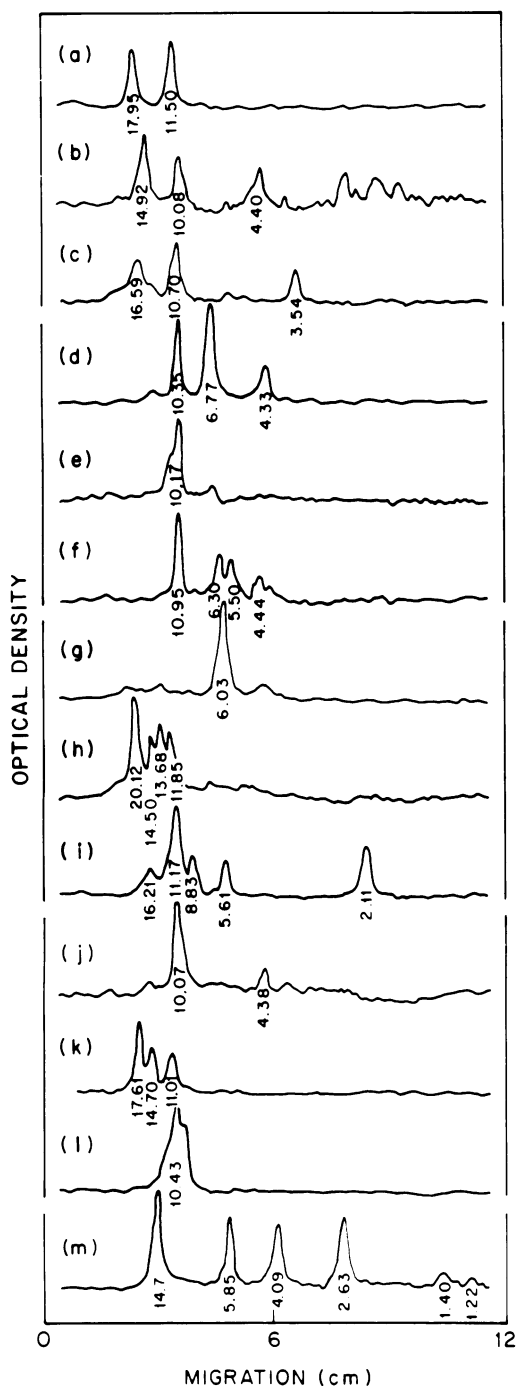

FIG. 7. Agarose gel electrophoresis of digested avian cell DNA followed by Southern analysis with a probe to rDNA. Samples were subjected to digestion, electrophoresis, and Southern transfer (17) as in Fig. 3 through 6, with the exception that the labeled probe was to quail rRNA. (a to c) *Pvu* I of chicken, duck, and quail DNA, respectively; (d to f) *Eco*RI of

from the use of the endonuclease *Pvu* I. This enzyme cleaves at a site approximately 217 bases from the right-hand side of the in vivo linear DNA intermediates, and, as we have previously documented (10), makes a second cut at the left side of those intermediates because of a direct repeat, LTR, on the left side of the right-hand-side sequences, including the *Pvu* I site. In the present study we have seen that the integrated viral DNA also possessed what seemed to be the same *Pvu* I site at each end, as shown in Fig. 1c. The viral sequences between the two LTRs were not permuted during integration. This indicated a significant amount of specificity with respect to the site on the viral intermediate, be it circular or linear, at which integration occurs.

Our data have not allowed us to say whether all of the two LTRs observed on the unintegrated DNA intermediate were maintained on the integrated DNA. Nucleotide sequencing will be needed to resolve this question. On the left side of the integrated viral DNA, the *Pvu* I site, which is 0.134 Md into the LTR, was maintained. On the right side, all we can say is that the *Pvu* I and the *Eco*RI sites were maintained.

At our level of analysis, we have been unable to detect any specificity in the site on the host cell at which integration occurs. With *Kpn* I, we have detected unique cell-virus junction fragments for 12 transformed quail clones. However, with transformed chicken and duck clones we have been unable to detect any junction fragments. An obvious trivial explanation of this might be that many integration events have occurred in such cells. Considering that the clones were generated by an initial low multiplicity of infection, extra copies could have arisen by subsequent reinfection(s). If this had happened, we might have expected at least the original genome to be at the same location in each cell, and it would therefore have been detected. Our interpretation as to why cell-virus junction fragments have not been found is that during the outgrowth of the clone from a single cell some heterogeneity occurred in the cell-virus junctions. Since *Pvu* I makes two cuts on the integrated viral DNA and releases a unit length genome fragment from each clone, the heterogeneity must, therefore, have been in the cellular sequences adjacent to the viral DNA. This het-

chicken, duck, and quail DNA, respectively; (g to i) *Xho* I of chicken, duck, and quail DNA, respectively; (j to l) *Kpn* I of chicken, duck, and quail DNA, respectively; (m) *Hind*III fragments of  $^{32}$ P-labeled phage lambda DNA were used as molecular weight markers, and deduced molecular weights for relevant peaks are indicated in Md.

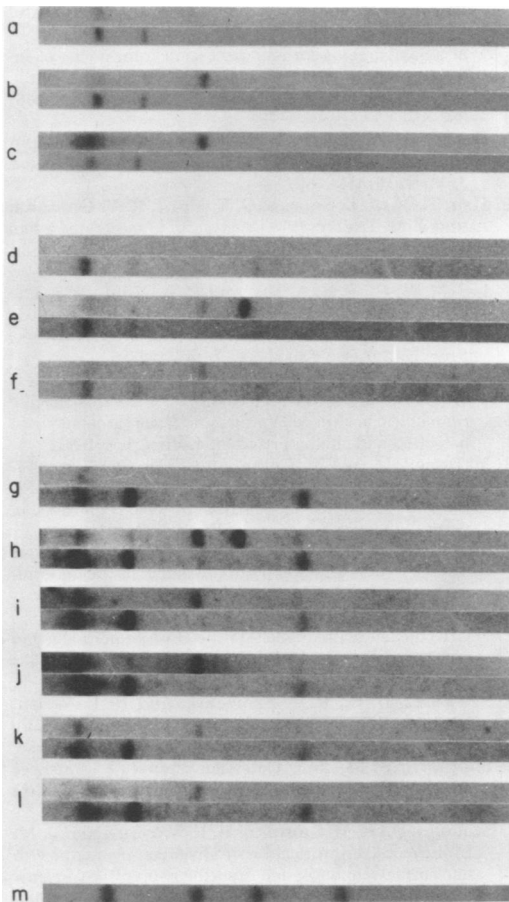

FIG. 8. Agarose gel electrophoresis of avian cell DNA after digestion with *Pvu* I. Samples were subjected to digestion and electrophoresis as explained for Fig. 3. The DNA was transferred to a cellulose nitrate filter and subjected to hybridization with a  $^{32}\text{P}$ -labeled DNA probe to ASV RNA and subsequent autoradiography and scanning. (a) After suitable decay of the  $^{32}\text{P}$ , the filter was rehybridized, this time with a  $^{32}\text{P}$ -labeled DNA probe to quail rRNA, and again followed by autoradiography. For (a) through (l), the upper and lower lanes refer to autoradiograms obtained with ASV and rRNA probes, respectively. The autoradiographs in the upper lanes of (a) through (l) were used to obtain the densitometer tracings presented in Fig. 3c through n. (a) Uninfected chicken embryo fibroblast DNA; (b) mass-infected chicken (PrA); (c) clone of transformed chicken (PrA); (d) uninfected duck; (e) mass-infected duck (B77); (f) clone of transformed duck (B77); (g) uninfected quail; (h) mass-infected quail (B77); (i) quail clone (PrA no. 14); (j) quail clone (B77 no. 7); (k) quail clone (B77 no. 8); (l) quail clone (B77 no. 11); (m) *Hind*III fragments of  $^{32}\text{P}$ -labeled phage lambda DNA.

erogeneity could have been generated by movement or translocation of the viral sequences or by rearrangement of the adjacent cell sequences.

These two possibilities are considered further below.

In Fig. 1c, the direction of transcription of new viral RNA from integrated viral DNA would be from the left moving right. From the structure of the viral RNA (Fig. 1a), we can see that termination of transcription occurs at a point T, just beyond the STR, after which poly(A) is added. We would like to make inferences about the site of initiation of transcription. If there are no precursors to viral RNA, then transcription of integrated DNA into RNA starts at I, as indicated in Fig. 1c. Fan and Baltimore have looked at the viral RNA of cells infected with RNA tumor viruses and have been unable to detect transcripts greater than genome size (6), although two laboratories have claimed to have found precursors (9, 12). Studies of transcription in procaryotes have established that there are untranscribed DNA sequences upstream from the initiation site I, which the RNA polymerase recognizes and binds to (4). We have shown that integrated viral DNA has two copies of LTR; thus, the virus can afford to use one of these as the source of such essential, but untranscribed, sequences.

The organization of integrated viral DNA as a unique sequence flanked by direct repeats of a relatively smaller sequence, in this case the LTR, is structurally analogous to what has been found for transposable elements of procaryotes (as reviewed in reference 1). The analogy maybe goes further. First, for some transposons the flanking repeats (direct or inverted) can function in the initiation and termination of the transcription of RNA. Second, the repeats can also facilitate the integration and transposition of the element. At our level of analysis, the site on the ASV DNA at which integration occurs seems to be also delineated by the LTR. It is possible, but not established, that in the chicken and duck clones we have detected the consequences of transposition of integrated viral DNA during outgrowth of the clone. Another interpretation, also suggested by studies with transposable elements, is that insertions and deletions of sequences can occur at regions adjacent to the flanking repeat (D. Bottstein and N. Kleckner in reference 1).

The integrated viral DNA with flanking LTR is also analogous to certain *Drosophila* DNA sequences cloned by Finnegan et al. (7). They have characterized two families of genes, each of which is expressed as mRNA in polysomes and each of which exists at the DNA level flanked by specific direct terminal repeats of 300 and 500 bp, respectively. It may be that direct terminal repeats flanking structural genes are of major importance in the organization of the genomes



of eucaryotic and procaryotic cells. It may be relevant that the studies of Davidson (3) have established that in most metazoan species many of those structural genes that can be detected as functional mRNA's in polysomes can be shown to exist at the DNA level in the so-called *Xenopus* pattern, with the structural gene flanked by moderately repeated sequences of an average 300 bp. With recombinant DNA technology it should soon be possible to know how frequently genes have flanking sequences that are identical.

#### ACKNOWLEDGMENTS

We thank R. Guntaka for providing us with unintegrated viral DNA intermediates used as controls in these studies. E. Hunter (Birmingham, Ala.) provided B77 clone 35. M. Linial (Seattle, Wash.) and P. Vogt (Los Angeles, Calif.) provided helpful suggestions on the growth of transformed cell clones.

J.M.T. and W.S.M. were supported by American Cancer Society grants VC-155B and NP-241, respectively, and also by Public Health Service institutional grants CA-06927 and RR-05539 from the National Cancer Institute and the Division of Research Resources, NIH, respectively, and an appropriation from the Commonwealth of Pennsylvania. W.S.M. was also supported by Public Health Service grant CA-16641 from the National Cancer Institute.

Purified reverse transcriptase from avian myeloblastosis virus and fertile quail eggs were kindly provided by the Office of Program Resources and Logistics, Viral Cancer Program, Bethesda, Md.

#### LITERATURE CITED

- Bukhari, A. I., J. A. Shapiro, and S. L. Adhya (ed.). 1977. DNA insertion elements, plasmids, and episomes. Cold Spring Harbor Laboratory, Cold Spring Harbor, N.Y.
- Collins, C. J., and J. T. Parsons. 1977. Integration of avian sarcoma virus DNA sequences in transformed mammalian cells. *Proc. Natl. Acad. Sci. U.S.A.* **74**:4301-4305.
- Davidson, N. 1976. Gene activity in early development. Academic Press Inc., New York.
- Doi, R. H. 1977. Role of ribonucleic acid polymerase in gene selection in procaryotes. *Bacteriol. Rev.* **41**:568-594.
- Duesberg, P. H., and P. K. Vogt. 1973. RNA species obtained from clonal lines of avian sarcoma and from avian leukemia virus. *Virology* **54**:207-219.
- Fan, H., and D. Baltimore. 1973. RNA metabolism of murine leukemia virus: detection of virus-specific RNA sequences in infected and uninfected cells and identification of virus-specific messenger RNA. *J. Mol. Biol.* **80**:93-117.
- Finnegan, D. J., G. M. Rubin, M. W. Young, and D. S. Hogness. 1978. Repeated gene families in *Drosophila melanogaster*. Cold Spring Harbor Symp. Quant. Biol. **42**:1053-1063.
- Guntaka, R. V., O. C. Richards, P. R. Shank, H. J. Kung, N. Davidson, E. Fritsch, J. M. Bishop, and H. E. Varmus. 1976. Covalently closed circular DNA of avian sarcoma virus: purification from nuclei of infected quail tumor cells and measurement by electron microscopy and gel electrophoresis. *J. Mol. Biol.* **106**:337-357.
- Haseltine, W. A., and D. Baltimore. 1976. Size of murine RNA tumor virus-specific nuclear RNA molecules. *J. Virol.* **19**:331-337.
- Hsu, T. W., J. L. Sabran, G. E. Mark, R. V. Guntaka, and J. M. Taylor. 1978. Analysis of unintegrated avian RNA tumor virus double-stranded DNA intermediates. *J. Virol.* **28**:810-818.
- Lai, M. M. C., S. S. A. Hu, and P. K. Vogt. 1977. The occurrence of partial deletion and substitution of the *src* gene in the RNA genome in avian sarcoma viruses. *Proc. Natl. Acad. Sci. U.S.A.* **74**:4781-4785.
- Leong, J. A., A. C. Garapin, N. Jackson, L. Fanshier, W. Levinson, and J. M. Bishop. 1972. Virus-specific ribonucleic acid in cells producing Rous sarcoma virus: detection and characterization. *J. Virol.* **9**:891-902.
- McDonnell, M. W., N. Simon, and F. W. Studier. 1977. Analysis of restriction fragments of T7 DNA and determination of molecular weights by electrophoresis in neutral and alkaline gels. *J. Mol. Biol.* **110**:119-146.
- Mason, W. S., and C. Yeater. 1977. A mutant of Rous sarcoma virus with a conditional defect in the determinant(s) of viral host range. *Virology* **77**:443-456.
- Nieman, P. E. 1973. Measurement of endogenous leukemia virus nucleotide sequences in the DNA of normal avian embryos by RNA-DNA hybridization. *Virology* **53**:196-204.
- Schwartz, D. E., P. C. Zamecnik, and H. L. Weith. 1977. Rous sarcoma virus is terminally redundant: the 3' sequence. *Proc. Natl. Acad. Sci. U.S.A.* **74**:994-998.
- Southern, E. M. 1975. Detection of specific sequences among DNA fragments separated by gel electrophoresis. *J. Mol. Biol.* **98**:503-517.
- Stehelin, D., R. V. Guntaka, H. E. Varmus, and J. M. Bishop. 1976. Purification of DNA complementary to nucleotide sequences required for neoplastic transformation of fibroblasts by avian sarcoma viruses. *J. Mol. Biol.* **101**:349-365.
- Tartof, K. 1975. Redundant genes. *Annu. Rev. Genet.* **9**:355-385.
- Taylor, J. M., T. W. Hsu, and M. M. C. Lai. 1978. Restriction enzyme sites on the avian RNA tumor virus genome. *J. Virol.* **26**:479-484.
- Taylor, J. M., T. W. Hsu, J. L. Sabran, M. M. C. Lai, R. V. Guntaka, and W. S. Mason. 1978. Avian sarcoma virus replication: location of restriction enzyme sites on unintegrated and integrated viral DNA. *J. Supramol. Struct., Suppl.* **2**, p. 257.
- Weinberg, R. 1977. Synthesis of the intermediates leading to the integrated provirus. *Biochim. Biophys. Acta* **473**:39-45.
- Weiss, R. A., W. S. Mason, and P. K. Vogt. 1978. Genetic recombinants and heterozygotes derived from endogenous and exogenous avian RNA tumor viruses. *Virology* **52**:535-552.
- Wyke, J. A., and M. Linial. 1973. Temperature sensitive avian sarcoma virus: a physiological characterization of twenty mutants. *Virology* **53**:152-161.