

## Supplemental Figures

### Figure S1

(A) HSD3B1 positive Leydig cell number in WT (n=3) and *Lhb*<sup>-/-</sup> mice injected with PBS (n=3), hCG (n=3) or osteocalcin (3ng/g/day) (n=3). The count of the HSD3B1 positive Leydig cells was performed on 30 sections for each conditions (Scale bar, 100µm). (B) Analysis of 2 week-old *Lhb*<sup>-/-</sup> male mice injected for one month with PBS (n=5), osteocalcin (3ng/g/day) (n=5) or hCG (Human Chorionic Gonadotrophin) (5UI twice a week) (n=5). Immunofluorescence, using anti-Cyp17, anti-3b-HSD or anti-Cyp11a antibodies as markers of mature Leydig cells. All of the analyses were performed on nonbreeder C57BL/6J mice. (C) Circulating LH levels in WT and Osteocalcin<sup>-/-</sup> mice untreated or treated with hCG (5UI twice a week) (n=7 for each groups).

### Figure S2

(A) In situ hybridization of *Gprc6a* performed in testis (Scale bar, 200µm), pituitary gland (Scale bar, 500µm) and hypothalamus (Scale bar, 500µm) in WT and *Gprc6a*<sup>-/-</sup> mice. (B) qPCR analysis of *Gprc6a* expression level in WT and *Gprc6a*<sup>-/-</sup> pancreas, kidney, testis, hypothalamus and pituitary gland.

### Figure S3

(A-C) qPCR analysis of (A) *Osteocalcin*, (B) *Gamma-glutamyl carboxylase (Ggcx)* and (C) *Vitamin K epoxide reductase complex, subunit 1 (Vkorc1)* in differentiated

osteoblasts treated for 4 hours with vehicle, 100UI, 10UI, 3UI, 1UI and 0.3UI of hCG for 4 hours.

### Figure S4

(A) *Ctsk-Cre;DTA<sup>fl/+</sup>* mice developed a classical osteopetrosis phenotype characterized by very dense bone on X-ray images and an absence of incisors eruption due to a severe impairment in bone resorption. (B) Sperm counts, (C) seminal vesicle weight normalized to body weight (mg/g of BW), (D) circulating testosterone levels in *Ctsk-Cre;DTA<sup>fl/+</sup>* male mice injected with vehicle (n=5) or osteocalcin (3ng/g/day) (n=5). All analyses were performed on nonbreeder C57BL/6J mice.

### Figure S5

(A) Measurement of the uncarboxylated (GLU-OCN), carboxylated (GLA13-OCN), total (Total-OCN) and undercarboxylated (GLU13-OCN) forms of osteocalcin in serum of WT (n=12), *Opg*<sup>+/-</sup> (n=10), *Osteocalcin*<sup>+/-</sup> (n=3) and *Osteocalcin*<sup>+/-</sup>; *Opg*<sup>+/-</sup> (n=6) mice at 12-weeks of age. The data are represented in % versus WT serum.

### Figure S6

(A) Schematic representation of the amino acid sequence containing the substitution. This region is highly conserved in several species and the amino acid mutated in the patients is

highlighted in red. (B) Family tree of the patient originating from Togo. (C) Family tree of the patient originating from Senegal. **●** indicates female and **□** indicates male. The arrow designated the propositus who carries the F464Y mutation on the osteocalcin receptor *GPRC6A* and presents a severe oligospermia due to peripheral hypogonadism.

### Figure S7

(A) Western blot analysis of MYC in HEK293T cells transfected with GPRC6A-pcDNA3 or GPRC6A mutant-pcDNA3. Beta-tubulin has been used as a loading control.

### Figure S8

(A-B) Testis pictures of all of the models presented in this paper. (A) Testis of control, *Ctsk-Cre;DTA<sup>fl/+</sup>* and *Ctsk-Cre;DTA<sup>fl/+</sup>* injected with osteocalcin (3ng/g/ day during 1 month) versus WT male mice. (B) Testis of control, *Opg<sup>-/-</sup>* and *Opg<sup>+/-</sup>* mice. (C) Testis of control and *InsR<sub>osb</sub><sup>+/-</sup>; Osteocalcin<sup>+/-</sup>* mice. (D) Testis of control and *InsR<sub>osb</sub><sup>+/-</sup>; Gprc6a<sup>+/-</sup>* mice.

### Supplemental Table 1

Table containing the values of the sperm count (million/ml) of the patient with cryptochidy.

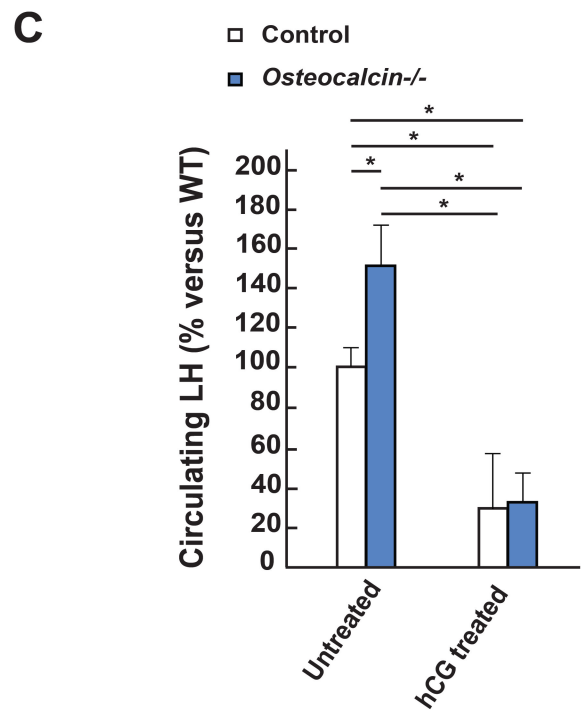
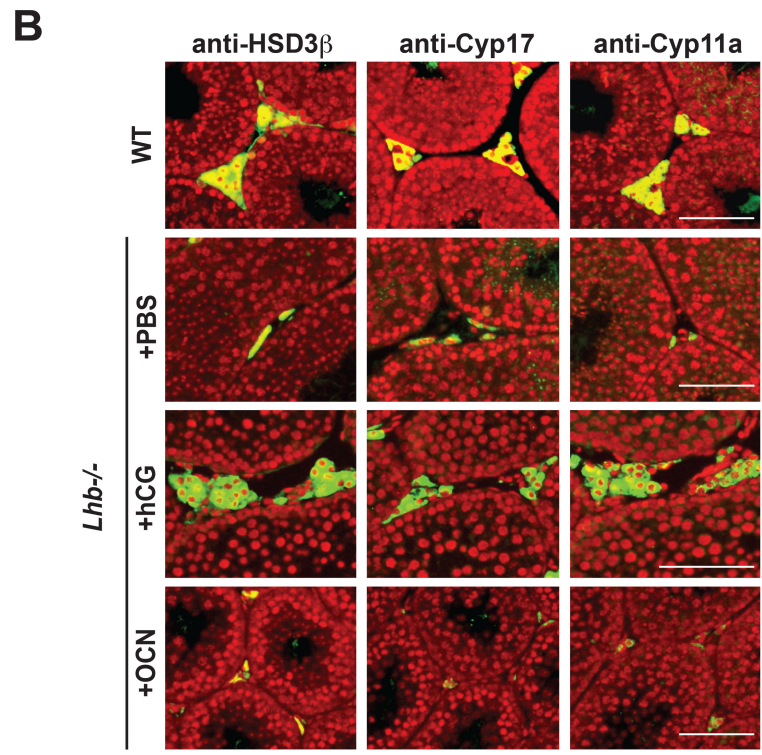
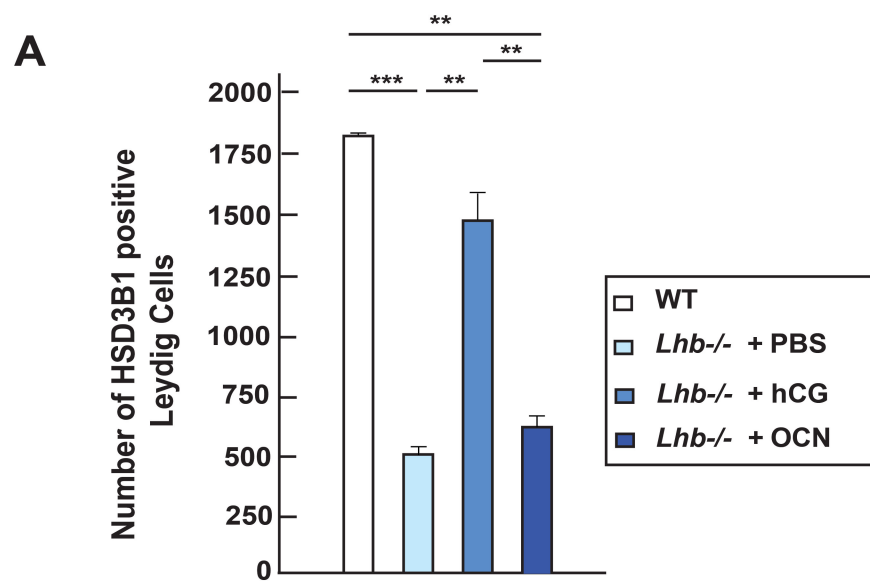
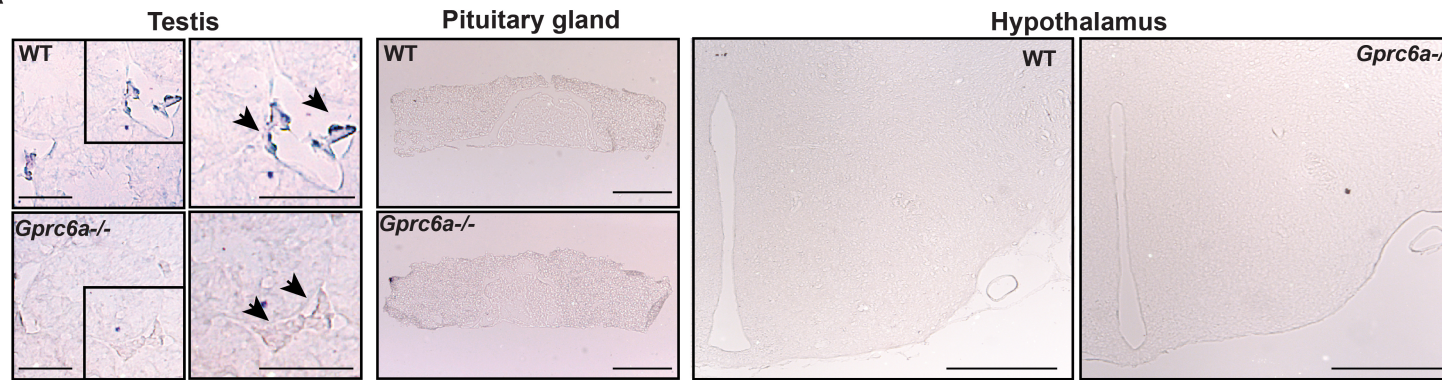
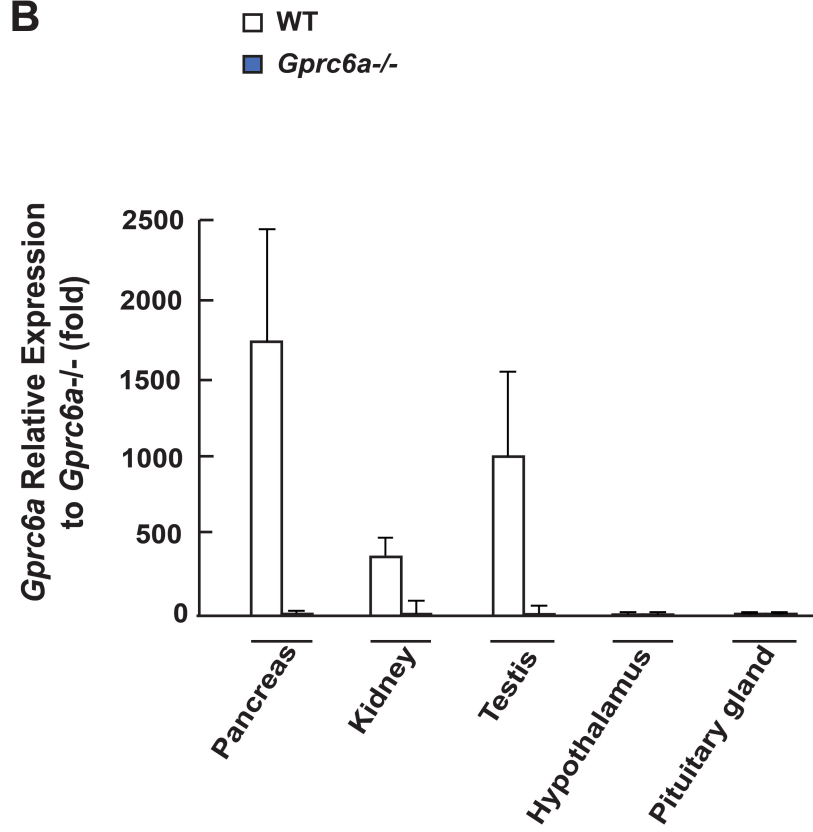
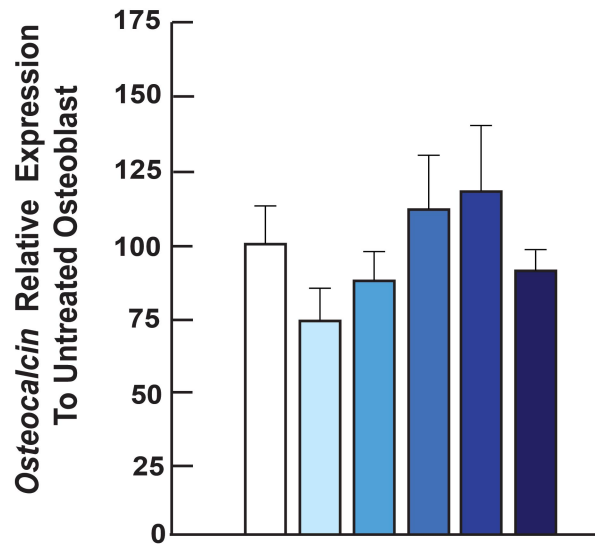
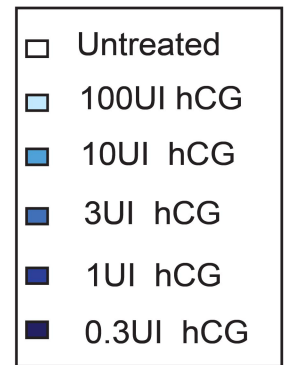
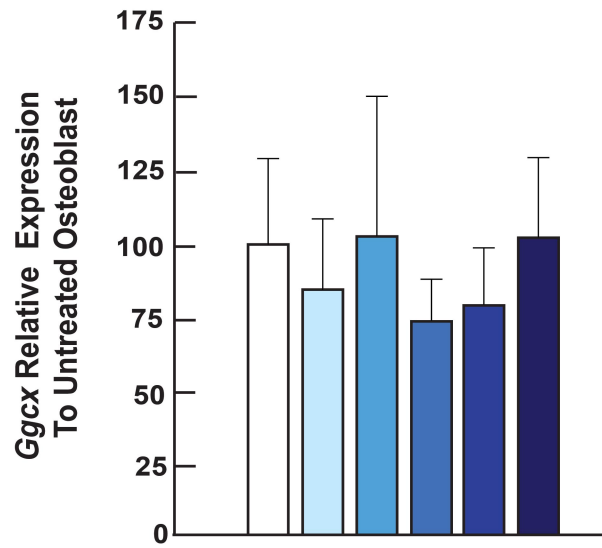
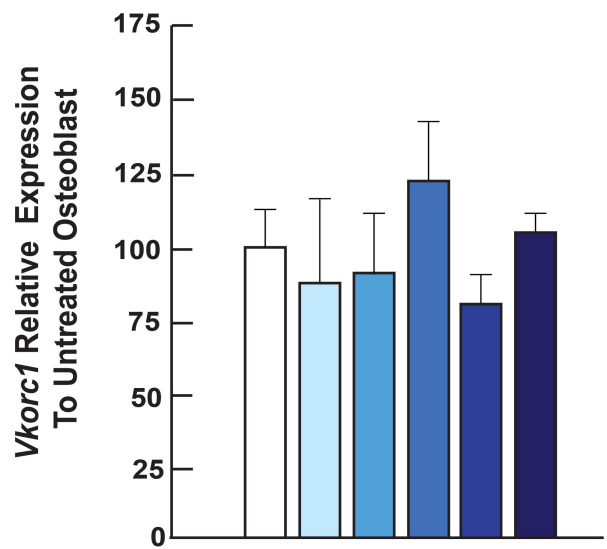

Figure S1

**A****B****Figure S2**

**A****B****C****Figure S3**

**A**

**Control**



*Ctsk-cre;DTA<sup>fl/+</sup>*



**B**

**Seminal Vesicle Weight  
(mg/BW)**

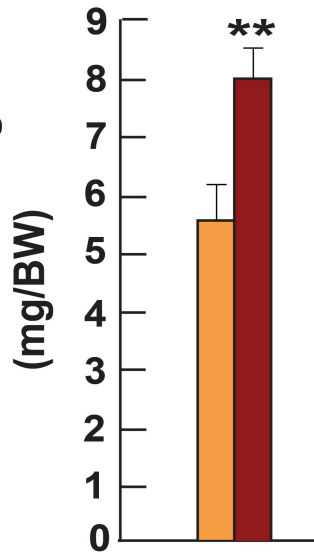

**C**

**Sperm Count ( $10^6$ )**

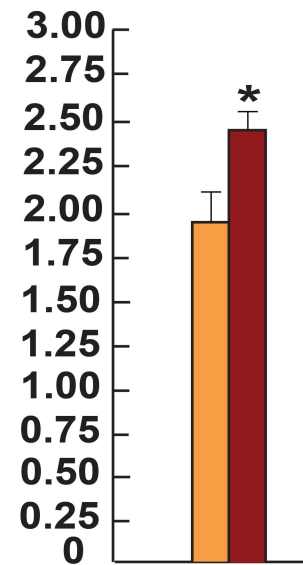

**D**

**Circulating Testosterone  
(ng/ml)**

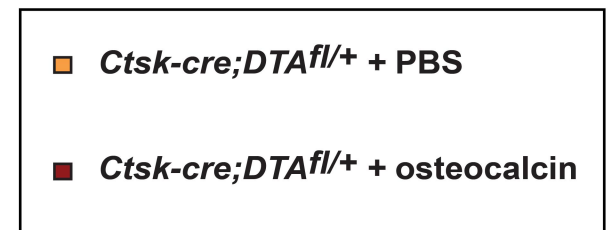
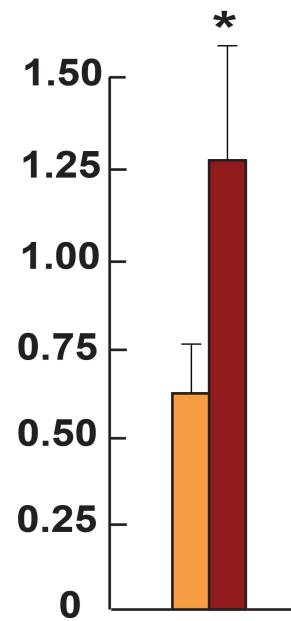

**Figure S4**

**A**

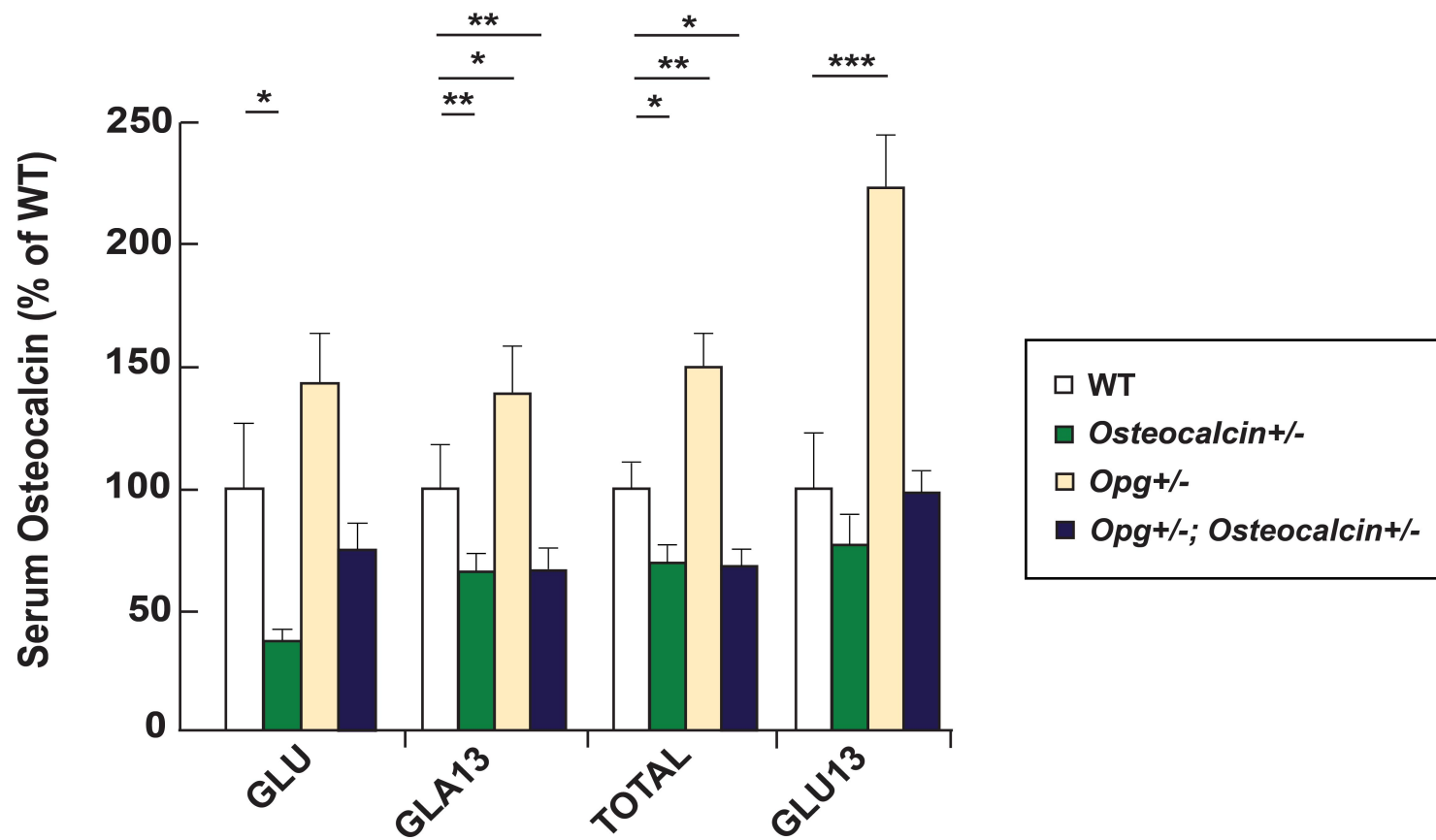
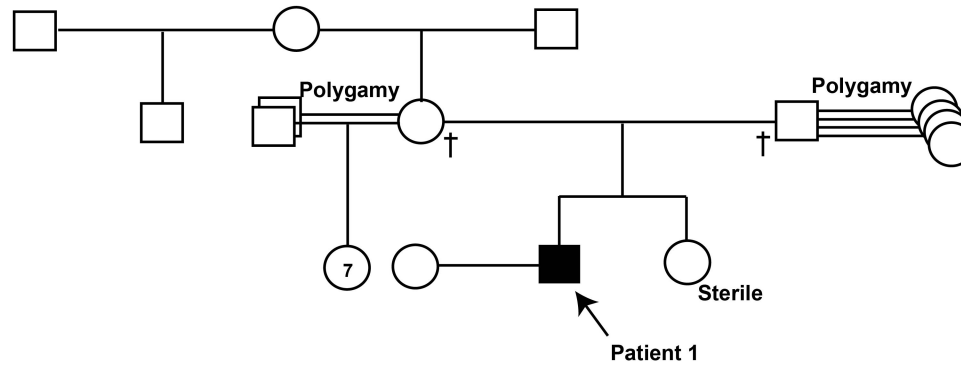
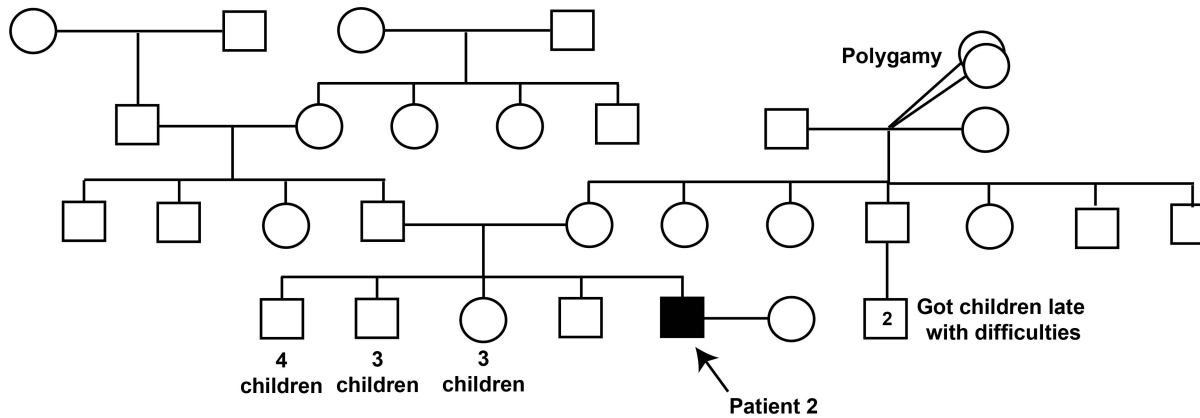

**Figure S5**



**A**

|                        |                             | <b>464</b> |   |          |   |     |
|------------------------|-----------------------------|------------|---|----------|---|-----|
| Homo sapiens           | <a href="#">NP 683766.2</a> | 444        | W E L L G V L K N V T F T D G W N S F H | <b>F</b> | DA H G D L N T G Y D V V L W K - E I N G H M T  | 487 |
| Pan troglodytes        | <a href="#">XP 527484.2</a> | 444        | W E L L C V L K N V T F T D C W N S F H | <b>F</b> | DA H C D L N T G Y D V V L W K - E I N G H M T  | 487 |
| Canis lupus familiaris | <a href="#">XP 541212.1</a> | 444        | W E L L D V L K N V T F T D E C N S F H | <b>F</b> | DA H C D M N T G Y D V V L W K - E I C G H M T  | 487 |
| Mus musculus           | <a href="#">NP 694711.1</a> | 444        | W E L L A V L K N V T F T D C R N S F H | <b>F</b> | DA H C D L N T G Y D V V L W K - E T N C L M T  | 487 |
| Rattus norvegicus      | <a href="#">XP 228164.3</a> | 444        | W E L L A V L K N V T F T D G K N S F H | <b>F</b> | DA H G D L N T G Y E V V L W K - E T N G L M T  | 487 |
| Danio rerio            | <a href="#">XP 426177.2</a> | 441        | W E L L E E L K K V T I I D D D K E I H | <b>F</b> | D S K G D L S S G Y D V V L W K - E V D G R M E | 484 |

**B****C****Figure S6**

**A**

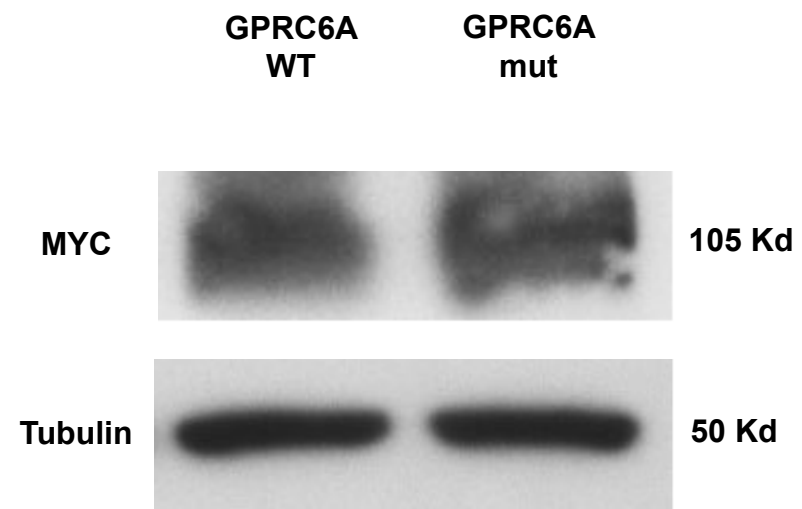

**Figure S7**

**A**



*Control*

*Ctsk-cre;DTAfl/+*

*Ctsk-cre;DTAfl/+*  
*osteocalcin injected*

**B**



*Control*

*Opg-/-*

*Opg+/-*

**C**



*Control*

*InsRosb fl/+;*  
*Ocn+/-*

**D**



*Control*

*InsRosb fl/+;*  
*Gprc6a+/-*

**Figure S8**

|           | Date of birth | Sperm count<br>(million/ml) |      |
|-----------|---------------|-----------------------------|------|
| Patient 1 | 09/01/1964    | 12.0                        |      |
| Patient 2 | 01/11/1977    | 51.0                        |      |
| Patient 3 | 07/05/1975    | 2.7                         |      |
| Patient 4 | 03/17/1982    | 8.5                         |      |
| Patient 5 | 08/18/1981    | 34.0                        |      |
| Patient 6 | 02/02/1971    | 20.0                        |      |
| Patient 7 | 05/26/1984    | 4.6                         |      |
| Patient 8 | 02/06/1973    | 18.6                        |      |
| Patient 9 | 03/17/1982    | 8.8                         |      |
|           |               | <b>17.8</b>                 | Mean |

**Supplemental Table 1**