

Tissue-Specific and Developmentally Regulated Expression of a Chimeric Actin-Globin Gene in Transgenic Mice

MOSHE SHANI

Department of Cell Biology, The Weizmann Institute of Science, Rehovot 76100, Israel

Received 30 January 1986/Accepted 14 April 1986

A chimeric plasmid containing about 2/3 of the rat skeletal muscle actin gene plus 730 base pairs of its 5' flanking sequences fused to the 3' end of a human embryonic globin gene (D. Melloul, B. Aloni, J. Calvo, D. Yaffe, and U. Nudel, EMBO J. 3:983-990, 1984) was inserted into mice by microinjection into fertilized eggs. Eleven transgenic mice carrying the chimeric gene with or without plasmid pBR322 DNA sequences were identified. The majority of these mice transmitted the injected DNA to about 50% of their progeny. However, in transgenic mouse CV1, transmission to progeny was associated with amplification or deletion of the injected DNA sequences, while in transgenic mouse CV4 transmission was distorted, probably as a result of insertional mutagenesis. Tissue-specific expression was dependent on the removal of the vector DNA sequences from the chimeric gene sequences prior to microinjection. None of the transgenic mice carrying the chimeric gene together with plasmid pBR322 sequences expressed the introduced gene in striated muscles. In contrast, the six transgenic mice carrying the chimeric gene sequences alone expressed the inserted gene specifically in skeletal and cardiac muscles. Moreover, expression of the chimeric gene was not only tissue specific, but also developmentally regulated. Similar to the endogenous skeletal muscle actin gene, the chimeric gene was expressed at a relatively high level in cardiac muscle of neonatal mice and at a significantly lower level in adult cardiac muscle. These results indicate that the injected DNA included sufficient *cis*-acting control elements for its tissue-specific and developmentally regulated expression in transgenic mice.

The introduction of cloned genes into mice via microinjection into fertilized eggs offers a unique opportunity to define regulatory mechanisms involved in the control of gene expression during ontogeny. It has recently been demonstrated that insertion of a number of tissue-specific genes into the mouse genome resulted in both tissue- and stage-specific expression of genes in transgenic mice, indicating that these genes responded to the developmental signals of the host (4, 6, 9, 11, 13, 15, 17, 18, 23, 24, 27, 28, 30, 33-35, 39).

The actins are a family of highly conserved proteins found in all eucaryotic cells. They play an important role in cell motility, cytoskeleton structure, and muscle contraction. Within vertebrates, at least six different actins have been identified: two striated forms (α skeletal and α cardiac), two smooth muscle forms (α and γ smooth actin), and two cytoplasmic forms (β and γ cytoplasmic actin) (36). Recent studies have shown that the skeletal muscle actin gene is expressed not only in skeletal muscle but also in the heart (12, 19, 21, 32). Furthermore, its expression in the heart is developmentally controlled; it is expressed at a significant level in embryonic and neonatal hearts, but the amount rapidly decreases thereafter. To identify and characterize *cis*-acting control elements involved in tissue-specific and developmentally regulated expression of the skeletal muscle actin gene, native genes or specifically modified genes were stably introduced into myogenic and nonmyogenic cells in culture (8, 20, 22). Melloul et al. (20) have transfected rat myogenic cells with a derivative of the rat skeletal muscle actin gene (in which about 2/3 of the skeletal muscle actin gene was spliced to the 3' end of a human embryonic globin gene). They have shown that in most myogenic clones transfected with this chimeric actin-globin gene, expression of the introduced gene was very similar to that of the endogenous skeletal muscle actin gene. Its expression was greatly increased during the transition from proliferating

mononucleated myoblasts to postmitotic multinucleated fibers, indicating that both genes responded to similar control mechanisms. However, the response of the chimeric gene in striated muscles (skeletal and cardiac) during development could not be ascertained in transfected myogenic cell cultures. It was therefore of interest to examine the mode of expression of the same DNA construct in transgenic mice.

In this paper I show that all six transgenic mice carrying the chimeric gene sequences without the vector DNA expressed the inserted gene in a tissue-specific manner, and in the five transgenic mouse strains that were analyzed it was also developmentally regulated. In contrast, none of the transgenic mice carrying the chimeric gene together with the vector DNA sequences expressed the introduced gene in striated muscles. Moreover, in one of these mice the chimeric gene was expressed in inappropriate tissues.

MATERIALS AND METHODS

Chimeric actin-globin gene. Construction of the chimeric gene has been described elsewhere (20). In this construct, the 1.3-kilobase (kb) *Bam*HI-*Eco*RI DNA fragment derived from the 3' end of the human embryonic globin gene (2) was ligated to the 3.0-kb *Eco*RI-*Bam*HI DNA fragment containing about 2/3 of the 5' region of the rat skeletal muscle actin gene (40). The resultant 4.3-kb DNA fragment was inserted into the *Eco*RI site of plasmid pBR322.

Microinjection into fertilized mouse eggs. Fertilized eggs were flushed from the oviducts of (C57BL/6J \times BALB/c) F_1 females mated with (C57BL/6J \times DBA) F_1 males. Manipulations of mice and eggs and the microinjection techniques were done as previously described (10, 30).

Preparation and hybridization of DNA. High-molecular-weight tail DNA was isolated by incubating 2-cm tail samples in 0.1 M EDTA-10 mM NaCl-10 mM Tris (pH 8.0)-1% sodium dodecyl sulfate-200 μ g of proteinase K per ml at 55°C for 12 h prior to phenol-chloroform extractions. DNA

samples were digested with restriction enzymes in the presence of 4 mM spermidine (4). DNA fragments were separated by electrophoresis on 0.8% agarose gels, transferred to nitrocellulose filters, and hybridized to ^{32}P -labeled probe as described (31). Filters were washed in $0.1\times$ SSC ($1\times$ SSC is 0.15 M NaCl plus 0.015 M sodium citrate)–0.2% sodium dodecyl sulfate at 74°C for 2 h.

Analysis of RNA. Total cellular RNA was prepared from mouse tissues by the lithium chloride-urea extraction method (1). RNA was hybridized in 15 μl of hybridization buffer with ^{32}P -end-labeled DNA fragments (3). The hybridization temperatures were 49°C for the *DdeI-DdeI* globin probe, 54°C for the *BamHI-EcoRI* DNA fragment, and 48°C for the *HinfI-SacI* DNA fragment. After S1 nuclease treatment, the products were analyzed on a 5% polyacrylamide-urea sequencing gel.

RESULTS

Production of mice carrying the chimeric actin-globin gene.

The structure of the chimeric actin-globin (pCV) gene that was used in the present studies is shown in Fig. 1a (see also reference 20). This 4.3-kb DNA construct, containing about 2/3 of the 5' region of the rat skeletal muscle actin gene, including 730 base pairs (bp) of the 5' flanking sequences, spliced to about 1/3 of the 3' region of the human embryonic globin gene plus 172 bp of its 3' flanking sequences, was inserted into the *EcoRI* site of plasmid pBR322. Fertilized mouse eggs obtained from a cross between (BALB/c \times C57BL/6J) F_1 females and (C57BL/6J \times DBA) F_1 males were microinjected with about 500 copies of either the entire plasmid DNA linearized with *EcoRI* or the isolated 4.3-kb DNA fragment containing the chimeric gene sequences without the vector DNA. Of 62 mice born, 11 contained DNA sequences homologous to the injected DNA. Five carried the entire plasmid (mice 1 to 5), and six carried the 4.3-kb DNA fragment (mice 6 to 11).

Figure 1b shows a Southern blot analysis of tail DNA of the 11 transgenic mice digested with the restriction enzymes *EcoRI* and *EcoRI-BamHI*. Under very stringent conditions (see Materials and Methods) the labeled probe hybridized to the inserted DNA sequences only and did not cross-hybridize with the endogenous actin genes. Hybridization of the labeled plasmid to the *EcoRI* digests revealed a series of hybridized DNA fragments. The 4.3-kb DNA fragment corresponded in size to both the plasmid pBR322 DNA and the chimeric actin-globin gene sequences. The additional hybridized fragments probably represent rearranged DNA sequences or junction fragments with host DNA. Hybridization to the *EcoRI-BamHI*-digested DNA generated the expected bands of 1.3-, 3.0-, and 4.0-kb DNA fragments. It was estimated that the different transgenic mice contained one or more copies of the injected DNA per cell. Mouse CV5 died soon after weaning.

Transmission of the chimeric actin-globin gene to progeny.

Each of the remaining 10 transgenic mice was mated with a normal mouse, and tail DNA from their progeny was analyzed by Southern blot hybridization for the presence of the injected DNA. The majority of these mice transmitted the inserted DNA sequences faithfully through the germ line to about 50% of the progeny. There was no evidence of major variations in the number or structure of the acquired DNA sequences (data not shown). In contrast, the analysis of inheritance of the chimeric gene in two mice (CV1 and CV4) revealed several abnormalities.

Figure 2a shows a Southern blot analysis of tail DNA from

22 first-generation positive progeny and the parent mouse DNA. Although statistically mouse CV1 transmitted the injected DNA sequences to about 50% of the progeny (Fig. 3), the hybridization pattern (Fig. 2a) clearly demonstrates that the integrated DNA sequences underwent major structural alterations. These alterations were of at least three types: deletion of a fraction of the integrated copies (mice 2, 3, 8, 21, and 22), amplification of the entire unit (mice 1, 10, and 16), and probably loss of recognition sites for the restriction enzyme *EcoRI* (mouse 4). When the filters were reprobbed with a single-copy gene (the myosin light chain-2

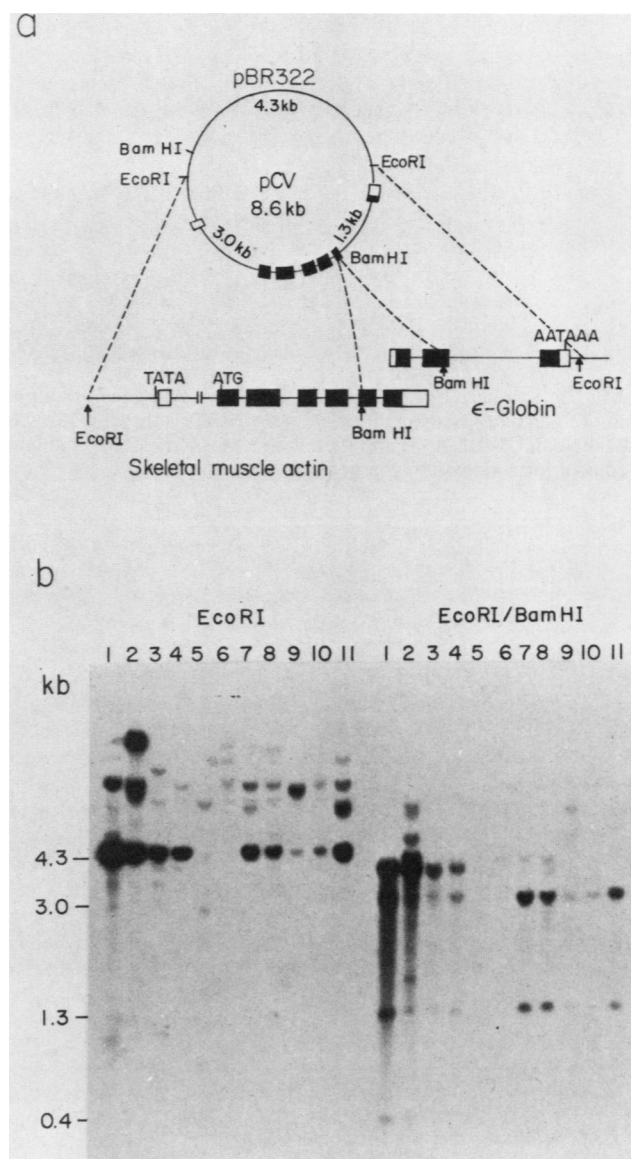

FIG. 1. Map of plasmid pCV and Southern blot analysis of DNA from 11 transgenic mice. (a) Chimeric rat actin-globin gene was constructed as described in reference 20. Solid bars; Coding regions; empty bars; 5' and 3' untranslated regions. (b) Tail DNA (10 μg) from transgenic mice CV1 to CV11 (lanes 1 to 11, respectively) was digested with *EcoRI* or *EcoRI* plus *BamHI*. The DNA fragments were blot hybridized with ^{32}P -labeled pCV DNA. The blot was washed at very high stringency ($0.1\times$ SSC at 74°C for 2 h). Molecular sizes are shown in kilobases.

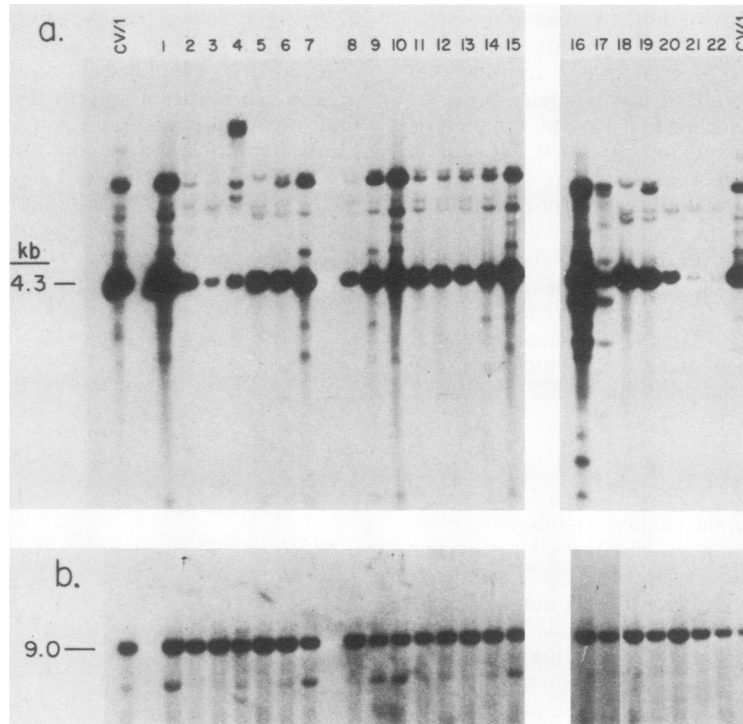
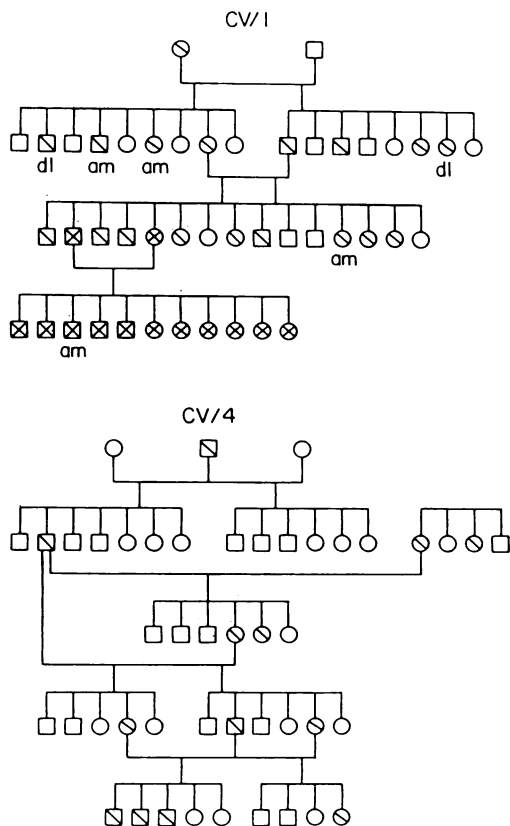

FIG. 2. Southern blot analysis of 22 positive first-generation progeny of mouse CV1. Tail DNA (10 μ g) from the founder CV1 mouse and from 22 positive first-generation progeny (lanes 1 through 22) was digested with *Eco*RI, and the fragments were blot hybridized first with 32 P-labeled pCV DNA (a) and then with a plasmid (p103) containing DNA sequences of the rat skeletal muscle myosin light chain-2 gene as a control for a single-copy gene (b).



gene), about the same intensity of hybridization was observed, indicating that about the same amounts of DNA were applied and that the digests were complete (Fig. 2b). These alterations were most pronounced in the first-generation progeny (8 of 22 progeny). Matings between heterozygous male and female offspring produced a more stable pattern of inheritance. However, even in this case and also in progeny derived from homozygous mice, occasional amplification or deletion could be observed (Fig. 3).

As shown in Fig. 3, mouse CV4 was probably a mosaic. Of its 56 offspring that were analysed, only 5 carried the introduced DNA sequences. Further evidence for mosaicism was obtained by Southern blot hybridization (data not shown). However, the most striking observation with this transgenic strain was the inability to produce homozygous offspring (Fig. 3). The absence of homozygotes was determined by Southern blot analysis of tail DNA from 45 progeny derived by mating heterozygous mice, with the skeletal muscle myosin light chain-2 gene used as an internal control for a single-copy gene. Only 19 of these mice carried the injected DNA, and none of them were homozygotes. The inability to produce homozygous mice was also associated with exceptionally small litter size (about 4 to 6 instead of the usual 10 to 12 pups per litter). Analysis at midgestation revealed only normal-looking fetuses. These results suggest

FIG. 3. Inheritance of actin-globin gene sequences in mice CV1 and CV4. Squares, males; circles, females; single diagonals, heterozygous; intersecting diagonals, homozygous. Mice marked am and dl contained amplified or deleted pCV DNA sequences, respectively.

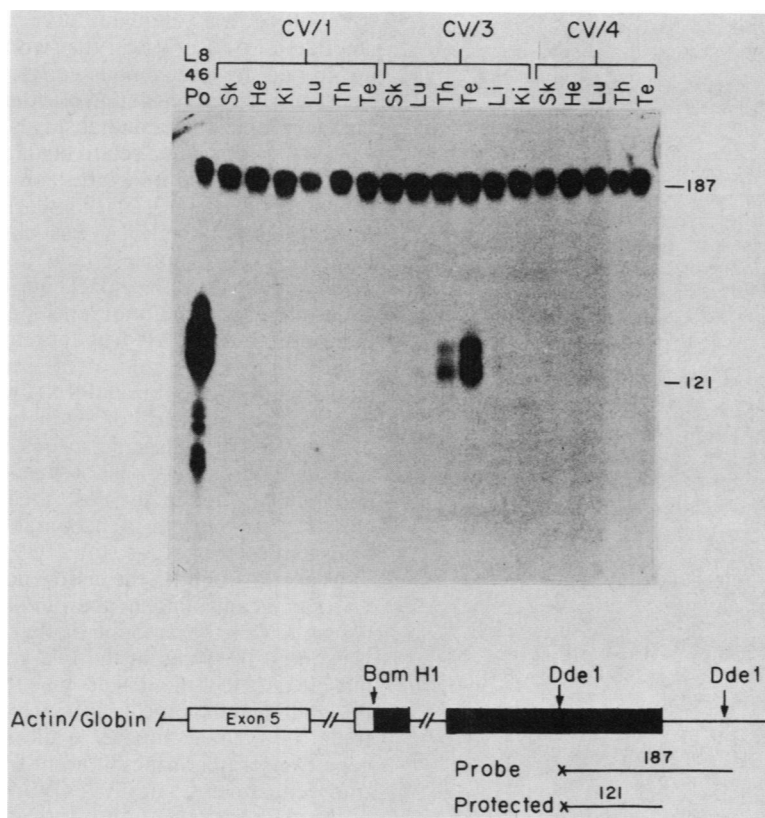

FIG. 4. S1 analysis of actin-globin gene transcripts in various tissues of transgenic mice CV1, CV3, and CV4. (Top) Total RNA (10 μ g) from the indicated tissues and total RNA from differentiated cultures of a transfected clone of the rat myogenic cell line L8-46 were hybridized with a 187-bp *DdeI* DNA fragment derived from the human ϵ -globin region of the construct. Sk, Skeletal muscle; He, heart; Ki, kidney; Lu, lung; Th, thymus; Te, testes. (Bottom) Solid box; Human globin coding sequences; open box; actin coding sequences. The 3' label is indicated by an asterisk, and the length of the probe and the protected fragment are also indicated in base pairs.

that in this transgenic strain homozygosity is lethal at some time before midgestation.

Expression of the chimeric gene in transgenic mice injected with the entire plasmid DNA. RNA was extracted from skeletal muscle and several other tissues of mice CV1 to CV4. The presence of the chimeric gene transcripts was determined by the S1 endonuclease mapping procedure, with the 187-bp *DdeI* DNA fragment derived from the human embryonic globin region of the construct (Fig. 4) used as probe. RNA from differentiated cultures of a stably transfected clone of the rat myogenic cell line L8 (L8-46) was used as a positive control. This RNA protected a DNA fragment of about 121 nucleotides. No detectable signal could be seen with skeletal muscle RNA of transgenic mice CV1, CV3, and CV4 (Fig. 4). Similar results were obtained with RNA from skeletal muscle from mouse CV2 (data not shown).

In transgenic mice CV1, CV2, and CV4, no transcripts could be detected in any other tissues examined. However, transcripts were detected in RNA prepared from the testes, thymus, and lung of mouse CV3. Such transcripts were most abundant in the testes and at a lower level in the thymus and lung. No transcripts were detected in the liver and kidney RNA of this transgenic mouse. The size of the protected fragments was similar to that generated by RNA from differentiated cultures of L8-46 cells, indicating that they terminate at the correct polyadenylation site of the globin gene sequences. The cap site of the actin-globin mRNA was

determined by using a 5'-end-labeled 92-bp *SacI-HinI* DNA fragment derived from the 5' region of the rat skeletal muscle actin gene (Fig. 5). RNA from the testes and thymus of transgenic mouse CV3 protected the diagnostic 54-nucleotide DNA fragment, indicating that these transcripts were initiated at the correct cap site of the rat gene.

Expression of the inserted gene in transgenic mice carrying only the chimeric gene sequences. It was recently demonstrated that the prerequisite for achieving appropriate tissue-specific expression of globin genes in transgenic mice was the removal of the plasmid vector sequences prior to microinjection (6, 35). To determine whether inappropriate expression of the chimeric gene was due to the presence of procaryotic DNA sequences, six additional transgenic strains carrying only the chimeric gene sequences were analyzed. RNA was isolated from skeletal muscle, cardiac muscle, spleen, kidney, and lung. The presence of the chimeric gene transcripts in these RNA preparations was determined by the S1 endonuclease technique described above. In each of these mice, chimeric gene transcripts were detected in skeletal muscle and in cardiac muscle, but not in RNA prepared from the other tissues tested (Fig. 6a). The level of expression in these mice varied, but was comparable to that found in differentiated cultures of the stably transfected clone of the rat myogenic cell line L8 (CV46P). Melloul et al. (20) have shown that in this clone the level of expression of the transfected gene was about twice that of the endogenous skeletal muscle actin gene. Except for

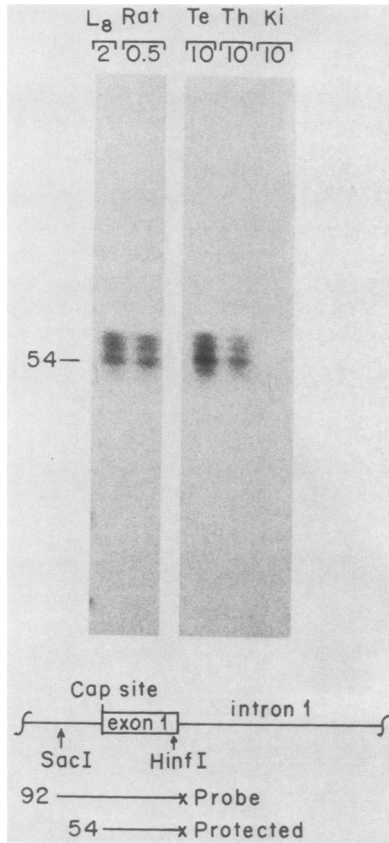

FIG. 5. Initiation of the chimeric actin-globin gene transcripts in inappropriate tissues of mouse CV3 is at the correct cap site of the rat gene. (Top) Total RNA from rat skeletal muscle (0.5 μ g) or differentiated cultures of the rat myogenic cell line L8 (2.0 μ g) and 10 μ g of RNA from the testes (Te), thymus (Th), and kidney (Ki) of transgenic mouse CV3 were hybridized with 5'-end-labeled *HinfI*-*SacI* DNA fragment (see bottom). After S1 digestion, the resistant hybrids were sized on 5% acrylamide-7 M urea gels. (Bottom) Open box; 5' untranslated exon of the rat skeletal muscle actin gene. The 5' label is indicated by an asterisk, and the length of the probe and the protected fragment is shown in nucleotides.

mouse CV9, expression was significantly higher in skeletal muscle than in cardiac muscle. The relative amounts of the endogenous skeletal muscle actin gene transcripts in skeletal muscle and in cardiac muscle were then determined. A DNA fragment 465 nucleotides long, extending from the *Bam*HI site in exon 6 of the rat skeletal muscle actin gene (Fig. 1a) to the *Eco*RI site of Act15.2 (40) was isolated and endlabeled with the Klenow fragment of DNA polymerase. RNA prepared from skeletal muscle and from cardiac muscle protected a predominant DNA fragment of 162 nucleotides (Fig. 6b) (the protected fragment extends from the *Bam*HI site to the end of the sixth exon of the rat skeletal muscle actin gene [19, 40]). The protection of smaller DNA fragments probably reflects some mismatching between the rat and mouse skeletal muscle actin genes. The amount of skeletal muscle actin mRNA sequences in RNA prepared from adult hearts was about 5 to 10% of that in the leg muscle RNA. The amount of chimeric gene transcripts in RNA prepared from adult hearts varied from 30 to about 100% of that found in leg muscle RNA. These results indicate that removal of the procaryotic vector sequences led to tissue-specific expression of the chimeric gene in all six transgenic mice. How-

ever, there was a quantitative difference in the relative amounts of transcripts in the two tissues between the introduced and the endogenous genes.

Developmental regulation of chimeric gene expression. During embryonic and neonatal stages, the skeletal muscle actin gene is expressed at a relatively high level in cardiac muscle, while at adulthood its expression drops to about 5% of that in the leg muscle (19, 21). Similarly, a significant amount of the cardiac actin mRNA was observed in embryonic and neonatal skeletal muscle, and it decreased rapidly during development (19, 21, 26). Thus, the two sarcomeric actin genes are expressed in a developmentally regulated manner in striated muscles. It was therefore of interest to examine whether the expression of the introduced gene followed a similar pattern. To this end RNA was extracted from cardiac and skeletal muscles of neonatal and 2- or 4-month-old progeny of five transgenic strains. The level of transcripts of the chimeric and endogenous genes was assayed by the S1 endonuclease technique described above.

In cardiac muscle of neonatal mice, in four of the five transgenic strains (CV6, CV7, CV9, and CV11), the amount of transcripts of both the endogenous and the chimeric genes was significantly higher than in skeletal muscle (Fig. 7). In mouse CV10 the amount of the chimeric gene transcripts was about the same in the two striated muscles. In cardiac muscle of 2- to 4-month-old mice the amount of transcripts of the endogenous gene was approximately 2 to 10% of that found in skeletal muscle, while it varied for the chimeric gene transcripts in the different transgenic strains. Thus, in transgenic mice CV6, CV7, CV9, CV10, and CV11 the level of the chimeric gene transcripts in cardiac muscle was 30, 5, 80, 30, and 40%, respectively, of that present in skeletal muscle (Fig. 7). Despite these quantitative differences, the pattern appears to be consistent and suggests that the chimeric actin-globin gene responded to developmental regulation in striated muscles.

DISCUSSION

The results presented in this communication demonstrate that in the six transgenic mice carrying the chimeric gene sequences without the vector DNA, expression of the introduced gene was specific to striated muscles and was undetectable in other tissues that were tested. Except for mouse CV9, the expression in skeletal muscle of adult mice was significantly higher than in cardiac muscle. More importantly, similar to the endogenous gene, the introduced gene underwent a transition in the relative tissue specificity during development. In neonatal mice, four of the five strains analyzed showed higher expression of the chimeric gene in cardiac muscle than in leg muscle, while in adult mice it was higher in skeletal muscle. However, the magnitude of the developmental transition for the endogenous skeletal muscle actin gene was about fivefold greater than that for the inserted gene. This is mainly the result of the persistence of a relatively high level of expression of the chimeric gene in adult cardiac muscles. Whether this quantitative difference between the chimeric and the endogenous gene transcripts in the two striated muscles is due to chromosomal position effect remains to be determined. Alternatively, this difference could be due to the substitution of the authentic rat skeletal muscle actin 3' region by the human globin 3' end or because the 5' flanking region included in the inserted rat DNA is too short and does not contain all control elements required for tissue-specific and developmentally regulated expression.

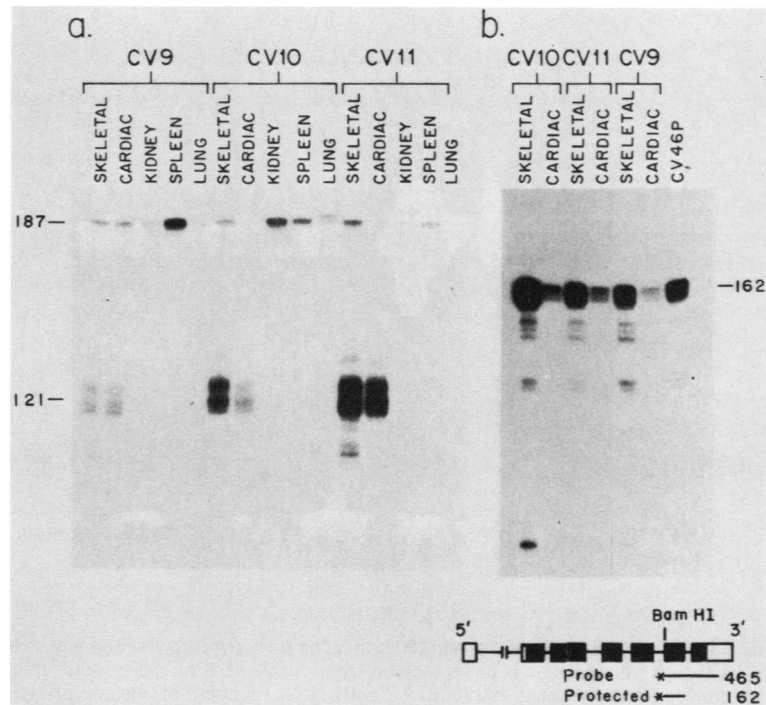

FIG. 6. S1 analysis of actin-globin and endogenous skeletal muscle actin gene transcripts in various tissues of transgenic mice. Total RNA (5 μ g) from the indicated tissues of transgenic mice CV9, CV10, and CV11 and total RNA (5 μ g) from differentiated cultures of a transfected clone of the rat myogenic cell line CV-46P were hybridized with (a) a 187-bp *DdeI* DNA fragment derived from the human globin region of the construct (see map in Fig. 4) or (b) a 465-bp *BamHI-EcoRI* DNA fragment of plasmid pAct15.2 (40). A schematic presentation of the rat skeletal muscle actin gene, the end-labeled probe, and the protected fragment is shown. Open boxes, Untranslated regions; solid boxes, coding sequences. Fragment sizes are indicated in nucleotides. Asterisk, Position of 3' label.

Although the results obtained with the endogenous skeletal muscle actin gene are in general agreement with those reported previously (19, 21), there are numerical differences in the relative levels of transcripts of the skeletal muscle actin gene in cardiac and in skeletal muscles. In 2- or 4-month-old mice the concentration of skeletal muscle actin mRNA in cardiac muscle RNA was approximately 2 to 10% of that in leg muscle RNA. In 2-day-old mice the concentration of the skeletal muscle actin mRNA in cardiac muscle was up to four times higher than in skeletal muscle. The reason for the discrepancy is not clear. It may be due to different assay techniques (Northern or spot hybridization versus S1 mapping) or it may reflect differences in the biological systems (rats versus mice).

In transgenic mice carrying the chimeric gene together with the vector DNA sequences, three types of aberrations were observed: local instability at the site of integration, possible insertional mutagenesis, and inappropriate expression. Although similar abnormalities were not found in mice carrying the chimeric gene sequences alone, it is not yet clear whether they are a consequence of the presence of the prokaryotic vector sequences. The apparent instability in the number of the inserted sequences in the offspring of transgenic mouse CV1 could be due to either passive or active events. Integration could occur at a chromosomal site which normally undergoes expansion and contraction as a result of homologous recombinations of repeated DNA sequences that flank the integrated gene. Alternatively, insertion of foreign genetic information could destabilize the local chromosomal domain, leading to excessive activation or inactivation of the host cell replicons at the site of integration. It is not yet understood why this phenomenon is

more pronounced in the heterozygous progeny of the first generation and less so in the homozygous state.

Integration of the chimeric gene in mouse CV4 probably led to insertional mutagenesis. This mutagenesis was revealed by the significantly low litter size in most of the matings between heterozygous mice and by the inability to produce a homozygous strain. It is of interest that the average litter size was low even for matings between heterozygous males and wild-type females (Fig. 3). A similar phenomenon was reported previously by Wagner et al. (37). Insertional mutagenesis has been reported for both viral and cellular genes inserted into mouse germ lines (7, 14, 25, 29, 37, 38). In only one of these cases was the site of integration identified at the molecular level. Although it would be extremely important if insertional mutagenesis of this kind made possible the identification of genes that are involved in developmental decisions, it should be clear that interfering with the mode of expression of any gene (control genes as well as housekeeping genes) during early stages of embryogenesis could be deleterious to normal development.

In the four transgenic mice carrying this chimeric gene together with the vector DNA sequences, no transcripts could be detected in skeletal muscle RNA. Surprisingly, in one transgenic strain the chimeric gene mRNA was detected in several nonmyogenic tissues. Inappropriate expression in transgenic mice has been found previously following microinjection of a globin gene with prokaryotic vector sequences (16). This lack of expression in skeletal muscle is of special interest, since the same DNA construct was expressed in an apparently stage-specific manner in most stably transfected myogenic cells (20). This may imply that there are different requirements for expression in transfected

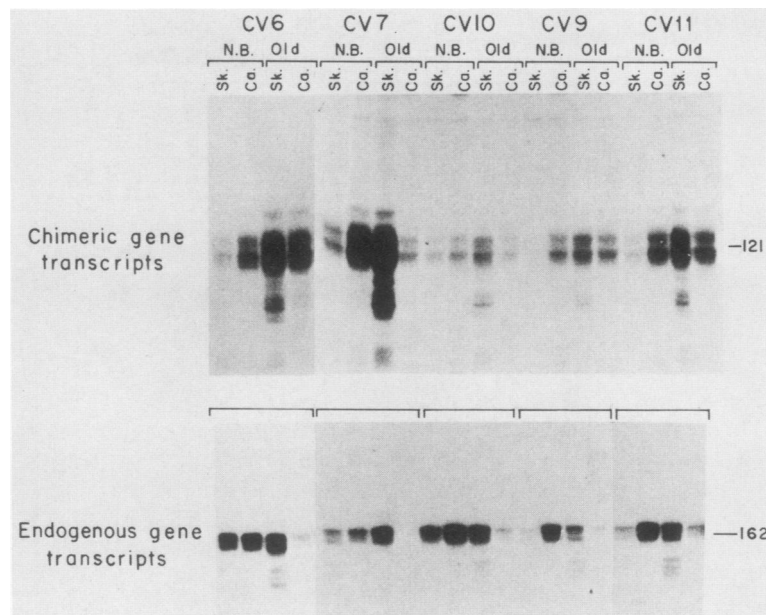

FIG. 7. S1 analysis of actin-globin and endogenous skeletal muscle actin gene transcripts in striated muscles of neonatal (N.B.) and 2- and 4-month-old (Old) mice. Total RNA (5 μ g) from cardiac (Ca) or skeletal (Sk) muscle of neonatal or adult mice was hybridized (a) with the human globin DNA probe (see map in Fig. 4) and (b) with the *Bam*HI-*Eco*RI DNA fragment of plasmid pAct.15.2 (see map in Fig. 6). Adult RNA preparations were obtained from 2-month-old mouse CV6 and 4-month-old mice CV7, CV9, CV10, and CV11. The amounts of neonatal RNA samples were not corrected for the percentage of transgenic animals in each litter, which was determined by Southern blot analysis of liver DNA. Thus, for the different transgenic strains these values ranged from 20 to 80% of the offspring. Fragment sizes are shown in nucleotides.

somatic cells and for developmentally regulated expression in transgenic mice. Recently, I showed that the rat skeletal muscle myosin light chain-2 gene was expressed specifically in skeletal muscle of transgenic mice but not in other tissues regardless of the presence of the vector sequences (30). Moreover, the expression of the rat myosin light chain-2 gene was not only tissue specific but also stage specific (D. Yaffe, O. Saxel, and M. Shani, manuscript in preparation). These results suggest that there is a difference in the control of expression of the two skeletal muscle genes, the control of the myosin light chain-2 gene being more autonomous and less influenced by the presence of procaryotic DNA sequences or by the chromosomal site of integration. The possible inhibitory effect of procaryotic vector DNA sequences on the expression of several genes in transgenic mice has been discussed previously (6, 35). It is still not clear why this type of inhibition affects some genes (α -fetoprotein, skeletal muscle actin, globin) while having no apparent influence on others (e.g., immunoglobulin genes). Perhaps it reflects the strength of the control elements within the injected DNA.

The apparent tissue-specific and developmental regulation of the chimeric gene in transgenic mice indicates that the inserted gene segment includes *cis*-acting sequences sufficient to specify the correct expression of this gene at the appropriate tissues and to respond to developmental switches that are involved in isoform transitions. It should now be possible to extend these studies and insert specifically modified actin genes to more precisely localize and characterize the sequences responsible for both tissue and developmental regulation of this gene.

ACKNOWLEDGMENTS

I thank David Yaffe and Uri Nudel for fruitful collaboration and Olla Yoffe and Sara Neuman for technical assistance.

This work was supported by the U.S. Muscular Dystrophy Association, Inc., and by the Israeli Academy of Sciences and Humanities.

LITERATURE CITED

1. Auffray, C., and F. Rougeon. 1980. Purification of immunoglobulin heavy chain mRNA from total myeloma tumor RNA. *Eur. J. Biochem.* **107**:303-313.
2. Baralle, F. E., C. C. Shoulders, and N. J. Proudfoot. 1980. The primary structure of the human ϵ -globin gene. *Cell* **21**:621-626.
3. Berk, A. J., and P. A. Sharp. 1977. Sizing and mapping of early adenovirus mRNA by gel electrophoresis of S1 endonuclease-digested hybrids. *Cell* **12**:721-732.
4. Bouche, J. P. 1981. The effect of spermidins on endonuclease inhibition by agarose contaminants. *Anal. Biochem.* **115**:42-46.
5. Brinster, R. L., K. A. Ritchie, R. E. Hammer, R. L. O'Brien, B. Arp, and U. Storb. 1983. Expression of a microinjected immunoglobulin gene in the spleen of transgenic mice. *Nature (London)* **306**:332-336.
6. Chada, K., J. Magram, K. Raphael, G. Radice, E. Lacy, and F. Costantini. 1985. Specific expression of a foreign β -globin gene in erythroid cells of transgenic mice. *Nature (London)* **314**:377-380.
7. Copeland, N. G., N. A. Jenkins, and B. K. Lee. 1983. Association of the lethal yellow (A^y) coat color mutation with an ecotropic MuLV genome. *Proc. Natl. Acad. Sci. USA* **80**:247-249.
8. Eiler-Tuyn, A., J. D. Eldridge, and B. M. Paterson. 1984. Expression and regulation of chicken actin genes introduced into mouse myogenic and nonmyogenic cells. *Proc. Natl. Acad. Sci. USA* **81**:2980-2984.
9. Frels, W. I., J. A. Bluestone, R. J. Hodes, M. R. Capecchi, and D. S. Singer. 1985. Expression of a microinjected porcine class I major histocompatibility complex gene in transgenic mice. *Science* **228**:577-580.
10. Gordon, J. E., and F. H. Ruddle. 1983. Gene transfer into mouse embryos: production of transgenic mice by pronuclear injection. *Methods Enzymol.* **101**:411-433.

11. Grosschedl, R., D. Weaver, D. Baltimore, and F. Costantini. 1984. Introduction of a μ immunoglobulin gene into the mouse germ line: specific expression in lymphoid cells and synthesis of functional antibody. *Cell* 38:647-658.
12. Gunning, P., P. Ponte, H. Blau, and L. Kedes. 1983. α skeletal and α cardiac actin genes are coexpressed in adult human skeletal muscle and heart. *Mol. Cell. Biol.* 3:1985-1995.
13. Hanahan, D. 1985. Heritable formation of pancreatic β -cell tumors in transgenic mice expressing recombinant insulin/SV40 oncogenes. *Nature (London)* 315:115-122.
14. Jenkins, N. A., N. G. Copeland, B. A. Taylor, and B. K. Lee. 1981. Dilute (d) coat colour mutation of DBA/2J mice is associated with the site of integration of an ecotropic MuLV genome. *Nature (London)* 293:370-374.
15. Krumlauf, R., R. E. Hammer, S. M. Tilghman, and R. L. Brinster. 1985. Developmental regulation of α -fetoprotein genes in transgenic mice. *Mol. Cell. Biol.* 5:1639-1648.
16. Lacy, E., S. Roberts, E. P. Evans, M. D. Burtenshaw, and F. D. Costantini. 1983. A foreign β globin gene in transgenic mice: integration at abnormal chromosomal positions and expression in inappropriate tissues. *Cell* 34:343-358.
17. Le-Meur, M., P. Gerlinger, C. Benoist, and D. Mathis. 1985. Engineering the murine immune response: correct expression of an E α gene in transgenic mice. *Nature (London)* 316:38-42.
18. Magram, J., K. Chada, and F. Costantini. 1985. Developmental regulation of a cloned adult β -globin gene in transgenic mice. *Nature (London)* 315:338-340.
19. Mayer, Y., H. Czosnek, P. E. Zeelon, D. Yaffe, and U. Nudel. 1984. Expression of the gene coding for the skeletal muscle and cardiac actins in the heart. *Nucleic Acids Res.* 12:1087-1100.
20. Melloul, D., B. Aloni, J. Calvo, D. Yaffe, and U. Nudel. 1984. Developmentally regulated expression of chimeric genes containing muscle actin DNA sequences in transfected myogenic cells. *EMBO J.* 3:983-990.
21. Minty, A. J., S. Alonso, M. Caravatti, and M. E. Buckingham. 1982. A fetal skeletal muscle actin mRNA in the mouse and its identity with cardiac actin mRNA. *Cell* 30:186-192.
22. Nudel, U., D. Greenberg, D. P. Ordahl, O. Sexel, S. Neuman, and D. Yaffe. 1985. Developmentally regulated expression of a chicken muscle-specific gene in stably transfected rat myogenic cells. *Proc. Natl. Acad. Sci. USA* 82:3106-3109.
23. Ornitz, D. M., R. D. Palmiter, R. E. Hammer, R. L. Brinster, G. H. Swift, and R. J. MacDonald. 1984. Specific expression of an elastase-human growth hormone fusion gene in pancreatic acinar cells of transgenic mice. *Nature (London)* 313:600-602.
24. Overbeek, P. A., A. B. Chepelinsky, J. S. Khillan, J. Piatigorsky, and H. Westphal. 1985. Lens-specific expression and developmental regulation of the bacterial chloramphenicol acetyltransferase gene driven by the murine α A-crystallin promoter in transgenic mice. *Proc. Natl. Acad. Sci. USA* 82:7815-7819.
25. Palmiter, R. D., T. M. Wilkie, H. Y. Chen, and R. L. Brinster. 1984. Transmission distortion and mosaicism in an unusual transgenic mouse pedigree. *Cell* 36:869-877.
26. Paterson, B. M., and J. D. Eldridge. 1984. α -Cardiac actin is the major sarcomeric isoform expressed in embryonic avian skeletal muscle. *Science* 224:1436-1438.
27. Pinkert, C. A., G. Widera, C. Cowing, E. Heber-Katz, R. D. Palmiter, R. A. Flavell, and R. L. Brinster. 1985. Tissue specific, inducible and functional expression of the E α d MHC class II gene in transgenic mice. *EMBO J.* 4:2225-2230.
28. Rusconi, S., and G. Köhler. 1985. Transmission and expression of a specific pair of rearranged immunoglobulin μ and κ genes in transgenic mouse line. *Nature (London)* 314:330-334.
29. Schnieke, A., K. Harbers, and R. Jaenisch. 1983. Embryonic lethal mutation in mice induced by retrovirus insertion in the α 1(1) collagen gene. *Nature (London)* 304:315-320.
30. Shani, M. 1985. Tissue-specific expression of rat myosin light chain 2 gene in transgenic mice. *Nature (London)* 314:283-286.
31. Shani, M., S. Admon, and D. Yaffe. 1984. The methylation state of 2 muscle-specific genes: restriction enzyme analysis did not detect a correlation with expression. *Nucleic Acids Res.* 12:7225-7234.
32. Shani, M., U. Nudel, D. Zevin-Sonkin, R. Zakut, D. Givol, D. Katcoff, Y. Carmon, J. Reiter, A. M. Frishauf, and D. Yaffe. 1981. Skeletal muscle actin mRNA: characterization of the 3' untranslated region. *Nucleic Acids Res.* 9:579-589.
33. Storb, U., R. L. O'Brien, M. D. L. McMullen, K. A. Gollahan, and R. L. Brinster. 1984. High expression of cloned immunoglobulin κ gene in transgenic mice is restricted to B lymphocytes. *Nature (London)* 310:238-241.
34. Swift, C. H., R. E. Hammer, R. J. MacDonald, and R. L. Brinster. 1984. Tissue-specific expression of the rat pancreatic elastase I gene in transgenic mice. *Cell* 38:639-646.
35. Townes, T. M., J. B. Lingrel, H. Y. Chen, R. L. Brinster, and R. D. Palmiter. 1985. Erythroid-specific expression of human β -globin genes in transgenic mice. *EMBO J.* 4:1715-1723.
36. Vanderkerckhove, J., and K. Weber. 1979. At least six different actins are expressed in a higher mammal: an analysis based on the amino acid sequence of the amino terminal tryptic peptide. *J. Mol. Biol.* 126:783-802.
37. Wagner, E. F., L. Covarrubias, T. A. Stewart, and B. Mintz. 1983. Prenatal lethality in mice homozygous for human growth hormone gene sequences integrated in the germ line. *Cell* 35:647-655.
38. Woychik, R. P., T. A. Stewart, L. G. Davis, P. D'Eustachio, and P. Leder. 1985. An inherited limb deformity created by insertional mutagenesis in a transgenic mouse. *Nature (London)* 318:36-40.
39. Yamamura, K., H. Kikutani, V. Folsom, L. K. Clayton, M. Kimoto, S. Akira, S. Kashiwamura, S. Tonegawa, and T. Kishimoto. 1985. Functional expression of a microinjected E α d gene in C57BL/6 transgenic mice. *Nature (London)* 316:67-69.
40. Zakut, R., M. Shani, D. Givol, S. Neuman, D. Yaffe, and U. Nudel. 1980. The nucleotide sequence of the rat skeletal muscle actin gene. *Nature (London)* 298:857-859.