

## Sequence-Dependent DNA Replication in Preimplantation Mouse Embryos

DANA O. WIRAK,<sup>1</sup> LORRAINE E. CHALIFOUR,<sup>1†</sup> PAUL M. WASSARMAN,<sup>1‡</sup> WILLIAM J. MULLER,<sup>2</sup> JOHN A. HASSELL,<sup>2</sup> AND MELVIN L. DEPAMPHILIS<sup>1\*</sup>

*Department of Biological Chemistry, Harvard Medical School, Boston, Massachusetts 02115<sup>1</sup>; and Department of Microbiology and Immunology, McGill University, Montreal, Quebec H3A2B4 Canada<sup>2</sup>*

Received 20 May 1985/Accepted 1 August 1985

**Circular, double-stranded DNA molecules were injected into nuclei of mouse oocytes and one- or two-cell embryos to determine whether specific sequences were required to replicate DNA during mouse development. Although all of the injected DNAs were stable, replication of plasmid pML-1 DNA was not detected unless it contained either polyomavirus (PyV) or simian virus 40 (SV40) DNA sequences. Replication occurred in embryos, but not in oocytes. PyV DNA, either alone or recombined with pML-1, underwent multiple rounds of replication to produce superhelical and relaxed circular monomers after injection into one- or two-cell embryos. SV40 DNA also replicated, but only 3% as well as PyV DNA. Coinjection of PyV DNA with either pML-1 or SV40 had no effect on the replicating properties of the three DNAs. These results are consistent with a requirement for specific *cis*-acting sequences to replicate DNA in mammalian embryos, in contrast to sequence-independent replication of DNA injected into *Xenopus* eggs. Furthermore, PyV DNA replication in mouse embryos required PyV large T-antigen and either the  $\alpha$ - $\beta$ -core or  $\beta$ -core configuration of the PyV origin of replication. Although the  $\alpha$ -core configuration replicated in differentiated mouse cells, it failed to replicate in mouse embryos, demonstrating cell-specific activation of an origin of replication. Replication or expression of PyV DNA interfered with normal embryonic development. These results reveal that mouse embryos are permissive for PyV DNA replication, in contrast to the absence of PyV DNA replication and gene expression in mouse embryonal carcinoma cells.**

Although *ori* sequences have not yet been demonstrated as functional elements of eucaryotic chromosomes, they are implicated strongly by the temporal order of gene replication (11, 36); the selective amplification of specific genes (53, 65, 74); the existence of autonomously replicating sequences (26, 76); and the fact that all bacterial, viral, plasmid, and organelle genomes require one or more unique *cis*-acting sequences that act as origins of replication (*ori*) and interact with specific gene products. However, some observations suggest that DNA replication during the early stages of embryonic development may not require sequence-specific origins of replication to carry out DNA replication.

Analysis of DNA replication in *Drosophila melanogaster* (6, 56, 85) has revealed that the average distance between chromosome replication bubbles in preblastomere embryos is at least five times smaller than that in differentiated cells, suggesting that embryos initiate replication at many more sequences than do differentiated cells of the same species. Furthermore, injection of DNA into *Xenopus* eggs revealed that semiconservative DNA replication can occur under the apparent control of the cell division cycle but with no apparent requirement for specific DNA sequences (34, 57, 58). All of the DNA molecules examined, including simian virus 40 (SV40) and polyomavirus (PyV) DNA which normally replicate only in differentiated cells of a specific mammalian host, replicated to the same extent in amphibian eggs. Some indication of sequence-specific replication has

been reported (13, 39), but the interpretation of these results has been questioned (58).

To determine whether the requirements for DNA replication during early stages of mammalian development differed from those of differentiated mammalian cells, we injected into the nuclei of mouse embryos a variety of DNA sequences whose replication in mouse differentiated cells is well characterized. PyV and SV40 normally replicate their DNA in nuclei of mammalian cells as a circular chromosome containing 5.2 kilobases of double-stranded DNA. With the exception of initiation, all steps in viral DNA replication and chromosome assembly are carried out exclusively by the host cell when it enters S-phase (20; M. L. DePamphilis and M. K. Bradley, in N. Salzman (ed.), *Replication of Simian Virus 40 and Polyoma Virus Chromosomes*, in press). Initiation of viral DNA replication requires binding of viral-encoded large T-antigen protein at or near the viral *ori* sequence in the presence of one or more permissive cell factors. For PyV, these permissive cell factors are found in mouse differentiated cells. However, mouse differentiated cells are nonpermissive for replication of SV40, another member of the papovavirus family, whose normal host is African green monkey cells. SV40 expresses its early genes (large and small T-antigens) in mouse differentiated cells and induces the cell to enter S-phase, but it fails to replicate its own DNA, and expresses its late genes (capsid proteins) only at a low rate.

Although PyV replicates in a variety of differentiated mouse cells (25), neither mouse embryos (44) nor mouse embryonal carcinoma (EC) cells have been reported to support PyV DNA transcription (19, 31, 71) or replication (18, 30). EC cells share many properties found in multipotent cells of 7- to 8-day-old mouse embryos (54). Since PyV will

\* Corresponding author.

† Present address: Biotechnology Research Institute, Montreal, Canada.

‡ Present address: Department of Cell Biology, Roche Institute of Molecular Biology, Nutley, NJ 07110.

replicate in EC cells after they have differentiated in vitro (7, 77), permissive cell factors for PyV may be expressed only at specific stages in development.

The PyV *cis*-acting origin of replication includes an enhancer element (12, 23, 62, 79) in addition to a core sequence, so called because of its similarity among papovavirus origins of replication (DePamphilis and Bradley, in press). SV40 *ori* is analogous to the PyV core sequence, but the 72-base-pair enhancer sequences can be eliminated with little or no reduction in replication activity (see Fig. 6). Since mutations in the PyV enhancer region allow PyV T-antigen-dependent DNA replication in mouse EC cells (see Fig. 6), enhancer elements may be one factor in determining viral host-range specificity.

Based on published studies of PyV and SV40 DNA replication in differentiated and embryonic mammalian cells, one would not expect viral DNA to replicate in mouse embryos, unless, like amphibian embryos, they are promiscuous for DNA replication. We found, however, that mouse embryos at the earliest stage in development (one-cell) replicated DNA only when they contained *ori* sequences known to function in mammalian cells. Furthermore, embryos exhibited some permissive cell characteristics of mouse fibroblasts, but failed to utilize one configuration of the PyV *ori* sequence that was used in differentiated mouse cells.

## MATERIALS AND METHODS

**Bacteria and plasmids.** *Escherichia coli* HB101 (*recA13 dam<sup>+</sup>*) and 011(*thyA*) were obtained from Charles Richardson (Harvard Medical School, Boston). PyV A3 (69) cloned into pBR322 (pBRPy314d) was provided by Bill Folk (University of Texas, Austin). Plasmids pML-1 and pJYM were obtained from Michael Botchan (University of California, Berkeley). pML-1 was a 2,969-base-pair molecule derived from pBR322 by deletion of sequences that reduced the ability of SV40 cloned DNA to replicate in cultured cells. pJYM consisted of SV40 DNA, cleaved at its unique *Bam*HI site in the VP-1 gene, and cloned into the unique *Bam*HI site of pML-1 (49). Plasmids pdPB1a (pB1a), pdPBR2 ( $\alpha$ - $\beta$ -core<sup>+</sup>), pdPd1-8 ( $\alpha$ - $\beta$ ), pdPB503Bg(H) ( $\alpha$ - $\beta$ -core), pdPB503dl300 ( $\alpha$ -core), and pdPP<sub>1</sub>(B)Bg(H) ( $\beta$ -core) have been described by Muller et al. (62) (see Fig. 6). They consisted of PyV A1 sequences cloned into pML-2 which is identical to plasmid pML-1. The designations in parentheses were assigned for simplicity. pB1a consisted of PyV A1 DNA, cleaved at its unique *Bam*HI site in the coat protein genes, and cloned into the unique *Bam*HI site of pML-2.

**Cells and viruses.** Mouse 3T6 cells were obtained from Howard Green (Harvard Medical School). MOP-8 cells have been described previously (62). SV40 *wt800* (35) was propagated in CV-1 monkey cells as described by Anderson et al. (2). PyV A3 was prepared by transfecting 3T6 cells with PyV sequences isolated from pBRPy314d (55), and a cell lysate was used to infect 3T6 cells to produce a virus stock with a higher titer. Restriction enzyme analysis of PyV form I DNA from the final lysate confirmed that at least 99% was wild-type virus.

**Preparation of viral and plasmid DNA.** SV40 DNA was isolated from CV-1 monkey cells 36 h after infection by the procedures of Hirt (40) and Tapper and DePamphilis (78). PyV DNA was harvested 26 h after infection of 3T6 cells and purified as described for SV40 DNA. Plasmid DNAs were transformed into *E. coli* HB101, harvested by the sodium

dodecyl sulfate (SDS) lysis procedure of Maniatis et al. (52) and purified as described for viral DNA.

DNA used for microinjection was stored as an ethanol precipitate at  $-20^{\circ}\text{C}$ . Before injection, the precipitate was washed once with 70% ethanol at room temperature. Pellets were dried under vacuum and suspended in 50 mM potassium phosphate-14 mM sodium phosphate (pH 7.2) (33) to give 0.1 to 15 mg of DNA per ml. All containers and pipettes that came in contact with the DNA samples were first washed in deionized water that had been passed through 0.2- $\mu\text{m}$  Millipore filters to remove particulate matter, and washed containers were used to filter the 70% ethanol and the DNA injection buffer. Immediately before injection, the DNA samples were centrifuged at  $27,000 \times g$  for 1 h ( $4^{\circ}\text{C}$ ) to remove particles.

**Isolation and culture of mouse oocytes and embryos. (i) Oocytes.** Growing oocytes were dissected manually out of follicles of ovaries from female CD-1 mice (Charles River Breeding Laboratories, Inc., Wilmington, Mass.) that were 14 to 19 days old (82). The oocytes were cultured under Parafilm oil in standard egg culture medium supplemented with 100  $\mu\text{g}$  of dibutyl cyclic AMP per ml (75). The cultures were incubated in 5%  $\text{CO}_2$  at  $37^{\circ}\text{C}$ . Approximately 100 oocytes were recovered per mouse.

**(ii) Embryos.** CD-1 female mice 5 to 6 weeks old were induced to superovulate and were mated with CD-1 male mice (9). One-cell embryos were isolated from females 18 to 20 h after administration of human chorionic gonadotropin, and two-cell embryos were isolated 40 to 42 h after administration of human chorionic gonadotropin (8). Embryos were cultured to the four-cell stage under Parafilm oil in 50  $\mu\text{l}$  of the medium described by Whitten and Biggers (83) supplemented with 4  $\mu\text{M}$  EDTA (1). The medium was then supplemented with 10% calf serum that had been heat-inactivated at  $60^{\circ}\text{C}$  for 30 min to destroy proteases and complement. Cultures were incubated in 5%  $\text{CO}_2$  at  $37^{\circ}\text{C}$ . Approximately 20 to 50 embryos were recovered per mouse.

**Injection of DNA into mouse oocytes and embryos.** DNA was injected into the germinal vesicle of oocytes 1 to 4 h after isolation and into the male pronucleus of one-cell embryos or into one of the nuclei of two-cell embryos about 24 or 45 h, respectively, after the administration of human chorionic gonadotropin. The oocytes and embryos were then cultured in vitro as described above. Micropipettes were constructed from borosilicate glass capillary tubing (1-mm outside diameter, 0.5-mm inside diameter; Glass Co. of America). The tubing was flushed with acetone and then dried at  $60^{\circ}\text{C}$ . Pipettes were pulled in a pipette puller (PN-3; Narishige) and stored in dust-free containers. Cell holders were constructed with a microforge (DeFonbrune) and had a fire-polished blunt end (40- $\mu\text{m}$  outside diameter, 10- $\mu\text{m}$  inside diameter). Injection pipettes had tips about 2  $\mu\text{m}$  in outside diameter that were ground to a bevel and then siliconized for 12 h at room temperature in the vapor phase from concentrated SurfaSill (Pierce Chemical Co., Rockford, Ill.). Injection pipettes were back loaded with a Hamilton syringe. The microscopic cell holder and injection pipette were controlled by DeFonbrune pneumatic micromanipulators. An Olympus inverted phase-contrast microscope with a movable stage was mounted on a vibration-free platform (Kinetics Systems). Mouse ova were placed in medium described by Whitten and Biggers (83) with 21 mM *N*-2-hydroxyethylpiperazine-*N'*-2-ethanesulfonic acid (pH 7.4) and 4.2 mM  $\text{NaHCO}_3$  in place of 25 mM  $\text{NaHCO}_3$  and injected within 30 min. From 1 to 3 pl of DNA solution was injected per nucleus, as calculated

from the amount of injected DNA extracted from the embryos and quantitated by hybridization (dot-blot assay). A successful injection was recognized by expansion of the nucleus. From 30 to 50% of the injected embryos lysed within 30 min and were discarded. The surviving embryos were cultured as described above.

**Extraction of viral and plasmid DNA from injected ova.** At various times after injection, ova were transferred to 40  $\mu$ l of sterile DNA isolation buffer (10 mM Tris [pH 7.8], 150 mM NaCl, 5 mM EDTA, and 2  $\mu$ g of salmon sperm DNA [purified and sheared] per ml) lysed in 0.5% SDS, and then incubated with 100  $\mu$ g of proteinase K at 37° for 2 h. The lysate was adjusted to 1 M potassium acetate, 0.67 M acetic acid, and 0.1 N NaOH (pH 5.0) (5) and incubated at 0°C for 15 min before centrifuging in a horizontal rotor (Beckman Microfuge 12) at 12,000  $\times$  g for 15 min at room temperature. Supernatants were extracted with phenol and chloroform (52) before being adjusted to 100  $\mu$ g of yeast tRNA (Bethesda Research Laboratories, Inc., Gaithersburg, Md.) per ml, and the DNA was precipitated overnight in 70% ethanol (-20°C). The DNA was sedimented as described above, suspended in 2% ammonium acetate (pH 7.0), and precipitated in 70% ethanol.

**Detection of DNA replication by sensitivity to *DpnI* restriction endonuclease.** DNA samples were suspended in 20  $\mu$ l of 50 mM Tris (pH 7.5)-100 mM NaCl-10 mM MgCl<sub>2</sub>-1 mM dithiothreitol-100  $\mu$ g of sterile gelatin per ml (52). One half of each sample was digested with 3 U of *SalI* restriction endonuclease while the other half was digested with 3 U of *SalI* plus 3 U of *DpnI*. Each sample contained a total of about 80 ng of DNA. Samples were incubated at 37°C for 1 h before digestion was terminated in 25 mM EDTA, and the DNA was fractionated by electrophoresis at room temperature in a 0.6% agarose gel (8 by 8 by 0.5 cm) in Tris-borate buffer (pH 8.0) (52) at 5 V/cm. Gels were treated so as to fragment the DNA (81) and then transferred to nitrocellulose (Millipore Corp.) as described by Southern (73). Hybridization was carried out as described below.

**Quantitative analysis of DNA by dot-blot hybridization.** Embryos were transferred to 40  $\mu$ l of sterile DNA isolation buffer (see above) supplemented with 8  $\mu$ g of *E. coli* 011 [<sup>3</sup>H]DNA (5.5  $\times$  10<sup>4</sup> cpm/ $\mu$ g) per ml, and the injected DNA was extracted as described above. Recovery of DNA during the purification procedure was determined from the recovery of [<sup>3</sup>H]DNA, and all dot-blot data were corrected accordingly. The final ethanol precipitate was suspended in 230  $\mu$ l of 10 mM Tris (pH 7.6)-100 mM NaCl-1 mM EDTA. Samples were adjusted to 0.2 N NaOH, 1.2 M NaCl, 0.1 M sodium citrate, 6 mM Tris hydrochloride, 0.6 mM EDTA, and heated at 80°C for 20 min to denature the DNA before it was rapidly cooled on ice and neutralized by the addition of 2 M Tris hydrochloride to a final concentration of 0.24 M. Samples were applied to nitrocellulose membranes (58 cm<sup>2</sup>) with a dot-blot manifold (Minifold SRC-96; Schleicher & Schuell Inc., Keene, N.H.), and the wells were washed with standard saline citrate (15 mM sodium citrate [pH 7.0], 0.15 M NaCl). DNA standards (0.5 to 50 pg) were subjected to the same treatment and applied to the same membrane. A linear relationship between the amount of DNA and the areas recorded under densitometer tracings of autoradiograms was established which was valid to about 0.2 pg of DNA (see Fig. 4A). The filter was dried at 80°C under vacuum for 2 h and then prehybridized at 68°C for 6 h in 12 ml of 1 part solution A (0.3 M Tris hydrochloride [stock pH 7.5], 1.5 M NaCl, 5 mM EDTA, 0.2 M Na<sub>2</sub>HPO<sub>4</sub> [stock pH 6.7], 0.2% Na<sub>4</sub>P<sub>2</sub>O<sub>7</sub>, 0.2% SDS, and 400  $\mu$ g of heat-denatured salmon sperm DNA

per ml), and 1 part 20 $\times$  Denhardt solution (0.4% bovine serum albumin, 0.4% Ficoll 400, 0.4% polyvinylpyrrolidone). This solution was decanted, and the membranes were sealed in plastic bags containing 3 ml of 1 part solution A, 0.25 parts 20 $\times$  Denhardt solution, 0.75 parts water, and 5  $\times$  10<sup>7</sup> cpm of heat-denatured [<sup>32</sup>P]DNA probe (10<sup>9</sup> cpm/ $\mu$ g) and incubated at 68°C for 12 h. [<sup>32</sup>P]DNA probes were prepared by nick translation of purified viral or plasmid DNA (68). Each membrane was then washed twice at room temperature for 30 min with 0.5 $\times$  solution A without salmon sperm DNA, twice at 68°C for 1 h with 0.12 $\times$  standard saline citrate and 0.5% SDS, and once at 68°C for 0.5 h with the same solution supplemented with 0.5% SDS. The membranes were dried on Whatman 3MM filter paper and exposed to preflashed Kodak XR-5 film together with an intensifying screen at -70°C (46). The relative intensities of the spots on the resulting autoradiograms were determined by densitometry with a Joyce-Loebl microdensitometer.

## RESULTS

**PyV DNA sequences replicate in one-cell mouse embryos but not in oocytes.** After ovulation, mouse chromosomal DNA replication was first observed in one-cell embryos (i.e., fertilized eggs; see Fig. 3). To determine whether these cells replicated specific DNA sequences, two circular, double-stranded DNA plasmids (pB1a and pML-1) were coinjected into the male pronucleus. Plasmid pML-1 is a derivative of *E. coli* plasmid pBR322 and does not replicate when transfected into mouse fibroblasts. Plasmid pB1a is a complete PyV genome cloned into pML-1 such that the PyV early genes (large, middle, and small T-antigens) are expressed and the PyV origin of replication (*ori*) is functional when transfected into mouse fibroblasts (data not shown). Surviving embryos were cultured in vitro for up to 72 h. At each time point, one-cell embryos were segregated from the two-cell embryos that developed in vitro, and the injected DNA was isolated. Half of the DNA was converted into linear molecules that were one genome in length by cutting at the unique *SalI* restriction site in pML-1, and half was digested with both *SalI* and *DpnI* restriction endonucleases. Both samples were then fractionated by gel electrophoresis, and the DNA was detected by blotting-hybridization with pML-1 [<sup>32</sup>P]DNA used as a probe. Replication of injected DNA was detected by the loss of *DpnI*-sensitive restriction sites. *DpnI* recognition sites that were methylated by propagation of plasmids in *dam*<sup>+</sup> *E. coli* were completely susceptible to cleavage by *DpnI*. However, one or more rounds of replication in mammalian cells, which lack this methylase, resulted in hemimethylated and then unmethylated DNA, both of which were completely resistant to *DpnI* (45, 66).

Replication of injected DNA depended on the presence of PyV sequences. The amount of pB1a DNA increased about 10-fold and became resistant to digestion with *DpnI* restriction endonuclease, while the amount of pML-1 DNA present in the same nucleus remained essentially the same and was sensitive to *DpnI* (Fig. 1, lanes A, B, E, F, I, J). Since pB1a contained 25 *DpnI* sites, 17 of which were shared with the pML-1 DNA present in the same nuclei, semiconservative DNA replication involving *cis*-acting PyV sequences must account for the observed increase in pB1a DNA. The majority of DNA replication occurred 24 to 48 h postinjection, a lag period which is in keeping with normal PyV infection of permissive mouse fibroblasts.

Replication of injected DNA did not occur in all the embryos. Uninjected embryos normally underwent only one

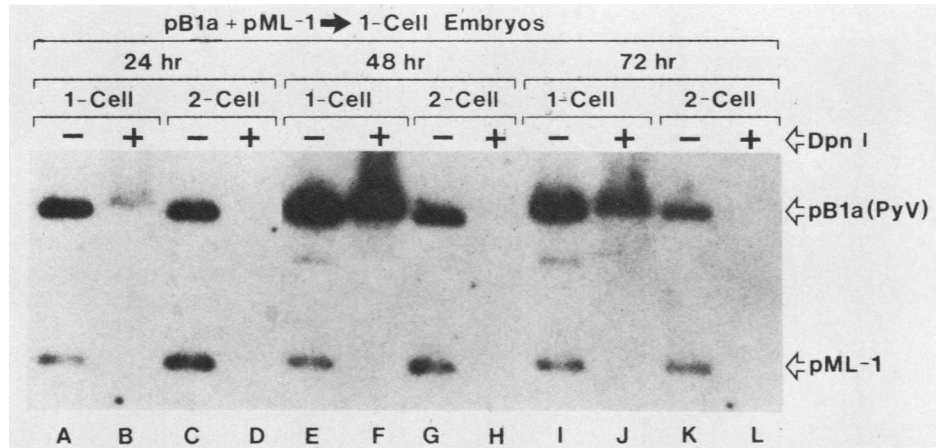

FIG. 1. Sequence-specific DNA replication in mouse one-cell embryos. A mixture of pB1a DNA and pML-1 DNA was injected into the male pronucleus of one-cell embryos. The surviving embryos, containing a total of about 0.5 pg of injected DNA, were divided into three groups and cultured in vitro for the times indicated. The one-cell (lanes A, B, E, F, I, and J) and two-cell (lanes C, D, G, H, K, and L) embryos were segregated. One fraction of each sample was cut at the unique *Sall* restriction site located in the pML-1 sequence of each plasmid to convert all DNA structures into linear molecules that were one genome in length (lanes A, C, E, G, I, and K), and one fraction was digested with both *Sall* and *DpnI* restriction endonucleases to identify those molecules that had replicated and that had thus lost their sensitivity to *DpnI* (lanes B, D, F, H, J, and L). The DNA was fractionated by gel electrophoresis, blotted onto nitrocellulose, and hybridized with pML-1 [<sup>32</sup>P]DNA, and the results were visualized by autoradiography. The number of embryos analyzed in each lane varied: lanes A and B, 13 embryos; lanes C and D, 21 embryos; lanes E and F, 10 embryos; lanes G and H, 20 embryos; lanes I and J, 11 embryos; lanes K and L, 19 embryos.

cleavage in vitro (two-cell block) (61), but about 40% of the injected embryos failed to divide even once, and these one-cell embryos were the only ones that replicated pB1a DNA (Fig. 1). Since the amount of pML-1 DNA in one- and two-cell embryos remained essentially the same throughout the experiment, plasmid DNA replication may have inhibited cell cleavage.

Similar experiments were carried out with growing mouse

oocytes which do not replicate their chromosomal DNA. A total of 0.6 pg of pB1a and pML-1 DNA was injected into the germinal vesicle, and the surviving oocytes were cultured in vitro for up to 48 h. No replication of either plasmid was detected, even when the combined DNA extracted from 90 oocytes was analyzed as described above (data not shown). Under these conditions, the *DpnI* assay detected pB1a replication in a single one-cell embryo. No significant degradation of the injected DNA was detected, and both early and late SV40 genes were expressed efficiently (Chalifour et al., manuscript in preparation). Thus, replication of injected DNA appeared to depend on the presence of cellular factors not expressed in mouse oocytes.

**Replication of DNA in two-cell mouse embryos is sequence dependent.** In contrast to mouse one-cell embryos, which develop only to the two-cell stage, the majority (60 to 80%) of two-cell embryos develop into morphologically normal blastocysts (five to six cell cleavages) when cultured in vitro for up to 72 h (42). Therefore, DNA was injected into two-cell embryos to determine whether the ability of mouse cells to support replication of injected DNA changed during embryogenesis. Either pB1a and pML-1 or pJYM and pML-1 DNA were coinjected into one of the nuclei of

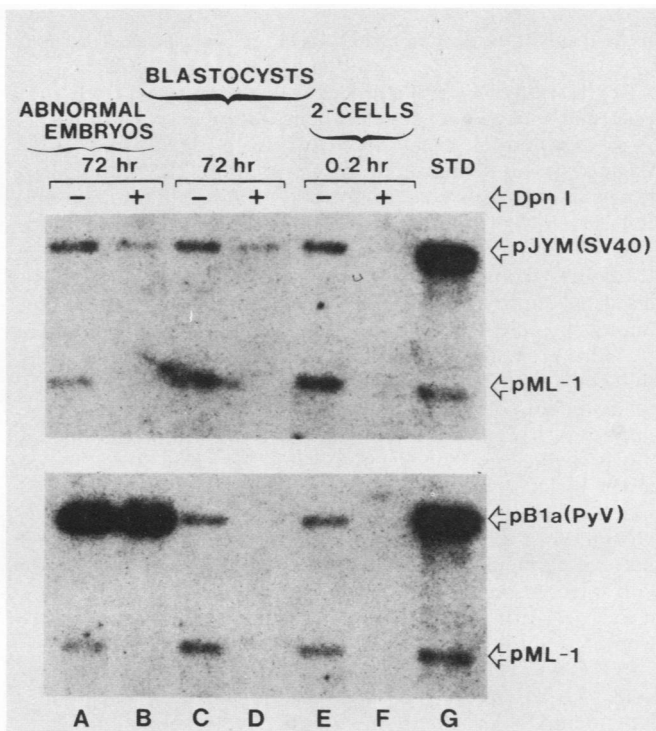

FIG. 2. Sequence-specific replication of DNA injected into mouse two-cell embryos. A mixture of either pJYM and pML-1 (top panel) or pB1a and pML-1 (bottom panel) DNA was injected into the nucleus of one of the two blastomeres. Each embryo received a total of about 0.6 pg of DNA, and the survivors were cultured in vitro for either 0.2 or 72 h. DNA was extracted from morphologically normal blastocysts (lanes C and D) and morphologically abnormal embryos (lanes A and B). As in Fig. 1, the injected DNA was extracted, and one fraction of each sample was digested with *Sall* (lanes A, C, and E) and one fraction was digested with *Sall* and *DpnI* (lanes B, D, and F). Purified pJYM, pB1a, and pML-1 DNA were cut with *Sall* and used as standards (lane G). Each lane contained DNA from five embryos.

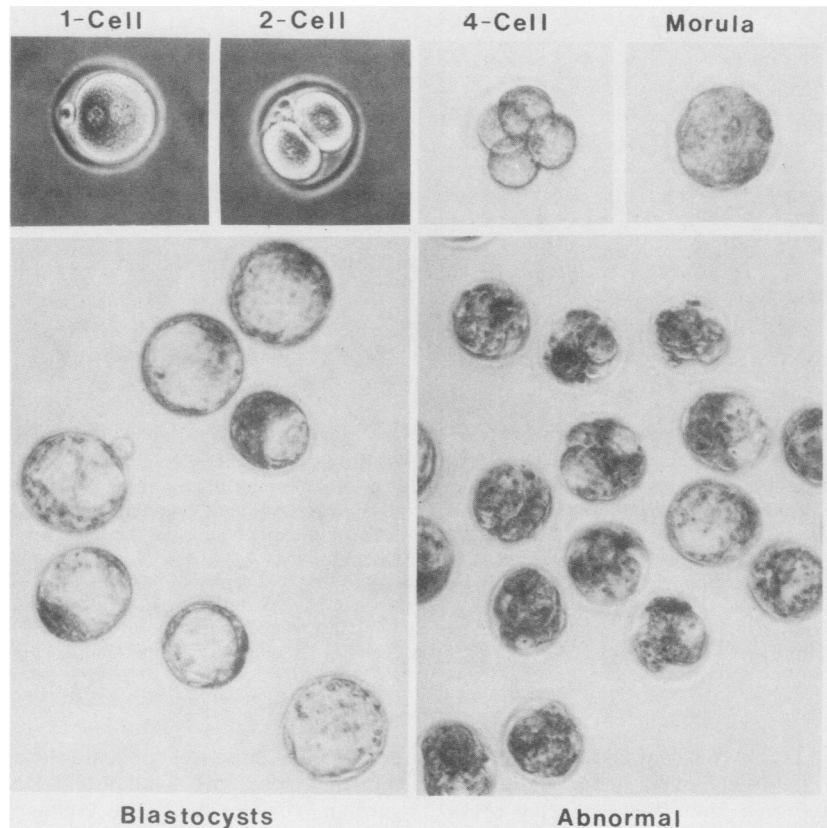

FIG. 3. Mouse embryonic development after injection of DNA. Uninjected one- and two-cell embryos were isolated as described in the text. The male pronucleus is the larger of the two pronuclei evident in the one-cell embryo. The zona pellucida is the thick glycoprotein envelope surrounding each preimplantation embryo. One of the nuclei in two-cell embryos was injected with about 0.6 pg of a mixture of pB1a and pML-1 DNA. The embryos were cultured in vitro, and four-cell embryos (24 h), morula (48 h), blastocysts (72 h), and morphologically abnormal multicellular embryos (72 h) were isolated at the times indicated in parentheses. The outside diameter of embryos from the one-cell to the morula stage is constant (about 80  $\mu\text{m}$ ) and is limited by the zona pellucida. Blastocysts may be significantly larger because of swelling of the blastocoel cavity. Blastocysts and abnormal embryos are exhibited at the same magnification.

two-cell embryos, and surviving embryos were allowed to continue development in vitro. pJYM is a recombinant pML-1 plasmid containing a complete SV40 genome that expresses both large and small T-antigen genes and replicates when transfected into CV-1 monkey cells (data not shown). DNA replication was detected by the *DpnI* assay as described above.

The ability of injected DNA to replicate in developing mouse embryos depended entirely on the sequences present. pML-1 DNA did not replicate, whether it was injected alone (data not shown) or together with either pJYM (Fig. 2, top panel) or pB1a (Fig. 2, bottom panel), although it was stable for up to 72 h. In contrast, pB1a replicated extensively in mouse embryos. pB1a DNA was completely sensitive to *DpnI* cleavage at 0.2 h postinjection (Fig. 2, lane F), indicating that little, if any, of this DNA had replicated at that time. After 72 h of incubation, the amount of pB1a DNA increased approximately sevenfold (Fig. 2, cf. lanes E and A), and the DNA was completely resistant to cleavage by *DpnI* (Fig. 2, lane B). SV40 sequences also allowed pML-1 DNA to replicate, but to a much lesser extent than that observed with PyV. pJYM DNA, which contained 25 *DpnI* sites, was completely sensitive to *DpnI* cleavage at 0.2 h after injection (Fig. 2, lane F). By 72 h postinjection, about 20% of pJYM was resistant to *DpnI*, while coinjected pML-1 DNA remained completely sensitive (Fig. 2, cf. lanes A and C with B and D), although little, if any, change was detected

in the total amount of pJYM DNA (Fig. 2, cf. lanes A, C, and E).

Replication of PyV sequences was always associated with abnormal embryonic development, whereas replication of SV40 sequences was observed in both normal (i.e., blastocysts) and abnormal embryos (Fig. 2). Noninjected mouse 2-cell embryos progress to the 4-cell, 8-cell, and morula (16- to 32-cell) stages during the first 48 h in culture (Fig. 3). Between 48 and 72 h, when noninjected embryos developed from morula to blastocysts (64 to 128 cells), abnormal embryonic development became most apparent among the injected embryo population. Blastocysts had a distinctive blastocoel cavity enclosed by trophoblast cells uniformly distributed along the inner surface of the zona pellucida. In contrast, abnormal embryos contained a large number of irregularly organized cells that often contained a poorly defined blastocoel cavity (Fig. 3). From 10 to 20% of newly isolated two-cell embryos developed this abnormal multicellular appearance, whereas 40 to 90% of embryos injected with 0.3 to 1 pg of pB1a DNA produced abnormal multicellular embryos. Thus, as was observed previously with injected one-cell embryos, either extensive replication of PyV DNA or expression of PyV gene products apparently promoted abnormal embryonic development.

**PyV DNA replication is independent of embryonic development.** To compare the time course for PyV sequence-dependent DNA replication with the developmental progress



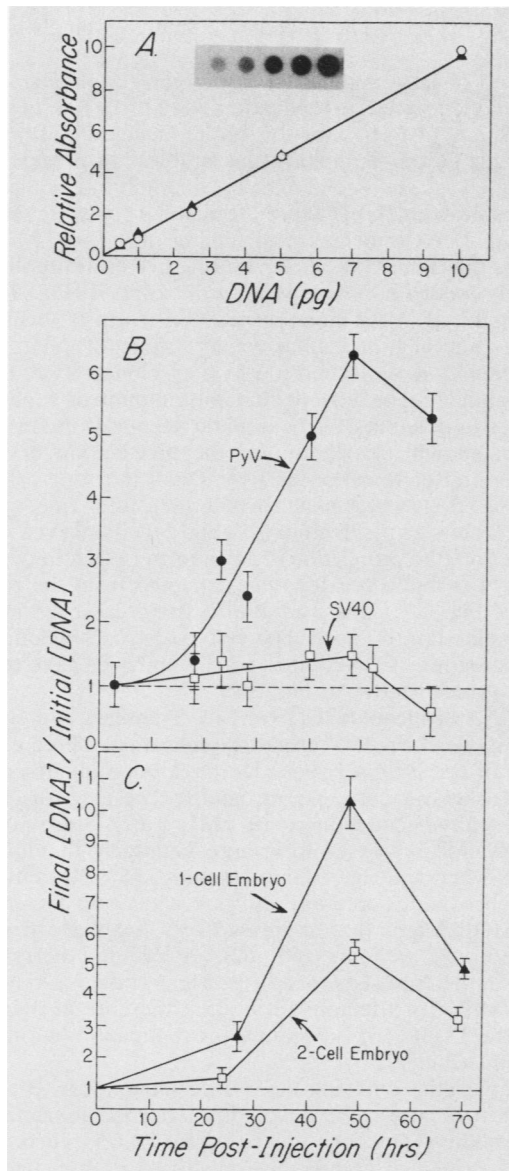

FIG. 4. Time course for the replication of PyV and SV40 sequences after microinjection into mouse embryos. (A) Each dot-blot included a standard curve. Open circles and closed triangles represent values taken from two duplicate experiments. (B) A mixture of PyV and SV40 form I DNA was injected into one of the nuclei in two-cell embryos, and the surviving embryos were cultured in vitro. Viral DNA was isolated from groups of five embryos at various times after injection (Final [DNA]), and DNA was quantitated by dot-blot hybridization with PyV (closed circles) or SV40 (open circles) [ $^{32}$ P]DNA. Initial concentrations (15 min) of viral DNA were  $1.5 \pm 0.4$  and  $1.6 \pm 0.4$  pg per embryo, respectively, and defined as unity (dashed line; Initial [DNA]). Only three-cell embryos were used in this analysis. Bars at each point reflect the variation inherent in the extraction and hybridization procedures and were obtained by dividing the embryonic lysate in two and assaying each fraction separately. (C) Plasmid pB1a was injected into the male pronucleus of one-cell embryos (closed triangles) and one of the nuclei of two-cell embryos (open squares), and the amount of pB1a DNA present at the indicated times postinjection was determined as described above. DNA concentrations were measured on groups of 12 embryos. Initial DNA concentrations (dashed line) were  $0.3 \pm 0.1$  (one-cell) and  $0.6 \pm 0.2$  (two-cell) pg pB1a DNA per embryo. In the one-cell experiment, only one-cell embryos were analyzed. In the two-cell experiment, three-cell embryos were collected at 24 h

of injected embryos, two-cell embryos were injected with a mixture of PyV and SV40 form I DNA, and surviving embryos were cultured for various periods of time before the injected DNA was extracted, applied to a nitrocellulose filter, and hybridized with either PyV or SV40 [ $^{32}$ P]DNA (dot-blot assay, Fig. 4A). After a lag period of about 20 h, PyV DNA increased about sixfold, while SV40 DNA, present in the same nucleus, increased 20% (Fig. 4B). Because of the high concentration of injected DNA, these two-cell embryos failed to develop beyond the three-cell stage. Nevertheless, the time course for PyV DNA replication in embryos that failed to develop past the three-cell stage (Fig. 4B) was essentially the same as that observed for pB1a injected into either one- or two-cell embryos (Fig. 4C). In those experiments, injected one-cell embryos failed to develop into two-cell embryos, and injected two-cell embryos developed into abnormal multicellular embryos. Therefore, replication of PyV DNA was not a function of the progress of embryonic development. Presumably, the delay between injection and replication of DNA reflected a requirement for production and organization of required replication components, analogous to a normal PyV lytic cycle in mouse differentiated cells.

The differences observed in developmental progress of two-cell embryos in Fig. 4B and C were related to the amount of DNA injected. Development was arrested at the three-cell stage whenever 2 to 3 pg of either viral DNA or plasmid DNA was injected, regardless of sequence composition. This represented up to 50% of the nuclear DNA content. Therefore, in most experiments, 0.3 to 0.6 pg of DNA was injected per nucleus to allow more extensive development.

The results obtained by coinjecting PyV and SV40 form I DNAs (Fig. 4B) into two-cell embryos (Fig. 4A) were also obtained with pB1a and pJYM (data not shown), demonstrating that the results of microinjection were not unique to either viral or plasmid DNA preparations. Furthermore, these results show that PyV sequences are unable to stimulate SV40 DNA replication and SV40 sequences do not interfere with PyV replication. The fact that the amount of viral DNA decreased at 72 h postinjection reveals that some DNA is either eventually degraded or that some DNA is no longer extractable under conditions used in this study because it integrated into cellular DNA or recombined into large oligomers.

**Injected DNA undergoes conformation changes.** Form I DNA underwent changes in superhelical density immediately after injection that were consistent with assembly of injected DNA into chromatin. PyV DNA was injected into one-cell embryos and extracted at various times thereafter and fractionated by gel electrophoresis, and the results were visualized through blotting hybridization with PyV [ $^{32}$ P]DNA (Fig. 5A). Before injection, more than 95% of the DNA was form I (Fig. 5A, lane STD). However, within 0.2 h after injection, most PyV DNA migrated as topologically relaxed circular DNA (form II), while a small fraction failed to enter the gel. From 6 to 18 h later form I DNA reappeared, first as a series of topological isomers and then as fully

postinjection, four-cell or greater embryos were collected at 48 h postinjection, and abnormal multicellular embryos were collected at 72 h postinjection. The other developmental categories of embryos taken at each time point did not exhibit DNA replication.

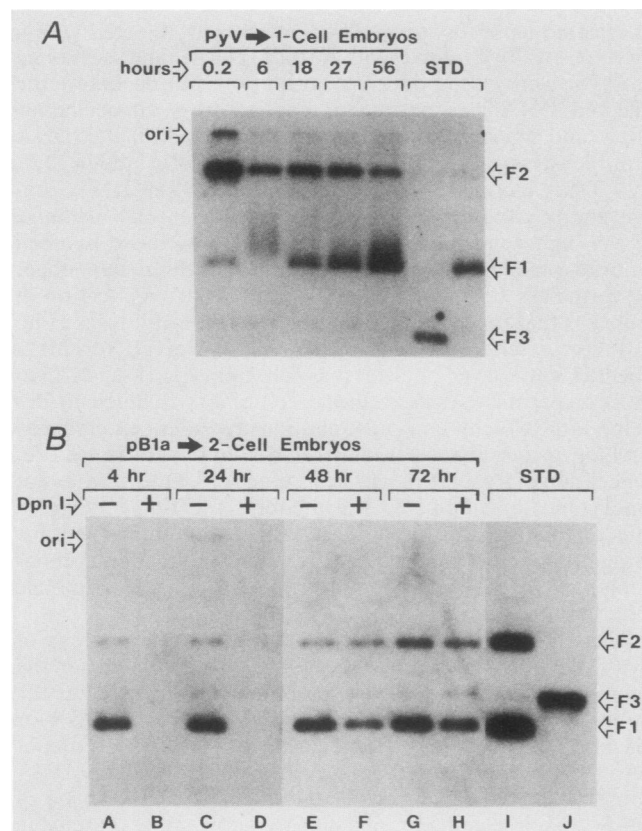

FIG. 5. Conformation of DNA injected into the nuclei of one- and two-cell embryos. (A) The male pronucleus of each one-cell embryo was injected with about 12 pg of PyV DNA, and surviving embryos were cultured *in vitro* in five groups. DNA was purified, fractionated by gel electrophoresis, transferred to nitrocellulose, and hybridized with PyV [<sup>32</sup>P]DNA. DNA from an average of 10 embryos was analyzed at each time point. Development did not progress beyond the two-cell stage. (B) One of the nuclei in each two-cell embryo was injected with about 0.3 pg of pB1a DNA, and the surviving embryos were cultured *in vitro* in four groups. At each time point after injection one group of embryos was segregated according to their developmental state, and their DNA was extracted and analyzed as described above. One-half of the sample was analyzed directly (lanes A, C, E, and G), and the other half was digested with *DpnI* (lanes B, D, F, and H) to determine the fraction of each DNA species that replicated (i.e., became resistant to *DpnI*). Lanes A and B contained DNA from 10 two-cell embryos, lanes C and D contained DNA from 11 four-cell embryos, lanes E and F contained DNA from 18 >four-cell embryos, and lanes G and H contained DNA from 24 abnormal multicellular embryos. The gels described in panels A and B contained 1.5 and 0.6% agarose, respectively. Therefore, the relative mobilities of the three forms of DNA were different in the two experiments (52). Form I DNA (F1) is circular, covalently closed superhelical DNA. Form II DNA (F2) is circular, topologically relaxed DNA. Form III DNA (F3) is linear DNA one genome in length.

supercoiled molecules. Similar observations were made with SV40 DNA injected into mouse oocytes (manuscript in preparation) and two-cell embryos (data not shown), demonstrating that DNA replication is not required for this transition to be observed. Similar changes also have been observed with DNA injected into *Xenopus* oocytes (32, 59, 84) and eggs (47) and have been shown to result from the organization of injected DNA into chromatin. In contrast to the relative stability of DNA injected into nuclei, at least 90% of form I DNA injected into the cytoplasm of one- or

two-cell embryos was degraded completely within 24 h (data not shown).

**Products of DNA replication are circular monomers.** The major products of DNA replication were form I and form II DNA, typical of PyV infection of permissive differentiated mouse cells (20; DePamphilis and Bradley, in press). pB1a was injected into two-cell embryos, and half of each sample was digested with *DpnI* before electrophoresis to reveal the fraction of DNA that had replicated. From 4 to 72 h after injection, the dominant conformations of both unreplicated and newly replicated DNA were forms I and II (Fig. 5B). A trace amount of linear monomeric DNA (form III) was also detected, but high-molecular-weight forms of pB1a were absent. Injection of plasmid pJYM (i.e., cloned SV40 DNA) gave a similar result except that the amount of replicated DNA was only about 3% the amount seen with pB1a DNA (data not shown). Furthermore, the distribution of DNA conformers after injection of PyV DNA into one-cell embryos (Fig. 5A) was similar to that seen after injection of pB1a DNA into two-cell embryos (Fig. 5B). However, at 4 h postinjection, the proportion of pB1a form I DNA in two-cell embryos was much greater than expected from the results shown in Fig. 5A. This was due to the greater amount of DNA injected into those one-cell embryos; injection of smaller amounts of DNA into one-cell embryos gave results similar to those shown in Fig. 5B.

**PyV DNA replication requires PyV T-antigen and specific configurations of the PyV origin of replication.** Three configurations of the PyV *ori* sequence have been identified and referred to as  $\alpha$ - $\beta$ -core,  $\alpha$ -core, and  $\beta$ -core (Fig. 6). These sequences have been cloned into pML-1 (62). Since none of these plasmids expressed PyV large T-antigen, they did not replicate when transfected into mouse 3T6 cells, but  $\alpha$ - $\beta$ -core,  $\alpha$ -core, and  $\beta$ -core did replicate when transfected into mouse MOP-8 cells that expressed PyV T-antigen from an integrated PyV genome (60, 62). A plasmid carrying a deletion in the core sequence ( $\alpha$ - $\beta$ ; Fig. 6) failed to replicate in either cell type, demonstrating that the core element, as well as the T-antigen, is required for replication in differentiated mouse cells.

When plasmids carrying the  $\beta$ -core sequence ( $\alpha$ - $\beta$ -core<sup>+</sup>,  $\alpha$ - $\beta$ -core, or  $\beta$ -core) were injected into one of the nuclei of a two-cell embryo and then incubated for 72 h *in vitro*, all of the DNA remained completely sensitive to *DpnI* digestion (Fig. 7, lanes A through D), demonstrating their inability to replicate in mouse embryos. However, when each of these plasmids was coinjected along with pB1a which encodes small, middle, and large PyV T-antigens, each of the three plasmids replicated along with pB1a DNA (Fig. 7, lanes E, F, and I through N).  $\alpha$ - $\beta$ -Core<sup>+</sup> failed to replicate alone (Fig. 7, lanes A and B), despite the fact that it encoded small and middle T-antigens (60), but did replicate when coinjected with pB1a (Fig. 7, lane L). Therefore, pB1a allowed PyV *ori*-containing plasmids to replicate by providing large T-antigen.

Sequences within the core element were also required for replication of PyV DNA in mouse embryos. Plasmid  $\alpha$ - $\beta$  failed to replicate even when it was coinjected with pB1a, while both  $\beta$ -core and pB1a DNA, present in the same nucleus, did replicate (Fig. 7, lanes M and N). When the parent plasmid for  $\alpha$ - $\beta$ ,  $\alpha$ - $\beta$ -core<sup>+</sup>, was coinjected with pB1a and  $\alpha$ -core, both pB1a and  $\alpha$ - $\beta$ -core<sup>+</sup> DNA replicated as expected (Fig. 7, lanes K and L).

Surprisingly, the  $\alpha$ -core configuration of PyV *ori* failed to replicate in embryos, even when T-antigen was provided by coinjecting it with pB1a. Only pB1a DNA replicated and

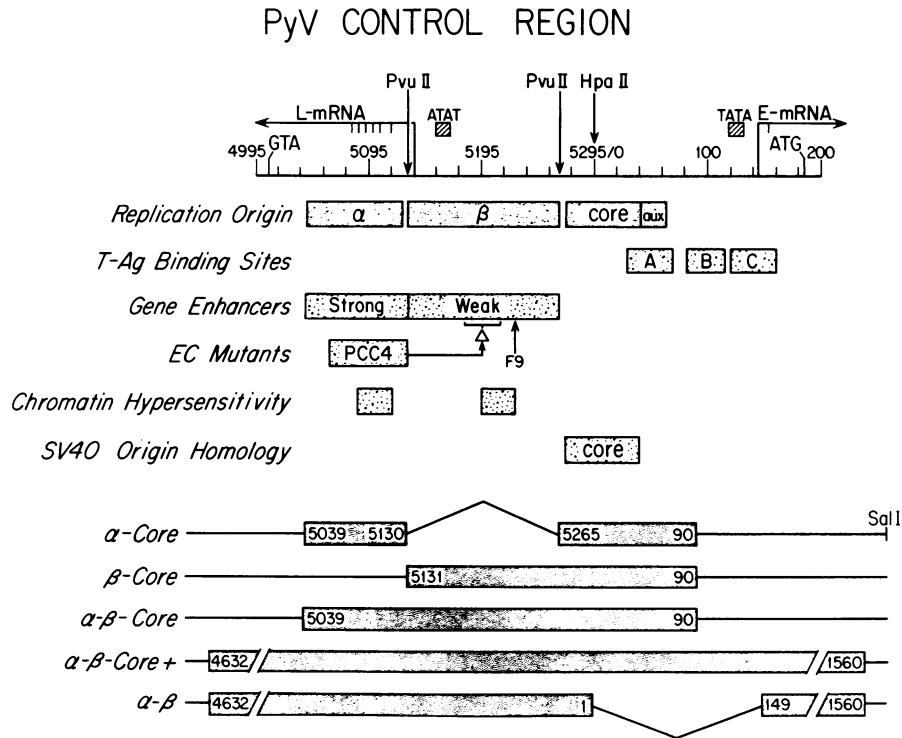

FIG. 6. PyV control region and cloned PyV DNA sequences. The scale of the PyV control region is in base pairs. The *cis*-acting sequences that comprise the PyV origin of replication (*ori*), referred to as α, β, core, and auxiliary (DePamphilis and Bradley, in press), were defined from the data of Muller et al. (62), Katinka and Yaniv (43), Luthman et al. (51), and Tyndall et al. (79). The relationships between PyV *ori* and the PyV large T-antigen (T-Ag) binding sites (16, 24, 67), strong and weak gene enhancer elements (21, 22, 37, 48, 60, 79), host range mutations that allow replication in mouse EC cells (29, 72, 80), DNase I hypersensitive chromatin sites (38), SV40 *ori* (20; DePamphilis and Bradley, in press), and PyV transcription and translation initiation signals (17, 41, 60) are shown. PyV mutants that grow on EC PCC4 cells carried a duplication of a portion of the α-element which substituted for a deleted portion of the β-element. The F9 mutant is a single point mutation that allows PyV to grow on EC F9 cells and converts the β-element into a strong enhancer (48). Cloned PyV sequences that were injected into mouse embryos have been described by Muller et al. (62) and are diagrammed as shaded bars. The PyV map position of the nucleotide at each border is given by the numbers inside the bars.

thus became *DpnI* resistant (Fig. 7, lanes G, H, K, and L). These experiments were repeated four times; and each time α-core did not replicate, although β-core and α-β-core did replicate along with the pBla DNA present in the same nucleus. To ensure that the α-core plasmid, as well as α-β-core and β-core plasmids, replicated in differentiated mouse cells, these plasmids were transfected into MOP-8 cells, and their ability to replicate was measured by the *DpnI* assay. All three PyV *ori* configurations replicated as reported previously (62). Therefore, in the presence of PyV large T-antigen, α-core was recognized as a PyV *ori* sequence in differentiated mouse cells but not in mouse embryos, while α-β-core and β-core were recognized as *ori* sequences in both differentiated and embryonic cells.

**DISCUSSION**

**Requirements for PyV DNA replication during mouse development.** Results presented here demonstrate that the requirements for papovavirus DNA replication in mouse embryonic cells are essentially the same as those in differentiated mouse cells. Sequences within the 254-base-pair region of PyV *ori* that contain the β and core elements (Fig. 6) were essential for initiation of PyV DNA replication in mouse embryos and functioned only when the gene-encoding large T-antigen was present either on the same or another DNA molecule. The T-antigen requirement was consistent with the fact that multiple rounds of PyV DNA

replication occurred even in the absence of cell division (e.g., one-cell embryos that remained at the one-cell stage and two-cell embryos that did not proceed beyond the three-cell stage). Permissive cell factors required for PyV DNA replication were absent in the oocyte but were present in the one-cell embryo. The fact that SV40 DNA replication was marginal (discussed below) compared with that of PyV, regardless of the presence or absence of actively replicating PyV DNA, confirmed that permissive cell factors in mouse embryos are specific for PyV. Regardless of the initial or final developmental state of the embryo, the time courses for replication after injection of PyV DNA were similar, implying that permissivity for PyV DNA replication does not significantly change during the first few cell divisions after fertilization (Fig. 4). The initial delay in DNA replication of about 20 h most likely represents a requirement for the synthesis of T-antigen and assembly of a replication complex. Embryonic development was arrested at different stages, depending on the amount of DNA injected and whether it replicated extensively or expressed PyV gene products or both. These conditions were apparently toxic to the injected cell, eventually resulting in cell death, cessation of DNA replication, and degradation of newly replicated DNA. Interestingly, the time course for PyV DNA replication after injection into embryos was remarkably similar to that observed on transfection of differentiated mouse cells.

Results of other studies suggest that embryonic mouse



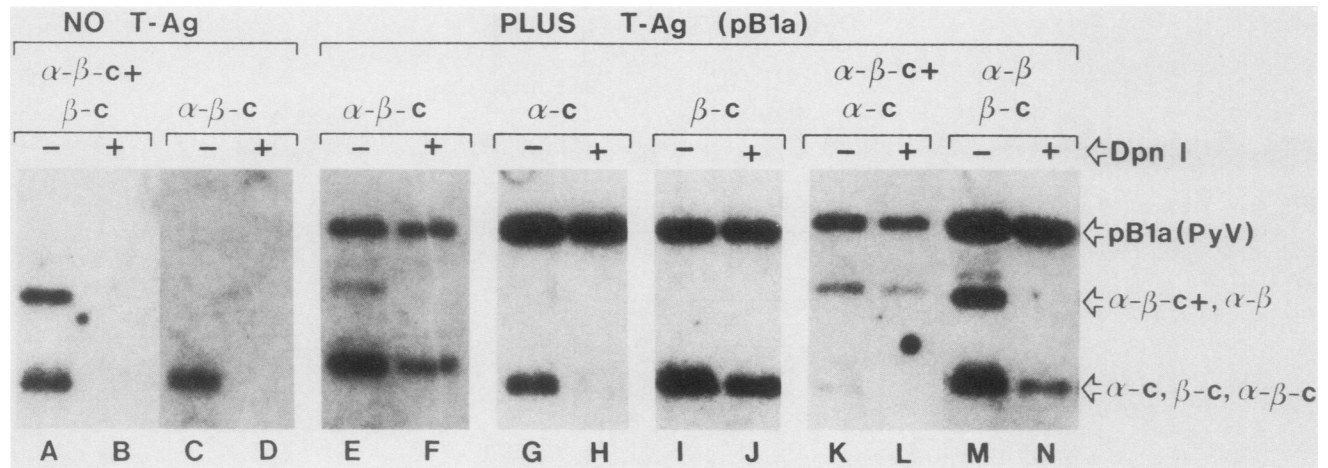

FIG. 7. Sequence requirements for PyV DNA replication in mouse embryos. pML-1 plasmids carrying various elements of the PyV *ori* sequence (Fig. 6) were injected into one of the nuclei of two-cell embryos. In some cases, an active PyV T-antigen (T-Ag) gene was absent (lanes A through D), while in other experiments PyV T-antigen was provided *in trans* by coinjecting these plasmids with pB1a (lanes E through N). Each embryo received a total of about 0.3 pg of DNA, and surviving embryos were cultured *in vitro* for 72 h. As described earlier (Fig. 2 and 4), DNA was isolated and then digested either with *Sall* alone (-) or with both *Sall* and *DpnI* (+) to determine the total fraction of DNA that replicated. Embryos were injected with the following plasmids (in the figure, c represents core):  $\beta$ -core and  $\alpha$ - $\beta$ -core<sup>+</sup> (lanes A and B);  $\alpha$ - $\beta$ -core (lanes C and D);  $\alpha$ - $\beta$ -core and pB1a (lanes E and F);  $\alpha$ -core and pB1a (lanes G and H);  $\beta$ -core and pB1a (lanes I and J);  $\alpha$ -core,  $\alpha$ - $\beta$ -core<sup>+</sup>, and pB1a (lanes K and L);  $\beta$ -core,  $\alpha$ - $\beta$ , and pB1a (lanes M and N). Abnormal embryos and blastocysts were segregated and analyzed separately, but DNA replication was detected only in the abnormal embryos (lanes A through N). Lanes A and B received DNA from 15 embryos; lanes C and D received DNA from 12 embryos; lanes E and F received DNA from 10 embryos; lanes G and H received DNA from 13 embryos; lanes I and J received DNA from 15 embryos; lanes K and L received DNA from 25 embryos; and lanes M and N received DNA from 15 embryos.

cells are not permissive for PyV DNA replication (44). PyV DNA replication and expression of viral genes were not observed after infection of mouse embryos and mouse EC cells with PyV virions. In fact, the level of transcription in one- and two-cell embryos is minimal (15, 42), which would presumably make the expression of foreign genes difficult. However, metallothionein-thymidine kinase genes injected into mouse one-cell embryos have been expressed in a regulated manner (10). Similarly, Newport and Kirschner (64) have shown that genes injected into transcriptionally quiescent *Xenopus* eggs are transiently expressed. The difference between our results and results of previous studies on PyV replication in mouse embryonic cells may be related to the method of introducing DNA into the cell. We injected about 100,000 copies of bare DNA directly into embryonic nuclei. Although the DNA appeared to be assembled into chromosomes, it may have lacked modifications used by the cell to inactivate transcription. Alternatively, the large number of T-antigen gene copies may have compensated for inefficient viral DNA replication or transcription.

Since mouse embryos support replication of PyV DNA in the same manner as do differentiated mouse cells, the occurrence of SV40 DNA replication at a level of about 3% of that observed for PyV DNA was surprising. SV40 DNA replication was not detected in mouse fibroblasts, although a small number of viral DNA concatamers has been observed even in the absence of active T-antigen (14). In mouse embryos, the products of SV40 DNA replication are circular DNA monomers. It is not yet clear whether SV40 T-antigen and the *ori* sequence are required for replication in embryos. Thus, SV40 replication may represent either a low level of T-antigen-dependent viral DNA replication that results from the large number of viral DNA molecules injected or it may be analogous to replication of a cellular *ori* sequence similar to the one described by Ariga et al. (3).

**Cell-specific PyV *ori* sequences.** The  $\beta$ -core configuration of the PyV origin of replication was functional in mouse embryos, but the  $\alpha$ -core configuration was not. In differentiated mouse cells, however, both constructions functioned as PyV origins of replication, as previously reported (62). The difference may be related to the recognition of specific transcriptional enhancer sequences in embryonic and differentiated cells. The *cis*-acting sequence required for the PyV origin of replication contains sequences that act as gene enhancers and are encoded within the  $\alpha$ - and  $\beta$ -elements (see above and Fig. 6). In differentiated mouse cells,  $\alpha$  provides a 3-fold higher enhancement than  $\beta$ , whereas in mouse EC cells, the efficiency of  $\beta$  remains the same as in differentiated cells but is decreased by 3.5-fold (37). Thus, enhancement activity of the  $\alpha$  element in mouse embryos may have been diminished relative to that of the  $\beta$  element such that  $\alpha$  no longer functioned as part of *ori*. Consistent with this hypothesis, many mutants of PyV that have been selected for growth on EC cells carry mutations which map within the  $\beta$  element (30, 80). These mutations increase the enhancer activity of the  $\beta$  element in EC cells (48), and at least one of these mutations has been shown to be involved directly in activating the *ori* sequence in EC cells (30). Experiments are now in progress to determine whether the  $\alpha$ - and  $\beta$ -elements function as enhancers for gene expression in mouse embryos and whether the same sequences are required for both replication and enhancer activity.

**Sequence-dependent DNA replication in embryonic cells.** The observations reported here in mouse embryos contrast with those of analogous experiments in *Xenopus* eggs. The ability of DNA to replicate after injection into mouse embryos varied over at least a 200-fold range as a function of sequence, whereas injection of the same or similar molecules into *Xenopus* eggs replicated with little, if any, regard to sequence (58). Perhaps the critical difference between *Xen-*

*opus* and mouse embryos is the inherent difference in their rates of development. *Xenopus* embryos, after a 90-min postfertilization delay, divide once every 35 min (63), whereas cell cleavage in mouse embryos occurs every 17 to 20 h (50, 70). These rates reflect the difference in amounts of maternal mRNA and proteins present in eggs. *Xenopus* eggs support 12 cell cleavages before zygotic transcription occurs (63), but mouse eggs support only the first cell cleavage (4, 27). To accommodate the faster rate of DNA replication, amphibian embryos (and perhaps those of other nonmammalian systems) may utilize a great variety of sequences as origins of replication, perhaps by modifying proteins involved in the initiation process. Alternatively, the high concentration of replication proteins present in nonmammalian embryos may eliminate the advantage that *ori* sequences have over other sequences in promoting initiation of replication.

Although other differences exist between experiments carried out in mouse and *Xenopus* embryos that could account for the apparent contradiction in results, these differences do not appear to be critical. DNA was injected into the nuclei of mouse embryos, but into the cytoplasm of *Xenopus* eggs. The amount of DNA injected into *Xenopus* was 200 to 10,000 times greater than the nuclear DNA present (6 pg), whereas only 0.05- to 2-fold the amount of mouse nuclear DNA (6 pg) was injected into mouse embryos. However, DNA injected into *Xenopus* eggs was rapidly assembled into nucleosomes (47, 64), sequestered into nuclear-like aggregates (28), and replicated under apparent control of the cell division cycle (34), indicating that injected DNA is treated like chromosomal DNA by the cell. Furthermore, given the large amount of stored maternal proteins and mRNA that exist in amphibian ova compared with mammalian ova, the final ratio of injected DNA to cellular components may actually be similar. For example, efficient chromatin assembly and transcription on DNA injected into *Xenopus* oocytes required nanogram quantities of injected DNA (32), presumably to achieve an optimal protein/DNA ratio.

The question whether mammalian cells utilize *ori* sequences to regulate the initiation of DNA replication remains. Our data are consistent with a requirement for *ori* sequences to replicate mammalian chromosomal DNA. Several DNA plasmids (pML-1,  $\alpha$ -core,  $\alpha$ - $\beta$ ) failed to replicate, even in the presence of active PyV DNA replication. These molecules varied in length from 3 to 5 kilobases, constituted less than 10% of the nuclear DNA of the cell, appeared to be assembled into chromosomes, did not interfere with embryonic development, and remained throughout five to six cell divisions. The limit of detection for *DpnI*-resistant DNA was about 0.2 pg per band (Fig. 1 and 2). Thus, in one experiment with 60 embryos per gel lane (data not shown), <1% of the pML-1 DNA may have replicated even once. This is <0.1% the amount of *DpnI*-resistant PyV DNA observed in the same nucleus. In contrast, the amount of injected DNA that replicated in *Xenopus* eggs was comparable to the amount of nuclear DNA that would have replicated during the same time period (58). Thus, if mammalian embryos behaved like *Xenopus* embryos, DNA replication should have been detected in all of these plasmids. Therefore, these plasmids appear to lack *cis*-acting sequences required for efficient initiation of DNA replication in mammalian embryos. Since pML-1 DNA failed to replicate in the absence of a known eucaryotic *ori* sequence, it is possible that cellular *ori* sequences can be identified by their ability to replicate pML-1 or other similar plasmids.

#### ACKNOWLEDGMENTS

We are indebted to Claude Lechene (Harvard Medical School) for providing the facilities to make micropipettes and to David Weaver (Massachusetts Institute of Technology, Cambridge) for sharing expertise in virology and recombinant DNA technology.

This work was supported by Public Health Service grant HD-12275 from the National Institutes of Health, grant MV-114 from the American Cancer Society, and grant 850745 from the American Heart Society. D.O.W. was supported by a fellowship from the National Cancer Institute, and L.E.C. was supported by a fellowship from the Leukemia Society of America.

#### LITERATURE CITED

- Abramczuk, J., D. Solter, and H. Koprowski. 1977. The beneficial effect of EDTA on development of mouse one-cell embryos in chemically defined medium. *Dev. Biol.* 61:378-383.
- Anderson, S., G. Kaufmann, and M. L. DePamphilis. 1977. RNA primers in SV40 DNA replication: identification of transient RNA-DNA covalent linkages in replicating DNA. *Biochemistry* 16:4990-4998.
- Ariga, H., Z. Tsuchihashi, M. Naruto, and M. Yamada. 1985. Cloned mouse DNA fragments can replicate in an SV40 T-antigen dependent system in vivo and in vitro. *Mol. Cell. Biol.* 5:563-568.
- Bensaude, O., C. Babinet, M. Morange, and F. Jacob. 1983. Heat shock proteins, first major products of zygotic gene activity in mouse embryo. *Nature (London)* 305:331-333.
- Birnboim, H. C., and J. Doly. 1979. A rapid alkaline extraction procedure for screening recombinant plasmid DNA. *Nucleic Acids Res.* 7:1513-1520.
- Blumenthal, A. B., H. J. Kiegestein, and D. S. Hogness. 1973. The units of DNA replication in *Drosophila melanogaster* chromosomes. *Cold Spring Harbor Symp. Quant. Biol.* 38:205-223.
- Boccaro, M., and F. Kelley. 1978. Susceptibility of teratocarcinoma cells to simian virus 40 and polyoma virus. *Ann. Microbiol. Institut Pasteur, Paris* 129A:227-238.
- Brinster, R. L. 1965. Lactic dehydrogenase activity in the preimplanted mouse embryo. *Biochim. Biophys. Acta* 110:439-441.
- Brinster, R. L. 1971. Cultivation of the mammalian embryo, p. 252-286. G. H. Rothblat and V. J. Cristofalo (ed.), *In Growth, nutrition, and metabolism of cells in culture*. Academic Press, Inc., New York.
- Brinster, R. L., H. Y. Chen, R. Warren, A. Sarthy, and R. D. Palmiter. 1982. Regulation of methallothionein-thymidine kinase fusion plasmids injected into mouse eggs. *Nature (London)* 296:39-42.
- Calza, R. E., L. A. Eckhardt, T. DeGiudice, and K. C. Schildkraut. 1984. Changes in gene position are accompanied by a change in time of replication. *Cell* 36:689-696.
- Campbell, B. A., and L. P. Villarreal. 1985. Host species specificity of polyomavirus DNA replication is not altered by simian virus 40 72-base-pair repeats. *Mol. Cell. Biol.* 5:1534-1537.
- Chambers, J. C., S. Watanabe, and J. H. Taylor. 1982. Dissection of a replication origin of *Xenopus* DNA. *Proc. Natl. Acad. Sci. USA* 79:5572-5576.
- Chia, W., and P. W. J. Rigby. 1981. Fate of viral DNA in nonpermissive cells infected with simian virus 40. *Proc. Natl. Acad. Sci. USA* 78:6638-6642.
- Clegg, K. B., and L. Piko. 1983. Poly(A) length, cytoplasmic adenylation and synthesis of poly(A)<sup>+</sup> RNA in early mouse embryos. *Dev. Biol.* 95:331-341.
- Cowie, A., and R. Kamen. 1984. Multiple binding sites for polyomavirus large T-antigen within regulatory sequences of polyomavirus DNA. *J. Virol.* 52:750-760.
- Cowie, A., C. Tyndall, and R. Kamen. 1981. Sequences at the capped 5'-ends of polyoma virus late region mRNA: an example of extreme terminal heterogeneity. *Nucleic Acids Res.* 9:6305-6322.
- Dandolo, L., J. Aghion, and D. Blangy. 1984. T-antigen-independent replication of polyomavirus DNA in murine em-

- bryonal carcinoma cells. *Mol. Cell. Biol.* **4**:317-323.
19. **Dandolo, L., D. Blangy, and R. Kamen.** 1983. Regulation of polyoma virus transcription in murine embryonal carcinoma cells. *J. Virol.* **47**:55-64.
  20. **DePamphilis, M. L., and P. M. Wassarman.** 1982. Organization and replication of papovavirus DNA in: *Organization and Replication of Viral DNA* (Kaplan, A.S. ed.) CRC Press Boca Raton, Florida, 37-114.
  21. **deVilliers, J., L. Olson, C. Tyndall, and W. Schaffner.** 1982. Transcriptional enhancers from SV40 and polyoma virus show a cell type preference. *Nucleic Acids Res.* **10**:7965-7976.
  22. **deVilliers, J., and W. Schaffner.** 1981. A small segment of polyoma virus DNA enhances the expression of a cloned  $\beta$ -globin gene over a distance of 1,400 base pairs. *Nucleic Acids Res.* **9**:6251-6264.
  23. **deVilliers, J., W. Schaffner, C. Tyndall, S. Lupton, and R. Kamen.** 1984. Polyoma virus DNA replication requires an enhancer. *Nature (London)* **312**:242-246.
  24. **Dilworth, S. M., A. Cowie, R. I. Kamen, and B. E. Griffin.** 1984. DNA binding activity of polyoma virus large tumor antigen. *Proc. Natl. Acad. Sci. USA* **81**:1941-1945.
  25. **Dubensky, T. W., F. A. Murphy, and L. P. Villarreal.** 1984. Detection of DNA and RNA virus genomes in organ systems of whole mice: patterns of mouse organ infection by polyoma virus. *J. Virol.* **50**:779-783.
  26. **Fangman, W. L., R. H. Hice, and E. Chlebowicz-Sledziwska.** 1983. ARS replication during the yeast S phase. *Cell* **32**:831-838.
  27. **Flach, G., M. H. Johnson, P. R. Braude, R. A. S. Taylor, and V. N. Bolton.** 1982. The transition from maternal to embryonic control in the 2-cell mouse embryo. *EMBO J.* **1**:681-686.
  28. **Forbes, D. J., M. W. Kirschner, and J. W. Newport.** 1983. Spontaneous formation of nucleous-like structures around bacteriophage DNA microinjected into *Xenopus* eggs. *Cell* **34**:13-23.
  29. **Fujimura, F. K., P. L. Deininger, T. Friedmann, and E. Linney.** 1981. Mutation near the polyoma DNA replication origin permits productive infection of F9 embryonal carcinoma cells. *Cell* **23**:809-814.
  30. **Fujimura, F. K., and E. Linney.** 1982. Polyoma mutants that productively infect F9 embryonal carcinoma cells do not rescue wild-type polyoma in F9 cells. *Proc. Natl. Acad. Sci. USA* **79**:1479-1483.
  31. **Fujimura, F. K., P. E. Silbert, W. Eckhart, and E. Linney.** 1981. Polyoma virus infection of retinoic acid-induced differentiated teratocarcinoma cells. *J. Virol.* **39**:306-312.
  32. **Gargiulo, G., F. Razvi, and A. Worcel.** 1984. Assembly of transcriptionally active chromatin in *Xenopus* oocytes requires specific DNA binding factors. *Cell* **38**:511-521.
  33. **Graessmann, M., and A. Graessmann.** 1976. Early simian-virus-40-specific RNA contains information for tumor antigen formation and chromatin replication. *Proc. Natl. Acad. Sci. USA* **73**:366-370.
  34. **Harland, R. M., and R. A. Laskey.** 1980. Regulated replication of DNA microinjected into eggs of *Xenopus laevis*. *Cell* **21**:761-771.
  35. **Hay, R. T., E. A. Hendrickson, and M. L. DePamphilis.** 1984. Sequence specificity for the initiation of RNA-primed simian virus 40 DNA synthesis *in vivo*. *J. Mol. Biol.* **175**:131-157.
  36. **Heintz, N. H., J. D. Milbrant, K. S. Geisen, and J. L. Hamlin.** 1983. Cloning of the initiation region of a mammalian chromosomal replicon. *Nature (London)* **302**:439-441.
  37. **Herbomel, P., B. Bourachot, and M. Yaniv.** 1984. Two distinct enhancers with different cell specificities coexist in the regulatory region of polyoma. *Cell* **39**:653-662.
  38. **Herbomel, P., S. Saragosti, D. Blangy, and M. Yaniv.** 1981. Fine structure of the origin-proximal DNase I-hypersensitive region in wild-type and EC mutant polyoma. *Cell* **25**:651-658.
  39. **Hines, P. J., and R. M. Benbow.** 1982. Initiation of replication at specific origins in DNA molecules microinjected into unfertilized eggs of the frog *Xenopus laevis*. *Cell* **30**:459-468.
  40. **Hirt, B.** 1967. Selective extraction of polyoma DNA from infected mouse cell cultures. *J. Mol. Biol.* **26**:365-369.
  41. **Jat, P., U. Novak, A. Cowie, C. Tyndall, and R. Kamen.** 1982. DNA sequences required for specific and efficient initiation of transcription at the early promoter. *Mol. Cell. Biol.* **2**:737-751.
  42. **Johnson, M. H.** 1981. The molecular and cellular basis of preimplantation mouse development. *Biol. Rev.* **56**:463-498.
  43. **Katinka, M., and M. Yaniv.** 1983. DNA replication origin of polyoma virus: early proximal boundary. *J. Virol.* **47**:244-248.
  44. **Kelly, F., and H. Condamine.** 1982. Tumor viruses and early mouse embryos. *Biochim. Biophys. Acta Rev. Cancer* **651**:106-141.
  45. **Lacks, S., and B. Greenberg.** 1977. Complementary specificity of restriction endonucleases of *Diplococcus pneumoniae* with respect to DNA methylation. *J. Mol. Biol.* **114**:153-168.
  46. **Laskey, R. A.** 1980. The use of intensifying screens or organic scintillators for visualizing radioactive molecules resolved by gel electrophoresis. *Methods Enzymol.* **65**:363-371.
  47. **Laskey, R. A., A. D. Mills, and N. R. Morris.** 1977. Assembly of SV40 chromatin in a cell-free system from *Xenopus* eggs. *Cell* **10**:237-243.
  48. **Linney, E., and S. Donerly.** 1983. DNA fragments from F9 PyEC mutants increase expression of heterogeneous genes in transfected F9 cells. *Cell* **35**:693-699.
  49. **Lusky, M., and M. Botchan.** 1981. Inhibition of SV40 replication in simian cells by specific pBR322 DNA sequences. *Nature (London)* **293**:79-81.
  50. **Luthardt, F. W., and R. P. Donahue.** 1973. Pronuclear DNA synthesis in mouse eggs. *Exp. Cell Res.* **82**:143-151.
  51. **Luthman, H., M.-G. Nilsson, and G. Magnusson.** 1982. Non-contiguous segments of the polyoma genome required in cis for DNA replication. *J. Mol. Biol.* **161**:533-550.
  52. **Maniatis, T., E. F. Fritsch, and J. Sambrook.** 1982. Molecular cloning: a laboratory manual. Cold Spring Harbor Laboratory, Cold Spring Harbor, N.Y.
  53. **Mariani, B. D., and R. T. Schimke.** 1984. Gene amplification in a single cell cycle in Chinese hamster ovary cells. *J. Biol. Chem.* **259**:1901-1910.
  54. **Martin, G. R.** 1980. Teratocarcinoma and mammalian embryogenesis. *Science* **209**:768-776.
  55. **McCutchan, J. H., and J. S. Pagano.** 1968. Enhancement of the infectivity of simian virus 40 deoxyribonucleic acid with diethylaminoethyl-dextran. *J. Natl. Cancer Inst.* **41**:351-356.
  56. **McKnight, S. L., and O. L. Miller, Jr.** 1977. Electron microscopic analysis of chromatin replication in the cellular blastoderm *Drosophila melanogaster* embryo. *Cell* **12**:795-804.
  57. **McTiernan, C. F., and P. J. Stambrook.** 1984. Initiation of SV40 DNA replication after microinjection into *Xenopus* eggs. *Biochim. Biophys. Acta* **782**:295-303.
  58. **Mechali, M., and S. Kearsley.** 1984. Lack of specific sequence requirement for DNA replication in *Xenopus* eggs compared with high sequence specificity in yeast. *Cell* **38**:55-64.
  59. **Miller, T. J., and J. E. Mertz.** 1982. Template structural requirements for transcription *in vivo* by RNA polymerase II. *Mol. Cell. Biol.* **2**:1595-1601.
  60. **Mueller, C. R., A.-M. Mes-Masson, M. Bouvier, and J. A. Hassell.** 1984. Location of sequences in polyomavirus DNA that are required for early gene expression *in vivo* and *in vitro*. *Mol. Cell. Biol.* **4**:2594-2609.
  61. **Muggleton-Harris, A., D. G. Whittingham, and L. Wilson.** 1982. Cytoplasmic control of preimplantation development *in vitro* in the mouse. *Nature (London)* **299**:460-462.
  62. **Muller, W. J., C. R. Mueller, A.-M. Mes, and J. A. Hassell.** 1983. Polyomavirus origin for DNA replication comprises multiple genetic elements. *J. Virol.* **47**:586-599.
  63. **Newport, J., and M. Kirschner.** 1982. A major developmental transition in early *Xenopus* embryos. I. characterization and timing of cellular changes at the midblastula stage. *Cell* **30**:675-686.
  64. **Newport, J., and M. Kirschner.** 1982. A major developmental transition in early *Xenopus* embryos. II. control of the onset of transcription. *Cell* **30**:687-696.
  65. **Osheim, Y. N., and O. L. Miller, Jr.** 1983. Novel amplification and transcriptional activity of chorion genes in *Drosophila melanogaster* follicle cells. *Cell* **33**:543-553.
  66. **Peden, K. W. C., J. M. Pipas, S. Pearson-White, and D. Nathans.**

1980. Isolation of mutants of an animal virus in bacteria. *Science* **209**:1392-1396.
67. Pomerantz, B. J., C. R. Mueller, and J. A. Hassell. 1983. Polyomavirus large T-antigen binds independently to multiple, unique regions on the viral genome. *J. Virol.* **47**:600-610.
68. Rigby, P. W. J., M. Dieckmann, C. Rhodes, and P. Berg. 1977. Labeling deoxyribonucleic acid to high specific activity *in vitro* by nick translation with DNA polymerase I. *J. Mol. Biol.* **113**:237-251.
69. Rothwell, V. M., and W. R. Folk. 1983. Comparison of the DNA sequence of the Crawford small plaque variant of polyomavirus with those of polyomaviruses A2 and strain 3. *J. Virol.* **48**:472-480.
70. Sawicki, W., J. Abramczuk, and O. Blaton. 1978. DNA synthesis in the second and third cell cycles of mouse preimplantation development. *Exp. Cell Rés.* **112**:199-205.
71. Segal, S., A. J. Levine, and G. Khoury. 1978. Evidence for non-spliced SV40 RNA in undifferentiated murine teratocarcinoma stem cells. *Nature (London)* **280**:335-337.
72. Sekikawa, K., and A. J. Levine. 1981. Isolation and characterization of polyoma host range mutants that replicate in nullipotent embryonal carcinoma cells. *Proc. Natl. Acad. Sci. USA* **78**:1100-1104.
73. Southern, E. 1975. Detection of specific sequences among DNA fragments separated by gel electrophoresis. *J. Mol. Biol.* **98**:503-512.
74. Stark, G. R., and G. M. Wahl. 1984. Gene amplification. *Annu. Rev. Biochem.* **53**:447-491.
75. Stern, S., and P. M. Wassarman. 1974. Meiotic maturation of the mammalian oocyte *in vitro*: effect of dibutyryl cyclic AMP on protein synthesis. *J. Exp. Zool.* **189**:275-281.
76. Struhl, K. 1983. The new yeast genetics. *Nature (London)* **305**:391-396.
77. Swartzendruber, D. E., and J. M. Lehman. 1975. Neoplastic differentiation: interaction of simian virus 40 and polyoma virus with murine teratocarcinoma cells *in vitro*. *J. Cell. Physiol.* **85**:179-188.
78. Tapper, D. P., and M. L. DePamphilis. 1978. Discontinuous DNA replication: accumulation of SV40 DNA at specific stages in its replication. *J. Mol. Biol.* **120**:401-422.
79. Tyndall, C., G. LaMantia, C. M. Thacker, J. Favalaro, and R. Kamen. 1981. A region of the polyoma virus genome between the replication origin and late protein coding sequences is required in cis for both early gene expression and viral DNA replication. *Nucleic Acids Res.* **9**:6231-6250.
80. Vasseur, M., M. Katinka, P. Herbomel, M. Yaniv, and D. Blangy. 1982. Physical and biological features of polyoma virus mutants able to infect embryonal carcinoma cell lines. *J. Virol.* **43**:800-808.
81. Wahl, G. M., M. Stern, and G. R. Stark. 1979. Efficient transfer of large DNA fragments from agarose gels to diazobenzoxymethyl-paper and rapid hybridization by using dextran sulfate. *Proc. Natl. Acad. Sci. USA* **76**:3683-3688.
82. Wassarman, P. M., and W. J. Josefowicz. 1978. Oocyte development in the mouse: an ultrastructural comparison of oocytes isolated at various stages of growth and meiotic competence. *J. Morphol.* **156**:209-235.
83. Whitten, W. K., and J. D. Biggers. 1968. Complete development *in vitro* of the pre-implantation stages of the mouse in a simple chemically defined medium. *J. Reprod. Fert.* **17**:399-401.
84. Wyllie, A. H., R. A. Laskey, J. Finch, and J. B. Gurdon. 1978. Selective DNA conservation and chromatin assembly after injection of SV40 into *Xenopus* oocytes. *Dev. Biol.* **64**:178-188.
85. Zakian, V. A. 1976. Electron microscopic analysis of DNA replication in main band and satellite DNAs of *Drosophila virilis*. *J. Mol. Biol.* **108**:305-331.