

Bacteriophage Lysis: Mechanism and Regulation

RY YOUNG

Department of Biochemistry and Biophysics, Texas A&M University, College Station, Texas 77843

INTRODUCTION	431
LYSIS BY LAMBDOID PHAGES	433
Physiology and Premature Lysis	433
Late Gene Expression and Lysis Genes	433
Gene S: Structure and Phenotype	435
S Gene Products	436
Genetic Analysis of S and Discovery of the Dual-Start Motif	437
Evidence for the Dual-Start Model	437
Phage 21 Lysis Genes: a New Kind of S Gene	438
S ²¹ : Conservation of the Dual-Start Motif.....	439
Analysis of Primary Sequence and Topology Predictions.....	439
Mutational Analysis	440
Imagining the S-Dependent Hole	443
Probing S In Vivo	443
How Does the Inhibitor Work?	444
Regulation of S Expression	444
Other Models for λ Lysis.....	444
Current Questions and Perspectives	445
BACTERIOPHAGE T4	446
Overview.....	446
Lysis and Lysis Inhibition	446
Genes and Molecular Mechanisms	447
<i>r</i> and <i>rex</i> Genes	448
Model for Lysis Inhibition.....	448
Lysis from Without	449
Phospholipase Activity.....	450
Star Mutants.....	450
LYSOZYME-INDEPENDENT LYSIS SYSTEMS: ϕ X174 AND MS2	450
Host Autolysis and Liberation of Bacteriophage.....	450
BACTERIOPHAGE ϕ X174	451
Overview.....	451
ϕ X174 Lysis Physiology.....	451
<i>E</i> Gene Structure	452
Identification of the E Protein	454
Lysis by Including the Cloned <i>E</i> Gene	454
Regulation of <i>E</i> Expression	455
Host Genes Involved in <i>E</i> Function	455
Molecular Mechanism and <i>E</i> -Holes	456
Phage λ with ϕ X174 Lysis	457
Perspective	458
RNA PHAGE LYSIS GENES	458
Lysis Physiology of RNA Phage.....	458
Lysis Gene <i>L</i> of Group I RNA Phage	458
Regulation of <i>L</i> Synthesis.....	459
<i>L</i> Protein: Structure and Function	461
In Vitro Lysis System for <i>L</i>	462
Perspective and Model	464
Group III RNA Phage.....	464
BACTERIOPHAGE T7	464
A Lysozyme Discredited	464
Identification of a Lysis Gene.....	465
Lysozyme Redux	465
Parallels with λ and T4?.....	466
OTHER PHAGE LYSIS SYSTEMS	466
Mu.....	466
P1.....	466
P2 and Relations	467

Lipid-Containing Phage.....	467
Lysis in Phage Infections of Gram-Positive Hosts	468
Perspectives	472
HOLIN FAMILY	472
WHY TWO STRATEGIES?.....	473
HORIZONS IN THE STUDY OF LYSIS SYSTEMS	473
ACKNOWLEDGMENTS.....	474
REFERENCES	474

INTRODUCTION

Picture a sweltering attic laboratory at the Pasteur Institute on a summer day in 1949. André Lwoff has just irradiated a culture of a *Bacillus megaterium* lysogen and collapsed in an armchair, "in sweat, despair, and hope." For the next hour, Lwoff's technician, consumed with the experiment to the point of identifying with its principal protagonist, watches the bacteria through a microscope and repeatedly reports, "Sir, I am growing normally." Then, suddenly, comes the exciting announcement, "Sir, I am entirely lysed." Lwoff cites this event as the greatest thrill of his scientific career (197).

Having studied the phenomenon of phage-induced lysis for years, I empathize with Lwoff's excitement. Clearly, to Lwoff and others, lysis per se was primarily a "reporter" event and thus of secondary interest with respect to the question of the relationship between prophage and virion production. Still, phage lysis, with its saltatory and macroscopic character, is uniquely arresting among the phenomena that we can actually watch in microbiology. It is strange, then, to find it largely overlooked as a problem for experimentation. To many, the problem is regarded as solved, with only details remaining to be worked out. For instance, it is commonly accepted that bacteriophage lysis is the inevitable result of the accumulation of phage-encoded lysozyme during late protein synthesis. To cite one of the most popular general texts on molecular biology: "To solve this problem [of how to achieve progeny release], many phages have a gene that codes for the amino acid sequence of lysozyme, a cell wall-destroying enzyme. This enzyme begins to be synthesized when the coat proteins appear and causes the rupture of the cell wall at about the time virus maturation is complete" (303). So it is usually a surprise to hear that for many phages, such as ϕ X174 and MS2, no lysozyme is elaborated, and in others, such as λ , T4, and probably T7, the accumulation of lysozyme activity is irrelevant to the actual scheduling of lysis. That these misconceptions are so widespread is largely because the elegant physiology and genetics defining phage biology, and phage lysis in particular, predate the molecular era. So, although lysis is a relatively simple event associated with phage genetic systems of immense power and, as we shall see, the implementation and regulation of lysis involve important phenomena such as protein-membrane interactions, membrane energetics, and translational control, very little has been done. To my knowledge, this review is the first completely dedicated to phage lysis, more than 50 years after Delbrück's paper, "The growth of bacteriophage and lysis of the host," appeared in the *Journal of General Physiology* (79). The reader, however, is specifically referred to two recent works which are relevant: a review by Dabora and Cooney (72) which deals with cellular autolysins and phage lysis systems, mostly from the perspective of practical utility for disruption of cells, and a review by Witte et al. (310) focused on the lytic function of the ϕ X174 gene *E*.

I can think of several factors which have probably contributed to the slow progress. Technically, the isolation and study of phage lysis genes was and is a tricky business, even with modern technology. These are genes designed to kill bacteria, usually at low expression levels, and so cloning of such genes on multicopy plasmids requires careful attention to negative regulation. The proteins involved, other than lysozymes, have been refractory to purification, partly because one cannot just overproduce them (because all you get is quick cell death!) and partly because the proteins are usually very small, membrane embedded, and without enzymatic activity. There is also the difficulty that, with the notable exception of the L protein of MS2 (see below), no system has been worked out for modeling lysis in vitro. Probably many individuals initially interested in the problem have looked down the road and not perceived any reasonable way to do meaningful molecular biology and biochemistry. Finally, there is a general misapprehension of what phage-induced lysis is. There are many ways that cells can lyse, but only a few are specifically and directly caused by phage-encoded lysis functions within a period consistent with the developmental program of the phage. Thus, specific phage-induced cell lysis must be clearly distinguished from the cellular dissolution which is the eventual consequence of physiologic death (for all cells!).

In this review, I will focus on phage genes which have specifically evolved for terminating the vegetative cycle by lysing the cell. Usually, this role confers upon a lysis gene the singular characteristic of being essential for plaque formation but not for accumulation of infective phage. This predicted characteristic has been used to enrich for mutations in the true lysis genes of several phages, most notably λ and T4. However, it should be noted that such a strategy requires that the lysis gene not have a pleiotropic role in phage production, as in the case of the T7 lysozyme gene (see below).

Historically, the experiment used to characterize phage lysis involves inducing a lysogen or infecting a sensitive culture as synchronously as possible and then observing the lysis profile (Fig. 1), which is simply the path of the turbidity, usually measured as Klett units or A_{550} . Measurement of turbidity is an incomplete characterization of lysis, because the loss of turbidity may arise from fundamentally different lytic events at the cellular level. The two extreme cases are total cellular destruction, leaving featureless debris (Fig. 2A), as in the case of the double-stranded DNA phage λ , or simple cellular emptying, leaving nonrefractile but rod-shaped ghosts, as in the case of the lysis caused by overexpression of the *E* gene of the single-stranded circular DNA phage ϕ X174 (Fig. 2B). In the former case, the total destruction appears to be due to a phage-encoded protein traditionally called an endolysin or lysin. Endolysins can be any one of several unrelated types of enzyme (i.e., lysozyme, amidase, or transglycosylase), which attack either the glycosidic bonds (i.e., lysozymes and transglycosylases) or peptide bonds (i.e., amidases) that, in aggregate, confer mechanical

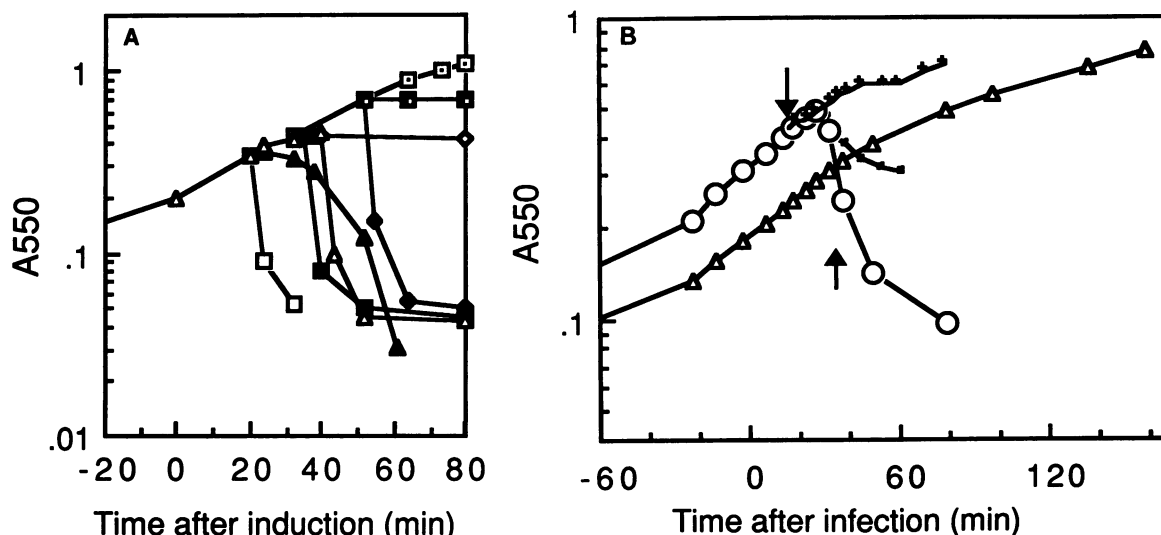

FIG. 1. Lysis profiles for bacteriophages λ and ϕ X174. The A_{550} of broth cultures, determined by using a Gilford Stasar II Spectrophotometer with a sipping attachment, is plotted versus time after induction or infection. In cases when a supplement is added, A_{550} values are corrected for the consequent small dilutions. (A) Induction of a λ lysogen. A standard *E. coli* K-12 lysogen, MC4100(λ cI857), is grown aerobically at 30°C until $A_{550} = 0.2$ (10^8 cells per ml), aerated at 42°C for 20 min beginning at $t = 0$, and then aerated at 37°C. The absolute time for the onset of rapid lysis, shown here as approximately 40 min, depends on the medium, degree of aeration, culture density, and particular host background and can range up to about 55 min. The profile for the λ cI857 lysogen is shown with normal induction (Δ), KCN added at 20 min (\blacktriangle) or 35 min (\blacksquare), and CHCl_3 added at 20 min (\square) (which is identical to the profile for an isogenic lysogen carrying the early lyser S_{A52G} allele). Also shown are profiles for a λ R⁻ lysogen (\diamond), a λ Sam7 lysogen induced but otherwise untreated (\square), and a λ Sam7 lysogen induced and treated at 50 min with KCN (\blacksquare) or CHCl_3 (\blacklozenge). In all cases, KCN is added to a final concentration of 10 mM. (B) Infection with ϕ X174. The prototrophic, nonsuppressing *E. coli* C strain 990 was grown in LB broth supplemented with 2 mM CaCl_2 and infected with ϕ X174 at a nominal multiplicity of 5 at $t = 0$, and its lysis profile was monitored (\circ). Portions of the infected culture were supplemented with 0.2 M MgSO_4 (\downarrow) at 15 min (+) or 10 mM KCN (\uparrow) at 30 min (\times). Also shown is an isogenic C990 *shyD* subjected to an identical infection (Δ).

rigidity on the peptidoglycan (see Fig. 4). This degradation continues even after the progeny phage are liberated. In the cell-emptying case, no phage-induced endolysin activity can be detected, yet cell wall lesions of a size sufficient to allow release of the cytoplasmic contents are formed (49, 50, 310).

There is at least some molecular information about these two distinctly different lysis systems (λ and ϕ X174) and also about the single-stranded RNA male-specific phage MS2, which appears to share features of the ϕ X174 system. I shall

review these three systems in detail to establish some prototypes. Despite a nearly complete absence of molecular data, a significant space will also be devoted to the phage T4 lysis system in the hope that, from the perspective of the 1990s, the data of previous decades can be reinterpreted and extrapolated to a working model of this system, in which phage lysis was first subjected to detailed study (79). Finally, the little that is known about other phage lysis systems will be briefly examined. A differing mix of physiology and

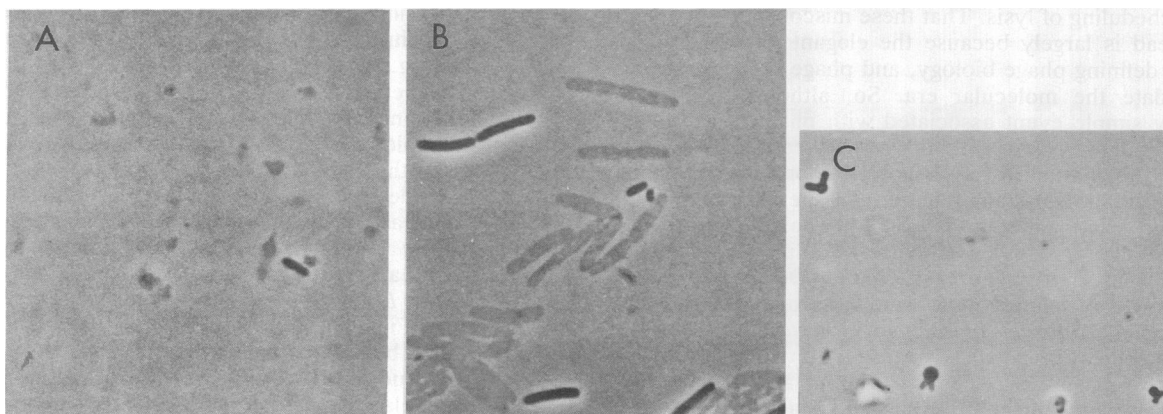

FIG. 2. Morphology of lysis products. Micrographs are shown enlarged identically from 400 \times phase-contrast fields. Unlysed cells are included for comparison. (A) Debris from the thermally induced MC4100(λ cI857) lysogen shown in Fig. 1A. (B) Debris from induction of cells carrying the ϕ X174 *E* gene under multicopy *lacP* control. (C) C990 culture infected with ϕ X174, at approximately 25 min after infection.

genetics is available for each system, so there will not be a standard format. In all cases, one fundamental question is the nature of the disruption event. Observance of Occam's razor requires determining whether there is resemblance to one of the well-characterized systems (i.e., lysozyme-dependent destruction of the cell wall, as with λ or T4, or lysozyme-independent disruption of the envelope, as effected by ϕ X174 and MS2). Another critical concern is the regulation of the lytic phenomenon. It is not sufficient to identify the genes required for lysis; we must also try to discern how lysis is implemented at the right time. It is important to note that a lysis gene can be nonfunctional either by failing to cause lysis or by causing lysis too early in the vegetative cycle, before the progeny have assembled. In no case does this regulation involve transcriptional control, since defined late-gene expression periods always begin long before lysis occurs. As we shall see, such timing mechanisms operate both at the level of translation and at the level of the protein function, probably including environmental sensing. The reader is warned that the mechanistic descriptions are highly leveraged with respect to actual data, mostly because molecular approaches have only recently been applied and also, as mentioned above, because no completely satisfactory system has been established for reconstituting phage-induced lysis *in vitro*.

LYSIS BY LAMBDOID PHAGES

Physiology and Premature Lysis

The lysis of *Escherichia coli* by lambdoid phage has been studied extensively, beginning with the demonstration by Jacob and Fuerst (167) that λ lysates contain a protein designated endolysin that is capable of degrading peptidoglycan. λ is a temperate phage which forms inducible lysogens, and the existence of the *cl857* temperature-sensitive repressor allele makes it easy to induce vegetative growth synchronously in all the cells of a culture. For λ , an exponential increase in turbidity is observed for about 30 min after thermal induction of a temperature-sensitive (*ts*) lysogen, if care is taken to avoid nutrient or oxygen limitation. The lysis profile then enters an erratic phase for about 10 min before commencing an extremely rapid decrease at about 40 min (Fig. 1A). Under microscopic examination, the immediate prelysis events occurring during the erratic phase consist of a mixture of cellular morphologies, including the formation of oblong "shmoos" and highly unstable spheres with visibly decreasing refractility. The sudden drop in turbidity is associated with total dissolution of the cells. The turbidity remaining after lysis does not result from a significant subpopulation which escape destruction but rather from residual light scattering from cellular debris, which has, however, hardly any recognizable cellular features (Fig. 2A). λ lysis, which we define as normally scheduled for 40 min (including 20 min of aeration at 42°C for induction, followed by aeration at 37°C), can be induced early by the addition of energy poisons (58, 248). This has been called premature lysis; it is apparently the same event described much earlier by Heagy (135) and Doermann (83) for the T-even phages (see below). Energy poisons such as cyanide, dinitrophenol, and carbonyl cyanide *m*-chlorophenylhydrazone (CCCP) act essentially instantaneously to trigger lysis, from about 30 min after induction. Addition of such poisons earlier in induction either prevents lysis or has only a partial and delayed effect (Fig. 1A) (170, 248). In contrast, addition of CHCl_3 even as early as 20 min after induction causes

immediate and very rapid lysis, demonstrating that lysis is not limited by the activity of murein-degrading activity elaborated during the vegetative phase. These observations have been interpreted as demonstrating that premature lysis requires a certain minimal accumulation of a phage late gene product distinct from the phage murein hydrolase. Premature lysis can also be induced by protein synthesis inhibitors such as chloramphenicol, but the lytic event is not instantaneous as it is with the energy poisons, requiring a lag of 5 min or more (58). Since the ability to cause premature lysis implies a regulatory system for scheduling lysis, premature lysis has always been a central aspect of the phenomenon, one which any model of lysis regulation must address.

Late Gene Expression and Lysis Genes

In lambdoid phages, all late genes are transcribed from a single promoter, designated p_R , in λ (44, 77, 143). The promoter-proximal cistrons on the late transcript are the three lysis genes *S*, *R*, and *Rz* (Fig. 3A), after which are arrayed the genes required for capsid and tail formation (75). The 598 nucleotides (nt) between the 5' end of the mRNA (77) and the *SRRz* cluster contain no identifiable genes but feature several prominent domains strongly predicted to be involved in stem-loop secondary structures (Fig. 3B). This potentially complex secondary structure may be involved in the translational control of the lysis genes (see below). The late promoter is constitutive, but, in the absence of function of the delayed-early gene *Q*, transcripts from p_R are terminated, with an overall efficiency of 98%, primarily at the rho-independent terminator $t_{R'}$ (or t_{6S}) and also at the more distal rho-dependent terminator $t_{R'2}$ (196, 252, 276). *Q* encodes an antiterminator protein which requires a site called *gut* that is not separable from the p_R promoter (112). Normally, *Q*-dependent transcription of the late genes begins at about 8 to 10 min after induction of a lysogen or infection and continues until lysis (247). Note that the terminated transcript, known for historical reasons as the 6S RNA, is a prominent feature during immediate-early and early transcription and also in the uninduced lysogen (77, 277).

The *SRRz* gene cluster is neatly contained within an *EcoRI*-*Clal* fragment in λ (Fig. 3A), and so in our laboratory it is often called the lysis cassette, since efficient, inducible lysis can be obtained if the cluster is cloned under any regulatable promoter (41, 105). The *S* gene controls lysis and will be considered separately below. Its general function is to cause lesions in the cytoplasmic membrane through which the murein-degrading activity encoded by the *R* gene (57) can escape to the periplasm. The *R* gene in λ encodes a transglycosylase which, like canonical phage lysozymes, attacks the glycosidic linkages in the peptidoglycan but, unlike the lysozymes, generates a cyclic 1,6-disaccharide product (32) (Fig. 4). This distinction is irrelevant to the mechanism of lysis, since *R* defects can be complemented by the true lysozymes of either the *Salmonella* lambdoid phage P22 or the coliphage T4. (Technically, a transglycosylase is not a murein hydrolase, but for the purposes of this review, this distinction will be ignored.) The lysozymes are distantly related, with 26% identity (304), but they have no detectable sequence similarity with the predicted *R* product (250) (Fig. 5). If *R* is inactivated, lysis is abolished but the cells are physiologically dead, in the sense that respiration and macromolecular synthesis cease at the normal time of lysis (9, 106, 248) (Fig. 1A). *R* protein is soluble, has a sodium dodecyl sulfate-polyacrylamide gel electrophoresis (SDS-

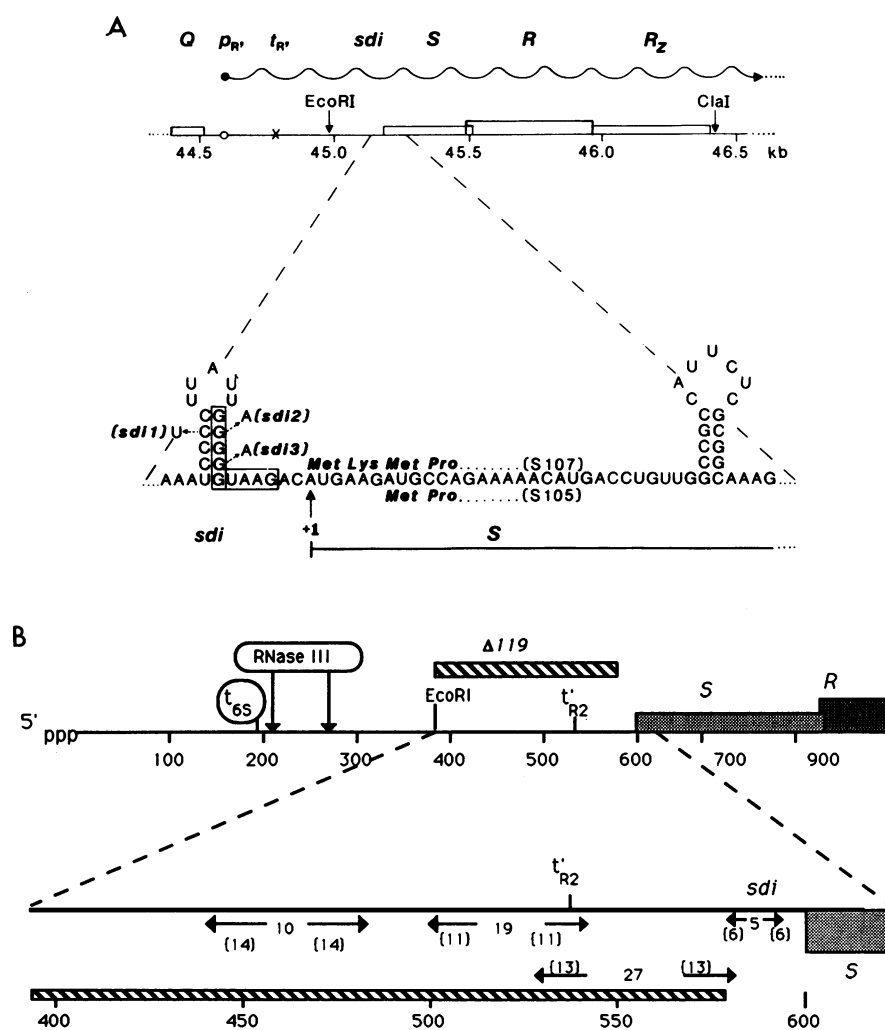

FIG. 3. Map of the λ lysis gene region. (A) Translational initiation region of *S*. The promoter-proximal genes of the late operon of λ are shown. The nucleotide coordinates, numbering from the left end of the λ genome, are taken from reference 76. The wavy line indicates the 5' end of the late transcript. Symbols: \circ , late promoter; \times , major late terminator. *EcoRI* and *ClaI* sites which defined the lysis cassette are indicated. The translational initiation region of *S* is shown in the blow-up, with nucleotides numbered from the first base of the Met-1 AUG codon. Also shown are the upstream and intragenic stem-loop structures which define the *sdi* regulatory region, the three original *sdi* mutations isolated as partially dominant S^- alleles (244), and the reading frames for S107 and S105. Reprinted from reference 41 with permission. (B) Structural features of the 5' untranslated region of the λ late mRNA. Numbering is in nucleotides from the 5' end of the late mRNA, as determined by Daniels et al. (77). The major terminator (t_{6S}), minor terminator (t_{R2}'), and RNase III sites are shown, as well as the extent of the $\Delta 119$ deletion (hatched bars), which removes the sequences between the *EcoRI* site and the first base of the *sdi* stem loop structure (see panel A). The large potential hairpin loops upstream of *S* are indicated by pairs of arrows flanking the number of unpaired bases, with the predicted stem length superimposed in brackets.

PAGE) mobility consistent with its predicted 158-residue primary structure, and, in the absence of *S* function, accumulates intracellularly in its fully active, unprocessed form (163). Like the T4 gene *e* and P22 gene *19* lysozymes, the transglycosylase has no secretory signal sequence and thus is incapable of reaching the periplasm without the function of a membrane-permeabilizing gene. The *R* genes of phages 21 and PA-2 are nearly identical and have 32% sequence identity with gene *19* (Fig. 5), indicating that these two genes also encode true lysozymes, although neither gene product has yet been identified or explicitly characterized as to enzymatic function (47).

Of the three genes, *Rz* is the most recently discovered and most strongly conserved among the four lambdoid phages (λ ,

P22, 21, and PA-2) for which the lysis cassette has been sequenced (Fig. 5). Its function is unknown. If *Rz* is inactivated, lysis in broth culture is unaffected unless 5 to 10 mM divalent cations are present, in which case spherical cells are formed at the normal lysis time (61, 323). These spherical cells are mechanically fragile and gradually lose cytoplasmic contents (323). An endopeptidase activity detected in λ lysates and originally ascribed to *R* (287) may in fact reflect *Rz* function. If so, the role of the *Rz* protein may be to cleave the oligopeptide cross-links in the peptidoglycan and/or between the peptidoglycan and the outer membrane (Fig. 4). The spherical cell phenotype would thus be the result of divalent-cation stabilization of the outer membrane and consequent partial retention of the mechanical strength of

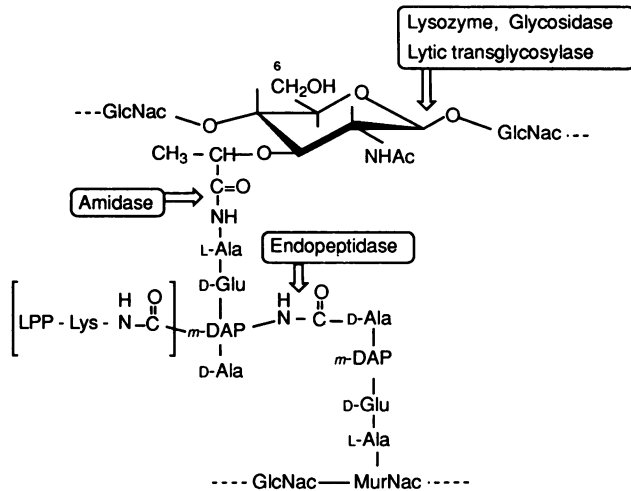

FIG. 4. Points of attack of phage-encoded and autolytic murein-degrading enzymes. A segment of the peptidoglycan is shown. The glycan moiety consists of alternating residues of *N*-acetylmuramic acid (MurNac) and *N*-acetylglucosamine (GlcNac) linked by $\beta(1\rightarrow4)$ glycosidic bonds. The glycan strands are decorated with a tetrapeptide, linked by an amide bond formed between the carboxyl group of the *O*-lactyl group of each MurNac residue. The tetrapeptide, consisting of L-alanine, D-glutamate, *meso*-diaminopimelate (*m*-DAP), and D-alanine, is sometimes (50% or less in *E. coli*) cross-linked to the tetrapeptide of another glycan strand. This linkage occurs via a peptide bond formed between the ω amino group of diaminopimelate on one tetrapeptide and the carboxyl group of the C-terminal D-alanine of another tetrapeptide. About 10% of the tetrapeptides are linked to lipoprotein (LPP), a major outer membrane protein species, by a peptide bond formed between the ϵ -amino group of a lysine residue in the lipoprotein and the free carboxyl group of diaminopimelate (235). Phage-encoded enzymes which degrade the murein include true lysozyme (glycosidase) and transglycosylase activities. True lysozyme or glycosidase encoded by the T4 *e* gene and related genes hydrolyzes the $\beta(1\rightarrow4)$ glycosidic bond. The λ *R* gene product encodes a transglycosylase, which breaks the glycan chain by cleaving the glycosidic bond and then catalyzing the intramolecular transfer of the *O*-muramyl residue to its own C-6 hydroxyl group (designated by the small number 6). An endopeptidase activity elaborated in λ infections has also been detected and is thought to cleave the cross-linking peptide bond (287); it may be encoded by the *Rz* gene and related genes (32, 323). The major *E. coli* autolysins include the lytic transglycosylases encoded by *slt* and *mlt*, the *amiA* amidase, and the *dacB* and *mepA* DD-endopeptidases (148) (see the text).

the peptidoglycan, despite the extensive loss of glycosidic linkages. *Rz* is a membrane protein and possesses an N-terminal sequence strongly resembling a secretory signal sequence; however, *in vivo*, the *Rz* protein has an SDS-PAGE mobility slightly lower than that of *R* (63). This indicates that if signal peptide cleavage is occurring, the mature *Rz* product would have to have an anomalous SDS-PAGE mobility.

Gene S: Structure and Phenotype

The λ *S* gene spans 107 codons and is 89% identical to the 108-codon gene *I3* of P22 (Fig. 5). Related genes can be found by high-stringency hybridization to DNA fragments from the late gene regions of the lambdoid phages 80, 82, and 434 (47). Preliminary sequence data from the *S* gene of HK022 indicate a high degree of sequence similarity with λ *S* (115). Inactivation of *S* results in a distinctive phenotype in which respiration and macromolecular synthesis continue

unabated past the normal lysis time (Fig. 1A) (9, 106, 248). As a result, virions and endolysin activity accumulate intracellularly to very high levels, apparently limited only by available nutrients (106, 111, 128, 226, 248). Adding CHCl_3 to an induced λ *S*⁻ *R*⁺ lysogen results in almost instantaneous lysis, which suggests that the normal role of *S* is to permeabilize the cytoplasmic membrane (18, 106, 248). Moreover, premature lysis is not induced by energy poisons in the absence of *S* function, suggesting that deenergization of the membrane triggers *S* to function (58, 106, 248). The *S*-mediated lesions are lethal, and, in fact, expression of the *S* gene cloned under heterologous promoters results in loss of culture viability with kinetics independent of the allelic state of *R* or *Rz* (106). Under *S*⁺ *R*⁻ conditions, no lysis occurs but respiration and macromolecular synthesis stop at the normal lysis time (9, 106, 248). Thus the lethal event in lambdoid lysis is not lysis per se but the formation of the lesions in the cytoplasmic membrane which are required for access of endolysin to the peptidoglycan (248).

The *S*-dependent lesions have been characterized by indirect methods. If *S* has been induced to exert its lethal effect in the absence of endolysin activity, either in the context of the phage or from a plasmid-borne inducible promoter, the cells and membrane vesicles prepared from the cells have properties consistent with the notion that the inner membrane has aqueous holes in it: active transport is inactivated, nucleotides are released into the medium, and sucrose plasmolysis is no longer supported (106, 248, 307). Wilson found that spheroplasts formed from cells which had been killed by induction of a λ *S*⁺ *R*⁻ prophage could not be stabilized by low-molecular-weight osmolytes. Moreover, a 10% solution of polyethylene glycol could stabilize the spheroplasts if the average molecular weight of the polyethylene glycol was 20,000 but not if it was 10,000 (307). This finding is consistent with the existence of a transmembrane lesion or hole of approximately the right size to permit the free diffusion of endolysin molecules. (I have chosen the term "hole" for this lesion, rather than "pore," since "pore" is associated with a very different and much better-defined structure in the outer membrane.) Gross alteration of the membrane is not observed in electron micrographs of thin sections (63, 248). The failure to observe these holes may be due to the small number formed (see below). Ono and Ohnishi reported that *S* action allowed penetration of periplasmic RNase I activity into the cytoplasm, leading to the degradation of rRNA (231). There is detectable phospholipid hydrolysis, but this appears to be an effect of *S* action, rather than part of the mechanism, since inhibiting phospholipase activity by mutation or chemical agent has no effect on *S* function and the same level of phospholipase activity can be induced by mechanical or chemical insult to the membrane (248). With this indirect evidence in mind, I propose to designate *S* as a "holin," a term which for the rest of this review will be used for proteins performing the functionally homologous roles in other phage systems. This designation does not imply any particular model for the structure of the *S*-dependent holes. The holins and presumptive holins of a number of other phages, with both gram-negative and gram-positive hosts, have no detectable sequence similarity but have similar sizes and apparent domain structures (see Fig. 8). At the end of the review, I will return to consider the significance of the existence of this class of proteins and of the conserved structural features.

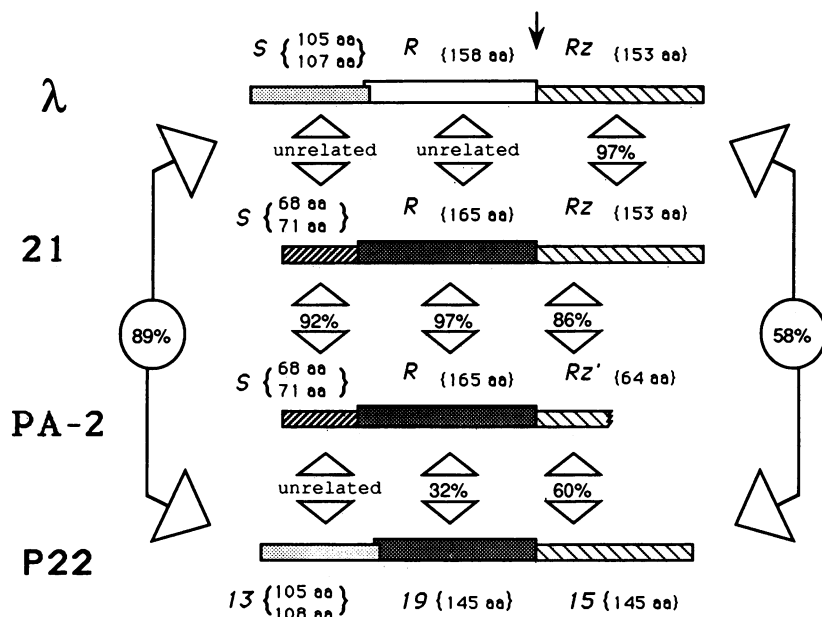

FIG. 5. Sequence similarities in four lambdoid lysis cassettes. The lysis cassettes of the lambdoid phages λ , 21, PA-2, and P22 are represented, aligned at the start site of the *Rz* gene (vertical arrow). Sequence similarities between pairs of genes are shown as percentages, using the predicted amino acid sequences for comparison (33, 47, 61, 76, 250). The outside bracket-arrows indicate the similarities between the *S*/13 and *Rz*/15 gene pairs. There is no detectable similarity between λ *R* and P22 19. Only a portion of the PA-2 *Rz* sequence is known. The brackets adjacent to each gene name contain the size of the predicted gene products in amino acid (aa) residues.

S Gene Products

The *S* gene spans 107 codons, and its predicted product would have a mass in excess of 11.6 kDa (see Fig. 8A). Of the products of essential genes in lambda, *S* was one of the last to be identified (10). However, it has made up for this late start by having no less than six different polypeptide species reported since 1980. As I review these reports, the reader should keep in mind the many problems associated with detecting a small, low-abundance, lethal, and relatively nonimmunogenic protein such as *S*. It was not until Zagotta and Wilson (324) were able to raise antibodies against *S*- β -galactosidase fusion proteins that this welter of *S* product claims could be sorted out. (Even so, as will be discussed below, this polyclonal antibody, and others like it, failed to react with one of the *S* products!) The first identification of *S* was as a low-abundance polypeptide of M_r 8,500 (8.5K polypeptide), present in [35 S]methionine-labeled proteins from the late phase of λ S^+ , but not λ *Sam7*, infections of UV-irradiated cells (10). The existence of this species was confirmed by maxicell labeling in vivo and by in vitro translation experiments (10, 35). This material is found only in the inner membrane, as judged by sucrose density gradient analysis, and has been confirmed as an *S* product by Western immunoblot and immunoprecipitation experiments (11, 63, 324). Small amounts of this form of *S* have been purified from the membranes of *S*-killed cells by immunofluorescence chromatography and shown to form SDS-resistant oligomers in vitro (324). It is not known whether the 8,500 M_r reflects abnormal SDS-PAGE mobility or processing of the 11.5K product predicted from the DNA sequence. Calculations based on the yield of the purified *S* from this procedure and other methods indicate that only 10^2 to 10^3 molecules are present when the lethal hole formation occurs (324). This not only puts constraints on models for how the formation of these holes is regulated but also causes great difficulty in

obtaining biochemically useful quantities of pure *S* protein from infected cells.

Another form of *S* protein, an acidic 17.5K product arising near the end of the vegetative cycle, was identified by comparing proteins from induced S^+ and S^- lysogens on two-dimensional gels (307). This 17.5K species is unlikely to be an SDS-resistant dimer of *S* since the reported isoelectric point would require extensive covalent modification of the primary product, which should be a strongly basic polypeptide. Its existence was not confirmed by immunological methods, and so it is probably not an *S* product (324). Probably the most intriguing report of an *S* product claimed that a 5.5K *S*-encoded polypeptide was present in high copy number in purified phage particles obtained from S^+ and *Sam7* but not other *Sam* alleles (308). Since *Sam7* has a Trp \rightarrow UAG change at codon 56, the hypothesis was that the 5.5K species was an N-terminal polypeptide resulting from proteolytic cleavage. The presence of the 5.5K species could be correlated with a "resealing" function associated with the phage particles (307). The initial stages of λ infection are characterized by a loss of nucleotides and other small molecules to the medium. In normal infections, this leakiness is temporary and the infected cell appears to be resealed after about 5 min. In the absence of the 5.5K species, this temporary leakiness lasted much longer, leading to a cycle of diminished phage yield (307). This was an attractive model, since it is a classical observation in phage biology that the sealing of the infection-associated leakiness does not require phage protein or de novo host protein synthesis. Also, there was a certain symmetry in the idea that the *S* protein could be both a hole former and a hole sealer. However, analysis of proteins in highly purified phage particles found no evidence for an *S*-dependent species (10, 324), which, in any case, would have required extremely high levels of *S* expression to account for the $>10^3$ molecules per particle ob-

served. Yet another sighting of an S protein came in an undocumented claim from our laboratory that the product of the Sam7 allele accumulated in the membrane fraction (106). This was never reproduced and is also almost certainly spurious.

All these conflicting claims about S not only far exceeded the limited demand for molecular information about λ lysis but also jaded even those who were working on the problem. It was somewhat disappointing that the rather mundane 8.5K inner membrane species was the only one to survive close scrutiny, since this really did not help much in thinking about how the lysis "clock" operated. Thus, the reader cannot be blamed for being less than sanguine to hear that the 8.5K polypeptide band can in fact be resolved into two species, differing by two amino-terminal residues, and that these two species have opposing functions in lysis (36, 41)! Nevertheless, this new development rests fundamentally on genetics (244), always the more solid ground, and arguably has endowed λ lysis with a measure of molecular respectability.

Genetic Analysis of S and Discovery of the Dual-Start Motif

When the lysis cassette is cloned in a plasmid under the control of an inducible promoter, it is easy to select mutant alleles of *S* as survivors after induction (since *S* is the only lethal gene in the cassette). By using this kind of approach, a number of missense *S* alleles have been obtained and characterized at the primary sequence level (243). Moreover, with the power of λ genetics, it was a simple matter to transfer these mutant alleles back into the phage context by recombination with a ΔS phage and then assess the effect on plaque-forming ability and on the lysis profile of an induced lysogen. This also allowed testing for dominance and recessiveness by inducing double lysogens carrying the mutant allele on one prophage and S^+ on the other (244). Indeed, a full range of mutant phenotypes has been obtained, including both early- and late-lysing alleles and alleles which show dominant character, as expected for a protein which is thought to oligomerize to form holes (244). These mutants are discussed below, in the context of speculating about the structure of the S protein. None of these alleles was more informative, however, than point mutations upstream of the coding sequence which conferred negative dominant character (Fig. 3A). The only reasonable way to rationalize the dominance was to suppose that in these mutants, somehow an excess of a defective S protein was being produced. These mutations were mapped to different positions in the base-paired stem of a predicted stem-loop, designated *sdi*, encompassing the presumptive Shine-Dalgarno sequence for *S*. Several precedents suggested that, for genes which had such secondary structures occluding the ribosome-binding site, the efficiency of translation varied inversely with the predicted stability of the secondary structure (69, 124, 171). Thus, these mutations would be expected to increase *S* translation, rather than decrease it, especially considering that, for the mutations within the putative Shine-Dalgarno sequence, the base substitution would improve the consensus match of the sequence (from GGGG to GAGG or GGAG). The conclusion was that the product of translational starts at Met-1, designated S107 for its predicted length in amino acid residues, was not the functional *S* gene product but instead a nonlethal inhibitor of *S* function. By elimination, the true start codon for the lethal *S* gene would have to be Met-3, and the product, accordingly designated S105, would be the actual membrane holin or lysis effector (244). This model brings into focus a number of questions. (i)

How does the inhibitor prevent hole formation? (ii) Is the inhibitor produced in normal λ vegetative growth? (iii) If so, is the ratio of the two products constant during the vegetative cycle, or is it actively regulated? These questions are being pursued at the molecular level, and some evidence is available on all three.

Evidence for the Dual-Start Model

Before reviewing the evidence for the dual-start model, it is worth noting that *S* is not the first gene in which two protein products have opposing roles. Probably the best known precedent is the IS50 transposase gene, which occupies most of the functional right arm of Tn5 (80, 165, 166). There is good evidence that the full-length product of the transposase reading frame is the active transposase and that a secondary translational start, some 55 codons distal to the transposase start but in the same reading frame, serves as the initiation site for a nonfunctional transposase inhibitor. In this case, the switch between the longer and shorter forms is transcriptional, as a result of repression of the transposase promoter and activation of a downstream promoter between the two translational starts (183, 205). In the Tn5 effector-inhibitor pair, the inhibitor molecule is the shorter product, whose evolution is intuitively simpler since all that is required is to delete a sequence required for function, leaving an oligomerizing domain intact. For *S*, however, the inhibitory product is predicted to be larger, albeit by only two residues at the N terminus. It is not, then, the absence of a functional domain which makes S107 nonlethal but rather the presence of the extension, and this addition simultaneously confers inhibitory capacity.

The first and simplest prediction of the dual-start model is that eliminating the Met-1 codon not only would fail to inactivate the gene but also might actually increase its lethality, depending on whether the inhibitor was actually produced *in vivo*. As predicted, the Met-1 \rightarrow Leu (M1L) allele supports lysis significantly faster than S^+ without increasing the level of S105 protein (63, 244). As a result of this early lysis, which for an induced lysogen carrying the M1L allele occurs about 5 to 8 min before the normal time for lysis onset, the burst size is reduced more than threefold (63). The basic Lys-2 residue was the logical suspect for the inhibitory element, a suspicion which was supported by the finding that the altered *S* alleles K2T and K2E, but not K2R, are fast lysers compared with S^+ (36).

A close relative of *S* is gene *I3* of P22, with 89% identity at the amino acid level. Gene *I3* begins with the sequence Met-1-Lys-2-Lys-3-Met-4 . . . , and although the 5'-flanking sequence is not conserved, there is a potential stem-loop overlapping the putative Shine-Dalgarno sequence for Met-1 (Fig. 6). The *I3* dual-start region was tested for the effector-inhibitor functions by site-directed mutagenesis, and the results clearly demonstrate that the Met-1 and Met-4 codons serve the same roles as in *S*: i.e., translational starts for the inhibitor ($I3_{108}$) and effector ($I3_{105}$) proteins, respectively (229). Thus the two Lys residues in *I3* serve the same purpose as the single Lys-2 in *S*. In fact, there is some evidence that the *S* inhibitor protein, modified to have two Lys residues, is more effective in its inhibitor function, per molecule, than the normal S107, further implicating the positive charge in the inhibitory function (229).

In view of the consistent nature of the genetic and physiological evidence, it was essential to show that the *S* gene in fact does give rise to two protein products. The first evidence to this effect came from *S* Φ lacZ translational fusions,

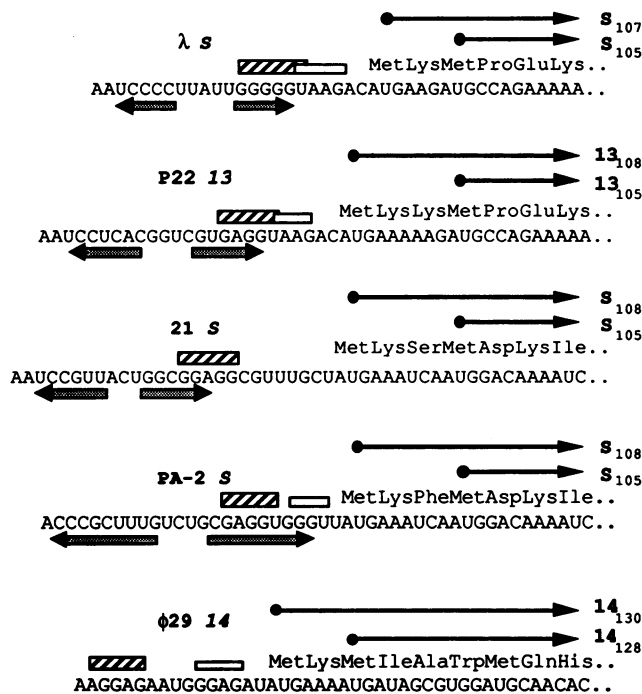

FIG. 6. Dual-start motifs in holin genes. The translational initiation region and N-terminal reading frames of the holin genes from the coliphages λ , 21, and PA-2, the *Salmonella* phage P22, and the *B. subtilis* phage ϕ 29 are shown, with arrows indicating the reading frames of the holin products. Inverted pairs of arrows indicate stem-loops demonstrated for λ and P22 (41, 229) and inferred for 21 and PA-2. The Shine-Dalgarno sequences for the longer (hatched boxes) and shorter (open boxes) reading frames are indicated. These have been documented for λ and P22 (41, 229) and are inferred for the other phage.

fused after codon 10 in the *S* gene. Fusions to M1L or M3L alleles were both Lac⁺, indicating that both start codons were used in vivo (41). Moreover, by using the toeprinting techniques developed in the laboratory of L. Gold (129), 30S ribosomes were shown to form ternary initiation complexes in vitro to both AUG codons (41). Finally, the two forms were directly detected by ultrahigh-resolution SDS-PAGE. After being labeled in vivo (with a T7-promoter expression system) or in vitro (with a cell-free S30 extract and purified *S* mRNA), the 8.5K membrane-bound species was resolved into two forms by extended electrophoresis (8,500 V-h) on long SDS-containing gels (36). The smaller species, which was about two- to threefold more heavily labeled, disappeared with the M3L allele, as did the larger using the M1L allele (36). Using antibodies raised against the product of an *S* Φ lacZ fusion gene (fused after codon 103 of *S*), Bläsi et al. detected two species of *S* and gp13 in Western blots of membrane material resolved on isoelectric focusing gels. In each case, the more basic species reacted much less intensely, indicating that the more acidic form was present in more than 10-fold molar excess, assuming, incorrectly as it turns out, equivalent reactivity to the antibody (36). By comparing the P22 gene 13 sequence with that of λ *S*, it was demonstrated that the apparent isoelectric points were exactly as predicted for the S105 and S107 forms of the *S* gene product and also for the predicted 105- and 108-residue products of gene 13. Using the T7 expression plasmid system, Bläsi et al. (36) also demonstrated that the two

products were not related by a processing event, since both species were stable to an extended chase.

Further support for the dual-start model can be derived from a systematic mutational analysis of the 5' region of the *S* gene, which was manipulated by site-directed mutagenesis to alter the partition of initiations at the two start codons. Using toeprinting to measure the formation of 30S ribosome-tRNA-mRNA ternary complexes over the two start codons, Bläsi et al. (41) found a strict correlation between the Met-3:Met-1 partition in vitro and the lysis time observed in vivo. Assuming that the partition of translational initiation complexes reflects the production of the two forms in vivo, one can conclude that the more S107 and the less S105 is produced, the longer before lysis begins, and vice versa. Finally, and most satisfyingly, when *S* is expressed in *trans* on a compatible plasmid, the lysis observed from an induced wild-type gene can be abolished entirely, provided that there is a sufficiently large excess of S107 (36). Moreover, addition of CN⁻ subverts this inhibition instantaneously, resulting in immediate lysis triggering. This suggests that the inhibitory capacity of the S107 protein depends on the energized membrane.

Phage 21 Lysis Genes: a New Kind of *S* Gene

Lambdoid phages show remarkable conservation in terms of the arrangement of genes (56, 84). Often, genes with identical map position in two lambdoid phages have identical functions and very similar sizes but highly dissimilar sequences. For example, little or no sequence similarity is found between the λ , ϕ 82, and phage 21 *Q* genes, even though each encodes a basic protein with a predicted molecular weight of 18,000 and they have an identical role in the vegetative cycle (112, 122). The lysis cassette is in the same position in the late transcriptional unit in λ and P22 and is structured in the same way in both phages (Fig. 5). The middle genes, *R* in λ and *19* in P22, encode enzymes which degrade the peptidoglycan; however, as discussed above, the two genes are totally unrelated in terms of both sequence and the encoded enzyme activity. Since evolution of lambdoid phage is thought to involve repeated recombinational exchanges with a variety of heteroimmune prophages (56), the near identity of the *S*/13 gene pair and the total dissimilarity of *R* and *19* led Botstein to propose that the gene, rather than a group of related genes, was the unit of exchange (48). Dramatic support for this notion was recently obtained, when it was discovered that the lambdoid phage 21 had no DNA which would hybridize with a probe consisting of the λ *S* gene, yet had lysis characteristics (e.g., elaboration of a lysozyme activity, CN-induced premature lysis) indistinguishable from those of λ (47). The entire phage 21 lysis gene region was sequenced, revealing that gene *S*²¹, although occupying the same position in an *SRRz* lysis gene cluster, was unrelated to *S* (Fig. 5; see also Fig. 8). Moreover, as judged by sequence homology, the *R*²¹ gene encodes a true lysozyme of the T4 *e* and P22 *19* family. Finally, the *Rz*²¹ gene is the most highly conserved, which seems a bit perverse since its function is dispensable. Comparison to the sequence data base yielded another surprise, i.e., that the lysis region of yet another lambdoid phage, PA-2, has been available for years, having been determined *pari passu* in the search for a phage-borne gene encoding an outer membrane protein (33). Unfortunately, omission of a single base during the sequencing had disrupted the *S*^{PA-2} reading frame and thus prevented its recognition as a potential gene. Otherwise, the 21 and PA-2 lysis gene regions are very

similar. Thus far, then, after characterization of four lambdoid phage lysis gene cassettes, there are two unrelated kinds of both *S* and *R* genes and a single class of *Rz* gene (Fig. 5). Denoting the gene types found in λ as class I, one can abbreviate the lysis gene clusters of λ , P22, and 21/PA-2 as I-I-I, I-II-I, and II-II-I arrays, respectively, which supports Botstein's hypothesis. Syvanen (286) has suggested a "Chinese menu" mode of lambdoid phage evolution, in which lambdoid phage can select, recombinationally, alternative versions of particular genes by recombining with the ubiquitous lambdoid prophages. A requisite for this, however, is that the gene positions should be separated by recombination-proficient joints, presumably rich in sequence similarity. No such feature is detectable in the intergenic junctions of the lysis cluster. In fact, since there is overlap (of 1 bp or more) at the *S*-*R* and *R*-*Rz* junctions in all four lysis cassettes, the putative recombination sequences must be embedded within the reading frames of these diverse genes.

*S*²¹: Conservation of the Dual-Start Motif

Intriguingly, even though *S* and *S*²¹ are utterly dissimilar in sequence and size (107 and 71 codons, respectively), it appeared that *S*²¹ and the related *S*^{PA-2} share the dual start motif, encoding a polypeptide beginning with Met-Lys-X-Met . . . at the N terminus (Fig. 6). To test whether the two start codons are both used and whether they serve the same functions as in λ , site-directed mutagenesis of plasmid-borne clones was used to create M1L and M4L alleles of *S*²¹. Although these alleles have not yet been transferred back to a phage context, at least in the plasmid environment the M1L allele is much more toxic and supports accelerated lysis compared with wild-type *S*²¹, whereas the M4L allele is nonlytic (47). This supports the notion that the predicted products of *S*²¹, which would be *S*²¹71 and *S*²¹68, serve as lysis inhibitor and effector, respectively, just as for the S107 and S105 products of λ *S*. Labeling experiments analyzed by immunoprecipitation with antibodies raised against a C-terminal oligopeptide of *S*²¹ clearly identify the two *S*²¹ proteins, which are somewhat easier to resolve than the λ products because of the larger percent difference in the polypeptide masses between the 71- and 68-residue products. Although this analysis will not be conclusive until the mutated alleles are transferred back into the phage context, these data indicate that it is the presence of Lys-2 between the Met-1 and Met-4 codons in the 21 and PA-2 genes that confers the inhibitor characteristic of *S*²¹71. From preliminary sequence data obtained by Kadosh et al., it appears that the lambdoid phage ϕ 80 *S* gene is highly related to *S*²¹/*S*^{PA-2} and begins with the codons Met-Tyr-Arg-Met . . . (176), indicating again that it is the presence of a positively charged residue, rather than an Lys residue specifically, which confers the inhibitor phenotype on the longer product. Moreover, it appears that the dual-start motif either survived extreme divergence during the evolution of the *S* genes of λ and 21 or arose in a convergent fashion. In either case, the implication is that there is a powerful selective pressure for the presence of the dual-start system.

Analysis of Primary Sequence and Topology Predictions

The small size of the *S* and *S*²¹ reading frames makes it difficult to resist engaging in some protein structure prediction. The prediction of secondary structure for membrane-bound proteins is controversial (93, 168, 297), but some

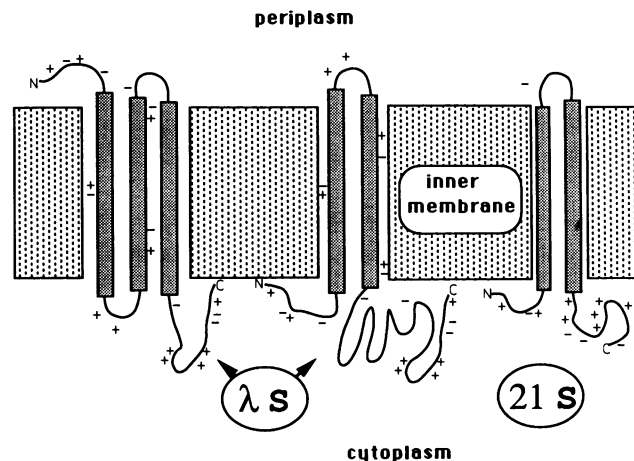

FIG. 7. Models for disposition of λ and 21 holins in cytoplasmic membrane. Transmembrane helical domains are represented by the stippled vertical rectangles. N and C indicate the amino and carboxy termini, respectively. Residues with charged side chains are indicated at their approximate positions by + or - adjacent to each model. The λ *S* protein, in its S107 form, is depicted with either three (left) or two (middle) transmembrane domains (47, 244). In both cases, the first domain spans residues 13 to 32 and the second occupies residues 41 through 60. In the left model, the third transmembrane domain spans residues 65 through 84. The *S*²¹ model (right) has the N-proximal transmembrane domain spanning residues 9 through 28 and the C-terminal domain from residues 37 through 56.

simple generalizations are possible. First, hydrophobic domains of 19 to 22 residues are, almost without exception, transmembrane alpha helices (168). Second, the sequences between two transmembrane helices which are close together in the primary sequence usually have a high probability for a beta turn according to the Chou-Fasman algorithm (64, 168). Consequently, it is a reasonable guess that the protein products of the *S* genes of both λ and 21 have, within the first 60 or so residues, two membrane-spanning domains separated by a hydrophilic beta-turn region (Fig. 7 and 8A). To accommodate two membrane-spanning domains in *S*^λ without burying a charge in the bilayer, one must assume that two intrahelical ion pair salt bridges exist: Lys-18::Glu-19 in the N-proximal membrane domain, and Lys-43::Asp-47 in the second domain. However, it is also possible that neutralization of these charges is accomplished interhelically or intermolecularly, perhaps by the formation of *S* aggregates. Another similarity is the short polar domain between the two putative membrane-spanning helices, which by virtue of three Gly residues in *S* and a Pro in *S*²¹ are likely to be reverse-turn domains, allowing the chain the flexibility to reorient back into the bilayer. Also, both *S* and *S*²¹ have charge-rich carboxy termini (7 of 16 charged for *S*, net +3; 9 of 13 charged for *S*²¹, net +3), which one would presume would be cytoplasmic anchors.

Before the discovery of *S*²¹, there was little other than the hydropathicity pattern of *S* on which to base any models for the disposition of the lysis protein in the membrane. Although the hydropathicity patterns of *S* and *S*²¹ are very similar, there is a charge-free region in *S* (residues 63 to 83) which does not have a counterpart in *S*²¹ and which we originally assigned as a putative transmembrane domain (244). Since we felt compelled to keep the highly charged and extremely hydrophilic C terminus in the cytoplasm, our

original model had three transmembrane domains with the N terminus in the periplasm. It must be emphasized that the new model (Fig. 7) is now favored mainly for reasons of intellectual economy, in that it seems most reasonable to have both λ and 21 S proteins with two membrane-spanning domains disposed in a topologically homologous fashion.

Mutational Analysis

S is ideally suited to mutational analysis because it is small and lethal when expressed from moderately active promoters. Despite repeated efforts, no host mutations which confer insensitivity to S expression have ever been isolated. The conclusion we draw is that S acts without interacting with host proteins, in contrast to the lysis gene of ϕ X174, which requires a single host locus for its lytic function (see below). Support for this inference can be drawn from the fact that induction of S cloned in a plasmid under *GAL10* control in *Saccharomyces cerevisiae* results in efficient cell killing (104). This facilitates mutational analysis of S, since all the *E. coli* mutants which survive S expression are S mutants. Many such mutations have been isolated (243). Fortuitously, mutations which debilitate S expressed from *lacP* often have only partial phenotypes, if any, when transferred back to the context of the phage genome. Thus a large number of S missense alleles with a wide spectrum of phenotypes have been isolated and characterized, at least in terms of phage physiology (244). With reference to the model presented above, these mutations were located primarily in the two membrane domains (15 different mutated residues represented among 23 different alleles) and in the putative turn region (six alleles, including all three Gly residues) (243). By using the tight non-plaque-forming alleles, one can select spontaneous intragenic suppressors as pseudorevertants with plaque morphologies distinct from those of the S⁺ true revertants (170, 279). Although only a few of these have been sequenced, at least two kinds of interesting suppressions have already been found. First, two different mutations which create net positive or negative charge in one putative transmembrane domain can be suppressed by mutations which endow a side chain in the other transmembrane domain with a neutralizing charge. This suggests that net neutrality is an essential feature of the holin membrane domains and also that salt bridging is possible between the transmembrane helices. Second, mutations which eliminate one of the three Gly residues in the putative beta-turn region separating the transmembrane domains can be suppressed by removal of a second Gly in the same region, suggesting

that the geometry of redirecting the polypeptide chain back toward the membrane is favorable with one or three, but not two, turn-generating residues (280). Enough suppressors have been sequenced, at least, to demonstrate conclusively that no pattern of global suppression is emerging, so the attractive idea of creating lesions at strategic loci (i.e., putting a positive charge at a given position in a transmembrane domain) and mapping interaction sites by allele-specific suppressors seems feasible. Each mutant was also tested for dominance and recessiveness by recording the lysis profile resulting from induction of a double lysogen, with one copy of the wild-type S and one copy of the mutant allele. As mentioned above, this analysis led to the discovery of the dual-start motif, but in retrospect we now see another important finding which was overlooked. A number of dominant, or, *sensu strictu*, codominant, alleles were found, which caused a double lysogen to show delayed lysis. These were scattered about the gene, with the exception of the second membrane domain, which we argued was weak evidence indicting this domain in S oligomerization. Curiously, a number of non-plaque-forming, nonlytic alleles showed a very unusual phenotype in the double-lysogen test, with onset of lysis occurring sooner than in the double wild type! Formally, this behavior makes these alleles codominant (243). At the time, we attributed this unexpected early-lysis codominance to some kind of titration effect on the putative inhibitor form of S, and this may still be correct for some of these alleles. However, the unexpected properties of a recently discovered mutant make another interpretation possible. The mutation Ala-52 to Gly (A52G) results in a non-plaque-forming allele with an extreme early lysis phenotype: lysis onset is at 19 min after induction of the lysogen, about 20 min earlier than for the wild type and only 10 to 12 min after the beginning of late protein synthesis (170). As a result of this attenuated vegetative period, the yield of phage is very low, about 10⁻¹ to 10⁻² particles per cell. If a lysogen with the S⁺ allele is prematurely lysed by CHCl₃ at the same time, a identical burst of phage particles is obtained, indicating that the sole defect in the mutant phage is the A52G lysis defect. The analysis of this mutant is still in its preliminary stages, but if its properties are confirmed, it puts an entirely new perspective on S function. That is, S can be nonfunctional either by failing to cause lysis or by causing lysis too early. Two other alleles exist with alterations at the same residue, one (A52T) with a delayed lysis phenotype (88 min) and the other (A52V) which is totally lysis incompetent (244). To determine whether the lysis clock is set by the size or polar character of side chains

FIG. 8. Primary sequence of phage lysis proteins. The charged side chains are indicated by + and - above the sequence. In all cases, potential transmembrane domains, defined here as regions of 20 generally hydrophobic residues with no net charge (except for P1 LydA, with one negative charge in the second such domain), are indicated by the underscored solid bar. The domains of λ S and P22 gp13, which, although uncharged, are of questionable value as transmembrane domains (see text), are indicated by colons below the sequence. Potential beta-turn regions as predicted by the Chou-Fasman prediction algorithm are indicated by consecutive lowercase t's below the sequence. Potential or demonstrated dual starts are indicated by #. The highly charged C-terminal domains of the holins and putative holins are indicated by groups of asterisks below the sequence. (A) Holins. The amino acid sequences for the known or suspected phage holins λ S (76), P22 gene 13 product (250), phages 21 and PA-2 S (47), T7 gene 17.5 product (85), T3 Lys (314), P1 LydA (160), Hp1 ORF78 product (20), ϕ 29 and PZA gene 14 products (233, 296), PRD1 ORFm product (17), and T4 t (220, 251) are shown. Because of its larger size, the T4 t gene product is shown as discontinuous sequences connected by a thin line. (B) Nonholin lysis proteins. The amino acid sequences for the E lysis proteins of ϕ X174 (19) and the closely related phage G4 (109), the L lysis proteins of MS2 (94) and the related group I RNA phages GA and fr (4, 6), ϕ 6 P10 (116), and PM2 sp6.6 (13, 209) are shown. The ϕ X174 E protein differs from the first published sequence (19): residue 89 is a Gln (Q) rather than the Arg (R) originally reported (133, 223). The last 25 residues of the MS2 L protein sequence, shown in boldface letters, correspond to the L25 peptide used in the *in vitro* system of van Duin and colleagues (see the text). Below the MS2 L sequence are the sequences of the products of the lysis-proficient N-terminal deletion alleles cL66, cL42, and cL32 (26). Alignments of these sequences are chosen to maximize amino acid sequence homology. The sequence of the ORF *lysB* of the *Lactobacillus* phage mv1 was kindly provided before publication by L. DuPont, B. Boizet, M. Mata, and P. Ritzenthaler. Its inclusion in this list is not meant to imply that LysB is involved in lysis.

A

λ S

```

+ - - - - + - - + - - + - - + - - + - - + - - + - - + - - + - - + - - +
MKPRKHDLLAALAAKEGGIGAILAFAMAVL RGRYNGAGFTKVIDATNCAI IAFIRDLLDFAGLSSNLAYITSVFI
# # # # # # # # # # # # # # # # # # # # # # # # # # # # # # # # # # # # # # #
# # # # # # # # # # # # # # # # # # # # # # # # # # # # # # # # # # # # # #
+ - - - - + - - + - - + - - + - - + - - + - - + - - + - - + - - + - - +
MKPRKHDLLTAMMAAKEGGIGAILAFAMAVL RGRYNGAGFKTLIDATNCAI IAFIRDLLVFAGLSSNLAYIASVFI
# # # # # # # # # # # # # # # # # # # # # # # # # # # # # # # # # # # # # # #
# # # # # # # # # # # # # # # # # # # # # # # # # # # # # # # # # # # # # #
+ - - - - + - - + - - + - - + - - + - - + - - + - - + - - + - - + - - +
MKSNDKISTGIAVGTSAAGYVFLLQMLDQVSPQMAAIGVLSVLFGLTYL TNLVFKIREDRKAARGE
# # # # # # # # # # # # # # # # # # # # # # # # # # # # # # # # # # # # # # #
# # # # # # # # # # # # # # # # # # # # # # # # # # # # # # # # # # # # # #

```

21 8

```

+ - - - - + - - + - - + - - + - - + - - + - - + - - + - - + - - + - - +
MKSNDKISTGIAVGTSAAGYVFLLQMLDQVSPQMAAIGVLSVLFGLTYL TNLVFKIREDRKAARGE
# # # # # # # # # # # # # # # # # # # # # # # # # # # # # # # # # # # # # # #
# # # # # # # # # # # # # # # # # # # # # # # # # # # # # # # # # # # # # #

```

PA-2 8

```

+ - - - - + - - + - - + - - + - - + - - + - - + - - + - - + - - + - - +
MKFWDKLTGAVVGTSAAGYVFLLQMLDQVSPQMAAIGVLSVLFGLTYL TNLVFKIREDRKAARGE
# # # # # # # # # # # # # # # # # # # # # # # # # # # # # # # # # # # # # # #
# # # # # # # # # # # # # # # # # # # # # # # # # # # # # # # # # # # # # #

```

T7 gp17.5

```

- - - - - + - - + - - + - - + - - + - - + - - + - - + - - + - - + - - +
MLSLDFNNELIKAPIVGTGVADVSARLFFGLSLNEFYVAALAYTVVQI GAKVQKMLDQKKAKE
# # # # # # # # # # # # # # # # # # # # # # # # # # # # # # # # # # # # # # #
# # # # # # # # # # # # # # # # # # # # # # # # # # # # # # # # # # # # # #

```

T3 Lys

```

- - - - - + - - + - - + - - + - - + - - + - - + - - + - - + - - + - - +
MLSLDFNNELIKAPIVGTGVADVSARLFFGLSLNEFYVAALAYTVVQI GAKVQKMLDQKKAKE
# # # # # # # # # # # # # # # # # # # # # # # # # # # # # # # # # # # # # # #
# # # # # # # # # # # # # # # # # # # # # # # # # # # # # # # # # # # # # #

```

Hp1 ORF7 8

```

+ - - - - + - - + - - + - - + - - + - - + - - + - - + - - + - - + - - +
MNSKIDSAIPIFISL TALSIVSLHEMASLFGILFGAVSWIAVRKYKEDVQARDELA YKMLVAKTEAKKIGIAIDE
# # # # # # # # # # # # # # # # # # # # # # # # # # # # # # # # # # # # # # #
# # # # # # # # # # # # # # # # # # # # # # # # # # # # # # # # # # # # # #

```

φ29 P14

```

+ - - - - + - - + - - + - - + - - + - - + - - + - - + - - + - - + - - +
MKMIAMQHFLETDTELKLYL TFLMVGWVDYLVGV FAKLNPNIKFSSFKIKTGVL IKVSEMI LALLAIPFAVPPFAGL
# # # # # # # # # # # # # # # # # # # # # # # # # # # # # # # # # # # # # # #
# # # # # # # # # # # # # # # # # # # # # # # # # # # # # # # # # # # # # #

```

P2A P14

```

+ - - - - + - - + - - + - - + - - + - - + - - + - - + - - + - - + - - +
MTMIAMQHFLETDTELKLYL TFLMVGWVDYLVGV FAKLNPNIKFSSFKIKTGVL IKVSEMI LALLAIPFAVPPFAGL
# # # # # # # # # # # # # # # # # # # # # # # # # # # # # # # # # # # # # # #
# # # # # # # # # # # # # # # # # # # # # # # # # # # # # # # # # # # # # #

```

PRD1 ORFM

```

+ - - - - + - - + - - + - - + - - + - - + - - + - - + - - + - - + - - +
MPFGLIVIGIILAIAYRDTIGELFSSIKDVKDAKGFYVLAAILGF AATSKPIKEPVNAFMILLIVLLIRKRGALDQISNQLRGS
# # # # # # # # # # # # # # # # # # # # # # # # # # # # # # # # # # # # # # #
# # # # # # # # # # # # # # # # # # # # # # # # # # # # # # # # # # # # # #

```

T4 t

```

+ - - - - + - - + - - + - - + - - + - - + - - + - - + - - + - - + - - +
MAAPRISFSPDILFGVLDRLFKDNATKVLASVAVVILLFI MAIIVWRGDSFEFYQSKYETYSIEIERARRESVALEQLQI
# # # # # # # # # # # # # # # # # # # # # # # # # # # # # # # # # # # # # # #
# # # # # # # # # # # # # # # # # # # # # # # # # # # # # # # # # # # # # #

```

```

- - - - - + - - + - - + - - + - - + - - + - - + - - + - - + - - + - - +
VDKTMDEYTVHLNGRHYYNSKFAFLPTKKTPEINVMYSCPVFNLDNIYAGTITMYVYRNDHISNDRLEISICQAARILGRAK
# # # # # # # # # # # # # # # # # # # # # # # # # # # # # # # # # # # # # # #
# # # # # # # # # # # # # # # # # # # # # # # # # # # # # # # # # # # # # #

```

at just one or a few residues, including residue 52, a search for more mutants with severe early lysis defects is under way. In addition, a slow-lysing, plaque-forming pseudorevertant of A52G has been isolated and found to have acquired an *sd1* mutation (170) shown to destabilize the *sd1* secondary culture (Fig. 3A) and cause an increase in the S107/S105 production ratio. This indicates that even with the A52G change, the S107 protein still functions as an inhibitor. In any event, despite the present reliance on cartoons and sequence gazing, this rich collection of mutants with diverse phenotypes gives promise that the mechanism of S function may ultimately be tractable at the molecular level.

Imagining the S-Dependent Hole

A final consideration at the theoretical level must be made: given the model for S disposition above, can one estimate minimum stoichiometries for the formation of the S-dependent hole? Making the assumptions that the R endolysin is globular and monomeric like the T4 *e* lysozyme (which seems reasonable since the P22 gene 19 product complements R and is similar to *gpe*) with a largest dimension of about 5 nm, that the lesion is composed exclusively of S proteins, and that each S monomer is disposed as a pair of alpha helices spanning the bilayer, one can imagine two simple models for the S-dependent hole. In one model, with two membrane-spanning helical domains participating as wall units of the hole, one could obtain a 5-nm hole with about 12 to 15 S monomers, whereas about twice as many are needed if only one helical domain participates. Several attempts have been made to quantitate the amount of S present at the time of the lethal hole formation event. Zagotta and Wilson purified S protein cleaved in vitro from an S- β -galactosidase fusion and used this as a standard for comparative Western blot analysis of the host membrane. They concluded that there were 10^2 to 10^3 S molecules in the membranes of an induced lysogen at the time of lysis (324). A similar number is obtained if one quantitates S- β -galactosidase activity after induction of plasmid clones carrying an active *S Φ lacZ* fusion gene and determines from this the number of hybrid protein molecules present at a time when an isogenic S clone causes lysis (245). In preliminary results in my laboratory, Chang has been able to obtain sufficient purified S105 and S107 to be detectable by the standard SDS-PAGE stain Coomassie blue. Assuming that the dye binds with similar affinity to either form of S as it does to standard proteins, one can estimate protein concentrations which, again, can be used for comparative Western blot analysis. On this basis, we estimate that about 3,000 S molecules are present in the membranes of the lysed cell. With the 300 to 3,000 range for S molecules and a minimum of 15 molecules per hole, the total number of holes cannot exceed 200 and could be much smaller if such a hole requires a surrounding cluster of S monomers. This has tempered our enthusiasm for looking for S-dependent holes by electron microscopy, even with the availability of the immunogold technology applied with great success to the lysis protein of the RNA phage MS2 (see below).

Probing S In Vivo

Very little is known about the secondary, tertiary, or quaternary structure of the S proteins, S105 to S107 heterooligomeric aggregates (which presumably form in the membrane before hole formation), or the S-dependent holes. Zagotta and Wilson (324) purified small amounts of S protein

to electrophoretic homogeneity by immunoaffinity chromatography and were able to show that SDS-resistant dimers formed and survived electrophoresis. Moreover, when membranes of induced lysogens were subjected to cross-linking with the homobifunctional agent dithiobis (succinimidylpropionate) (DSP) and analyzed by Western blotting, a ladder of immunoreactive bands at M_r 9,000, 18,000, 24,000, 32,000, and 42,000 was obtained (presumably monomers and 2, 3, 4, and 5-mer species, respectively). This ladder indicates that the S protein is highly oligomeric, as suggested by the frequency of alleles with dominant character (244). The S protein can also be detected in the membrane fractions of yeast cells killed by S expression (104). Much higher levels of S can be detected by Western blotting in yeast membranes than in lysed bacterial membranes. Moreover, a number of higher-mass forms are seen, with apparent masses consistent with the formation of multimers which survive electrophoretic resolution on SDS-PAGE gels.

It is now customary to probe membrane topology by constructing *phoA* and *lacZ* fusions (96, 107, 198). Gene fusions to *lacZ* at S codon 75 and at 89 or beyond generate hybrid enzymes which are not only membrane bound but surprisingly nontoxic and possess approximately normal β -galactosidase specific activity on a per-molecule basis (63, 242, 324). This suggests that the N-terminal S sequences in these hybrids are oriented in such a way that the fused enzyme domains are cytoplasmic, which is consistent with the model presented above (Fig. 7). (This is also weak evidence against the old model for S topology, since residue 75 would be in the middle of the third transmembrane domain.) Fusions within the first two putative transmembrane domains are apparently inactive in terms of β -galactosidase activity but otherwise have not been characterized (245). So far, *phoA* fusions have not been informative. Bläsi has found that *S Φ phoA* fusions at codons 35, 60, and 90 have no detectable alkaline phosphatase activity, even when expressed from efficient promoters and efficient ribosome-binding sites on multicopy plasmids (34). These preliminary results would seem to conflict with the properties of the *lacZ* fusions and cast some doubt on the model, which predicts that the codon 35 fusion would have the PhoA moiety in the periplasm (and thus possess alkaline phosphatase activity). No fusion analysis has yet been performed on S²¹.

In preliminary work in my laboratory, C.-Y. Chang has probed the accessibility of S107, labeled in vivo with [³⁵S]methionine, to proteinase K digestion in both spheroplasts and everted vesicles. In preliminary immunoprecipitation experiments with an antibody raised against a synthetic peptide corresponding to the C terminus of S, it appears that the C terminus of S107 is sensitive to added protease in everted vesicle preparations but not in spheroplasts, which supports the model. In contrast, the PhoA domain of the *S Φ phoA* codon 35 fusion is protected from protease attack in spheroplasts (34). The apparent conflict between these findings will no doubt be resolved when these efforts move beyond the preliminary stage.

The antibodies originally used by Zagotta and Wilson (324) to detect S in vivo were raised in rabbits by using the affinity-purified S- β -galactosidase hybrid protein as antigen. Recently we discovered that this antiserum has the peculiar property of recognizing only S105 in immunoprecipitation experiments, although it retains some affinity (about 10% relative to S105) for S107 in Western blots (63). A second antibody raised in our laboratory against a similar *S Φ lacZ* fusion product also possesses this specificity, whereas the antibody raised against the synthetic C-terminal polypeptide

reacts equally well with both S105 and S107 in immunoprecipitations (63). The specificity of the hybrid protein antiserum led us to overestimate the S105/S107 molar ratio in membranes of lysed cells (36) and is totally unexpected, since one would predict, if anything, that the S107 species would have an additional epitope which might dominate a polyclonal preparation. Whether this peculiar specificity reflects something about differences in topology or conformation of S105 and S107 is not yet known, but any such difference must persist under the nonionic detergent conditions used for the immunoprecipitation protocols.

How Does the Inhibitor Work?

How does S107 act as an inhibitor? Since we have no physical and little biochemical evidence for how S105 works as a holin, it is silly to build detailed models. However, we can construct a working hypothesis which explains the CN⁻-triggering or premature lysis phenomenon by using the one feature we know, from genetics, to be essential to inhibitor function. In this model, the S107 molecule is drawn as an integral membrane protein with the positively charged N terminus protruding from the cytoplasmic face and interacting ionically with the excess negative charge at the inner surface of the energized membrane (Fig. 7). This interaction in some way prevents S107 from participating in hole formation. Since we expect S-dependent holes to form from oligomeric assemblies of S monomers, it is not unreasonable to suggest that the presence of the inhibitor molecules in a membrane aggregate poisons the hole formation. Collapse of the membrane potential would reduce or eliminate the coulombic interaction and thus potentiate the existing S105-S107 heteroaggregates to rearrange into holes. Premature lysis can also be triggered even when only S105 is being produced, and replacement of the Lys-6 residue with a Thr also accelerates the onset of lysis by about the same amount as elimination of S107 does (34). This suggests that the membrane potential inhibits both S105 and S107 from the conformational change or subunit rearrangement required for hole formation. The distinction would be that S107 is inhibited significantly more. It is worth noting that the lysis observed upon CN triggering when S107 is produced at sufficient levels to block S⁺ in *trans* is more rapid than the isogenic control with only a plasmid vector in *trans* (36). This suggests that S107 is actually converted into a lysis effector by the collapse of the membrane potential.

Regulation of S Expression

Given the existence of the S dual-start regulatory system, the question arises of whether the expression of its effector-inhibitor pair is actively regulated during the vegetative cycle. The S gene is transcribed constitutively after the Q-dependent turn-on of late-gene expression at 8 min. The concentration of S mRNA, as assessed by the RNase protection assay (Ambion, Austin, Tex.), increases in an approximately linear fashion from 8 min until about 25 min and then remains constant at about 240 molecules per cell (228). From this, we can deduce that the average translation rate for the S mRNA, assuming that all of the molecules detected by RPA are functional, is about 0.1 to 0.5 polypeptide per min over the vegetative cycle. This low rate is consistent with the β-galactosidase activities obtained with the SΦlacZ fusions. The restricted expression of S stands in stark contrast to the 10²- to 10³-fold-higher levels of translation of the E cistron, located 10 kb downstream on the same

primary transcript (261). There is RNase III processing at two sites 420 and 340 nt upstream of S (Fig. 3B), but S mRNA purified at any point during the late-gene expression period shows the same Met-1/Met-3 partitioning of ribosome binding, assessed by toeprinting, as does intact S mRNA transcribed in vitro. This indicates the RNase III cleavage events have not effect on the intrinsic translatability of the S mRNA (228). Pulse-labeling with [³⁵S]methionine has demonstrated that both S105 and S107 are produced throughout the late protein synthesis period, with a total accumulation that is biased about 2.5:1 in favor of S105 (63). At this point, the data on whether the S107/S105 ratio changes during infection are not conclusive. What is clear is that upstream sequences are involved in S translation, since in Δ119, a deletion of the 190 nt immediately 5' of the *sdi* stem-loop (Fig. 3B), translation of S is reduced 10-fold or more. Incorporation of this allele into the phage genome results in a severe delay in lysis (to about 140 min) and a tiny-plaque phenotype (63). This reduced translatability is not due to degradation of the Δ119 mRNA, which accumulates to normal levels, or to a loss of intrinsic capacity for ribosome binding, since the toeprint assay of the Δ119 mRNA is indistinguishable from that of the wild type.

These data suggest that the upstream sequences might serve to bind a factor required for S translation. Mobility shift assays with fragments of the S mRNA as a probe indicated the presence of an RNA-binding activity specific for the upstream sequences missing in Δ119. Cross-linking with UV light permitted assignment of the binding activity to a soluble host protein of *M_r* ≈ 65,000 (228). The protein has been substantially purified and awaits N-terminal protein sequencing as a first step in its identification. Although it seems likely that the 65K host RNA-binding factor is required for the translation of S, as limited as it is, it is still unclear whether this positive control modulates S production during the vegetative cycle.

Other Models for λ Lysis

In a series of papers on the physiology of λ lysis, Campbell and Rolfe developed an intricate model in which it was proposed that lysis is under double control: a positive control by the S gene product, and a negative control by a lysis regulator (LR), thought to be an unstable protein which must be continually resynthesized (58, 253, 254). Accordingly, the phage could accomplish lysis in two distinct ways: either by activating the S system or by subverting the LR. The normal, sharp lysis profile displayed by an induced lysogen or a synchronously infected culture (lysis I) was proposed to require S (58). A second mode, lysis II, is S independent and occurs over a broad distribution of times in the vegetative cycle, beginning in some cells as early as 20 min after induction. The S pathway is activated by energy poisons to overcome LR, which is inhibited by such poisons. In an S⁻ vegetative phase, lysis II can be observed when LR synthesis is inhibited by chloramphenicol or when LR is inactivated by host mutations in any of at least 11 loci including *tolA*, *tolB*, *tolP*, *uncA*, *uncB*, and *cya* (253). Two basic observations underlie this complex scheme. First, the authors observe that λ Sam7 is able to form plaques on the host mutants cited above. However, the efficiency of plating is, with one exception, only 1% or less, which, although 10⁴- to 10⁵-fold higher than the plating efficiency of λ Sam7 on a nonsuppressing wild-type host, hardly counts as a physiologically meaningful lysis strategy. In the one exception, a *cya* mutation allows plating at 50% efficiency, and yet

another *cya* allele is completely nonpermissive. The lysis profiles of one of the mutant hosts, *tolB*, are provided (58, 253) and show that lysis begins very early (at about 18 min after induction) and is extremely gradual, requiring more than 2 h to achieve a 75% reduction in turbidity. Moreover, this gradual and uncoordinated lysis profile is obtained even with λ S^+ . This suggests that the lysis II is really not a second lytic pathway but merely the deterioration of infected cells already defective in important aspects of membrane function. A few phage are produced and released in some cells undergoing this vegetative deterioration, leading to the leaky plaque-forming phenotype. The second observation critical to the model is that chloramphenicol causes triggering of lysis independent of *S* function. Again, inspection of the lysis curves reveals that, in an S^+ induction, chloramphenicol triggers a sharply defined lysis after about a 5-min delay, whereas in an S^- induction, lysis begins more than 30 min after addition of the drug and is very gradual. It must be stated clearly that we do not understand how chloramphenicol can trigger premature lysis in an S^+ infection. It is not a drug-specific effect, since other protein synthesis inhibitors or any other direct blockage of protein synthesis has the same effect if implemented during the late protein synthesis phase (248, 279, 322). In addition, chloramphenicol does not trigger premature lysis of cells in which the cloned lysis genes have been induced (105). Although there is no satisfactory explanation for this kind of premature lysis, the substantial delay before the onset of rapid lysis makes it likely that inhibiting protein synthesis leads indirectly to *S* triggering. In any case, the chloramphenicol-dependent lysis under S^- conditions (58) is clearly dissimilar at the physiological level, since it is abolished by energy poisons (58), is extremely gradual, and in fact does not even require endolysin synthesis (279).

These authors also implicate a λ gene, *rex*, in the inhibitory function of the LR system, on the basis of the observation that in minimal glucose or in anaerobic broth medium (but not in aerobic broth culture) induction of λ *rex* lysogens leads to advanced onset of lysis by 10 to 15 min (254). In light of the more recent findings that the *rex* locus encodes two proteins, at least one of which is a membrane protein (204, 270), this would be very intriguing. However, hybrid phage carrying the *imm*⁴³⁴ immunity region, which lacks a *rex* locus, has normal lysis properties (170), and a *rex::Tn903* insertion has no effect on lysis (322). Rolfe and Campbell reported the isolation of λ *clo* mutants by selecting for phage released early from an induced lysogen (254). Some of these exhibited a reduced Rex phenotype as prophages, which added support to the notion that *rex* is involved in lysis regulation. However, no further information on these *clo* mutations has appeared since, and without mapping information it is difficult to assess the significance of these genetic data. In sum, there does not seem to be substantive cause for considering such a complex model for λ lysis. In fact, Rolfe and Campbell ended the series with a rather simpler picture which happens to fit well with current models based on both genetics and molecular biology: "The *S* protein is capable of existing in two states, one active and the other inactive. . . . Poisoning the cell with cyanide can also convert the *S* protein to the active state prematurely. The active *S* protein insults the cell membrane and allows the endolysin to destroy the cell wall" (254).

Current Questions and Perspectives

S has really come of age as a genetic entity, with functional and regulatory subtleties which may ultimately compare with those of its more famous siblings *cI* and *N*. This is perhaps not surprising in view of its simple primary structure and capability of being subjected to both positive and negative selections (in the phage and plasmid contexts, respectively). Actually, the simplicity of the genetic system is a bit misleading. It is somewhat disheartening that, for most nonfunctional *S* alleles, we do not know whether the defect is due to dysfunction of the effector (S105) or hyperfunction of the inhibitor (S107), or both! Sorting this out will mean separating each interesting mutation into alleles which will produce only S105 or S107 and retesting the lysis phenotype. It is also imperative that the extensive mutant collection receive some characterization at the molecular level in vivo. With the new immunological reagents in combination with technologies such as DSP cross-linking, the various mutant alleles can be classified in terms of protein stability, membrane-binding kinetics, topology in the bilayer, and oligomerization state. There are significant questions which require innovative approaches still in development. For instance, we still do not know the stoichiometry of *S* molecules in the lethal *S*-dependent holes or even whether the holes are uniform or variable in effective diameter. This and other avenues of inquiry await the establishment of an in vitro system for *S*-dependent hole formation. Recent results suggest that it will be possible to synthesize biochemically useful quantities of fusion proteins, from which full-length *S* molecules can be released by chemical or enzymatic cleavage (227, 266). If so, this permits experiments in which *S* could be incorporated into artificial membrane vesicles, either with or without a membrane potential.

There also remain important questions at the biological level. Why is the dual-start motif conserved in the two unrelated kinds of *S* genes? Granted, the threefold-lower burst size due to the accelerated onset of lysis in the M1L alleles could easily explain the selective advantage. However, it appears that the timing of lysis is even more sensitive to the steric properties of the amino acid side chains in the transmembrane domains (e.g., Ala-52) than it is to the presence of the inhibitor product. It would seem more economical to build another 5 to 8 min of lysis delay into the intrinsic clock rather than go to the trouble of evolving the dual-start motif. Intuitively, one would expect that under some conditions, production of the inhibitor form predominates explicitly to prevent lysis. Alternatively, the inhibitor may exert its negative effect only at total *S* concentrations below a certain level. A model favored for its simplicity is that the continuous accumulation of S105 and S107 in mixed aggregates in the membrane during the late-gene period causes a increasing leakage of protons. At some point, this leakage becomes unsupportable, resulting in collapse of the membrane potential and consequent formation of the holes. This scheme is inherently saltatory, allowing normal macromolecular metabolism to continue until just before the onset of lysis. In any case, in the remainder of this review, I shall present evidence that a similar strategy has been adopted by all phages which have evolved to elaborate a lysozyme activity for the purpose of liberation of progeny virions. That is, in each case there is a second gene encoding a holin. In contrast, the presumably simpler tactic of synthesizing a lysozyme with a canonical N-terminal secretory signal is used nowhere.

BACTERIOPHAGE T4

Overview

From the 1940s until about 1970, there were more papers on lysis phenomena of phage T4 (and its close relatives T2 and T6) than any other phage, but only a handful have appeared since 1980. The initial spate of activity was mostly due to the central roles of the study of the T4 latent period and the genetic analysis of the *rII* genes in the early development of molecular genetics (23). Lysis itself originally received attention because, to find out what was going on inside the cell after infection, fast and easy ways of disrupting the cell had to be developed. This led Delbrück (79) to the discovery of "lysis from without" by superinfection with excess T6 particles and Doermann (83) to the use of CN^- to induce premature lysis. Beginning with Hershey's (140, 141) genetic analysis of the *r* plaque morphology mutants of T-even phages, mutations in no fewer than 11 separate T4 loci have been implicated in lysis or lysis regulation. Streisinger et al. identified and purified a soluble mureinolytic enzyme, the T4 lysozyme, and showed it to be essential for T4-induced lysis (282). Stent and Maaloe (281) and Watson (302) published work dealing with lysis inhibition and lysis from without. Benzer's work on the fine structure of the *rII* genes is regarded as part of the foundation of molecular genetics (22). Despite this aristocratic pedigree, however, T4 lysis has been largely ignored during the molecular era. Even the relatively recent and comprehensive book *Bacteriophage T4* (203) contains almost nothing about lysis or its mechanism. Thus almost all the available evidence is from classical T4 genetics and bacterial physiology. In the following, this relatively aged body of data is summarized. With these observations in hand plus the perspective gained from the study of λ lysis, an attempt is made to derive a reasonable model for T4 lysis.

Lysis and Lysis Inhibition

Doermann's classic one-step growth curves for T4 phage revealed several crucial aspects of phage lysis (82). If cells are infected with T4 and diluted 10^3 -fold into aerated broth at 37°C, a lytic event at 27 min can be detected as occurring at the time when the free phage titer (in a sample filtrate or supernatant) suddenly increases to match the total phage titer (PFU present in a chloroform-treated sample). No phage are left in an intracellular (i.e., nonfilterable or sedimentable) form. For the purpose of this review and in keeping with the terminology of Kao and McClain (177, 178), I will use of term LI for lysis from within for this normal vegetative lysis. LI depends on the activity of the phage-induced lysozyme (282). However, if the phage lysozyme is not produced, respiration and metabolism cease at the normal lysis time, although no lysis is observed (225). LI can be triggered prematurely by anaerobiosis or energy poisons in the second half of the late-gene expression period (i.e., 20 min or later after infection) (83, 173). Lysis triggering can also be evoked by protein synthesis inhibitors, although the onset of lysis is significantly delayed compared with the CN^- -triggered event (83, 173). Thus far, lysis by T4 is obviously reminiscent of lysis by λ .

Unlike λ , the T4 phage particle has lytic activity itself (88). T4 virions, even if inactivated by X-irradiation, cause rapid lysis of the target cell when infected at very high multiplicities (>100 particles per cell) (79, 83, 302). Again, I will adapt the terminology of Kao and McClain (178) and designate this

as lysis from without (LO). Purified T4 virions have two different lysozymelike activities; one is adventitiously adsorbed lysozyme produced during late protein synthesis, and one is organic to the base plate structure of the virion tail (88, 177, 316). The latter activity is required for LO (177, 178, 224). Cells infected primarily at a low multiplicity develop an increasing resistance to LO beginning a few minutes after infection (87, 295).

Setting aside LO for the moment, one also finds that, with T-even phage, normal vegetative lysis (LI) has properties different from that in the lambdoid model. LI as described above is detected indirectly, by the appearance of liberated phage in very dilute infected cultures. Attempts to monitor LI with wild-type T4 at visible cell densities fail; cultures infected at a multiplicity of infection of 5 to 10 stubbornly refuse to lyse and continue to accumulate intracellular phage for extended periods (141). This phenomenon is called lysis inhibition (LIN) and is caused by absorption of one or more phage particles to the primarily infected cell (45, 82). Each secondary absorption event seems to cause a delay in lysis of 5 to 10 min or more (45). T4 plaques are small, with a turbid halo surrounding the cleared centers, reflecting the occurrence of LIN during plaque development (82, 140, 141). Liquid cultures at high cell density may show LIN for hours, because most of the infected cells are continuously absorbing progeny phage from a small fraction of the population which escapes LIN (82). LIN can be effected even in a culture midway down a lysis profile and seems to be an almost instantaneous process (45). It requires only a single secondarily absorbing phage but does not require gene expression of this phage, since heavy X-irradiation of the superinfecting particles has no effect (259). However, T4 ghosts, which are osmotically shocked, DNA-free virions that are lethal and capable of LO (139), are nonetheless incapable of causing LIN as the superinfecting agent. T2 and T6 can cause LIN of primary T4 infections, but superinfection with phage from outside the T-even family does not result in LIN (82).

An elegant framework for considering the evolutionary selections which shaped T4 lysis regulation has been proposed by Abedon (2, 3). His idea is that both the normal short latent period of T4 and the LIN system which can extend the vegetative cycle so dramatically are matching and complementary evolutionary adaptations. The rapid lysis characteristic of singly infected cells would allow T4 to spread through a virgin population of cells, albeit at a low burst size. Once infected cells dominate the population, LIN is established, permitting indefinite extensions of the latent period and extremely high progeny titers.

Historically, the LIN phenomenon proved to be amenable to genetic analysis because a mutation that inactivates LIN confers a distinctive plaque morphology: large, sharp-edged plaques easily detectable among the smaller wild-type plaques. In his classic papers, Hershey (140, 141) demonstrated that these plaque morphology mutants did not exhibit LIN in liquid culture and gave them the designation "*r*" (for rapid lysis) mutants. The original *r* mutants mapped to three disparate loci, *rI*, *rII*, and *rIII* (142). The most famous of these classes is the *rII* class, which consists of the adjacent *rIIA* and *rIIB* cistrons, a term invented for the occasion (22). In their famous experiments on the fine structure of the *rII* locus, Benzer and colleagues exploited the still unexplained observation that *rII* mutants do not form plaques on λ lysogens if the *rex* (for *rII* exclusion) locus in the prophage is functional (151). Infection of T4 *rII* into a *rex*⁺ lysogen is normal up to a point (about 10 min) just after the initiation of

T4 DNA replication, at which time there is an abortion characterized by a sudden cessation in respiration and a loss of small molecules to the medium (102), hallmarks of an inner membrane lesion. The other two classes of *r* mutations, *rI* and *rIII*, map to separate locations on the T4 genome and are not restricted by λ lysogens (22). In closing the historical overview, it should be noted that Champe (62), at the end of a review on phage reproduction published nearly 30 years ago, penetrated to the core of the lysis question: "The finding of the phage-induced lysozyme would have solved more or less the problem of lysis had there not existed the phenomenon of lysis inhibition . . . the results at least reveal what is probably the most pertinent remaining question of the lysis phenomenon: What causes a phage-infected cell to die metabolically?" His insight, made without a shred of molecular evidence, should be kept in mind as we attempt to construct a useful model for this complex event.

Genes and Molecular Mechanisms

Genes *e* and *t* are the main lysis genes, defined by the usual criterion that defects in either gene can prevent lysis without reducing the accumulation of intracellular phage particles (172, 282). The *e* gene was identified by Streisinger et al. (282), who noticed that the normally small T4 plaques would grow a halo if exposed to CHCl_3 vapor. It turns out that the halo was due to massive release of lysozyme activity at the borders of the plaque, which presumably is lined with infected cells in the LIN state. By mutagenizing, plating at a permissive temperature, and then screening for halo-negative plaques at the nonpermissive temperature, Streisinger et al. obtained temperature-sensitive *e* mutants (282). *e* encodes the T4 lysozyme which has been crystallized and subjected to detailed structural analysis (118). T4 lysozyme has a generally globular structure, with a diameter in the longest dimension of about 5 nm, and exists in solution as a 14,000- M_r monomer (70). The *e* gene does not encode a signal peptide, so the mature protein is identical to the predicted gene product (118, 291). Lysozyme activity accumulates intracellularly from the onset of late gene expression, at about 8 min after infection (62). Actually, the *e* gene is also transcribed early in infection, but translation is prevented by a stable secondary structure which occludes the ribosome-binding site for *e* in the early transcript (207). Transcripts from the *e*-specific late promoter, which is closer to *e*, lack the 5' sequences required for this inhibitory structure and are thus translated efficiently. There does not seem to be any real lysis regulation here, the early *e* transcripts apparently having no functional role in effecting lysis under any conditions.

t mutants were isolated by Josselin (172), who selected for mutant phage with the distinctive phenotype of λ *S* mutants: hyperaccumulation beyond the normal lysis time. The resulting amber mutants were found to define a complementation group mapping close to gene 38, a late gene encoding a tail protein involved in receptor recognition. (In an obscure allusion, *t* was named for Tithonus [172], who was the offspring of the dawn goddess, Aurora, and a Trojan prince. Tithonus was granted a diminished sort of immortality in that his eternal life was coupled with a withering away to the form of a grasshopper.) No *e* mutants were obtained, because, as in λ , defects in lysozyme do not affect the termination of the vegetative cycle and thus do not lead to hyperaccumulation of phage particles. T4 *e* has been shown to complement the lambdoid *R* (250); one of the two kinds of

R genes is evolutionarily related to *e* (47, 250); and the properties of T4 *t* and λ *S* mutants are similar (172, 173, 248). Therefore it was anticipated that there would be some recognizable similarities between *t* and *S* when the former became available for analysis at the sequence level.

Unexpectedly, however, this is not the case. The cloning and sequencing of the *t* gene from the closely related phage K3 has been reported (251). Like *e*, *t* has a consensus T4 late promoter just 5' of the putative Shine-Dalgarno sequence. The predicted *t* protein is slightly basic (pI 8.1) with a molecular weight of 25,000 and 218 amino acid residues. There is no detectable sequence homology with *S*, nor is the arrangement of charged, polar, or hydrophobic residues similar. The *t* gene encodes a single stretch of hydrophobic residues which might serve as a membrane-spanning domain (Fig. 8). In view of the surprising lack of similarity to *S* (and to other putative holin genes [see below and Fig. 8]), it is worth scrutinizing the evidence that this is really gene *t*. The DNA containing this reading frame was first identified by screening a pUC library of K3 DNA by colony hybridization with a gene 38 probe. Since 38 maps very close to *t*, positive clones were further tested for the ability to complement or rescue T4 *t* amber mutants. Only clones carrying parts of the 218-codon reading frame allowed recombination rescue of the T4 *t* amber mutants, and there were no other significant reading frames in the 0.8-kb sequence. This is strong evidence that the reading frame is in fact *t*, but there are some puzzling aspects to the data. First, no clones carrying the complete *t* were obtained, even in antisense orientation to the promoter on the pUC plasmid, nor were efforts to construct a complete clone from different partial clones successful. For those who have ever tried to clone lysis genes, this is a familiar story. pUC plasmids are of such high copy number that complete repression of the vector *lacPO* promoter is impossible, and the *t* gene is certainly expected to be a lethal gene. The implication is that at this copy number, even the low background level of transcription in the antisense direction leads to intolerable levels of *t* expression. The real puzzle, however, is the finding that incomplete clones, missing N-terminal or C-terminal residues and oriented in the sense or antisense direction (with respect to the vector promoter), are capable of "complementation," as judged by a 100% plating efficiency of the T4 *t* amber mutants on these clones. It is hard to see how a fragment of *t* can be defective enough to be cloned under constitutive expression conditions but functional enough to perform its lethal function during infection of the *tam* phage. Intragenic complementation between the *t* amber fragment products of the infecting T4 phage and the nonlethal, partial products of the complementing clones is unlikely, since at least one of the *tam* mutations maps to the N-terminal one-third of the gene, as judged by the marker rescue data. A second report has appeared giving the sequence of the nearly identical T4 *t* gene (220). This report mentions that the sequenced fragment complements T4 *t* amber mutants. This finding is based on the observation that lysis was obtained by partial induction of a full-length *t* clone during infection with the T4 *tam* mutant (136).

Thus, despite the odd properties of the K3 *t* clones, it seems likely that the sequences reported are in fact *t* genes. We are left with the somewhat unsatisfactory conclusion that *t* and *S* seem to function in lysis in a highly homologous way without discernible similarity at the structural level. In contrast, genes thought to be functional homologs of *S* have been sequenced from such diverse sources as the virulent coliphage T7 and the gram-positive phages ϕ 29 and PZA,

and the predicted products, although as unrelated in sequence to λ S as was S²¹, have striking similarities to S in terms of size, potential transmembrane domains, and the arrangement of charged residues (Fig. 8; see below). Although it certainly would not be the first time that T4 stood alone, it would be reassuring to have absolute proof of the identity of *t*. One way to do this would be to use polymerase chain reaction technology to amplify short fragments of the *t* sequence directly from DNA of known T4 *tam* mutants. Since two *t* amber mutations have been mapped by the marker rescue data of Riede (251) to specific small regions of the *t* gene, only very small DNA fragments would have to be sequenced. Of course, since *gpt* has not been detected, much less localized to the membrane, it is also possible that *t* is different because it is not the holin at all. Instead, it may act upstream in the lysis pathway of the real T4 holin, which may have eluded genetic detection.

Linder and Carlson isolated T4 *rid* (rho interaction-deficient) mutants by screening mutagenized phage for those which could plate on a host with a mutant (polarity-suppressing) *rho* gene but not on the isogenic wild-type host (191). Surprisingly, *rid* mutations mapped to *t*, and in fact *tam* mutants displayed a *Rid* phenotype, with a plating efficiency of 0.01 to 0.06 on *rho* mutant hosts at 37°C (compared with 10⁻⁵ on the wild-type host). Moreover, the presence of a pBR322-derived plasmid carrying a 7-kb insert of *E. coli* DNA spanning the *rho* gene makes the otherwise nonpermissive *rho*⁺ partially permissive (plating efficiency up to 0.1 at 37°C) even for the T4 *tam* phage. Since *rho* is autoregulated and thus the intracellular concentration of Rho in the polarity-suppressing *rho* mutant is much higher than normal, the authors suggest that the permissiveness for the *rid* and *t* mutants in both cases reflects a high level of Rho protein, independent of the polarity-suppressing alteration in the *rho* mutant. These findings are hard to fit into a cohesive picture for *t*, especially since other hosts with wild-type *rho* loci (such as the familiar prototrophic strain W3110) (15) were completely permissive in terms of plating efficiency for the *rid* mutant tested. However, data on the accumulation of virions in the intracellular and extracellular fractions reveal that the *rid* mutants behave like partially defective *t* mutants: phage accumulation is normal but lysis is delayed in onset, gradual, and very inefficient in the wild-type hosts. In the polarity-suppressing *rho* host or in the host carrying the *rho* plasmid, phage intracellular accumulation is actually reduced (twofold or more), but phage release, although still delayed and inefficient, is increased somewhat, to about 50% of the total phage after 2 h of incubation. In the W3110 *rho*⁺ host permissive for the *rid* mutant, phage production is very high and thus even the limited, nonspecific release of progeny is sufficient for efficient plaque formation. The rationale that I favor is not that Rho and *t* interact but, rather, that the *rho* mutants, and the multicopy *rho* host, are sick and susceptible to nonspecific insults to the membrane inevitable during the depredations of a T4 infection. This may be an example of how unreliable plaque-forming efficiency is for assessing the function of the holin genes, since defects in holin function can be automatically compensated by the concomitant prolongation of progeny and lysozyme accumulation and by the nonspecific deterioration of the membrane. An old observation, that λ Sam7 plates with efficiencies up to 0.1 on *rho* mutants (8), may also be explained in the same way.

r and *rex* Genes

An excellent overview of the *rII* genes was published in 1983 (273), which stated the situation succinctly: "we have no satisfactory idea what the *rII* proteins do." The situation has not changed, even though both genes have been cloned, sequenced, and analyzed as to regulation of expression. For the record but without expectation of making a sensible story, I shall briefly restate what is known about *rII* gene function. The *rII* gene products have been identified by SDS-PAGE, *gprIIA* as an $M_r \approx 74,000$ to 94,000 species associated exclusively with the membrane fraction (90, 153) and *gprIIB* as an $M_r \approx 34,000$ polypeptide which fractionates about 80%-20% into the membrane and cytosolic fractions, respectively (153, 236, 306). In addition, the *rII* proteins copurify with membrane-depleted T4 replicative complexes (199) and bind to DNA-cellulose (155). Both genes are transcribed in the early phase of the T4 infective cycle and are subject to transcriptional and translational controls characteristic of dXTP and DNA synthesis genes (273). The sequence of the *rII* genes is not very illuminating. Although both proteins are associated with the membrane, there is no obvious potential transmembrane domain in the predicted sequences of the extremely hydrophilic 83K *rIIA* protein or the 35K *rIIB* protein (73, 154, 241, 270). There is very little similarity of either predicted protein sequence with anything in the sequence data bases, with the exception of one short segment of *rIIA* which resembles the helix-turn-helix motif in *OmpR* and another sequence which is similar to a short motif in *Tsr*. This short homology has led Daegelen and Brody (73) to suggest that the *rII* proteins may constitute some sort of two-component sensor-regulator. This is an attractive idea, given the instantaneous kinetics which characterizes the imposition of LIN regulation, but the lack of a convincing membrane-spanning motif and the general lack of similarity to the large family of two-component regulators makes it highly speculative at best. By this time, the reader will not be surprised to learn that the pursuit of the *rII* phenomenon via analysis of the *rex* genes has also been largely a frustration. It turns out that the *rex* locus contains two adjacent cistrons, *rexA* and *rexB*, just downstream from and cotranscribed with the famous *cI* gene in λ (204). Both genes are required for the *Rex*⁺ phenotype. *RexA* may be a membrane protein. Strangely, overproduction of *RexA* in the presence of limiting *RexB* is lethal, but not overproduction of both genes at a normal ratio or either gene alone (278). The associated lethality is characterized by the same membrane lesion phenotype as is the *Rex*-mediated abortive infection of T4 *rII*. Interestingly, Shinedling et al. (269) showed that transcription of the *rex* locus on a multicopy plasmid makes the host restrictive for wild-type T4, implying that the T4 *rII* mutants are merely more sensitive to the *rex* block. The possible relationship between these *rex*-associated phenomena and the reported *rex*-mediated effects on λ lysis timing (254) has not been explored.

Finally, nothing has been heard about the *rI* and *rIII* genes in the decades since their discovery and mapping. Lacking any information on these genes, I have chosen to ignore them in formulating the following model.

Model for Lysis Inhibition

Assuming that the reported sequence of *t* is correct, we might conclude that the surprising dissimilarity between *S* and *t* reflects the latter's susceptibility for *r*-mediated LIN. The implication is that LIN operates at the level of inhibiting

t function, a notion which is supported by some indirect evidence. If we suppose that *t* functions analogously to *S* in forming a hole in the inner membrane at the end of late-protein synthesis, the available data from studies on the kinetics of LIN suggest that inhibition occurs only in cells in which "t-holes" have not yet been formed (45). In *t*⁺ *e*⁻ infections subjected to a single superinfection and thus a limited period of LIN, *t*-dependent cessation of respiration is delayed by the same period that lysis is delayed in a *t*⁺ *e*⁺ infection under the same LIN conditions (225). Moreover, the instantaneous nature of the LIN effect suggests that the inhibition is transmitted as a direct result of a membrane perturbation, presumably associated with the events involved in the pathway by which the secondarily absorbing phage attempts to inject its DNA into the host cytoplasm (45, 259). Also, it has been reported that infected cells in the LIN state can be triggered to lyse with CN⁻ (173). Again, with the *S* story as background, one is drawn to the speculation that the *r* complex somehow directly controls *t*-hole formation from *t* oligomers. That is, the *r*-mediated inhibition of lysis must act at the level of *t* function since it can be subverted by CN⁻ triggering.

rII mutations, including total deletions, have been found to suppress *tam* mutations (173). This does not seem consistent with the model presented above, but close examination of the data suggests otherwise. The observation is that a T4 *ΔrII* double mutant makes tiny plaques and releases phage from cells infected in liquid culture, whereas T4 *tam* does neither. However, the release of phage in the double mutant begins late and is exceedingly slow, and even after 90 min, only about 10% of the accumulated phage have been liberated. The fact that this partly suppresses the plaque-forming defect again reflects the characteristic of *t* (and *S*, in λ) mutants that everything is overproduced. Thus the apparent "suppression" of the *tam* defect is probably an indirect effect. That is, the *t* defect leads to hyperaccumulation of phage particles in the cytoplasm and numerous T4-encoded proteins in the membrane (91, 153) during the extended vegetative phase. This, in addition to numerous other T4 depredations such as total dissolution of the host genome, leads to nonspecific membrane lesions, leakage of lysozyme, and subsequent release of enough phage in each cycle to cause a small plaque.

Although it is nice to have a model which can rationalize the available data, it must be reiterated that this scenario is highly speculative and totally lacking in molecular evidence. In reality, the entire *t*-mediated, *r*-controlled lysis phenomenon remains shrouded in mystery, all the more vexing in light of how long this event has been available for genetic analysis and also, perhaps more embarrassingly, how intimately related it is to some of the definitive and founding experiments of molecular genetics. In the following, I will attempt to review, and set aside, phenomena such as LO that are probably or definitely not associated with real T4 phage lysis. All of these phenomena have been suggested at one time or another as being involved in the regulation of normal vegetative lysis, and it is my contention, as well as fervent hope, that this is not true.

Lysis from Without

The most prominent phenomenon which has complicated our thinking about T4 lysis is LO. Mutations in gene 5, which encodes a baseplate protein, abolish the ability to cause LO (178), and mutations in gene *sp*, or "spackle," abolish the ability to establish the resistance to LO (87). These genes

have a tortuous history. Gene *sp* was originally identified as a site which could be mutated to suppress the non-plaque-forming phenotype of an *e* nonsense or deletion mutant (87). Some of the pseudorevertants map to *sp*, and the others map to 5 and include alleles which are also temperature sensitive for 5 baseplate function (87, 177, 178). These 5 mutations cause lysis of singly infected cells, in the absence of *e* function and irrespective of whether baseplates are actually assembled (177). In fact, the lysis of *e* 5 mutants also defective in baseplate assembly is somewhat faster than when baseplate assembly is normal, suggesting that free gp5 is involved in the lysis event. Moreover, these altered function 5 mutants can cause LO even after primary infection with wild-type T4; that is, these 5 alleles can overcome LO resistance (178). The simplest model is that gp5 is responsible for the lytic activity which is intrinsic to the virion (88) and probably acts to cause localized degradation of the murein layer during the infection process. Infection with large numbers of phage leads to gp5-mediated LO. This notion is supported by the recent sequence analysis of gene 5, which demonstrated that a true lysozyme domain exists within the reading frame (224). The lysozyme activity may require a proteolytic cleavage for activation. Another recent finding is that gene *sp* turns out to be gene 40, which encodes a membrane protein involved in capsid morphogenesis (230). The membrane location of gp40 makes it possible to rationalize the additional function of inhibiting the gp5-mediated LO. This allows a unified model for LO and for the *sp*- and 5-mediated suppression of *e* defects. In this model, gp40, at least some of which is present as a transmembrane protein with a periplasmic domain, inhibits periplasmic 5-encoded lysozyme activity, perhaps by preventing its proteolytic activation. The gp5 lysozyme activity is delivered to the murein layer in the periplasm either by infecting phage from outside or by leakage through *t*-holes from inside the cell. The leaked gp5 activity would be at such a low level that it would be detectable only under *e*⁻ conditions and might be expected to be an inefficient mechanism to degrade the cell wall. In fact, T4 *e sp* double mutants, although plaque forming, release only 10% of the assembled phage (87). A prediction of this model is that either *e sp* or *e 5* plaque-forming pseudorevertants would depend on *t* function. Unfortunately, no data on *e sp t* or *e 5 t* triple mutants are available. In the absence of this direct test, one might expect that, if *t*-holes are required for this kind of suppression of *e* defects, *e sp* and *e 5* pseudorevertants would show LIN. This point is controversial. Emrich reported that an *sp* mutation abolishes LIN (87), but Kao and McClain found that both *sp* and the 5^{ts} suppressor mutations show significant LIN, with lysis not beginning until 100 to 140 min after infection (178). The conflict may be technical, since Emrich's infections were done in a way that even the wild-type infection showed minimal LIN, with lysis onset at 80 min, and no *r* mutant control was provided (87). Under the conditions used by Kao and McClain, an *r* mutant showed lysis onset at about 30 min, as expected, and the wild-type infection had not caused lysis even at 4 h. The intermediate phenotype of the 5 and *sp* mutants suggests that LIN was established, thus implicating *t* in the lytic event, but then was subverted, presumably owing to a nonspecific membrane insult associated in both cases with a derangement of the process of particle morphogenesis. Alternatively, the subversion of the LIN state in *e sp* or *e 5* infections may simply reflect LO brought about by the baseplate lysozyme of the secondary phage running amok (1). In any case, it seems that gene *sp* is expressed early in infection for the important dual

functions of limiting gp5-mediated murein degradation associated with the injection process of the initial infection and protecting against secondary phage. Thus the accumulation of functional *gppp/40* in the membrane may in fact constitute the establishment of LO resistance. Altered 5 protein in the baseplates of T4 5^{ts} mutant secondary phage could elude the inhibition of the wild-type *gppp* and thus cause LO (178).

Phospholipase Activity

Free fatty acids (FFA) accumulate in the membranes of T4-infected cells, raising the possibility that phospholipase activity is involved in cell lysis (71). However, Josslin found that inhibition of gross phospholipase A activity by infecting the cells in the presence of EDTA (to chelate Ca²⁺) eliminates the accumulation of FFA without affecting lysis (174). Moreover, if the host lacks both the DR (detergent-resistant) and DS (detergent-sensitive) phospholipase activities, the release of T4 particles is normal (125). However, the FFA accumulation associated with T4 infection does require *t* function, suggesting that activation of phospholipase activity is a by-product of the t-hole formation (174). Interestingly, rapid FFA accumulation occurs during T4 *rIII* infections prior to lysis (21). This suggests that severe membrane insults occur in these infections before t-hole formation. Moreover, excessive FFA accumulation in the cytoplasmic membrane might be expected to be incompatible with maintenance of the membrane potential and thus could contribute to the triggering of *t* function.

Star Mutants

Star (*st*) mutants are so designated because of a peculiar plaque morphology—irregular plaques with sectors of clear lysis radiating from the center (140, 206, 285). The sectors are caused by secondary mutations in the *r* genes. *stI* has not been characterized beyond mapping (184). *stII* is *t* (185). Mutants with mutations in *stIII* arise as pseudorevertants to tight non-plaque-forming *stIII* (*t*) mutants (186). In T4 *stIII* infections of *E. coli* K-12 in liquid culture, phage are gradually released beginning about halfway through the normal vegetative cycle, even when the cells are coinfecting with *stIII*⁺. Although single-step phage release measurements seem to suggest that the *stIII* mutation also partially suppresses an *e* defect, *stIII e* double mutants do not form plaques (186). No more information has appeared on *stIII* since its original description. The limited information available suggests that the *stIII* lesion may cause a severe membrane perturbation leading to gradual deterioration of envelope integrity, rather than affecting lysis regulation directly.

LYSOZYME-INDEPENDENT LYSIS SYSTEMS: ϕX174 AND MS2

Host Autolysis and Liberation of Bacteriophage

To this point, the phage lysis systems we have reviewed require, in the normal process of releasing the progeny virions, the participation of a phage-encoded enzyme which degrades the murein (i.e., *e*-lysozyme or *R*-transglycosylase). This section deals with bacteriophage which accomplish lysis and progeny release without the participation of such phage-encoded activity. Formally, this means that either murein degradation is not required in these cases or host enzymes are recruited for this purpose. In *E. coli*, there

are nine different enzyme activities which can attack bonds in the peptidoglycan, and these have been reviewed thoroughly by Höltje and Tuomanen (148). These enzymes are muramidases and amidases, which cleave the β(1→4) glycosidic linkages and cross-linking amide bonds, respectively. Oddly, none of the muramidases turn out to be true lysozymes but instead are transglycosylases, which yield a cyclic 1,6-anhydromuramic acid as the cleavage product. Höltje and Tuomanen suggest the term lytic transglycosylase for this activity to distinguish it from the biosynthetic transglycosylases which polymerize the murein precursors. There are two well-characterized enzymes, a soluble 65K lytic transglycosylase and a membrane-bound 35K lytic transglycosylase, encoded by the genes *slt* and *mlt*, respectively. The two murein-hydrolyzing amidases, or, more properly murein DD-endopeptidases, are a membrane-bound, penicillin-binding 49K species encoded by *dacB* (182, 202) and a soluble, penicillin-insensitive 30K species encoded by *mepA* (181, 289). A mutation in a third locus, *mepB*, also causes a reduction in the penicillin-insensitive murein amidase activity, for unknown reasons (159). As a background for considering the mechanism of phage lysis, one would like to know how these activities are regulated in the uninfected cell. Unfortunately, the genes for these activities appear to be individually dispensable, indicating that, if there is an essential physiological role for these enzymes, significant redundancy must exist in the system. This has complicated genetic analysis, with the result that little is known about regulation of these activities, and although attractive models have been proposed, it is not known what role they have in murein biosynthesis (235).

In *E. coli*, autolysis can be induced by a number of biochemical or physiological insults, which Höltje and Tuomanen have grouped into two general classes: nonspecific chemical or physical activation of autolysis (i.e., osmotic shock or EDTA-treatment), and autolysis resulting from inhibition of murein synthesis (i.e., by treatment with β-lactam antibiotics or starvation for diaminopimelate). In general, autolysis phenomena of the second class depends on cell growth. Stresses of various types, including the stringent response to amino acid starvation and heat shock, appear capable of modulating the activity of cellular hydrolases. In addition, growth at low pH (pH ≤ 5) prevents penicillin-induced lysis, although not against the distortions of cellular morphology associated with the effective binding of β-lactams to their target molecules. This effect is not understood, but the pH dependence is also shared by inducible lysis systems in which the lysis genes of MS2 and ϕX174 have been cloned under the control of strong promoters (see below).

If a phage uses the host autolysis machinery for lysis, there should be at least one phage gene for which mutations will confer a nonlytic phenotype and affect plaque formation. Ideally, this gene would be lethal when expressed in the absence of other phage functions, so one could easily get host mutants resistant to its function. To establish a connection between phage lysis and the host autolysins, one would hope to get mutations in the autolysin genes which would confer such resistance, but this has not yet been accomplished although the lethal lysis genes of two different lysozyme-independent phages (ϕX174 and MS2) have been cloned. (Host mutants resistant to the lethal action of the ϕX174 lysis gene *E* have been obtained, but the mutant gene does not encode an autolysin [see below].) It is important to note, however, that such mutants can be isolated by direct selection only if the murein degradation step is the lethal step

in the lytic pathway. Since this is certainly not the case for λ lysis, in which the lethality is conferred by the *S* gene, not the *R* gene, it may be that the failure to isolate such mutants simply indicates that there is a lethal membrane effect preceding and not requiring autolysis. Alternatively, it may be that phages requiring autolysis can utilize the full spectrum of redundancy indicated by the lack of phenotype for the mutants in the individual murein hydrolase genes. In any case, as the reader will see, this means that evidence for involvement of host autolysis functions is invariably based on indirect physiological experiments.

One recent report did present genetic evidence for an intimate relationship between autolysis and phage development. A *ts* mutation in a locus designated *lytD* was shown to undergo autolysis at the restrictive temperature (74). Surprisingly, when a phasmid library was used to suppress the lethal phenotype, the complementing clones were shown to contain the *cI-cro* region of phage λ , apparently from λ helper phage contaminating the phasmid preparation. This result was interpreted as showing that *lytD* encodes a repressor which controls the expression of autolysis genes and that the operator sequence recognized by the putative *LytD* repressor can also bind the *cI* and *cro* repressors. Another interpretation is possible. The lysis profile associated with shifting the *lytD^{ts}* mutant to 42°C is identical to the sharply defined lysis profile associated with the induction of a λ lysogen. Moreover, the *lytD* mutation was found fortuitously after transposon mutagenesis by using a λ *att⁻int⁻* vector as the transposon donor, and the mapped location of *lytD* is at 12.7 min, where there is significant homology between the λ genome and a fragment of a cryptic lambdoid prophage (249). These considerations suggest that *lytD* may be a thermosensitive λ prophage integrated by homology-dependent recombination at the cryptic prophage site and accidentally selected during the transposon mutagenesis step. This explanation seems more easily defended than the notion that the *cI* and *cro* repressors of λ can recognize and repress the operators served by the putative *lytD* repressor but that the latter could not bind the λ early operators, since *E. coli* is not constitutively λ immune.

BACTERIOPHAGE ϕ X174

Overview

Because of its small size, single-stranded DNA genome, and capability for transfection, the study of the ϕ X174 infective cycle was particularly intense in the early 1960s. It was noticed early that, unlike λ and T4, ϕ X174 seemed to accomplish host lysis without elaborating a lytic enzyme like a lysozyme (86, 201). The significance of this was clear to Hutchison and Sinsheimer (156): "The mechanism of release of ϕ X174 by infected *E. coli* is of interest since its understanding must result in the discovery of either a phage-specific lytic enzyme . . . or a novel method of phage release." The latter turns out to be the case, since ϕ X174 has been found to have a single lysis gene, *E*, and its product does not have murein hydrolase or any other enzymatic activity. The function of gene *E* in host lysis has been the subject of a recent review by A. Witte, W. Lubitz, U. Bläsi, and colleagues (310), from whom most of the progress in this area has come during the last 10 years. Here I shall try to place the recent work in the context of classical ϕ X174 biology and in comparison with other phage lysis systems.

ϕ X174 Lysis Physiology

Infections of ϕ X174 can be made synchronous by absorbing the phage particles to the host cells in the presence of cyanide and then diluting them into fresh medium. At 37°C, an infected broth culture will grow for about 21 min and then undergo lysis, liberating 100 to 200 phage particles per infective center (Fig. 1B) (81, 157). Although the distinction might seem subtle, it is clear that the lysis profile is much broader (i.e., lysis is more gradual) than with λ . It takes about 7 min for half of the A_{550} to be lost, and the period of phage release, as determined by the traditional phage one-step growth curve, spans from about 14 min to past 30 min (81). In minimal medium, where the generation time of the host is increased to 70 min, lysis begins at about 70 min and requires nearly 1 h for completion (156, 201). Hutchison and Sinsheimer (156) demonstrated elegantly that single-cell lysis events span less than 1 min, so the breadth of the lysis profile reflects a gradual entry of the infected-cell population into the lytic process. The impression is that host lysis requires or may be partially coupled to cellular growth and/or cell division. This impression is reinforced when one adds an energy poison to the infected cells during the lysis event. In stark contrast to the λ and T4 lysis systems, the ϕ X174 lysis profile abruptly stops and cells not already lysed are effectively spared as long as the block in culture growth is maintained (Fig. 1B) (258).

During the 1960s, the lytic pathway of ϕ X174 and the closely related (but broader-host-range) phage α 3 was studied at the physiological and biochemical levels by several laboratories. Markert and Zillig (201) demonstrated that ϕ X174 lysis can be abolished by addition of chloramphenicol as late as 12 min after infection, after which a "lytic principle" begins to accumulate and lysis becomes increasingly insensitive to the drug. However, no lysozyme activity, assayed as the capacity for degradation of cell wall preparations, could be detected at any time. The lytic principle accumulates with about the same kinetics as do intracellular phage particles. Inhibition of DNA synthesis with fluorodeoxyuridine after 10 min, although eliminating phage particle production, does not affect lysis significantly. Lysis and phage particle release can be substantially prevented by the addition of sucrose to 20% (w/vol), Mg^{2+} to 0.2 M (note that this is a much higher level of divalent cation than is needed for the *Rz⁻* phenotype in lambdoid phage [61, 323]), or spermine to 0.01 M. In each case a significant hyperaccumulation of phage particles is observed (119, 201). These may be fundamentally different events, since the sucrose-stabilized cells maintain rodlike cell morphology, whereas the Mg^{2+} -stabilized cells eventually assume a spherical shape. Examination of ϕ X174 (258) or α 3 (50) infections by phase-contrast microscopy reveals that most infected cells undergo a common and distinctive series of morphological changes during the lytic event. First, cells develop small, phase-dark spherical bulges or blebs which emerge from the cell midpoint, presumably at a septal site. This bleb grows until it is approximately as large as the summed volumes of the residual rod-shaped portions of the cell, which are bent back at nearly right angles to the original axis of growth (Fig. 2C and Fig. 9; also see plate I of Bradley et al. [50]). These forms can be stabilized by any process which inhibits growth, including treatment with energy poisons or anaerobiosis (258). Eventually, the spherical body is freed, leaving an empty, broken ghost, presumably corresponding to the sacculus. The spherical bodies become less refractile, either gradually or catastrophically, leaving barely

visible membranous debris. Thus, unlike cells lysed by λ , in which the murein hydrolase activity rapidly destroys the sacculi completely, ϕ X174 lysis leaves behind large debris, including empty ghosts, with the bulk of the envelope undisturbed (50, 201, 258). Bradley et al. conducted systematic electron-micrographic studies on samples withdrawn for fixation and embedding at various times after infection by α 3 (49, 50). Beginning at about 14 min, small lesions (50 to 200 nm in diameter, as judged from the micrographs) in the cell wall begin to appear, mostly near the midpoint or incipient septal regions of infected cells (Fig. 9). Bulges (or blebs) are seen emanating from these lesions. As reconstructed from the time series of electron micrographs, some of these blebs burst and allow phage release, but most of the lesions widen to about 1 μ m in diameter. Substantial numbers of spheroplasts can be seen, apparently after escape of a sac, which contains the entire cytoplasmic contents and is bounded by the double membrane, through the large cell wall lesion. These workers concluded that most infective cycles of ϕ X174 and α 3 were fated to end with the cytoplasmic membrane bursting because of the loss of a localized but rather large section of the rigid cell wall. A few bursts occur at the small-lesion stage, but these are seen mostly in the samples taken at early time points and are judged to be premature lytic events by the authors. Unfortunately, these electron micrographs are not accompanied by any statistical data on the distribution of the various morphologies, and it must be remembered that the fixation and embedding processes might be quite harsh for cells in the process of lysis. An interesting comparison is provided by way of a similar series of thin sections prepared for uninfected cells undergoing penicillin-induced lysis. Similar morphologies are observed, although the initial small lesions are found randomly on the surface of the cells, not localized to the septal areas as in the phage-infected cells. Nevertheless, the impression is received that the integrity of a localized region of the cell wall is subverted during the process of ϕ X174 lysis. The failure to detect lysozyme activity might thus reflect the fact that any such activity is tightly bound to or perhaps even intrinsic to these localized sites (i.e., deranged features of the cell wall elongation machinery).

Lubitz and Plapp (193) assessed peptidoglycan biosynthesis during ϕ X174 infection by measuring the incorporation of labeled diaminopimelate into SDS-insoluble cell wall material. They observed that accumulation of counts in insoluble form was unaffected, compared with that in the uninfected cells, for about 10 min after addition of phage (at a multiplicity of infection of 5), but that counts were then actually lost continuously until +35 min (the lysis onset time under these conditions), indicating actual degradation of the newly synthesized murein. Chromatographic analysis of muropeptides prepared from lysozyme digestion of the washed sacculi suggested that both amidase and muramidase activities had been at work on the murein in the infected cells. Since such autolysin activities are thought to be enriched in the

central growth zones of the cell envelope, the site where the ϕ X174 envelope lesions had been reported, the authors speculated that ϕ X174 acts by activating the host autolysins in these regions. No muropeptide analysis was done on cells infected with lysis-defective mutants of ϕ X174 (see below), however, nor on cells subjected to mechanical breakage, so these data do not help discern whether the murein changes are a cause or a result of lysis. Moreover, the same authors later showed that ϕ X174 particles directly stimulate the solubilization of recently incorporated DAP in an *in vitro* system by using cell fragments prepared by mechanical disruption, raising the possibility that the apparent autolysin activity may be important to infection but irrelevant to lysis (194).

E Gene Structure

Early analyses of collections of *ts* and amber mutants revealed a single complementation group, designated *E*, with a phenotype defective solely in lysis (157). Infection of a nonsuppressing host with an *Eam* mutant (UAG in codon 4 [Fig. 10]) was shown to cause a rapid loss of cell viability despite a severalfold increase in culture mass. Microscopic examination reveals that the infected cells cease dividing and become elongated, with many becoming bent or otherwise malformed (157). Phage particles accumulate to more than 10-fold over the normal burst, but less than 1% of this huge yield is liberated. A decade later, at the dawn of the era of DNA sequencing, the sequence of the ϕ X174 genome was determined (19). Gene *E* was elevated at least temporarily above the obscurity customary for lysis genes when it became the first gene shown to be completely embedded within another (the maturation gene *D*) in a different reading frame (Fig. 10) (19). Thus single-base changes which confer only a lysis phenotype on ϕ X174 are also required to be silent in the *D* reading frame, and deletions with only a lysis defect are impossible. The *E* gene encompasses 91 codons, and the predicted molecular weight of protein *E* is 10,500 (Fig. 8B). On the basis of the algorithm of Garnier et al. (103) for secondary structure prediction, Witte et al. define four domains within *E*, including the N-terminal putative transmembrane domain and three complex structures in the hydrophilic C-terminal two-thirds of the molecule (310). Each of these domains is separated from the others by predicted beta-turn regions. I find this less than compelling, since there is no evidence that such algorithms, based on empirical secondary structure data from crystal structures of soluble proteins, are reliable for membrane proteins. Looking for help by homology, one notes that the amino-terminal one-third of the *E* protein and the λ S protein have certain similarities (Fig. 8). There is a potential membrane-spanning domain at about the same relative location from the N terminus of both proteins. For both proteins, the C-terminal boundary of the putative transmembrane domain would be marked by two basic residues and beta-turn residues (i.e.,

FIG. 9. Morphologies of *E*-mediated lysis. (A and B) Scanning electron micrographs of cells lysed by a cloned ϕ X174 *E* gene expressed from a p_L promoter. (C to J) Transmission electron micrographs of thin sections from cells lysed by the cloned *E* gene (panel C) or from cells infected with the closely related phage α 3 (panels D to J). In panels A and B, blebs can be seen emanating from the transmembrane tunnels situated at or near septal sites. Bars, 100 nm and 1 μ m in panels A and B, respectively. In panel C, the arrow indicates a tunnel in cross-section. In panel D, an early morphological change in the infected cell is seen as a pulling away of the cytoplasmic membrane from the cell wall. In panel E, a bulge is seen growing from the septal region of the infected cell. In panels G and H, a small bulge and an equivalent hole are seen. In panels I and J, large bulges with disrupted outer membranes are shown. In panel F, the empty sacculus with a septal lesion is shown. In panels E and I, P designates intracellular phage particles. Panels A to C reproduced from reference 313 with permission; panels D to H reproduced from reference 50 with permission; panels I and J reproduced from reference 49 with permission.

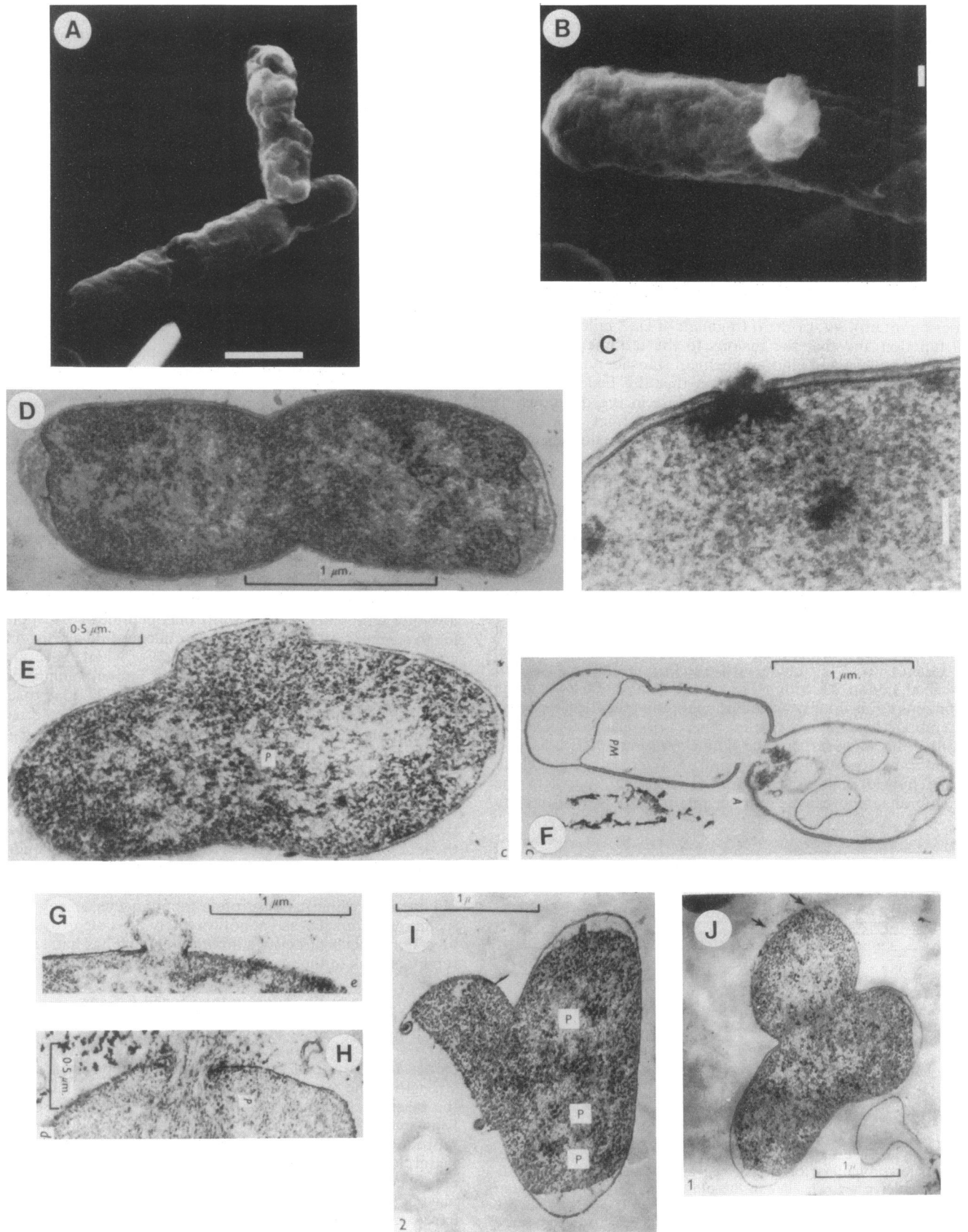

broth culture. Chloramphenicol added as late as 45 min after induction prevents lysis, but addition at 60 min actually accelerates the onset of lysis, and addition at later times has no effect. Low-level constitutive expression from the *tet* promoter in the same plasmid was tolerated by the cell, but many bizarre cell morphologies could be detected, including "two-headed" rods, indicating a partial derangement of cell division and/or cell wall metabolism (319). Bläsi et al., using *E* cloned under p_L control in a pBR322-type plasmid, obtained lysis within 10 min of thermal induction (38). These authors reported that similar induction of a fresh stationary-phase culture did not result in lysis but that dilution of the induced stationary culture even into repressing conditions (i.e., 28°C) restored a lytic outcome after about 45 min of aeration. In addition, the presence of chloramphenicol or rifampin in the dilution medium led to the immediate onset of lysis, albeit slow and incomplete. These data were interpreted as suggesting that lysis requires not only a certain level of *E* expression but also continuing cellular growth.

Regulation of *E* Expression

This section must be prefaced by saying that there is little expectation and less evidence that *E* expression is actively regulated at all. Transcription in ϕ X174 infections is unidirectional and constitutive from three promoters (Fig. 10), and all transcripts so far detected contain *E* (134). Consequently, attention has focused on whether *E* is translationally regulated. The major question, still unresolved, is whether translation of the "host" gene *D* affects translation of the embedded gene *E*, either positively or negatively. All of the work on this issue has been done with segments of the ϕ X174 genome inserted into plasmids and expressed from an inducible promoter, either under λ *cI* or *lacI* control. Buckley and Hayashi, using translational fusions with efficient ribosome-binding sites fused at various sites in the upstream *D* sequence, found evidence that certain stretches of the *D* gene are frameshift prone (54). They postulated that frameshifts at appropriate distances upstream of *E* lead to out-of-frame termination events that, in turn, potentiate *E* translation through either translational coupling or disruption of an inhibitory secondary structure in the mRNA. However, it is not clear how much of the effect on *E* translation is due to secondary structure differences between the constructs or how comparable the ribosome density on the *D* fusion constructs is to the ribosome density on *D* in the infected cell. Bläsi et al. found that the *E* translational start is intrinsically weak and surrounded by secondary structure, as judged by toeprinting assays with purified mRNA and 30S ribosomes (42). Moreover, the expression of *E* Φ *lacZ* fusions was independent of the level of translation of the surrounding *D* sequences. However, the toeprinting results must be viewed with caution, since these data are derived from a static system, in the absence of *D* translation. In addition, the fusion gene results are subject to the same limitations as those mentioned above. This issue will probably remain unresolved until the experimental context is returned to the complete ϕ X174 genome. That is, it will be necessary to alter the ribosome-binding site of *D* carefully (to avoid major changes in the overall structure of the mRNA) and then assess directly the production of *E* in the infected cell. Even then, it will be crucial to monitor the stability of the *D/E* mRNA before concluding anything about whether *D* translation affects *E* translation. In any case, the take-home lesson will still be the same: *E* is produced in small amounts, relative to *D* and to other ϕ X174 proteins.

Given that *E* is made in small amounts, one would like to know approximately how many molecules are required for lysis. One attempt at actual quantitation of *E* production was made with parallel inductions of plasmid clones of *E* and *E* Φ *lacZ*. By measuring β -galactosidase activity present in the fusion gene clone at the time that the intact *E* clone caused lysis, Maratea et al. (200) estimated that approximately 100 to 300 *E* molecules were required for lysis, a level consistent with that calculated from labeling data of Pollock et al. (237). This assumes, of course, that the *E* and *E* Φ *lacZ* genes are expressed at the same level (i.e., that the distal fusion joint does not distort the translation rate or the stability of the mRNA). Also, it should be noted that this was done in the absence of other ϕ X174 gene expression. Henrich et al. (138) found that an uninduced plasmid clone of *E* under *lacI* control in *E. coli* C was capable of partly complementing the plaque-forming deficiency of ϕ X174 *Eam*. They concluded that this suggests that, although no other phage gene is absolutely required for lysis, another ϕ X174 gene may amplify or potentiate the lethal action of *E*, so that sublethal basal expression of *E* in the uninfected cell may be sufficient for lysis in the cell infected with ϕ X174 *E*. However, this inference must be treated with caution, since the complementation cited amounts to only a 3% efficiency of plating, a level which might also simply reflect recombinational marker rescue in the *Rec*⁺ host.

Two ϕ X174 genes have been suspected of collusion with *E*. Gene *K* encodes a membrane-bound 6.4K polypeptide, in which defects lead to small plaques and reduced phage production (108). Interestingly, constitutive expression of *K* from a plasmid clone leads to delayed lysis after infection and an increased burst size, suggesting that *K* may act to inhibit the action of *E* (43). However, expression of both *E* and *K* together from plasmid vectors, in the absence of the other phage genes, did not affect *E*-mediated lysis. Moreover, Gillam et al. (108) reported that the *Kam* mutation did not affect the latent period, although no lysis profiles were provided. There is also an old report that a ϕ X174 *H* mutant showed delayed lysis (274), but thus far, no molecular analysis of *H* has been reported beyond its assignment to the capsid spike structure. Therefore there is still no compelling evidence that any ϕ X174 gene other than *E* participates in lysis. However, some differences have been reported in the cellular morphologies associated with the lysis events mediated by plasmid *E* clones and ϕ X174 phage infection (see below).

Host Genes Involved in *E* Function

The ability of *E* clones to support inducible cell lysis has allowed the search for host genes which could be mutated to *E* resistance. This is easily done by simply selecting for survivors after induction and discarding any mutants which have a defect in *E* expression or plasmid maintenance. Thus far, *E* resistance mutations have been found only in a single locus, which we call *slyD* (sensitivity to lysis) (200). All *slyD* alleles are recessive, some confer a slight retardation of growth in rich medium, and at least one, the *slyDI* allele, confers absolute resistance even if *E* is cloned under strong promoters on plasmids with very high copy numbers (258). Infection of *E. coli* C *slyD* with wild-type ϕ X174 results in a nonlytic vegetative cycle, resulting in hyperaccumulation of phage particles intracellularly and elongated cell morphologies, often doublet cells with obvious septal defects. Similar morphologies were shown by Hutchison and Sinsheimer for ϕ X174 *Eam* infections of nonsuppressing cells (157). Plas-

mids carrying *E* and *lacZ* in tandem, or any *E*Φ*lacZ* fusion, under the control of *lacP* have normal levels of β-galactosidase activity during induction, demonstrating that *shyD* mutations do not affect the expression of *E* at the transcriptional or translational level (200). *shyD* maps to 72.8 min, near the *crp* gene. A 1-kb segment of DNA from this region has been isolated by mini-Mu cloning, shown to complement the lysis defect, and subjected to sequence and genetic analysis (258). This fragment contains two genes that are normally cotranscribed from a promoter not in the cloned sequence. The distal gene is *shyD*, since the proximal gene can be deleted without affecting the complementation, and the same sequence extracted from the spontaneous *shyD* mutants has various lesions within the distal open reading frame (ORF), including IS insertions and missense and frameshift mutations. The *shyD* gene is situated behind a very strong rho-independent terminator, and several lines of evidence indicate that it is apparently expressed at very low levels, perhaps only a few molecules per cell (258). Currently, we have no evidence addressing what the normal cellular role for *shyD* is, for the *E^R* mutants have no other phenotype. In preliminary experiments, overexpression of engineered clones of *shyD* led to an extreme filamentation phenotype, which is weak evidence that the gene may be peripherally involved in cell division. Remarkably, the lysis supported by the *E*Φ*lacZ* fusions is not blocked by the *shyD* mutations which abolish *E* lethality. This finding suggests that the *shyD* product is involved in some aspect of *E* oligomerization or targeting, which is apparently dispensable for the fusion-mediated lysis. The *shyD1* allele has been transduced to *E. coli* C and shown to abolish φX174 plaque formation in that host (258). This allowed isolation of spontaneous plaque-forming revertants on a *shyD* lawn. These φX174 *pos* (plates on *shyD*) mutants have been shown to plate with 100% efficiency on both *E. coli* C *shyD⁺* and *shyD* indicator lawns, albeit with a reduced plaque size of the latter (258). The first few *pos* alleles have proven to be single missense changes in the N-terminal domain of *E* (258). It will be interesting to see whether the *pos* suppressors show allele specificity for different *shyD* mutations, which would imply a direct interaction between the *E* and *shyD* gene products.

There have been other attempts to find host genes involved in *E* lysis. Wadle et al. (298) compared the lysis profiles of induced *E* plasmids carried in various genetic backgrounds and concluded that a number of host genes were involved in *E* function or influenced the sensitivity of the host cell. In particular, mutations in *fadR*, involved in the regulation of fatty acid degradation, increase *E* sensitivity. In addition, a strain carrying a mutation in *envC*, a gene thought to be involved in cell separation (235), and at least one additional uncharacterized and unlinked mutation was also found to be resistant to *E* function. This is difficult to interpret, since mutations in the *envC* locus are highly pleiotropic and no further characterization of the other locus, designated *rle*, has been provided. Another *E*-resistant host mutant, designated *L⁻* for its lysis defect, was isolated by Henrich et al. (138) but has not been mentioned since. In any case, these physiological studies do not allow us to discern whether any of these genes are directly involved in *E* lysis, especially in the absence of any data about the effect of these host mutations on the copy number or expression levels of the plasmid-borne *E* gene. Recently, in a survey of mutants known to have defects in various genes implicated in peptidoglycan metabolism and septation, Witte et al. (310) reported that lysis was delayed in a *dacB mepAB* triple mutant but not in a *dacB* mutant. Since the

difference between the triple and single mutants is reported to be a defect in the penicillin-insensitive murein DD-endopeptidase activity in the former (159), the implication is that *E*-mediated lysis normally proceeds via this autolytic activity, rather than the penicillin-sensitive murein amidase. However, differences in the rate of lysis, be this either a measure of the interval after induction before lysis onset or the slope of the lysis profile, are not easily interpretable without some direct information about *E* expression. Temperature-sensitive mutations in a gene called *lytA* render a broth culture resistant to lysis by D-cycloserine and β-lactam antibiotics and also to lysis by either φX174 infection or induction of a cloned *E* gene (192). This gene has been postulated by Harkness and Ishiguro (126) to be involved in the regulation of the cellular autolysis system. However, no data are provided on *E* expression, so it would be incautious to conclude that *lytA* is directly required for *E* function. Moreover, the *ts* mutants used were later shown to induce the stringent response at the nonpermissive temperature (187). Since nongrowing or starved cells are phenotypically resistant to *E*-mediated lysis anyway, there is no need to infer a direct link between *E* function and *lytA*, irrespective of the still-unknown function of the latter. The *rle*, *mepAB*, and *lytA* effects are charged only with having defects in the lysis profile of a liquid culture after induction of a plasmid-borne *E* gene. It should be emphasized that the failure to lyse the temperature-sensitive *lyt* mutant at the restrictive temperature does not result in increased intracellular accumulation of phage particles, suggesting that this host mutation does not prevent *E* lethality. In fact, none of these mutations confers genetic resistance to *E*, so even if these genes are involved in *E* function, the affected steps must be downstream of the lethal event. In *E*-mediated lysis, unlike in λ lysis mediated by the lethal *S* gene and the lytic *R* gene, lysis and lethality are not genetically separated, which makes it unlikely that any of the genes cited above are directly involved in *E* function. However, Young et al. (318) showed that expression of heat shock genes could prevent *E*-mediated lysis without affecting the kinetics of *E* lethality, thus separating lysis and lethality in a physiological sense. This makes it possible that there are elements in the *E* lysis pathway downstream of the lethal event and allows for the participation of genes other than *shyD*. The block to lysis in the presence of the heat shock response is intriguing. Recently, Powell and Young (240) showed that the heat shock response also blocked the lytic action of β-lactam antibiotics, which adds weight to the notion that *E*-mediated lysis and penicillin lysis proceed by similar mechanisms. However, the β-lactam lysis required the function of the five heat shock genes tested (*groEL*, *groES*, *dnaK*, *dnaJ*, and *grpE*), whereas the *E* resistance required only three (*groES*, *dnaJ*, and *dnaK*) and could be effected by the overproduction of GroES alone. Although these data are provocative, the pleiotropic nature of these genes makes it difficult to conclude anything about the common steps in *E* and penicillin lysis.

Molecular Mechanism and *E*-Holes

Witte et al. (311, 312) have investigated the nature of the *E*-mediated lesion by using a variety of biochemical and physical techniques. By using a plasmid with *E* under *p_L* control, a shift of a logarithmic culture from 28 to 42°C resulted in a rapid onset of lysis (within 5 to 8 min) and was 50% complete within another 7 to 10 min. Chloramphenicol added up to 1 min after induction, but not later, could

prevent lysis, extending earlier observations from our laboratory (319). This was interpreted as showing that newly synthesized *E* requires a lag period before causing lysis, but no data on the kinetics of chloramphenicol uptake or the shutoff of protein synthesis are provided to substantiate this conclusion. In support of this idea, the uncoupler 2,4-dinitrophenol was also shown to require a 3- to 5-min delay before halting lysis, suggesting that an energy-requiring step is involved in *E* function. Similar results were obtained with an *unc* mutant, even though cellular ATP levels are actually elevated upon addition of uncoupler, suggesting further that it is the proton motive force and not ATP that is required for *E* to act. Measuring tetraphenylphosphonium accumulation as a measure of membrane potential, Witte et al. (312) demonstrated that the potential is undisturbed up to the onset of lysis and, not unexpectedly, decreases rapidly thereafter. The same is true of the Na^+ and K^+ ion gradients and intracellular nucleotide concentrations. This suggests that whatever the lesion inflicted by *E* and the nature of the lag required between *E* synthesis and *E* action, there is no gradual deterioration of the membrane. Rather, there is a sudden collapse of membrane integrity concomitant with visible lysis. Moreover, at a time after the onset of lysis when 90% of the total β -galactosidase activity is found in the medium, only 5 to 10% of β -lactamase and alkaline phosphatase, two marker activities for periplasmic proteins, are thus liberated. This was interpreted to show that the lesions were of a *trans*-envelope nature, a tunnel from the cytoplasm directly to the outside, essentially sealed off from the periplasm. Another interpretation is suggested by the finding that the polar periplasm is not continuous with the bulk of the periplasm but is a separate and much smaller compartment, defined by ring-shaped zones of adhesion, or polar annuli (78). Lesions which resulted in the destruction of both inner and outer membranes at such polar sites could cause the quantitative release of cytoplasmic protein but the retention of most of the periplasmic marker activity, as observed previously (320).

A surprising picture of the *E*-mediated lesion has been provided in some remarkable electron micrographs by Witte et al. (313). Several scanning electron microscope pictures showing regular holes, estimated by the authors to average 40 to 80 nm in diameter, were presented (Fig. 9). In these photographs, the striking features of these holes are their small size, their number (only one per cell), and their location (either at the midpoint or at the pole of the cell). A thin-section electron micrograph which shows a hole through the envelope, apparently bounded by a fusion of the inner and outer membranes, was also presented. Accordingly, these lesions are called transmembrane tunnels. These are dramatic and compelling pictures which tantalize with the prospect that *E* does something rather clever, i.e., forms a single small hole at a specific and distinct location in the cell. As Witte et al. (313) point out, the finding that there is only one tunnel, or *E*-hole, per cell is actually not surprising, since the formation of such a lesion would collapse the membrane potential and the osmotic gradient across the envelope.

If these lesions are reproducibly characteristic of *E* function, numerous questions arise about how this small protein finds the right spot and then manages to cause the tunnel to form across the entire envelope. As attractive as these pictures are, however, the lack of statistical data about the frequency, size, and locations of these tunnels is cause for caution. Moreover, it is important to remember that these findings appear to be in direct conflict not only with the

observations from light microscopy cited above (157, 258; Fig. 2C) but also with the electron-micrographic evidence presented by Bradley et al. (49, 50) (see above). The picture emerging from both these studies was that, initially, small lesions (about the size of the tunnels) were formed at septal sites, as judged by the emergence of small blebs, and that these blebs eventually grew into spherical cells, bounded by the double membrane. Spherical cells are also formed during MgSO_4 inhibition of *E*-mediated lysis (119). Possibly the conflict reflects the differences between phage-mediated and *E*-mediated lysis, which could be due to ancillary effects of other phage genes or perhaps even to direct effects of the phage particle on the host envelope. In support of the latter possibility, Lubitz and Plapp have documented changes in the protein and murein composition of the host envelope caused by adsorption of ϕX174 virions (194, 195). Noting that plasmid-borne, p_L -mediated expression of *E* supports lysis onset earlier than occurs in the phage-infected cell (43), one might also suspect that the hyperexpression of *E* in the induced plasmid clones leads to an abortive event not characteristic of the normal phage lysis process. That is, Witte et al. (313) may have observed only the small septal tunnels because of *E* expression at a level in such excess that it does not permit the normal morphological changes leading to emergence of the cell sac. In support of this interpretation, Bradley et al. (50) concluded that the smaller septal lesions were characteristic of a small proportion of premature lysis events in the infected culture. Another possibility is that the apparent transmembrane tunnels are the residual structures from destruction, during the fixation process, of the emerging cytoplasmic blebs noted by Bradley et al. (50). In fact, some of the pictures provided by Witte et al. (313) have features suggestive of blebs emerging from the putative tunnels (Fig. 9). It would be especially illuminating to see if whether, with the same conditions for sample preparation and fixation, such tunnels are found in phage-infected cells, whether they have the same size and location, whether this depends on the state of the *shyD* gene, and whether the *E* ΦlacZ fusion genes support the formation of the same kind of lesion. It should be stressed that this interpretation does not minimize the significance of the tunnels, which at the very least provide a macroscopic marker for the subcellular localization of *E* function and provide a structural target for biochemical and immunocytological analysis.

Phage λ with ϕX174 Lysis

The genetic analysis of the ϕX174 lysis pathway is complicated by the fact that the natural host for ϕX174 is *E. coli* C, for which much less sophisticated genetic techniques are available. To overcome this limitation, we have constructed a hybrid λ phage with a deletion of the *SR* genes and carrying the ϕX174 *E* gene under *lacP* control. This hybrid phage is able to make small plaques on wild-type K-12 lawns, as long as *lac* inducer is present, but does not plate at all on a *shyD* lawn (258). Thus a large, complex phage is able to use the single-gene, lysozyme-independent lysis pathway used by the simpler phage ϕX174 . At the end of this review, I shall return to this finding, which raises the question of why the more complex lysis systems have evolved at all. Interestingly, a λ *Sam7 R*⁺ phage carrying the same *E* construction makes larger plaques than the $\Delta(\text{SR})$ version. The notion that the λ endolysin can play a role in *E*-mediated lysis suggests that at least some of the *E*-holes allow escape of proteins from the cytoplasm to the periplasm, rather than exclusively

to the medium as suggested by the tunnel model of Witte et al. (313).

Perspective

Within the rather intimate group of lysis enthusiasts, there is obviously some controversy about the current state of the *E* problem. Nevertheless, it would be a dereliction of duty if this section were not concluded with a working model for ϕ X174 lysis. I suggest that the *slyD* gene product acts or controls a protein target for *E* and that recognition of this target by *E* leads to proper localization to a site at the poles and the incipient septum. Localization of *E* promoters to the septal sites coupled with continued cell elongation and/or cell division leads to formation of a septal lesion in the cell wall. The mechanism by which this disruption is effected may involve limited activation of autolysins or it may be accomplished, without inducing autolytic degradation, by inducing a change in the cross-linking patterns such that the mechanical rigidity of the wall is reduced. A result of this is that a bleb begins to grow out from the septal site, a process which continues until the cell is converted into a sphere bounded by a double membrane and the residual cell wall. In media of normal osmotic strength, bursting will occur at the spherical-cell stage or before, liberating the progeny virions. According to this view, the transmembrane tunnels of Witte et al. (313) would be the characteristic of high-level expression of the *E* gene or *E* action in the absence of other phage genes. There are obviously a number of experiments to be done before any aspect of this model can be taken too seriously, but at the end there is clearly going to be, as Hutchison and Sinsheimer anticipated, a novel mode of phage liberation (156).

RNA PHAGE LYSIS GENES

It has been at least a decade since the existence and regulation of lysis genes in RNA phage were the focus of a burst of papers appearing in very fashionable venues (14, 24, 180, 215, 309). This moment in the public eye, although certainly endowing RNA phage lysis with an elite status in the genre, has unfortunately not attracted much experimental attention. Recently, however, one laboratory has been able to implement an *in vitro* system for modeling the action of the lysis protein *L* of phage MS2, a development which has eluded workers laboring with other lysis systems. The *L* system is lysozyme independent, but it is unclear whether it represents a variation on the theme of the ϕ X174 *E* gene or something utterly different. This review will focus on work on the *L* system, beginning with descriptions of RNA phage physiology that date from the early 1960s. The reader is also alerted to a relatively recent review of single-stranded RNA phage biology, including lysis genes, written by van Duin (294), whose group, along with that of J.-V. Holtje, has led in the investigation of the *L* lysis mechanism and developed the *in vitro* system mentioned above. It should be noted that RNA phages are divided into four groups on the basis of genome size and genetic structure, and lysis genes have been positively identified for the group I phage MS2/*f*2 and the group III phage Q β . Nearly all of the work on RNA phage lysis, and the bulk of this section of the review, is concerned with the MS2/*f*2 lysis phenomenon. Although only a short description of the Q β lysis system is appended here, the reader is asked to keep in mind that the lysis system of Q β appears to be completely different from that of its group I cousins, an evolutionary conundrum if there ever was one.

Lysis Physiology of RNA Phage

Originally, it was reported that, as with the male-specific DNA phage whose particles are extruded from viable cells, lysis is not required for release of *f*2 phage (146). Engelberg and Soudry (89) reported that, in liquid culture, efficient phage release (more than 10^3 virions per cell) occurs concomitant with lysis at 37°C but that a somewhat less efficient release is observed at 30°C despite a continuous increase in optical density. Hoffmann-Berling and Maz  (146) observed nonlytic release of *f*2. However, the "average burst" of only about 10^2 liberated virions per cell could equally well be accounted for by lysis occurring in only a small fraction of the cells, undetectable by turbidity measurements. Lerner and Zinder (188) settled the matter by diluting infected cultures and monitoring bursts from individual infected cells. These data demonstrated unequivocally that, at 30°C, *f*2 phage are liberated from single infected cells in discontinuously single bursts of approximately 2,000 particles, from 75 to approximately 100 min after infection.

Like ϕ X174, MS2/*f*2 seems to require active cell growth to accomplish lysis, since lysis is reported to be inhibited by energy poisons and protein synthesis inhibitors (89, 95, 215). Addition of rifampin at levels sufficient to suppress host transcription can abolish phage release, if done early in infection (89). However, unlike ϕ X174, addition of either rifampin or chloramphenicol to a culture that is already lysing does not immediately halt phage release in MS2/*f*2 infections, as it does in ϕ X174 infections (89). Instead, phage release continues for about 20 min at 37°C. The inhibition of lysis by rifampin treatment of *f*2-infected cells may be related to the inefficient lysis observed at 30°C, since intracellular phage production is unaffected under both conditions.

RNA phage lysis shares the property observed in inductions of the ϕ X174 *E* lysis gene in that empty cell ghosts are the primary product, rather than the total cellular disruption associated with the lysozyme-producing phage (300). In addition, spermine at 1 mM or higher completely prevents *f*2 lysis, as it does ϕ X174 lysis (117). In fact, a lysing culture can be immediately restored to logarithmic growth by addition of 20 mM spermine (117). Inspection of growth curves from *f*2/MS2-infected cells reveals a relatively broad lysis profile (325). It is unclear whether there is any real lag between the accumulation of a sufficient level of a lysis protein and some lysis-triggering event, or whether lysis occurs over a long period in a population of cells.

Lysis Gene *L* of Group I RNA Phage

The group I RNA phages were known to have three prominent reading frames occupying more than 90% of the 3.6-kb genome and encoding the maturation (*A*) protein, coat protein, and RNA replicase (Fig. 11) (294). Model et al. (215) isolated an *f*2 mutant, designated op3, which failed to lyse host cells, although it complemented nonsense mutants with mutations in all three known genes. Atkins et al. (14) and Beremand and Blumenthal (24) demonstrated that the op3 mutation defined a fourth gene, *L*, required for lysis and embedded out of frame in both the coat protein and replicase genes (Fig. 11). The *L* protein was identified as a membrane-bound polypeptide (24). Coat protein has also been implicated in the lysis phenomenon, since coat amber mutants with unaltered *L* genes fail to lyse nonsuppressing hosts. Moreover, these amber mutants, introduced into an appropriate suppressor host, still fail to cause lysis even though

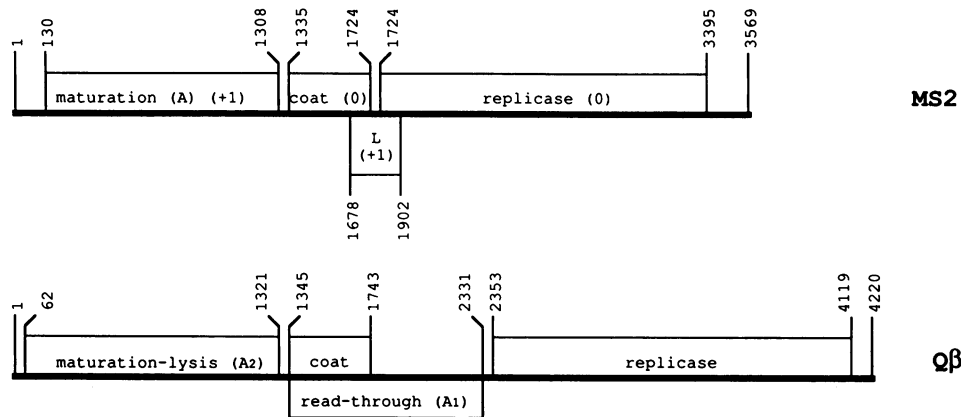

FIG. 11. Maps of the single-stranded RNA phages MS2 and Q β . Numbers are nucleotides from the 5' end of the viral strand. The starting and ending positions of each gene are indicated. For MS2, the reading frames of the four genes are given in parentheses.

functional particles are produced (325). However, expression of L cloned in multicopy plasmids under the transcriptional control of tandem *lpp-lac* promoters or from the λp_L promoter results in lysis (68, 265), which shows that, at least when expressed at sufficient level, L can mediate lysis in the absence of any other phage gene. The nonlytic phenotype of the unsuppressed coat amber mutants can be explained in terms of a requirement for the translation of the coat gene in order to get expression of L (see below). The phenotype of the suppressed coat amber mutants has not been explained, but it is likely that the failure to obtain lysis reflects the relatively low efficiency of nonsense suppression leading to reduced expression of L (293). Since coat protein has a regulatory function as a translational repressor for replicase and is known to compete for RNA-binding sites with replicase, it would not be surprising to find that the nonlytic phenotype of the suppressed coat mutants was an indirect effect on the expression of L. However, until L production is assessed directly in infections of the suppressed coat amber mutants, it cannot be ruled out that coat protein has an auxiliary effect in MS2 phage lysis (i.e., lysis may be more rapid or require less L accumulation in the presence of coat protein).

Regulation of L Synthesis

Almost every aspect of the regulation of L expression is controversial, including the question of how much L is made during infection. The level of L expression *in vivo* can be deduced from the data of Beremand and Blumenthal (24), who analyzed the kinetics of labeling of all four f2 proteins during the infective cycle. Figure 8 of their paper shows clearly that, assuming that the presence of rifampin (used to suppress background gene expression) does not significantly distort the relative synthesis of coat protein and L, the amount of labeled leucine incorporated into L is about 5 to 10% of that incorporated into coat protein. Assuming that there is a minimum of 5×10^3 progeny particles (216) and that all the coat protein is assembled into particles at 180 copies per virion (305), we can estimate that at least 10^6 coat molecules per cell are produced, which would imply about 10^5 L molecules, even after correcting for the different numbers of leucine residues in L and coat protein. This level is probably more than two orders of magnitude higher than that observed for the ϕ X174 E and λ S proteins and is particularly striking in view of the relatively gradual lysis

profile found for group I RNA phage infections and even for the efficiently expressed clones of L (180). Unaccountably, there have been assertions, referring to the same densitometry data, that L is made in very small quantities (66, 68, 180). Although this may reflect differences in what "small quantities" means, van Duin has reported that synthesis at this level (i.e., 10% of the level of coat production) should have rendered L detectable by nonimmunological means but did not. He concluded that the absolute production levels of L are significantly lower than the Beremand and Blumenthal data would indicate (293).

Beremand and Blumenthal also note that L synthesis follows a unique temporal pattern, detectably labeled only after about a 20-min lag (24), a pattern which contrasts with that of coat and A protein, which are produced throughout infection, and replicase, which is made early but is then shut off at about the same time that L begins to be synthesized (see Fig. 8 of reference 24). Remembering that the coat-mediated repression of replicase is used as a paradigm of translational control in introductory textbooks, it is somewhat puzzling that the reported delayed onset of L expression has received no experimental attention. Several papers have appeared on the subject of translational control of L without referring to its temporal regulation. Kastelein et al. reported the lysis phenotypes associated with plasmid constructs in which various segments of the MS2 genome had been cloned under the inducible transcriptional control of the λp_L promoter (180). In all constructs in which the coat and L protein sequences were intact, thermal induction led to lysis, and inactivation of the L sequence by deletion abolished lysis, thus far consistent with the lysis phenotypes established in infections. However, manipulation of an *EcoRI* site spanning codons 95 to 97 of the coat gene had dramatic effects on the induced lysis, which are ascribed to the existence of two out-of-frame UAA stop codons (Fig. 12). These stops are in the -1 and +1 frames relative to the coat gene, and they are separated from the position of the L start codon by 23 and 3 nt, respectively. Constructs in which the coat reading frame is altered by insertion or deletion to give translational stops at either of these UAA codons resulted in rapid lysis. Moreover, a stop inserted at codon 97, which would be 47 nt from the L start, does not permit lysis. The lytic capacity of the frameshifts indicated that termination of coat translation sufficiently near the start of L led to efficient L translation. By extension, then, the depen-

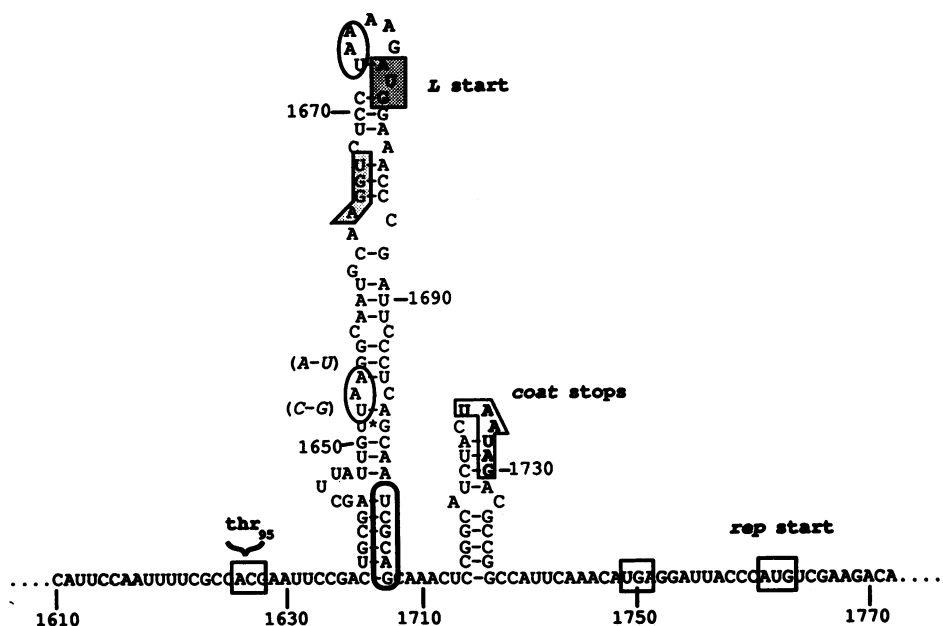

FIG. 12. Model for the translational start region of the MS2 *L* gene. Numbering is as in Fig. 11. The lysine hairpin of van Duin (294) is shown, with the Shine-Dalgarno and AUG start codons for *L* in shaded boxes and the tandem stop codons for the coat gene in the irregular, unshaded box. Another unshaded box at nt 1750 indicates an in-frame downstream stop for *coat*, the use of which fails to permit *L* translation. Out-of-frame stop codons originally thought to be involved in *L* regulation are outlined with ovals. Codon 95 (Thr) of the *coat* gene, deletion of which abolishes lysis competence, is boxed. The 6 bases (nt 1702 to 1707) thought to be critical for stabilization of the lysine hairpin are surrounded by the elongated, unshaded oval. The start codon for the distal *rep* gene is boxed at nt 1751 to 1753. Two single-base changes preserving the hairpin, found in the closely related phage M12, are shown in italics.

dence of lysis on coat expression noted above was ascribed to the necessity for occasional ribosomal frameshifting during passage through the wild-type coat cistron. These frameshifts would occur in the region 5' of the two out-of-frame stops and would lead to initiation, presumably of the shifted ribosome, at the nearby *L* start. However, in-frame deletions of the coat gene around the *EcoRI* site do not support induced lysis, including a simple deletion of codon 95 (Fig. 12). This was rationalized as indicating that the RNA sequence in this region constitutes a "shifty" sequence, so that small changes may abolish or greatly reduce the spontaneous frameshift frequency during the translation of the coat gene. This occasional-frameshift model also rationalized the surprising nonlytic phenotype associated with f2 infections of *rpsL* hosts (67), since streptomycin-resistant ribosomes have been shown to have a decreased frequency of frameshift errors (114). Unfortunately, no direct assessment of the level of *L* protein was provided independent of the lysis profile, nor was the stability of the induced mRNA determined, so less attractive explanations involving the role of secondary structure and translatability and/or RNA degradation are also possible. In addition, the data are equally compatible with the notion that coat protein assists in *L*-mediated lysis. In this case, one could argue that the constructed frameshifts lead to an abnormally high level of *L* synthesis in which coat protein assistance is superfluous. More recently, results from the same laboratory have shown that the frameshift mechanism is not the determinant of *L* regulation (28). Removal of the two out-of-frame stops by using site-directed mutagenesis without altering the coat protein sequence had no effect on the induced lysis. A new model was proposed in which the event required for *L* expression is the termination event at the normal stop codon

of the coat gene. The idea is that the ribosome stalls at the UAA stop codon at the end of the coat reading frame and awaits release by termination factor. The presence of the ribosome at this position causes destabilization of a secondary structure which blocks access to the ribosome-binding site for *L* (28, 265). This model is based on the observation that elimination of the two tandem stops (UAA-UAG) at the end of the coat gene abolishes induced lysis, presumably because a more distal termination event at a UGA eight codons downstream does not destabilize the repressive secondary structure (Fig. 12). This region does seem to be in a complex secondary structure as judged by chemical and enzyme sensitivities of *in vitro* transcripts corresponding to segments of the MS2 genome surrounding the *L* gene (265). *In vitro* translation of f2 RNA supports this conclusion. Using an S30 preparation, Cody and Conway showed that formaldehyde-treated f2 RNA supported the synthesis of about equal amounts of coat and *L* protein, whereas native f2 RNA was translated only into coat and a small amount of replicase (66). Another aspect of the story was revealed when Adhin and van Duin reported that placing a new start codon between the coat stop and the *L* initiation codon blocks *L* expression (7). This indicates that it is the ribosome just terminating translation of the coat protein that has the opportunity to translate *L*. The idea is that the terminated ribosome scans linearly along the RNA to find the *L* start; presumably, the secondary structure acts as a translational repressor by impeding such scanning.

This is an attractive and detailed explanation for the ability of MS2 to maintain a certain stoichiometric ratio in the production of coat and lysis protein. One criticism of the new model is that it does not explain the lysis-negative phenotypes of the in-frame coat gene deletions, especially

the codon 95 deletion. However, labeling experiments have shown that coat synthesis is substantially reduced with these in-frame deletions (60% reduced with the codon 95 deletion allele), which presumably reflects a reduction in the overall mRNA stability (25). By engineering the *L* constructs to increase the translation rate of the coat cistron, these in-frame deletions can be restored to lytic proficiency (25). Another point for caution is that the structure of the unbound RNA is unlikely to resemble the structure of the MS2 RNA *in vivo* when, at least, the coat cistron is being translated at a high rate. Further, one must be somewhat wary about drawing conclusions about the structure and translation of *L*-containing segments of the MS2 genome when it is known that the intact MS2 genome exists *in vivo* in a dynamic state exquisitely tuned for appropriate balance in the expression of the four gene products. This is especially worrisome in view of the demonstrated sensitivity of *L* expression to very small changes in the upstream RNA sequence (27, 28). One would hope that the model would be tested directly, perhaps by synthesizing *in vitro* transcripts incorporating the appropriate changes and corresponding to large segments or all of the MS2 genome, transfecting these transcripts into *E. coli*, and assessing *L* production by labeling and immunoprecipitation.

An interesting twist on this story comes from Adhin et al., who reported that the *L* gene of the related (but serologically distinct) group I RNA phage, fr, lacked an AUG or GUG in the putative *L* reading frame (5). The authors demonstrate that, instead, a UUG codon serves as the *L* initiation codon. Since differences in the upstream primary sequence suggest that the secondary structure implicated in repression of *L* in MS2 is not likely to be stable in fr, the authors posit that it is the choice of such a poor initiation codon which prevents free access of ribosomes to *L* and keeps it translationally coupled to the coat gene. This idea is supported by the finding that converting the UUG to an AUG or GUG makes *L* expression and lysis independent of coat translation, as judged by induction of various partial fr plasmid clones. Since IF3 has been implicated in proofreading initiation complexes for alignment over noncognate start codons (29, 120), the authors speculate that such proofreading is bypassed by those ribosomes which, instead of dissociating from the mRNA, diffuse in a phaseless walk from the coat stop to the *L* start. In the group I phage GA, the start codon of the *L* gene is an AUG which actually overlaps the stop codon of the coat gene. One would think that this would lead to efficient translational coupling and thus to a higher *L*-to-coat production ratio, but the lack of a consensus Shine-Dalgarno sequence within 12 to 14 nt upstream of the *L* start probably exerts a negative effect on the initiation frequency (294).

L Protein: Structure and Function

The *L* gene has 75 codons and has almost a reverse organization with respect to ϕ X174 *E*, in that *L* encodes a polypeptide with a hydrophilic N terminus (9 basic, 3 acidic, and 15 uncharged polar residues encoded in the first 37 codons) and a lipophilic C-terminal domain (27 hydrophobic and only 3 charged residues specified in the last 38 codons) (Fig. 8B). It is not as easy to postulate specific membrane-spanning domains in *L* as it is in *E* because even in the lipophilic C terminus, there is no stretch of more than 12 residues unbroken by charged amino acids. Berkhout et al. note that Chou-Fasman analysis of the primary sequence predicts three adjacent beta-sheet stretches in this region

(26). As stated above, the validity of applying the Chou-Fasman empiricism, derived from the structure of soluble proteins, to membrane proteins is doubtful. Much of the N-terminal hydrophilic region appears to be nonessential for lytic function, as demonstrated by Berkhout et al. using a series of N-terminal deletions cloned under p_L control (26). As a result of the cloning and deletionogenesis procedure, the products of these deletions each carried slightly different N-terminal sequences (Fig. 8B), and, perhaps in consequence, the modified *L* proteins had widely different stabilities. Nevertheless, for deletions as far as 43 codons into *L*, in every case in which the protein product was stable enough to be detectable by immunoblotting with anti-*L* antibody, the deletion allele was found to be lytically competent when its expression is induced from a plasmid-borne p_L promoter. C-terminal deletions, even missing as few as four residues, were uniformly nonfunctional and, on the basis of the failure to detect the protein in Western blots, unstable. The functionally homologous *L* proteins predicted from the sequences of the other group I phages fr and GA share the same general primary structure features, in terms of patterns of charged, neutral, and hydrophobic residues (Fig. 8B). The only residues conserved in all three are in the more hydrophobic C-terminal half of the protein sequence.

Harkness and Lubitz (127) constructed an *E* Φ *L* fusion gene encoding a hybrid product consisting of the first 54 residues of *E*, a 5-residue linker (containing two glycine and one proline residues), and the last 55 residues of *L*. The fusion gene and the *E* and *L* parental genes were all cloned under control of a λp_L promoter on a pBR322 derivative vector and transformed into a host which expresses the λ cI857 repressor. When expression of the cloned genes was induced by shifting to 42°C, this fusion gene caused lysis onset at about 25 to 30 min, compared with approximately 8 min for *E* and approximately 40 min for *L*. This is hard to interpret with confidence, since the actual synthesis rates of the three lysis proteins were not determined. Moreover, since it has already been shown that lytic function is preserved even if the first two-thirds of *L* are deleted as long as the residual product is stable enough to accumulate (26), the simplest interpretation is that the *E* sequences merely serve to stabilize the otherwise nonfunctional *L* fragment.

A paper by Walderich et al. (300) deals with many aspects of *L* function, including the effects of the physiological environment on *L*-induced lysis, the ultrastructure of the sacculus after lysis, and the subcellular localization of the *L* protein. Addressing the latter, the authors performed isopycnic sucrose gradient analysis on the membrane material from French-pressed cell lysates and, surprisingly, found that about half of the total cellular membrane protein is found in neither the heavy (i.e., the outer membrane) fractions nor the light (i.e., inner membrane) fractions but instead in fractions of intermediate density. The impression given is that *L* is actually causing the accumulation of the intermediate-density material. To reinforce this notion, the authors have determined the frequency of membrane adhesion sites by using thin-section electron micrographs of cells in which *L* has been expressed. They find an *L*-dependent increase of 17% in the calculated frequency of adhesion zones, from about 430 to 500 per cell, based on the examination of more than 1,200 cells! Unfortunately, the method used in performing this Herculean task was not described, nor were examples provided of what was counted as an adhesion zone in the micrographs.

Höltje and van Duin examined a number of physiological and biochemical parameters during lysis induced by expres-

sion of *L* cloned under λp_L control (149). No change in murein biosynthesis, membrane permeability, active transport, or cell shape could be detected preceding the actual onset of lysis. Interestingly, however, these authors found that lysis is either absent or delayed and very gradual in cultures grown and induced at pH 5. This result has been confirmed by Walderich et al. and shown not to be attributable to defects in *L* protein synthesis or gross membrane localization (300). Since normally lytic β -lactam antibiotics have been shown to be lysis incompetent for *E. coli* grown and treated at low pH (113), this parallel with β -lactam function led Walderich et al. (300) to suggest that the *L* and penicillin lysis pathways may share a pH-sensitive step, presumably involving the cellular autolysis system. In addition, high-pressure liquid chromatography analysis of murein fragments generated by amylase and pronase digestion and borohydride reduction revealed that *L*-mediated lysis was accompanied by a slight reduction in the average length of glycan strands and a change in cross-linking patterns (300). In the absence of nonlytic controls for the same growth conditions, however, it is not clear how much of this change can be correlated with lysis and how much with the induction conditions (i.e., thermal shift). Direct visual inspection of sacculi purified in hot SDS revealed no significant alteration, suggesting that if murein degradation is required for *L*-mediated lysis, it must be localized and strictly limited. A further correlation with the action of penicillin is suggested by the authors' observation that *L*-mediated lysis is slightly retarded in cells in which the stringent response has been superimposed on *L* induction by addition of *L*-valine to a level sufficient to inhibit isoleucine biosynthesis. The stringent response induces a gradual change in the murein, making it increasingly insensitive to the penicillin-induced autolysis (148).

How does *L* work? In view of the relatively large number of *L* molecules produced in a lytic infection, it seems entirely possible that *L*-mediated lysis is an entirely distinct mechanism from that of *E* or *S*. Supporting this notion, it was reported that induction of a cloned *L* gene failed to cause lysis of cells deficient in the production of membrane-derived oligosaccharides (MDO), whereas an *E* gene clone was lytic under the same conditions (147). This was ascribed to a failure of *L* protein to localize to the membrane fraction, as judged by Western blot. Inspection of the data, however, indicates this MDO-dependent failure to localize to the membrane occurs only when *L* is expressed from a plasmid carrying the coat and *L* genes (see Fig. 2B of reference 147). When a plasmid carrying only the *L* gene was used, the membrane samples clearly contained a reactive protein of the same M_r (see Fig. 2A of reference 147), although it was this plasmid that failed to cause lysis in the MDO⁻ host. In any case, if this effect is a direct consequence of the alteration of the periplasmic gel, the mode by which *L* becomes bound to the cell envelope must be exceedingly complex. To account for these findings, Walderich et al. (300) argue that stable binding of *L* to the envelope requires the formation of complex structures (adhesion zones?) involving the inner and outer membranes and the contents of the periplasm. In a technical triumph, Walderich and Hölftje (299) have provided direct evidence for such structures. Using protein A-gold deposition and antibody raised against a synthetic polypeptide corresponding to the last 25 residues of *L* (L25; Fig. 8B), these authors examined the distribution of *L* antigen in thin sections of cells induced for the expression of a plasmid-borne *L* gene. About 70% of the gold grains were positively located over membrane structures, and,

within this population, the distribution of the gold grains was enriched 8- to 10-fold over structures identified as adhesion sites. This enrichment was about twofold less in thin sections prepared from cells grown at pH 5. The enrichment on the adhesion sites may be understated somewhat, since about 30% of the grains were found over the periplasmic space. Since *L* is known to be membrane bound, these grains may actually represent *L* bound to adhesion sites which were not visible under the low-contrast conditions used. In the method used, the cells were harvested at the time of lysis onset and plasmolyzed in 60% sucrose for 10 min before fixation. In the photomicrographs presented, the clustering of gold grains over long, distended adhesion sites in the plasmolyzed cells is quite dramatic and convincing (Fig. 13). One would suppose that plasmolysis can be observed only in cells not yet permeabilized by *L*, and indeed in one photomicrograph (panel a of Fig. 2 in reference 299) a cell without an enlarged periplasm is visible, presumably one in which an *L*-hole(s) has destroyed the sucrose impermeability of the membrane. Although, on this basis, one cannot discern whether *L* is accumulating in adhesion zones or, as suggested previously (300), actually causing the formation of adhesion sites, it is interesting that this process is inhibited only twofold under the pH 5 growth conditions. The authors suggest that localization of *L* in adhesion zones occurs before, and may be required for, activation of the cellular autolysis system. This work is quite impressive and unprecedented for membrane-bound lysis proteins. Similar efforts to localize *S* and *E* in thin sections have been made in my laboratory and in others. These efforts have been uniformly unsuccessful even in detecting the antigen at all, much less localizing them to subcellular structures. This may point up the large differences in the stoichiometries of *L* (10^5 molecules per cell) and *S* or *E* (10^2 to 10^3 molecules per cell). In any case, it seems likely that the possibility that *L* binds some adhesion site-specific structure would be amenable to genetic analysis, in the sense that it should be possible to isolate host mutants which survive *L* expression. Interestingly, it was not reported whether the MDO⁻ mutants were resistant to *L*-mediated killing in the conditions under which no lysis was observed (147). The alternative, that *L* forms adhesion sites of its own accord, without interacting with host protein, would be favored if such a mutant hunt were unsuccessful. In this case, it seems likely that one could obtain *L* mutants which could still localize in the membrane but fail in adhesion zone formation.

In Vitro Lysis System for *L*

As mentioned above, *L* has the distinction of being the only lysis protein for which an in vitro system has been established. Actually, the in vitro system has been used on the synthetic L25 peptide mentioned above, which seems reasonable in view of the data suggesting that the N-terminal domain may be dispensable for *L* function (26). Goessens et al. (110), in a tour de force that included almost every conceivable system involving membrane vesicles, showed that the L25 peptide was capable of dissipating an established electrochemical potential. The L25 peptide has the following sequence:

+0***000*00-000+*0**0**00*-
FTNQLLLSLLEAVIRTVTTLQQLLT

(where 0, *, +, and - represent hydrophobic, polar, positively charged, and negatively charged residues, respectively). This molecule is water insoluble and is added to the

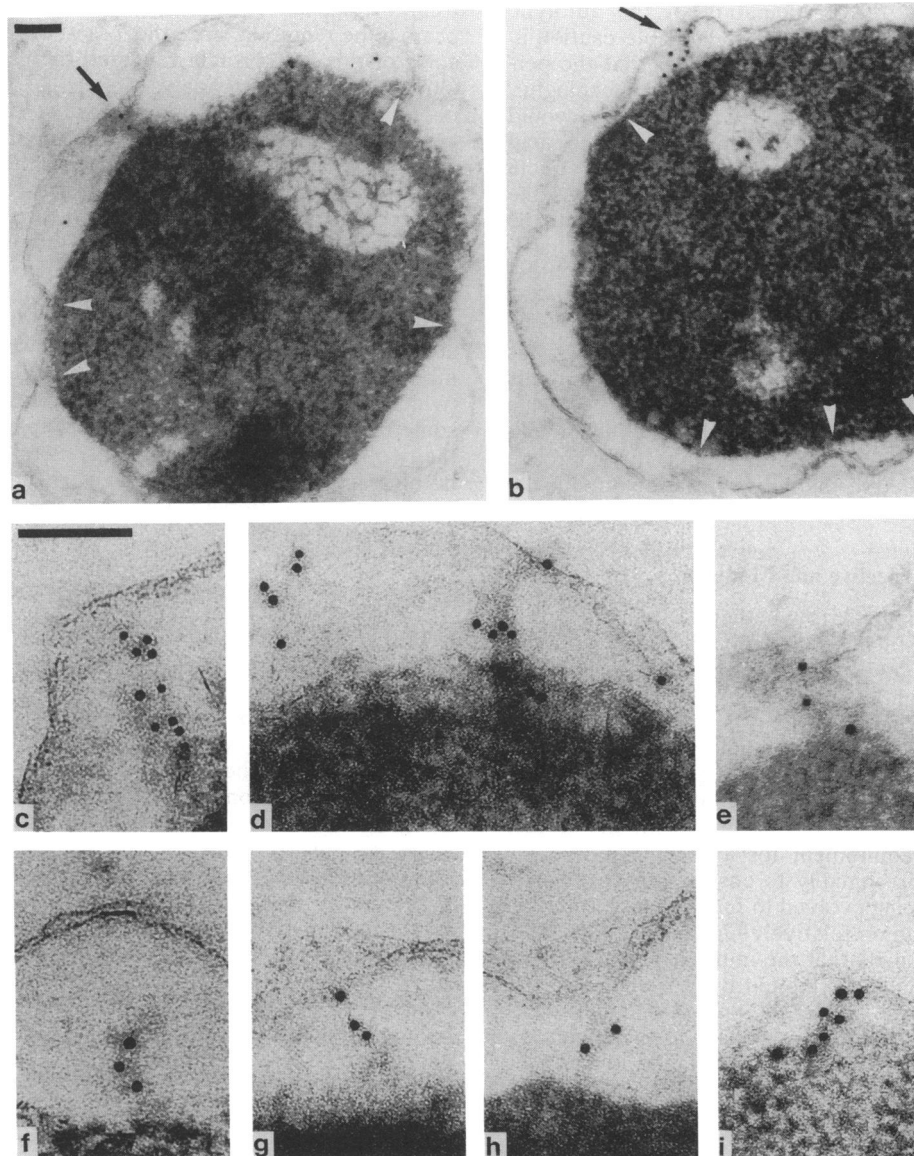

FIG. 13. Localization of L protein to membrane adhesion sites. Cells lysed by induction of a cloned L gene were analyzed by immunoelectron microscopy. Thin sections are stained with protein A-gold after reacting with anti-L-protein antiserum. See reference 299 for experimental details. Arrowheads and arrows indicated unlabeled and labeled adhesion zones, respectively. Reprinted from reference 299 with permission.

various vesicle preparations as a dimethylformamide solution. In a series of experiments yielding extremely clear-cut results, the L25 peptide was shown to have the following properties: (i) it collapsed the pH gradient formed by addition of D-lactate and valinomycin to everted *E. coli* membrane vesicles; (ii) it abolished proline uptake in energized "right-side-out" vesicles (175); (iii) it dissipated the electrical potential formed by adding ascorbate to unilamellar liposomes reconstituted with cytochrome *c*; and (iv) it caused the preferential release of carboxyfluorescein (>80% released) over inulin (<20% released) from unilamellar liposomes. All of these properties were demonstrated at lipid-to-peptide ratios of about 100:1, which indicates that the peptide is not acting as a detergentlike molecule but rather is actually forming a pore of some sort. These data seem to

dovetail nicely with the previous findings from this laboratory showing that the C-terminal fragments of L, if sufficiently stable to accumulate to levels approximating those of the wild-type protein, can cause lysis (see above). One can certainly conclude that the L25 polypeptide seems to be able to bind to and permeabilize membranes irrespective of the lipid constitution or protein content. It is a little puzzling, as the authors point out, that the L-holes seem to release carboxyfluorescein more efficiently than inulin, although some inulin is certainly released. Does this mean that the effective diameter of L-holes is not discrete but varies according to some distribution? Clearly, holes so small could not directly cause release of MS2 virions, so the authors suggest that hole formation triggers the autolytic system, which then leads to lysis and phage liberation. There is still

no direct evidence of the participation of the autolytic system, however. The authors exercise laudable caution in interpreting these findings, since it is unclear that the permeabilization effects observed are biologically meaningful, in the absence of a negative control. In other words, would any polypeptide of approximately the same amino acid composition have the same effects on these various vesicle species? It would be especially convincing if the same experiments performed with an L25 species altered to be analogous to the product of a lysis-defective C-terminal *L* missense mutant could be shown to be defective in these properties. Unfortunately, lysis-defective missense alleles of *L* have not been described. Nevertheless, this impressive work points the way to similar analyses with other lysis proteins such as S and E, for which a multitude of mutants have been characterized. Also, given the powerful new gene fusion methods that might be used for production of full-length L protein (227, 266) one can hope that this approach will ultimately be applied to the native protein with equally intriguing results.

Perspective and Model

At the end, we come back to whether L lysis is different from E lysis. There is still little to go on, other than sequence gazing, where to these eyes there is near total dissimilarity. The necessity for high-level synthesis and the relatively gradual lysis profiles characteristic of *L* suggest that it may function in a manner more akin to small lytic peptides such as defensins (98), alamethicin (123), and enterococcal microcins (97). A satisfying synthesis can be made, if one regards E and L as similar lytic agents with the former having evolved the requirement for a specific interaction with a host protein, presumably to ensure proper localization, and the latter having evolved to function more nonspecifically, relying instead on relatively high levels of accumulation. This model predicts that the initial L lesion may not show the septal specificity exhibited by E and that L will function in *styD* hosts. In fact, it predicts that no host mutations which are specifically resistant to the accumulation of L will be found, unless the resistance is mediated indirectly through changes in membrane lipid composition or the like.

Group III RNA Phage

Bacteriophage Q β , as the prototype group III RNA phage, has a genome almost 20% larger than that of the MS2/f2 (group I) phage but has only three reading frames, corresponding to the genes for the maturation protein, coat protein, and replicase (294) (Fig. 11). That is, instead of the *L* gene overlapping the end of the coat gene and the beginning of the replicase genes, as in MS2, stop codons are found in all three reading frames in this region. Two groups showed that expression of cDNA clones of the complete or partial Q β genome reproduced the lysis observed with Q β infection (179, 309). Deletion analysis led both groups to the surprising conclusion that lytic function was localized to the maturation gene, designated as *A*₂ in group III phage (Fig. 11) and encoding a 46K product. There are a number of small +1 reading frames within *A*₂ which might encode lysis proteins, especially the reading frame beginning at nt 566, which could give rise to a highly hydrophobic polypeptide of 54 residues. However, frameshifts introduced by altering unique restriction sites in *A*₂ abolish lysis in the cDNA clone inductions, irrespective of whether the small +1 reading

frames are unaffected (179). The complete *A*₂ protein appears to be required, since the loss of only the last 24 amino acids of this 46K protein rendered the gene lysis defective (309). Hydropathicity analysis of the *A*₂ protein reveals no potential membrane-spanning domains. Thus Q β *A*₂ protein appears to have a dual function, involved both in the maturation of virions and in host lysis. Little is known about the mechanism of *A*₂-dependent lysis. There was an early report that cell wall synthesis, as measured by diaminopimelate incorporation, is reduced beginning about midway through the Q β infective cycle (232). In addition, the lysis and maturation functions are separable *in vivo*. If host protein synthesis is prevented by the addition of rifampin at about 5 min after infection, lysis is abolished without reducing the intracellular accumulation of viable phage particles (which include one copy of the *A*₂ protein each) (179). For some reason, since the simultaneous appearance in 1983 of the two reports documenting the lysis role of *A*₂ (179, 309), nothing has appeared since. This is unfortunate, since it appears to be a simple system and may define an entirely new mechanism of lysis.

BACTERIOPHAGE T7

T7, like λ , is a complex phage for which the entire genomic sequence (39,936 bp) has been determined (85). For anyone who has ever done an infection with T7 (or T3, its close relative), it is obvious that this is a viciously lytic phage—abrupt and massive lysis occurs about 25 min after infection at 30°C. (Unless otherwise stated, the infection times cited here refer to infections at 30°C, precisely because at 37°C the T7 phage lytic cycle is too compressed for convenient analysis.) It was noted above that the existence of prominent murein hydrolase activities elaborated in lambdoid and T-even infections actually distracted attention from the mechanism of phage lysis. This should not have inhibited interest in T7 lysis, since the only detectable lysozyme activity was found, early on, to be irrelevant to the lysis process (271). Despite this surprising and unprecedented finding, only one effort has been reported in which lysis mutants were explicitly sought (214). Thus, even though T7 phage has survived and even thrived in the eukaryotic era as a consequence of its marvelously powerful systems for macromolecular synthesis, the T7 lysis phenomenon has languished unattended for years. A reconsideration of the literature, coupled with recent preliminary results from the laboratory of F. W. Studier, suggests that this obscurity is unjustified. In fact, T7 lysis seems to share features with both general types of lysis systems reviewed so far (i.e., lysozyme-dependent and lysozyme-free lysis).

A Lysozyme Discredited

T7 genes are of three classes, grouped by physical location, function, and time of expression: class I or early genes, occupying the leftmost 19% of the genome and transcribed by the host RNA polymerase until about 8 min after infection; class II genes, occupying the next 27% of the genome, associated with DNA metabolism, and transcribed by T7 RNA polymerase in the 6- to 15-min interval after infection; and class III genes, comprising maturation and morphogenesis genes, occupying the rest of the genome, and transcribed from about 6 min after infection until lysis (132) (Fig. 14). Early in T7 history, it was found that class II expression gives rise to a powerful murein hydrolase activity, which was mapped to gene 3.5, amid a cluster of DNA metabolism

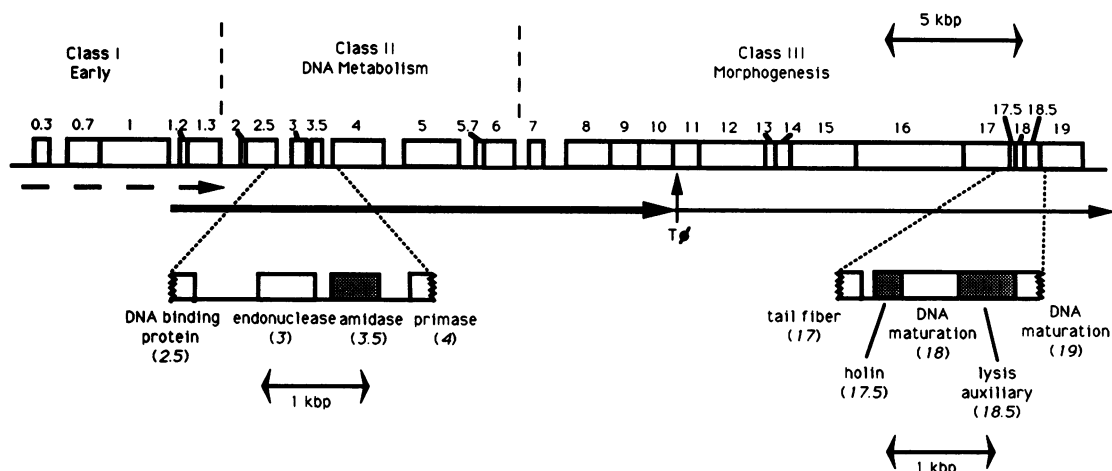

FIG. 14. Location of lysis genes in the T7 genome. The T7 genome is drawn to scale with all known essential genes, divided into transcription classes as indicated. The dashed arrow indicates the major transcript synthesized by the host polymerase. The solid arrows indicate the major transcripts synthesized by the T7 RNA polymerase. The major T7 terminator is indicated by $T\phi$. Blow-ups show the location of the lysis genes 3.5 in the class II region and 17.5 and 18.5 in the class III region.

genes (164, 283). The enzyme has been called lysozyme even though it is an *N*-acetylmuramyl-L-alanine amidase (164). Studier (283) reported that a T7 3.5am mutant totally deficient in lysozyme activity nevertheless causes lysis of a nonpermissive host and makes small plaques. Silberstein et al. (271) found that in infections with 3.5 mutants, it is a defect in phage DNA replication which reduces the phage yield to only 20% of the wild-type yield. A possible role for lysozyme in releasing host and phage DNA from cell wall attachment (260, 271) was suggested, based on experiments in which pulse-labeled host and T7 DNA was found in rapidly sedimenting material in 3.5am infections. The view that T7 lysozyme is not involved in lysis has been widely accepted (131, 189), although it has never been obvious how a murein hydrolase activity could directly affect membrane or envelope structure from the cytoplasm.

Identification of a Lysis Gene

After the discrediting of 3.5 as a lysis gene, Miyazaki et al. (214) used the strategy employed by Josslin to identify T4 *t* (172) to enrich for T3 phage mutations causing hyperaccumulation of virions in nonsuppressing cells. They identified mutations in a locus designed *lys*, which was mapped between the class III morphogenetic genes 17 and 19 (Fig. 14). The *lys* mutations were shown to have no effect on the accumulation of lysozyme activity (214). The turbidity of cells infected with the *lys* mutant was, especially in view of the catastrophic and sudden lysis supported at 15 to 20 min by the wild-type phage, quite distinctive: the infected culture continues to grow for about 90 min, after which turbidity decreases very slowly over the next 2.5 h. Phage particles accumulate to levels much higher than do wild-type phage particles but are only gradually released, beginning at about 60 min. This may seem a much leakier phenotype than one would expect from the equivalent of a λ *S* or ϕ X174 *E* amber mutant, but it should be kept in mind that T7 infection is a much more devastating event in terms of host physiology, as judged by the total dissolution of the host chromosome if nothing else. Presumably, the delayed and gradual release of particles after 1 h of infection reflects an acceleration of nonspecific deterioration of membrane integrity. The rela-

tively high efficiency of plating (about 0.1) on nonsuppressing lawns is thus due to the gradual nonspecific release being partially compensated by the increased phage production per infective center. The T3 *lys* gene appears to be 17.5 in T7 nomenclature, since 17.5am mutants behave identically (314, 321). 17.5 encodes a 67-residue polypeptide, which, although lacking sequence similarity to its functional homologs in lambdoid and T4 phages, has an organization characteristic of the lambdoid holins: two hydrophobic domains of net neutral charge separated by a predicted beta-turn region and an extremely hydrophilic, highly charged C terminus (Fig. 8A). Interestingly, the nearby downstream gene 18.5 has sufficient sequence similarity to the λ *Rz* genes to indicate that these two cistrons share the same function, albeit ill defined, in the lysis pathway (Fig. 14) (61). Unlike λ , however, the *S*-like gene (17.5) and the *Rz*-like gene (18.5) of T7 do not constitute a lysis cassette, since the intervening gene 18 is involved in DNA maturation (Fig. 14). It would be odd if T7 elaborated an *S*-like holin and an *Rz* homolog without also elaborating a murein hydrolase, and, it turns out, this is not the case.

Lysozyme Redux

Recent efforts in the Studier laboratory have led to a reconsideration of the lysis phenomenon and, more specifically, to the rehabilitation of lysozyme as a factor in lysis. First, it was shown that purified T7 lysozyme has, in addition to its amidase activity, a second and apparently unrelated capacity: binding to and inhibiting the T7 RNA polymerase (217). In T7 infections, the normal process is for T7 RNA polymerase activity to be greatly reduced at the onset of DNA replication. 3.5 is responsible for this tuning down of transcription, and presumably the severe diminishment of T7 DNA replication in 3.5 mutants reflects the antagonism between continued high-level transcription and replication (217, 219). A deletion of the first 4 codons of 3.5 abolishes the polymerase-binding capacity of the lysozyme without affecting its ability to degrade the peptidoglycan (284). This mutant thus retains the replication defect. Nevertheless, some phage are still produced and released, enough at least to permit the formation of small plaques with normal effi-

ciency. Significantly, the same number of phage particles are produced when 3.5 is totally deleted, but these particles are mostly trapped in sedimentable debris. We can infer, then, that the T7 lysozyme activity is required for efficient phage release.

Parallels with λ and T4?

These new findings implicating T7 lysozyme in lysis, coupled with the properties of 17.5 mutants, suggest that 17.5 and 3.5 play the same roles as the λ *S/R* and T4 *t/e* gene pairs. In support of this, Hausmann (130, 131) noted that CN^- addition at 6 min or later (at 37°C) triggers premature lysis. Thus, gp17.5 should be a membrane protein which, upon some physiologic trigger that is imitated by the addition of CN^- , forms holes in the inner membrane through which the soluble lysozyme can pass to the periplasm. The fact that 3.5 mutants can still release a small percentage of the progeny phage suggests that the membrane lesion formed when gp17.5 is triggered may resemble, or have the same effect as, the lesion formed by the action of the ϕ X174 *E* gene. Nevertheless, it seems likely that the proposed role for lysozyme in the release of the host and/or phage genome from the membrane is spurious. In the pulse-labeling experiments which showed that newly synthesized DNA was rapidly sedimentable in the 3.5am infections (but not in wild-type infections), azide was used to stop the labeling (271). This would presumably trigger hole formation by gp17.5, which, in the wild-type infection, would lead to massive release of T7 lysozyme to the periplasm. Since exogenous lysozyme is known to cause artifactual release of DNA from DNA-membrane complexes (271), the failure to observe such a release in the 3.5am infections is not surprising. Also, the sedimentable nature of the pulse-labeled T7 DNA may actually reflect trapped virions in the 3.5am infections, rather than membrane-associated DNA. Thus it seems reasonable to postulate that the only role of the T7 "lysozyme," or more properly, amidase, activity is in lysis.

OTHER PHAGE LYSIS SYSTEMS

Very little is known about any phage lysis systems other than the λ , T4, ϕ X174, MS2, and T7 systems and their close relatives. In a few cases, lysis genes have been identified genetically and deserve mention in this review.

Mu

In phage Mu, a single gene, *lys*, has been identified which satisfies the normal criterion for a lysis gene: defects cause a failure in phage liberation concomitant with synthesis of normal virions at normal or increased levels (92). As in the lambdoid phage, the Mu *lys* gene is the first gene in the late transcript. Nothing is known about the mechanism, nor has the protein been identified in labeling experiments. From the perspective of this review, one would expect a complex phage such as Mu to have a holin-lysozyme system similar to the lambdoid or T-even phage systems. When a thermosensitive Mu lysogen is induced and treated with $CHCl_3$ before the normal lysis time, premature lysis is observed, indicating that a murein hydrolase accumulates during the vegetative phase (170). However, we have not observed premature lysis after the addition of an energy poison, so the Mu lysis system does not seem entirely homologous to the lambdoid and T4 systems. Nevertheless, it seems likely that the failure to identify a holin gene is explained by some variation on the

T7 story, that is, that nonsense or *ts* mutations in the other lysis gene, possibly encoding a holin, do not completely abolish lysis and plaque-forming ability.

P1

As Yarmolinsky and Sternberg (317) have documented in their comprehensive review of P1 biology, P1 was saved from oblivion by the discovery of its ability to mediate generalized transduction. That utilitarian aspect, however, may have also repressed interest in P1 per se, at least until recently. This may be especially unfortunate in terms of lysis mechanisms, for P1 seems to have an interesting system. Walker and Walker (301) tested more than 100 P1 amber mutants for lysis profiles in liquid culture and found two complementation groups with lysis defects, gene 17 and gene 2. Gene 17 appears to encode an endolysin, since cells infected with 17 mutants fail to lyse but cease intracellular phage accumulation at the normal time of lysis (301). Some caution must be applied here, however, since attempts to detect a murein hydrolase activity in P1 lysates were unsuccessful. Gene 17 maps adjacent to some morphogenesis genes at about coordinate 21 on the P1 circular map. Nonsense mutations in a second gene, 2, unlinked to 17, cause early lysis, more than 20 min before the normal lysis time of 40 to 50 min at 37°C (301). In this case, the failure to form plaques on the nonpermissive host results from a severe reduction in phage yield as a result of the premature termination of the vegetative cycle.

Evidence for a third lysis gene is indirect. Iida and Arber (161) isolated P1 deletion mutants which make tiny plaques and have a severely delayed and gradual lysis profile. Moreover, $CHCl_3$ addition causes lysis in cells infected with these mutants, which may be identical to minute plaque-forming deletion mutants designated *P1_{min}* by Rae and Stodolsky (246). These observations have led to the notion that a gene called *hyd*, deleted in these mutants, is a functional analog of λ *S* (301, 317). Sequencing of the *hyd* locus has revealed that there are two adjacent genes, *hydA* and *hydB*, with the stop codon of the former overlapping the start codon of the latter (121, 160, 317). In preliminary experiments, it has been found that disruption of *hydA* causes delayed lysis, whereas a knockout of *hydB* causes accelerated lysis (162). Given the similar phenotypes and the genetic mapping data, it is possible that *hydB* is identical to gene 2. Inspection of the predicted primary sequence of *LydA* reveals a near-canonical holin structure: a 109-residue polypeptide which contains, in the first 60 residues, two predicted membrane-spanning helices separated by a region strongly predicted to have beta-turn properties, and a charged, basic C terminus (Fig. 8A). There are some interesting differences, most notably the overall acidic pI for the predicted product. Also, if one adheres strictly to a requirement for 20 consecutive residues for a potential membrane-spanning domain, one of the two putative membrane domains must be drawn with a net charge of -1.

No more information has appeared on this interesting lysis system, but some clues may be gleaned from raking through the existing data. The absence of nonsense mutations in *hydA*, coupled with the tiny-plaque phenotype of the *hyd* deletions, suggests that at least a minimal phage release can occur in the absence of *Lyd* protein. This may reflect nonspecific membrane perturbations leading to the inefficient release of the putative 17 endolysin. It is worth noting that the deletions defining *hyd* also remove gene 2. Since 2am confers an early lysis phenotype on P1 with functional *hyd*

but $\Delta(2\ lyd)$ exhibits only the delayed and probably nonspecific lytic profile, it is reasonable to suggest the following model: LydA functions by forming a hole in the inner membrane to allow the gp17 endolysins access to the periplasm and the murein layer. LydA-hole formation is inhibited by the action of gp2, thus extending the vegetative cycle sufficiently to allow the assembly of an appropriate number of progeny virions. If 2 is a lysis control gene, it would be a third variation on the theme of lysis control by a negative regulator, including the S105/S107 and S68/S71 systems in λ and phage 21 and the *trII* system in T4. Moreover, the three negative regulation systems appear to be fundamentally different, since the lambdoid dual-start system seems to involve "poisoning" of an oligomeric hole-forming complex, the T4 *rII* gene causes lysis inhibition only upon superinfection, and 2 inhibition appears to be essential for a viable vegetative phase in P1 infections. Several approaches could be used to unravel the P1 lysis system. For example, one might find that small-plaque-forming pseudorevertants of 2am mutants would include suppressors which map to *lyd*. In any case, this system fairly cries out for attention.

P2 and Relations

Phage P2 was originally identified by Bertani (30) in the cohort of phages which included P1, with which it cross-reacts serologically. Since then an extensive series of genetic, physiological, and biochemical efforts has made it abundantly clear that P2 is very different from P1, with vaguely lambdoid properties in terms of temperate life-style and genomic arrangement (31). A large number of P2-like phages have been identified, and one, phage 186, has been subjected to nearly as detailed genetic analysis as has P2. P2 has achieved some fame as the passive partner in the life cycle of the satellite phage P4, which uses the genes of coinfecting phage or prophage P2 for most of its vegetative functions (31). The lambdoid connections of P2 prompt one to suspect a λ -like multigene lysis strategy. However, only a single P2 gene, *K*, has been implicated in lysis (190). *K*^{ts} mutants were found by using the screening method of Streisinger et al. (282) (looking for plaques which cannot form halos after exposure to CHCl₃ at the nonpermissive temperature; see the T4 section). At the nonpermissive temperature, cells infected with P2 *K* stop growth at the normal lysis time (25 min at 37°C) but do not lyse, a phenotype exactly like that of λ Ram. Still not available, however, is a published report of murein-degrading activity in P2 lysates, much less a correlation of such activity with the state of the *K* gene. *K* maps between a cluster of head genes and a cluster of tail genes on the longest late transcriptional unit (Fig. 15).

In coinfections of P4 and P2, lysis timing remains the same, suggesting that P4 does not interfere with whatever lysis regulation is provided by its helper. However, when P4 infects P2 lysogens, and thus depends on transactivation of the heterologous prophage for vegetative functions, lysis is much delayed (264, 275). Since excision of the P2 prophage is extremely inefficient in P4 infections, the lysis delay probably reflects the lower gene dosage of the P2 lysis genes during the latent period rather than distinct P4 lysis regulation.

Phage 186 has a longer latent period, with lysis beginning about 37 min after infection in complete medium (150). Nonsense mutations identified four genes, *A*, *B*, *O*, and *P*, which not only are essential for plaque formation but also showed a lysis defect in liquid-culture infections (145). The

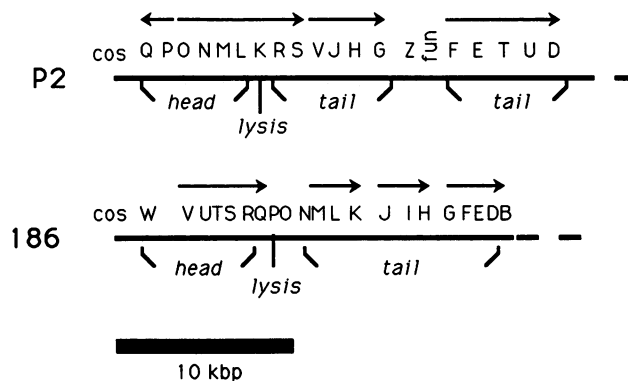

FIG. 15. Location of lysis genes in the P2 and 186 late-gene regions. The direction of transcription, where known, is indicated above the maps.

lysis defects of *A* and *B* are indirect, since these genes are required for DNA replication and late gene expression, respectively. Only one 186 gene (*P*) is listed as a lysis gene in the review by Bertani and Six (31). The map position of *P* is analogous to that of P2 *K* (Fig. 15). Infection of 186 Pam causes cessation of culture growth at the normal lysis time, like P2 *K* and λ R (145). However, there is no report of an attempt to identify murein hydrolase activities in 186-infected cultures. Interestingly, a nonsense mutation in gene *O*, which maps adjacent to *P*, also causes a lysis defect, exhibiting no decrease in the turbidity of the infected cell until about 2 h after infection (145). This lysis phenotype and the juxtaposition with the *P* lysis gene suggests that *O* might be analogous to *S*. However, the failure to observe hyperaccumulation of 186 *O*am particles makes it less likely that *O* is an *S* analog (145).

Recently, Anders and Christie have constructed a plasmid in which transcription of the *K* region of P2 can be induced. Lysis was observed within 30 min after induction (12). The cloned region includes a 1.2-kb segment of the P2 genome, which rescues all known *K*am mutants, plus about 1 kb of adjacent DNA leading up to the distal *R* gene. Partial sequence of the *K* gene has revealed very strong similarity to the λ R transglycosylase gene (12). Finding a gene for a murein-degrading enzyme within a segment of DNA which causes lysis when expressed makes it a reasonably strong prediction that the complete sequence will also reveal a holin gene, probably transcriptionally upstream of *K* and probably similar to either λ *S* or 21 *S*.

Lipid-Containing Phage

The membrane-enveloped RNA phage ϕ 6 lyses its marine host, *Pseudomonas phaseolicola*, at 90 min when the infection is at the normal growth temperature of 28°C (211). This is mildly surprising, since one might expect a virion with a lipid envelope to be extruded from the infected cytoplasm. Mindich and Lehman (213) detected murein hydrolase activity, which they designated as lysin, both in detergent extracts of infected cells and in detergent-solubilized preparations of purified virions. This activity requires the viral protein P5. Mutations in the genes for P5 and for a second protein, P10, fail to cause lysis. Since adding CHCl₃ late in infection causes instantaneous and massive lysis in P10⁻ but not P5⁻ infections, it is thought that P10 (*M_r* \leq 6,000) and P5 (*M_r* \approx 24,000) function in the roles of the λ *S* and *R* proteins,

respectively (210). Incorporation of the lysin into the virion is not required for lysis, since mutants which do not make phage particles still cause lysis if P5 is produced. In the wild-type virion, P5 lysin activity is found between the nucleocapsid and the viral membrane (16, 158). P5⁻ mutants in nonsuppressing cells produce normal amounts of phage which are noninfectious to suppressor bacteria and accumulate in the periplasm (210). This indicates that, after a membrane fusion event has gotten the virion past the outer membrane barrier (255), the capsid-associated P5 is required for penetration of the host murein (213). Since the sequence of the P5 gene fetches up nothing in data base searches, it is unclear whether the predicted 25K basic protein is an amidase, a glycosylase, or some other murein-degrading activity (116). Although the mutant phenotypes indicate that P10 protein serves the same role as λ S in permitting escape of the P5 murein hydrolase, its size (42 residues), hydrophilic N terminus, and hydrophobic C terminus are much more reminiscent of the MS2 L protein (Fig. 8B).

The unrelated *Alteromonas* phage PM2, which has a lipid vesicle surrounding the 10-kbp supercoiled DNA core inside the capsid, also has an endolysin in the mature virion. Tsugakoshi et al. (292) found that a 13K protein attached to the internal membrane of the virion had murein-degrading activity. On the basis of its insolubility in 9 M urea and nonionic detergent, Brewer and Singh (52) concluded that the 13K protein is highly hydrophobic. PM2 causes a sharply defined lysis beginning about 45 min after infection at 30°C (51, 52). Brewer (51) isolated a number of *ts* mutants of PM2, some of which were completely lysis defective. However, all of the lysis-defective mutants failed to form mature virions, suggesting that the lysis protein or proteins of PM2 may have a structural role in the virion or other essential functions in the vegetative cycle. The virion contains four structural proteins, including the 13K murein hydrolase. The gene for the smallest of these proteins, sp6.6, when cloned and expressed in *E. coli*, not only supports the formation of vesicles characteristic of the PM2 morphogenetic pathway but also causes permeabilization of the host membrane (13). The sequence of the *sp6.6* gene predicts a 42-residue polypeptide with a potential transmembrane domain and a multiply charged, hydrophilic C terminus (Fig. 8B). These data suggest that sp6.6 may serve not only as a lysis protein but also as the determinant for organizing the host membrane as a vesicle around the PM2 DNA.

A murein hydrolase can also be detected in lysates and within the virion of the phage PRD1, which has a membrane internal to the capsid like PM2 but has a larger (15-kb) and completely sequenced genome (17). Mindich et al. (212) isolated a collection of nonsense mutants of PRD1 and identified two complementation groups specifically defective in lysis. Cells infected with mutants belonging to complementation group *XV* do not lyse on addition of CHCl₃, fail to synthesize a protein of $M_r \approx 16,000$, and lack the murein hydrolase activity. In contrast, cells infected with mutants from complementation group *A* lyse immediately after CHCl₃ addition and have normal amounts of the hydrolase. Pakula et al. (234) analyzed the sequence of the gene *XV* and found that it encodes a 17.3K product, P15. They found a very limited similarity with phage P22 lysozyme (*gp19*) and a somewhat better match with a short stretch of the λ *Rz* gene. However, the short identity with *gp19* is not very good and does not correspond to the residues conserved among the family of lysozymes. In fact, there is a better match, although still very limited, between P15 and λ *Rz* (234). Thus the nature of the enzymatic identity of P15 is still mysteri-

ous. The murein hydrolase activity was found in sonic extracts cleared of debris, but it is not clear whether the activity assayed is associated with the virion, as is the case with PM2 (212). In any case, there is a stretch of 31 uncharged residues in the middle of the sequence which might serve for localization to the viral internal membrane. SDS-PAGE analysis of cells infected with the PRD1 *A* amber mutant did not show a missing polypeptide species, indicating that either it is expressed at very low levels or it is very small. Inspection of the PRD1 sequence reveals a number of small reading frames encoding hydrophobic polypeptides, any of which would be good candidates for the A lysis protein (17). One reading frame, ORFm, in particular, has a predicted product which resembles other holins in its distribution of charged and hydrophobic residues (Fig. 8A). However, there are some marker rescue data suggesting that ORFm encodes P18, an infectivity protein (17). There is obvious phenotypic resemblance between PRD1 genes *A* and *XV* and the λ *S* and *R* genes, respectively, and so the identification and characterization of the *A* gene should prove very interesting.

Lysis in Phage Infections of Gram-Positive Hosts

Having worked exclusively with *E. coli* and *Salmonella typhimurium*, I have had difficulty fixing on the problem of phage lysis in gram-positive bacteria, whose cultures seem prone to spontaneous lysis after the slightest physiological provocation. This must not be a unique bias because, even compared with the parlous standards established for phages of gram-negative bacteria, next to nothing is known about the lysis mechanisms of phages of gram-positive bacteria. Nevertheless, these phages do lyse their hosts, and some clues to their strategy can be deduced, if somewhat tortuously, from a broad view of the available data. Since host autolysis is so readily induced by physiological conditions in many gram-positive bacteria, we might expect that even large phages might use a lysozyme-independent lysis strategy. In *Streptococcus pneumoniae*, there are two enzymes involved in autolysis, the more important being an *N*-acetylmuramoyl-L-alanine amidase encoded by the *lytA* gene and the other being a glycosidase (152, 262). Agents and conditions known to induce or inhibit autolysis induced by penicillin treatment of *S. pneumoniae* affect the lysis induced by phage Dp-1 in exactly the same way (257), which supports the notion that phage lysis utilizes the autolysis system. Nevertheless, phage-associated lysins are induced by a number of *S. pneumoniae* phages (100, 101, 144). These enzymes are either amidases or glycosidases resembling the host autolysins in size and enzymological properties (100, 256). Both host autolysins and the phage-associated lysin enzymes share the requirement for choline phosphate, which is unique to the teichoic acid of pneumococci (288). Garcia et al. (99) cloned the *cpl* gene, which encodes the 39K soluble glycosidase of pneumococcal phage Cp-1. Sequence analysis of *cpl* and comparison with *lytA* showed that although the N-terminal domains of the two genes are unrelated (as expected, since they encode different enzyme activities), the two genes share more than 50% identity in the C-terminal 142 residues. This suggests that the C terminus defines the cholate recognition domain in both enzymes. Moreover, the gene encoding the amidase of the lysogenic pneumococcal phage HB-3 has been cloned and expressed in *E. coli* (256). The phage amidase is remarkably similar to the pneumococcal *LytA* amidase, as judged by physical and biochemical criteria and N-terminal protein sequencing. These results

make it indisputable that there is an evolutionary relationship between host and phage lytic enzymes, something which has not been demonstrated in gram-negative bacteria. It seems possible that the host autolysins are encoded as part of vestigial or cryptic prophages. In neither host nor phage genes, however, is there evidence for a typical N-terminal signal sequence, which raises the question of how the lytic enzymes escape the cytoplasm and gain access to the cell wall. It is striking that penicillin-induced lysis can be abolished by pretreating pneumococci with choline, trypsin, or anti-LytA antiserum without affecting the 10^4 - to 10^5 -fold loss in viability characteristic of the drug treatment in the absence of such inhibitors (221). This observation suggests that most of the lethality induced by penicillin treatment may reflect a triggering event upstream of amidase action in the lysis pathway. Recently, Moreillon and Tomasz (222) subjected *S. pneumoniae* *lytA* mutants to repeated rounds of penicillin selection and obtained mutants with mutations in a gene they designated *cid*. The *cid* lesion also confers resistance to antibiotics other than the β -lactams, such as vancomycin and cycloserine derivatives (221). These authors speculate that *cid* encodes or controls a protein analogous to λ S which may be involved in pneumococcal autolysis (and, by inference, phage-induced lysis), presumably by causing a membrane lesion through which the amidases and/or glycosidases may pass. *cid* has not yet been characterized at the molecular level, so this remains an attractive and unifying model without much experimental support. Moreover, caution is warranted here because the analogy with the λ S and *R* genes is not perfect. The allelic state of the *R* gene has absolutely no effect on *S* lethality (106), presumably because hole formation is an irreversible and fatal blow to the integrity of the cytoplasmic membrane. In contrast, complete inactivation of *lytA* does reduce penicillin lethality about 10-fold even in a *cid*⁺ background (221). One would have to argue that, unlike S-dependent hole formation, Cid-hole formation is either temporary or repairable in a significant fraction of the cell population.

Shearman et al. (268) constructed a λ gt10 library from an *Alu*I-partial digest of the 23-kbp genome of the bacteriophage ϕ vML3, which grows on *Lactococcus lactis*. Plaques formed from this library on a lawn of *E. coli* were screened by looking for lytic zones in a overlayer of soft agar containing *L. lactis* cells. A region of the ϕ vML3 genome common to positive phages was subcloned into pUC-type plasmids in *E. coli*. This gene is expressed from its own promoter in such plasmid constructs, resulting in production of large amounts of a 21K protein. Extracts of these *E. coli* cells possess strong bacteriolytic activity against *L. lactis*. To test the function of the lysin gene in its natural host, it was subcloned into a shuttle plasmid capable of replication in *L. lactis*. Shuttle constructs with the complete lysin gene could not be transformed into *L. lactis* (but, strangely, *Bacillus subtilis* was permissive). In contrast, shuttle constructs in which the promoter and N-terminal 38 codons of the lysin gene were deleted were fully capable of transformation. The authors conclude that this reflects the predicted lethality of the lysin gene in *L. lactis*. From the perspective of this review, however, one might not expect that a cell-wall-degrading enzyme should be toxic per se, in the absence of a membrane hole former. It is also possible that the failure of the complete clones to transform into *L. lactis* reflects the presence of the intact phage promoter rather than the expression of the lysin gene. The DNA sequence of the lysin gene suggests that, like the pneumococcal phage-associated lysin genes, no signal sequence which could account for

secretion across the cytoplasmic membrane is present. Surprisingly, the only strong sequence similarity found in a search of computer data bases was with gene 15 of the *B. subtilis* phage PZA, a close relative of ϕ 29. Since gene 15 was thought to be involved in PZA/ ϕ 29 capsid morphogenesis (see below), the authors suggest that this unexpected similarity implies dual functions in lysis and in formation of virions for both of these genes. Recently, however, it has been found that PZA/ ϕ 29 15 has sequence similarity to the T4 *e* family of lysozyme genes (see below) and is thus almost certainly a lysin. Inspection of the ϕ vML3 lysin gene sequence reveals that the similarity cited between it and gene 15 is peculiar, since the putative N terminus matches the PZA/ ϕ 29 gene 15 beginning at codon 31 of the latter, which would mean that the ϕ vML3 lysin is missing some of the residues most strongly conserved among the true lysozymes (Fig. 16) and thus cast doubt on the nature of its enzymatic activity (239). However, one can reassign the ribosome-binding site, and, assuming that a single sequencing error has obscured the start codon, generate a reading frame with 29 codons appended upstream. This new reading frame matches the gene 15 sequence very well throughout the N-terminal domain and is in better agreement with the $M_r \approx 24,000$ reported by the authors for the lysin (Fig. 16). Coupled with recent assignment of lysozyme function to the ϕ 29/PZA gene 15 (see below), this interpretation eliminates the need to consider a pleiotropic character for the ϕ vML3 lysin and also establishes the requirement for a holin to effect the release of this phage-encoded murein hydrolase.

Data base searches with the R^{21} lysozyme sequence as a probe revealed that another phage, the temperate phage Hp1, which grows on *Haemophilus influenzae*, had a reading frame with similarities corresponding to the residues most conserved among the lysozyme proteins (239, 322). If our analysis so far has taught anything, it is that any phage with a lysozyme gene should have a holin gene. Although all that is available is the 8-kbp sequence containing the R^{21} homology, it is gratifying to find that there is an ORF immediately upstream of the homologous sequence (Fig. 17). This ORF, containing 78 codons, did not meet the minimum length criterion set by the authors, who reported as potential genes only the nine ORFs longer than 90 codons (20). The predicted amino acid sequence of ORF78 is strikingly reminiscent of the lambdoid and T7 holins, with a similar size, two potential transmembrane domains, and a highly charged C terminus (Fig. 8A). The only disappointing aspect of this sequence analysis is the lack of a consensus Shine-Dalgarno sequence for the lysozyme reading frame, and this may be due to a sequencing error somewhere between the end of the ORF78 putative holin gene and the R^{21} homology (Fig. 17). Correction of the frameshift would leave the Hp1 holin gene stop codon overlapping the start codon of the Hp1 lysozyme gene. Presumably, this proximity implies translational coupling between the two lysis genes, just as in the lambdoid phages (and ϕ 29; see below).

Boizet et al. reasoned that a cloned lysin gene from a *Lactobacillus* phage could be used in the construction of a positive selection vector in lactobacilli (46). Our analysis would suggest that this idea will not work, because positive selection implies a lethal phenotype, which in turn requires the cloning of a holin gene, rather than a lysin. Moreover, screening for plasmid-borne, constitutive expression of a lethal holin gene is at best problematic. Nevertheless, when fragments of the phage mv1 genome were cloned into a plasmid vector and transformed into *E. coli*, clones were identified which produced a lytic halo when spotted onto a

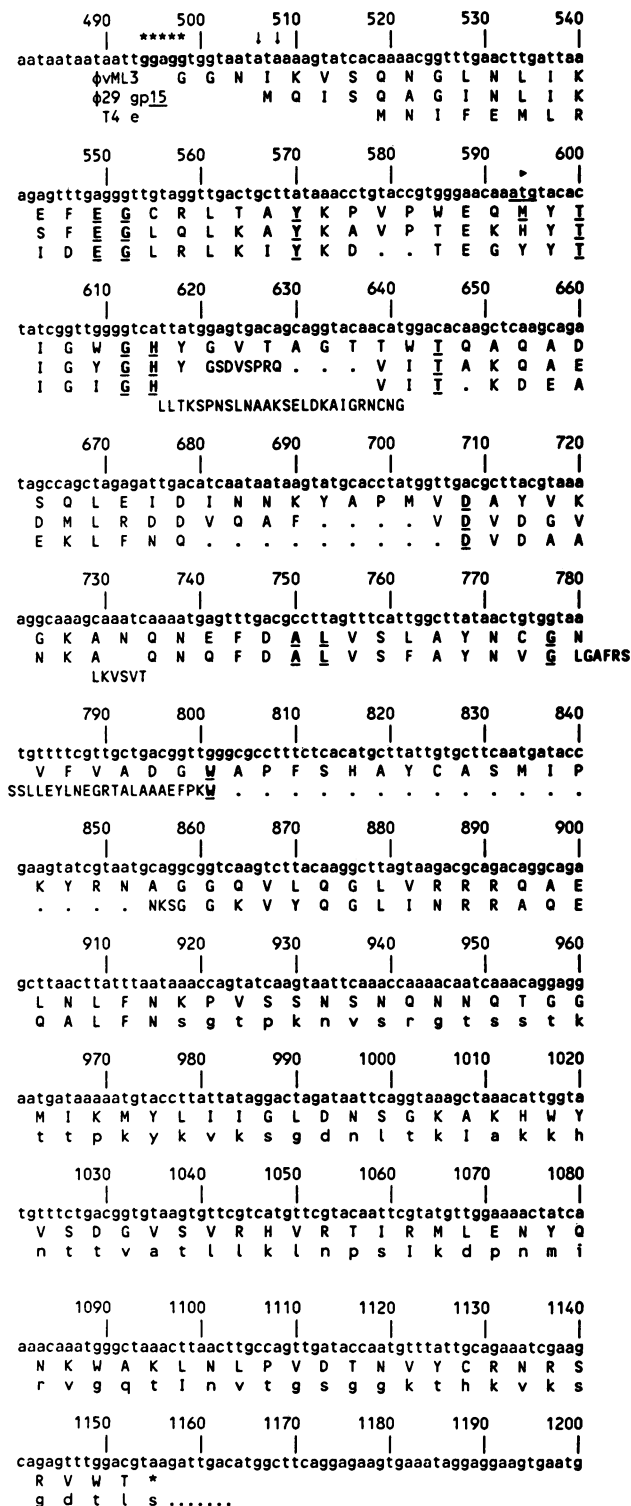

FIG. 16. Sequence of lysin gene of phage ϕ vML3. The nucleotide sequence of a portion of the ϕ vML3 genome is shown in lowercase letters. The first line below the nucleotide sequence shows the reading frame encoding the lysin activity in capitalized single-letter code. The arrowhead above the DNA sequence and the underlined ATG start codon and indicates the start of the lysin gene as proposed by Shearman et al. (268). The partial amino acid sequences of the ϕ 29 P15 lysozyme and the T4 e lysozyme are shown below the ϕ vML3 lysin sequence, with the residues univer-

lawn of *Lactobacillus bulgaricus*. Deletion and sequence analysis revealed that *lysA* was responsible for the lytic activity and had significant sequence similarity to the lysozyme of the streptococcal phage Cp-1. Moreover, its presence increased the plating efficiency of λR^- , but not λS^- , by 10^3 -fold. This clearly identifies LysA as a lysin, or lysozyme. From the perspective of this review, it is somewhat surprising that a plasmid clone of a lysozyme gene should cause the extracellular release of lysozyme activity, as demonstrated by the lytic halo used to identify the *lysA* clone. One possibility is that the cloned DNA fragment also contains a holin gene. However, the smallest segment which maintains the halo phenotype contains only one other gene, a 124-codon reading frame immediately upstream of *lysA*. This cistron, designated *lysB*, bears no resemblance to any member of the holin family but instead has a similar primary sequence architecture, in terms of the array of hydrophobic and charged residues, to ϕ X174 E (Fig. 8B). The halo-producing phenotype persists even if *lysB* is deleted, which suggests that this phenotype may result from nonspecific lysis of a fraction of the colony population rather than the concerted action of lysis genes. The authors note that cells carrying clones of *lysA* grew poorly and were highly susceptible to spontaneous lysis. Why expression of a lysozyme gene should be toxic to *E. coli* is unclear, but it is probably worth noting that a plasmid with an extremely high copy number was used and that the host was a relatively sick *recA* strain.

The notion that viruses of gram-positive bacteria use the holin-lysozyme lysis strategy can also derive support from a consideration of *B. subtilis* phages. A number of phages which utilize this host, especially the virulent, hydroxymethyluracil-containing phage SPO1 and related viruses, have been the subject of intense study with regard to the regulation of gene expression. Despite the well-developed genetics for this large phage (140 kbp, with a virion greater than 250 nm long), the lysis mechanism is still a mystery. Although a lytic enzyme activity can be detected in SPO1 lysates, its induction does not depend on SPO1 infection but instead arises if any DNA is introduced into the host. Mutations in a tail morphogenesis gene, *19*, abolish the induction during phage infection, but it is not clear whether this is a direct effect (281a). The phages ϕ 29 and PZA constitute another class of *B. subtilis* phages, with much smaller genomes (19 kbp), which have been completely sequenced (233, 296). Nonsense mutants with mutations in the essential gene *14*, when grown in a nonsuppressor host, show about a 3-fold increase in lysis time and a 5- to 10-fold increase in phage production (290). If this phenotype is viewed through the prism of the λ or T4 lysis genetics, one would suspect that *gp14* is a holin. The adjacent downstream gene, *15*, encodes a 26K protein which is synthesized at high levels during the ϕ 29/PZA late protein synthesis period (59, 60). Jimenez et al. (169) and Camacho et al. (55) reported that protein 15 had DNA-binding activity and was detectable in proheads but not mature virions, suggesting a role in capsid morphogen-

sally in the T4 lysozyme gene family underlined and in boldface in all three sequences. The distal segment of the ϕ 29 lysin is shown in lowercase letters to signify absence of sequence similarity to the ϕ vML3 lysin sequence. The putative Shine-Dalgarno sequence for a corrected lysin gene is indicated by asterisks, immediately 5' of two vertical arrows which designate where a G nucleotide could be placed to create the extended reading frame.

esis. However, gene 15 turned up in a data base comparison with the R^{21} lysozyme gene of phage 21 (47, 322). When aligned with other members of the gene family (i.e., T4 *e* lysozyme and gp5, the P22 gp19 and 21 gpR), it is clear that protein 15 has all the most conserved residues, including those implicated in substrate binding and catalysis (238, 239). Thus, although there is no report of a phage-induced murein hydrolase activity in ϕ 29/PZA infections, it seems certain that gp15 is a soluble lysozyme and that it passes through gp14 holes to gain access to the cell wall. The structures of gene 14 and its predicted product are provocative on two counts. First, the 131-residue sequence of protein 14 includes an internal region which, when subjected to computer analysis (65, 218), is strongly predicted to be disposed as a pair of transmembrane domains separated by a beta turn (Fig. 8A). Also, the first three codons of ϕ 29 gene 14 are Met-Lys-Met . . . , and there are two consecutive Shine-Dalgarno sequences appropriately spaced upstream, a striking similarity with λ S (Fig. 6). Recently, Bläsi and colleagues have succeeded in obtaining lysis by inducing the expression of tandem 14-15 genes cloned into a plasmid expression vector in *E. coli* (34). Although this work is still very preliminary, it appears that the inducible lysis depends on the integrity of both genes. If this result is confirmed, the analysis of the ϕ 29 14-15 system may at least serve to make the diverse phenomena of phage lysis in gram-positive and gram-negative bacteria a unified problem.

Perspectives

We started with the simple idea that phages might lyse gram-positive hosts by inducing the autolysis phenomenon for which such bacteria are noted. We find, instead, that there are multiple reports of phage-encoded lysins, including those which seem to duplicate the enzymatic activities of the major cellular autolysins (i.e., the amidase and glycosylase activities), as well as true lysozymes. Moreover, for at least the well-characterized ϕ 29/PZA system, it seems clear that the lysis system involves a holin and a soluble lysozyme, just like T4, λ , and other phages of gram-negative bacteria. The lactococcal phage ϕ vML3 encodes a lysozyme very similar to that of ϕ 29, so we expect that there will be a holin gene in ϕ vML3 and, by extension, in other lactococcal and streptococcal phages also. Finally, since the host autolysins appear to be essentially identical to the phage lysins, one is drawn to the hypothesis of Moreillon et al. (221) that the autolysis induced by the lytic antibiotics involves the induction of a host holin gene. Perhaps autolysis is a phenomenon captured from a phage during evolution or still resident on a cryptic host prophage. To say that there are questions remaining is thus an understatement.

HOLIN FAMILY

It seems clear that the dominant motif in phage lysis strategies, for phages of both gram-positive and gram-negative bacteria, is a system based on a murein hydrolase and a second protein required for the access of the hydrolase to its murein substrate. In this review, we have used the term holin for this second protein. Is there really such a functional family, and if so, can analysis of the primary structure reveal anything which is common to the holins? The case is largely circumstantial and indirect. Not counting gp13 and S^{PA-2} since these two proteins are very similar to S and S^{21} , respectively, there are eight different proteins, unrelated in primary sequence, for which there is genetic or physiological

evidence of holin function: S, S^{21} , T7 gp17.5, P1 LydA, ϕ 29 p14, T4 t, and ϕ 6 P10 (Fig. 8). Of these proteins, only S, S^{21} , p14, and P10 have actually been identified as SDS-PAGE bands and only S, p14, and P10 have been shown positively to be membrane proteins in vivo (10, 34, 63, 213). The case for ORF78 of *Haemophilus* phage Hp1 is purely inferential: the reading frame is just upstream of the Hp1 lysozyme gene, and it strongly resembles the S, S^{21} , and gp17.5 proteins in terms of the arrangement of charged and hydrophobic residues. The case for the ORFm of PRD1 is even weaker, since it bears less resemblance to the known holins and has been indirectly implicated in coding for a protein of a different function. It was chosen only because the putative holin gene A has not been mapped or associated with an SDS-PAGE band and ORFm fits better with the S pattern than did six other short reading frames. If we assume that S, S^{21} , gp17.5, LydA, p14, t, and P10 are all holins, is there a common motif in the primary sequences of this group? P10 and t do not resemble the other species at all. It is not surprising that P10 appears different, since, alone among the holins required for release of a murein hydrolase, it is also found in the mature virion (in this case, the lipid of the RNA phage ϕ 6) and may thus be involved not only in lysis but also in infectivity, as is the ϕ 6 murein hydrolase (P10). As was emphasized above, the T4 t holin is the most surprising in terms of its complete dissimilarity to the other known holins. It is possible that the sophisticated regulation imposed by the *r* system on *t* function has driven the divergence of the T4 holin from the others. Alternatively, t may not be a holin but may serve upstream of holin function in T4 lysis, which would leave the true T4 holin gene undiscovered.

Thus, for comparative purposes I shall concentrate on the proteins other than t in the array depicted in Fig. 8A. Easily the most distinctive feature is the presence of an extremely hydrophilic and charge-rich C-terminal domain of 12 to 34 residues. Also, for all these proteins, computer analysis strongly predicts a beta-turn region between the first and second putative intramembrane domains (65, 218). Beta-turn predictions, especially between putative transmembrane domains, may be the most reliable of the Chou-Fasman algorithms applied to membrane proteins, since the turn regions are likely to be disposed in the aqueous phase. In each case, at least two transmembrane domains of 20 or more residues can be predicted, although in every case but S^{21} and S^{PA-2} , it is necessary to include pairs of oppositely charged residues to achieve net charge neutrality within the putative membrane-spanning regions (and, for P1 LydA, the best transmembrane domain, as judged by several different computer algorithms, includes a single, unpaired Glu residue [Fig. 8A]). In several cases, the predicted physical separation of the oppositely charged residues would be too great, assuming an alpha-helical conformation within the membrane, to allow direct salt bridging. This is not a debilitating flaw, since one can invoke a chain of water molecules to bridge the gap (208). Alternatively, and perhaps more attractively in terms of imagining how the holins form holes, the neutralization may be intermolecular rather than intramolecular, providing a driving force for multimerization or channel formation.

If we take the existence of two or more transmembrane domains in all the holins as highly likely, what can we tell about predicted membrane topology? For S^{21} and the very similar S^{PA-2} , there is room for only two transmembrane helical domains in the first 58 residues before the charge-rich C terminus. Hence, the only reasonable way to model S^{21} is as depicted in Fig. 7. The argument for S and gp13, however, is less compelling, and, as discussed above, the preliminary

data from protease accessibility studies suggest that the N terminus may be periplasmic while the C terminus is cytoplasmic. Thus neither of the two configurations for S in Fig. 7 can be eliminated yet. However, gp17.5, ORF78, and p14 each can be drawn with no more than two transmembrane domains, and so the holin family would seem a lot more related if S proves to be disposed with two membrane-embedded segments and the N and C termini in the cytoplasm.

Finally, it is interesting that not only do the two sequence-unrelated classes of lambdoid holins both have dual-start motifs but also the p14 holin from the gram-positive lytic phage $\phi 29$ does. Although the production of two forms of p14 has not been demonstrated, the presence of two adjacent, highly conserved Shine-Dalgarno sequences serving gene 14 suggests that both starts are used in vivo. However, the homologous gene from the closely related phage PZA starts with Met-Thr-Met, rather than the Met-Lys-Met in $\phi 29$ 14, which suggests that the dual starts may not have the same function as in the lambdoid S genes. As mentioned above, Bläsi has found that elimination of the positive charge at residue 6 in S accelerates lysis onset by about as much as removing the Lys-2 positively charged residue (34). Thus the overall positive charge on the N terminus may be important for holin function, with less charge conferring more lethality. Two problems, however, muddle this line of reasoning. First, the uncertainty of whether the N termini of the holins are in the cytoplasm or the more acidic periplasm means that we do not know whether the His residues near the N terminus of S, gp13, and p14 are protonated. Second, it is not known whether the N terminus of any of these holins retains its formyl-methionine after membrane localization. Thus at present we cannot predict the net charge in the N-terminal domain for any holin. This may be an important consideration, especially in light of the powerful influence of such positive charges on the orientation of transmembrane domains (297).

WHY TWO STRATEGIES?

At this late juncture, it seems appropriate to ask why the larger, complex phages have evolved a two (or more)-gene system involving, at least, a murein hydrolase and a holin which functions to allow the escape of the lysozyme across the cytoplasmic membrane. It appears that there would be at least two more direct approaches. First, why not simply equip the murein hydrolase with a signal sequence? The answer is probably that immediate secretion of a murein hydrolase at the onset of the late protein phase would tend toward immediate deterioration of the mechanical integrity of the envelope and thus unacceptable shortening of the vegetative cycle. The second simpler way would be to adopt the single-gene strategy of $\phi X174$ and MS2. (Actually, it is not certain that these two systems share anything except the feature of being composed of single genes, as discussed above.) In other words, why rely on a murein hydrolase at all, when some phages can cause the efficient liberation of progeny virions without elaborating such an activity? If the tunnel model proposed by Witte et al. (313) is correct for $\phi X174$ lysis, perhaps virion size is a determinant. One might argue that such tunnels can attain certain diameters only without using a murein hydrolase to destroy the peptidoglycan. As mentioned above, a λ phage can make small plaques by using the $\phi X174$ E gene in place of the S and R genes. This is weak evidence against the idea that the tunnels have a diameter too small to permit a large, tailed phage to escape.

However, one must remember that plaque-forming ability is often an unreliable phenotype for lysis genes, since the failure of holin function can lead to such a hyperaccumulation of virions that even inefficient, nonspecific lysis can support the formation of a plaque.

Alternatively, the tunnels may not reflect the normal mechanism of $\phi X174$ lysis, which may instead involve a much larger breakage of the sacculus and emergence of an unstable cytoplasmic membrane sac. In this case, phage size seems irrelevant. The $\phi X174$ strategy may not be applicable to other phages, because it seems to require continued growth of the infected cell, presumably to cause the inception of new septal domains, if not actual cell division. In T4 and T7 infections, the host genome is destroyed, so there is no termination of replication and subsequent septal development to serve as a target for a $\phi X174$ -like mechanism. Septation also does not occur during the λ vegetative cycle, as is evident from the observation that infected cells elongate beyond the normal division size before lysis (322). This may be due to the expropriation of host factors essential for initiation or termination of DNA replication, or to something more direct. Even if λ avoided interference with the normal host replication-division system, the λ vegetative cycle is relatively long in comparison with the typical generation time of the host, so a strategy of subverting an incipient septum for the purpose of nucleating a wall lesion would condemn a large fraction of infections to premature lysis. Hence, the large complex phage may have evolved away from a $\phi X174$ -like, septation-dependent lysis mechanism to the ubiquitous holin-lysozyme motif, in which destruction of the envelope can be visited upon the host entirely at the discretion of the virus.

This reasoning is less satisfactory for phages which have gram-positive hosts, since, as discussed above, the cells seem to have mechanisms for both inhibition and massive activation of autolytic enzymes. Yet the limited data available say that these phages use the holin-lysozyme system, and it is even possible that host autolysis itself requires a holin (221, 222).

HORIZONS IN THE STUDY OF LYSIS SYSTEMS

Beyond the self-evident role of the murein hydrolases, the molecular basis of phage lysis is still largely a mystery. The two interesting aspects are the structure of the hole in the cytoplasmic membrane formed by the holins and the mechanism by which the formation of this lesion is regulated during the vegetative phase. To get at these questions, we will have to focus on the structure and function of the holins. Fortunately, the holins possess unsurpassed genetic manipulability. One can usually select spontaneous mutants in vivo simply by requiring that virion production be at least normal (or even improved) and that the virions be retained within the host. Alternatively, these genes can be mounted downstream of tightly controlled promoters in cloning plasmids; selecting for survivors after induction will provide inactivating mutations in the holin, or, possibly, mutations in host genes with which the holin must interact. Mutations which abolish or seriously damage plaque-forming ability when the holin gene is mounted in the phage context can then be subjected to suppression analysis simply by selecting for restoration of the plaque-forming phenotype. Because these genes are so small, they are easy subjects for repetitive sequence analysis, so mutations can be assigned as particular residue changes without preliminary mapping to domains. Moreover, a substantial portion of each protein is

likely to be involved in transmembrane helices and connecting beta turns, for which the secondary-structure constraints may be so severe that mutational and suppression analysis can be very informative. The worst difficulty is actually a mirror image of the same characteristics which make these genes such powerful genetic instruments. These proteins are small, hydrophobic, without enzyme function, and lethal, an array of characteristics not likely to attract legions of biochemists interested in serious physical analysis of structure and function. Enhanced expression of these genes normally results in accelerating the demise of the host bacteria rather than hyperaccumulation of the holin protein. Although the problem of obtaining substantial amounts of a holin may be solved by using fusion gene technology, there is also the problem of designing an *in vitro* system for assaying holin function. However, the system recently devised to study the permeabilization capacity of the MS2 L protein provides hope that this barrier too is not insurmountable.

In terms of regulatory systems, clearly the lambdaoid *S* gene, with the dual-start motif, is currently the most sophisticated, at least in terms of what is understood at the molecular level. There is much to be done with *S*, but it is also clear that there are several other lysis systems, relatively ignored for years, which are inviting targets for molecular analysis. For example, T4 lysis deserves attention, not only because of its role in the history of molecular genetics but also because there are hints that the *r*-mediated negative control of the *t*-encoded holin may reflect an environmental sensor of exquisite sensitivity. More extensive genetic analysis is required before we can discern whether P1 may have evolved a completely distinct mode of lysis control, but the available data suggest that gene 2 encodes a lysis inhibitor required for proper lysis timing.

I believe that the situation is also ripe for great strides with the lysozyme-independent, single-gene systems ϕ X174 *E* and MS2 *L*. Again, it is not clear whether these two lysis genes share any feature, in terms of molecular mechanism, other than acting without a lysozyme activity. *E* and *slyD* may actually be more informative as handles on the cell division process, rather than lysis per se. It is crucial to find whether L acts by interacting with any host proteins, and it is also important to obtain mutant *L* genes to map the important features of this small cistron. Thus a systematic genetic approach to *L* is needed to complement the promising *in vitro* system already established.

At this juncture, having reviewed more than 50 years of work on such a diverse collection of phage systems, I am impressed both with the threads that seem to bind phage lysis phenomena together and with the startling diversity arising from the common motifs. This is, after all, the simplest of developmental events, cell death and disruption programmed into the accumulation and function of one or a few gene products. Biologists, biochemists, and geneticists with interests in many fundamental problems would do well to consider phage lysis genes as model systems with great potential.

ACKNOWLEDGMENTS

This review is dedicated to the memory of Phil Bassford, whose sudden and untimely death has left his friends and colleagues in consternation and shock. Phil was a leader among molecular biologists interested in membrane-protein interactions and protein secretion, among whom I count myself. The list of people who have helped me through this overwhelming undertaking is too long for this space. I am especially grateful to members of my laboratory (Bill Roof, Chung-Yu Chang, Rebecca Johnson-Boaz, and Kiebang

Nam) for their patience and industry and also to all the individuals cited for communication for unpublished results and for their generous suggestions and criticism, especially the following individuals (listed alphabetically) and their coworkers: Udo Bläsi, Gail Christie, Laurence Dupont, Rudi Hausmann, Leonard Mindich, Jeff Roberts, Nat Sternberg, Bill Studier, Jan van Duin, and Kevin Young. The secretarial efforts of Sharyll Pressley were essential and are much appreciated. Photography was done by Biomedical Communications of the College of Medicine, Texas A&M University Health Science Center. Sequence analysis was performed by using the software package PC/Gene (IntelliGenetics, Mountain View, Calif.) on a personal computer and by using the Sequence Analysis Software Package (University of Wisconsin Genetics Computer Group, Madison) on a Vax computer of the Department of Biology.

Work in my laboratory is supported by grants from the National Institutes of Health (PHS grant GM27099) and the Texas Agricultural Experiment Station.

REFERENCES

1. Abedon, S. Personal communication.
2. Abedon, S. T. 1989. Selection for bacteriophage latent period length by bacterial density: a theoretical examination. *Microbiol. Ecol.* **18**:79–88.
3. Abedon, S. T. 1990. Selection for lysis inhibition in bacteriophage. *J. Theor. Biol.* **146**:501–511.
4. Adhin, M. R., A. Avots, V. Berzin, G. P. Overbeek, and J. van Duin. 1990. Complete nucleotide sequence of a group I RNA bacteriophage fr. *Biochim. Biophys. Acta* **1050**:104–109.
5. Adhin, M. R., A. Hirashima, and J. van Duin. 1989. Nucleotide sequence from the ssRNA bacteriophage JP34 resolves the discrepancy between serological and biophysical classification. *Virology* **170**:238–242.
6. Adhin, M. R., and J. van Duin. 1989. Translational regulation of the lysis gene in RNA bacteriophage fr requires a UUG initiation codon. *Mol. Gen. Genet.* **218**:137–142.
7. Adhin, M. R., and J. van Duin. 1990. Scanning model for translational reinitiation in Eubacteria. *J. Mol. Biol.* **213**:811–818.
8. Adhya, S. Personal communication.
9. Adhya, S., A. Sen, and S. Mitra. 1971. The role of gene *S*, p. 743–746. In A. D. Hershey (ed.), *The bacteriophage lambda*. Cold Spring Harbor Laboratory, Cold Spring Harbor, N.Y.
10. Altman, E., R. Altman, M. Garrett, R. Grimaila, and R. Young. 1983. *S* gene product: identification and membrane localization of a lysis control protein. *J. Bacteriol.* **155**:1130–1137.
11. Altman, E., K. Young, J. Garrett, R. Altman, and R. Young. 1985. Subcellular localization of lethal lysis proteins of bacteriophages lambda and ϕ X174. *J. Virol.* **53**:1008–1011.
12. Anders, D., and G. Christie. Unpublished data.
13. Armour, G. A., and G. J. Brewer. 1990. Membrane morphogenesis from cloned fragments of bacteriophage PM2 DNA that contain the sp6.6 gene. *FASEB J.* **4**:1488–1493.
14. Atkins, J. F., J. A. Steitz, C. W. Anderson, and P. Model. 1979. Binding to mammalian ribosomes to MS2 phage RNA reveals an overlapping gene encoding a lysis function. *Cell* **18**:247–256.
15. Bachmann, B. J. 1972. Pedigrees of some mutant strains of *Escherichia coli* K12. *Bacteriol. Rev.* **36**:525–557.
16. Bamford, D. H., and E. T. Palva. 1980. Structure of the lipid-containing bacteriophage ϕ 6: disruption by triton X-100 treatment. *Biochim. Biophys. Acta* **601**:245–259.
17. Bamford, J. K. H., A.-L. Hänninen, T. M. Päkula, P. M. Ojala, N. Kalkkinen, M. Frilander, and D. H. Bamford. 1991. Genome organization of membrane-containing bacteriophage PRD1. *Virology* **183**:658–676.
18. Barik, S., and N. C. Mandal. 1982. Role of *S* gene product of bacteriophage lambda in host cell lysis. *J. Biosci.* **4**:361–368.
19. Barrell, B. G., G. M. Air, and C. A. Hutchison III. 1976. Overlapping genes in bacteriophage ϕ X174. *Nature (London)* **264**:34–41.
20. Benjamin, R. C., W. P. Fitzmaurice, P. C. Huang, and J. J. Scocca. 1984. Nucleotide sequence of cloned DNA segments of

- the *Haemophilus influenzae* bacteriophage HP1c1. *Gene* **31**: 173-185.
21. Bennett, J., J. Glavinovich, R. Liskay, D. L. Wulff, and J. E. Cronan, Jr. 1971. Phospholipid hydrolysis in *Escherichia coli* infected with rapid lysis mutants of phage T4. *Virology* **43**:516-518.
 22. Benzer, S. 1957. The elementary units of heredity, p. 70-93. In B. Glass (ed.), *The chemical basis of heredity*. The John Hopkins Press, Baltimore.
 23. Benzer, S. 1966. Adventures in the *rII* region, p. 157-165. In J. Cairns, G. S. Stent, and J. D. Watson (ed.), *Phage and the origins of molecular biology*. Cold Spring Harbor Laboratory, Cold Spring Harbor, N.Y.
 24. Beremand, M. N., and T. Blumenthal. 1979. Overlapping genes in RNA phage: a new protein implicated in lysis. *Cell* **18**:257-266.
 25. Berkhout, B. 1986. Translational control mechanisms in RNA bacteriophage MS2. Ph.D. thesis. Leiden University, Leiden, The Netherlands.
 26. Berkhout, B., M. H. de Smit, R. A. Spanjaard, T. Blom, and J. van Duin. 1985. The amino terminal half of the MS2-coded lysis protein is dispensable for function: implications for our understanding of coding region overlaps. *EMBO J.* **4**:3315-3320.
 27. Berkhout, B., R. A. Kastelein, and J. van Duin. 1985. Translational interference at overlapping reading frames in prokaryotic messenger RNA. *Gene* **37**:171-179.
 28. Berkhout, B., B. F. Schmidt, A. van Strien, J. van Boom, J. van Westrenen, and J. van Duin. 1987. Lysis gene of bacteriophage MS2 is activated by translation termination at the overlapping coat gene. *J. Mol. Biol.* **195**:517-524.
 29. Berkhout, B., C. J. van der Laken, and P. H. van Knippenberg. 1986. Formylmethionyl-tRNA binding to 30S ribosomes programmed with homopolynucleotides and the effect of translational initiation factor 3. *Biochim. Biophys. Acta* **866**:144-153.
 30. Bertani, G. 1951. Studies on lysogenesis. I. The mode of phage liberation by lysogenic *Escherichia coli*. *J. Bacteriol.* **62**:293-300.
 31. Bertani, L. E., and E. W. Six. 1988. The P2-like phages and their parasite, P4, p. 73-143. In R. Calendar (ed.), *The bacteriophages*. Plenum Press, New York.
 32. Bienkowska-Szewczyk, K., B. Lipinska, and A. Taylor. 1981. The *R* gene product of bacteriophage lambda is the murein transglycosylase. *Mol. Gen. Genet.* **184**:111-114.
 33. Blasband, A. J., W. R. Marcotte, Jr., and C. A. Schnaitman. 1986. Structure of the *lc* and *nmpC* outer membrane porin protein genes of lambda bacteriophage. *J. Biol. Chem.* **261**:12723-12732.
 34. Bläsi, U. Personal communication.
 35. Bläsi, U., C.-Y. Chang, and R. Young. Unpublished data.
 36. Bläsi, U., C.-Y. Chang, M. T. Zagotta, K. Nam, and R. Young. 1990. The lethal lambda *S* gene encodes its own inhibitor. *EMBO J.* **9**:981-989.
 37. Bläsi, U., R. Geisen, W. Lubitz, B. Henrich, and R. Plapp. 1983. Localisation of the bacteriophage phiX174 lysis gene product in the cell envelope of *Escherichia coli*, p. 205-210. In R. Hakenbeck, J.-V. Höltje, and H. Labischinski (ed.), *The target of penicillin*. Walter de Gruyter, Berlin.
 38. Bläsi, U., B. Henrich, and W. Lubitz. 1985. Lysis of *Escherichia coli* by cloned phiX174 gene *E* depends on its expression. *J. Gen. Microbiol.* **131**:1107-1114.
 39. Bläsi, U., R. P. Linke, and W. Lubitz. 1989. Evidence for membrane-bound oligomerization of bacteriophage phiX174 lysis protein-E. *J. Biol. Chem.* **264**:4552-4558.
 40. Bläsi, U., and W. Lubitz. 1985. Influence of C-terminal modifications of phiX174 lysis gene *E* on its lysis-inducing properties. *J. Gen. Virol.* **66**:1209-1213.
 41. Bläsi, U., K. Nam, D. Hartz, L. Gold, and R. Young. 1989. Dual translational initiation sites control function of the lambda *S* gene. *EMBO J.* **8**:3501-3510.
 42. Bläsi, U., K. Nam, W. Lubitz, and R. Young. 1990. Translational efficiency of phiX174 lysis gene *E* is unaffected by upstream translation of the overlapping gene *D* reading frame. *J. Bacteriol.* **172**:5617-5623.
 43. Bläsi, U., R. Young, and W. Lubitz. 1988. Evaluation of phiX174 gene products E and K in E-mediated lysis of *Escherichia coli*. *J. Virol.* **62**:4362-4364.
 44. Blattner, F. R., and J. E. Dahlberg. 1972. RNA synthesis start-points in bacteriophage lambda: are the promoter and operator transcribed? *Nature (London) New Biol.* **237**:227-232.
 45. Bode, W. 1967. Lysis inhibition in *Escherichia coli* infected with bacteriophage T4. *J. Virol.* **1**:948-955.
 46. Boizet, B., Y. Lahbib-Mansais, L. Dupont, P. Ritzenthaler, and M. Mata. 1990. Cloning, expression, and sequence analysis of an endolysin-encoding gene of *Lactobacillus bulgaricus* bacteriophage mv1. *Gene* **94**:61-67.
 47. Bonovich, M. T., and R. Young. 1991. Dual start motif in two lambdaoid *S* genes unrelated to lambda *S*. *J. Bacteriol.* **173**:2897-2905.
 48. Botstein, D. 1980. A theory of modular evolution for bacteriophages. *Ann. N.Y. Acad. Sci.* **354**:484-490.
 49. Bradley, D. E. 1968. Spheroplast formation in cells of *Escherichia coli* infected with a phiX174 type bacteriophage. *J. Gen. Virol.* **3**:141-142.
 50. Bradley, D. E., C. A. Dewar, and D. Robertson. 1969. Structural changes in *Escherichia coli* infected with a phiX174 type bacteriophage. *J. Gen. Virol.* **5**:113-121.
 51. Brewer, G. J. 1978. Characterization of temperature-sensitive mutants of bacteriophage PM2: membrane mutants. *Mol. Gen. Genet.* **167**:65-74.
 52. Brewer, G. J., and M. Singh. 1982. Kinetics and characterization of the proteins synthesized during infection by bacteriophage PM2. *J. Gen. Virol.* **60**:135-146.
 53. Buckley, K. J., and M. Hayashi. 1986. Lytic activity localized to membrane-spanning region of phiX174 E protein. *Mol. Gen. Genet.* **204**:120-125.
 54. Buckley, K. J., and M. Hayashi. 1987. Role of premature translation termination in the regulation of expression of the phiX174 lysis gene. *J. Mol. Biol.* **198**:599-607.
 55. Camacho, A., F. Jimenez, J. de la Torre, J. L. Carrascosa, R. P. Mellado, C. Vasquez, E. Vinuela, and M. Salas. 1977. Assembly of *Bacillus subtilis* phage phi29. Mutants of the cistrons coding for the structural proteins. *Eur. J. Biochem.* **73**:39-55.
 56. Campbell, A., and D. Botstein. 1983. Evolution of the lambdaoid phages, p. 365-380. In R. W. Hendrix, J. W. Roberts, R. W. Stahl, and R. A. Weisberg (ed.), *Lambda II*. Cold Spring Harbor Laboratory, Cold Spring Harbor, N.Y.
 57. Campbell, A., and A. D. Campillo-Campbell. 1963. Mutant of bacteriophage lambda producing a thermolabile endolysin. *J. Bacteriol.* **85**:1202-1207.
 58. Campbell, J. H., and B. G. Rolfe. 1975. Evidence for a dual control of the initiation of host-cell lysis caused by phage lambda. *Mol. Gen. Genet.* **139**:1-8.
 59. Carrascosa, J. L., A. Camacho, F. Jimenez, R. P. Mellado, E. Vinuela, and M. Salas. 1976. *Bacillus subtilis* phage phi29. Characterization of gene products and functions. *Eur. J. Biochem.* **66**:229-241.
 60. Carrascosa, J. L., E. Vinuela, and M. Salas. 1973. Proteins induced in *B. subtilis* infected with bacteriophage phi29. *Virology* **56**:291-299.
 61. Casjens, S., K. Eppler, R. Parr, and A. R. Potete. 1989. Nucleotide sequence of the bacteriophage P22 gene 19 to 3 region: identification of a new gene required for lysis. *Virology* **171**:588-598.
 62. Champe, S. P. 1963. Bacteriophage reproduction. *Annu. Rev. Microbiol.* **17**:87-114.
 63. Chang, C.-Y., and R. Young. Unpublished data.
 64. Chou, P. Y., and G. D. Fasman. 1978. Empirical predictions of protein conformation. *Annu. Rev. Biochem.* **47**:251-276.
 65. Chou, P. Y., and G. D. Fasman. 1979. Prediction of beta-turns. *Biophys. J.* **26**:367-384.
 66. Cody, J. D. M., and T. W. Conway. 1981. Leakage induced in *Escherichia coli* cells by A protein-RNA complexes from bacteriophage f2. *J. Virol.* **39**:60-66.
 67. Cody, J. D. M., and T. W. Conway. 1981. Defective lysis of streptomycin-resistant *Escherichia coli* cells infected with bac-

- terioophage f2. *J. Virol.* **37**:813–820.
68. Coleman, J., M. Inouye, and J. Atkins. 1983. Bacteriophage MS2 lysis protein does not require coat protein to mediate cell lysis. *J. Bacteriol.* **153**:1098–1100.
 69. Cone, K. C., and D. A. Steege. 1985. Messenger RNA conformation and ribosome selection of translational reinitiation sites in the *lac* repressor mRNA. *J. Mol. Biol.* **186**:725–732.
 70. Creighton, T. E. 1984. Proteins, p. 268. W. H. Freeman & Co., New York.
 71. Cronan, J. E., Jr., and D. L. Wulff. 1969. A role for phospholipid hydrolysis in the lysis of *Escherichia coli* infected with bacteriophage T4. *Virology* **38**:241–246.
 72. Dabora, R. L., and C. L. Cooney. 1990. Intracellular lytic enzyme systems and their use for disruption of *Escherichia coli*. *Adv. Biochem. Eng. Biotechnol.* **43**:11–30.
 73. Daegelen, P., and E. Brody. 1990. The *rIIA* gene of bacteriophage T4. I. Its DNA sequence and discovery of a new open reading frame between genes 60 and *rIIA*. *Genetics* **125**:237–248.
 74. Dai, D., and E. E. Ishiguro. 1990. Two new mutant loci (*smhB* and *lytD*) in *Escherichia coli* which confer temperature-sensitive growth and lysis phenotypes. *Can. J. Microbiol.* **36**:827–833.
 75. Daniels, D. L., J. L. Schroeder, W. Szybalski, F. Sanger, and F. R. Blattner. 1983. Appendix I. A molecular map of coliphage lambda, p. 469–517. In R. W. Hendrix, J. W. Roberts, F. W. Stahl, and R. A. Weisberg (ed.), *Lambda II*. Cold Spring Harbor Laboratory, Cold Spring Harbor, N.Y.
 76. Daniels, D. L., J. L. Schroeder, W. Szybalski, F. Sanger, A. R. Coulson, G. R. Hong, D. F. Hill, G. B. Petersen, and F. R. Blattner. 1983. Appendix II: Complete annotated lambda sequence, p. 519–676. In R. W. Hendrix, J. W. Roberts, F. W. Stahl, and R. A. Weisberg (ed.), *Lambda II*. Cold Spring Harbor Laboratory, Cold Spring Harbor, N.Y.
 77. Daniels, D. L., M. N. Subbarao, F. R. Blattner, and H. A. Lozeron. 1988. Q-mediated late gene transcription of bacteriophage lambda: RNA start point and RNase III processing sites in vivo. *Virology* **167**:568–577.
 78. de Boer, P. A. J., W. R. Cook, and L. I. Rothfield. 1990. Bacterial cell division. *Annu. Rev. Genet.* **24**:249–274.
 79. Delbrück, M. 1940. The growth of bacteriophage and lysis of the host. *J. Gen. Physiol.* **23**:643–660.
 80. DeLong, A., and M. Syvanen. 1990. Membrane association of the Tnp and Inh proteins of IS50R. *J. Bacteriol.* **172**:5516–5519.
 81. Denhardt, D. T., and R. L. Sinsheimer. 1965. The process of infection with bacteriophage ϕ X174. III. Phage maturation and lysis after synchronized infection. *J. Mol. Biol.* **12**:641–646.
 82. Doermann, A. H. 1948. Lysis and lysis inhibition with *Escherichia coli* bacteriophage. *J. Bacteriol.* **55**:257–276.
 83. Doermann, A. H. 1952. The intracellular growth of bacteriophages. I. Liberation of intracellular bacteriophage T4 by premature lysis with another phage or with cyanide. *J. Gen. Physiol.* **35**:645–656.
 84. Dove, W. F. 1971. Biological inferences, p. 297–312. In A. D. Hershey (ed.), *The bacteriophage lambda*. Cold Spring Harbor Laboratory, Cold Spring Harbor, N.Y.
 85. Dunn, J. J., and F. W. Studier. 1983. Complete nucleotide sequence of bacteriophage T7 DNA and the locations of T7 genetic elements. *J. Mol. Biol.* **166**:477–535.
 86. Eigner, J., A. H. Stouthamer, I. van der Sluys, and J. A. Cohen. 1963. A study of the 70S component of bacteriophage ϕ X174. *J. Mol. Biol.* **6**:61–84.
 87. Emrich, J. 1968. Lysis of T4-infected bacteria in the absence of lysozyme. *Virology* **35**:158–165.
 88. Emrich, J., and G. Streisinger. 1968. The role of phage lysozyme in the life cycle of phage T4. *Virology* **36**:387–391.
 89. Engleberg, H., and E. Soudry. 1971. Ribonucleic acid bacteriophage release: requirement for host-controlled protein synthesis. *J. Virol.* **8**:257–264.
 90. Ennis, H. L., and K. D. Kievitt. 1973. Association of the *rIIA* protein with the bacterial membrane. *Proc. Natl. Acad. Sci. USA* **70**:1468–1472.
 91. Ennis, H. L., and K. D. Kievitt. 1977. Alteration of the *Escherichia coli* membrane by addition of bacteriophage T4 proteins synthesized after infection. *J. Virol.* **22**:553–560.
 92. Faelen, M., and A. Toussaint. 1973. Isolation of conditional defective mutants of temperate phage Mu-1 and deletion mapping of the Mu-1 prophage. *Virology* **54**:117–124.
 93. Fasman, G. D., and W. A. Gilbert. 1990. The prediction of transmembrane protein sequences and their conformation: an evaluation. *Trends Biochem. Sci.* **15**:89–92.
 94. Fiers, W., R. Contreras, F. Duerinck, G. Haegeman, D. Ise-mentant, J. Merregaert, W. M. Jou, F. Molemans, A. Raeymaekers, A. Van den Berghe, G. Volckaert, and M. Ysebert. 1976. Complete nucleotide sequence of bacteriophage MS2 RNA primary and secondary structure of the replicase gene. *Nature (London)* **260**:500–507.
 95. Fromageot, H. P. M., and N. D. Zinder. 1968. Growth of bacteriophage f2 in *E. coli* treated with rifampicin. *Proc. Natl. Acad. Sci. USA* **61**:184–191.
 96. Froshauer, S., G. N. Green, D. Boyd, K. McGovern, and J. Beckwith. 1988. Genetic analysis of the membrane insertion and topology of MalF, a cytoplasmic membrane protein of *Escherichia coli*. *J. Mol. Biol.* **200**:501–511.
 97. Galvez, A., E. Valdivia, M. Maqueda, and E. Montoya. 1985. Production of bacteriocin-like substances by group D streptococci of human origin. *Microbios* **43**:223–232.
 98. Ganz, T. 1988. Neutrophils and host defense. *Ann. Intern. Med.* **109**:127–142.
 99. Garcia, E., J. L. Garcia, P. Garcia, A. Arraras, J. M. Sanchez-Puelles, and R. Lopez. 1988. Molecular evolution of lytic enzymes of *Streptococcus pneumoniae* and its bacteriophages. *Proc. Natl. Acad. Sci. USA* **85**:914–918.
 100. Garcia, J. L., E. Garcia, A. Arraras, P. Garcia, C. Ronda, and R. Lopez. 1987. Cloning, purification and biochemical characterization of the pneumococcal bacteriophage Cp-1 lysin. *J. Virol.* **61**:2573–2580.
 101. Garcia, P., R. Lopez, C. Ronda, E. Garcia, and A. Tomasz. 1983. Mechanism of phage-induced lysis in pneumococci. *J. Gen. Microbiol.* **129**:479–487.
 102. Garen, A. 1961. Physiological effects of *rII* mutations in bacteriophage T4. *Virology* **14**:151–163.
 103. Garnier, J., D. J. Osguthorpe, and B. Robson. 1978. Analysis of the accuracy and implications of simple methods for predicting the secondary structure of globular proteins. *J. Mol. Biol.* **120**:97–120.
 104. Garrett, J., C. Bruno, and R. Young. 1990. Lysis protein S of phage lambda functions in *Saccharomyces cerevisiae*. *J. Bacteriol.* **172**:7275–7277.
 105. Garrett, J., R. Fusselman, J. Hise, L. Chiou, D. Smith-Grillo, R. Schulz, and R. Young. 1981. Cell lysis by induction of cloned lambda lysis genes. *Mol. Gen. Genet.* **182**:326–331.
 106. Garrett, J., and R. Young. 1982. Lethal action of bacteriophage lambda S gene. *J. Virol.* **44**:886–892.
 107. Georgiou, C. D., T. J. Dueweke, and R. B. Gennis. 1988. Beta-galactosidase gene fusions as probes for the cytoplasmic regions of subunits I and II of the membrane-bound cytochrome d terminal oxidase from *Escherichia coli*. *J. Biol. Chem.* **263**:13130–13137.
 108. Gillam, S., T. Atkinson, A. Markham, and M. Smith. 1985. Gene K of bacteriophage ϕ X174 codes for a protein which affects the burst size of phage production. *J. Virol.* **53**:708–709.
 109. Godson, G. N., J. C. Fiddes, B. G. Barrell, and F. Sanger. 1978. Comparative DNA sequence analysis of the G4 and ϕ X174 genomes, p. 51–86. In D. T. Denhardt, D. Dressler, and D. S. Ray (ed.), *The single-stranded DNA phages*. Cold Spring Harbor Laboratory, Cold Spring Harbor, N.Y.
 110. Goessens, W. H. F., A. J. M. Driessen, J. Wilschut, and J. van Duin. 1988. A synthetic peptide corresponding to the C-terminal 25 residues of phage MS2 coded lysis protein dissipates the proton-motive force in *Escherichia coli* membrane vesicles by generating hydrophilic pores. *EMBO J.* **7**:867–873.
 111. Goldberg, A. R., and M. Howe. 1969. New mutations in the S cistron of bacteriophage lambda affecting host cell lysis. *Virology* **38**:200–202.
 112. Goliger, J. A., and J. W. Roberts. 1989. Sequences required for

- antitermination by phage 82 Q protein. *J. Mol. Biol.* **210**:461–471.
113. Goodell, E. W., R. Lopez, and A. Tomasz. 1976. Suppression of lytic effect of beta lactams on *Escherichia coli* and other bacteria. *Proc. Natl. Acad. Sci. USA* **73**:3293–3297.
 114. Gorini, L. 1974. Streptomycin and misreading of the genetic code, p. 791–803. *In* M. Nomura, A. Tissieres, and P. Lengyel (ed.), *Ribosomes*. Cold Spring Harbor Laboratory, Cold Spring Harbor, N.Y.
 115. Gottesman, M. Personal communication.
 116. Gottlieb, P., S. Metzger, M. Romantschuk, J. Carton, J. Strassman, D. H. Bamford, N. Kalkkinen, and L. Mindich. 1988. Nucleotide sequence of the middle dsRNA segment of bacteriophage $\phi 6$: placement of the genes of membrane-associated proteins. *Virology* **163**:183–190.
 117. Groman, N. B., and G. Suzuki. 1966. Effect of spermine on lysis and reproduction by bacteriophages $\phi X174$, λ , and $\phi 2$. *J. Bacteriol.* **92**:1735–1740.
 118. Grütter, M. G., L. H. Weaver, T. M. Gray, and B. W. Matthews. 1983. Structure, function, and evolution of the lysozyme from bacteriophage T4, p. 356–360. *In* C. K. Matthews, E. M. Kutter, G. Mosig, and P. B. Berget (ed.), *Bacteriophage T4*. American Society for Microbiology, Washington, D.C.
 119. Gschwendter, H. H., and P. H. Hofschneider. 1969. Lysis inhibition of $\phi X174$, M12, and Q β -infected *Escherichia coli* bacteria by magnesium ions. *Biochim. Biophys. Acta* **190**:454–459.
 120. Gualerzi, C., C. L. Pon, and A. Kaji. 1971. Initiation factor dependent release of aminoacyl tRNAs from complexes of 30S ribosomal subunits, synthetic polynucleotide and aminoacyl tRNA. *Biochem. Biophys. Res. Commun.* **45**:1312–1319.
 121. Guidolin, A., J.-M. Zingg, H. Lehnher, and W. Arber. 1989. Bacteriophage P1 tail-fibre and *dar* operons are expressed from homologous phage-specific late promoter sequences. *J. Mol. Biol.* **208**:615–622.
 122. Guo, H.-C., M. Kainz, and J. W. Roberts. 1991. Characterization of the late-gene regulatory region of phage 21. *J. Bacteriol.* **173**:1554–1560.
 123. Hall, J. E., I. Vodyanoy, T. M. Balasubramanian, and G. R. Marshall. 1984. Alamethicin, a rich model for channel behavior. *Biophys. J.* **45**:233–247.
 124. Hall, M. N., J. Gabay, M. Debarbouille, and M. Schwartz. 1982. A role for mRNA secondary structure in the control of translation initiation. *Nature (London)* **295**:616–618.
 125. Hardaway, K. L., M. V. Maten, and C. S. Buller. 1975. Phospholipase activity in bacteriophage-infected *Escherichia coli*. III. Phospholipase A involvement in lysis of T4-infected cells. *J. Virol.* **16**:867–871.
 126. Harkness, R. E., and E. E. Ishiguro. 1983. Temperature-sensitive autolysis-defective mutants of *Escherichia coli*. *J. Bacteriol.* **155**:15–21.
 127. Harkness, R. E., and W. Lubitz. 1987. Construction and properties of a chimeric bacteriophage lysis gene. *FEMS Microbiol. Lett.* **48**:19–24.
 128. Harris, A. W., D. W. A. Mount, C. R. Fuerst, and L. Siminovich. 1967. Mutations in bacteriophage lambda affecting host cell lysis. *Virology* **32**:553–569.
 129. Hartz, D., D. S. McPheeters, R. Traut, and L. Gold. 1988. Extension inhibition analysis of translation initiation complexes. *Methods Enzymol.* **164**:419–425.
 130. Hausmann, R. Personal communication.
 131. Hausmann, R. 1976. Bacteriophage T7 genetics. *Curr. Top. Microbiol. Immunol.* **75**:77–110.
 132. Hausmann, R. 1988. The T7 group, p. 259–289. *In* R. Calendar (ed.), *The bacteriophages*. Plenum Press, New York.
 133. Hayashi, M. Personal communication.
 134. Hayashi, M. N., and M. Hayashi. 1981. Stability of bacteriophage $\phi X174$ -specific mRNA in vivo. *J. Virol.* **37**:506–510.
 135. Heagy, F. 1950. The effect of 2,4-dinitrophenol and phage T2 on *Escherichia coli*. *J. Bacteriol.* **59**:367–375.
 136. Henning, U. Personal communication.
 137. Henrich, B., W. Lubitz, and R. Plapp. 1982. Lysis of *Escherichia coli* by induction of cloned $\phi X174$ genes. *Mol. Gen. Genet.* **185**:493–497.
 138. Henrich, B., W. Lubitz, and R. Plapp. 1983. Expression of $\phi X174$ lysis gene cloned into different plasmids, p. 197–203. *In* R. Hakenbeck, J.-V. Höltje, and H. Labischinski (ed.), *The target of penicillin*. Walter de Gruyter, Berlin.
 139. Herriott, R. M., and J. L. Barlow. 1957. The protein coats or “ghosts” of coli phage T2. II. The biological functions. *J. Gen. Physiol.* **41**:307–331.
 140. Hershey, A. D. 1946. Mutation of bacteriophage with respect to type of plaque. *Genetics* **31**:620–640.
 141. Hershey, A. D. 1946. Spontaneous mutations in bacterial viruses. *Cold Spring Harbor Symp. Quant. Biol.* **11**:67–77.
 142. Hershey, A. D., and R. Rotman. 1948. Linkage among genes controlling inhibition of lysis in a bacterial virus. *Proc. Natl. Acad. Sci. USA* **34**:89–96.
 143. Herskowitz, I., and E. R. Signer. 1970. A site essential for expression of all late genes in bacteriophage lambda. *J. Mol. Biol.* **45**:545–556.
 144. Hill, J. E., and L. W. Wannamaker. 1981. Identification of a lysin associated with a bacteriophage (A25) virulent for group A streptococci. *J. Bacteriol.* **145**:696–703.
 145. Hocking, S. M., and J. B. Egan. 1982. Genetic studies of coliphage 186. II. Genes associated with phage replication and host cell lysis. *J. Virol.* **44**:1068–1071.
 146. Hoffmann-Berling, H., and R. Mazé. 1964. Release of male-specific bacteriophages from surviving host bacteria. *Virology* **22**:305–313.
 147. Höltje, J.-V., W. Fiedler, H. Roterger, B. Walderich, and J. van Duin. 1988. Lysis induction of *Escherichia coli* by the cloned lysis protein of the phage MS2 depends on the presence of osmoregulatory membrane-derived oligosaccharides. *J. Biol. Chem.* **263**:3539–3541.
 148. Höltje, J.-V., and E. I. Tuomanen. 1991. The murein hydrolases of *Escherichia coli*: properties, functions and impact on the course of infections in vivo. *J. Gen. Microbiol.* **137**:441–454.
 149. Höltje, J.-V., and J. van Duin. 1984. MS2 phage induced lysis of *E. coli* depends on the activity of the bacterial autolysins, p. 195–199. *In* C. Nombela (ed.), *Microbial cell wall synthesis and autolysis*. Elsevier Science Publishers, Amsterdam.
 150. Hooper, I., W. H. Woods, and B. Egan. 1981. Coliphage 186 replication is delayed when the host cell is UV irradiated before infection. *J. Virol.* **40**:341–349.
 151. Howard, B. D. 1967. Phage lambda mutants deficient in *rII* exclusion. *Science* **158**:1588–1589.
 152. Howard, L. V., and H. Gooder. 1974. Specificity of the autolysis of *Streptococcus (Diplococcus) pneumoniae*. *J. Bacteriol.* **117**:796–804.
 153. Huang, W. M. 1975. Membrane-associated proteins of T4-infected *Escherichia coli*. *Virology* **66**:508–521.
 154. Huang, W. M. 1986. The 52-protein subunit of T4 DNA topoisomerase is homologous to the *gyrA*-protein of gyrase. *Nucleic Acids Res.* **14**:7379–7390.
 155. Huang, W. M., and J. M. Buchanan. 1974. Synergistic interactions of T4 early proteins concerned with their binding to DNA. *Proc. Natl. Acad. Sci. USA* **71**:2226–2230.
 156. Hutchison, C. A., III, and R. L. Sinsheimer. 1963. Kinetics of bacteriophage release by single cells of $\phi X174$ -infected *E. coli*. *J. Mol. Biol.* **7**:206–208.
 157. Hutchison, C. A., III, and R. L. Sinsheimer. 1966. The process of infection with bacteriophage $\phi X174$. X. Mutations in a ϕX lysis gene. *J. Mol. Biol.* **18**:429–447.
 158. Iba, H., M. Nanno, H. Katitani, Y. Emori, and Y. Okada. 1981. A lytic enzyme in the bacteriophage $\phi 6$ virion, p. 491–502. *In* M. S. DuBow (ed.), *Bacteriophage assembly*. Alan R. Liss, Inc., New York.
 159. Iida, K., Y. Hirota, and U. Schwarz. 1983. Mutants of *Escherichia coli* defective in penicillin-insensitive murein DD-endopeptidase. *Mol. Gen. Genet.* **189**:215–221.
 160. Iida, S. Unpublished data.
 161. Iida, S., and W. Arber. 1977. Plaque forming specialized transducing phage P1: isolation of P1CmSmSu, a precursor of P1Cm. *Mol. Gen. Genet.* **153**:259–269.
 162. Iida, S., and N. Sternberg. Unpublished data.

163. Imada, M., and A. Tsugita. 1971. Amino-acid sequence of lambda phage endolysin. *Nature (London) New Biol.* **233**:230-231.
164. Inouye, M., N. Arnheim, and R. Sternglanz. 1973. Bacteriophage T7 lysozyme is an N-acetylmuramyl-L-alanine amidase. *J. Biol. Chem.* **248**:7247-7252.
165. Isberg, R. R., A. L. Lazaar, and M. Syvanen. 1982. Regulation of Tn5 by the right-repeat proteins: control at the level of the transposition reaction? *Cell* **30**:883-892.
166. Isberg, R. R., and M. Syvanen. 1985. Compartmentalization of the proteins encoded by IS50R. *J. Biol. Chem.* **260**:3645-3651.
167. Jacob, F., and C. R. Fuerst. 1958. The mechanism of lysis by phage studied with defective lysogenic bacteria. *J. Gen. Microbiol.* **18**:518-526.
168. Jahnig, F. 1990. Structure predictions of membrane proteins are not that bad. *Trends Biochem. Sci.* **15**:93-95.
169. Jimenez, F., A. Camacho, J. de la Torre, E. Vinuela, and M. Salas. 1977. Assembly of *Bacillus subtilis* phage ϕ 29. 2. Mutants in the cistrons coding for the non-structural proteins. *Eur. J. Biochem.* **73**:57-72.
170. Johnson-Boaz, R., and R. Young. Unpublished data.
171. Johnston, H. M., and J. R. Roth. 1981. DNA sequence changes of mutations altering attenuation control of the histidine operon of *Salmonella typhimurium*. *J. Mol. Biol.* **145**:735-756.
172. Josslin, R. 1970. The lysis mechanism of phage T4: mutants affecting lysis. *Virology* **40**:719-726.
173. Josslin, R. 1971. Physiological studies of the *t* gene defect in T4-infected *Escherichia coli*. *Virology* **44**:101-107.
174. Josslin, R. 1971. The effect of phage T4 infection on phospholipid hydrolysis in *Escherichia coli*. *Virology* **44**:94-100.
175. Kaback, H. R. 1974. Transport in isolated bacterial membrane vesicles. *Methods Enzymol.* **31**:698-709.
176. Kadosh, D., L. Matthews, and J. W. Roberts. Unpublished data.
177. Kao, S.-H., and W. H. McClain. 1980. Baseplate protein of bacteriophage T4 with both structural and lytic functions. *J. Virol.* **34**:95-103.
178. Kao, S.-H., and W. H. McClain. 1980. Roles of bacteriophage T4 gene 5 and gene s products in cell lysis. *J. Virol.* **34**:104-107.
179. Karnik, S., and M. Billeter. 1983. The lysis function of RNA bacteriophage Q β is mediated by the maturation (A₂) protein. *EMBO J.* **2**:1521-1526.
180. Kastelein, R. A., E. Remaut, W. Fiers, and J. van Duin. 1982. Lysis gene expression of RNA phage MS2 depends on a frameshift during translation of the overlapping coat protein gene. *Nature (London)* **295**:35-41.
181. Keck, W., and U. Schwarz. 1979. *Escherichia coli* murein-DD-endopeptidase insensitive to beta-lactam antibiotics. *J. Bacteriol.* **139**:770-774.
182. Korat, B., and W. Keck. 1988. Expression of *dacB*, the structural gene of penicillin-binding protein 4, in *Escherichia coli*, p. 306-311. In P. Actor, L. Daneo-Moore, M. L. Higgins, M. R. J. Salton, and G. D. Shockman (ed.), *Antibiotic inhibition of bacterial cell surface assembly and function*. American Society for Microbiology, Washington, D.C.
183. Krebs, M. P., and W. S. Reznikoff. 1986. Transcriptional and translational initiation sites of IS50: control of transposase and inhibitor expression. *J. Mol. Biol.* **192**:781-791.
184. Krylov, V. N. 1971. Star mutants of the bacteriophage T4B. *Genetika* **7**:112-119.
185. Krylov, V. N., and T. G. Plotnikova. 1972. Genetic and physiological study of amber mutants in gene *stIII* of T4B phage. *Genetika* **8**:85-95.
186. Krylov, V. N., and N. K. Yankovsky. 1975. Mutations of the new gene *stIII* of bacteriophage T4B suppressing the lysis defect of gene *stIII* and a gene *e* mutant. *J. Virol.* **15**:22-26.
187. Kusser, W., and E. E. Ishiguro. 1987. Suppression of mutations conferring penicillin tolerance by interference with the stringent control mechanism of *Escherichia coli*. *J. Bacteriol.* **169**:4396-4398.
188. Lerner, T. J., and N. D. Zinder. 1977. Discontinuous release of phage f2. *Virology* **79**:236-238.
189. Lewin, B. 1977. Gene expression III: plasmids and phages, p. 723. John Wiley & Sons, Inc., New York.
190. Lindahl, G. 1974. Characterization of conditional lethal mutants of bacteriophage P2. *Mol. Gen. Genet.* **128**:249-260.
191. Linder, C. H., and K. Carlson. 1985. *Escherichia coli* Rho factor is involved in lysis of bacteriophage T4-infected cells. *Genetics* **111**:197-218.
192. Lubitz, W., R. E. Harkness, and E. E. Ishiguro. 1984. Requirement for a functional host cell autolytic enzyme system for lysis of *Escherichia coli* by bacteriophage ϕ X174. *J. Bacteriol.* **159**:385-387.
193. Lubitz, W., and R. Plapp. 1980. Murein degradation in *Escherichia coli* infected with bacteriophage ϕ X174. *Curr. Microbiol.* **4**:301-304.
194. Lubitz, W., and R. Plapp. 1983. Stimulation of autolysis by adsorption of bacteriophage ϕ X174 to isolated cell walls. *Curr. Microbiol.* **8**:63-65.
195. Lubitz, W., R. Schmid, and R. Plapp. 1981. Alterations in the cytoplasmic and outer membranes of *Escherichia coli* infected with bacteriophage ϕ X174. *Curr. Microbiol.* **5**:45-50.
196. Luk, K.-C., and W. Szybalski. 1983. Tandem transcription-termination sites in the late rightward operon of bacteriophage lambda. *Mol. Gen. Genet.* **189**:289-297.
197. Lwoff, A. 1966. The prophage and I, p. 93. In J. Cairns, G. S. Stent, and J. D. Watson (ed.), *Phage and the origins of molecular biology*. Cold Spring Harbor Laboratory, Cold Spring Harbor, N.Y.
198. Manoil, C., J. J. Mekalanos, and J. Beckwith. 1990. Alkaline phosphatase fusions: sensors of subcellular location. *J. Bacteriol.* **172**:515-518.
199. Manoil, C., N. Sinha, and B. Alberts. 1977. Intracellular DNA-protein complexes from bacteriophage T4-infected cells isolated by a rapid two step procedure. *J. Biol. Chem.* **252**:2734-2741.
200. Maratea, D., K. Young, and R. Young. 1985. Deletion and fusion analysis of the ϕ X174 lysis gene *E*. *Gene* **40**:39-46.
201. Markert, A., and W. Zillig. 1965. Studies on the lysis of *Escherichia coli* C by bacteriophage ϕ X174. *Virology* **25**:88-97.
202. Matsushashi, M., J. N. Maruyama, Y. Takagaki, S. Tamaki, Y. Nishimura, and Y. Hirota. 1978. Isolation of a mutant of *E. coli* lacking penicillin-sensitive D-alanyl carboxypeptidase Ia. *Proc. Natl. Acad. Sci. USA* **75**:2631-2635.
203. Matthews, C. K., E. M. Kutter, M. Mosig, and P. B. Berget (ed.). 1983. *Bacteriophage T4*. American Society for Microbiology, Washington, D.C.
204. Matz, K., M. Schmandt, and G. N. Gussin. 1982. The *rex* gene of bacteriophage lambda is really two genes. *Genetics* **102**:319-327.
205. McCommas, S. A., and M. Syvanen. 1988. Temporal control of transposition in Tn5. *J. Bacteriol.* **170**:889-894.
206. McFall, E., and G. S. Stent. 1958. Three star mutants of coliphage T2. *J. Gen. Microbiol.* **18**:346-363.
207. McPheeters, D. S., A. Christensen, E. T. Young, G. Stormo, and L. Gold. 1986. Translational regulation of expression of the bacteriophage T4 lysozyme gene. *Nucleic Acids Res.* **14**:5813-5826.
208. Meyer, E. O. Personal communication.
209. Miller, F. D., R. J. Winkfein, J. B. Rattner, and J. H. van de Sande. 1984. Sequence analysis of a PM2-DNA anti-Z-IgG-binding region. *Biosci. Rep.* **4**:885-895.
210. Mindich, L. Personal communication.
211. Mindich, L. 1978. Bacteriophages that contain lipid, p. 271-335. In R. R. Wagner (ed.), *Comprehensive virology*. Plenum Publishing Corp., New York.
212. Mindich, L., D. Bamford, C. Goldthwaite, M. Laverly, and G. Mackenzie. 1982. Isolation of nonsense mutants of lipid-containing bacteriophage PRD1. *J. Virol.* **44**:1013-1020.
213. Mindich, L., and J. Lehman. 1979. Cell wall lysis as a component of the bacteriophage ϕ 6 virion. *J. Virol.* **30**:489-496.
214. Miyazaki, J.-I., Y. Ryo, H. Fujisawa, and T. Minagawa. 1978. Mutation in bacteriophage T3 affecting host cell lysis. *Virology* **89**:327-329.
215. Model, P., R. E. Webster, and N. D. Zinder. 1979. Character-

- ization of Op3, a lysis-defective mutant of bacteriophage f2. *Cell* **18**:235–244.
216. **Model, P. G., P. Model, and N. D. Zindler.** 1979. Ultrastructure of Op3-infected *E. coli*. *Cell* **18**:244–246.
 217. **Moffatt, B. A., and F. W. Studier.** 1987. T7 lysozyme inhibits transcription by T7 RNA polymerase. *Cell* **49**:221–227.
 218. **Mohana-Rao, J. K., and P. Argos.** 1986. A conformational preference parameter to predict helices in integral membrane proteins. *Biochim. Biophys. Acta* **869**:197–214.
 219. **Molineux, I.** Personal communication.
 220. **Montag, D., M. Degen, and U. Henning.** 1987. Nucleotide sequence of gene *t* (lysis gene) of the *E. coli* phage T4. *Nucleic Acids Res.* **15**:6736.
 221. **Moreillon, P., Z. Markiewicz, S. Nachman, and A. Tomasz.** 1990. Two bacteriocidal targets for penicillin in pneumococci: autolysis-dependent and autolysis-independent killing mechanisms. *Antimicrob. Agents Chemother.* **34**:33–39.
 222. **Moreillon, P., and A. Tomasz.** 1988. Penicillin resistance and defective lysis in clinical isolates of pneumococci: evidence for two kinds of antibiotic pressure operating in the clinical environment. *J. Infect. Dis.* **157**:1150–1157.
 223. **Morham, S.** 1985. M.S. thesis. Texas A&M University, College Station.
 224. **Mosig, G., G. W. Lin, J. Franklin, and W.-H. Fan.** 1989. Functional relationships and structural determinants of two bacteriophage T4 lysozymes: a soluble (gene *e*) and a base-plate-associated (gene 5) protein. *New Biol.* **1**:171–179.
 225. **Mukai, F., G. Streisinger, and B. Miller.** 1967. The mechanisms of lysis in phage T4-infected cells. *Virology* **33**:398–404.
 226. **Mukherjee, P. K., and R. K. Mandal.** 1976. Role of *S* gene of bacteriophage lambda in host lysis. *Biochem. Biophys. Res. Commun.* **70**:302–309.
 227. **Nagai, K., and H. C. Thogersen.** 1987. Synthesis and sequence-specific proteolysis of hybrid proteins produced in *Escherichia coli*. *Methods Enzymol.* **153**:461–481.
 228. **Nam, K.** 1991. Ph.D. thesis. Texas A&M University, College Station.
 229. **Nam, K., U. Bläsi, M. T. Zagotta, and R. Young.** 1989. Conservation of a dual-start motif in P22 lysis gene regulation. *J. Bacteriol.* **172**:204–211.
 230. **Obringer, J., P. McCreary, and H. Bernstein.** 1988. Bacteriophage T4 genes *sp* and 40 apparently are the same. *J. Virol.* **62**:3043–3045.
 231. **Ono, T., and Y. Ohnishi.** 1981. Degradation of ribosomal RNA in bacteriophage lambda lysogens after thermal induction. *Microbiol. Immunol.* **25**:433–444.
 232. **Ozaki, K., and R. C. Valentine.** 1973. Inhibition of bacterial cell wall mucopeptide synthesis: a new function of RNA bacteriophage Q β . *Biochim. Biophys. Acta* **304**:707–714.
 233. **Pačes, V., C. Vlček, P. Urbanek, and Z. Hostomsky.** 1986. Nucleotide sequence of the right early region of *Bacillus subtilis* phage PZA completes the 19366-bp sequence of PZA genome. Comparison with the homologous sequence of phage ϕ 29. *Gene* **44**:115–120.
 234. **Pakula, T. M., H. Savilahti, and D. H. Bamford.** 1989. Comparison of the amino acid sequence of the lytic enzyme from broad-host-range bacteriophage PRD1 with sequences of other cell-wall-peptidoglycan lytic enzymes. *Eur. J. Biochem.* **180**:149–152.
 235. **Park, J. T.** 1987. The murein sacculus, p. 23–30. In F. C. Neidhardt, J. L. Ingraham, K. B. Low, B. Magasanik, M. Schaechter, and H. E. Umbarger (ed.), *Escherichia coli* and *Salmonella typhimurium*: cellular and molecular biology. American Society for Microbiology, Washington, D.C.
 236. **Peterson, R. F., K. D. Kievit, and H. L. Ennis.** 1972. Membrane protein synthesis after infection of *Escherichia coli* B with phage T4: the rIIB protein. *Virology* **50**:520–527.
 237. **Pollock, T. J., E. S. Tessman, and I. Tessman.** 1978. Identification of lysis protein E of bacteriophage ϕ X174. *J. Virol.* **28**:408–410.
 238. **Poteete, A.** Personal communication.
 239. **Poteete, A. R., D. Rennell, and S. E. Bouvier.** 1992. Functional significance in conserved amino acid residues. *Proteins Struct. Funct. Genet.* **13**:38–40.
 240. **Powell, J. K., and K. D. Young.** 1991. Lysis of *Escherichia coli* by β -lactams which bind penicillin-binding proteins 1a and 1b: inhibition by heat shock proteins. *J. Bacteriol.* **173**:4021–4026.
 241. **Pribnow, D., D. C. Sigurdson, L. Gold, B. S. Singer, C. Napoli, J. Brosius, T. J. Dull, and H. F. Noller.** 1981. *rII* cistrons of bacteriophage T4: DNA sequence around the intercistronic divide and positions of genetic landmarks. *J. Mol. Biol.* **149**:337–376.
 242. **Raab, R.** 1988. Ph.D. thesis. Texas A&M University, College Station.
 243. **Raab, R., G. Neal, J. Garrett, R. Grimaila, R. Fusselman, and R. Young.** 1986. Mutational analysis of bacteriophage lambda lysis gene *S*. *J. Bacteriol.* **167**:1035–1042.
 244. **Raab, R., G. Neal, C. Sohaskey, J. Smith, and R. Young.** 1988. Dominance in lambda *S* mutations and evidence for translational control. *J. Mol. Biol.* **199**:95–105.
 245. **Raab, R., and R. Young.** Unpublished data.
 246. **Rae, M. E., and M. Stodolsky.** 1974. Chromosome breakage, fusion and reconstruction during P1d1 transduction. *Virology* **58**:32–54.
 247. **Ray, P. N., and M. L. Pearson.** 1974. Evidence for post-transcriptional control of the morphogenetic genes of bacteriophage lambda. *J. Mol. Biol.* **85**:163–175.
 248. **Reader, R. W., and L. Siminovitch.** 1971. Lysis defective mutants of bacteriophage lambda: on the role of the *S* function in lysis. *Virology* **43**:623–637.
 249. **Redfield, R. J., and A. M. Campbell.** 1987. Structure of cryptic lambda prophages. *J. Mol. Biol.* **198**:393–404.
 250. **Rennell, D., and A. R. Poteete.** 1985. Phage P22 lysis genes: nucleotide sequences and functional relationships with T4 and lambda genes. *Virology* **143**:280–289.
 251. **Riede, I.** 1987. Lysis gene *t* of T-even bacteriophages: evidence that colicins and bacteriophage genes have common ancestors. *J. Bacteriol.* **169**:2956–2961.
 252. **Roberts, J. W.** 1975. Transcription termination and late control in phage lambda. *Proc. Natl. Acad. Sci. USA* **72**:3300–3304.
 253. **Rolfe, B. G., and J. H. Campbell.** 1974. A relationship between tolerance to colicin K and the mechanism of phage-induced host cell lysis. *Mol. Gen. Genet.* **133**:293–297.
 254. **Rolfe, B. G., and J. H. Campbell.** 1977. Genetic and physiological control of host cell lysis by bacteriophage lambda. *J. Virol.* **23**:626–636.
 255. **Romantschuk, M., V. M. Olkkonen, and D. H. Bamford.** 1988. The nucleocapsid of bacteriophage ϕ 6 penetrates the host cytoplasmic membrane. *EMBO J.* **7**:1821–1829.
 256. **Romero, A., R. Lopez, and P. Garcia.** 1990. Characterization of the pneumococcal bacteriophage HB-3 amidase: cloning and expression in *Escherichia coli*. *J. Virol.* **64**:137–142.
 257. **Ronda-Lain, C., R. Lopez, A. Tapia, and A. Tomasz.** 1977. Role of the pneumococcal autolysin (murein hydrolase) in the release of progeny bacteriophage and in the bacteriophage-induced lysis of the host cells. *J. Virol.* **21**:366–374.
 258. **Roof, W., and R. Young.** Unpublished data.
 259. **Rutberg, B., and L. Rutberg.** 1965. Role of superinfecting phage in lysis inhibition with phage T4 in *Escherichia coli*. *J. Bacteriol.* **90**:891–894.
 260. **Sadowski, P. D., and C. Kerr.** 1970. Degradation of *Escherichia coli* B deoxyribonucleic acid after infection with deoxyribonucleic acid-defective amber mutants of bacteriophage T7. *J. Virol.* **6**:149–155.
 261. **Sampson, L. L., R. W. Hendrix, W. M. Huang, and S. R. Casjens.** 1988. Translation initiation controls the relative rates of expression of the bacteriophage lambda late genes. *Proc. Natl. Acad. Sci. USA* **85**:5439–5443.
 262. **Sanchez-Puelles, J. M., C. Ronda, E. Garcia, E. Mendez, J. L. Garcia, and R. Lopez.** 1986. A new peptidoglycan hydrolase in *Streptococcus pneumoniae*. *FEMS Microbiol. Lett.* **35**:163–166.
 263. **Sanger, F., A. R. Coulson, T. Friedmann, G. M. Air, B. G. Barrell, N. L. Brown, J. C. Fiddes, C. A. Hutchison III, P. M. Slocombe, and M. Smith.** 1978. The nucleotide sequence of bacteriophage ϕ X174. *J. Mol. Biol.* **125**:225–246.

264. Sauer, B., R. Calendar, E. Ljungquist, E. Six, and M. G. Sunshine. 1982. Interaction of satellite phage P4 with phage 186 helper. *Virology* **116**:523-534.
265. Schmidt, B. F., B. Berkhout, G. P. Overbeek, A. van Strien, and J. van Duin. 1987. Determination of the RNA secondary structure that regulates lysis gene expression in bacteriophage MS2. *J. Mol. Biol.* **195**:505-516.
266. Scholtissek, S., and F. Grosse. 1988. A plasmid vector system for the expression of a triprotein consisting of β -galactosidase, a collagenase recognition site and a foreign gene product. *Gene* **62**:55-64.
267. Schüller, A., R. E. Harkness, U. Rütter, and W. Lubitz. 1985. Deletion of C-terminal amino acid codons of ϕ X174 gene E: effect on its lysis inducing properties. *Nucleic Acids Res.* **13**:4143-4153.
268. Shearman, C., H. Underwood, K. Jury, and M. Gasson. 1989. Cloning and DNA sequence analysis of a *Lactococcus* bacteriophage lysis gene. *Mol. Gen. Genet.* **218**:214-221.
269. Shinedling, S., D. Parma, and L. Gold. 1987. Wild-type bacteriophage T4 is restricted by the lambda *rex* genes. *J. Virol.* **61**:3790-3794.
270. Shinedling, S., B. S. Singer, M. Gayle, D. Pribnow, E. Jarvis, B. Edgar, and L. Gold. 1987. Sequences and studies of bacteriophage T4 RII mutants. *J. Mol. Biol.* **195**:471-480.
271. Silberstein, S., M. Inouye, and F. W. Studier. 1975. Studies on the role of bacteriophage T7 lysozyme during phage infection. *J. Mol. Biol.* **96**:1-11.
272. Silhavy, T. J., P. J. Bassford, Jr., and J. R. Beckwith. 1979. A genetic approach to the study of protein localization in *Escherichia coli*, p. 203-254. *In* M. Inouye (ed.), *Bacterial outer membranes*. John Wiley & Sons, Inc., New York.
273. Singer, B. S., S. T. Shinedling, and L. Gold. 1983. Some complexities of T4 genes, gene products, and gene product interactions, p. 327-333. *In* C. K. Matthews, E. M. Kutter, G. Mosig, and P. B. Berget (ed.), *Bacteriophage T4*. American Society for Microbiology, Washington, D.C.
274. Sinsheimer, R. L. 1968. Bacteriophage ϕ X174 and related viruses. *Prog. Nucleic Acid Res. Mol. Biol.* **8**:115-169.
275. Six, E. W. 1975. The helper dependence of satellite bacteriophage P4: which gene functions of bacteriophage P2 are needed by P4? *Virology* **67**:249-263.
276. Sklar, J., P. Yot, and S. M. Weissmann. 1975. Determination of genes, restriction sites, and DNA sequences surrounding the 6S RNA template of bacteriophage lambda. *Proc. Natl. Acad. Sci. USA* **72**:1817-1821.
277. Sklar, J. L. 1977. Ph.D. thesis. Yale University, New Haven, Conn.
278. Snyder, L., and K. McWilliams. 1989. The *rex* genes of bacteriophage lambda can inhibit cell function without phage superinfection. *Gene* **81**:17-24.
279. Sohaskey, C. 1992. M.S. thesis. Texas A&M University, College Station.
280. Sohaskey, C., R. Johnson-Boaz, and R. Young. Unpublished data.
281. Stent, G. S., and O. Maaloe. 1953. Radioactive phosphorus tracer studies on the reproduction of T4 bacteriophage. *Biochim. Biophys. Acta* **10**:55-69.
- 281a. Stewart, C. 1988. Bacteriophage SPOI, p. 507. *In* R. Calendar (ed.), *The bacteriophages*. Plenum Press, New York.
282. Streisinger, G., F. Mukai, W. J. Dreyer, B. Miller, and S. Horiuchi. 1961. Mutations affecting the lysozyme of phage T4. *Cold Spring Harbor Symp. Quant. Biol.* **26**:25-30.
283. Studier, F. W. 1972. Bacteriophage T7. Genetic and biochemical analysis of this simple phage gives information about basic genetic processes. *Science* **176**:367-376.
284. Studier, F. W., and X. Zhang. Personal communication.
285. Symonds, N. 1958. The properties of a star mutant of phage T2. *J. Gen. Microbiol.* **18**:330-345.
286. Syvanen, M. Personal communication.
287. Taylor, A. 1971. Endopeptidase activity of phage lambda-endolysin. *Nature (London) New Biol.* **234**:144-145.
288. Tomasz, A. 1967. Choline in the cell wall of a bacterium: novel type of polymer-linked choline in *Pneumococcus*. *Science* **157**:694-697.
289. Tomioka, S., and M. Matsushashi. 1978. Purification of penicillin-insensitive DD-endopeptidase, a new cell wall peptidoglycan-hydrolyzing enzyme in *Escherichia coli*, and its inhibition by deoxyribonucleic acids. *Biochem. Biophys. Res. Commun.* **84**:978-984.
290. Tosi, M., B. E. Reilly, and D. L. Anderson. 1975. Morphogenesis of bacteriophage ϕ 29 of *Bacillus subtilis*: cleavage and assembly of the neck appendage protein. *J. Virol.* **16**:1282-1295.
291. Tsugita, A., and M. Inouye. 1968. Complete primary structure of phage lysozyme from *Escherichia coli* T4. *J. Mol. Biol.* **37**:201-212.
292. Tsukagoshi, N., R. Schäfer, and R. M. Franklin. 1977. Structure and synthesis of a lipid-containing bacteriophage. An endolysin activity associated with bacteriophage PM2. *Eur. J. Biochem.* **77**:585-588.
293. van Duin, J. Personal communication.
294. van Duin, J. 1988. Single-stranded RNA bacteriophages, p. 117-167. *In* R. Calendar (ed.), *The bacteriophages*. Plenum Press, New York.
295. Visconti, N. 1953. Resistance to lysis from without in bacteria infected with T2 bacteriophage. *J. Bacteriol.* **66**:247-253.
296. Vlček, C., and V. Pačes. 1986. Nucleotide sequence of the late region of Bacillus phage ϕ 29 completes the 19285-bp sequence of ϕ 29 genome. Comparison with the homologous sequence of phage PZA. *Gene* **46**:215-225.
297. von Heijne, G., and C. Manoil. 1990. Membrane proteins: from sequence to structure. *Protein Eng.* **4**:109-112.
298. Wadle, D., B. Henrich, and R. Plapp. 1986. Effect of mutations in genes *fadR*, *fabB*, *fadE* and *envC* of *Escherichia coli* on the action of the lysis gene of bacteriophage ϕ X174. *Curr. Microbiol.* **14**:65-69.
299. Walderich, B., and J.-V. Höltje. 1989. Specific localization of the lysis protein of bacteriophage MS2 in membrane adhesion sites of *Escherichia coli*. *J. Bacteriol.* **171**:3331-3336.
300. Walderich, B., A. Ursinus-Wössner, J. van Duin, and J.-V. Höltje. 1988. Induction of the autolytic system of *Escherichia coli* by specific insertion of bacteriophage MS2 lysis protein into the bacterial cell envelope. *J. Bacteriol.* **170**:5027-5033.
301. Walker, J. T., and D. H. Walker, Jr. 1980. Mutations in coliphage P1 affecting host cell lysis. *J. Virol.* **35**:519-530.
302. Watson, J. D. 1950. The properties of x-ray inactivated bacteriophage. I. Inactivation by direct effect. *J. Bacteriol.* **60**:697-718.
303. Watson, J. D., N. H. Hopkins, J. W. Roberts, J. A. Steitz, and A. M. Weiner. 1987. Molecular biology of the gene, p. 507. The Benjamin/Cummings Publishing Co., Inc., Menlo Park, Calif.
304. Weaver, L. H., D. Rennell, A. R. Poteete, and B. W. Mathews. 1985. Structure of phage P22 gene 19 lysozyme inferred from its homology with phage T4 lysozyme. Implications of lysozyme evolution. *J. Mol. Biol.* **184**:739-741.
305. Weber, K., and W. Konigsberg. 1975. Proteins of the RNA phages, p. 51. *In* N. D. Zinder (ed.), *RNA phages*. Cold Spring Harbor Laboratory, Cold Spring Harbor, N.Y.
306. Weintraub, S. B., and F. R. Frankel. 1972. Identification of the T4rIIB gene product as a membrane protein. *J. Mol. Biol.* **70**:589-615.
307. Wilson, D. B. 1982. Effect of the lambda S gene product on properties of the *E. coli* inner membrane. *J. Bacteriol.* **151**:1403-1410.
308. Wilson, D. B., and A. Okabe. 1982. A second function of the S gene of bacteriophage lambda. *J. Bacteriol.* **152**:1091-1095.
309. Winter, R. B., and L. Gold. 1983. Overproduction of bacteriophage Q β maturation (A₂) protein leads to cell lysis. *Cell* **33**:877-885.
310. Witte, A., U. Bläsi, G. Halfmann, M. Szostak, G. Wanner, and W. Lubitz. 1990. ϕ X174 protein E-mediated lysis of *Escherichia coli*. *Biochimie* **72**:191-200.
311. Witte, A., and W. Lubitz. 1989. Biochemical characterization of ϕ X174-protein-E-mediated lysis of *Escherichia coli*. *Eur. J. Biochem.* **180**:393-398.
312. Witte, A., W. Lubitz, and E. P. Bakker. 1987. Proton-motive-force-dependent step in the pathway to lysis of *Escherichia coli*

- induced by bacteriophage ϕ X174 gene *E* product. *J. Bacteriol.* **169**:1750–1752.
313. **Witte, A., G. Wanner, U. Bläsi, G. Halfmann, M. Szostak, and W. Lubitz.** 1990. Endogenous transmembrane tunnel formation mediated by ϕ X174 lysis protein *E*. *J. Bacteriol.* **172**:4109–4114.
314. **Yamada, M., H. Fujisawa, H. Kato, K. Hamada, and T. Minagawa.** 1986. Cloning and sequencing of the genetic right end of bacteriophage T3 DNA. *Virology* **151**:350–361.
316. **Yamazaki, Y.** 1969. Enzymatic activities on cell walls in bacteriophage T4. *Biochim. Biophys. Acta* **178**:542–559.
317. **Yarmolinsky, M. B., and N. Sternberg.** 1988. Bacteriophage P1, p. 291–438. *In* R. Calendar (ed.), *The bacteriophages*. Plenum Press, New York.
318. **Young, K., R. J. Anderson, and R. J. Hafner.** 1989. Lysis of *Escherichia coli* by the bacteriophage ϕ X174 *E* protein: inhibition of lysis by heat shock proteins. *J. Bacteriol.* **171**:4334–4341.
319. **Young, K., and R. Young.** 1982. Lytic action of cloned ϕ X174 gene *E*. *J. Virol.* **44**:993–1002.
320. **Young, K. D.** Personal communication.
321. **Young, K. D., and R. F. Young.** Unpublished data.
322. **Young, R.** Unpublished data.
323. **Young, R., J. Way, S. Yin, and M. Syvanen.** 1979. Transposition mutagenesis of bacteriophage lambda: a new gene affecting cell lysis. *J. Mol. Biol.* **132**:307–322.
324. **Zagotta, M. T., and D. B. Wilson.** 1990. Oligomerization of the bacteriophage lambda *S* protein in the inner membrane of *E. coli*. *J. Bacteriol.* **172**:912–921.
325. **Zinder, N. D., and L. B. Lyons.** 1968. Cell lysis: another function of the coat protein of the bacteriophage f2. *Science* **159**:84–86.