

Hydrodynamic Focusing and Electronic Cell-Sizing Techniques

M. L. SHULER, R. ARIS, AND H. M. TSUCHIYA

Department of Microbiology, Department of Chemical Engineering and Materials Science, University of Minnesota, Minneapolis, Minnesota 55455

Received for publication 24 May 1972

The technique of hydrodynamic focusing, used to improve the resolution of the Coulter counter for the sizing of bacteria, was examined. Latex particles of $0.26 \mu\text{m}^3$ to $6.7 \mu\text{m}^3$ volume were used to examine the characteristics of the system with and without hydrodynamic focusing. The system then was evaluated for sizing mixed bacterial populations as well as single populations. Possible applications are also discussed.

One readily observable indication of the physiological state of a bacterial population is its size. For routine analysis optical or electrical resistance methods must be used to obtain size distributions. The advantages of the electrical resistance methods over optical methods have been discussed by Kubitschek (5).

The theory and operation of Coulter counters using the electrical resistance method have been detailed elsewhere (7, 10). The instrument has a small aperture with a constant current flow across it. The passage of a non-conducting particle suspended in a conducting solution through the small aperture results in a change in resistance across the aperture. This resistance change is measured as a voltage change. Kubitschek (5, 7) has shown that, for particle volumes less than one-tenth of the aperture volume, the resulting amplitude of the signal is directly proportional to the particle volume.

However, many effects, examined elsewhere (3, 7, 10, 11), can cause a large distortion in the size distribution of monosized particles obtained from the unmodified instrument. Harvey and Marr (3) have attributed the distortion largely to coincidence effects. They have suggested corrections by sampling at low counting rates or by differentiation and integration of the pulses. Kubitschek (6, 7) has made his own apertures which are much thicker than the commercially available apertures. These apertures give much improved resolution because the particle time duration within the aperture is long enough to allow the pulse of the particle to reach a plateau. Varia-

tion in particle residence time due to fluid flow patterns then has no effect on the final pulse amplitude measured. Spielman and Goren (11) used a hydrodynamic focusing unit with the unmodified Coulter counter to improve resolution. Their technique results essentially in injecting all the particles in the same streamline so that all particles have nearly the same residence time in the aperture.

The focusing technique is the simplest one to employ and does not suffer from some of the disadvantages of the other two methods. However, the focusing method does require larger sample sizes (at least five times as much) than the other methods, which makes it less suitable for use with small batch cultures.

For example, the thick aperture used by Kubitschek greatly increases coincidence effects (6). For small bacteria, coincidence of bacteria and large background particles or other bacteria might result in broadening the distribution measured. Also, the increased coincidence would make normal counting more difficult.

The electronic pulse shaping of Harvey and Marr (3) requires more elaborate equipment than our device. Also, their method makes no attempt to directly correct for flow variations across the aperture which may cause the electronic size of a particle to vary by as much as a factor of two (7). Pulse-shaping techniques probably are justified only when physical causes of distortion have been removed.

This paper reports the results of the initial application of the hydrodynamic focusing technique to the sizing of bacterial populations.

MATERIALS AND METHODS

The electrical size measurements were made with a Coulter counter model B with a 30- μ m orifice and a particle automatic size distribution plotter (25 channels for use with the model B; Coulter Electronics, Inc., Chicago, Ill.). The size data was obtained as an X-Y plot. The plotter had 25 channels, each 4 threshold units wide, and allowed variation of the counting time per channel (4 to 40 sec) and an amplitude factor.

Polystyrene latex particles of 0.796 μ m and 1.099 μ m diameter were obtained from Dow Chemical Co. (Midland, Mich.). Latex particles of 1.857 μ m were supplied by Coulter Electronics Co. (Hialeah, Fla.).

A hydrodynamic focusing unit has been previously described by Spielman and Goren (11). Our unit is a slight modification with about 18 cm of liquid head and no tube-stopper arrangement. A holder which attached to the top part of the aperture tube with a slot for the focusing unit was used. This arrangement allowed the experimenter to remove the focusing unit for sample changes and realign it reproducibly. The two 30- μ m orifices were maintained about 2 mm apart. A sketch of the device is given in Fig. 1.

All samples were prepared in "saline" (0.6% NaCl and 0.02% disodium ethylenediaminetetraacetic acid [Na_2EDTA]) filtered through a 0.22- μ m membrane filter (Millipore Corp.). When the focusing unit was employed, a saline-filtered media mixture equivalent to the mixture inside the focusing unit was used to eliminate conductivity variations.

Bacteria used were *Escherichia coli* B/r and *Azotobacter vinelandii* O.P. Minimal salts media, "C"

medium, ($[\text{NH}_4]_2\text{SO}_4$, 1.25 g; KH_2PO_4 , 1.50 g; $\text{MgSO}_4 \cdot 7\text{H}_2\text{O}$, 0.10 g; NaCl, 0.010 g; K_2HPO_4 , 3.00 g; $\text{FeSO}_4 \cdot 7\text{H}_2\text{O}$, 0.001 g; $\text{Na}_2\text{EDTA} \cdot 2\text{H}_2\text{O}$ to 10^{-6} M; glucose, 0.50 g; pH 7.0 ± 0.5 , all in 1,000 ml of distilled water) for *E. coli* and Burk's medium (KH_2PO_4 , 0.41 g; Na_2SO_4 , 0.15 g; CaCl_2 , 0.02 g; $\text{MgSO}_4 \cdot 7\text{H}_2\text{O}$, 0.10 g; $\text{FeSO}_4 \cdot 7\text{H}_2\text{O}$, 0.005 g; $\text{NaMoO}_4 \cdot 2\text{H}_2\text{O}$, 0.00025 g; K_2HPO_4 , 0.52 g; 7.0 ± 0.5 , all in 1,000 ml of distilled water) for *Azotobacter vinelandii* were used. Glucose in different concentrations was used as the carbon source in the Burk's medium. Media were filtered through 1.2- μ m membrane filters (Millipore Corp.).

In a typical run, the bacterial sample was diluted in saline (dilution dependent on cell concentration and the width of size distribution) and placed in the focus tube prerinsed with clean saline. The 30- μ m orifices were visually centered on each other. Constant pressure was maintained by leaving the stopcock open or pulling the mercury into the bulb below the counting section and closing the stopcock.

Background runs were made and background levels were subtracted from the experimental ones. When a major peak was in channel 2, a determination was made with the addition of larger latex particles to insure that none of the cells were appearing in channel 1 which normally had very high background counts. The particles were mixed at a known sample-latex ratio. The mixture was sized and peak area ratios were compared to the sample-latex ratio. Sample loss, if any, could be determined in this manner.

The data was obtained as a histogram and was analyzed for the mean channel position and the width at one-half peak height. The mean channel location (i.e., relative pulse height) was calculated from the following formula

$$\bar{x} = (1/n_T) \sum_{i=M}^N x_i n_i \quad (1)$$

where \bar{x} = mean channel number, n_T = total of peak heights, x_i = channel number i , n_i = peak height registered at channel i , M = first channel registering a peak, and N = last channel registering a peak.

RESULTS

Since the data is obtained as a histogram, some caution is required in the interpretation of the results as presented in the graphs. The graphs in this section are drawn so that the bar height is represented as a single point centered at the appropriate channel number. This was done to allow a clearer representation of several size distributions on the same graph. Also, due to the finite width of each channel a curve drawn under the above conventions would have a width at half peak height of one channel unit (4 threshold units) for a nondis-

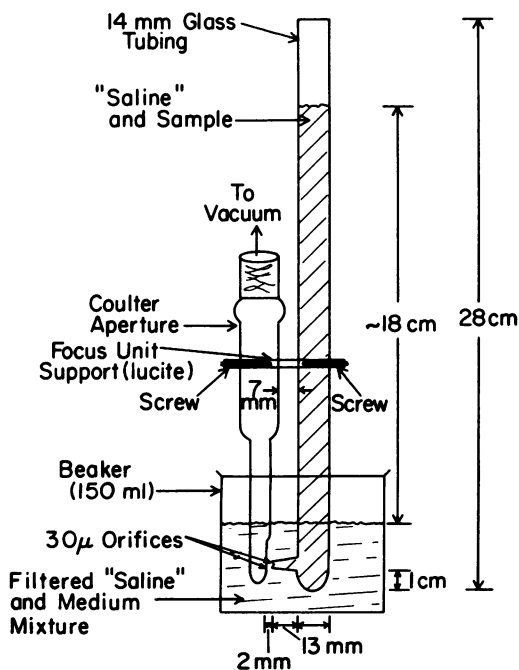

FIG. 1. Focusing unit during operation.

torted distribution of a monosized particle.

Figure 2 shows the effect of hydrodynamic focusing on the size distributions obtained from 1.099- μm latex particles. The width at one-half peak height was 1.7 times greater for the unfocused distribution. Similar results were obtained for 0.796- and 1.856- μm particles. Also note should be made of the time independence of the focus distribution. The mean peak position is reproducible within 1% if the same aperture tube is used.

Figure 3 shows the effect of concentration within the focusing unit on the final size distribution. Concentrations from 2.3×10^6 to 8.8×10^6 particles/ml gave almost identical curves. Decreases in concentration from the above level caused a broadening of peak width and a slight increase in the mean channel number locating the peak. At 1.2×10^5 particles/ml the mean peak position was 4.32 rather than 4.15 for high particle concentration. Width at one-half peak height was 1.45 times greater for the 1.2×10^5 particle/ml concentration than for the higher concentrations. The small doublet tended to be smeared at lower concentrations. Due to the thinning effect of the focusing unit, the counter orifice sees a solution whose concentration is only a few percent (11) of that within the focusing

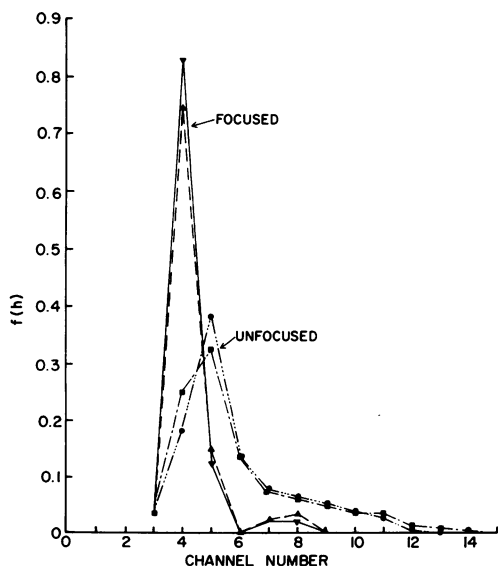

FIG. 2. Comparison of focused and nonfocused size distribution for 1.099- μm latex particles. Note time independence of focused distributions. Symbols: ∇ , focus (11/23/71); \triangle , focus (11/30/72); \blacksquare , no focus (11/23/71) with 4.5×10^6 particles/ml (p/ml); \bullet , no focus (11/23/71) with 2.0×10^6 p/ml.

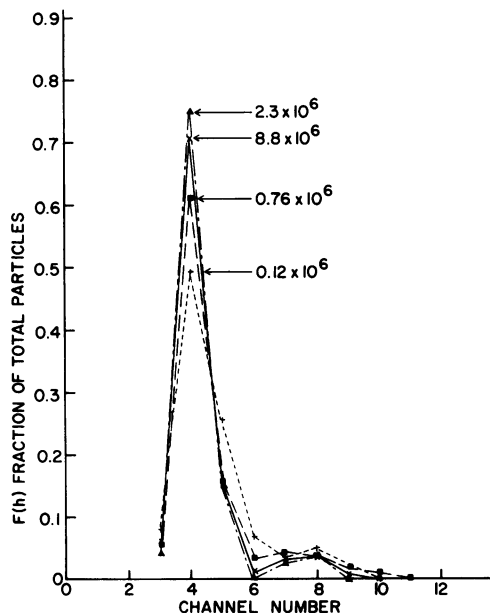

FIG. 3. Effect of particle (1.099 μm) concentration on focused size distribution. Symbols: \times , 8.8×10^6 particles/ml (p/ml); \triangle , 2.3×10^6 p/ml; \blacksquare , 0.76×10^6 p/ml; $+$, 0.12×10^6 p/ml.

unit.

Experiments with the effect of particle concentration on the unfocused condition showed no large variance for particle concentrations of 10^5 to 5×10^5 particles/ml. The lower concentrations gave somewhat poorer resolution.

A typical measurement of the size distribution of agglutinated latex particles (1.099 μm) with and without focusing is presented in Fig. 4. Note the much improved resolution obtained with the focusing unit. When working with mixtures as in Fig. 4 to obtain calibration curves, the mean peak position of particles was slightly shifted to higher channel numbers. Matthews and Rhodes (9) have also reported a similar effect for small particles in the presence of large particles. The shift was an apparent increase of volume of 2 to 6%. Calibration curves were largely constructed from the measurements of these mixtures.

A summary of calibration curves for different Coulter settings is given in Fig. 5. These curves apply only to the aperture tube for which the measurements were made. An equation has been proposed by Mercer to predict the threshold of appearance of a particle at any Coulter setting (8). A linear relation with particle volume is predicted and was found here. His data suggested that this equation might be satisfactory only for particles greater

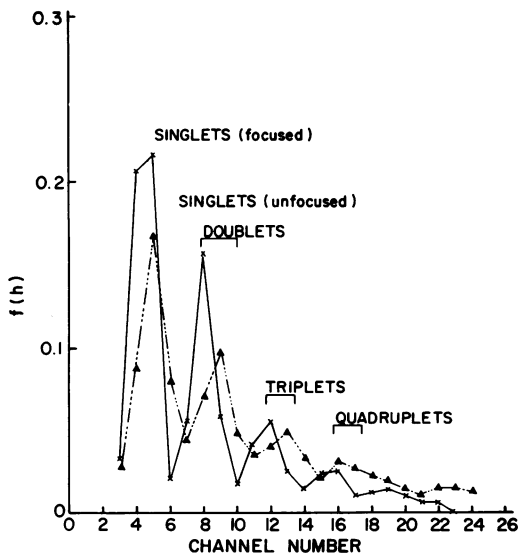

FIG. 4. Comparison of focused and unfocused size distribution for aggregated 1.099- μ m latex particles. Symbols: \times , focused; \blacktriangle , unfocused 3.7×10^5 particles/ml (p/ml); other particle concentrations (2.4×10^5 , 1.22×10^5 p/ml) gave poorer resolution in the unfocused condition.

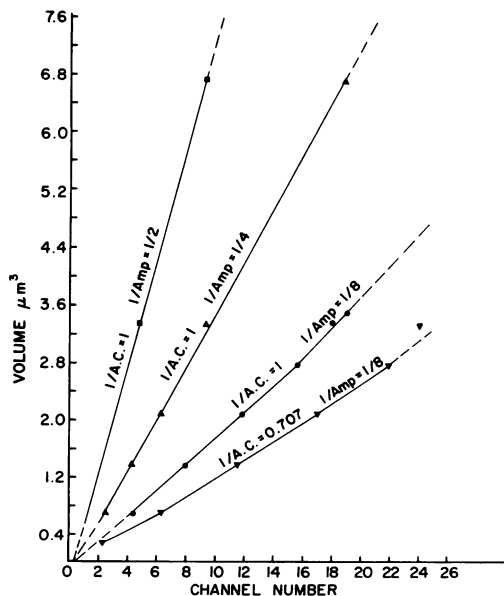

FIG. 5. Calibration of Coulter counter size distribution. Symbols: ∇ , Coulter settings, $1/\text{amplication}$ ($1/\text{amp}$) = $1/8$, $1/\text{aperture current}$ ($1/A. C.$) = 0.707 ; \bullet , $1/\text{amp}$ = $1/8$, $1/A. C.$ = 1.0 ; \blacktriangle , $1/\text{amp}$ = $1/4$, $1/A. C.$ = 1.0 ; \blacksquare , $1/\text{amp}$ = $1/2$, $1/A. C.$ = 1.0 .

than $0.75 \mu\text{m}^3$, and smaller particles would require experimental data as obtained here.

The reason the calibration lines do not pass through zero is that the fiducial point of the sizer was not matched with zero pulse amplitude from the counter.

Figure 6 shows the focused size distribution for pure *E. coli*, *A. vinelandii*, and a 40:60 mixture of *E. coli* and *A. vinelandii* and unfocused size distribution of the bacteria mixture. Note that a plot based on a 40:60 breakdown of the peak heights of the pure population yields a curve very close to the experimental curve of the bacterial mixture sized with the focusing unit. The separation in the focused case is fairly clean but not in the unfocused case.

Unfocused distributions of pure culture of bacteria have much lower resolution than the focused case. The degree of resolution of bacteria and latex particles are similar.

To obtain meaningful results with bacteria, the ionic strength of the fluid around the focusing unit and aperture should be matched to the ionic strength of the solution within the focusing unit. If this is not done, the conduc-

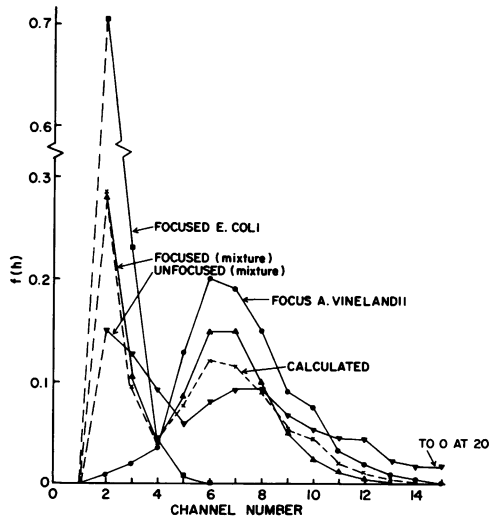

FIG. 6. Comparison of focused and unfocused size distributions of mixed bacterial populations. Symbols: \blacksquare , focused distribution of *E. coli*; \bullet , focused distribution of *A. vinelandii*; \blacktriangle , focused distribution mixture of 40% *E. coli* and 60% *A. vinelandii*; ∇ , unfocused distribution of 40/60 *E. coli*-*A. vinelandii* mixture; \times , expected points for a 40/60 mixture of *E. coli*-*A. vinelandii*. Coulter settings used were $1/A. C.$ = 0.707 $1/\text{amp}$ = $1/8$ (see legend to Fig. 5). Note experimental ratio of *E. coli* to *A. vinelandii* is $0.39/0.61$. Peaks are corrected for background.

tivity of the fluid in the streamline carrying the particles will be different from the conductivity of fluid entering the aperture from other streamlines. This conductivity difference can result in a shift of the mean peak position. For *A. vinelandii* in Burk's medium it was necessary to add filtered medium to the usual saline to match the ionic strengths.

The above experiments with both cells and latex particles indicate that the number ratio of two particles of different sizes can be obtained within about 5% by ratios of the peak areas of the particles obtained from focused size distributions.

DISCUSSION

Sizing of bacteria using the Coulter counter and hydrodynamic focusing offers speed and reasonable accuracy. The cell number and focused size distribution can be obtained within 15 to 20 min. This speed makes its use attractive for routine application. The unmodified Coulter counter system offers size resolution that is too poor to always be useful.

Our results with latex particles are similar to those obtained by Spielman and Goren (11) except the size of particles used here is smaller. In both cases a great increase in resolution was obtained.

The work with bacteria suggests two interesting possibilities. First, with focusing it is possible to quantitatively enumerate two bacterial populations when their mean sizes are somewhat different ($0.82 \mu\text{m}^3$ versus $0.25 \mu\text{m}^3$). Without focusing it would be difficult to do total cell counts for each bacteria. The second possibility is that, if cell number and mean size are known, it is possible to assign values of "total cell volume" to each bacterium. The "total cell volume" is related to cell mass and number of cells, and a correlation to dry weight for exponentially growing cells can be obtained. The above ideas might make it possible to work with some mixed populations whose closeness in size has prevented their earlier use. Also the ability to rapidly assign biomass values to each species of a population can allow the development of different types of mathematical models for the growth of mixed populations.

Many investigators have been interested in

the size distribution of bacteria for the statistical analysis of growth or the measurement of the onset of deoxyribonucleic acid synthesis. Early work was begun by Henrici (4) who optically sized bacteria and used size information in studying bacterial growth. Aiba and Endo (1) and others have used the unmodified Coulter counter to obtain the volume distribution of *A. vinelandii* in the measurement of their growth rate. The use of hydrodynamic focusing would be beneficial in this type of analysis.

The sensitivity of these experiments could be improved with a pulse analyzer with more channels. Electrical modifications as proposed by Mercer (9) and done by Harvey and Marr (3) and Edwards and Wilke (2) could result in increased resolution, although the required expenditure might make it more costly.

ACKNOWLEDGMENT

This work was supported by National Science Foundation GI-grant 28874 X1.

LITERATURE CITED

1. Aiba, S., and I. Endo. 1971. Statistical analysis of growth of microorganisms. *Amer. Inst. Chem. Eng. J.* **17**:608-612.
2. Edwards, V. H., and C. R. Wilke. 1967. Electronic sizing and counting of bacteria. *Biotechnol. Bioeng.* **11**:559-574.
3. Harvey, R. J., and A. G. Marr. 1966. Measurement of size distributions of bacterial cells. *J. Bacteriol.* **92**:805-811.
4. Henrici, A. T. 1928. Morphologic variation and the rate of growth of bacteria. Charles C. Thomas, Publisher, Springfield, Ill.
5. Kubitschek, H. E. 1958. Electronic counting and sizing of bacteria. *Nature (London)* **182**:234-235.
6. Kubitschek, H. E. 1960. Electronic measurement of particle size. *Research (London)* **13**:128-135.
7. Kubitschek, H. E. 1969. Counting and sizing microorganisms with the Coulter counter, p. 593-610. *In* R. Norris and D. W. Ribbons (ed.), *Methods in microbiology*, vol. 1. Academic Press Inc., New York.
8. Matthews, B. A., and C. T. Rhodes. 1970. Some observations on the use of the Coulter counter model B in coagulation studies. *J. Colloid Interface Sci.* **32**:339-348.
9. Mercer, W. B. 1966. Calibration of Coulter counters for particles $\sim 1 \mu$ in diameter. *Rev. Sci. Instr.* **37**:1515-1520.
10. Princen, L. H., and W. F. Kwolek. 1965. Coincidence corrections for particle size determinations with the Coulter counter. *Rev. Sci. Instr.* **36**:646-653.
11. Spielman, L., and S. L. Goren. 1968. Improving resolution in Coulter counting by hydrodynamic focusing. *J. Colloid Interface Sci.* **26**:175-182.